

Operation Description

PowerRay base station/PRABS10

1. System Block Diagram

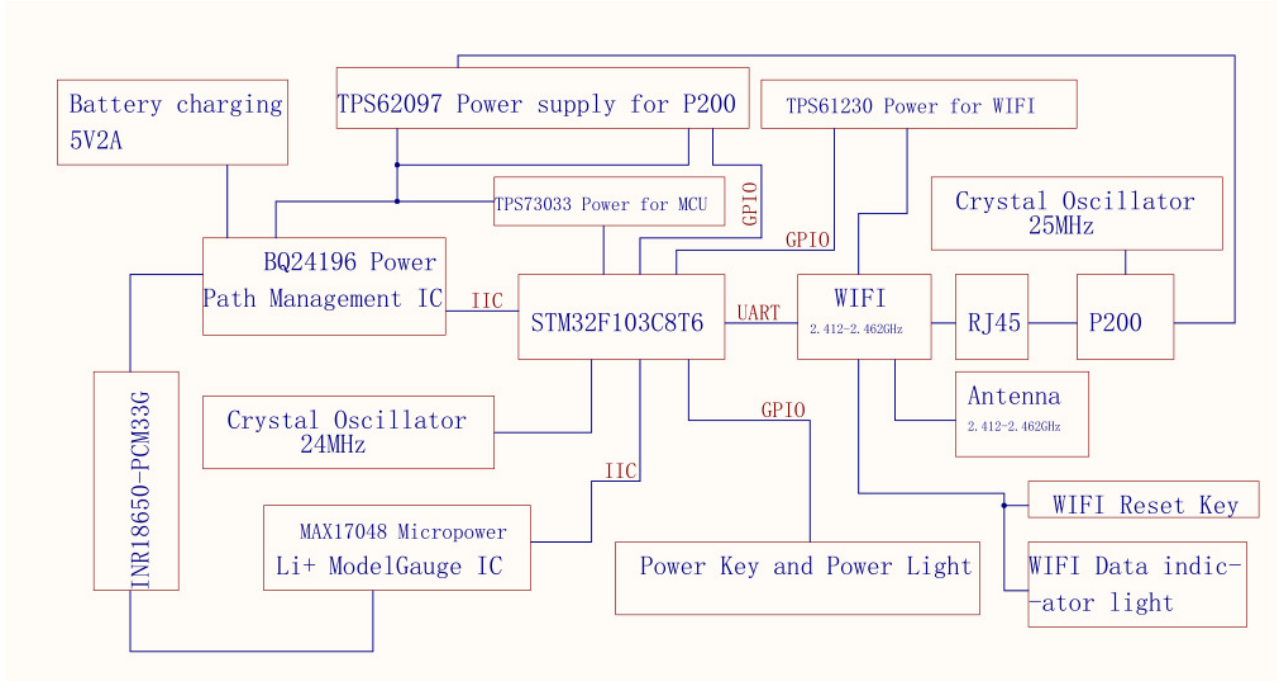

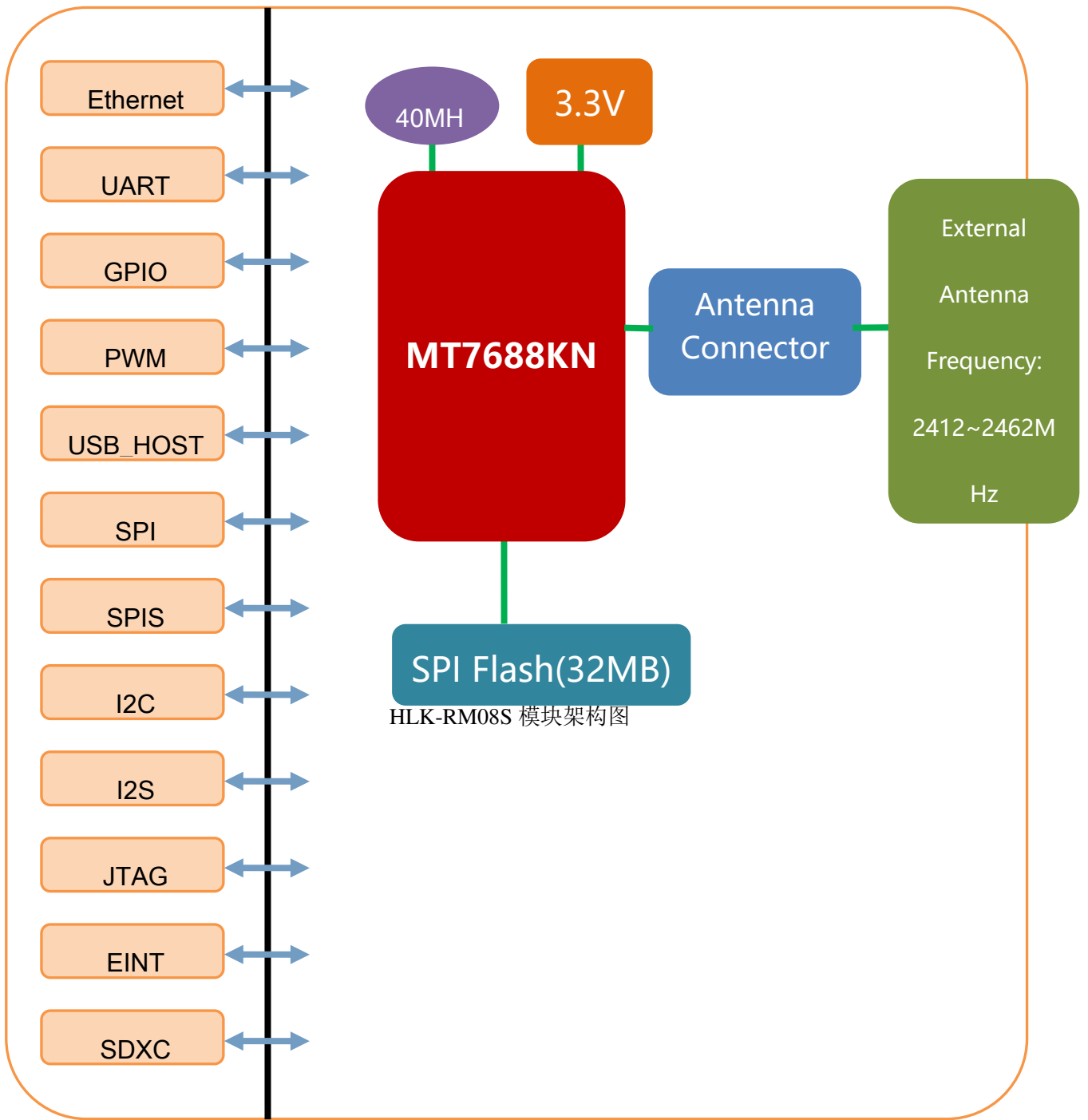

HLK-RM08S 模块架构图

2. Introduction

The MT7688KN module provides designers with a ready made component that provides a fully integrated solution for applications, using the IEEE802.11 standard in the 2.4-2.5GHz ISM frequency band, including 802.11b/g/n and also provides IEEE802.3, can be quickly and easily included in product designs. The modules integrate all of the RF components required, removing the need to perform expensive RF design and test. Products can be designed by simply connecting sensors and switches to the module IO pins or uart interface. The modules use ralink' s chip Wireless Microcontroller, allowing designers to make use of the serial interface to connect with their device Hence, this module allows designers to bring wireless applications to market in the minimum time with significantly reduced development effort and cost.

This product is an embedded module based on the universal serial interface network standard, built-in TCP / IP protocol stack, enabling the user serial port, Ethernet, wireless network (wifi) interface between the conversions. Through the MT7688KN module, the traditional serial devices do not need to change any configuration; data can be transmitted through the Internet network. Provide a quick solution for the user' s serial devices to transfer data via Ethernet Also the MT7688KN module have FCC modular approvals and is compliant with EU regulations.

The base station is a signal router, the control signal of the remote control is transmitted directly to the base station through the WIFI, enters the main controller in the hull through the signal cable, the controller decodes the signal into the corresponding control command, and then the signal is converted into the control through the central control chip The electric signal drives the motor and other equipment to complete the control action.

3. Features:

- Antenna Type: Button
- Antenna Gain(2.4GHz): 1.29db;

Transmit Power	IEEE 802.11b mode: 16.40dBm IEEE 802.11g mode: 21.90dBm IEEE 802.11n HT20 MHz mode: 21.90Bm IEEE 802.11n HT40 MHz mode: 21.00Bm
Modulation Technique	IEEE 802.11b mode: DSSS(CCK,QPSK, BPSK) IEEE 802.11g mode: OFDM (BPSK/QPSK/16QAM/64QAM) IEEE 802.11n HT20 MHz mode: OFDM (BPSK/QPSK/16QAM/64QAM) IEEE 802.11n HT40 MHz mode: OFDM (BPSK/QPSK/16QAM/64QAM)
Transmit Data Rate	IEEE 802.11b: 11Mbps(CCK) with fall back rates of 5.5/2/1Mbps IEEE 802.11g: 54Mbps with fall back rates of 48/36/24/18/12/9 /6Mbps IEEE 802.11n HT20: 65Mbps with fall back rates of 65/58.5/52/ 39/26/19.5/13/6.5Mbps IEEE 802.11n HT40: 135Mbps with fall back rates of 135/121.5/108/ 81/54/40.5/27/13.5Mbps
Number Channels	of IEEE 802.11b mode: 11 Channels IEEE 802.11g mode: 11 Channels IEEE 802.11n HT20 MHz mode: 11 Channels IEEE 802.11n HT40 MHz mode: 7 Channels
Antenna Specification	Chip Antenna with 1.29dBi gain (Max)
Channels Spacing	IEEE 802.11b/g ,802.11n HT20/HT40 : 5MHz
Temperature Range	-10°C ~ +60°C
Hardware Version	V1.0-H
Software Version	V1.0-S

Manufacturing tolerance

IEEE 802.11 b (AVG)			
Frequency (MHz)	2412	2437	2462
Target (dBm)	13.0	14.0	14.0
Tolerance ±(dB)	1.0	1.0	1.0

IEEE 802.11 g (Average)			
Frequency (MHz)	2412	2437	2462
Target (dBm)	13.0	13.0	14.0
Tolerance ±(dB)	1.0	1.0	1.0

IEEE 802.11 n HT20 (AVG)			
Frequency (MHz)	2412	2437	2462
Target (dBm)	13.0	13.0	14.0
Tolerance \pm (dB)	1.0	1.0	1.0

IEEE 802.11 n HT40 (AVG)			
Frequency (MHz)	2422	2437	2452
Target (dBm)	13.0	13.0	13.0
Tolerance \pm (dB)	1.0	1.0	1.0

