



FCC RF Test Report

APPLICANT : Mighty Audio, Inc.
EQUIPMENT : Mighty Audio Device
BRAND NAME : Mighty
MODEL NAME : M1
MARKETING NAME : M1
FCC ID : 2AKBCB00SCH16
STANDARD : FCC Part 15 Subpart C §15.247
CLASSIFICATION : (DTS) Digital Transmission System

The product was received on Oct. 11, 2016 and testing was completed on Jan. 10, 2017. We, SPORTON INTERNATIONAL INC., would like to declare that the tested sample has been evaluated in accordance with the test procedures and has been in compliance with the applicable technical standards.

The test results in this report apply exclusively to the tested model / sample. Without written approval of SPORTON INTERNATIONAL INC., the test report shall not be reproduced except in full.

Reviewed by: Joseph Lin / Supervisor

Approved by: Jones Tsai / Manager



SPORTON INTERNATIONAL INC.

No. 52, Hwa Ya 1st Rd., Hwa Ya Technology Park, Kwei-Shan District, Tao Yuan City, Taiwan, R.O.C.

SPORTON INTERNATIONAL INC.

TEL : 886-3-327-3456

FAX : 886-3-328-4978

FCC ID : 2AKBCB00SCH16

Page Number : 1 of 33

Report Issued Date : Jan. 18, 2017

Report Version : Rev. 01

Report Template No.: BU5-FR15CWL Version 2.0



TABLE OF CONTENTS

REVISION HISTORY.....3

SUMMARY OF TEST RESULT4

1 GENERAL DESCRIPTION5

 1.1 Applicant5

 1.2 Manufacturer5

 1.3 Product Feature of Equipment Under Test.....5

 1.4 Modification of EUT5

 1.5 Testing Location6

 1.6 Applicable Standards.....6

2 TEST CONFIGURATION OF EQUIPMENT UNDER TEST7

 2.1 Carrier Frequency and Channel7

 2.2 Test Mode7

 2.3 Connection Diagram of Test System8

 2.4 Support Unit used in test configuration and system9

 2.5 EUT Operation Test Setup9

 2.6 Measurement Results Explanation Example.....9

3 TEST RESULT 10

 3.1 6dB and 99% Bandwidth Measurement 10

 3.2 Output Power Measurement..... 12

 3.3 Power Spectral Density Measurement 13

 3.4 Conducted Band Edges and Spurious Emission Measurement 15

 3.5 Band Edges and Spurious Emissions in the Restricted Band.....25

 3.6 AC Conducted Emission Measurement.....29

 3.7 Antenna Requirements31

4 LIST OF MEASURING EQUIPMENT32

5 UNCERTAINTY OF EVALUATION33

APPENDIX A. CONDUCTED TEST RESULTS

APPENDIX B. AC CONDUCTED EMISSION TEST RESULT

APPENDIX C. RADIATED SPURIOUS EMISSION

APPENDIX D. RADIATED SPURIOUS EMISSION PLOTS

APPENDIX E. CONDUCTED SPURIOUS EMISSION (RESTRICTED BAND)

APPENDIX F. CONDUCTED SPURIOUS EMISSION PLOTS (RESTRICTED BAND)

APPENDIX G. SETUP PHOTOGRAPHS



REVISION HISTORY

REPORT NO.	VERSION	DESCRIPTION	ISSUED DATE
FR6O1109B	Rev. 01	Initial issue of report	Jan. 18, 2017



SUMMARY OF TEST RESULT

Report Section	FCC Rule	Description	Limit	Result	Remark
3.1	15.247(a)(2)	6dB Bandwidth	$\geq 0.5\text{MHz}$	Pass	-
3.1	-	99% Bandwidth	-	Pass	-
3.2	15.247(b)	Power Output Measurement	$\leq 30\text{dBm}$	Pass	-
3.3	15.247(e)	Power Spectral Density	$\leq 8\text{dBm}/3\text{kHz}$	Pass	-
3.4	15.247(d)	Conducted Band Edges	$\leq 20\text{dBc}$	Pass	-
		Conducted Spurious Emission		Pass	-
3.5	15.247(d)	Band Edges and Radiated Spurious Emission	15.209(a) & 15.247(d)	Pass	Under limit 3.06 dB at 38.370 MHz
3.6	15.207	AC Conducted Emission	15.207(a)	Pass	Under limit 11.80 dB at 0.166 MHz
3.7	15.203 & 15.247(b)	Antenna Requirement	N/A	Pass	-



1 General Description

1.1 Applicant

Mighty Audio, Inc.
707 Coeur d'Alene Ave, Venice, CA 90291 USA

1.2 Manufacturer

Dongguanhuang Fu Electronic Technology Co., LTD
ChuTang ChinXiaoTang Industrial Zone, FengGang, DongGuang, GuangDong, China Postcode 523682

1.3 Product Feature of Equipment Under Test

Bluetooth, DTS b/g/n

Product Specification subjective to this standard	
Antenna Type	WLAN: Chip Antenna Bluetooth: Chip Antenna

1.4 Modification of EUT

No modifications are made to the EUT during all test items.



1.5 Testing Location

Sporton Lab is accredited to ISO 17025 by Taiwan Accreditation Foundation (TAF code : 1190) and the FCC designation No. TW1022 under the FCC 2.948(e) by Mutual Recognition Agreement (MRA) in FCC Test.

Test Site	SPORTON INTERNATIONAL INC.	
Test Site Location	No. 52, Hwa Ya 1 st Rd., Hwa Ya Technology Park, Kwei-Shan District, Tao Yuan City, Taiwan, R.O.C. TEL: +886-3-327-3456 FAX: +886-3-328-4978	
Test Site No.	Sporton Site No.	
	TH02-HY	CO05-HY

Note: The test site complies with ANSI C63.4 2014 requirement.

Test Site	SPORTON INTERNATIONAL INC.	
Test Site Location	No.58, Aly. 75, Ln. 564, Wenhua 3rd Rd. Guishan Dist, Taoyuan City, Taiwan (R.O.C.) TEL: +886-3-327-0868 FAX: +886-3-327-0855	
Test Site No.	Sporton Site No.	
	03CH11-HY	03CH13-HY

Note: The test site complies with ANSI C63.4 2014 requirement.

1.6 Applicable Standards

According to the specifications of the manufacturer, the EUT must comply with the requirements of the following standards:

- ♦ FCC Part 15 Subpart C §15.247
- ♦ FCC KDB Publication No. 558074 D01 DTS Meas. Guidance v03r05
- ♦ ANSI C63.10-2013

Remark:

1. All test items were verified and recorded according to the standards and without any deviation during the test.
2. This EUT has also been tested and complied with the requirements of FCC Part 15, Subpart B, recorded in a separate test report.



2 Test Configuration of Equipment Under Test

- a. The EUT has been associated with peripherals and configuration operated in a manner tended to maximize its emission characteristics in a typical application. Frequency range investigated: conduction emission (150 kHz to 30 MHz), radiation emission (9 kHz to the 10th harmonic of the highest fundamental frequency or to 40 GHz, whichever is lower). For radiated measurement, pre-scanned in three orthogonal panels, X, Y, Z. The worst cases (X plane) were recorded in this report.
- b. AC power line Conducted Emission was tested under maximum output power.

2.1 Carrier Frequency and Channel

Frequency Band	Channel	Freq. (MHz)	Channel	Freq. (MHz)
2400-2483.5 MHz	1	2412	7	2442
	2	2417	8	2447
	3	2422	9	2452
	4	2427	10	2457
	5	2432	11	2462
	6	2437	-	-

2.2 Test Mode

Final test mode of conducted test items and radiated spurious emissions are considering the modulation and worse data rates as below table.

Modulation	Data Rate
802.11b	1 Mbps
802.11g	6 Mbps
802.11n HT20	MCS0

Test Cases	
AC Conducted Emission	Mode 1: WLAN Link + 3.5mm audio jack to USB Cable (Charging from Notebook) + Bluetooth Link

2.3 Connection Diagram of Test System

<WLAN Tx Mode>

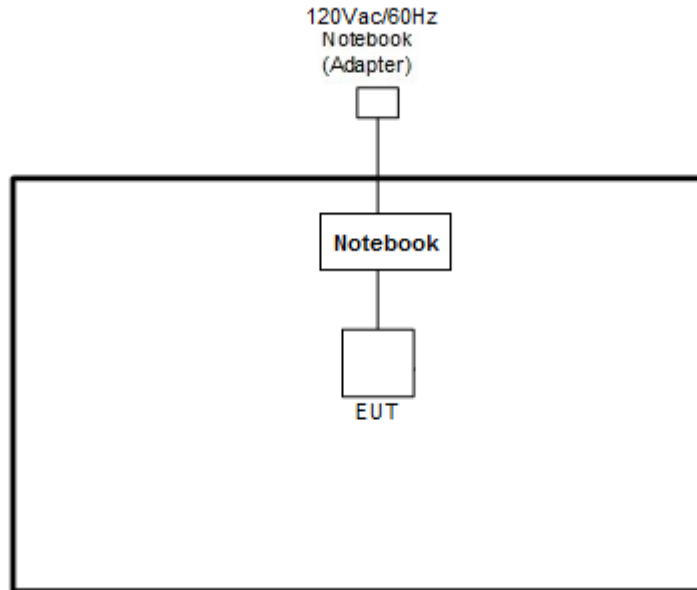

<AC Conducted Emission Mode>

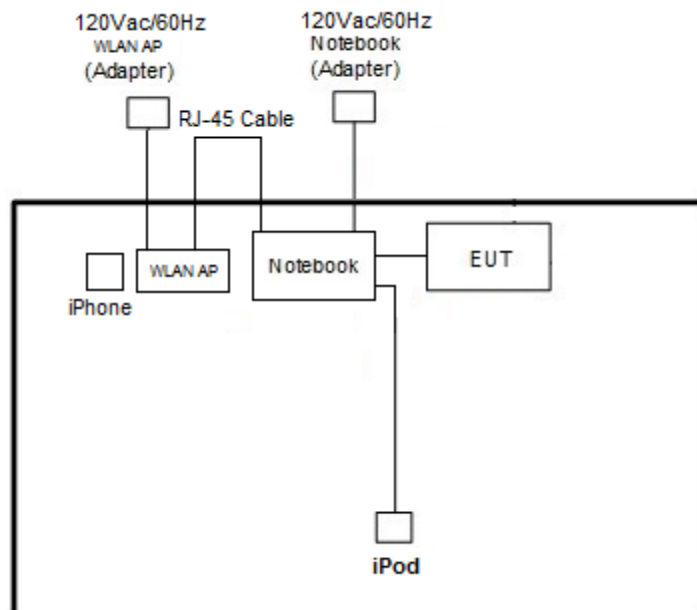

2.4 Support Unit used in test configuration and system

Item	Equipment	Trade Name	Model Name	FCC ID	Data Cable	Power Cord
1.	WLAN AP	ASUS	RT-AC66U	MSQ-RTAC66U	N/A	Unshielded, 1.8 m
2.	iPod	Apple	A1285	FCC DoC	Shielded, 1.0 m	N/A
3.	Notebook-53	ASUS	K42J	N/A	N/A	AC I/P: Unshielded, 1.2 m DC O/P: Shielded, 1.8 m
4.	Notebook	DELL	Latitude E6320	FCC DoC/ Contains FCC ID: QDS-BRCM1054	N/A	AC I/P: Unshielded, 1.2 m DC O/P: Shielded, 1.8 m
5.	iPhone	Apple	A1387	BCG-E2816A	N/A	N/A

2.5 EUT Operation Test Setup

For WLAN function, EUT links to the companion AP and ping to generate traffic for continuous transmitting and receiving signals.

2.6 Measurement Results Explanation Example

For all conducted test items:

The offset level is set in the spectrum analyzer to compensate the RF cable loss and attenuator factor between EUT conducted output port and spectrum analyzer. With the offset compensation, the spectrum analyzer reading level is exactly the EUT RF output level.

Example :

The spectrum analyzer offset is derived from RF cable loss and attenuator factor.

Offset = RF cable loss + attenuator factor.

Following shows an offset computation example with cable loss 4.2 dB and 10dB attenuator.

$$\begin{aligned}
 \text{Offset(dB)} &= \text{RF cable loss(dB)} + \text{attenuator factor(dB)}. \\
 &= 4.2 + 10 = 14.2 \text{ (dB)}
 \end{aligned}$$

3 Test Result

3.1 6dB and 99% Bandwidth Measurement

3.1.1 Limit of 6dB and 99% Bandwidth

The minimum 6 dB bandwidth shall be at least 500 kHz.

3.1.2 Measuring Instruments

The measuring equipment is listed in the section 4 of this test report.

3.1.3 Test Procedures

1. The testing follows FCC KDB Publication No. 558074 DTS D01 Meas. Guidance v03r05.
2. The RF output of EUT was connected to the spectrum analyzer by RF cable and attenuator. The path loss was compensated to the results for each measurement.
3. Set to the maximum power setting and enable the EUT transmit continuously.
4. Make the measurement with the spectrum analyzer's resolution bandwidth (RBW) = 100 kHz. Set the Video bandwidth (VBW) = 300 kHz. In order to make an accurate measurement. The 6 dB bandwidth must be greater than 500 kHz.
5. For 99% Bandwidth Measurement, the spectrum analyzer's resolution bandwidth (RBW) = 1MHz and set the Video bandwidth (VBW) = 3MHz.
6. Measure and record the results in the test report.

3.1.4 Test Setup

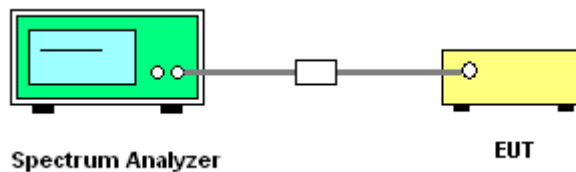



3.1.5 Test Result of 6dB and 99% Occupied Bandwidth

Please refer to Appendix A.

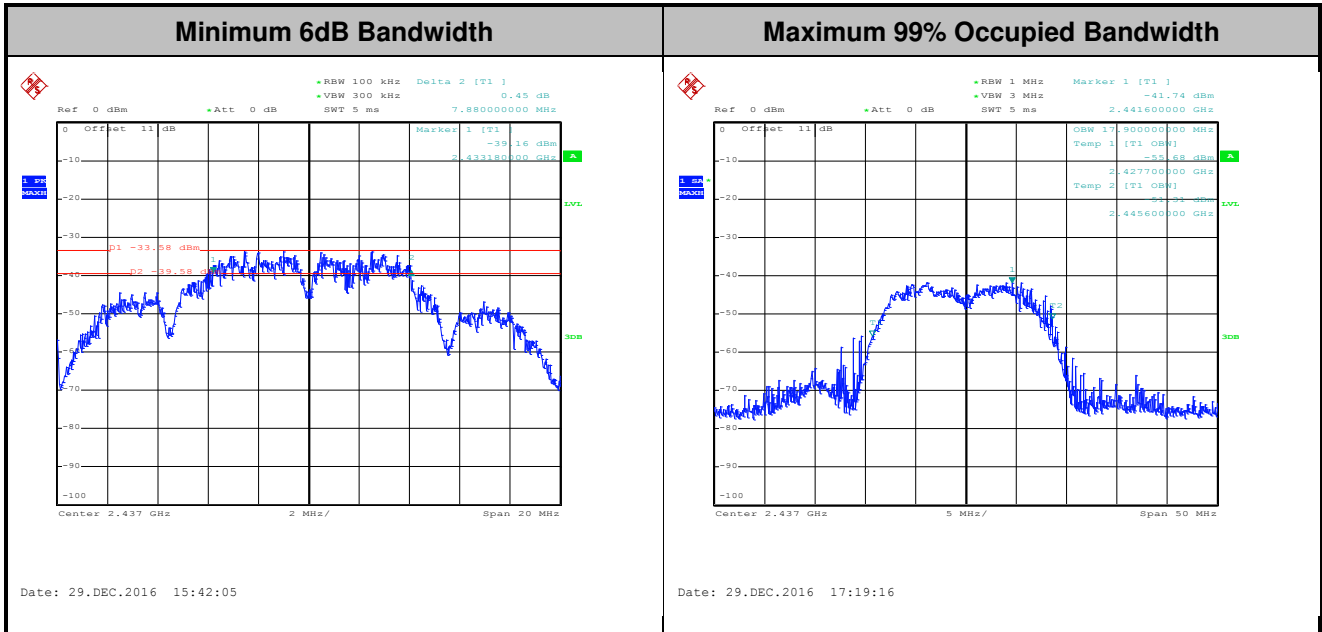

Note : The occupied channel bandwidth is maintained within the band of operation for all of the modulations.

3.2 Output Power Measurement

3.2.1 Limit of Output Power

For systems using digital modulation in the 2400-2483.5MHz, the limit for peak output power is 30dBm. If transmitting antenna of directional gain greater than 6dBi are used the peak output power from the intentional radiator shall be reduced below the above stated value by the amount in dB that the directional gain of the antenna exceeds 6 dBi. In case of point-to-point operation, the limit has to be reduced by 1dB for every 3dB that the directional gain of the antenna exceeds 6dBi.

3.2.2 Measuring Instruments

The measuring equipment is listed in the section 4 of this test report.

3.2.3 Test Procedures

1. The testing follows the Measurement Procedure of FCC KDB No. 558074 DTS D01 Meas. Guidance v03r05 section 9.1.2 PKPM1 Peak power meter method.
2. The RF output of EUT was connected to the power meter by RF cable and attenuator. The path loss was compensated to the results for each measurement.
3. Set to the maximum power setting and enable the EUT transmit continuously.
4. Measure the conducted output power and record the results in the test report.

3.2.4 Test Setup

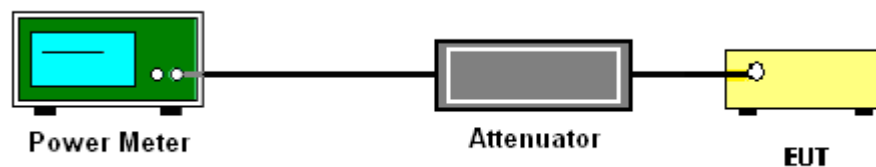

3.2.5 Test Result of Peak Output Power

Please refer to Appendix A.

3.2.6 Test Result of Average output Power (Reporting Only)

Please refer to Appendix A.

3.3 Power Spectral Density Measurement

3.3.1 Limit of Power Spectral Density

The peak power spectral density shall not be greater than 8dBm in any 3kHz band at any time interval of continuous transmission.

3.3.2 Measuring Instruments

The measuring equipment is listed in the section 4 of this test report.

3.3.3 Test Procedures

1. The testing follows Measurement Procedure 10.2 Method PKPSD of FCC KDB Publication No. 558074 D01 DTS Meas. Guidance v03r05
2. The RF output of EUT was connected to the spectrum analyzer by RF cable and attenuator. The path loss was compensated to the results for each measurement.
3. Set to the maximum power setting and enable the EUT transmit continuously.
4. Make the measurement with the spectrum analyzer's resolution bandwidth (RBW) = 100 kHz. Video bandwidth VBW = 300 kHz In order to make the worst case measurement, set the span to 1.5 times DTS Channel Bandwidth. (6dB BW)
5. Detector = peak, Sweep time = auto couple, Trace mode = max hold, Allow trace to fully stabilize. Use the peak marker function to determine the maximum power level.
6. Measure and record the results in the test report.

3.3.4 Test Setup

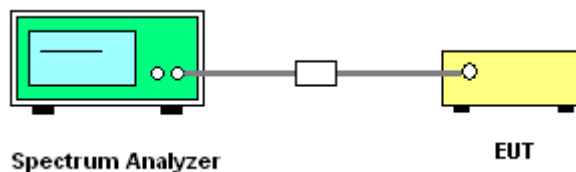



3.3.5 Test Result of Power Spectral Density

Please refer to Appendix A.

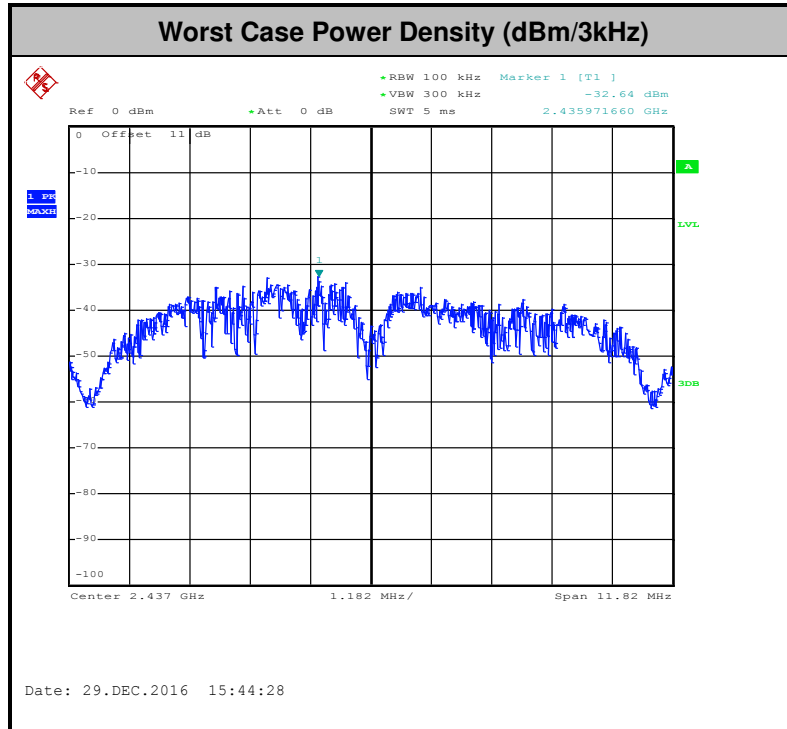

3.4 Conducted Band Edges and Spurious Emission Measurement

3.4.1 Limit of Conducted Band Edges and Spurious Emission Measurement

In any 100 kHz bandwidth outside of the authorized frequency band, the emissions which fall in the non-restricted bands shall be attenuated at least 20 dB / 30dB relative to the maximum PSD level in 100 kHz by RF conducted measurement and radiated emissions which fall in the restricted bands, as defined in Section 15.205(a), must also comply with the radiated emission limits specified in Section 15.209(a).

3.4.2 Measuring Instruments

The measuring equipment is listed in the section 4 of this test report.

3.4.3 Test Procedures

1. The testing follows FCC KDB Publication No. 558074 D01 DTS Meas. Guidance v03r05.
2. The RF output of EUT was connected to the spectrum analyzer by RF cable and attenuator. The path loss was compensated to the results for each measurement.
3. Set to the maximum power setting and enable the EUT transmit continuously.
4. Set RBW = 100 kHz, VBW=300 kHz, Peak Detector. Unwanted Emissions measured in any 100 kHz bandwidth outside of the authorized frequency band shall be attenuated by at least 20 dB relative to the maximum in-band peak PSD level in 100 kHz when maximum peak conducted output power procedure is used. If the transmitter complies with the conducted power limits based on the use of RMS averaging over a time interval, the attenuation required under this paragraph shall be 30 dB instead of 20 dB per 15.247(d).
5. Measure and record the results in the test report.
6. The RF fundamental frequency should be excluded against the limit line in the operating frequency band.

3.4.4 Test Setup

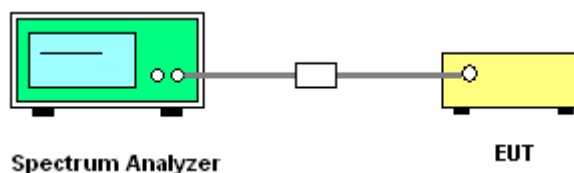



3.4.5 Test Result of Conducted Band Edges and Spurious Emission

Test Mode :	802.11b	Temperature :	21~25°C
Test Band :	2.4GHz Low	Relative Humidity :	51~54%
Test Channel :	01	Test Engineer :	AC Chang

WLAN 802.11b Channel 01

100kHz PSD reference Level	Low Channel Plot
-----------------------------------	-------------------------

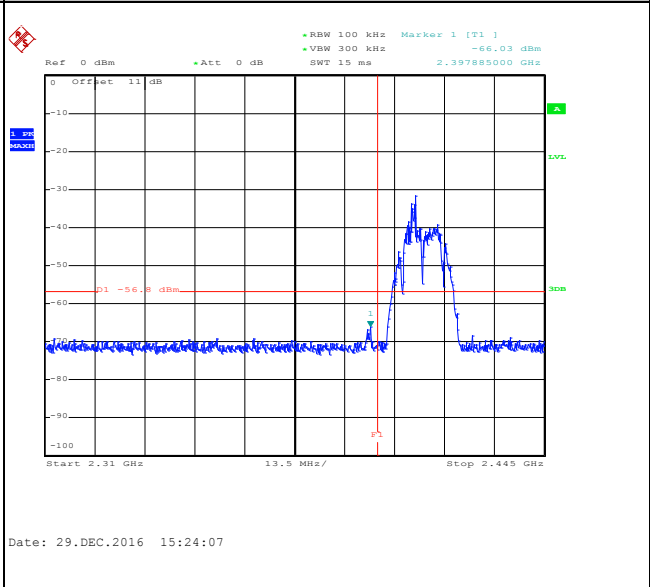
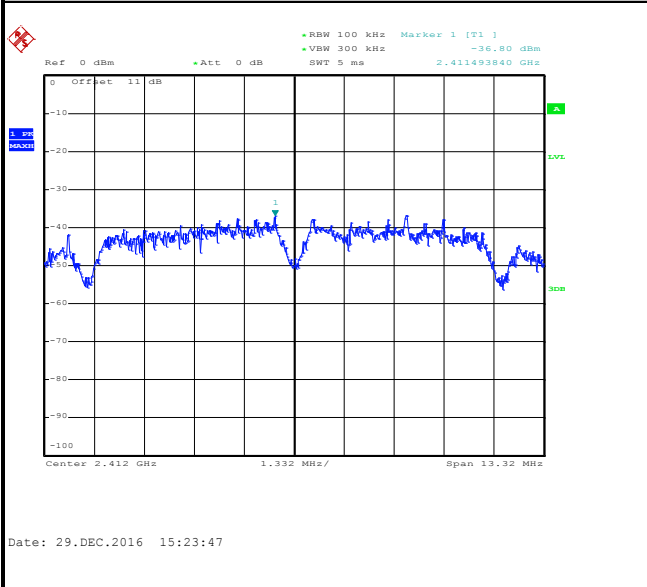

Spurious Emission 30MHz~3GHz

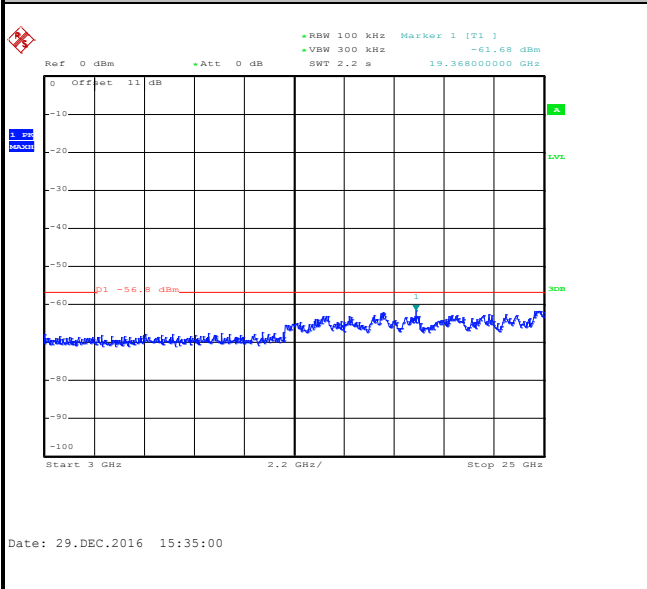

Spurious Emission 2GHz~25GHz

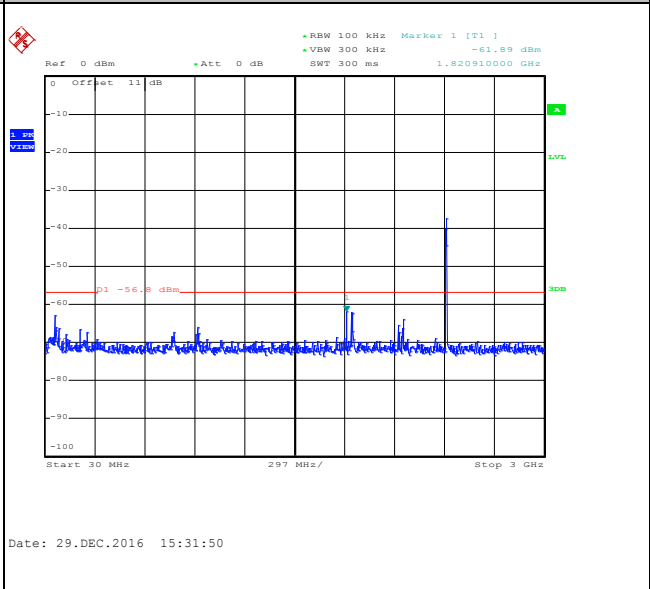



Test Mode :	802.11b	Temperature :	21~25°C
Test Band :	2.4GHz Mid	Relative Humidity :	51~54%
Test Channel :	06	Test Engineer :	AC Chang

WLAN 802.11b Channel 06

100kHz PSD reference Level

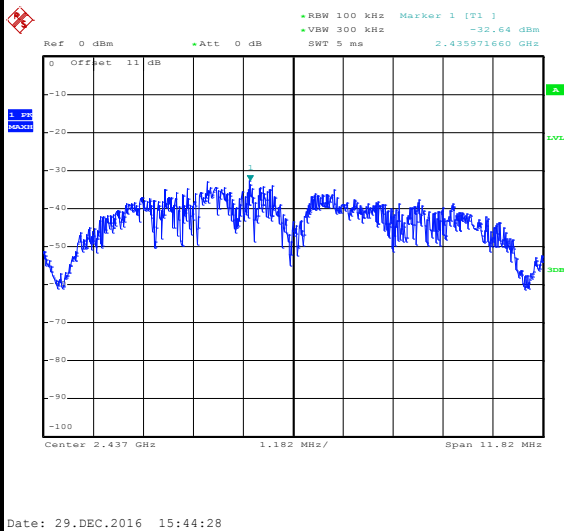

Spurious Emission 30MHz~3GHz

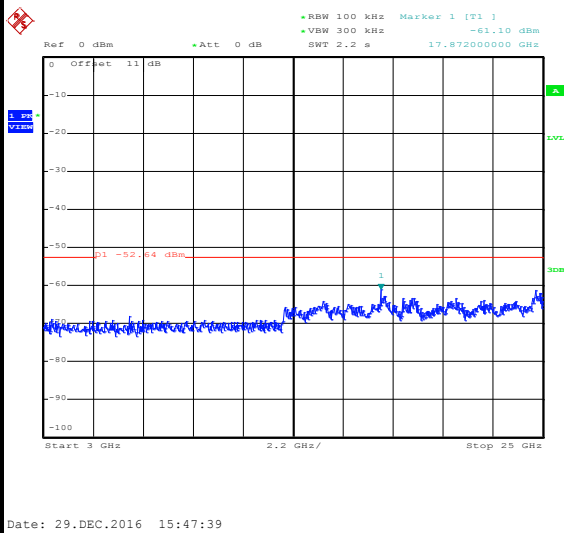

Spurious Emission 2GHz~25GHz

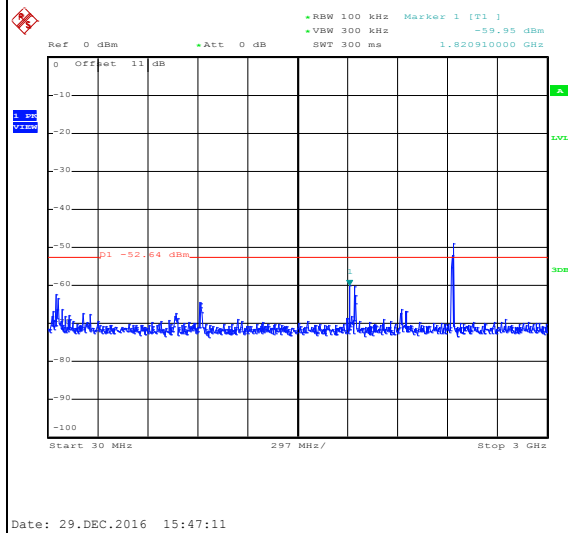



Test Mode :	802.11b	Temperature :	21~25°C
Test Band :	2.4GHz High	Relative Humidity :	51~54%
Test Channel :	11	Test Engineer :	AC Chang

WLAN 802.11b Channel 11

100kHz PSD reference Level

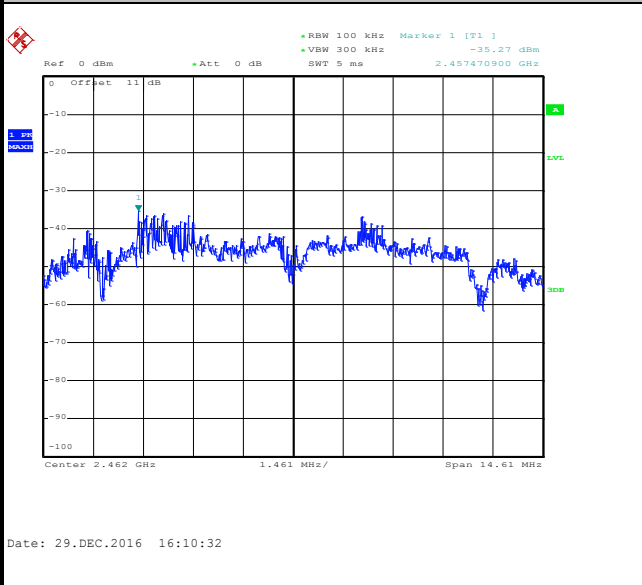

High Channel Plot

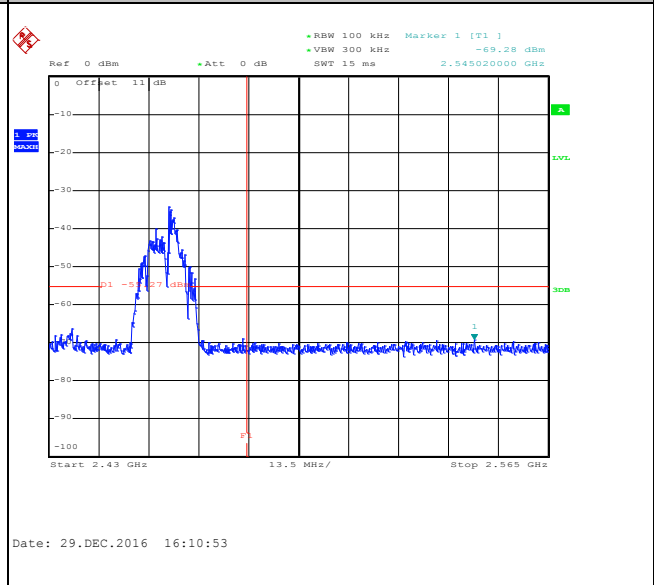

Spurious Emission 30MHz~3GHz

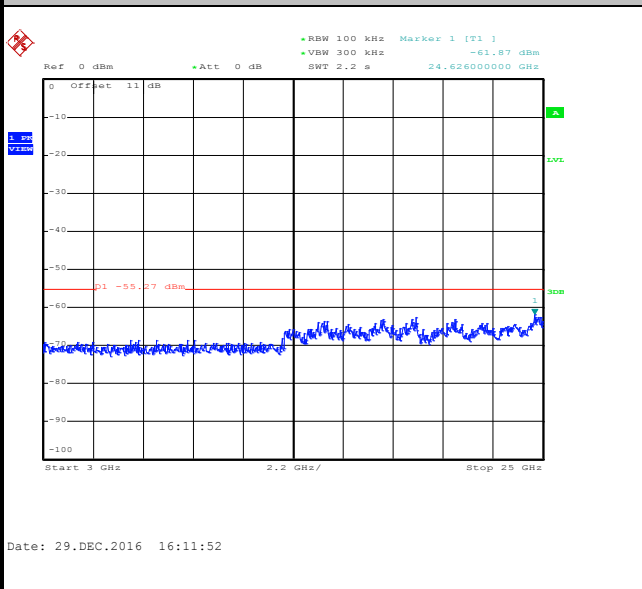

Spurious Emission 2GHz~25GHz

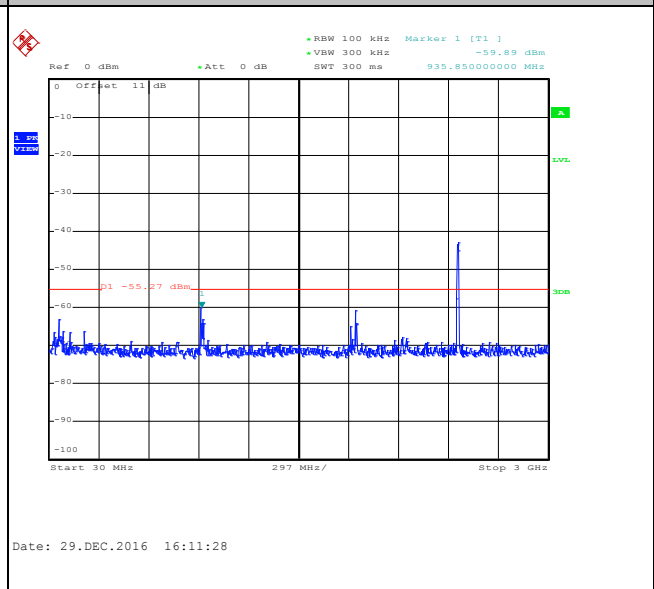



Test Mode :	802.11g	Temperature :	21~25°C
Test Band :	2.4GHz Low	Relative Humidity :	51~54%
Test Channel :	01	Test Engineer :	AC Chang

WLAN 802.11g Channel 01

100kHz PSD reference Level

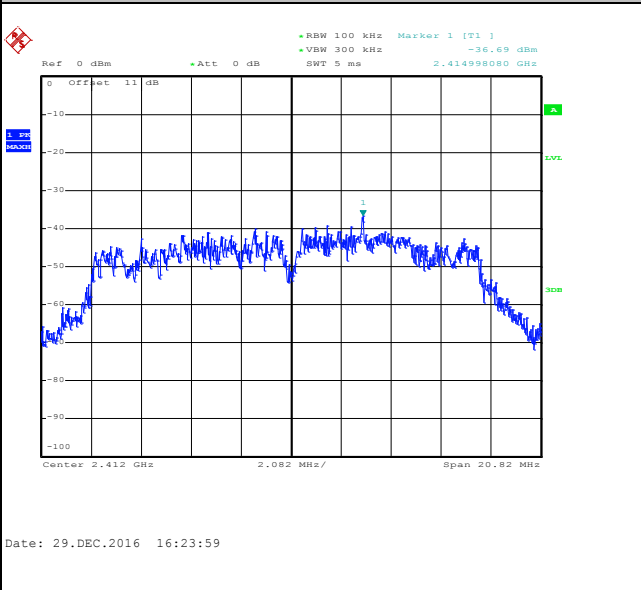

Low Channel Plot

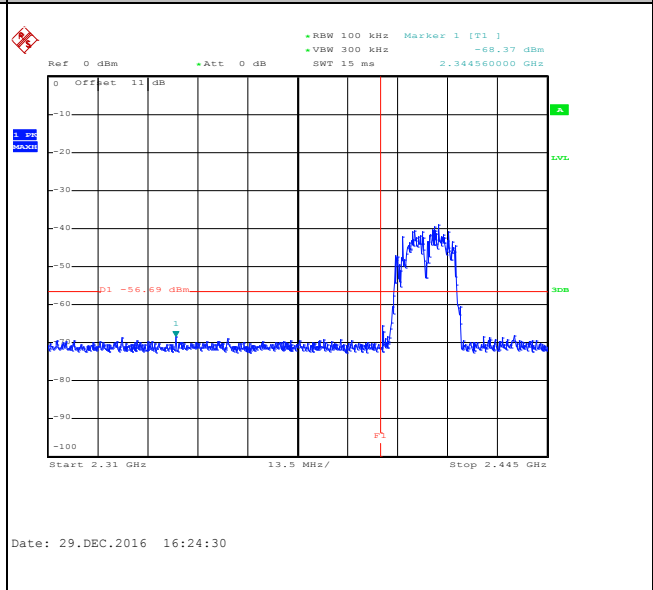

Spurious Emission 30MHz~3GHz

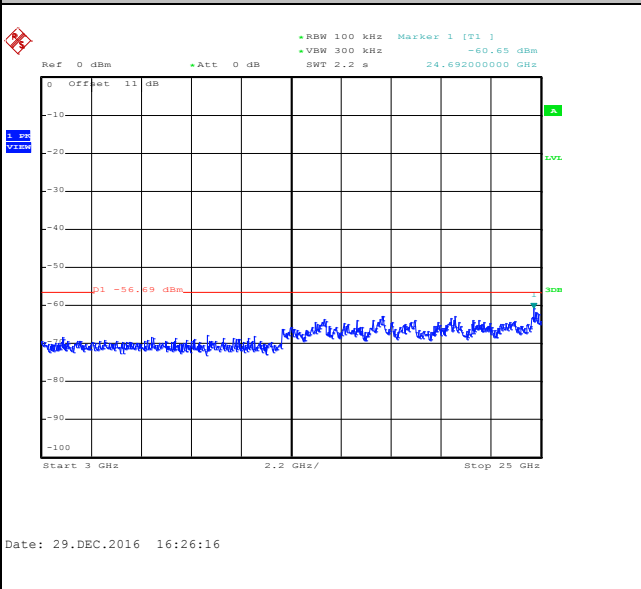

Spurious Emission 2GHz~25GHz

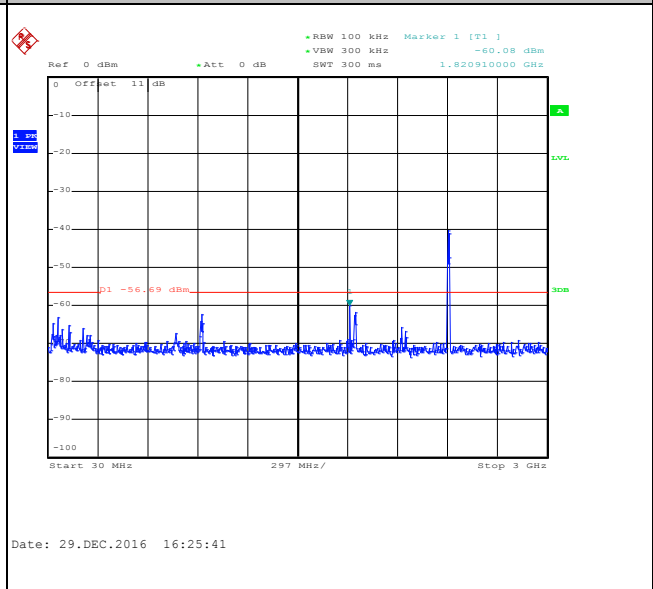



Test Mode :	802.11g	Temperature :	21~25°C
Test Band :	2.4GHz Mid	Relative Humidity :	51~54%
Test Channel :	06	Test Engineer :	AC Chang

WLAN 802.11g Channel 06

100kHz PSD reference Level

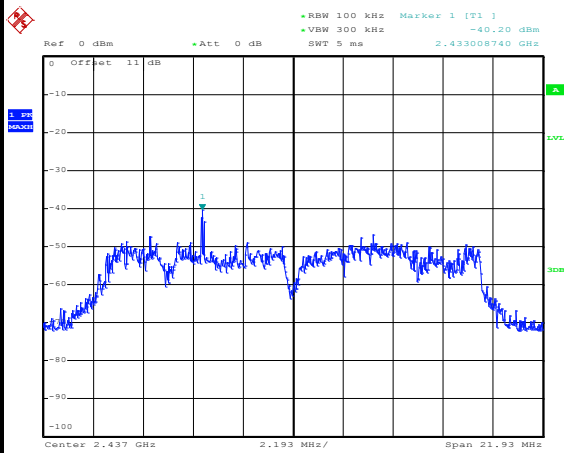

Date: 29.DEC.2016 16:31:21

Spurious Emission 30MHz~3GHz

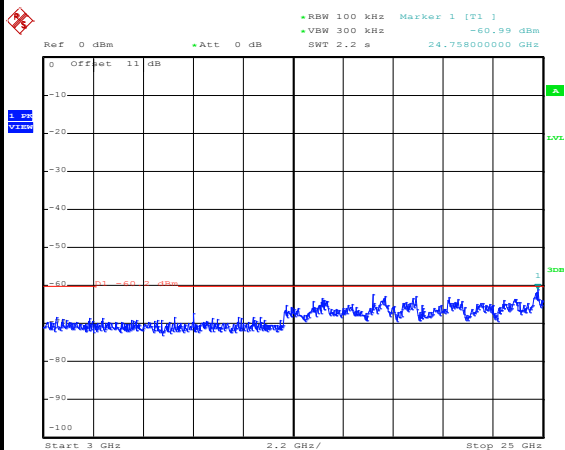

Date: 29.DEC.2016 16:32:03

Spurious Emission 2GHz~25GHz

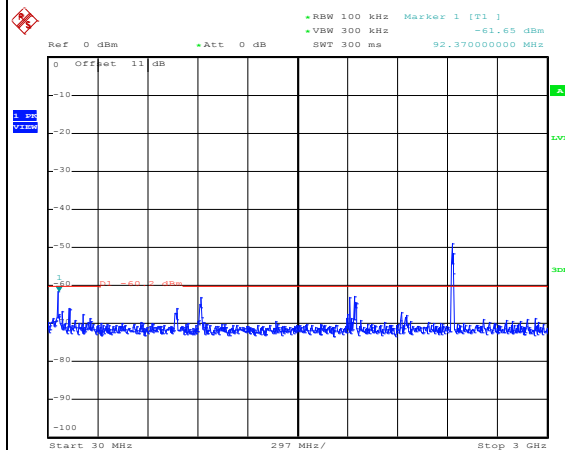

Date: 29.DEC.2016 16:31:38



Test Mode :	802.11g	Temperature :	21~25°C
Test Band :	2.4GHz High	Relative Humidity :	51~54%
Test Channel :	11	Test Engineer :	AC Chang

WLAN 802.11g Channel 11

100kHz PSD reference Level

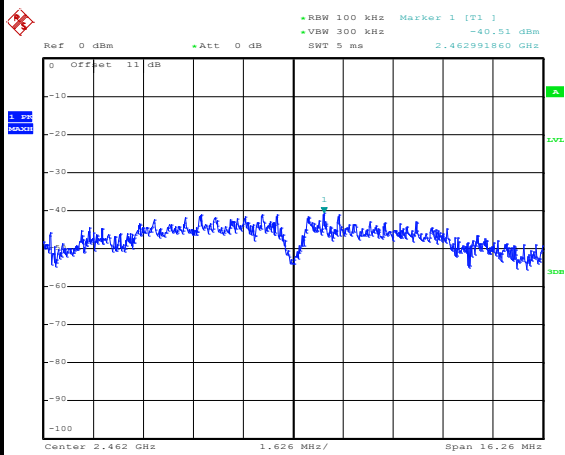

Date: 29.DEC.2016 16:38:41

High Channel Plot

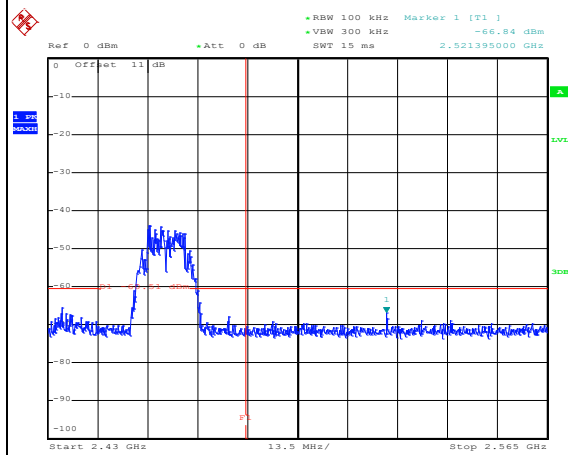

Date: 29.DEC.2016 16:39:03

Spurious Emission 30MHz~3GHz

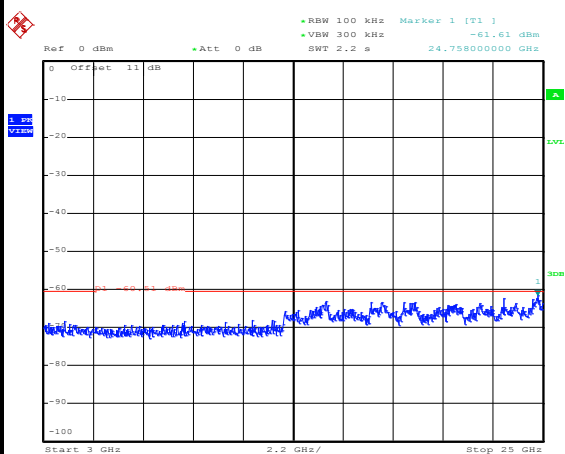

Date: 29.DEC.2016 16:40:44

Spurious Emission 2GHz~25GHz

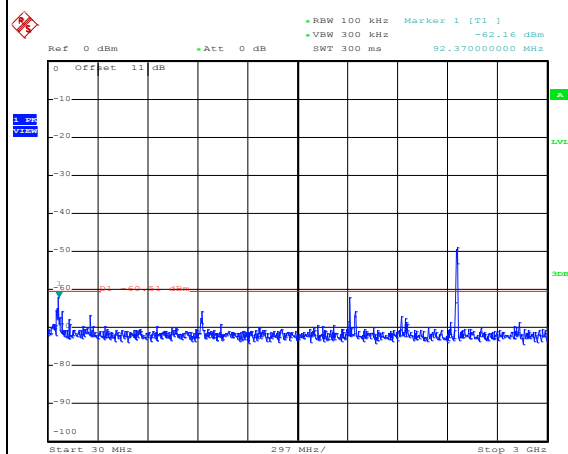

Date: 29.DEC.2016 16:40:16



Test Mode :	802.11n HT20	Temperature :	21~25°C
Test Band :	2.4GHz Low	Relative Humidity :	51~54%
Test Channel :	01	Test Engineer :	AC Chang

WLAN 802.11n HT20 Channel 01

100kHz PSD reference Level

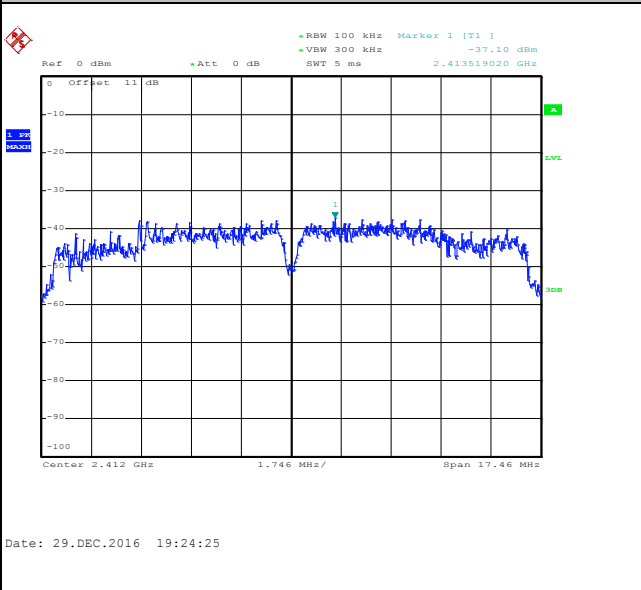

Low Channel Plot

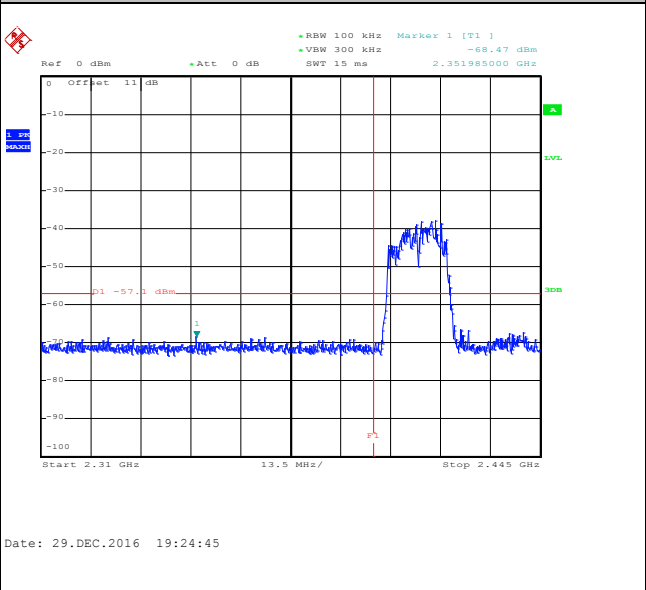

Spurious Emission 30MHz~3GHz

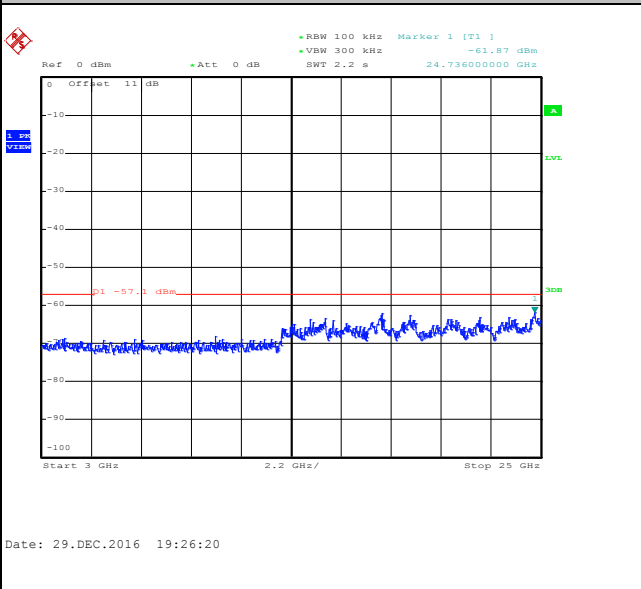

Spurious Emission 2GHz~25GHz

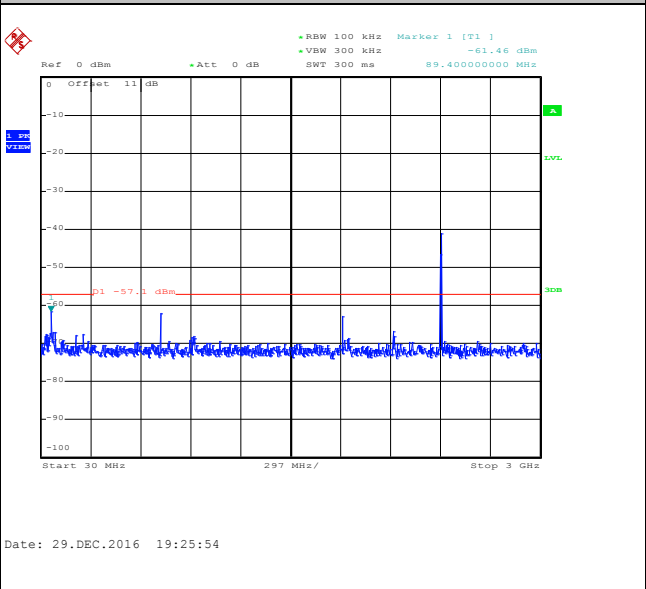



Test Mode :	802.11n HT20	Temperature :	21~25°C
Test Band :	2.4GHz Mid	Relative Humidity :	51~54%
Test Channel :	06	Test Engineer :	AC Chang

WLAN 802.11n HT20 Channel 06

100kHz PSD reference Level

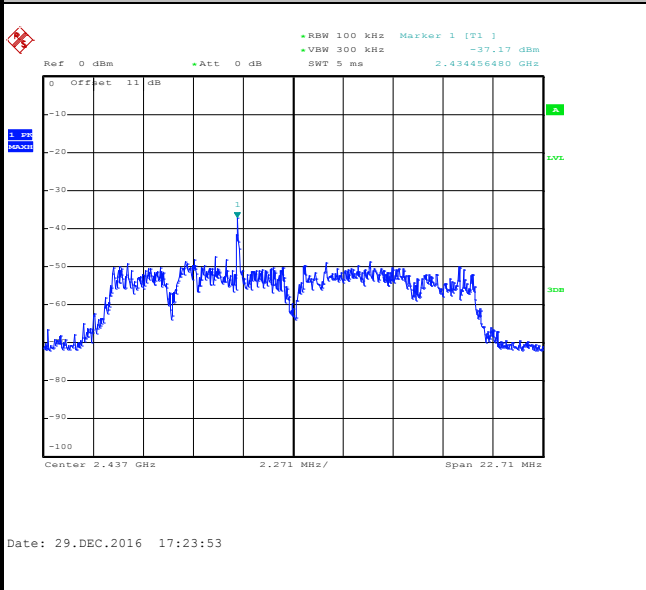

Spurious Emission 30MHz~3GHz

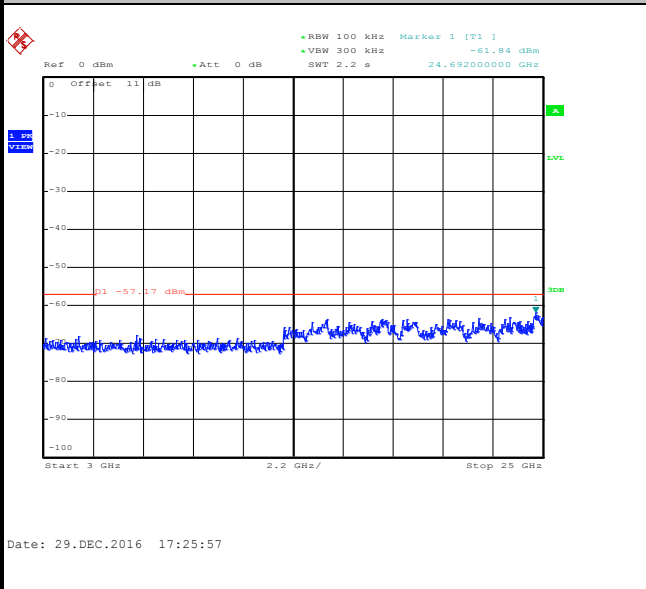

Spurious Emission 2GHz~25GHz

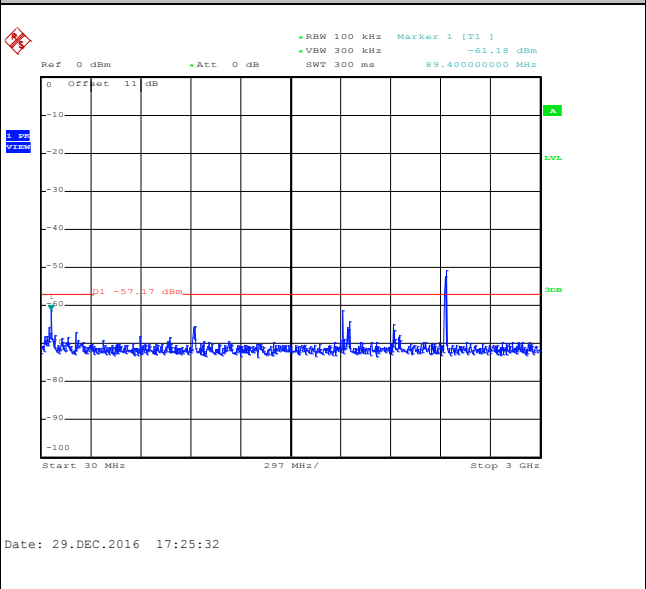



Test Mode :	802.11n HT20	Temperature :	21~25°C
Test Band :	2.4GHz High	Relative Humidity :	51~54%
Test Channel :	11	Test Engineer :	AC Chang

WLAN 802.11n HT20 Channel 11

100kHz PSD reference Level

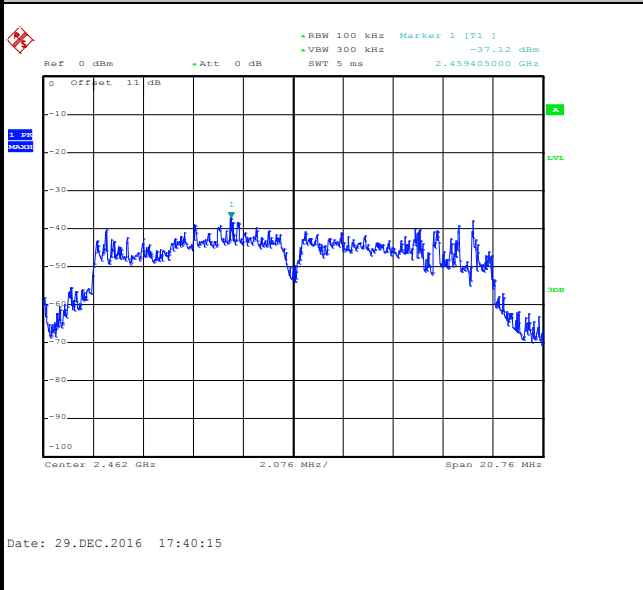

High Channel Plot

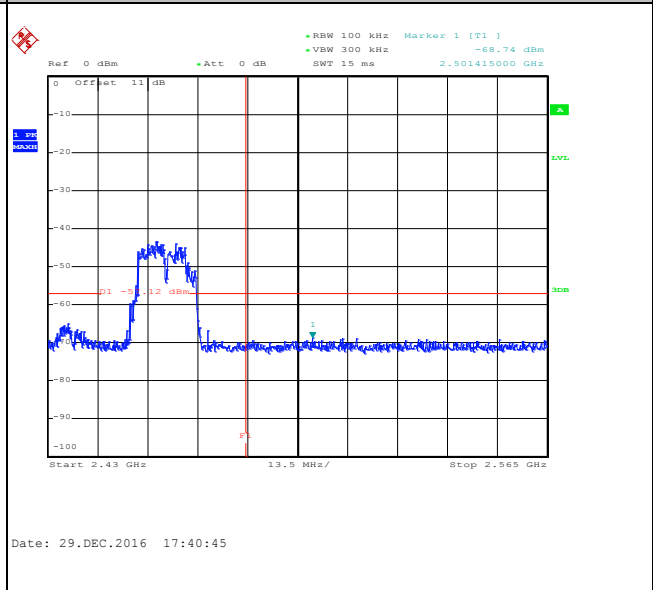

Spurious Emission 30MHz~3GHz

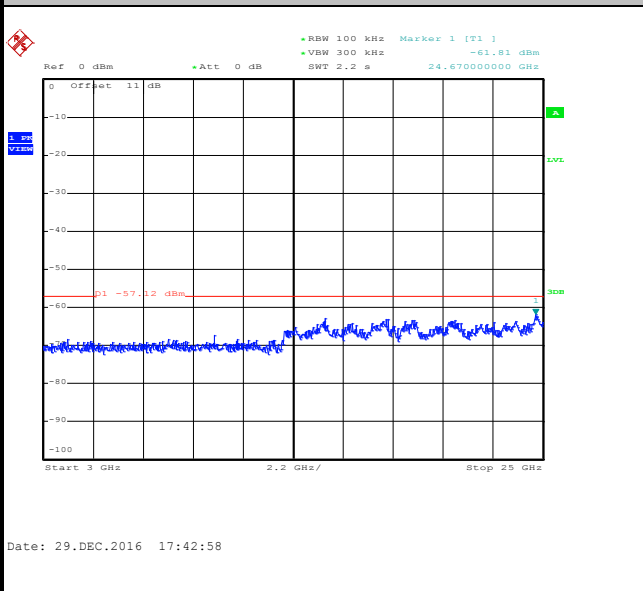

Spurious Emission 2GHz~25GHz

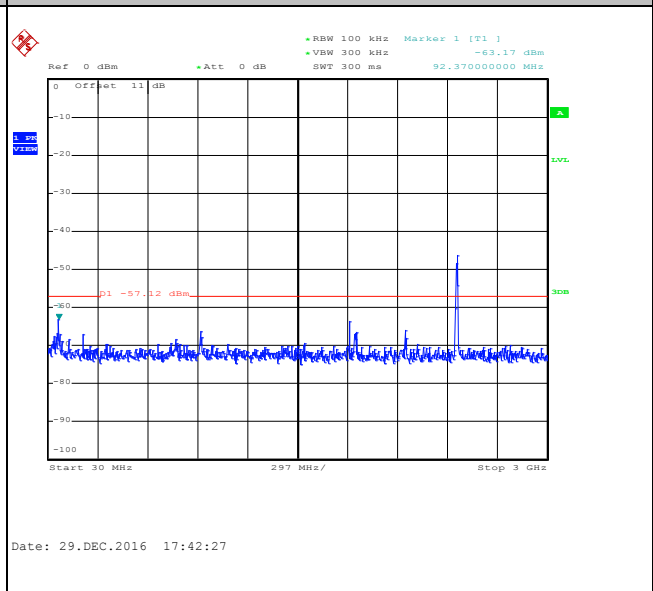



3.5 Band Edges and Spurious Emissions in the Restricted Band

3.5.1 Limit of Radiated band edge and Spurious Emission Measurement

In any 100 kHz bandwidth outside the intentional radiator frequency band, all harmonics/spurious must be at least 20 dB below the highest emission level within the authorized band. If the output power of this device was measured by spectrum analyzer, the attenuation under this paragraph shall be 30 dB instead of 20 dB. In addition, radiated emissions which fall in the restricted bands must also comply with the FCC section 15.209 limits as below.

Frequency (MHz)	Field Strength (microvolts/meter)	Measurement Distance (meters)
0.009 – 0.490	2400/F(kHz)	300
0.490 – 1.705	24000/F(kHz)	30
1.705 – 30.0	30	30
30 – 88	100	3
88 – 216	150	3
216 - 960	200	3
Above 960	500	3

3.5.2 Measuring Instruments

The measuring equipment is listed in the section 4 of this test report.



3.5.3 Test Procedures

1. The testing follows FCC KDB Publication No. 558074 D01 DTS Meas. Guidance v03r05.
2. The EUT was arranged to its worst case and then tune the antenna tower (from 1 m to 4 m) and turntable (from 0 degree to 360 degrees) to find the maximum reading. A pre-amp and a high pass filter are used for the test in order to get better signal level.
3. The EUT was placed on a turntable with 0.8 meter for frequency below 1GHz and 1.5 meter for frequency above 1GHz respectively above ground.
4. The EUT was set 3 meters from the interference receiving antenna, which was mounted on the top of a variable height antenna tower.
5. Corrected Reading: Antenna Factor + Cable Loss + Read Level - Preamp Factor = Level
6. For measurement below 1GHz, If the emission level of the EUT measured by the peak detector is 3 dB lower than the applicable limit, the peak emission level will be reported. Otherwise, the emission measurement will be repeated using the quasi-peak detector and reported.
7. Use the following spectrum analyzer settings:
 - (1) Span shall wide enough to fully capture the emission being measured;
 - (2) Set RBW=100 kHz for $f < 1$ GHz; VBW \geq RBW; Sweep = auto; Detector function = peak; Trace = max hold;
 - (3) Set RBW = 1 MHz, VBW= 3MHz for $f \geq 1$ GHz for peak measurement.
For average measurement:
 - VBW = 100kHz $\geq 1/T$, when duty cycle is less than 98 percent where T is the minimum transmission duration over which the transmitter is on and is transmitting at its maximum power control level for the tested mode of operation.

3.5.4 Test Setup

For Conducted Measurement Setup:

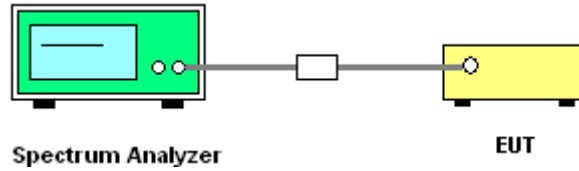

For radiated emissions below 30MHz

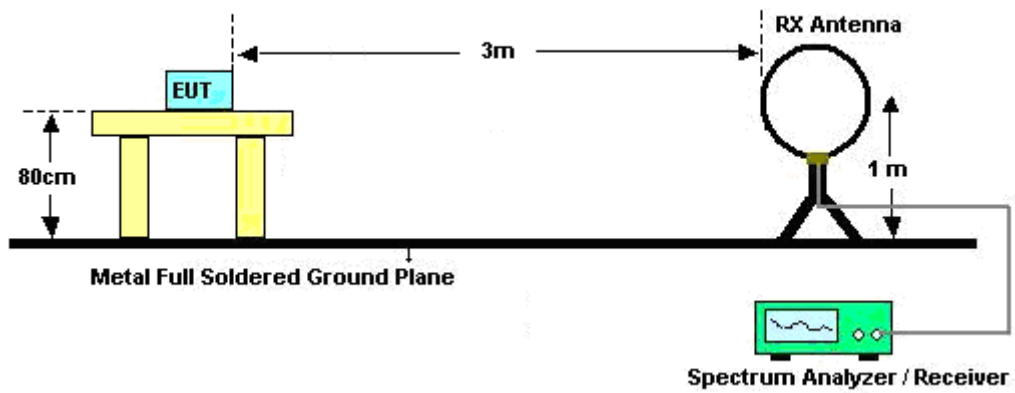

For radiated emissions from 30MHz to 1GHz

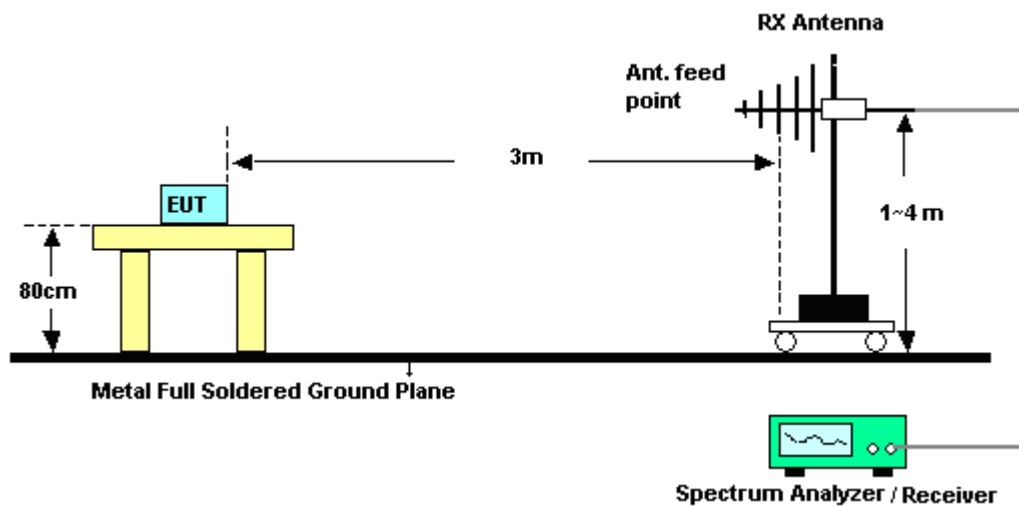

For radiated emissions above 1GHz

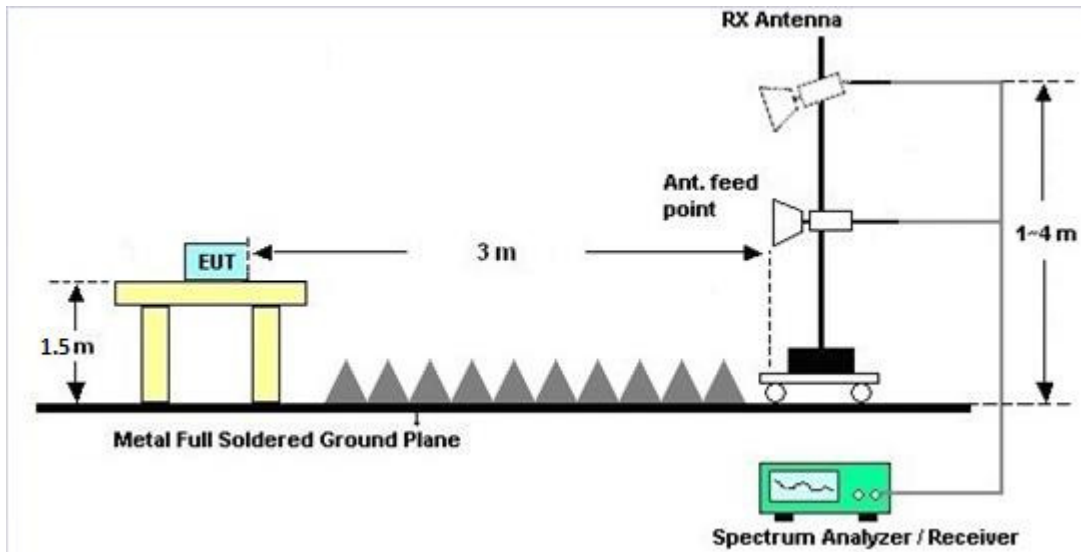

3.5.5 Test Results of Radiated Spurious Emissions (9kHz ~ 30MHz)

The low frequency, which started from 9 kHz to 30MHz, was pre-scanned and the result which was 20dB lower than the limit line per 15.31(o) was not reported.

3.5.6 Test Result of Cabinet Radiation (30MHz ~ 10th Harmonic)

Please refer to Appendix C and D.

3.5.7 Test Result of Conducted Spurious at Band Edges in the Restricted Band

Please refer to Appendix E and F.

3.5.8 Test Result of Conducted Spurious Emission in the Restricted Band

Please refer to Appendix E and F.

3.5.9 Duty Cycle

Duty cycle is non-constant and below 10% due to intended usage.



3.6 AC Conducted Emission Measurement

3.6.1 Limit of AC Conducted Emission

For equipment that is designed to be connected to the public utility (AC) power line, the radio frequency voltage that is conducted back onto the AC power line on any frequency or frequencies within the band 150 kHz to 30 MHz shall not exceed the limits in the following table.

Frequency of Emission (MHz)	Conducted Limit (dBµV)	
	Quasi-Peak	Average
0.15-0.5	66 to 56*	56 to 46*
0.5-5	56	46
5-30	60	50

*Decreases with the logarithm of the frequency.

3.6.2 Measuring Instruments

The measuring equipment is listed in the section 4 of this test report.

3.6.3 Test Procedures

1. The EUT was placed 0.4 meter from the conducting wall of the shielding room, and it was kept at least 80 centimeters from any other grounded conducting surface.
2. Connect EUT to the power mains through a line impedance stabilization network (LISN).
3. All the support units are connecting to the other LISN.
4. The LISN provides 50 ohm coupling impedance for the measuring instrument.
5. The FCC states that a 50 ohm, 50 microhenry LISN should be used.
6. Both sides of AC line were checked for maximum conducted interference.
7. The frequency range from 150 kHz to 30 MHz was searched.
8. Set the test-receiver system to Peak Detect Function and specified bandwidth (IF bandwidth = 9kHz) with Maximum Hold Mode.

3.6.4 Test Setup

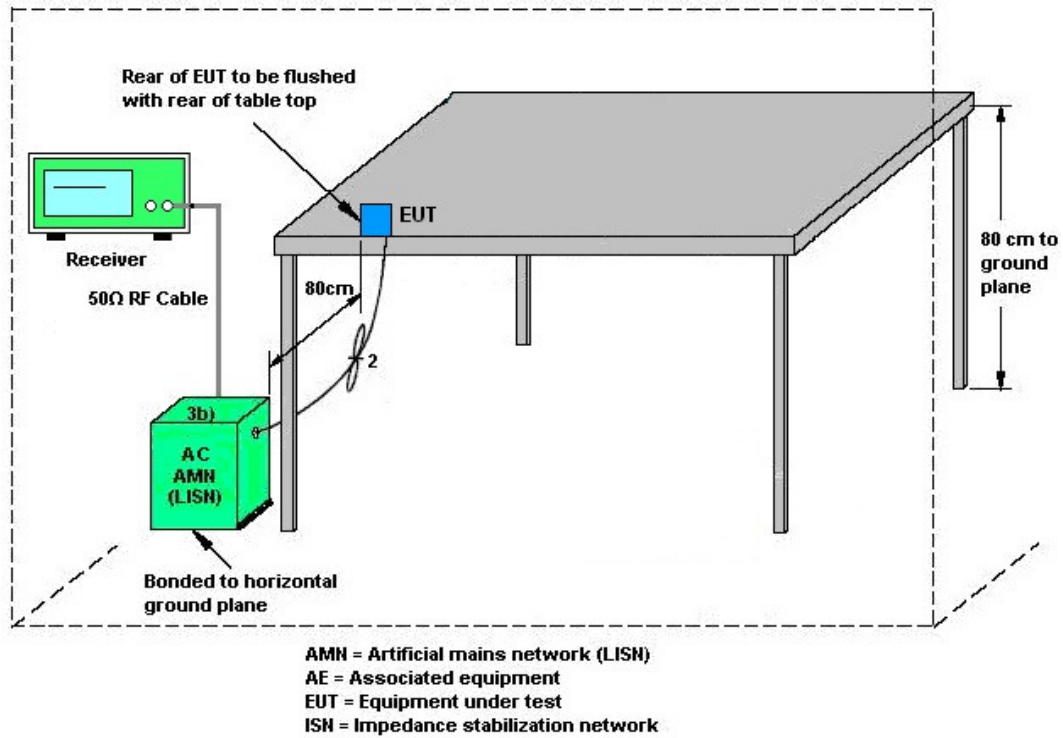

3.6.5 Test Result of AC Conducted Emission

Please refer to Appendix B.



3.7 Antenna Requirements

3.7.1 Standard Applicable

If directional gain of transmitting antennas is greater than 6dBi, the power shall be reduced by the same level in dB comparing to gain minus 6dBi. For the fixed point-to-point operation, the power shall be reduced by one dB for every 3 dB that the directional gain of the antenna exceeds 6 dBi. The use of a permanently attached antenna or of an antenna that uses a unique coupling to the intentional radiator shall be considered sufficient to comply with the FCC rule.

3.7.2 Antenna Anti-Replacement Construction

An embedded-in antenna design is used.

3.7.3 Antenna Gain

The antenna peak gain of EUT is less than 6 dBi. Therefore, it is not necessary to reduce maximum peak output power limit.



4 List of Measuring Equipment

Instrument	Manufacturer	Model No.	Serial No.	Characteristics	Calibration Date	Test Date	Due Date	Remark
Power Sensor	DARE	RPR3006W	13100030S NO32	9kHz~6GHz	Sep. 21, 2016	Dec. 29, 2016	Sep. 20, 2017	Conducted (TH02-HY)
Spectrum Analyzer	Rohde & Schwarz	FSP40	100055	9kHz~40GHz	Jun. 17, 2016	Dec. 29, 2016	Jun. 16, 2017	Conducted (TH02-HY)
BT Base Station(Measure)	Rohde & Schwarz	CBT32	100519	N/A	Jun. 03, 2016	Dec. 29, 2016	Jun. 02, 2017	Conducted (TH02-HY)
AC Power Source	ChainTek	APC-1000W	N/A	N/A	N/A	Nov. 22, 2016	N/A	Conduction (CO05-HY)
EMI Test Receiver	Rohde & Schwarz	ESCI 7	100724	9kHz~7GHz	Aug. 30, 2016	Nov. 22, 2016	Aug. 29, 2017	Conduction (CO05-HY)
LISN	Rohde & Schwarz	ENV216	100080	9kHz~30MHz	Dec. 02, 2015	Nov. 22, 2016	Dec. 01, 2016	Conduction (CO05-HY)
LISN	Rohde & Schwarz	ENV216	100081	9kHz~30MHz	Dec. 14, 2015	Nov. 22, 2016	Dec. 13, 2016	Conduction (CO05-HY)
Amplifier	SONOMA	310N	187312	9kHz~1GHz	Nov. 10, 2016	Dec. 26, 2016 ~ Dec. 27, 2016	Nov. 09, 2017	Radiation (03CH11-HY)
Loop Antenna	Rohde & Schwarz	HFH2-Z2	100315	9 kHz~30 MHz	Sep. 02, 2015	Dec. 26, 2016 ~ Dec. 27, 2016	Sep. 01, 2017	Radiation (03CH11-HY)
Bilog Antenna	TESEQ	CBL 6111D	35414	30MHz~1GHz	Oct. 15, 2016	Dec. 26, 2016 ~ Dec. 27, 2016	Oct. 14, 2017	Radiation (03CH11-HY)
Horn Antenna	SCHWARZBECK	BBHA 9120 D	9120D-152 2	1GHz ~ 18GHz	Mar. 30, 2016	Dec. 26, 2016 ~ Dec. 27, 2016	Mar. 31, 2017	Radiation (03CH11-HY)
Preamplifier	Keysight	83017A	MY532700 80	1GHz~26.5GHz	Nov. 10, 2016	Dec. 26, 2016 ~ Dec. 27, 2016	Nov. 09, 2017	Radiation (03CH11-HY)
Spectrum Analyzer	Keysight	N9010A	MY523502 76	10Hz ~ 44GHZ	Mar. 21, 2016	Dec. 26, 2016 ~ Dec. 27, 2016	Mar. 20, 2017	Radiation (03CH11-HY)
Antenna Mast	EMEC	AM-BS-4500-B	N/A	1~4m	N/A	Dec. 26, 2016 ~ Dec. 27, 2016	N/A	Radiation (03CH11-HY)
Turn Table	EMEC	TT 2000	N/A	0~360 Degree	N/A	Dec. 26, 2016 ~ Dec. 27, 2016	N/A	Radiation (03CH11-HY)
Preamplifier	MITEQ	TTA0204	1872107	2GHz~40GHz	Feb. 15, 2016	Dec. 26, 2016 ~ Dec. 27, 2016	Feb. 14, 2017	Radiation (03CH11-HY)
SHF-EHF Horn Antenna	SCHWARZBECK	BBHA 9170	BBHA9170 584	18GHz- 40GHz	Nov. 08, 2016	Dec. 26, 2016 ~ Dec. 27, 2016	Nov. 07, 2017	Radiation (03CH11-HY)
Preamplifier	Keysight	83017A	MY532701 95	1GHz~26.5GHz	Aug. 24, 2016	Jan. 05, 2017 ~ Jan. 10, 2017	Aug. 23, 2017	CSE (03CH13-HY)
Spectrum Analyzer	Keysight	N9030A	MY523502 76	3Hz ~ 44GHz	Mar. 21, 2016	Jan. 05, 2017 ~ Jan. 10, 2017	Mar. 20, 2017	CSE (03CH13-HY)
Amplifier	SONOMA	310N	363440	9kHz~1GHz	Nov. 09, 2016	Jan. 05, 2017 ~ Jan. 10, 2017	Nov. 08, 2017	CSE (03CH13-HY)
EMI Test Receiver	R&S	ESU26	100390	20Hz~26.5GHz	Dec. 23, 2016	Jan. 05, 2017 ~ Jan. 10, 2017	Dec. 22, 2017	CSE (03CH13-HY)



5 Uncertainty of Evaluation

Uncertainty of Conducted Emission Measurement (150 kHz ~ 30 MHz)

Measuring Uncertainty for a Level of Confidence of 95% ($U = 2Uc(y)$)	2.7
---	-----

Uncertainty of Radiated Emission Measurement (30 MHz ~ 1000 MHz)

Measuring Uncertainty for a Level of Confidence of 95% ($U = 2Uc(y)$)	5.2
---	-----

Uncertainty of Radiated Emission Measurement (1000 MHz ~ 18000 MHz)

Measuring Uncertainty for a Level of Confidence of 95% ($U = 2Uc(y)$)	5.5
---	-----

Uncertainty of Radiated Emission Measurement (18000 MHz ~ 40000 MHz)

Measuring Uncertainty for a Level of Confidence of 95% ($U = 2Uc(y)$)	5.2
---	-----



Appendix A. Conducted Test Results

Test Engineer:	AC Chang	Temperature:	21~25	°C
Test Date:	2016/12/29	Relative Humidity:	51~54	%

TEST RESULTS DATA
6dB and 99% Occupied Bandwidth

2.4GHz Band								
Mod.	Data Rate	N _{TX}	CH.	Freq. (MHz)	99% Occupied BW (MHz)	6dB BW (MHz)	6dB BW Limit (MHz)	Pass/Fail
11b	1Mbps	1	1	2412	15.65	8.88	0.50	Pass
11b	1Mbps	1	6	2437	16.20	7.88	0.50	Pass
11b	1Mbps	1	11	2462	15.40	9.74	0.50	Pass
11g	6Mbps	1	1	2412	16.25	13.88	0.50	Pass
11g	6Mbps	1	6	2437	16.75	14.62	0.50	Pass
11g	6Mbps	1	11	2462	15.75	10.84	0.50	Pass
HT20	MCS0	1	1	2412	17.20	11.64	0.50	Pass
HT20	MCS0	1	6	2437	17.90	15.14	0.50	Pass
HT20	MCS0	1	11	2462	16.20	13.84	0.50	Pass

TEST RESULTS DATA
Peak Power Table

2.4GHz Band										
Mod.	Data Rate	N _{TX}	CH.	Freq. (MHz)	Peak Conducted Power (dBm)	Conducted Power Limit (dBm)	DG (dBi)	EIRP Power (dBm)	EIRP Power Limit (dBm)	Pass /Fail
11b	1Mbps	1	1	2412	-15.03	30.00	2.27	-12.76	36.00	Pass
11b	1Mbps	1	6	2437	-12.06	30.00	2.27	-9.79	36.00	Pass
11b	1Mbps	1	11	2462	-34.41	30.00	2.27	-32.14	36.00	Pass
11g	6Mbps	1	1	2412	-24.00	30.00	2.27	-21.73	36.00	Pass
11g	6Mbps	1	6	2437	-23.70	30.00	2.27	-21.43	36.00	Pass
11g	6Mbps	1	11	2462	-24.00	30.00	2.27	-21.73	36.00	Pass
HT20	MCS0	1	1	2412	-22.42	30.00	2.27	-20.15	36.00	Pass
HT20	MCS0	1	6	2437	-22.63	30.00	2.27	-20.36	36.00	Pass
HT20	MCS0	1	11	2462	-22.17	30.00	2.27	-19.90	36.00	Pass

TEST RESULTS DATA
Average Power Table
(Reporting Only)

2.4GHz Band						
Mod.	Data Rate	N _{TX}	CH.	Freq. (MHz)	Duty Factor (dB)	Average Conducted Power (dBm)
11b	1Mbps	1	1	2412	0.00	-18.30
11b	1Mbps	1	6	2437	0.00	-14.60
11b	1Mbps	1	11	2462	0.00	-17.30
11g	6Mbps	1	1	2412	0.00	-25.60
11g	6Mbps	1	6	2437	0.00	-25.00
11g	6Mbps	1	11	2462	0.00	-25.60
HT20	MCS0	1	1	2412	0.00	-25.60
HT20	MCS0	1	6	2437	0.00	-25.60
HT20	MCS0	1	11	2462	0.00	-25.60

TEST RESULTS DATA
Peak Power Density

2.4GHz Band								
Mod.	Data Rate	N _{TX}	CH.	Freq. (MHz)	Peak PSD (dBm /3kHz)	DG (dBi)	Peak PSD Limit (dBm /3kHz)	Pass/Fail
11b	1Mbps	1	1	2412	-36.80	2.27	8.00	Pass
11b	1Mbps	1	6	2437	-32.64	2.27	8.00	Pass
11b	1Mbps	1	11	2462	-35.27	2.27	8.00	Pass
11g	6Mbps	1	1	2412	-36.69	2.27	8.00	Pass
11g	6Mbps	1	6	2437	-40.20	2.27	8.00	Pass
11g	6Mbps	1	11	2462	-40.51	2.27	8.00	Pass
HT20	MCS0	1	1	2412	-37.10	2.27	8.00	Pass
HT20	MCS0	1	6	2437	-37.17	2.27	8.00	Pass
HT20	MCS0	1	11	2462	-37.12	2.27	8.00	Pass

Appendix B. AC Conducted Emission Test Results

Test Engineer :	Kai-Chun Chu	Temperature :	23~24°C
		Relative Humidity :	50~51%
Test Voltage :	120Vac / 60Hz	Phase :	Line

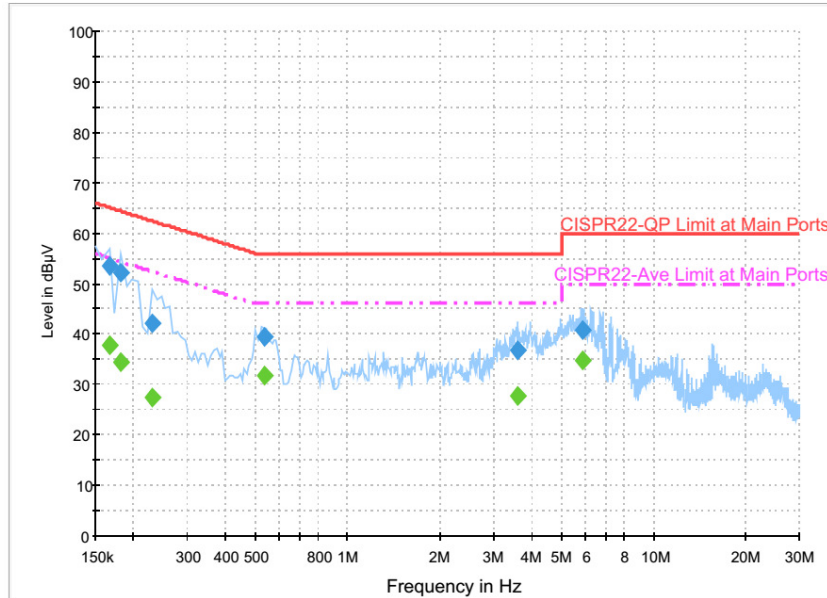

Final Result : Quasi-Peak

Frequency (MHz)	Quasi-Peak (dBµV)	Filter	Line	Corr. (dB)	Margin (dB)	Limit (dBµV)
0.166000	53.4	Off	L1	19.6	11.8	65.2
0.182000	52.1	Off	L1	19.6	12.3	64.4
0.230000	42.3	Off	L1	19.6	20.1	62.4
0.534000	39.3	Off	L1	19.6	16.7	56.0
3.590000	36.9	Off	L1	19.6	19.1	56.0
5.878000	40.8	Off	L1	19.7	19.2	60.0

Final Result : Average

Frequency (MHz)	Average (dBµV)	Filter	Line	Corr. (dB)	Margin (dB)	Limit (dBµV)
0.166000	37.8	Off	L1	19.6	17.4	55.2
0.182000	34.5	Off	L1	19.6	19.9	54.4
0.230000	27.3	Off	L1	19.6	25.1	52.4
0.534000	31.7	Off	L1	19.6	14.3	46.0
3.590000	27.9	Off	L1	19.6	18.1	46.0
5.878000	34.9	Off	L1	19.7	15.1	50.0



Test Engineer :	Kai-Chun Chu	Temperature :	23~24°C
		Relative Humidity :	50~51%
Test Voltage :	120Vac / 60Hz	Phase :	Neutral

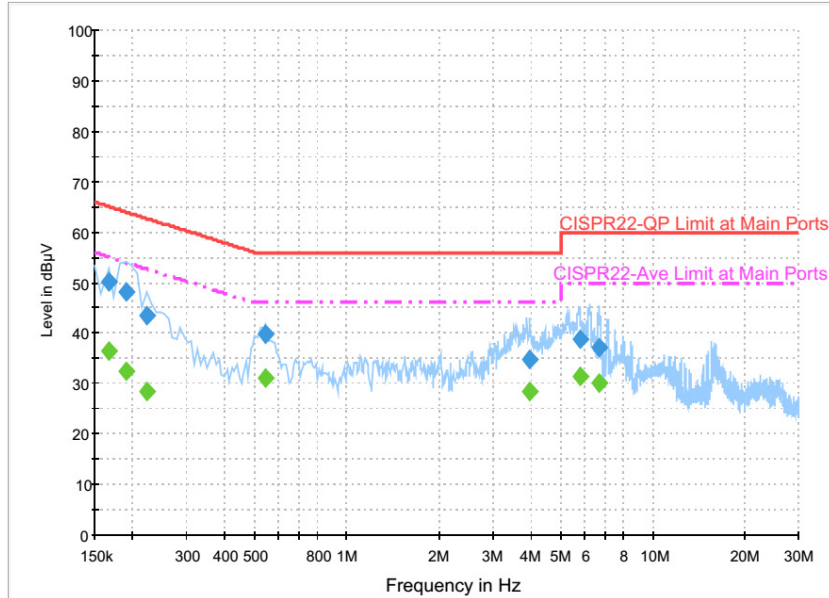

Final Result : Quasi-Peak

Frequency (MHz)	Quasi-Peak (dBµV)	Filter	Line	Corr. (dB)	Margin (dB)	Limit (dBµV)
0.166000	50.1	Off	N	19.6	15.1	65.2
0.190000	48.0	Off	N	19.6	16.0	64.0
0.222000	43.4	Off	N	19.6	19.3	62.7
0.542000	39.8	Off	N	19.6	16.2	56.0
3.950000	34.6	Off	N	19.6	21.4	56.0
5.782000	38.7	Off	N	19.7	21.3	60.0
6.662000	37.1	Off	N	19.7	22.9	60.0

Final Result : Average

Frequency (MHz)	Average (dBµV)	Filter	Line	Corr. (dB)	Margin (dB)	Limit (dBµV)
0.166000	36.5	Off	N	19.6	18.7	55.2
0.190000	32.4	Off	N	19.6	21.6	54.0
0.222000	28.5	Off	N	19.6	24.2	52.7
0.542000	31.0	Off	N	19.6	15.0	46.0
3.950000	28.3	Off	N	19.6	17.7	46.0
5.782000	31.6	Off	N	19.7	18.4	50.0
6.662000	30.2	Off	N	19.7	19.8	50.0



Appendix C. Radiated Spurious Emission

Test Engineer :	Rover Lee	Temperature :	22~24°C
		Relative Humidity :	53~56%

2.4GHz 2400~2483.5MHz

WIFI 802.11b (Band Edge @ 3m)

WIFI	Note	Frequency	Level	Over	Limit	Read	Antenna	Cable	Preamp	Ant	Table	Peak	Pol.	
Ant.				Limit	Line	Level	Factor	Loss	Factor	Pos	Pos	Avg.		
1		(MHz)	(dBμV/m)	(dB)	(dBμV/m)	(dBμV)	(dB/m)	(dB)	(dB)	(cm)	(deg)	(P/A)	(H/V)	
802.11b CH 01 2412MHz		2370.9	53.53	-20.47	74	51.17	27.14	8.82	33.6	357	0	P	H	
		2331.84	46.16	-7.84	54	44.04	26.98	8.75	33.61	357	0	A	H	
	*	2412	91.15	-	-	88.61	27.24	8.89	33.59	357	0	P	H	
	*	2412	85.08	-	-	82.54	27.24	8.89	33.59	357	0	A	H	
													H	
													H	
			2385.915	54.19	-19.81	74	51.71	27.19	8.89	33.6	400	217	P	V
			2390	46.19	-7.81	54	43.7	27.19	8.89	33.59	400	217	A	V
	*		2412	96.54	-	-	94	27.24	8.89	33.59	400	217	P	V
	*		2412	91.8	-	-	89.26	27.24	8.89	33.59	400	217	A	V
													V	
													V	
802.11b CH 06 2437MHz		2368.52	54.26	-19.74	74	51.9	27.14	8.82	33.6	363	0	P	H	
		2379.58	46.47	-7.53	54	44.11	27.14	8.82	33.6	363	0	A	H	
	*	2437	89.35	-	-	86.66	27.34	8.94	33.59	363	0	P	H	
	*	2437	82.66	-	-	79.97	27.34	8.94	33.59	363	0	A	H	
			2493.91	54.39	-19.61	74	51.48	27.5	8.98	33.57	363	0	P	H
			2496.43	46.47	-7.53	54	43.56	27.5	8.98	33.57	363	0	A	H
			2358.44	54.03	-19.97	74	51.72	27.09	8.82	33.6	400	248	P	V
			2378.88	46.08	-7.92	54	43.72	27.14	8.82	33.6	400	248	A	V
	*		2437	99.28	-	-	96.59	27.34	8.94	33.59	400	248	P	V
	*		2437	94.98	-	-	92.29	27.34	8.94	33.59	400	248	A	V
			2498.32	55.37	-18.63	74	52.46	27.5	8.98	33.57	400	248	P	V
			2492.72	46.64	-7.36	54	43.73	27.5	8.98	33.57	400	248	P	V



WIFI Ant. 1	Note	Frequency (MHz)	Level (dBμV/m)	Over Limit (dB)	Limit Line (dBμV/m)	Read Level (dBμV)	Antenna Factor (dB/m)	Cable Loss (dB)	Preamp Factor (dB)	Ant Pos (cm)	Table Pos (deg)	Peak Avg. (P/A)	Pol. (H/V)
802.11b CH 11 2462MHz	*	2462	88.81	-	-	86.01	27.4	8.98	33.58	400	330	P	H
	*	2462	84.05	-	-	81.25	27.4	8.98	33.58	400	330	A	H
		2488.68	54.44	-19.56	74	51.54	27.5	8.98	33.58	400	330	P	H
		2492.28	46.7	-7.3	54	43.79	27.5	8.98	33.57	400	330	A	H
													H
													H
	*	2462	96.35	-	-	93.55	27.4	8.98	33.58	380	244	P	V
	*	2462	90.45	-	-	87.65	27.4	8.98	33.58	380	244	A	V
		2487.6	55.32	-18.68	74	52.42	27.5	8.98	33.58	380	244	P	V
		2486.84	46.73	-7.27	54	43.88	27.45	8.98	33.58	380	244	A	V
													V
													V
	Remark	1. No other spurious found. 2. All results are PASS against Peak and Average limit line.											



2.4GHz 2400~2483.5MHz

WIFI 802.11b (Harmonic @ 3m)

WIFI Ant. 1	Note	Frequency (MHz)	Level (dBμV/m)	Over Limit (dB)	Limit Line (dBμV/m)	Read Level (dBμV)	Antenna Factor (dB/m)	Cable Loss (dB)	Preamp Factor (dB)	Ant Pos (cm)	Table Pos (deg)	Peak Avg. (P/A)	Pol. (H/V)	
802.11b CH 01 2412MHz		4824	32.24	-41.76	74	40.87	31.69	10.77	51.09	100	0	P	H	
													H	
													H	
													H	
			4824	35.71	-38.29	74	44.34	31.69	10.77	51.09	100	0	P	V
														V
														V
802.11b CH 06 2437MHz		4874	32.97	-41.03	74	41.37	31.78	10.88	51.06	100	0	P	H	
		7311	37.6	-36.4	74	38.05	37.27	12.79	50.51	100	0	P	H	
													H	
													H	
			4874	36.41	-37.59	74	44.81	31.78	10.88	51.06	100	0	P	V
			7311	37.92	-36.08	74	38.37	37.27	12.79	50.51	100	0	P	V
														V
802.11b CH 11 2462MHz		4924	32.4	-41.6	74	40.56	31.88	11	51.04	100	0	P	H	
		7386	39.49	-34.51	74	39.74	37.38	12.88	50.51	100	0	P	H	
													H	
													H	
			4924	39.38	-34.62	74	47.54	31.88	11	51.04	100	0	P	V
			7386	38.39	-35.61	74	38.64	37.38	12.88	50.51	100	0	P	V
														V
Remark	1. No other spurious found.													
	2. All results are PASS against Peak and Average limit line.													



2.4GHz 2400~2483.5MHz

WIFI 802.11g (Band Edge @ 3m)

WIFI Ant. 1	Note	Frequency (MHz)	Level (dBμV/m)	Over Limit (dB)	Limit Line (dBμV/m)	Read Level (dBμV)	Antenna Factor (dB/m)	Cable Loss (dB)	Preamp Factor (dB)	Ant Pos (cm)	Table Pos (deg)	Peak Avg. (P/A)	Pol. (H/V)	
802.11g CH 01 2412MHz		2366.175	53.69	-20.31	74	51.38	27.09	8.82	33.6	335	360	P	H	
		2363.865	45.88	-8.12	54	43.57	27.09	8.82	33.6	335	360	A	H	
	*	2412	88.11	-	-	85.57	27.24	8.89	33.59	335	360	P	H	
	*	2412	82.03	-	-	79.49	27.24	8.89	33.59	335	360	A	H	
													H	
														H
			2385.705	54.95	-19.05	74	52.47	27.19	8.89	33.6	400	217	P	V
			2351.58	46.73	-7.27	54	44.42	27.09	8.82	33.6	400	217	A	V
	*		2412	95.26	-	-	92.72	27.24	8.89	33.59	400	217	P	V
	*		2412	90.18	-	-	87.64	27.24	8.89	33.59	400	217	A	V
														V
														V
802.11g CH 06 2437MHz		2373.56	54.48	-19.52	74	52.12	27.14	8.82	33.6	100	38	P	H	
		2335.34	47.06	-6.94	54	44.89	27.03	8.75	33.61	100	38	A	H	
	*	2437	90.19	-	-	87.5	27.34	8.94	33.59	100	38	P	H	
	*	2437	82.12	-	-	79.43	27.34	8.94	33.59	100	38	A	H	
			2494.75	54.81	-19.19	74	51.9	27.5	8.98	33.57	100	38	P	H
			2488.94	46.69	-7.31	54	43.79	27.5	8.98	33.58	100	38	A	H
			2311.26	54.25	-19.75	74	52.18	26.93	8.75	33.61	400	231	P	V
			2375.94	46.4	-7.6	54	44.04	27.14	8.82	33.6	400	231	A	V
	*		2437	100.41	-	-	97.72	27.34	8.94	33.59	400	231	P	V
	*		2437	93.26	-	-	90.57	27.34	8.94	33.59	400	231	A	V
			2483.5	53.65	-20.35	74	50.8	27.45	8.98	33.58	400	231	P	V
			2496.78	46.88	-7.12	54	43.97	27.5	8.98	33.57	400	231	A	V



WIFI Ant. 1	Note	Frequency (MHz)	Level (dBμV/m)	Over Limit (dB)	Limit Line (dBμV/m)	Read Level (dBμV)	Antenna Factor (dB/m)	Cable Loss (dB)	Preamp Factor (dB)	Ant Pos (cm)	Table Pos (deg)	Peak Avg. (P/A)	Pol. (H/V)
802.11g CH 11 2462MHz	*	2462	92.58	-	-	89.78	27.4	8.98	33.58	348	319	P	H
	*	2462	78.73	-	-	75.93	27.4	8.98	33.58	348	319	A	H
		2483.72	57.2	-16.8	74	54.35	27.45	8.98	33.58	348	319	P	H
		2483.76	50.33	-3.67	54	47.48	27.45	8.98	33.58	348	319	A	H
													H
													H
	*	2462	95.82	-	-	93.02	27.4	8.98	33.58	354	304	P	V
	*	2462	88.31	-	-	85.51	27.4	8.98	33.58	354	304	A	V
		2484	54.51	-19.49	74	51.66	27.45	8.98	33.58	354	304	P	V
		2497.72	47.05	-6.95	54	44.14	27.5	8.98	33.57	354	304	A	V
													V
													V
Remark	1. No other spurious found. 2. All results are PASS against Peak and Average limit line.												



2.4GHz 2400~2483.5MHz

WIFI 802.11g (Harmonic @ 3m)

WIFI Ant. 1	Note	Frequency (MHz)	Level (dBμV/m)	Over Limit (dB)	Limit Line (dBμV/m)	Read Level (dBμV)	Antenna Factor (dB/m)	Cable Loss (dB)	Preamp Factor (dB)	Ant Pos (cm)	Table Pos (deg)	Peak Avg. (P/A)	Pol. (H/V)
802.11g CH 01 2412MHz		4824	32.46	-41.54	74	41.09	31.69	10.77	51.09	100	0	P	H
													H
													H
													H
		4824	31.29	-42.71	74	39.92	31.69	10.77	51.09	100	0	P	V
													V
													V
802.11g CH 06 2437MHz		4874	33.04	-40.96	74	41.44	31.78	10.88	51.06	100	0	P	H
		7311	38.03	-35.97	74	38.48	37.27	12.79	50.51	100	0	P	H
													H
													H
		4874	32.04	-41.96	74	40.44	31.78	10.88	51.06	100	0	P	V
		7311	38.02	-35.98	74	38.47	37.27	12.79	50.51	100	0	P	V
													V
802.11g CH 11 2462MHz		4924	32.19	-41.81	74	40.35	31.88	11	51.04	100	0	P	H
		7386	37.68	-36.32	74	37.93	37.38	12.88	50.51	100	0	P	H
													H
													H
		4924	32.76	-41.24	74	40.92	31.88	11	51.04	100	0	P	V
		7386	38.49	-35.51	74	38.74	37.38	12.88	50.51	100	0	P	V
													V
Remark	1. No other spurious found.												
	2. All results are PASS against Peak and Average limit line.												



2.4GHz 2400~2483.5MHz

WIFI 802.11n HT20 (Band Edge @ 3m)

WIFI Ant. 1	Note	Frequency (MHz)	Level (dBμV/m)	Over Limit (dB)	Limit Line (dBμV/m)	Read Level (dBμV)	Antenna Factor (dB/m)	Cable Loss (dB)	Preamp Factor (dB)	Ant Pos (cm)	Table Pos (deg)	Peak Avg. (P/A)	Pol. (H/V)	
802.11n HT20 CH 01 2412MHz		2372.16	53.81	-20.19	74	51.45	27.14	8.82	33.6	386	0	P	H	
		2384.445	46.08	-7.92	54	43.65	27.14	8.89	33.6	386	0	A	H	
	*	2412	87.16	-	-	84.62	27.24	8.89	33.59	386	0	P	H	
	*	2412	79.51	-	-	76.97	27.24	8.89	33.59	386	0	A	H	
													H	
														H
			2385.495	53.84	-20.16	74	51.41	27.14	8.89	33.6	400	220	P	V
			2369.955	46.2	-7.8	54	43.84	27.14	8.82	33.6	400	220	A	V
		*	2412	93.6	-	-	91.06	27.24	8.89	33.59	400	220	P	V
		*	2412	86.66	-	-	84.12	27.24	8.89	33.59	400	220	A	V
													V	
													V	
802.11n HT20 CH 06 2437MHz		2328.62	53.71	-20.29	74	51.59	26.98	8.75	33.61	364	180	P	H	
		2377.34	46.48	-7.52	54	44.12	27.14	8.82	33.6	364	180	A	H	
	*	2437	87.47	-	-	84.78	27.34	8.94	33.59	364	180	P	H	
	*	2437	81.05	-	-	78.36	27.34	8.94	33.59	364	180	A	H	
			2498.88	55.17	-18.83	74	52.26	27.5	8.98	33.57	364	180	P	H
			2497.83	46.7	-7.3	54	43.79	27.5	8.98	33.57	364	180	A	H
			2370.76	53.69	-20.31	74	51.33	27.14	8.82	33.6	400	211	P	V
			2373.14	46.62	-7.38	54	44.26	27.14	8.82	33.6	400	211	A	V
		*	2437	97.12	-	-	94.43	27.34	8.94	33.59	400	211	P	V
		*	2437	90.39	-	-	87.7	27.34	8.94	33.59	400	211	A	V
		2496.15	54.26	-19.74	74	51.35	27.5	8.98	33.57	400	211	P	V	
		2494.96	46.62	-7.38	54	43.71	27.5	8.98	33.57	400	211	A	V	



WIFI Ant. 1	Note	Frequency (MHz)	Level (dBμV/m)	Over Limit (dB)	Limit Line (dBμV/m)	Read Level (dBμV)	Antenna Factor (dB/m)	Cable Loss (dB)	Preamp Factor (dB)	Ant Pos (cm)	Table Pos (deg)	Peak Avg. (P/A)	Pol. (H/V)	
802.11n HT20 CH 11 2462MHz	*	2462	88.2	-	-	85.4	27.4	8.98	33.58	400	360	P	H	
	*	2462	80.78	-	-	77.98	27.4	8.98	33.58	400	360	A	H	
		2485.72	54.2	-19.8	74	51.35	27.45	8.98	33.58	400	360	P	H	
		2484.12	47.4	-6.6	54	44.55	27.45	8.98	33.58	400	360	A	H	
													H	
														H
	*	2462	92.21	-	-	89.41	27.4	8.98	33.58	398	227	P	V	
	*	2462	85.7	-	-	82.9	27.4	8.98	33.58	398	227	A	V	
		2495.84	54.27	-19.73	74	51.36	27.5	8.98	33.57	398	227	P	V	
		2483.92	47.85	-6.15	54	45	27.45	8.98	33.58	398	227	A	V	
														V
														V
Remark	1. No other spurious found. 2. All results are PASS against Peak and Average limit line.													



2.4GHz 2400~2483.5MHz

WIFI 802.11n HT20 (Harmonic @ 3m)

WIFI Ant. 1	Note	Frequency (MHz)	Level (dBμV/m)	Over Limit (dB)	Limit Line (dBμV/m)	Read Level (dBμV)	Antenna Factor (dB/m)	Cable Loss (dB)	Preamp Factor (dB)	Ant Pos (cm)	Table Pos (deg)	Peak Avg. (P/A)	Pol. (H/V)	
802.11n HT20 CH 01 2412MHz		4824	31.42	-42.58	74	40.05	31.69	10.77	51.09	100	0	P	H	
													H	
													H	
													H	
			4824	32.5	-41.5	74	41.13	31.69	10.77	51.09	100	0	P	V
														V
														V
802.11n HT20 CH 06 2437MHz		4874	32.43	-41.57	74	40.83	31.78	10.88	51.06	100	0	P	H	
		7311	38.68	-35.32	74	39.13	37.27	12.79	50.51	100	0	P	H	
													H	
													H	
			4874	32.63	-41.37	74	41.03	31.78	10.88	51.06	100	0	P	V
			7311	37.63	-36.37	74	38.08	37.27	12.79	50.51	100	0	P	V
														V
802.11n HT20 CH 11 2462MHz		4924	32.34	-41.66	74	40.5	31.88	11	51.04	100	0	P	H	
		7386	37.86	-36.14	74	38.11	37.38	12.88	50.51	100	0	P	H	
													H	
													H	
			4924	32.86	-41.14	74	41.02	31.88	11	51.04	100	0	P	V
			7386	37.92	-36.08	74	38.17	37.38	12.88	50.51	100	0	P	V
														V
Remark	1. No other spurious found.													
	2. All results are PASS against Peak and Average limit line.													



Emission below 1GHz

2.4GHz WIFI 802.11g (LF)

WIFI Ant.	Note	Frequency	Level	Over Limit	Limit Line	Read Level	Antenna Factor	Cable Loss	Preamp Factor	Ant Pos	Table Pos	Peak Avg.	Pol.	
1		(MHz)	(dBμV/m)	(dB)	(dBμV/m)	(dBμV)	(dB/m)	(dB)	(dB)	(cm)	(deg)	(P/A)	(H/V)	
2.4GHz 802.11g LF		66.99	36.77	-3.23	40	55.5	12.25	1.51	32.49	315	214	P	H	
		134.22	32.46	-11.04	43.5	45.34	17.96	1.78	32.62	-	-	P	H	
		250.05	36.21	-9.79	46	47.8	18.7	2.34	32.63	-	-	P	H	
		622.7	31.18	-14.82	46	33.91	25.93	3.8	32.46	-	-	P	H	
		673.8	30.88	-15.12	46	32.97	26.44	3.94	32.47	-	-	P	H	
		807.5	32.44	-13.56	46	31.93	28.39	4.26	32.14	-	-	P	H	
														H
														H
														H
														H
														H
														H
			38.37	36.94	-3.06	40	47.28	20.86	1.29	32.49	211	152	P	V
			119.91	27.85	-15.65	43.5	40.93	17.7	1.78	32.56	-	-	P	V
			250.05	30.29	-15.71	46	41.88	18.7	2.34	32.63	-	-	P	V
			472.2	32.13	-13.87	46	37.57	23.65	3.28	32.37	-	-	P	V
			537.3	32.24	-13.76	46	36.65	24.62	3.38	32.41	-	-	P	V
			805.4	32.9	-13.1	46	32.43	28.36	4.26	32.15	-	-	P	V
														V
														V
													V	
													V	
													V	
													V	
Remark	1. No other spurious found. 2. All results are PASS against limit line.													



Note symbol

*	Fundamental Frequency which can be ignored. However, the level of any unwanted emissions shall not exceed the level of the fundamental frequency.
!	Test result is over limit line.
P/A	Peak or Average
H/V	Horizontal or Vertical



A calculation example for radiated spurious emission is shown as below:

WIFI	Note	Frequency	Level	Over	Limit	Read	Antenna	Cable	Preamp	Ant	Table	Peak	Pol.
Ant.				Limit	Line	Level	Factor	Loss	Factor	Pos	Pos	Avg.	
1		(MHz)	(dBμV/m)	(dB)	(dBμV/m)	(dBμV)	(dB/m)	(dB)	(dB)	(cm)	(deg)	(P/A)	(H/V)
802.11b		2390	55.45	-18.55	74	54.51	32.22	4.58	35.86	103	308	P	H
CH 01													
2412MHz		2390	43.54	-10.46	54	42.6	32.22	4.58	35.86	103	308	A	H

- Level(dBμV/m) =
Antenna Factor(dB/m) + Cable Loss(dB) + Read Level(dBμV) - Preamp Factor(dB)
- Over Limit(dB) = Level(dBμV/m) – Limit Line(dBμV/m)

For Peak Limit @ 2390MHz:

- Level(dBμV/m)
= Antenna Factor(dB/m) + Cable Loss(dB) + Read Level(dBμV) - Preamp Factor(dB)
= 32.22(dB/m) + 4.58(dB) + 54.51(dBμV) – 35.86 (dB)
= 55.45 (dBμV/m)
- Over Limit(dB)
= Level(dBμV/m) – Limit Line(dBμV/m)
= 55.45(dBμV/m) – 74(dBμV/m)
= -18.55(dB)

For Average Limit @ 2390MHz:

- Level(dBμV/m)
= Antenna Factor(dB/m) + Cable Loss(dB) + Read Level(dBμV) - Preamp Factor(dB)
= 32.22(dB/m) + 4.58(dB) + 42.6(dBμV) – 35.86 (dB)
= 43.54 (dBμV/m)
- Over Limit(dB)
= Level(dBμV/m) – Limit Line(dBμV/m)
= 43.54(dBμV/m) – 54(dBμV/m)
= -10.46(dB)

Both peak and average measured complies with the limit line, so test result is “PASS”.



Appendix D. Radiated Spurious Emission Plots

Test Engineer :	Rover Lee	Temperature :	22~24°C
		Relative Humidity :	53~56%

Note symbol

-L	Low channel location
-R	High channel location



2.4GHz 2400~2483.5MHz

WIFI 802.11b (Band Edge @ 3m)

WIFI	2.4GHz 2400~2483.5MHz Band Edge @ 3m	
ANT	802.11b CH01 2412MHz	
1	Horizontal	Fundamental
Peak	<p>Date: 2016-11-29</p> <p>Site : 03CH11-HY Condition : PEAK_BE_74 3m HORN 9120D-HF HORIZONTAL RBW:1000.000KHz VBW:3000.000KHz SWT:Auto Detector : Peak Project : 6O1109</p>	<p>Date: 2016-11-29</p> <p>Site : 03CH11-HY Condition : PEAK_74 3m HORN 9120D-HF HORIZONTAL RBW:1000.000KHz VBW:3000.000KHz SWT:Auto Detector : Peak Project : 6O1109</p>
Avg.	<p>Date: 2016-11-29</p> <p>Site : 03CH11-HY Condition : AV6_BE_54 3m HORN 9120D-HF HORIZONTAL RBW:1000.000KHz VBW:10.000KHz SWT:Auto Detector : Peak Project : 6O1109</p>	<p>Date: 2016-11-29</p> <p>Site : 03CH11-HY Condition : AV6_54 3m HORN 9120D-HF HORIZONTAL RBW:1000.000KHz VBW:10.000KHz SWT:Auto Detector : Peak Project : 6O1109</p>

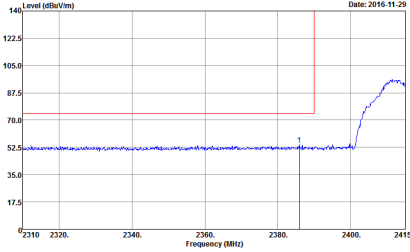
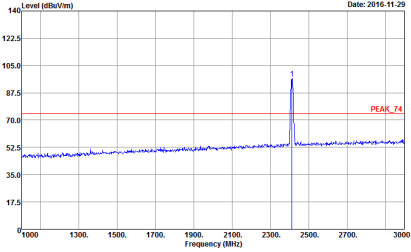
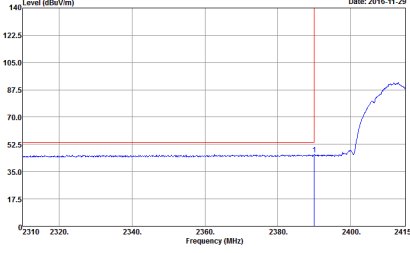
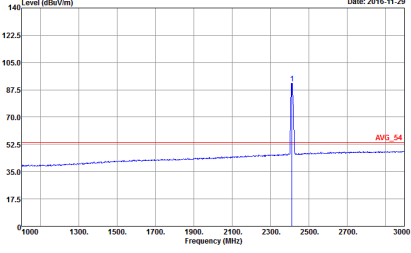

WIFI	2.4GHz 2400~2483.5MHz Band Edge @ 3m	
ANT	802.11b CH01 2412MHz	
1	<p style="text-align: center;">Vertical</p>  <p>Site : 03CH11-HY Condition : PEAK_BE_74 3m HORN 9120D-HF VERTICAL Detector : Peak Project : 6O1109</p>	<p style="text-align: center;">Fundamental</p>  <p>Site : 03CH11-HY Condition : PEAK_74 3m HORN 9120D-HF VERTICAL Detector : Peak Project : 6O1109</p>
Peak	 <p>Site : 03CH11-HY Condition : AV6_BE_54 3m HORN 9120D-HF VERTICAL Detector : Peak Project : 6O1109</p>	 <p>Site : 03CH11-HY Condition : AV6_54 3m HORN 9120D-HF VERTICAL Detector : Peak Project : 6O1109</p>
Avg.		

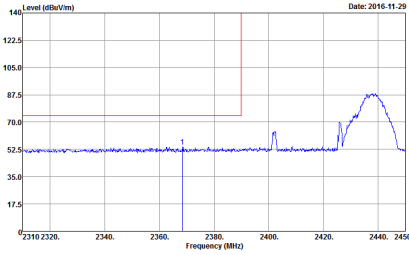
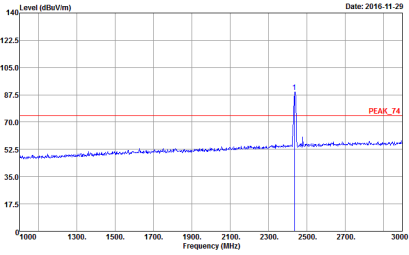
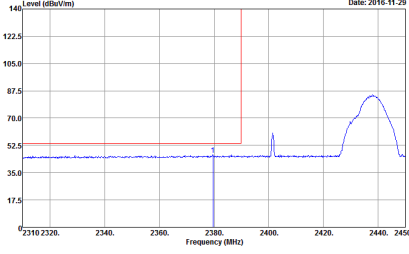
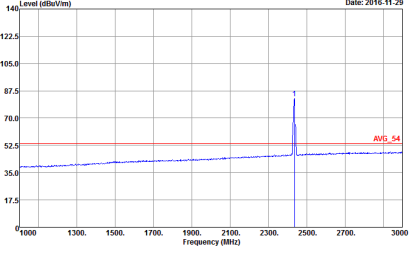

WIFI	2.4GHz 2400~2483.5MHz Band Edge @ 3m	
ANT	802.11b CH06 2437MHz - L	
1	<p style="text-align: center;">Horizontal</p>  <p>Site : 03CH11-HY Condition : PEAK_BE_74 3m HORN 9120D-HF HORIZONTAL RBW:1000.000KHz VBW:3000.000KHz SWT:Auto Detector : Peak Project : 601109</p>	<p style="text-align: center;">Fundamental</p>  <p>Site : 03CH11-HY Condition : PEAK_74 3m HORN 9120D-HF HORIZONTAL RBW:1000.000KHz VBW:3000.000KHz SWT:Auto Detector : Peak Project : 601109</p>
Peak	 <p>Site : 03CH11-HY Condition : AV6_BE_54 3m HORN 9120D-HF HORIZONTAL RBW:1000.000KHz VBW:10.000KHz SWT:Auto Detector : Peak Project : 601109</p>	 <p>Site : 03CH11-HY Condition : AV6_54 3m HORN 9120D-HF HORIZONTAL RBW:1000.000KHz VBW:10.000KHz SWT:Auto Detector : Peak Project : 601109</p>
Avg.		

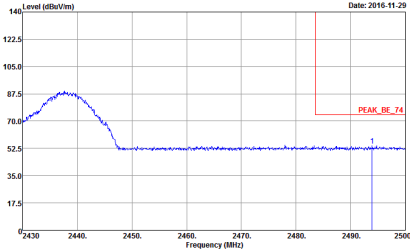
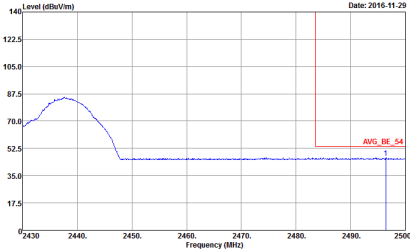

WIFI	2.4GHz 2400~2483.5MHz Band Edge @ 3m	
ANT	802.11b CH06 2437MHz - R	
1	Horizontal	Fundamental
<p>Peak</p>	 <p> Site : 03CH11-HY Condition : PEAK_BE_74 3m HORN 9120D-HF HORIZONTAL RBW:1000.000KHz VBW:3000.000KHz SWT:Auto Detector : Peak Project : 601109 </p>	<p>Left blank</p>
<p>Avg.</p>	 <p> Site : 03CH11-HY Condition : AVG_BE_54 3m HORN 9120D-HF HORIZONTAL RBW:1000.000KHz VBW:10.000KHz SWT:Auto Detector : Peak Project : 601109 </p>	<p>Left blank</p>

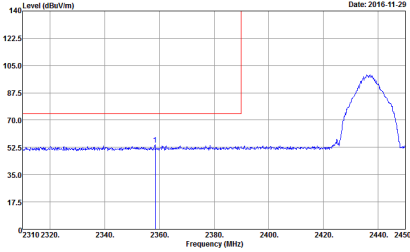
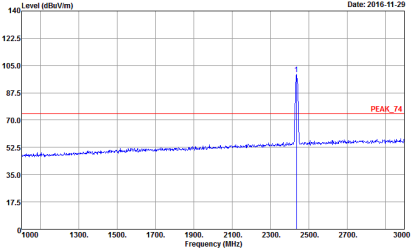
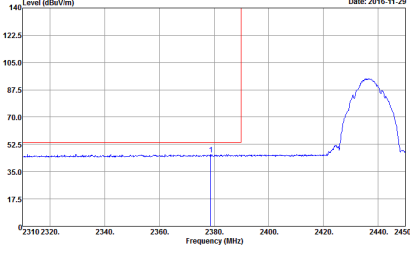
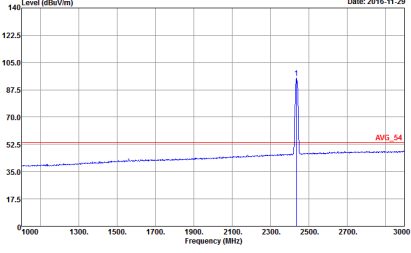

WIFI	2.4GHz 2400~2483.5MHz Band Edge @ 3m	
ANT	802.11b CH06 2437MHz - L	
1	<p style="text-align: center;">Vertical</p>  <p>Site : 03CH11-HY Condition : PEAK_BE_74 3m HORN 9120D-HF VERTICAL RBW:1000.000KHz VBW:3000.000KHz SWT:Auto Detector : Peak Project : 6O1109</p>	<p style="text-align: center;">Fundamental</p>  <p>Site : 03CH11-HY Condition : PEAK_74 3m HORN 9120D-HF VERTICAL RBW:1000.000KHz VBW:3000.000KHz SWT:Auto Detector : Peak Project : 6O1109</p>
Peak	 <p>Site : 03CH11-HY Condition : AV6_BE_54 3m HORN 9120D-HF VERTICAL RBW:1000.000KHz VBW:10.000KHz SWT:Auto Detector : Peak Project : 6O1109</p>	 <p>Site : 03CH11-HY Condition : AV6_54 3m HORN 9120D-HF VERTICAL RBW:1000.000KHz VBW:10.000KHz SWT:Auto Detector : Peak Project : 6O1109</p>
Avg.		

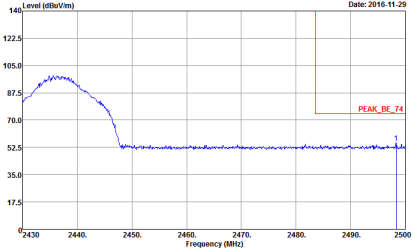
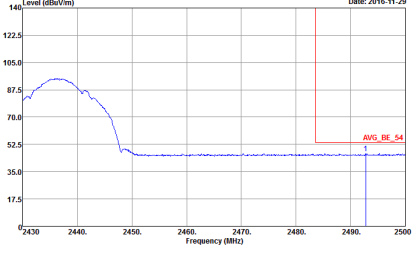

WIFI	2.4GHz 2400~2483.5MHz Band Edge @ 3m	
ANT	802.11b CH06 2437MHz - R	
<p>1</p> <p>Vertical</p> <p>Peak</p>	 <p>Date: 2016-11-29</p> <p>Site : 03CHI1-HY Condition : PEAK_BE_74 3m HORN 9120D-HF VERTICAL RBW:1000.000KHz VBW:3000.000KHz SWT:Auto Detector : Peak Project : 6O1109</p>	<p>Fundamental</p> <p>Left blank</p>
<p>Avg.</p>	 <p>Date: 2016-11-29</p> <p>Site : 03CHI1-HY Condition : AVG_BE_54 3m HORN 9120D-HF VERTICAL RBW:1000.000KHz VBW:10.000KHz SWT:Auto Detector : Peak Project : 6O1109</p>	<p>Left blank</p>

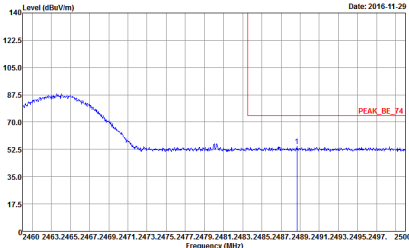
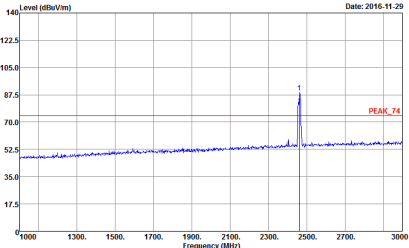
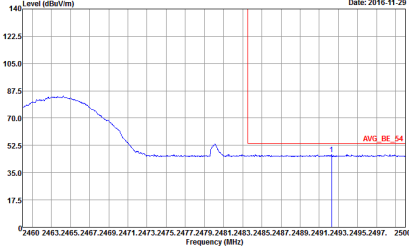
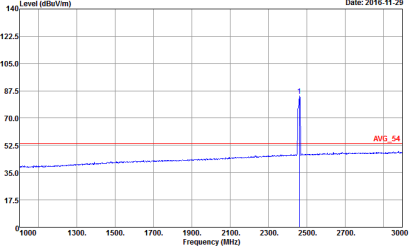

WIFI	2.4GHz 2400~2483.5MHz Band Edge @ 3m	
ANT	802.11b CH11 2462MHz	
1	<p style="text-align: center;">Horizontal</p>  <p>Site : 03CH11-HY Condition : PEAK_BE_74 3m HORN 9120D-HF HORIZONTAL RBW:1000.000KHz VBW:3000.000KHz SWT:Auto Detector : Peak Project : 601109</p>	<p style="text-align: center;">Fundamental</p>  <p>Site : 03CH11-HY Condition : PEAK_74 3m HORN 9120D-HF HORIZONTAL RBW:1000.000KHz VBW:3000.000KHz SWT:Auto Detector : Peak Project : 601109</p>
Avg.	 <p>Site : 03CH11-HY Condition : AVG_BE_54 3m HORN 9120D-HF HORIZONTAL RBW:1000.000KHz VBW:10.000KHz SWT:Auto Detector : Peak Project : 601109</p>	 <p>Site : 03CH11-HY Condition : AVG_54 3m HORN 9120D-HF HORIZONTAL RBW:1000.000KHz VBW:10.000KHz SWT:Auto Detector : Peak Project : 601109</p>

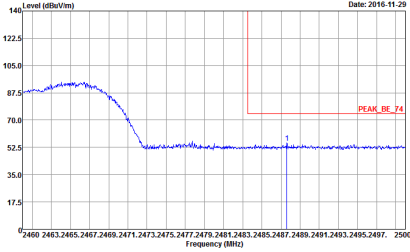
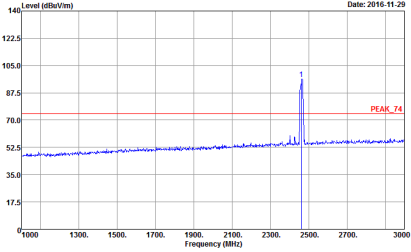
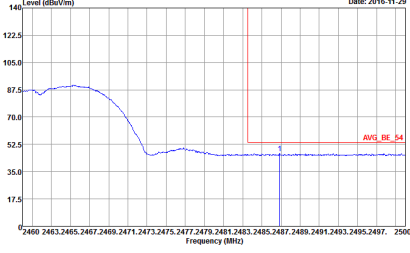
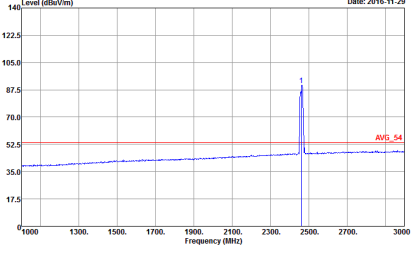

WIFI	2.4GHz 2400~2483.5MHz Band Edge @ 3m	
ANT	802.11b CH11 2462MHz	
1	<p style="text-align: center;">Vertical</p>  <p>Level (dBuV/m) vs Frequency (MHz) plot showing a peak at 2462 MHz. The y-axis ranges from 0 to 140 dBuV/m, and the x-axis ranges from 2460 to 2500 MHz. A red horizontal line indicates the peak level at approximately 75 dBuV/m.</p> <p>Site : 03CH11-HY Condition : PEAK_BE_74 3m HORN 9120D-HF VERTICAL RBW:1000.000KHz VBW:3000.000KHz SWT:Auto Detector : Peak Project : 6O1109</p>	<p style="text-align: center;">Fundamental</p>  <p>Level (dBuV/m) vs Frequency (MHz) plot showing a sharp peak at 2462 MHz. The y-axis ranges from 0 to 140 dBuV/m, and the x-axis ranges from 1000 to 3000 MHz. A red horizontal line indicates the peak level at approximately 75 dBuV/m.</p> <p>Site : 03CH11-HY Condition : PEAK_74 3m HORN 9120D-HF VERTICAL RBW:1000.000KHz VBW:3000.000KHz SWT:Auto Detector : Peak Project : 6O1109</p>
Avg.	 <p>Level (dBuV/m) vs Frequency (MHz) plot showing the average level. The y-axis ranges from 0 to 140 dBuV/m, and the x-axis ranges from 2460 to 2500 MHz. A red horizontal line indicates the average level at approximately 55 dBuV/m.</p> <p>Site : 03CH11-HY Condition : AV6_BE_54 3m HORN 9120D-HF VERTICAL RBW:1000.000KHz VBW:10.000KHz SWT:Auto Detector : Peak Project : 6O1109</p>	 <p>Level (dBuV/m) vs Frequency (MHz) plot showing the average level. The y-axis ranges from 0 to 140 dBuV/m, and the x-axis ranges from 1000 to 3000 MHz. A red horizontal line indicates the average level at approximately 55 dBuV/m.</p> <p>Site : 03CH11-HY Condition : AV6_54 3m HORN 9120D-HF VERTICAL RBW:1000.000KHz VBW:10.000KHz SWT:Auto Detector : Peak Project : 6O1109</p>



2.4GHz 2400~2483.5MHz

WIFI 802.11g (Band Edge @ 3m)

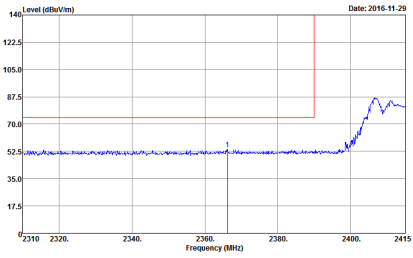
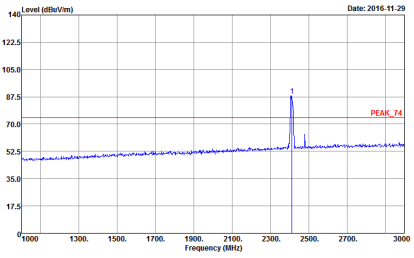
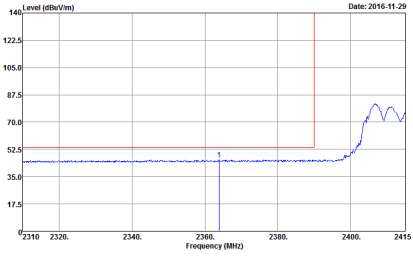
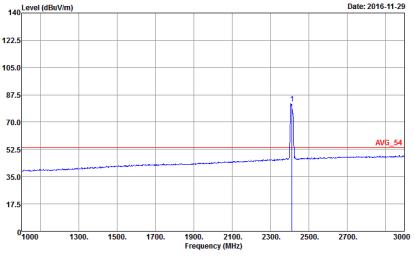
WIFI	2.4GHz 2400~2483.5MHz Band Edge @ 3m	
ANT	802.11g CH01 2412MHz	
1	<p style="text-align: center;">Horizontal</p>  <p>Site : 03CH11-HY Condition : PEAK_BE_74 3m HORN 9120D-HF HORIZONTAL RBW:1000.000KHz VBW:3000.000KHz SWT:Auto Detector : Peak Project : 6O1109</p>	<p style="text-align: center;">Fundamental</p>  <p>Site : 03CH11-HY Condition : PEAK_74 3m HORN 9120D-HF HORIZONTAL RBW:1000.000KHz VBW:3000.000KHz SWT:Auto Detector : Peak Project : 6O1109</p>
Avg.	 <p>Site : 03CH11-HY Condition : AV6_BE_54 3m HORN 9120D-HF HORIZONTAL RBW:1000.000KHz VBW:10.000KHz SWT:Auto Detector : Peak Project : 6O1109</p>	 <p>Site : 03CH11-HY Condition : AV6_54 3m HORN 9120D-HF HORIZONTAL RBW:1000.000KHz VBW:10.000KHz SWT:Auto Detector : Peak Project : 6O1109</p>

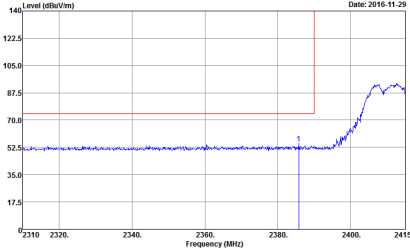
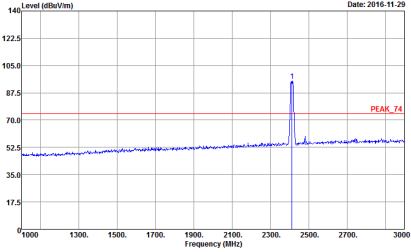
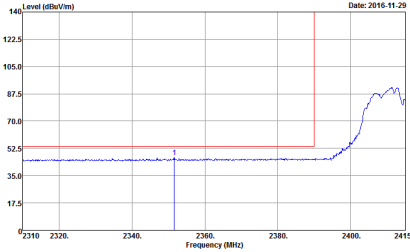
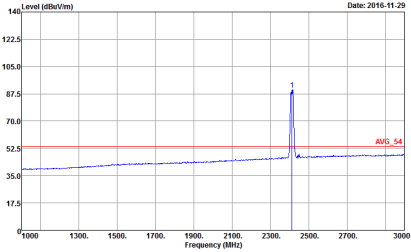

WIFI	2.4GHz 2400~2483.5MHz Band Edge @ 3m	
ANT	802.11g CH01 2412MHz	
1	<p style="text-align: center;">Vertical</p>  <p>Site : 03CH11-HY Condition : PEAK_BE_74 3m HORN 9120D-HF VERTICAL Detector : Peak Project : 6O1109</p>	<p style="text-align: center;">Fundamental</p>  <p>Site : 03CH11-HY Condition : PEAK_74 3m HORN 9120D-HF VERTICAL Detector : Peak Project : 6O1109</p>
Peak	 <p>Site : 03CH11-HY Condition : AV6_BE_54 3m HORN 9120D-HF VERTICAL Detector : Peak Project : 6O1109</p>	 <p>Site : 03CH11-HY Condition : AV6_54 3m HORN 9120D-HF VERTICAL Detector : Peak Project : 6O1109</p>
Avg.		

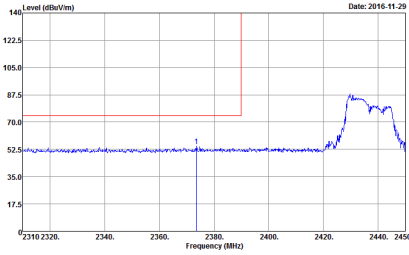
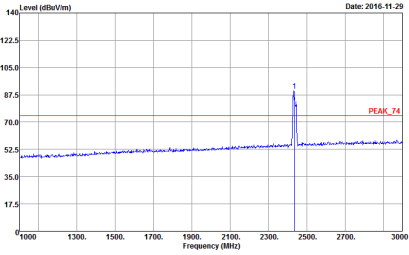
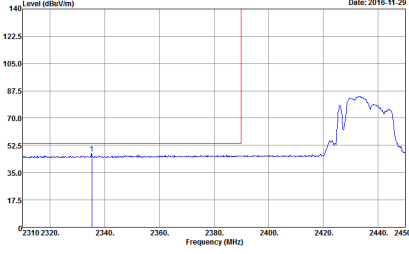
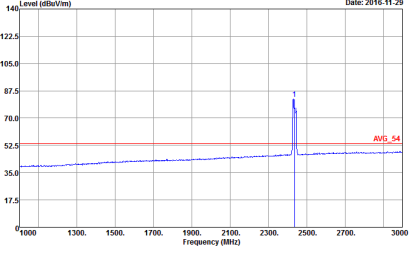

WIFI	2.4GHz 2400~2483.5MHz Band Edge @ 3m	
ANT	802.11g CH06 2437MHz - L	
1	<p style="text-align: center;">Horizontal</p>  <p>Site : 03CH11-HY Condition : PEAK_BE_74 3m HORN 9120D-HF HORIZONTAL RBW:1000.000KHz VBW:3000.000KHz SWT:Auto Detector : Peak Project : 601109</p>	<p style="text-align: center;">Fundamental</p>  <p>Site : 03CH11-HY Condition : PEAK_74 3m HORN 9120D-HF HORIZONTAL RBW:1000.000KHz VBW:3000.000KHz SWT:Auto Detector : Peak Project : 601109</p>
Avg.	 <p>Site : 03CH11-HY Condition : AV6_BE_54 3m HORN 9120D-HF HORIZONTAL RBW:1000.000KHz VBW:10.000KHz SWT:Auto Detector : Peak Project : 601109</p>	 <p>Site : 03CH11-HY Condition : AV6_54 3m HORN 9120D-HF HORIZONTAL RBW:1000.000KHz VBW:10.000KHz SWT:Auto Detector : Peak Project : 601109</p>



WIFI	2.4GHz 2400~2483.5MHz Band Edge @ 3m	
ANT	802.11g CH06 2437MHz - R	
1	Horizontal	Fundamental
Peak	<p>Site : 03CH11-HY Condition : PEAK_BE_74 3m HORN 9120D-HF HORIZONTAL RBW:1000.000KHz VBW:3000.000KHz SWT:Auto Detector : Peak Project : 601109</p>	Left blank
Avg.	<p>Site : 03CH11-HY Condition : AVG_BE_54 3m HORN 9120D-HF HORIZONTAL RBW:1000.000KHz VBW:10.000KHz SWT:Auto Detector : Peak Project : 601109</p>	Left blank

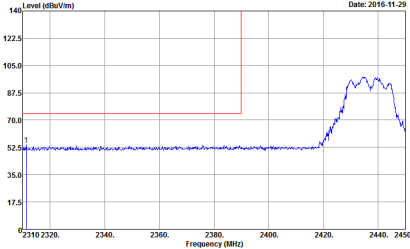
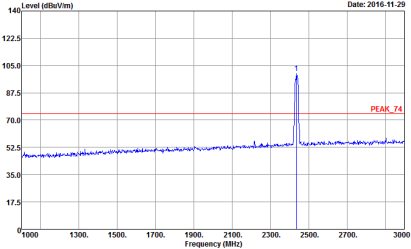
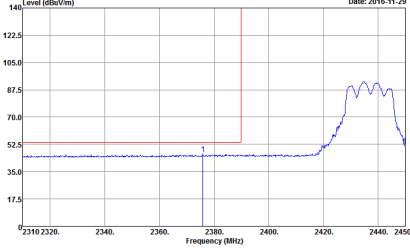
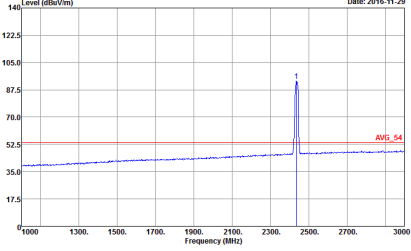

WIFI	2.4GHz 2400~2483.5MHz Band Edge @ 3m	
ANT	802.11g CH06 2437MHz - L	
<p style="text-align: center;">1</p>	<p style="text-align: center;">Vertical</p>  <p>Site : 03CH11-HY Condition : PEAK_BE_74 3m HORN 9120D-HF VERTICAL RBW:1000.000KHz VBW:3000.000KHz SWT:Auto Detector : Peak Project : 601109</p>	<p style="text-align: center;">Fundamental</p>  <p>Site : 03CH11-HY Condition : PEAK_74 3m HORN 9120D-HF VERTICAL RBW:1000.000KHz VBW:3000.000KHz SWT:Auto Detector : Peak Project : 601109</p>
<p style="text-align: center;">Avg.</p>	 <p>Site : 03CH11-HY Condition : AV6_BE_54 3m HORN 9120D-HF VERTICAL RBW:1000.000KHz VBW:10000KHz SWT:Auto Detector : Peak Project : 601109</p>	 <p>Site : 03CH11-HY Condition : AV6_54 3m HORN 9120D-HF VERTICAL RBW:1000.000KHz VBW:10000KHz SWT:Auto Detector : Peak Project : 601109</p>

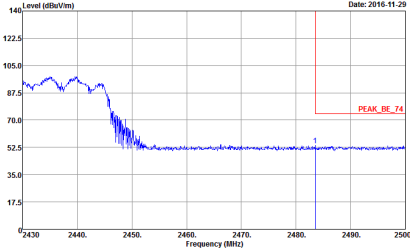
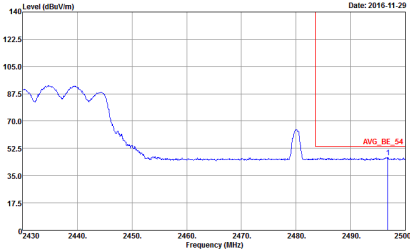

WIFI	2.4GHz 2400~2483.5MHz Band Edge @ 3m	
ANT	802.11g CH06 2437MHz - R	
1	Vertical	Fundamental
<p>Peak</p>	 <p>Date: 2016-11-29</p> <p>Site : 03CHI1-HY Condition : PEAK_BE_74 3m HORN 9120D-HF VERTICAL RBW:1000.000KHz VBW:3000.000KHz SWT:Auto Detector : Peak Project : 601109</p>	<p>Left Blank</p>
<p>Avg.</p>	 <p>Date: 2016-11-29</p> <p>Site : 03CHI1-HY Condition : AVG_BE_54 3m HORN 9120D-HF VERTICAL RBW:1000.000KHz VBW:10.000KHz SWT:Auto Detector : Peak Project : 601109</p>	<p>Left Blank</p>

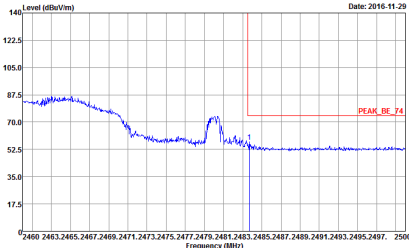
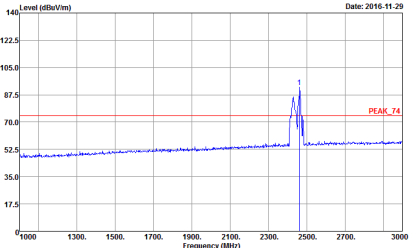
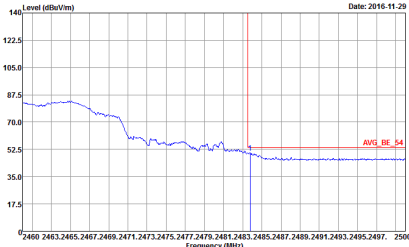
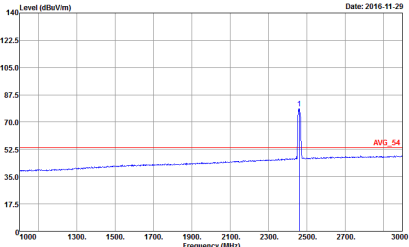

WIFI	2.4GHz 2400~2483.5MHz Band Edge @ 3m	
ANT	802.11g CH11 2462MHz	
1	<p style="text-align: center;">Horizontal</p>  <p>Site : 03CH11-HY Condition : PEAK_BE_74 3m HORN 9120D-HF HORIZONTAL RBW:1000.000KHz VBW:3000.000KHz SWT:Auto Detector : Peak Project : 601109</p>	<p style="text-align: center;">Fundamental</p>  <p>Site : 03CH11-HY Condition : PEAK_74 3m HORN 9120D-HF HORIZONTAL RBW:1000.000KHz VBW:3000.000KHz SWT:Auto Detector : Peak Project : 601109</p>
Avg.	 <p>Site : 03CH11-HY Condition : AVG_BE_54 3m HORN 9120D-HF HORIZONTAL RBW:1000.000KHz VBW:10.000KHz SWT:Auto Detector : Peak Project : 601109</p>	 <p>Site : 03CH11-HY Condition : AVG_54 3m HORN 9120D-HF HORIZONTAL RBW:1000.000KHz VBW:10.000KHz SWT:Auto Detector : Peak Project : 601109</p>

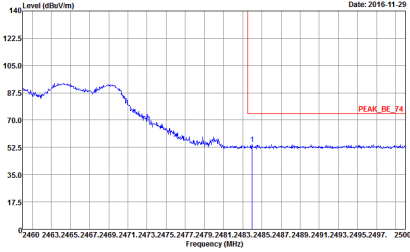
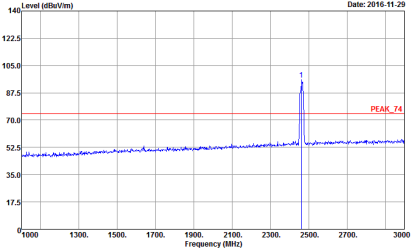
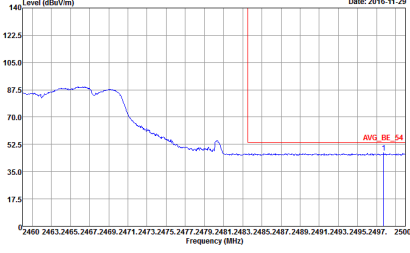
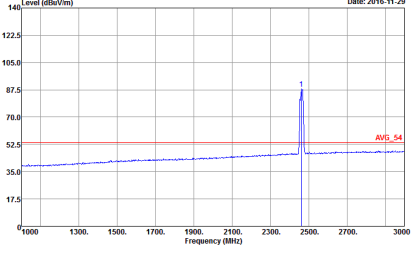

WIFI	2.4GHz 2400~2483.5MHz Band Edge @ 3m	
ANT	802.11g CH11 2462MHz	
1	<p style="text-align: center;">Vertical</p>  <p>Level (dBuV/m) vs Frequency (MHz) plot showing a peak at 2462 MHz. The y-axis ranges from 0 to 140 dBuV/m, and the x-axis ranges from 2460 to 2500 MHz. A red horizontal line indicates the peak level at approximately 75 dBuV/m.</p> <p>Site : 03CH11-HY Condition : PEAK_BE_74 3m HORN 9120D-HF VERTICAL RBW:1000.000KHz VBW:3000.000KHz SWT:Auto Detector : Peak Project : 6O1109</p>	<p style="text-align: center;">Fundamental</p>  <p>Level (dBuV/m) vs Frequency (MHz) plot showing a sharp peak at 2462 MHz. The y-axis ranges from 0 to 140 dBuV/m, and the x-axis ranges from 1000 to 3000 MHz. A red horizontal line indicates the peak level at approximately 75 dBuV/m.</p> <p>Site : 03CH11-HY Condition : PEAK_74 3m HORN 9120D-HF VERTICAL RBW:1000.000KHz VBW:3000.000KHz SWT:Auto Detector : Peak Project : 6O1109</p>
Avg.	 <p>Level (dBuV/m) vs Frequency (MHz) plot showing the average spectrum. The y-axis ranges from 0 to 140 dBuV/m, and the x-axis ranges from 2460 to 2500 MHz. A red horizontal line indicates the average level at approximately 55 dBuV/m.</p> <p>Site : 03CH11-HY Condition : AV6_BE_54 3m HORN 9120D-HF VERTICAL RBW:1000.000KHz VBW:10.000KHz SWT:Auto Detector : Peak Project : 6O1109</p>	 <p>Level (dBuV/m) vs Frequency (MHz) plot showing the average spectrum. The y-axis ranges from 0 to 140 dBuV/m, and the x-axis ranges from 1000 to 3000 MHz. A red horizontal line indicates the average level at approximately 55 dBuV/m.</p> <p>Site : 03CH11-HY Condition : AV6_54 3m HORN 9120D-HF VERTICAL RBW:1000.000KHz VBW:10.000KHz SWT:Auto Detector : Peak Project : 6O1109</p>





2.4GHz 2400~2483.5MHz

WIFI 802.11n HT20 (Band Edge @ 3m)

WIFI	2.4GHz 2400~2483.5MHz Band Edge @ 3m	
ANT	802.11n HT20 CH01 2412MHz	
1	Horizontal	Fundamental
Peak	<p>Site : 03CH11-HY Condition : PEAK_BE_74 3m HORN 9120D-HF HORIZONTAL RBW:1000.000KHz VBW:3000.000KHz SWT:Auto Detector : Peak Project : 6O1109</p>	<p>Site : 03CH11-HY Condition : PEAK_74 3m HORN 9120D-HF HORIZONTAL RBW:1000.000KHz VBW:3000.000KHz SWT:Auto Detector : Peak Project : 6O1109</p>
Avg.	<p>Site : 03CH11-HY Condition : AV6_BE_54 3m HORN 9120D-HF HORIZONTAL RBW:1000.000KHz VBW:10.000KHz SWT:Auto Detector : Peak Project : 6O1109</p>	<p>Site : 03CH11-HY Condition : AV6_54 3m HORN 9120D-HF HORIZONTAL RBW:1000.000KHz VBW:10.000KHz SWT:Auto Detector : Peak Project : 6O1109</p>

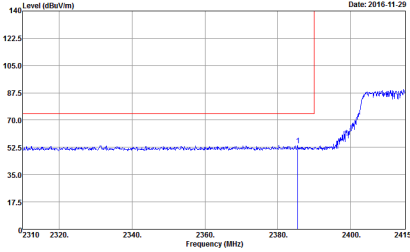
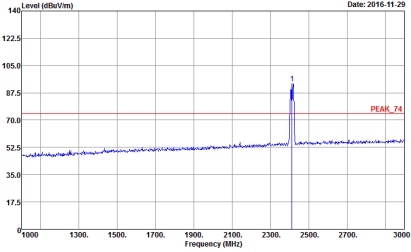
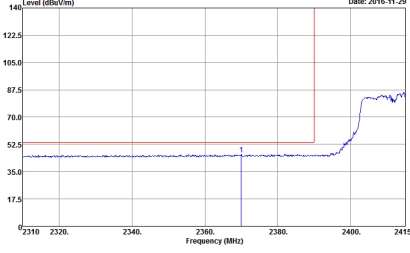
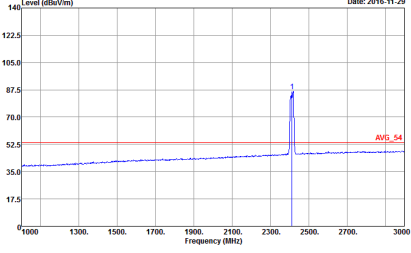
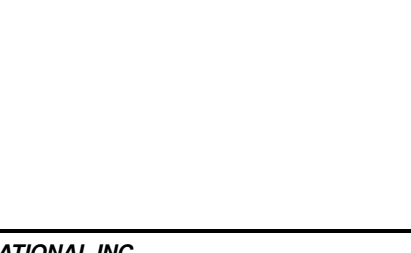

WIFI	2.4GHz 2400~2483.5MHz Band Edge @ 3m	
ANT	802.11n HT20 CH01 2412MHz	
1	<p style="text-align: center;">Vertical</p>  <p>Site : 03CH11-HY Condition : PEAK_BE_74 3m HORN 9120D-HF VERTICAL Detector : Peak Project : 601109</p>	<p style="text-align: center;">Fundamental</p>  <p>Site : 03CH11-HY Condition : PEAK_74 3m HORN 9120D-HF VERTICAL Detector : Peak Project : 601109</p>
Peak	 <p>Site : 03CH11-HY Condition : AV6_BE_54 3m HORN 9120D-HF VERTICAL Detector : Peak Project : 601109</p>	 <p>Site : 03CH11-HY Condition : AV6_54 3m HORN 9120D-HF VERTICAL Detector : Peak Project : 601109</p>
Avg.	 <p>Site : 03CH11-HY Condition : AV6_BE_54 3m HORN 9120D-HF VERTICAL Detector : Peak Project : 601109</p>	 <p>Site : 03CH11-HY Condition : AV6_54 3m HORN 9120D-HF VERTICAL Detector : Peak Project : 601109</p>

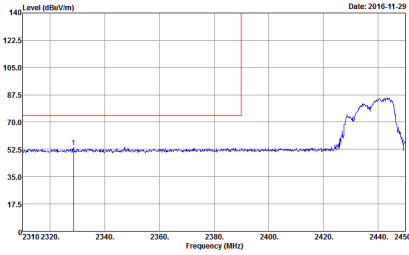
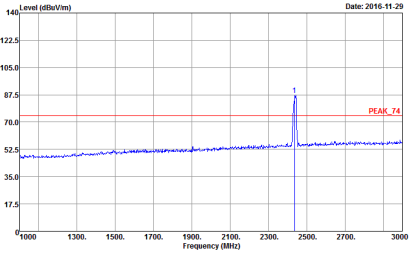
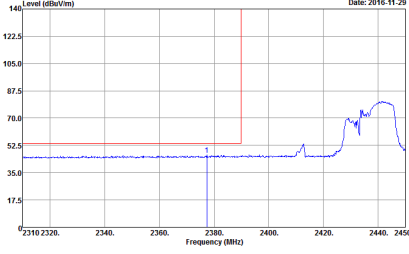
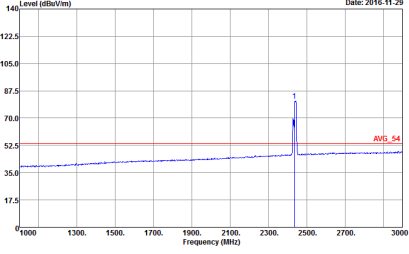

WIFI	2.4GHz 2400~2483.5MHz Band Edge @ 3m	
ANT	802.11n HT20 CH06 2437MHz - L	
1	<p style="text-align: center;">Horizontal</p>  <p>Site : 03CH11-HY Condition : PEAK_BE_74 3m HORN 9120D-HF HORIZONTAL RBW:1000.000KHz VBW:3000.000KHz SWT:Auto Detector : Peak Project : 601109</p>	<p style="text-align: center;">Fundamental</p>  <p>Site : 03CH11-HY Condition : PEAK_74 3m HORN 9120D-HF HORIZONTAL RBW:1000.000KHz VBW:3000.000KHz SWT:Auto Detector : Peak Project : 601109</p>
Avg.	 <p>Site : 03CH11-HY Condition : AV6_BE_54 3m HORN 9120D-HF HORIZONTAL RBW:1000.000KHz VBW:10.000KHz SWT:Auto Detector : Peak Project : 601109</p>	 <p>Site : 03CH11-HY Condition : AV6_54 3m HORN 9120D-HF HORIZONTAL RBW:1000.000KHz VBW:10.000KHz SWT:Auto Detector : Peak Project : 601109</p>

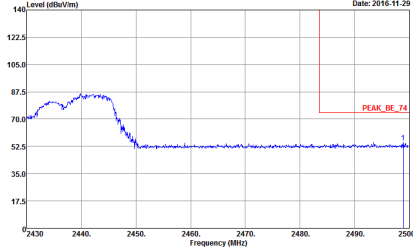
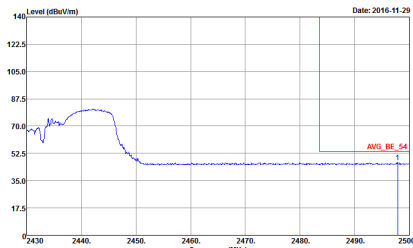

WIFI	2.4GHz 2400~2483.5MHz Band Edge @ 3m	
ANT	802.11n HT20 CH06 2437MHz - R	
1	Horizontal	Fundamental
Peak	 <p> Site : 03CH11-HY Condition : PEAK_BE_74 3m HORN 9120D-HF HORIZONTAL RBW:1000.000KHz VBW:3000.000KHz SWT:Auto Detector : Peak Project : 601109 </p>	Left blank
Avg.	 <p> Site : 03CH11-HY Condition : AV6_BE_54 3m HORN 9120D-HF HORIZONTAL RBW:1000.000KHz VBW:10.000KHz SWT:Auto Detector : Peak Project : 601109 </p>	Left blank

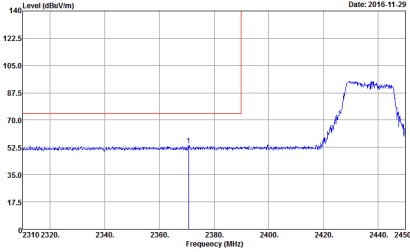
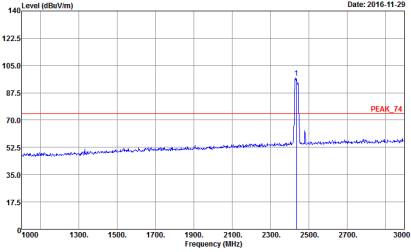
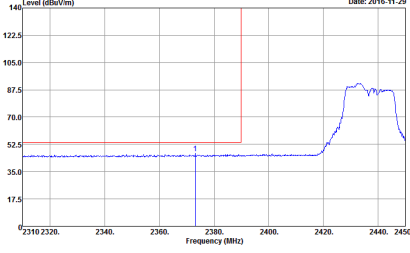
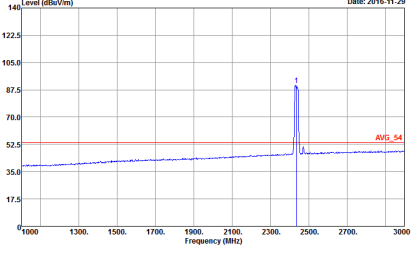

WIFI	2.4GHz 2400~2483.5MHz Band Edge @ 3m	
ANT	802.11n HT20 CH06 2437MHz - L	
1	<p style="text-align: center;">Vertical</p>  <p>Site : 03CH11-HY Condition : PEAK_BE_74 3m HORN 9120D-HF VERTICAL Detector : Peak Project : 6O1109</p>	<p style="text-align: center;">Fundamental</p>  <p>Site : 03CH11-HY Condition : PEAK_74 3m HORN 9120D-HF VERTICAL Detector : Peak Project : 6O1109</p>
Peak	 <p>Site : 03CH11-HY Condition : AV6_BE_54 3m HORN 9120D-HF VERTICAL Detector : Peak Project : 6O1109</p>	 <p>Site : 03CH11-HY Condition : AV6_54 3m HORN 9120D-HF VERTICAL Detector : Peak Project : 6O1109</p>
Avg.		

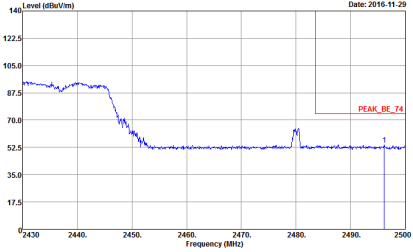
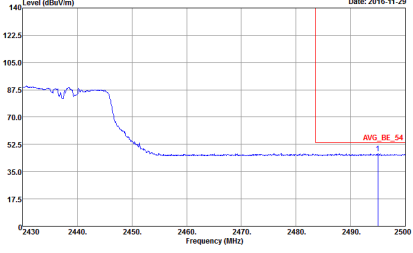

WIFI	2.4GHz 2400~2483.5MHz Band Edge @ 3m	
ANT	802.11n HT20 CH06 2437MHz - R	
<p>1</p> <p>Vertical</p> <p>Peak</p>	 <p>Date: 2016-11-29</p> <p>Site : 03CHI1-HY Condition : PEAK_BE_74 3m HORN 9120D-HF VERTICAL RBW:1000.000KHz VBW:3000.000KHz SWT:Auto Detector : Peak Project : 6O1109</p>	<p>Fundamental</p> <p>Left Blank</p>
<p>Avg.</p>	 <p>Date: 2016-11-29</p> <p>Site : 03CHI1-HY Condition : AVG_BE_54 3m HORN 9120D-HF VERTICAL RBW:1000.000KHz VBW:10.000KHz SWT:Auto Detector : Peak Project : 6O1109</p>	<p>Left Blank</p>

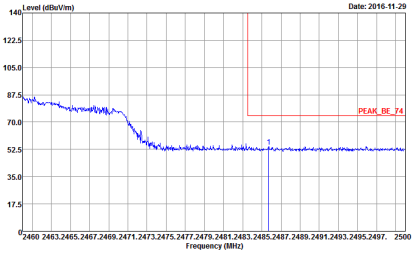
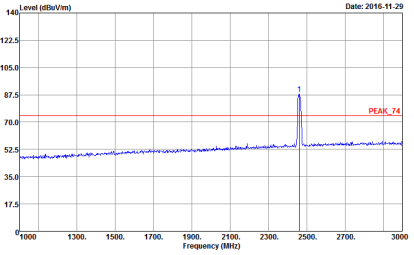
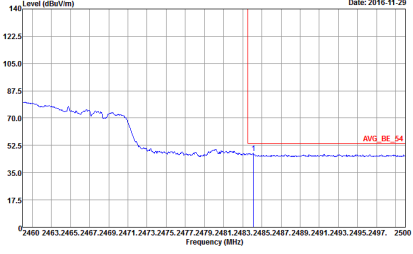
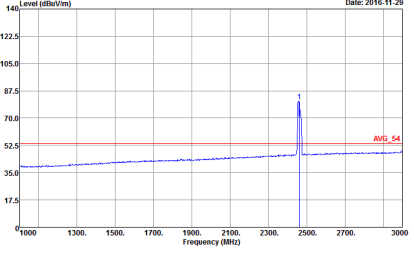

WIFI	2.4GHz 2400~2483.5MHz Band Edge @ 3m	
ANT	802.11n HT20 CH11 2462MHz	
1	<p style="text-align: center;">Horizontal</p>  <p>Site : 03CH11-HY Condition : PEAK_BE_74 3m HORN 9120D-HF HORIZONTAL RBW:1000.000KHz VBW:3000.000KHz SWT:Auto Detector : Peak Project : 601109</p>	<p style="text-align: center;">Fundamental</p>  <p>Site : 03CH11-HY Condition : PEAK_74 3m HORN 9120D-HF HORIZONTAL RBW:1000.000KHz VBW:3000.000KHz SWT:Auto Detector : Peak Project : 601109</p>
Avg.	 <p>Site : 03CH11-HY Condition : AVG_BE_54 3m HORN 9120D-HF HORIZONTAL RBW:1000.000KHz VBW:10.000KHz SWT:Auto Detector : Peak Project : 601109</p>	 <p>Site : 03CH11-HY Condition : AVG_54 3m HORN 9120D-HF HORIZONTAL RBW:1000.000KHz VBW:10.000KHz SWT:Auto Detector : Peak Project : 601109</p>

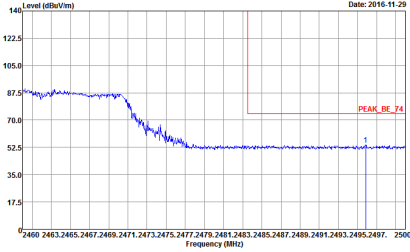
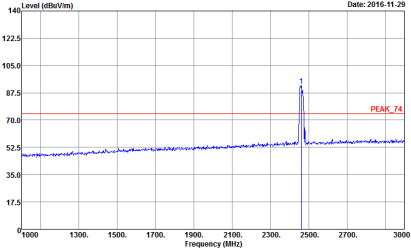
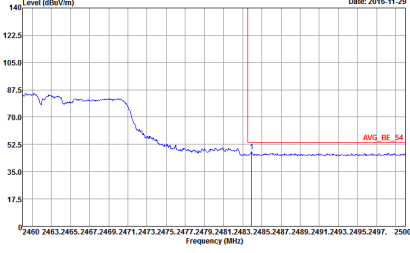
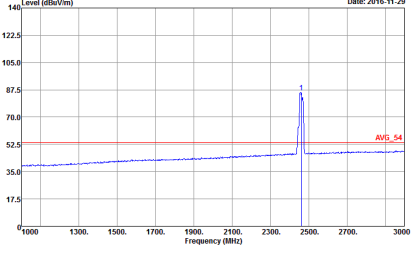

WIFI	2.4GHz 2400~2483.5MHz Fundamental @ 3m	
ANT	802.11n HT20 CH11 2462MHz	
1	<p style="text-align: center;">Vertical</p>  <p>Level (dBuV/m) vs Frequency (MHz) plot showing a peak at 2462 MHz. The y-axis ranges from 0 to 140 dBuV/m, and the x-axis ranges from 2460 to 2500 MHz. A red horizontal line indicates the peak level at approximately 87.5 dBuV/m, labeled 'PEAK_BE_74'.</p> <p>Site : 03CH11-HY Condition : PEAK_BE_74 3m HORN 9120D-HF VERTICAL RBW:1000.000KHz VBW:3000.000KHz SWT:Auto Detector : Peak Project : 601109</p>	<p style="text-align: center;">Fundamental</p>  <p>Level (dBuV/m) vs Frequency (MHz) plot showing a peak at 2462 MHz. The y-axis ranges from 0 to 140 dBuV/m, and the x-axis ranges from 1000 to 3000 MHz. A red horizontal line indicates the peak level at approximately 87.5 dBuV/m, labeled 'PEAK_74'.</p> <p>Site : 03CH11-HY Condition : PEAK_74 3m HORN 9120D-HF VERTICAL RBW:1000.000KHz VBW:3000.000KHz SWT:Auto Detector : Peak Project : 601109</p>
Avg.	 <p>Level (dBuV/m) vs Frequency (MHz) plot showing the average level. The y-axis ranges from 0 to 140 dBuV/m, and the x-axis ranges from 2460 to 2500 MHz. A red horizontal line indicates the average level at approximately 52.5 dBuV/m, labeled 'AVG_BE_54'.</p> <p>Site : 03CH11-HY Condition : AVG_BE_54 3m HORN 9120D-HF VERTICAL RBW:1000.000KHz VBW:10.000KHz SWT:Auto Detector : Peak Project : 601109</p>	 <p>Level (dBuV/m) vs Frequency (MHz) plot showing the average level. The y-axis ranges from 0 to 140 dBuV/m, and the x-axis ranges from 1000 to 3000 MHz. A red horizontal line indicates the average level at approximately 52.5 dBuV/m, labeled 'AVG_54'.</p> <p>Site : 03CH11-HY Condition : AVG_54 3m HORN 9120D-HF VERTICAL RBW:1000.000KHz VBW:10.000KHz SWT:Auto Detector : Peak Project : 601109</p>



2.4GHz 2400~2483.5MHz

WIFI 802.11b (Harmonic @ 3m)

WIFI	2.4GHz 2400~2483.5MHz Harmonic @ 3m	
ANT	802.11b CH01 2412MHz	
1	Horizontal	Vertical
<p>Peak</p> <p>Avg.</p>	<p>Site : 03CH11-4Y Condition : PEAK_74 3m 9170 SHF HORM_150809 HORIZONTAL Detector : Peak Project : 6O1109</p>	<p>Site : 03CH11-4Y Condition : PEAK_74 3m 9170 SHF HORM_150809 VERTICAL Detector : Peak Project : 6O1109</p>

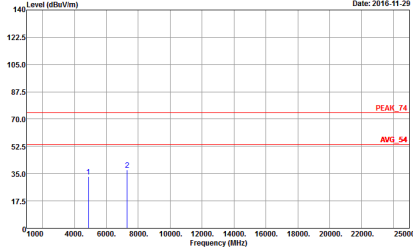
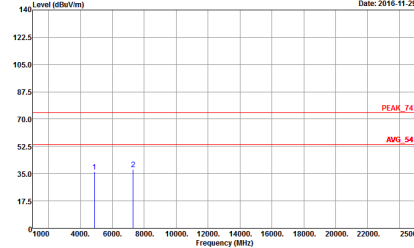

WIFI	2.4GHz 2400~2483.5MHz Harmonic @ 3m	
ANT	802.11b CH06 2437MHz	
1	Horizontal	Vertical
Peak Avg.	 <p>Site : 08CH11-HY Condition : PEAK_74 3m 9170 SHF HORM_150809 HORIZONTAL Detector : Peak Project : 6O1109</p>	 <p>Site : 08CH11-HY Condition : PEAK_74 3m 9170 SHF HORM_150809 VERTICAL Detector : Peak Project : 6O1109</p>

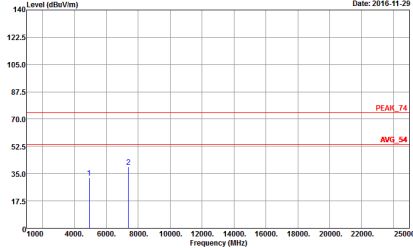
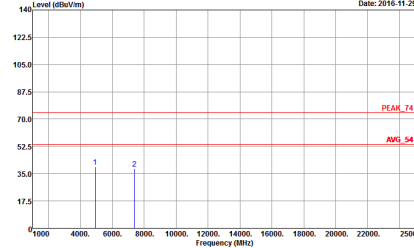

WIFI	2.4GHz 2400~2483.5MHz Harmonic @ 3m	
ANT	802.11b CH11 2462MHz	
1	Horizontal	Vertical
Peak Avg.	 <p>Site : 08CH11-HY Condition : PEAK_74 3m 9170 SHF HORM_150809 HORIZONTAL Detector : Peak Project : 6O1109</p>	 <p>Site : 08CH11-HY Condition : PEAK_74 3m 9170 SHF HORM_150809 VERTICAL Detector : Peak Project : 6O1109</p>



2.4GHz 2400~2483.5MHz

WIFI 802.11g (Harmonic @ 3m)

WIFI	2.4GHz 2400~2483.5MHz Harmonic @ 3m	
ANT	802.11g CH01 2412MHz	
1	Horizontal	Vertical
Peak Avg.	<p>Site : 03CH11-HY Condition : PEAK_74 3m 9170 SHF HORM_150809 HORIZONTAL Detector : Peak Project : 6O1109</p>	<p>Site : 03CH11-HY Condition : PEAK_74 3m 9170 SHF HORM_150809 VERTICAL Detector : Peak Project : 6O1109</p>

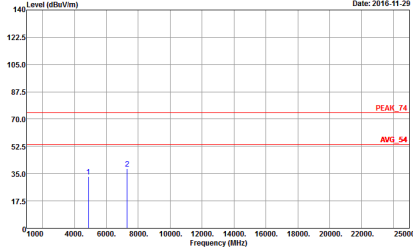
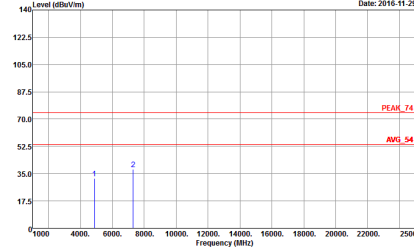

WIFI	2.4GHz 2400~2483.5MHz Harmonic @ 3m	
ANT	802.11g CH06 2437MHz	
1	Horizontal	Vertical
<p>Peak</p> <p>Avg.</p>	 <p>Site : 08CH11-HY Condition : PEAK_74 3m 9170 SHF HORM_150809 HORIZONTAL Detector : Peak Project : 6O1109</p>	 <p>Site : 08CH11-HY Condition : PEAK_74 3m 9170 SHF HORM_150809 VERTICAL Detector : Peak Project : 6O1109</p>

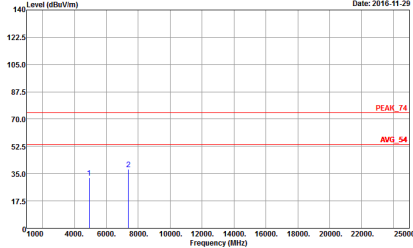
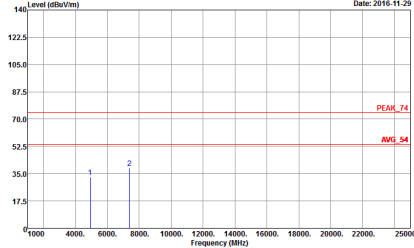

WIFI	2.4GHz 2400~2483.5MHz Harmonic @ 3m	
ANT	802.11g CH11 2462MHz	
1	Horizontal	Vertical
<p>Peak</p> <p>Avg.</p>	 <p>Site : 08CH11-HY Condition : PEAK_74 3m 9170 SHF HORM_150809 HORIZONTAL Detector : Peak Project : 6O1109</p>	 <p>Site : 08CH11-HY Condition : PEAK_74 3m 9170 SHF HORM_150809 VERTICAL Detector : Peak Project : 6O1109</p>



2.4GHz 2400~2483.5MHz

WIFI 802.11n HT20 (Harmonic @ 3m)

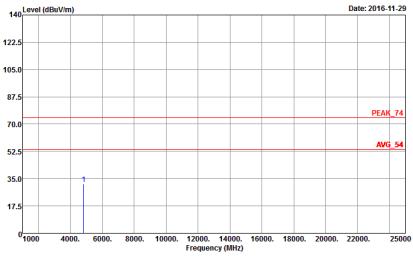
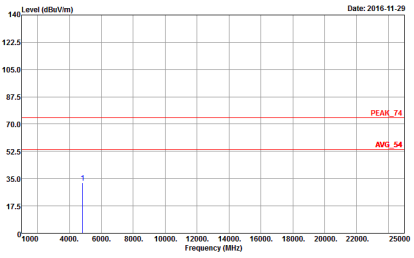
WIFI	2.4GHz 2400~2483.5MHz Harmonic @ 3m	
ANT	802.11n HT20 CH01 2412MHz	
1	Horizontal	Vertical
Peak Avg.	 <p>Site : 03CH11-HY Condition : PEAK_74 3m 9170 SHF HORM_150809 HORIZONTAL Detector : Peak Project : 6O1109</p>	 <p>Site : 03CH11-HY Condition : PEAK_74 3m 9170 SHF HORM_150809 VERTICAL Detector : Peak Project : 6O1109</p>

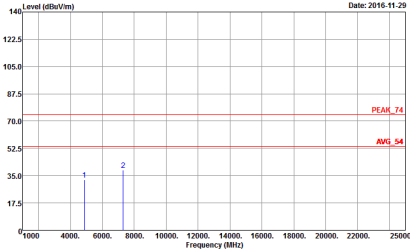
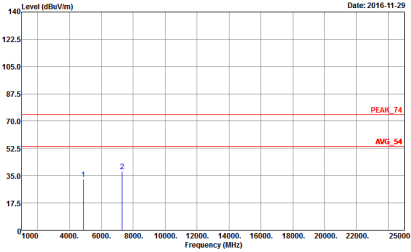

WIFI	2.4GHz 2400~2483.5MHz Harmonic @ 3m	
ANT	802.11n HT20 CH06 2437MHz	
1	Horizontal	Vertical
Peak Avg.	 <p>Site : 08CH11-HY Condition : PEAK_74 3m 9170 SHF HORM_150809 HORIZONTAL Detector : Peak Project : 6O1109</p>	 <p>Site : 08CH11-HY Condition : PEAK_74 3m 9170 SHF HORM_150809 VERTICAL Detector : Peak Project : 6O1109</p>

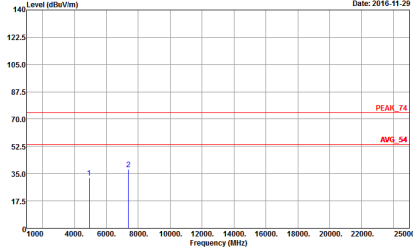
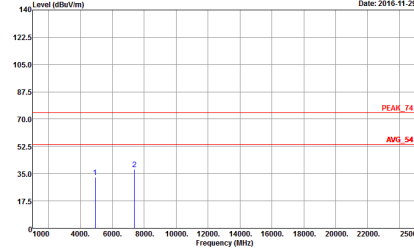

WIFI	2.4GHz 2400~2483.5MHz Harmonic @ 3m	
ANT	802.11n HT20 CH11 2462MHz	
1	Horizontal	Vertical
<p>Peak Avg.</p>	 <p>Site : 08CH11-HY Condition : PEAK_74 3m 9170 SHF HORM_150809 HORIZONTAL Detector : Peak Project : 6O1109</p>	 <p>Site : 08CH11-HY Condition : PEAK_74 3m 9170 SHF HORM_150809 VERTICAL Detector : Peak Project : 6O1109</p>



Emission below 1GHz

2.4GHz WIFI 802.11g (LF)

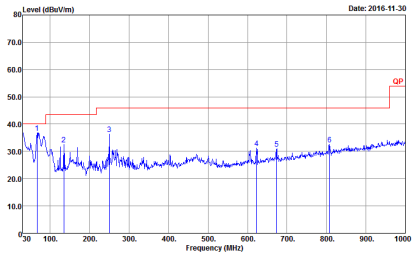
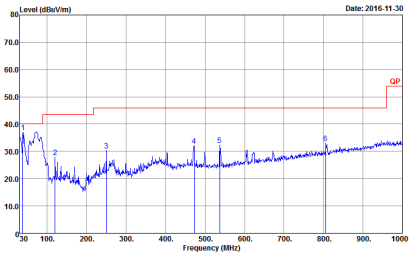
WIFI	2.4GHz 2400~2483.5MHz	
ANT	802.11g LF	
1	Horizontal	Vertical
<p>QP / Peak</p>	 <p>Site : 03CH11-HY Condition : QP 3m BI-LOG 6111D-LF_ETC HORIZONTAL Detector : Peak Project : 6O1109</p>	 <p>Site : 03CH11-HY Condition : QP 3m BI-LOG 6111D-LF_ETC VERTICAL Detector : Peak Project : 6O1109</p>



Appendix E. Conducted Spurious Emission (Restricted Band)

Test Engineer :	Rover Lee	Temperature :	22~24°C
		Relative Humidity :	53~56%

2.4GHz 2400~2483.5MHz

WIFI 802.11b (Band Edge @ 3m)

WIFI	Note	Frequency	Level	Over	Limit	Read	Antenna	Cable	Preamp	Aux	Peak	
Ant.		(MHz)	(dBm)	(dB)	(dBm)	(dBm)	(dBi)	(dB)	(dB)	(dB)	Avg.	
1											(P/A)	
802.11b CH 01 2412MHz		2328.9	-55.4	-34.2	-21.2	-60.61	2.27	2.94			P	
		2385.33	-65.39	-24.19	-41.2	-70.64	2.27	2.98			A	
	*	2412	-24.22	-	-	-29.5	2.27	3.01			P	
	*	2412	-27.97	-	-	-33.25	2.27	3.01			A	
		2487.54	-54.31	-33.11	-21.2	-59.63	2.27	3.05			P	
		2487.68	-65.77	-24.57	-41.2	-71.09	2.27	3.05			A	
802.11b CH 06 2437MHz		2380.605	-55.23	-34.03	-21.2	-60.48	2.27	2.98			P	
		2388.705	-66	-24.8	-41.2	-71.25	2.27	2.98			A	
	*	2437	-19.52	-	-	-24.81	2.27	3.02			P	
	*	2437	-23.66	-	-	-28.95	2.27	3.02			A	
		2483.48	-54.6	-33.4	-21.2	-59.92	2.27	3.05			P	
		2488.24	-65.66	-24.46	-41.2	-70.98	2.27	3.05			A	



WIFI Ant. 1	Note	Frequency (MHz)	Level (dBm)	Over Limit (dB)	Limit Line (dBm)	Read Level (dBm)	Antenna Gain (dBi)	Cable Loss (dB)	Preamp Gain (dB)	Aux Gain (dB)	Peak Avg. (P/A)	
802.11b CH 11 2462MHz		2357.79	-54.56	-33.36	-21.2	-59.8	2.27	2.97			P	
		2383.44	-66.21	-25.01	-41.2	-71.46	2.27	2.98			A	
	*	2462	-19.9	-	-	-25.2	2.27	3.03			P	
	*	2462	-36.4	-	-	-41.7	2.27	3.03			A	
		2484.32	-55.04	-33.84	-21.2	-60.36	2.27	3.05			P	
		2487.68	-65.27	-24.07	-41.2	-70.59	2.27	3.05			A	
Remark	1. No other spurious found. 2. All results are PASS against Peak and Average limit line.											



2.4GHz 2400~2483.5MHz

WIFI 802.11b (Harmonic @ 3m)

WIFI Ant. 1	Note	Frequency (MHz)	Level (dBm)	Over Limit (dB)	Limit Line (dBm)	Read Level (dBm)	Antenna Gain (dBi)	Cable Loss (dB)	Preamp Gain (dB)	Aux Gain (dB)	Peak Avg. (P/A)	
802.11b CH 01 2412MHz		4824	-96.8	-75.6	-21.2	-73.33	2.27	4.41	30.15		P	
802.11b CH 06 2437MHz		4874	-95.85	-74.65	-21.2	-72.43	2.27	4.44	30.13		P	
		7311	-96.69	-75.49	-21.2	-73.56	2.27	5.87	31.27		P	
802.11b CH 11 2462MHz		4924	-95.61	-74.41	-21.2	-72.24	2.27	4.47	30.11		P	
		7386	-95.27	-74.07	-21.2	-72.12	2.27	5.89	31.31		P	
Remark	1. No other spurious found. 2. All results are PASS against Peak and Average limit line.											



**2.4GHz 2400~2483.5MHz
WIFI 802.11g (Band Edge @ 3m)**

WIFI Ant. 1	Note	Frequency (MHz)	Level (dBm)	Over Limit (dB)	Limit Line (dBm)	Read Level (dBm)	Antenna Gain (dBi)	Cable Loss (dB)	Preamp Gain (dB)	Aux Gain (dB)	Peak Avg. (P/A)	
802.11g CH 01 2412MHz		2389.92	-44.25	-23.05	-21.2	-49.5	2.27	2.98			P	
		2390	-56.46	-15.26	-41.2	-61.71	2.27	2.98			A	
	*	2412	-21.39	-	-	-26.67	2.27	3.01			P	
	*	2412	-27.76	-	-	-33.04	2.27	3.01			A	
		2492.79	-55.13	-33.93	-21.2	-60.45	2.27	3.05			P	
		2499.86	-65.91	-24.71	-41.2	-71.23	2.27	3.05			A	
802.11g CH 06 2437MHz		2378.58	-53.42	-32.22	-21.2	-58.67	2.27	2.98			P	
		2342.67	-66.45	-25.25	-41.2	-71.67	2.27	2.95			A	
	*	2437	-14.97	-	-	-20.26	2.27	3.02			P	
	*	2437	-21.7	-	-	-26.99	2.27	3.02			A	
		2492.93	-54.55	-33.35	-21.2	-59.87	2.27	3.05			P	
		2497.34	-65.68	-24.48	-41.2	-71	2.27	3.05			A	



WIFI Ant. 1	Note	Frequency (MHz)	Level (dBm)	Over Limit (dB)	Limit Line (dBm)	Read Level (dBm)	Antenna Gain (dBi)	Cable Loss (dB)	Preamp Gain (dB)	Aux Gain (dB)	Peak Avg. (P/A)	
802.11g CH 11 2462MHz		2375.07	-54.42	-33.22	-21.2	-59.66	2.27	2.97			P	
		2356.71	-66.01	-24.81	-41.2	-71.23	2.27	2.95			A	
	*	2462	-13.09	-	-	-18.39	2.27	3.03			P	
	*	2462	-25.99	-	-	-31.29	2.27	3.03			A	
		2483.83	-41.18	-19.98	-21.2	-46.5	2.27	3.05			P	
		2483.48	-54.75	-13.55	-41.2	-60.07	2.27	3.05			A	
Remark	1. No other spurious found. 2. All results are PASS against Peak and Average limit line.											



**2.4GHz 2400~2483.5MHz
WIFI 802.11g (Harmonic @ 3m)**

WIFI Ant. 1	Note	Frequency (MHz)	Level (dBm)	Over Limit (dB)	Limit Line (dBm)	Read Level (dBm)	Antenna Gain (dBi)	Cable Loss (dB)	Preamp Gain (dB)	Aux Gain (dB)	Peak Avg. (P/A)	
802.11g CH 01 2412MHz		4824	-96.32	-75.12	-21.2	-72.85	2.27	4.41	30.15		P	
802.11g CH 06 2437MHz		4874	-90.9	-69.7	-21.2	-67.48	2.27	4.44	30.13		P	
		7311	-95.55	-74.35	-21.2	-72.42	2.27	5.87	31.27		P	
802.11g CH 11 2462MHz		4924	-96.85	-75.65	-21.2	-73.48	2.27	4.47	30.11		P	
		7386	-94.62	-73.42	-21.2	-71.47	2.27	5.89	31.31		P	
Remark	1. No other spurious found. 2. All results are PASS against Peak and Average limit line.											



**2.4GHz 2400~2483.5MHz
WIFI 802.11n HT20 (Band Edge @ 3m)**

WIFI Ant. 1	Note	Frequency (MHz)	Level (dBm)	Over Limit (dB)	Limit Line (dBm)	Read Level (dBm)	Antenna Gain (dBi)	Cable Loss (dB)	Preamp Gain (dB)	Aux Gain (dB)	Peak Avg. (P/A)	
802.11n HT20 CH 01 2412MHz		2389.38	-49.52	-28.32	-21.2	-54.77	2.27	2.98			P	
		2389.65	-57.5	-16.3	-41.2	-62.75	2.27	2.98			A	
	*	2412	-19.59	-	-	-24.87	2.27	3.01			P	
	*	2412	-29.06	-	-	-34.34	2.27	3.01			A	
		2496.22	-54.36	-33.16	-21.2	-59.68	2.27	3.05			P	
		2497.55	-65.89	-24.69	-41.2	-71.21	2.27	3.05			A	
802.11n HT20 CH 06 2437MHz		2368.455	-54.7	-33.5	-21.2	-59.94	2.27	2.97			P	
		2345.505	-64.11	-22.91	-41.2	-69.33	2.27	2.95			A	
	*	2437	-16.93	-	-	-22.22	2.27	3.02			P	
	*	2437	-24.21	-	-	-29.5	2.27	3.02			A	
		2484.67	-54.73	-33.53	-21.2	-60.05	2.27	3.05			P	
		2496.57	-65.76	-24.56	-41.2	-71.08	2.27	3.05			A	



WIFI Ant. 1	Note	Frequency (MHz)	Level (dBm)	Over Limit (dB)	Limit Line (dBm)	Read Level (dBm)	Antenna Gain (dBi)	Cable Loss (dB)	Preamp Gain (dB)	Aux Gain (dB)	Peak Avg. (P/A)	
802.11n HT20 CH 11 2462MHz		2351.31	-55.03	-33.83	-21.2	-60.25	2.27	2.95			P	
		2369.67	-66.2	-25	-41.2	-71.44	2.27	2.97			A	
	*	2462	-18.14	-	-	-23.44	2.27	3.03			P	
	*	2462	-27.68	-	-	-32.98	2.27	3.03			A	
		2483.9	-46.29	-25.09	-21.2	-51.61	2.27	3.05			P	
		2484.18	-53.65	-12.45	-41.2	-58.97	2.27	3.05			A	
Remark	1. No other spurious found. 2. All results are PASS against Peak and Average limit line.											



**2.4GHz 2400~2483.5MHz
WIFI 802.11n HT20 (Harmonic @ 3m)**

WIFI Ant. 1	Note	Frequency (MHz)	Level (dBm)	Over Limit (dB)	Limit Line (dBm)	Read Level (dBm)	Antenna Gain (dBi)	Cable Loss (dB)	Preamp Gain (dB)	Aux Gain (dB)	Peak Avg. (P/A)
802.11n HT20 CH 01 2412MHz		4824	-85.36	-64.16	-21.2	-61.89	2.27	4.41	30.15		P
802.11n HT20 CH 06 2437MHz		4874	-93.13	-71.93	-21.2	-69.71	2.27	4.44	30.13		P
		7311	-93.36	-72.16	-21.2	-70.23	2.27	5.87	31.27		P
802.11n HT20 CH 11 2462MHz		4924	-95.66	-74.46	-21.2	-72.29	2.27	4.47	30.11		P
		7386	-95.17	-73.97	-21.2	-72.02	2.27	5.89	31.31		P
Remark	1. No other spurious found. 2. All results are PASS against Peak and Average limit line.										



**Emission below 1GHz
2.4GHz WIFI 802.11n HT20 (LF)**

WIFI	Note	Frequency	Level	Over	Limit	Read	Antenna	Cable	Preamp	Grounding	Peak	
Ant.		(MHz)	(dBm)	(dB)	(dBm)	(dBm)	(dBi)	(dB)	(dB)	(dB)	Avg.	
1											(P/A)	
2.4GHz 802.11n HT20 LF		119.91	-86.46	-34.76	-51.7	-59.51	2.27	0.55	32.2	4.7	P	
		240.06	-82.93	-33.73	-49.2	-56.3	2.27	0.84	32.17	4.7	P	
		299.19	-83.95	-34.75	-49.2	-57.48	2.27	0.9	32.07	4.7	P	
		364.4	-84.21	-35.01	-49.2	-57.84	2.27	1.03	32.1	4.7	P	
		785.1	-67.67	-18.47	-49.2	-41.98	2.27	1.58	31.97	4.7	P	
		934.2	-85.81	-36.61	-49.2	-61.11	2.27	1.75	31.15	4.7	P	
	Remark	1. No other spurious found. 2. All results are PASS against limit line.										



Note symbol

*	Fundamental Frequency which can be ignored. However, the level of any unwanted emissions shall not exceed the level of the fundamental frequency.
!	Test result is over limit line.
P/A	Peak or Average
H/V	Horizontal or Vertical



A calculation example for radiated spurious emission is shown as below:

WIFI	Note	Frequency	Level	Over	Limit	Read	Antenna	Cable	Preamp	Ant	Table	Peak	Pol.
Ant.				Limit	Line	Level	Gain	Loss	Gain	Pos	Pos	Avg.	
1		(MHz)	(dBμV/m)	(dB)	(dBμV/m)	(dBμV)	(dBi)	(dB)	(dB)	(cm)	(deg)	(P/A)	(H/V)
802.11b		2390	55.45	-18.55	74	54.51	32.22	4.58	35.86	103	308	P	H
CH 01													
2412MHz		2390	43.54	-10.46	54	42.6	32.22	4.58	35.86	103	308	A	H

- Level(dBμV/m) =
Antenna Gain(dBi) + Cable Loss(dB) + Read Level(dBμV) - Preamp Gain(dB)
- Over Limit(dB) = Level(dBμV/m) – Limit Line(dBμV/m)

For Peak Limit @ 2390MHz:

- Level(dBμV/m)
= Antenna Gain(dBi) + Cable Loss(dB) + Read Level(dBμV) - Preamp Gain(dB)
= 32.22(dB/m) + 4.58(dB) + 54.51(dBμV) – 35.86 (dB)
= 55.45 (dBμV/m)
- Over Limit(dB)
= Level(dBμV/m) – Limit Line(dBμV/m)
= 55.45(dBμV/m) – 74(dBμV/m)
= -18.55(dB)

For Average Limit @ 2390MHz:

- Level(dBμV/m)
= Antenna Gain(dBi) + Cable Loss(dB) + Read Level(dBμV) - Preamp Gain(dB)
= 32.22(dB/m) + 4.58(dB) + 42.6(dBμV) – 35.86 (dB)
= 43.54 (dBμV/m)
- Over Limit(dB)
= Level(dBμV/m) – Limit Line(dBμV/m)
= 43.54(dBμV/m) – 54(dBμV/m)
= -10.46(dB)

Both peak and average measured complies with the limit line, so test result is “PASS”.



Appendix F. Conducted Spurious Emission Plots (Restricted Band)

Test Engineer :	Rover Lee	Temperature :	22~24°C
		Relative Humidity :	53~56%

Note symbol

-L	Low channel location
-R	High channel location



2.4GHz 2400~2483.5MHz

WIFI 802.11b (Band Edge)

WIFI	2.4GHz 2400~2483.5MHz Band Edge	
ANT	802.11b CH01 2412MHz - L	
1	Band Edge	Fundamental
Peak	<p>Site : 03CH13-HY Condition : FCC CLASS-B_CON ANT_GAIN+2.27 HORIZONTAL RBW:1000.000kHz VBW:3000.000kHz SWT:Auto Detector : Peak Project : 601109 Mode : 1</p>	<p>Site : 03CH13-HY Condition : FCC CLASS-B_CON ANT_GAIN+2.27 HORIZONTAL RBW:1000.000kHz VBW:3000.000kHz SWT:Auto Detector : Peak Project : 601109 Mode : 1</p>
Avg.	<p>Site : 03CH13-HY Condition : FCC CLASS-B(AVG)_CON ANT_GAIN+2.27 HORIZONTAL RBW:1000.000kHz VBW:10.000kHz SWT:Auto Detector : Peak Project : 601109 Mode : 1</p>	<p>Site : 03CH13-HY Condition : FCC CLASS-B(AVG)_CON ANT_GAIN+2.27 HORIZONTAL RBW:1000.000kHz VBW:10.000kHz SWT:Auto Detector : Peak Project : 601109 Mode : 1</p>

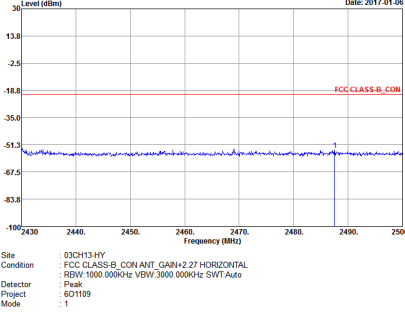
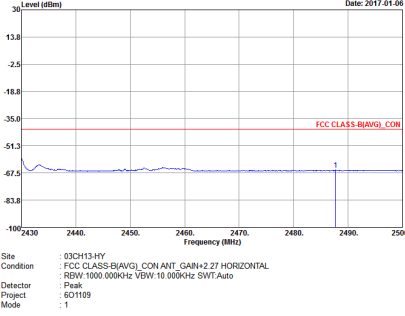

WIFI	2.4GHz 2400~2483.5MHz Band Edge	
ANT	802.11b CH01 2412MHz - R	
1	Band Edge	Fundamental
Peak		Left blank
Avg.		Left blank

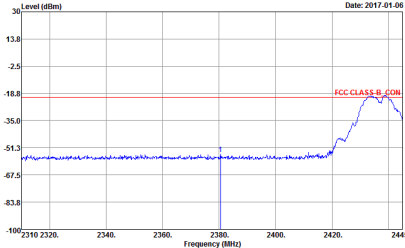
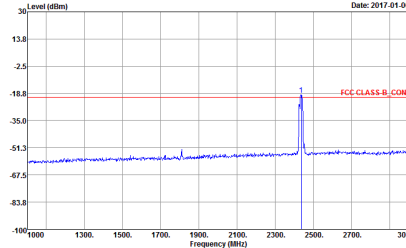
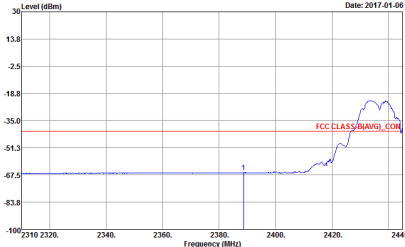
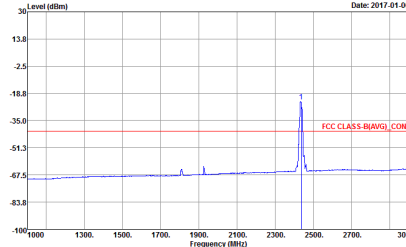

WIFI	2.4GHz 2400~2483.5MHz Band Edge	
ANT	802.11b CH06 2437MHz - L	
1	Band Edge	Fundamental
Peak	 <p>Level (dBm) vs Frequency (MHz) plot showing a peak at approximately 2437 MHz. The y-axis ranges from -100 to 30 dBm, and the x-axis ranges from 2310 to 2445 MHz. A red horizontal line indicates the FCC CLASS-B CON limit at -18.8 dBm.</p> <p>Site : 03CH13-HY Condition : FCC CLASS-B CON ANT_GAIN+2.27 HORIZONTAL RBW:1000.000KHz VBW:3000.000KHz SWT:Auto Detector : Peak Project : 601109 Mode : 2</p>	 <p>Level (dBm) vs Frequency (MHz) plot showing a sharp peak at 2437 MHz. The y-axis ranges from -100 to 30 dBm, and the x-axis ranges from 1900 to 3000 MHz. A red horizontal line indicates the FCC CLASS-B CON limit at -18.8 dBm.</p> <p>Site : 03CH13-HY Condition : FCC CLASS-B CON ANT_GAIN+2.27 HORIZONTAL RBW:1000.000KHz VBW:3000.000KHz SWT:Auto Detector : Peak Project : 601109 Mode : 2</p>
Avg.	 <p>Level (dBm) vs Frequency (MHz) plot showing the average spectrum with a peak at approximately 2437 MHz. The y-axis ranges from -100 to 30 dBm, and the x-axis ranges from 2310 to 2445 MHz. A red horizontal line indicates the FCC CLASS-B(AVG) CON limit at -51.3 dBm.</p> <p>Site : 03CH13-HY Condition : FCC CLASS-B(AVG) CON ANT_GAIN+2.27 HORIZONTAL RBW:1000.000KHz VBW:10.000KHz SWT:Auto Detector : Peak Project : 601109 Mode : 2</p>	 <p>Level (dBm) vs Frequency (MHz) plot showing the average spectrum with a sharp peak at 2437 MHz. The y-axis ranges from -100 to 30 dBm, and the x-axis ranges from 1900 to 3000 MHz. A red horizontal line indicates the FCC CLASS-B(AVG) CON limit at -51.3 dBm.</p> <p>Site : 03CH13-HY Condition : FCC CLASS-B(AVG) CON ANT_GAIN+2.27 HORIZONTAL RBW:1000.000KHz VBW:10.000KHz SWT:Auto Detector : Peak Project : 601109 Mode : 2</p>



WIFI	2.4GHz 2400~2483.5MHz Band Edge	
ANT	802.11b CH06 2437MHz - R	
1	Band Edge	Fundamental
<p>Peak</p>	<p>Date: 2017-01-06</p> <p>Site : 03CH13-HY Condition : FCC CLASS-B_CON ANT_GAIN+2.27 HORIZONTAL RBW: 1000.000KHz VBW: 3000.000KHz SWT: Auto Detector : Peak Project : 601109 Mode : 2</p>	<p>Left blank</p>
<p>Avg.</p>	<p>Date: 2017-01-06</p> <p>Site : 03CH13-HY Condition : FCC CLASS-B(AVG)_CON ANT_GAIN+2.27 HORIZONTAL RBW: 1000.000KHz VBW: 10.000KHz SWT: Auto Detector : Peak Project : 601109 Mode : 2</p>	<p>Left blank</p>

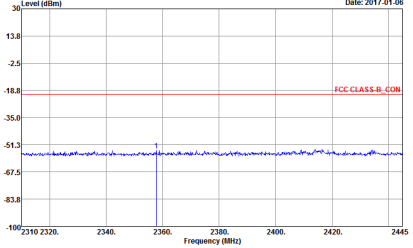
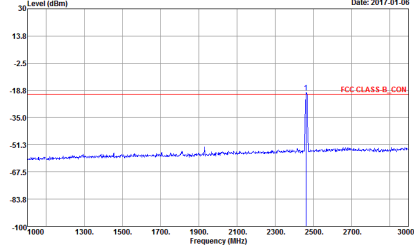
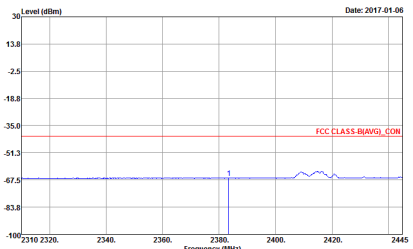
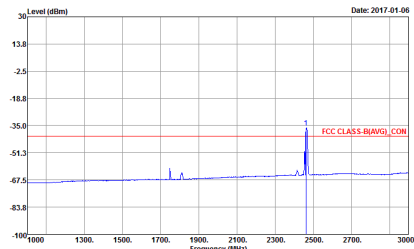

WIFI	2.4GHz 2400~2483.5MHz Band Edge	
ANT	802.11b CH11 2462MHz - L	
1	Band Edge	Fundamental
Peak	 <p>Date: 2017-01-06</p> <p>Site : 03CH13-HY Condition : FCC CLASS-B CON ANT_GAIN+2.27 HORIZONTAL RBW: 1000.000kHz VBW: 3000.000kHz SWT: Auto Detector : Peak Project : 601109 Mode : 3</p>	 <p>Date: 2017-01-06</p> <p>Site : 03CH13-HY Condition : FCC CLASS-B CON ANT_GAIN+2.27 HORIZONTAL RBW: 1000.000kHz VBW: 3000.000kHz SWT: Auto Detector : Peak Project : 601109 Mode : 3</p>
Avg.	 <p>Date: 2017-01-06</p> <p>Site : 03CH13-HY Condition : FCC CLASS-B(AVG)_CON ANT_GAIN+2.27 HORIZONTAL RBW: 1000.000kHz VBW: 10.000kHz SWT: Auto Detector : Peak Project : 601109 Mode : 3</p>	 <p>Date: 2017-01-06</p> <p>Site : 03CH13-HY Condition : FCC CLASS-B(AVG)_CON ANT_GAIN+2.27 HORIZONTAL RBW: 1000.000kHz VBW: 10.000kHz SWT: Auto Detector : Peak Project : 601109 Mode : 3</p>



WIFI	2.4GHz 2400~2483.5MHz Band Edge	
ANT	802.11b CH11 2462MHz - R	
1	Band Edge	Fundamental
<p>Peak</p>	<p>Date: 2017-01-06</p> <p>Site : 03CH13-HY Condition : FCC CLASS-B_CON ANT_GAIN+2.27 HORIZONTAL RBW: 1000.000KHz VBW: 3000.000KHz SWT: Auto Detector : Peak Project : 601109 Mode : 3</p>	<p>Left blank</p>
<p>Avg.</p>	<p>Date: 2017-01-06</p> <p>Site : 03CH13-HY Condition : FCC CLASS-B_BWAGI_CON ANT_GAIN+2.27 HORIZONTAL RBW: 1000.000KHz VBW: 10.000KHz SWT: Auto Detector : Peak Project : 601109 Mode : 3</p>	<p>Left blank</p>



2.4GHz 2400~2483.5MHz

WIFI 802.11g (Band Edge)

WIFI	2.4GHz 2400~2483.5MHz Band Edge	
ANT	802.11g CH01 2412MHz - L	
1	Band Edge	Fundamental
Peak	<p>Site : 03CH13-HY Condition : FCC CLASS-B_CON ANT_GAIN+2.27 HORIZONTAL RBW:1000.000kHz VBW:3000.000kHz SWT:Auto Detector : Peak Project : 601109 Mode : 4</p>	<p>Site : 03CH13-HY Condition : FCC CLASS-B_CON ANT_GAIN+2.27 HORIZONTAL RBW:1000.000kHz VBW:3000.000kHz SWT:Auto Detector : Peak Project : 601109 Mode : 4</p>
Avg.	<p>Site : 03CH13-HY Condition : FCC CLASS-B(AVG)_CON ANT_GAIN+2.27 HORIZONTAL RBW:1000.000kHz VBW:10.000kHz SWT:Auto Detector : Peak Project : 601109 Mode : 4</p>	<p>Site : 03CH13-HY Condition : FCC CLASS-B(AVG)_CON ANT_GAIN+2.27 HORIZONTAL RBW:1000.000kHz VBW:10.000kHz SWT:Auto Detector : Peak Project : 601109 Mode : 4</p>

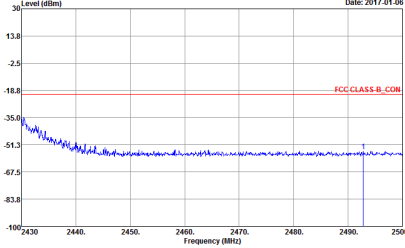
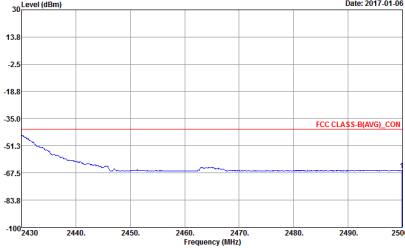

WIFI	2.4GHz 2400~2483.5MHz Band Edge	
ANT	802.11g CH01 2412MHz - R	
1	Band Edge	Fundamental
Peak	 <p>Date: 2017-01-06</p> <p>Site : 03CH13-HY Condition : FCC CLASS-B_CON ANT_GAIN+2.27 HORIZONTAL RBW: 1000.000KHz VBW: 3000.000KHz SWT: Auto Detector : Peak Project : 601109 Mode : 4</p>	Left blank
Avg.	 <p>Date: 2017-01-06</p> <p>Site : 03CH13-HY Condition : FCC CLASS-B(AVG)_CON ANT_GAIN+2.27 HORIZONTAL RBW: 1000.000KHz VBW: 10.000KHz SWT: Auto Detector : Peak Project : 601109 Mode : 4</p>	Left blank



WIFI	2.4GHz 2400~2483.5MHz Band Edge	
ANT	802.11g CH06 2437MHz - L	
1	Band Edge	Fundamental
Peak	<p> Site : 03CH13-HY Condition : FCC CLASS-B_CON ANT_GAIN+2.27 HORIZONTAL RBW:1000.000KHz VBW:3000.000KHz SWT:Auto Detector : Peak Project : 601109 Mode : 5 </p>	<p> Site : 03CH13-HY Condition : FCC CLASS-B_CON ANT_GAIN+2.27 HORIZONTAL RBW:1000.000KHz VBW:3000.000KHz SWT:Auto Detector : Peak Project : 601109 Mode : 5 </p>
Avg.	<p> Site : 03CH13-HY Condition : FCC CLASS-B(AVG)_CON ANT_GAIN+2.27 HORIZONTAL RBW:1000.000KHz VBW:10.000KHz SWT:Auto Detector : Peak Project : 601109 Mode : 5 </p>	<p> Site : 03CH13-HY Condition : FCC CLASS-B(AVG)_CON ANT_GAIN+2.27 HORIZONTAL RBW:1000.000KHz VBW:10.000KHz SWT:Auto Detector : Peak Project : 601109 Mode : 5 </p>



WIFI	2.4GHz 2400~2483.5MHz Band Edge	
ANT	802.11g CH06 2437MHz - R	
1	Band Edge	Fundamental
<p>Peak</p>	<p>Site : 03CH13-HY Condition : FCC CLASS-B_CON ANT_GAIN+2.27 HORIZONTAL RBW:1000.000KHz VBW:3000.000KHz SWT:Auto Detector : Peak Project : 601109 Mode : 5</p>	<p>Left blank</p>
<p>Avg.</p>	<p>Site : 03CH13-HY Condition : FCC CLASS-B(AVG)_CON ANT_GAIN+2.27 HORIZONTAL RBW:1000.000KHz VBW:10.000KHz SWT:Auto Detector : Peak Project : 601109 Mode : 5</p>	<p>Left blank</p>



WIFI	2.4GHz 2400~2483.5MHz Band Edge	
ANT	802.11g CH11 2462MHz - L	
1	Band Edge	Fundamental
Peak	<p>Site : 03CH13-HY Condition : FCC CLASS-B_CON ANT_GAIN+2.27 HORIZONTAL RBW: 1000.000kHz VBW: 3000.000kHz SWT: Auto Detector : Peak Project : 601109 Mode : 6</p>	<p>Site : 03CH13-HY Condition : FCC CLASS-B_CON ANT_GAIN+2.27 HORIZONTAL RBW: 1000.000kHz VBW: 3000.000kHz SWT: Auto Detector : Peak Project : 601109 Mode : 6</p>
Avg.	<p>Site : 03CH13-HY Condition : FCC CLASS-B(AVG)_CON ANT_GAIN+2.27 HORIZONTAL RBW: 1000.000kHz VBW: 10.000kHz SWT: Auto Detector : Peak Project : 601109 Mode : 6</p>	<p>Site : 03CH13-HY Condition : FCC CLASS-B(AVG)_CON ANT_GAIN+2.27 HORIZONTAL RBW: 1000.000kHz VBW: 10.000kHz SWT: Auto Detector : Peak Project : 601109 Mode : 6</p>

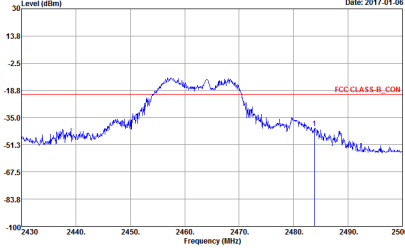
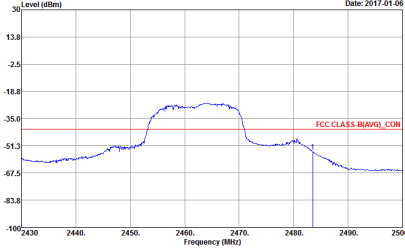

WIFI	2.4GHz 2400~2483.5MHz Band Edge	
ANT	802.11g CH11 2462MHz - R	
1	Band Edge	Fundamental
<p>Peak</p>	 <p>Date: 2017-01-06</p> <p>Site : 03CH13-HY Condition : FCC CLASS-B_CON ANT_GAIN+2.27 HORIZONTAL RBW: 1000.000kHz VBW: 3000.000kHz SWT: Auto Detector : Peak Project : 601109 Mode : 6</p>	<p>Left blank</p>
<p>Avg.</p>	 <p>Date: 2017-01-06</p> <p>Site : 03CH13-HY Condition : FCC CLASS-B(AVG)_CON ANT_GAIN+2.27 HORIZONTAL RBW: 1000.000kHz VBW: 10.000kHz SWT: Auto Detector : Peak Project : 601109 Mode : 6</p>	<p>Left blank</p>



2.4GHz 2400~2483.5MHz
WIFI 802.11n HT20 (Band Edge)

WIFI	2.4GHz 2400~2483.5MHz Band Edge	
ANT	802.11n HT20 CH01 2412MHz - L	
1	Band Edge	Fundamental
Peak	<p> Date: 2017-01-06 Site : 03CH13-HY Condition : FCC CLASS-B_CON ANT_GAIN+2.27 HORIZONTAL RBW:1000.000kHz VBW:3000.000kHz SWT:Auto Detector : Peak Project : 601109 Mode : 7 </p>	<p> Date: 2017-01-06 Site : 03CH13-HY Condition : FCC CLASS-B_CON ANT_GAIN+2.27 HORIZONTAL RBW:1000.000kHz VBW:3000.000kHz SWT:Auto Detector : Peak Project : 601109 Mode : 7 </p>
Avg.	<p> Date: 2017-01-06 Site : 03CH13-HY Condition : FCC CLASS-B(AVG)_CON ANT_GAIN+2.27 HORIZONTAL RBW:1000.000kHz VBW:10.000kHz SWT:Auto Detector : Peak Project : 601109 Mode : 7 </p>	<p> Date: 2017-01-06 Site : 03CH13-HY Condition : FCC CLASS-B(AVG)_CON ANT_GAIN+2.27 HORIZONTAL RBW:1000.000kHz VBW:10.000kHz SWT:Auto Detector : Peak Project : 601109 Mode : 7 </p>



WIFI	2.4GHz 2400~2483.5MHz Band Edge	
ANT	802.11n HT20 CH01 2412MHz - R	
1	Band Edge	Fundamental
<p>Peak</p>	<p>Date: 2017-01-06</p> <p>Site : 03CH13-HY Condition : FCC CLASS-B_CON ANT_GAIN+2.27 HORIZONTAL RBW: 1000.000kHz VBW: 3000.000kHz SWT: Auto Detector : Peak Project : 601109 Mode : 7</p>	<p>Left blank</p>
<p>Avg.</p>	<p>Date: 2017-01-06</p> <p>Site : 03CH13-HY Condition : FCC CLASS-B(AVG)_CON ANT_GAIN+2.27 HORIZONTAL RBW: 1000.000kHz VBW: 10.000kHz SWT: Auto Detector : Peak Project : 601109 Mode : 7</p>	<p>Left blank</p>

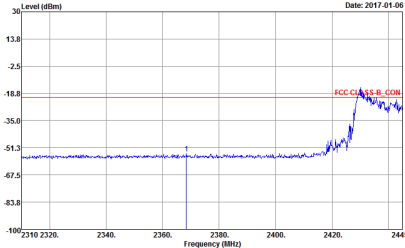
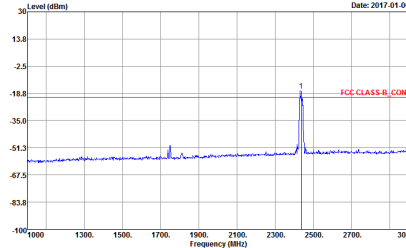
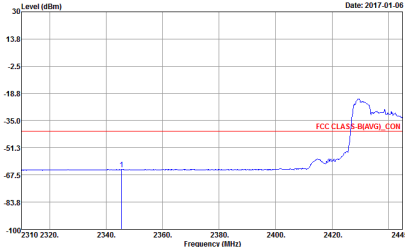
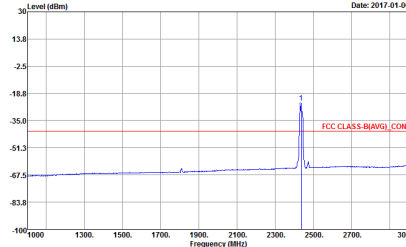

WIFI	2.4GHz 2400~2483.5MHz Band Edge	
ANT	802.11n HT20 CH06 2437MHz - L	
1	Band Edge	Fundamental
Peak	 <p>Date: 2017-01-06</p> <p>Site : 03CH13-HY Condition : FCC CLASS-B CON ANT_GAIN+2.27 HORIZONTAL RBW:1000.000kHz VBW:3000.000kHz SWT:Auto Detector : Peak Project : 601109 Mode : 8</p>	 <p>Date: 2017-01-06</p> <p>Site : 03CH13-HY Condition : FCC CLASS-B CON ANT_GAIN+2.27 HORIZONTAL RBW:1000.000kHz VBW:3000.000kHz SWT:Auto Detector : Peak Project : 601109 Mode : 8</p>
Avg.	 <p>Date: 2017-01-06</p> <p>Site : 03CH13-HY Condition : FCC CLASS-B(AVG)_CON ANT_GAIN+2.27 HORIZONTAL RBW:1000.000kHz VBW:10.000kHz SWT:Auto Detector : Peak Project : 601109 Mode : 8</p>	 <p>Date: 2017-01-06</p> <p>Site : 03CH13-HY Condition : FCC CLASS-B(AVG)_CON ANT_GAIN+2.27 HORIZONTAL RBW:1000.000kHz VBW:10.000kHz SWT:Auto Detector : Peak Project : 601109 Mode : 8</p>

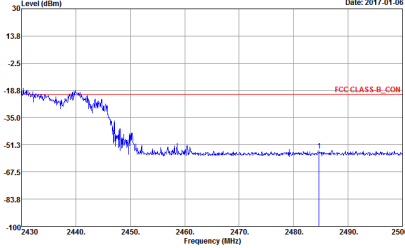
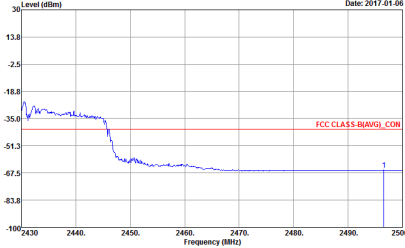

WIFI	2.4GHz 2400~2483.5MHz Band Edge	
ANT	802.11n HT20 CH06 2437MHz - R	
1	Band Edge	Fundamental
<p>Peak</p>	 <p>Date: 2017-01-06</p> <p>Site : 03CH13-HY Condition : FCC CLASS-B_CON ANT_GAIN=2.27 HORIZONTAL RBW: 1000.000KHz VBW: 3000.000KHz SWT: Auto Detector : Peak Project : 601109 Mode : 8</p>	<p>Left blank</p>
<p>Avg.</p>	 <p>Date: 2017-01-06</p> <p>Site : 03CH13-HY Condition : FCC CLASS-B(AVG)_CON ANT_GAIN=2.27 HORIZONTAL RBW: 1000.000KHz VBW: 10.000KHz SWT: Auto Detector : Peak Project : 601109 Mode : 8</p>	<p>Left blank</p>

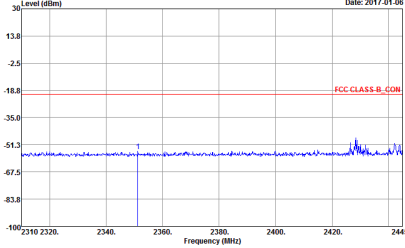
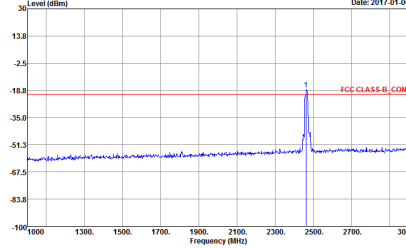
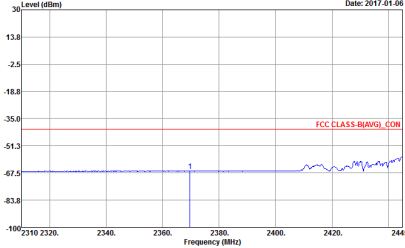
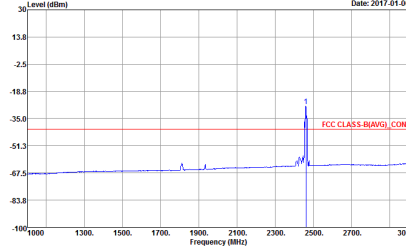

WIFI	2.4GHz 2400~2483.5MHz Band Edge	
ANT	802.11n HT20 CH11 2462MHz - L	
1	Band Edge	Fundamental
Peak	 <p>Date: 2017-01-06</p> <p>Level (dBm) vs Frequency (MHz)</p> <p>FCC CLASS-B_CON</p> <p>Site : 03CH13-HY Condition : FCC CLASS-B_CON ANT_GAIN+2.27 HORIZONTAL RBW: 1000.000kHz VBW: 3000.000kHz SWT: Auto Detector : Peak Project : 601109 Mode : 9</p>	 <p>Date: 2017-01-06</p> <p>Level (dBm) vs Frequency (MHz)</p> <p>FCC CLASS-B_CON</p> <p>Site : 03CH13-HY Condition : FCC CLASS-B_CON ANT_GAIN+2.27 HORIZONTAL RBW: 1000.000kHz VBW: 3000.000kHz SWT: Auto Detector : Peak Project : 601109 Mode : 9</p>
Avg.	 <p>Date: 2017-01-06</p> <p>Level (dBm) vs Frequency (MHz)</p> <p>FCC CLASS-B(AVG)_CON</p> <p>Site : 03CH13-HY Condition : FCC CLASS-B(AVG)_CON ANT_GAIN+2.27 HORIZONTAL RBW: 1000.000kHz VBW: 10.000kHz SWT: Auto Detector : Peak Project : 601109 Mode : 9</p>	 <p>Date: 2017-01-06</p> <p>Level (dBm) vs Frequency (MHz)</p> <p>FCC CLASS-B(AVG)_CON</p> <p>Site : 03CH13-HY Condition : FCC CLASS-B(AVG)_CON ANT_GAIN+2.27 HORIZONTAL RBW: 1000.000kHz VBW: 10.000kHz SWT: Auto Detector : Peak Project : 601109 Mode : 9</p>

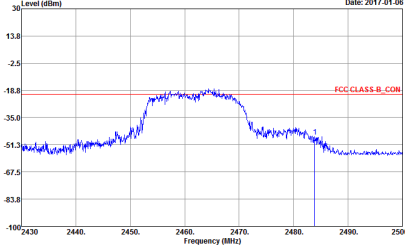
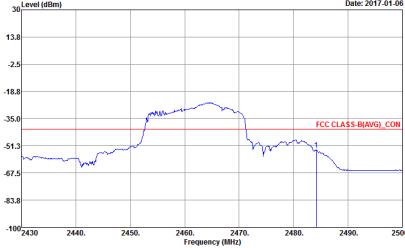

WIFI	2.4GHz 2400~2483.5MHz Band Edge	
ANT	802.11n HT20 CH11 2462MHz - R	
1	Band Edge	Fundamental
<p>Peak</p>	 <p>Date: 2017-01-06</p> <p>Site : 03CH13-HY Condition : FCC CLASS-B_CON ANT_GAIN=2.27 HORIZONTAL RBW: 1000.000KHz VBW: 3000.000KHz SWT: Auto Detector : Peak Project : 601109 Mode : 9</p>	<p>Left blank</p>
<p>Avg.</p>	 <p>Date: 2017-01-06</p> <p>Site : 03CH13-HY Condition : FCC CLASS-B(AVG)_CON ANT_GAIN=2.27 HORIZONTAL RBW: 1000.000KHz VBW: 10.000KHz SWT: Auto Detector : Peak Project : 601109 Mode : 9</p>	<p>Left blank</p>



2.4GHz 2400~2483.5MHz

WIFI 802.11b (Harmonic)

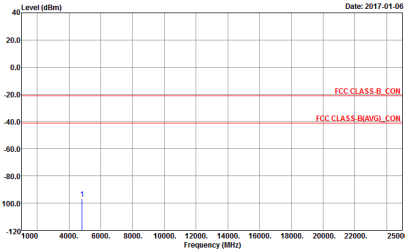
WIFI	2.4GHz 2400~2483.5MHz Harmonic	
ANT	802.11b CH01 2412MHz	
1		
Peak Avg.	 <p>Site: 03CH13-HY Condition: FCC CLASS-B_CON ANT_GAIN+2.27 HORIZONTAL Detector: Peak Project: 601109 Mode: 1</p>	Left blank



WIFI	2.4GHz 2400~2483.5MHz Harmonic	
ANT	802.11b CH06 2437MHz	
1		
Peak Avg.	<p>Site: 03CH131HY Condition: FCC CLASS-B_CON ANT_GAIN+2.27 HORIZONTAL Detector: Peak Project: 601109 Mode: 2</p>	Left blank



WIFI	2.4GHz 2400~2483.5MHz Harmonic	
ANT	802.11b CH11 2462MHz	
1		
Peak Avg.	<p>Site: 03CH131HY Condition: FCC CLASS-B_CON ANT_GAIN+2.27 HORIZONTAL Detector: Peak Project: 601109 Mode: 3</p>	Left blank



2.4GHz 2400~2483.5MHz

WIFI 802.11g (Harmonic)

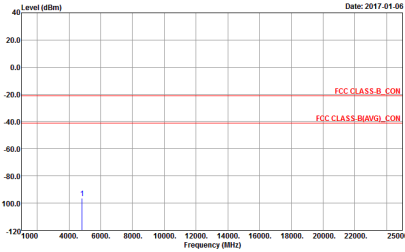
WIFI	2.4GHz 2400~2483.5MHz Harmonic	
ANT	802.11g CH01 2412MHz	
1		
Peak Avg.	 <p>Site: 03CH13-HY Condition: FCC CLASS-B_CON ANT_GAIN+2.27 HORIZONTAL Detector: Peak Project: 601109 Mode: 4</p>	Left blank

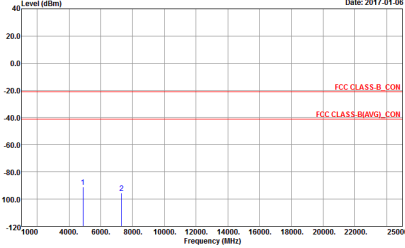

WIFI	2.4GHz 2400~2483.5MHz Harmonic	
ANT	802.11g CH06 2437MHz	
1		
<p>Peak Avg.</p>	 <p>Date: 2017-01-06</p> <p>Site : 03CH13-11Y Condition : FCC CLASS-B CON ANT_GAIN+2.27 HORIZONTAL Detector : RBW:1000.000KHz VBW:3000.000KHz SWF:Auto Peak : Project : 601109 Mode : 5</p>	<p>Left blank</p>



WIFI	2.4GHz 2400~2483.5MHz Harmonic	
ANT	802.11g CH11 2462MHz	
1		
Peak Avg.	<p>Site: 03CH131HY Condition: FCC CLASS-B_CON ANT_GAIN+2.27 HORIZONTAL Detector: Peak Project: 601109 Mode: 6</p>	Left blank



2.4GHz 2400~2483.5MHz

WIFI 802.11n HT20 (Harmonic)

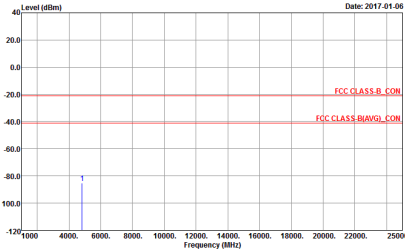
WIFI	2.4GHz 2400~2483.5MHz Harmonic	
ANT	802.11n HT20 CH01 2412MHz	
1		
Peak Avg.	 <p>Site: 03CH13-HY Condition: FCC CLASS-B_CON ANT_GAIN+2.27 HORIZONTAL Detector: Peak Project: 601109 Mode: 7</p>	Left blank



WIFI	2.4GHz 2400~2483.5MHz Harmonic	
ANT	802.11n HT20 CH06 2437MHz	
1		
Peak Avg.	<p>Site: 03CH131HY Condition: FCC CLASS-B_CON ANT_GAIN+2.27 HORIZONTAL Detector: Peak Project: 601109 Mode: 8</p>	Left blank



WIFI	2.4GHz 2400~2483.5MHz Harmonic	
ANT	802.11n HT20 CH11 2462MHz	
1		
Peak Avg.	<p>Site: 03CH13-11Y Condition: FCC CLASS-B_CON ANT_GAIN+2.27 HORIZONTAL Detector: Peak Project: 601109 Mode: 9</p>	Left blank



Emission below 1GHz
2.4GHz WIFI 802.11n HT20 (LF)

WIFI	2.4GHz 2400~2483.5MHz	
ANT	802.11n HT20 LF	
1		
QP / Peak	<p>Level (dbm) Date: 2017-01-11</p> <p>FCC CLASS B CON</p> <p>Site : 03CH13-HY Condition : FCC CLASS-B CON ANT GAIN+2.27 HORIZONTAL RBW:120.000kHz VBW:300.000kHz SWT:0.500sec Detector : Peak Project : 601109 Mode : 13</p>	Left blank