



EMI TEST REPORT

Test Report No. : 12742873H-B-R1

Applicant : Sumitomo Wiring Systems, Ltd.
Type of Equipment : UNIT ASSY, BCM
Model No. : HAR0004
FCC ID : 2AKB8HAR0004
Test regulation : FCC Part 15 Subpart B: 2018
Test Result : Complied (Refer to SECTION 3.2)

1. This test report shall not be reproduced in full or partial, without the written approval of UL Japan, Inc.
2. The results in this report apply only to the sample tested.
3. This sample tested is in compliance with the above regulation.
4. The test results in this report are traceable to the national or international standards.
5. This test report covers EMC technical requirements. It does not cover administrative issues such as Manual or non-EMC test related Requirements. (if applicable)
6. The all test items in this test report are conducted by UL Japan, Inc. Ise EMC Lab.
7. This test report must not be used by the customer to claim product certification, approval, or endorsement by NVLAP, NIST, or any agency of the Federal Government.
8. The information provided from the customer for this report is identified in SECTION 1.
9. This report is a revised version of 12742873H-B. 12742873H-B is replaced with this report.

Date of test: March 20, 2019

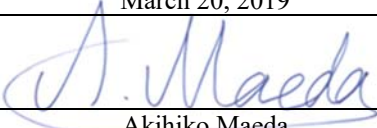
Representative test engineer: 
Akihiko Maeda
Engineer
Consumer Technology Division

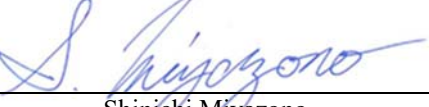
Approved by: 
Shinichi Miyazono
Engineer
Consumer Technology Division

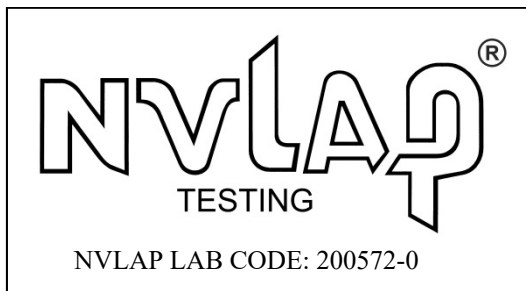

This laboratory is accredited by the NVLAP LAB CODE 200572-0, U.S.A. The tests reported herein have been performed in accordance with its terms of accreditation.
*As for the range of Accreditation in NVLAP, you may refer to the WEB address,
http://japan.ul.com/resources/emc_accredited/

- The testing in which "Non-accreditation" is displayed is outside the accreditation scopes in UL Japan.
 There is no testing item of "Non-accreditation".

UL Japan, Inc.
Ise EMC Lab.

4383-326 Asama-cho, Ise-shi, Mie-ken 516-0021 JAPAN
Telephone : +81 596 24 8999
Facsimile : +81 596 24 8124

CONTENTS	PAGE
SECTION 1: Customer information	4
SECTION 2: Equipment under test (E.U.T.).....	4
SECTION 3: Test specification, procedures & results	5
SECTION 4: Operation of E.U.T. during testing.....	8
SECTION 5: Radiated Emission.....	10
APPENDIX 1: Test data	12
Radiated emission	12
APPENDIX 2: Test instruments	14
APPENDIX 3: Photographs of test setup.....	15
Radiated Emission	15
Worst Case Position.....	17

SECTION 1: Customer information

Company Name : Sumitomo Wiring Systems, Ltd.
Address : 1820 Nakanoike, Mikkaichi-cho, Suzuka-City, Mie Pref. 513-8631
JAPAN
Telephone Number : +81-59-382-8711
Facsimile Number : +81-59-383-3943
Contact Person : Mamoru Nakanishi

The information provided from the customer is as follows;

- Applicant, Type of Equipment, Model No. on the cover and other relevant pages
- SECTION 1: Customer information
- SECTION 2: Equipment under test (E.U.T.)
- SECTION 4: Operation of E.U.T. during testing

* The laboratory is exempted from liability of any test results affected from the above information in SECTION 2 and 4.

SECTION 2: Equipment under test (E.U.T.)

2.1 Identification of E.U.T.

Type of Equipment : UNIT ASSY, BCM
Model No. : HAR0004
Serial No. : Refer to Section 4, Clause 4.2
Rating : DC 12 V
Receipt Date of Sample : February 24, 2019
(Information from test lab.)
Country of Mass-production : United States of America , China , Thailand, Japan
Condition of EUT : Production prototype
(Not for Sale: This sample is equivalent to mass-produced items.)
Modification of EUT : No Modification by the test lab

2.2 Product Description

Model: HAR0004 (referred to as the EUT in this report) is a UNIT ASSY, BCM.

General Specification

Clock frequencies in the system : LF Transmitter: 9.000 MHz
RF Receiver: 24.305 MHz

Radio Specification

[LF Transmitter]*

Radio Type : Transmitter
Frequency of Operation : 125 kHz
Modulation : OOK (ASK)
Antenna Type : BAR Antenna, COIL Antenna

*The test of transmitter part was performed separately from this test report, and the conformability is confirmed.

[RF Receiver]

Radio Type : Receiver
Frequency of Operation : 433.92 MHz
Receiver Bandwidth : ±146 kHz
Intermediate Frequency : 250 kHz

FCC15.111(b)

The receiving antenna (of this EUT) is installed inside the EUT and cannot be removed (permanently attached).
Therefore, Radiated emission test was performed.

UL Japan, Inc.

Ise EMC Lab.

4383-326 Asama-cho, Ise-shi, Mie-ken 516-0021 JAPAN

Telephone : +81 596 24 8999

Facsimile : +81 596 24 8124

SECTION 3: Test specification, procedures & results

3.1 Test Specification

Test Specification : FCC Part 15 Subpart B
FCC Part 15 final revised on March 12, 2018 and effective April 11, 2018

Title : FCC 47CFR Part15 Radio Frequency Device
Subpart B Unintentional Radiators

3.2 Procedures and results

Item	Test Procedure	Limits	Deviation	Worst margin	Result	Remarks
Conducted emission	FCC: ANSI C63.4: 2014 7. AC power - line conducted emission measurements	FCC:Part 15 Subpart B 15.107(a)	N/A	N/A	N/A	*1)
	IC: RSS-Gen 8.8	IC: RSS-Gen 8.8				
Radiated emission	FCC: ANSI C63.4: 2014 8. Radiated emission measurements	FCC: Part 15 Subpart B 15.109(a)	N/A	19.86 dB 867.340 MHz Vertical, QP	Complied a)	-
	IC: RSS-Gen 7	IC: RSS-Gen 7.1.2				
*Note: UL Japan, Inc's EMI Work Procedure 13-EM-W0420.						
*1) The test is not applicable since the EUT is not the device that is designed to be connected to the public utility (AC) power line.						
a) Refer to APPENDIX 1 (data of Radiated emission)						
Symbols:						
Complied		The data of this test item has enough margin, more than the measurement uncertainty.				
Complied#		The data of this test item meets the limits unless the measurement uncertainty is taken into consideration.				

3.3 Addition to standard

No addition, exclusion nor deviation has been made from the standard.

3.4 Uncertainty

There is no applicable rule of uncertainty in this applied standard. Therefore, the following results are derived depending on whether or not laboratory uncertainty is applied.

The following uncertainties have been calculated to provide a confidence level of 95 % using a coverage factor $k = 2$.

Test distance	Radiated emission (+/-)
	9 kHz to 30 MHz
3 m	3.3 dB
10 m	3.2 dB

*Measurement distance

Polarity	Radiated emission (Below 1 GHz)			
	(3 m*)(+/-)		(10 m*)(+/-)	
	30 MHz to 200 MHz	200 MHz to 1000 MHz	30 MHz to 200 MHz	200 MHz to 1000 MHz
Horizontal	4.8 dB	5.2 dB	4.8 dB	5.0 dB
Vertical	5.0 dB	6.3 dB	4.9 dB	5.0 dB

Radiated emission (Above 1 GHz)				
(3 m*)(+/-)		(1 m*)(+/-)		(10 m*)(+/-)
1 GHz to 6 GHz	6 GHz to 18 GHz	10 GHz to 26.5 GHz	26.5 GHz to 40 GHz	1 GHz to 18 GHz
5.0 dB	5.3 dB	5.8 dB	5.8 dB	5.2 dB

* Measurement distance

3.5 Test Location

UL Japan, Inc. Ise EMC Lab.
4383-326 Asama-cho, Ise-shi, Mie-ken 516-0021 JAPAN
Telephone: +81 596 24 8999, Facsimile: +81 596 24 8124
NVLAP Lab. code: 200572-0 / FCC Test Firm Registration Number: 199967

Test site	IC Registration Number	Width x Depth x Height (m)	Size of reference ground plane (m) / horizontal conducting plane	Other rooms	Maximum measurement distance
No.1 semi-anechoic chamber	2973C-1	19.2 x 11.2 x 7.7	7.0 x 6.0	No.1 Power source room	10 m
No.2 semi-anechoic chamber	2973C-2	7.5 x 5.8 x 5.2	4.0 x 4.0	-	3 m
No.3 semi-anechoic chamber	2973C-3	12.0 x 8.5 x 5.9	6.8 x 5.75	No.3 Preparation room	3 m
No.3 shielded room	-	4.0 x 6.0 x 2.7	N/A	-	-
No.4 semi-anechoic chamber	2973C-4	12.0 x 8.5 x 5.9	6.8 x 5.75	No.4 Preparation room	3 m
No.4 shielded room	-	4.0 x 6.0 x 2.7	N/A	-	-
No.5 semi-anechoic chamber	-	6.0 x 6.0 x 3.9	6.0 x 6.0	-	-
No.6 shielded room	-	4.0 x 4.5 x 2.7	4.0 x 4.5	-	-
No.6 measurement room	-	4.75 x 5.4 x 3.0	4.75 x 4.15	-	-
No.7 shielded room	-	4.7 x 7.5 x 2.7	4.7 x 7.5	-	-
No.8 measurement room	-	3.1 x 5.0 x 2.7	3.1 x 5.0	-	-
No.9 measurement room	-	8.8 x 4.6 x 2.8	2.4 x 2.4	-	-
No.11 measurement room	-	6.2 x 4.7 x 3.0	4.8 x 4.6	-	-

* Size of vertical conducting plane (for Conducted Emission test) : 2.0 m x 2.0 m for No.1, No.2, No.3, and No.4 semi-anechoic chambers and No.3 and No.4 shielded rooms.

3.6 Test data, Test instruments, and Test set up

Refer to APPENDIX.

SECTION 4: Operation of E.U.T. during testing

4.1 Operating Mode(s)

Mode	Remarks
1) Receiving mode	-

- *The test signal level was confirmed to be sufficient to stabilize the local oscillator of the EUT.
- * It was confirmed by using checker that the EUT receives the signal from the transmitter (pair of EUT).

4.2 Configuration and peripherals

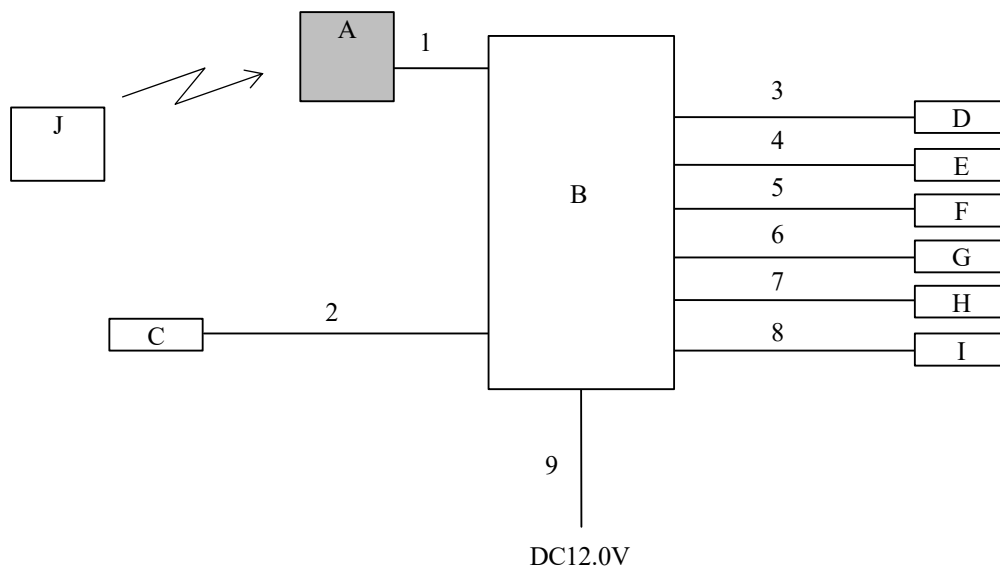

- * Cabling and setup(s) were taken into consideration and test data was taken under worse case conditions.
- *Item No. A includes Receiver Antenna.

Description of EUT and Support equipment

No.	Item	Model number	Serial number	Manufacturer	Remark
A	UNIT ASSY, BCM	HAR0004	003	Sumitomo Wiring Systems, Ltd.	EUT
B	Checker Box	TVA-001	-	Sumitomo Wiring Systems, Ltd.	-
C	Start Button	35881-TBA-A010-M1	290616AG G400041A	Sumitomo Wiring Systems, Ltd.	-
D	LF Antenna (R)	38387-T00-Z010-M1	001	Sumitomo Wiring Systems, Ltd.	-
E	LF Antenna (M)	38387-TVA-A310-M1	R16MC644007	Sumitomo Wiring Systems, Ltd.	-
F	LF Antenna (F)	38387-TVA-A310-M1	R16MC644031	Sumitomo Wiring Systems, Ltd.	-
G	LF Antenna (TR)	38387-TVA-A310-M1	R16MC644015	Sumitomo Wiring Systems, Ltd.	-
H	LF Antenna (FRAS)	38387-TVA-A310-M1	R16MC6510008	Sumitomo Wiring Systems, Ltd.	-
I	LF Antenna (FRDR)	38387-TVA-A310-M1	R16MC6510043	Sumitomo Wiring Systems, Ltd.	-
J	FOB	72147-TVA-H1	001	Sumitomo Wiring Systems, Ltd.	-

List of cables used

No.	Name	Length (m)	Shield		Remark
			Cable	Connector	
1	Signal Cable	2.5	Unshielded	Unshielded	-
2	Antenna Cable	2.5	Unshielded	Unshielded	-
3	Antenna Cable	2.5	Unshielded	Unshielded	-
4	Antenna Cable	2.5	Unshielded	Unshielded	-
5	Antenna Cable	2.5	Unshielded	Unshielded	-
6	Antenna Cable	2.5	Unshielded	Unshielded	-
7	Antenna Cable	2.5	Unshielded	Unshielded	-
8	Antenna Cable	2.5	Unshielded	Unshielded	-
9	DC Cable	0.9	Unshielded	Unshielded	-

UL Japan, Inc.

Ise EMC Lab.

4383-326 Asama-cho, Ise-shi, Mie-ken 516-0021 JAPAN

Telephone : +81 596 24 8999

Facsimile : +81 596 24 8124

SECTION 5: Radiated Emission

5.1. Operating environment

Test place : No.4 semi anechoic chamber
Temperature : See data
Humidity : See data

5.2. Test configuration

EUT was placed on a urethane platform of nominal size, 1.0 m by 1.5 m, raised 0.8 m above the conducting ground plane.

The EUT was set on the edge of the tabletop.

Test was made with the antenna positioned in both the horizontal and vertical planes of polarization. The measurement antenna was varied in height above the conducting ground plane to obtain the maximum signal strength.

Photographs of the set up are shown in Appendix 3.

5.3. Test conditions

Frequency range : 30 MHz - 200 MHz (Biconical antenna) / 200 MHz - 1000 MHz (Logperiodic antenna)
1000 MHz - 2000 MHz (Horn antenna)
Test distance : 3 m
EUT position : Table top
EUT operation mode : See Clause 4.1

5.4. Test procedure

The height of the measuring antenna varied between 1 and 4 m and EUT was rotated a full revolution in order to obtain the maximum value of the electric field intensity.

The measurements were performed for both vertical and horizontal antenna polarization with the Test Receiver.

The radiated emission measurements were made with the following detector function of the Test Receiver.

Frequency	Below 1GHz	Above 1GHz *1)
Instrument used	Test Receiver	Test Receiver
IF Bandwidth	QP: BW 120 kHz	PK: BW 1 MHz, CISPR AV: BW 1 MHz

*1) The measurement data was adjusted to a 3 m distance using the following Distance Factor.

Distance Factor: $20 \times \log(3.3 \text{ m} / 3 \text{ m}) = 0.83 \text{ dB}$

Figure 2: Test Setup

Below 1 GHz

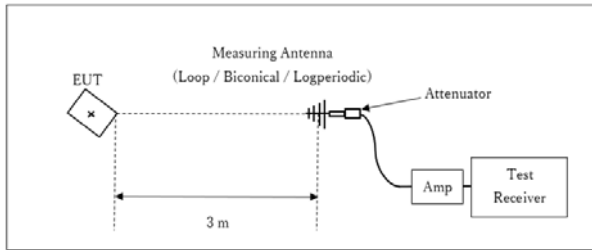

× : Center of turn table

Test Distance: 3 m

1 GHz - 2 GHz

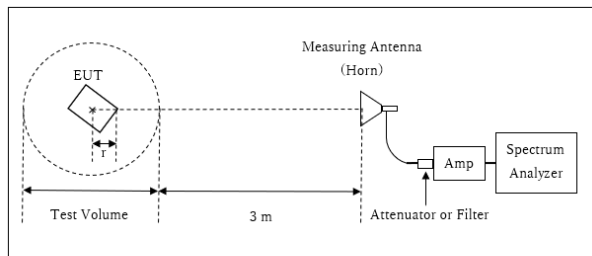

r : Radius of an outer periphery of EUT
× : Center of turn table

Distance Factor: $20 \times \log(3.3 \text{ m}^*/3.0 \text{ m}) = 0.83 \text{ dB}$

* Test Distance: $(3 + \text{Test Volume} / 2) - r = 3.3 \text{ m}$

Test Volume: 2 m

(Test Volume has been calibrated based on CISPR 16-1-4.)

$r = 0.7 \text{ m}$

- The noise levels were confirmed at each position of X, Y and Z axes of EUT to see the position of maximum noise, and the test was made at the position that has the maximum noise.

5.5. Test result

Summary of the test results: Pass

The limit is rounded down to one decimal place.

The test result is rounded off to one or two decimal places, so some differences might be observed.

Date: March 20, 2019 (Day)
March 20, 2019 (Night)

Test engineer: Koji Yamamoto
Akihiko Maeda

APPENDIX 1: Test data

Radiated emission

Report No. 12742873H
Test place Ise EMC Lab.
Semi Anechoic Chamber No.4
Date March 20, 2019
Temperature / Humidity 21 deg. C / 35 % RH
Engineer Koji Yamamoto
(Below 1 GHz)
Mode Mode 1

Limit : FCC_Part 15 Subpart B(15.109)_Class B

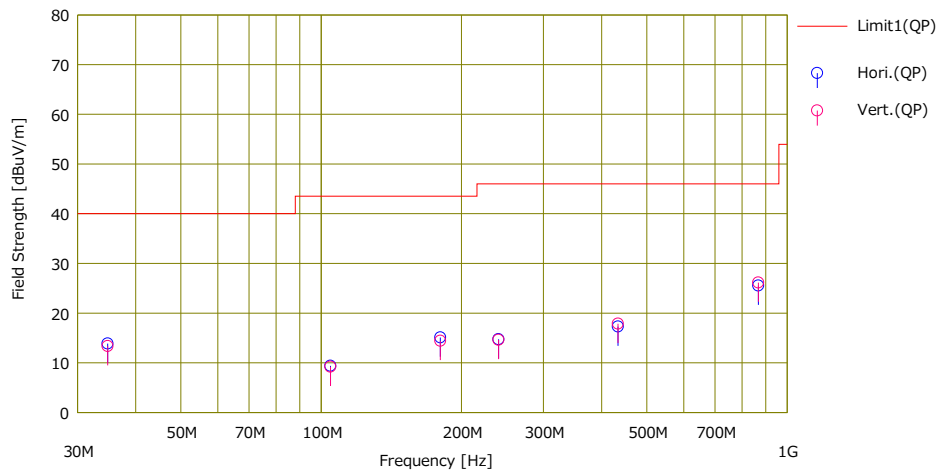

No.	Freq. [MHz]	Reading	Ant.Fac [dB/m]	Loss [dB]	Gain [dB]	Result	Limit	Margin	Pola. [H/V]	Height [cm]	Angle [deg]	Ant. Type	Comment
		[dBuV]				[QP]	[QP]	[QP]					
1	34.825	22.19	16.59	7.28	32.20	13.86	40.00	26.14	Hori.	300	138	BC	
2	104.705	22.35	10.88	8.25	32.11	9.37	43.50	34.13	Hori.	300	359	BC	
3	180.234	21.87	16.25	9.00	32.01	15.11	43.50	28.39	Hori.	300	174	BC	
4	240.305	25.63	11.56	9.50	31.96	14.73	46.00	31.27	Hori.	100	6	LA23	
5	433.670	21.98	16.44	10.82	31.96	17.28	46.00	28.72	Hori.	100	46	LA23	
6	867.340	21.76	21.99	13.06	31.29	25.52	46.00	20.48	Hori.	100	353	LA23	
7	34.825	21.68	16.59	7.28	32.20	13.35	40.00	26.65	Vert.	100	203	BC	
8	104.705	22.18	10.88	8.25	32.11	9.20	43.50	34.30	Vert.	100	2	BC	
9	180.234	21.19	16.25	9.00	32.01	14.43	43.50	29.07	Vert.	100	168	BC	
10	240.305	25.52	11.56	9.50	31.96	14.62	46.00	31.38	Vert.	100	204	LA23	
11	433.670	22.56	16.44	10.82	31.96	17.86	46.00	28.14	Vert.	100	62	LA23	
12	867.340	22.38	21.99	13.06	31.29	26.14	46.00	19.86	Vert.	100	150	LA23	

CHART: WITH FACTOR

ANT TYPE: - 30 MHz: LOOP, 30 MHz - 200 MHz: BICONICAL, 200 MHz - 1000 MHz: LOGPERIODIC, 1000 MHz -: HORN

CALCULATION: RESULT = READING + ANT FACTOR + LOSS & GAIN (CABLE - GAIN(AMP))

UL Japan, Inc.

Ise EMC Lab.

4383-326 Asama-cho, Ise-shi, Mie-ken 516-0021 JAPAN

Telephone : +81 596 24 8999

Facsimile : +81 596 24 8124

Radiated emission

Report No. 12742873H
Test place Ise EMC Lab.
Semi Anechoic Chamber No.4
Date March 20, 2019
Temperature / Humidity 20 deg. C / 38 % RH
Engineer Akihiko Maeda
(Above 1 GHz)
Mode Mode 1

Limit : FCC_Part 15 Subpart B(15.109)_Class B

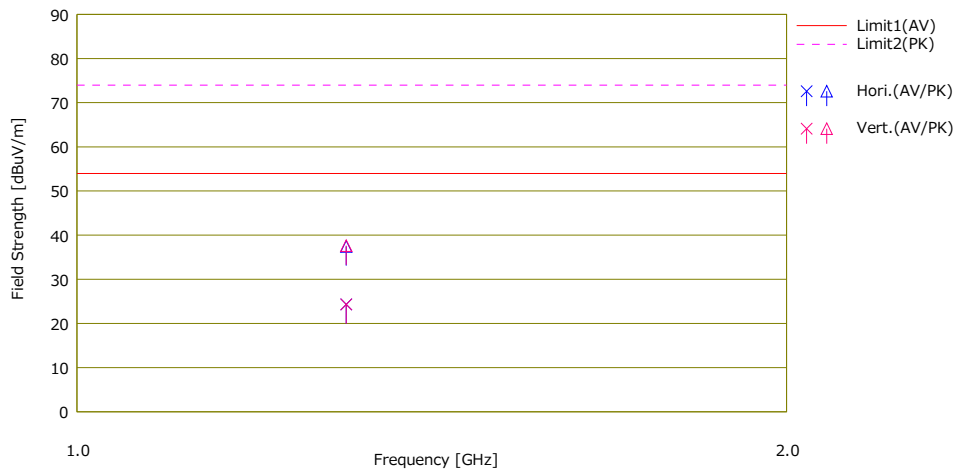

No.	Freq. [MHz]	Reading		Ant.Fac [dB/m]	Loss [dB]	Gain [dB]	Result		Limit		Margin		Pda [H/V]	Height [cm]	Angle [deg]	Ant. Type	Comment
		(AV) [dBuV]	(PK) [dBuV]				(AV) [dBuV/m]	(PK) [dBuV/m]	(AV) [dBuV/m]	(PK) [dBuV/m]	(AV) [dB]	(PK) [dB]					
1	1301.010	29.50	42.60	25.37	2.76	33.30	24.33	37.43	54.00	74.00	29.67	36.57	Hori.	100	0	H21	
2	1301.010	29.50	42.80	25.37	2.76	33.30	24.33	37.63	54.00	74.00	29.67	36.37	Vert.	100	0	H21	

CHART: WITH FACTOR

ANT TYPE: - 30 MHz: LOOP, 30 MHz - 200 MHz: BICONICAL, 200 MHz - 1000 MHz: LOGPERIODIC, 1000 MHz -: HORN

CALCULATION: RESULT = READING + ANT FACTOR + LOSS & GAIN (CABLE - GAIN(AMP))

UL Japan, Inc.

Ise EMC Lab.

4383-326 Asama-cho, Ise-shi, Mie-ken 516-0021 JAPAN

Telephone : +81 596 24 8999

Facsimile : +81 596 24 8124

APPENDIX 2: Test instruments

Test Instruments

Test item	LIMS ID	Description	Manufacturer	Model	Serial	Last Calibration Date	Calibration Due Date	Cal Int
RE	142011	AC4_Semi Anechoic Chamber(NSA)	TDK	Semi Anechoic Chamber 3m	DA-10005	2018/6/28	2020/6/30	24
RE	148898	Attenuator	KEYSIGHT	8491A	MY52462282	2018/10/3	2019/10/31	12
RE	142227	Measure	KOMELON	KMC-36	-	-	-	-
RE	141152	EMI measurement program	TSJ	TEPTO-DV	-	-	-	-
RE	141949	Test Receiver	Rohde & Schwarz	ESCI	100767	2018/8/6	2019/8/31	12
RE	141425	Biconical Antenna	Schwarzbeck	BBA9106	1302	2018/6/1	2019/6/30	12
RE	141267	Logperiodic Antenna(200-1000MHz)	Schwarzbeck	VUSLP9111B	911B-192	2018/6/1	2019/6/30	12
RE	141397	Coaxial Cable	UL Japan	-	-	2018/6/13	2019/6/30	12
RE	141583	Pre Amplifier	SONOMA INSTRUMENT	310	260833	2019/2/8	2020/2/29	12
RE	141545	DIGITAL HiTESTER	HIOKI	3805	51201148	2019/1/29	2020/1/31	12
RE	141562	Thermo-Hygrometer	CUSTOM	CTH-201	10	2019/1/11	2020/1/31	12
RE	141412	Microwave Cable	Junkosha	MWX221	1305S002R(1m) / 1405S146(5m)	2018/6/14	2019/6/30	12
RE	141581	MicroWave System Amplifier	AGILENT	83017A	650	2018/10/4	2019/10/31	12
RE	141901	Spectrum Analyzer	AGILENT	E4440A	MY48250080	2018/10/4	2019/10/31	12
RE	141508	Horn Antenna 1-18GHz	Schwarzbeck	BBHA9120D	9120D-557	2018/6/8	2019/6/30	12
RE	142017	AC4_Semi Anechoic Chamber(SVSWR)	TDK	Semi Anechoic Chamber 3m	DA-10005	2018/4/20	2019/4/30	12

*Hyphens for Last Calibration Date, Calibration Due Date and Cal Int (month) are instruments that Calibration is not required (e.g. software), or instruments checked in advance before use.

The expiration date of the calibration is the end of the expired month.

All equipment is calibrated with valid calibrations. Each measurement data is traceable to the national or international standards.

As for some calibrations performed after the tested dates, those test equipment have been controlled by means of an unbroken chains of calibrations.

Test item:

RE: Radiated emission

UL Japan, Inc.

Ise EMC Lab.

4383-326 Asama-cho, Ise-shi, Mie-ken 516-0021 JAPAN

Telephone : +81 596 24 8999

Facsimile : +81 596 24 8124