

FCC TEST REPORT

Product Name : Wireless Mouse
Trade mark : TeckNet or TECKNET
Model No. : EWM01107, EWM01769
Report Number : BLA-EMC-202010-A5801
FCCID : 2AK8Q-EWM011073
Date of sample receipt : 2020/10/27
Date of Test : 2020/10/27 to 2020/12/1
Date of Issue : 2020/12/1
Test Standards : FCC CFR Title 47 Part 15 Subpart C
Section 15.249
Test result : PASS

Prepared for:

Shenzhen Unichain Technology Co., Ltd

**201, 2nd Floor, Building C, Shanhai Commercial Plaza, Huangjunshan District,
Bantian Street, Longgang District, Shenzhen, China**

Prepared by:

**BlueAsia of Technical Services(Shenzhen) Co.,Ltd.
IOT Test Centre of BlueAsia**

**No. 448 Bulong Road, Bantian Street, Longgang District,
Shenzhen,China**

TEL: +86-755-23059481

Compiled by:

Jozu.

Review by:

Sweet. Liang

Approved by:

Imen li

Date:

2020/12/1



Report Revise Record

Version No.	Date	Description
00	2020/12/1	Original

BlueAsia

Contents

	Page
	1
REPORT REVISE RECORD	2
CONTENTS	3
1 TEST SUMMARY	4
2 GENERAL INFORMATION	5
3 GENERAL DESCRIPTION OF E.U.T.	5
4 DESCRIPTION OF TEST	6
5 DESCRIPTION OF SUPPORT UNITS	6
6 TEST ENVIRONMENT AND MODE	6
7 DESCRIPTION OF SUPPORT UNITS	6
7.1 TEST LOCATION	6
7.2 TEST FACILITY	7
7.3 DEVIATION FROM STANDARDS	7
7.4 ABNORMALITIES FROM STANDARD CONDITIONS	7
7.5 OTHER INFORMATION REQUESTED BY THE CUSTOMER	7
7.6 MEASUREMENT UNCERTAINTY (95% CONFIDENCE LEVELS, K=2)	8
8 EQUIPMENT LIST	9
9 TEST RESULTS AND MEASUREMENT DATA	10
9.1 ANTENNA REQUIREMENT	10
9.2 CONDUCTED EMISSIONS	11
9.3 RADIATED EMISSION	12
9.4 RESTRICTED BANDS AROUND FUNDAMENTAL FREQUENCY	23
9.5 20DB BANDWIDTH	29
APPENDIX 1 PHOTOGRAPHS OF TEST SETUP	31
APPENDIX 2 PHOTOGRAPHS OF EUT	32

1 Test Summary

Test Item	Test Requirement	Test method	Result
Antenna Requirement	47 CFR Part 15 Subpart C Section 15.203	ANSI C63.10-2013	PASS
AC Power Line Conducted Emission	47 CFR Part 15 Subpart C Section 15.207	ANSI C63.10-2013	N/A
Field Strength of the Fundamental Signal	47 CFR Part 15 Subpart C Section 15.249 (a)	ANSI C63.10-2013	PASS
Spurious Emissions	47 CFR Part 15 Subpart C Section 15.249 (a)/15.209	ANSI C63.10-2013	PASS
Restricted bands around fundamental frequency (Radiated Emission)	47 CFR Part 15 Subpart C Section 15.249(a)/15.205	ANSI C63.10-2013	PASS
20dB Occupied Bandwidth	47 CFR Part 15 Subpart C Section 15.215 (c)	ANSI C63.10-2013	PASS

Pass: The EUT complies with the essential requirements in the standard.

N/A: Not Applicable

2 General Information

Applicant	Shenzhen Unichain Technology Co., Ltd
Address	201, 2nd Floor, Building C, Shanhai Commercial Plaza, Huangjunshan District, Bantian Street, Longgang District, Shenzhen, China
Manufacturer	Shenzhen Tianjie Electronic CO., Ltd
Address	No.5, Xifa Road, Lin Village, Tangxia Town, Dongguan City, Guangdong Province, P. R. China
Factory	N/A
Address	N/A
Product Name	Wireless Mouse
Test Model No.	EWM01107

3 General Description of E.U.T.

Hardware version:	N/A
Software version:	N/A
Technical Parameter:	
Operating Frequency:	2402 MHz ~ 2480MHz
Device type:	Non-specific short range devices
Channel separation:	≥2MHz
Channel number:	40
Modulation:	GFSK
Antenna Type:	Printed Antenna
Antenna Gain	-1.52dBi(Provided by the customer)
Power supply:	DC3.0V

4 Description of test

Operation Frequency each of channel					
Channel	Frequency	Channel	Frequency	Channel	Frequency
1CH	2402 MHz	15CH	2430 MHz	29CH	2458 MHz
2CH	2404 MHz	16CH	2432 MHz	30CH	2460 MHz
3CH	2406 MHz	17CH	2434 MHz	31CH	2462 MHz
4CH	2408 MHz	18CH	2436 MHz	32CH	2464 MHz
5CH	2410MHz	19CH	2438 MHz	33CH	2466 MHz
6CH	2412 MHz	20CH	2440 MHz	34CH	2468 MHz
7CH	2414 MHz	21CH	2442 MHz	35CH	2470 MHz
8CH	2416 MHz	22CH	2444 MHz	36CH	2472 MHz
9CH	2418 MHz	23CH	2446 MHz	37CH	2474 MHz
10CH	2420 MHz	24CH	2448 MHz	38CH	2476 MHz
11CH	2422 MHz	25CH	2450 MHz	39CH	2478 MHz
12CH	2424 MHz	26CH	2452 MHz	40CH	2480 MHz
13CH	2426 MHz	27CH	2454 MHz		
14CH	2428 MHz	28CH	2456 MHz		

5 Description of Support Units

The EUT has been tested independently.

6 Test Environment and Mode

Operating Environment:	
Temperature:	24.0 °C
Humidity:	52 % RH
Atmospheric Pressure:	1008 mbar
Test mode:	
Transmitting mode:	Keep the EUT in transmitting mode with modulation.(new battery is used)

7 Description of Support Units

The EUT has been tested independently and or

The EUT has been tested with associated equipment below.

1) support equipment

Description	Manufacturer	Model No.	Serial Number	Supplied by
Notebook computer	Lenovo	E470C	PF-10FB5C	/
/	/	/	/	/

2) cable

Cable No.	Description	Manufacturer	Cable Type/Length	Supplied by
/	/	/	/	/

7.1 Test Location

BlueAsia of Technical Services(Shenzhen) Co.,Ltd. Tel: +86-755-23059481 Email: marketing@cblueasia.com

All tests were performed at:

BlueAsia of Technical Services(Shenzhen) Co., Ltd.

IOT Test Centre of BlueAsia

No. 448 Bulong Road, Bantian Street, Longgang District, Shenzhen, China

Telephone: TEL: +86-755-28682673 FAX: +86-755-28682673

No tests were sub-contracted.

7.2 Test Facility

The test facility is recognized, certified, or accredited by the following organizations:

FCC — Designation No.: CN1252

BlueAsia of Technical Services(Shenzhen) Co., Ltd has been registered and fully described in a report filed with the (FCC) Federal Communications Commission. The acceptance letter from the FCC is maintained in files. Designation CN1252.

ISED — CAB identifier No.: CN0028

BlueAsia of Technical Services(Shenzhen) Co., Ltd has been registered by Certification and Engineering Bureau of ISED for radio equipment testing with CAB identifier CN0028

7.3 Deviation from Standards

None.

7.4 Abnormalities from Standard Conditions

None.

7.5 Other Information Requested by the Customer

None.

7.6 Measurement Uncertainty (95% confidence levels, k=2)

Test Item	Frequency Range	Measurement Uncertainty	Notes
Radiated Emission	9kHz ~ 30MHz	$\pm 4.34\text{dB}$	(1)
Radiated Emission	30MHz ~ 1000MHz	$\pm 4.24\text{dB}$	(1)
Radiated Emission	1GHz ~ 26.5GHz	$\pm 4.68\text{dB}$	(1)
AC Power Line Conducted Emission	0.15MHz ~ 30MHz	$\pm 3.45\text{dB}$	(1)

Note (1): The measurement uncertainty is for coverage factor of k=2 and a level of confidence of 95%.

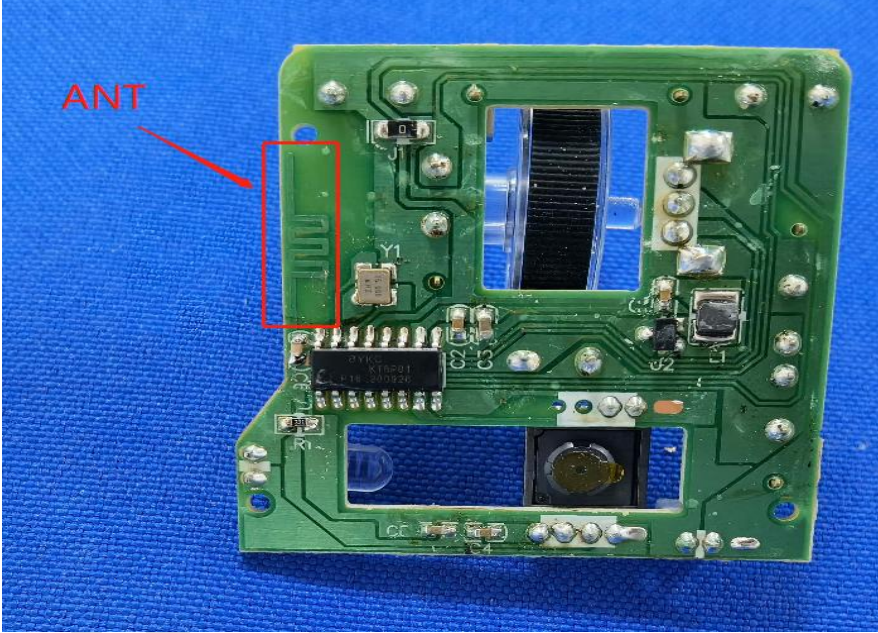
8 Equipment List

Radiated Emission:						
Item	Test Equipment	Manufacturer	Model No.	Serial No.	Cal.Date (mm-dd-yy)	Cal.Due date (mm-dd-yy)
1	3m SAC	SKET	9m*6 m*6m	966	06-10-2018	06-09-2023
2	Broadband Antenna	SCHWARZBECK	VULB9168	00836 P:00227	07-14-2019	07-13-2021
3	Horn Antenna	SCHWARZBECK	9120D	01892 P:00331	07-14-2019	07-13-2021
4	EMI Test Software	EZ	EZ	N/A	N/A	N/A
5	Pre-amplifier	SKET	N/A	N/A	07-19-2020	07-18-2021
6	Spectrum analyzer	Rohde & Schwarz	FSP40	100817	05-24-2020	05-23-2021
7	EMI Test Receiver	Rohde & Schwarz	ESR7	101199	03-21-2020	03-20-2021
8	Controller	SKET	N/A	N/A	N/A	N/A
9	Vector Signal Generator	Agilent	E4438C	MY45092582	05-24-2020	05-23-2021
10	Signal Generator	Agilent	E8257D	MY44320250	05-24-2020	05-23-2021
11	Coaxial Cable	BlueAsia	BLA-XC-02	N/A	N/A	N/A
12	Coaxial Cable	BlueAsia	BLA-XC-03	N/A	N/A	N/A
13	Coaxial Cable	BlueAsia	BLA-XC-01	N/A	N/A	N/A

Conducted Emission						
Item	Test Equipment	Manufacturer	Model No.	Serial No.	Cal.Date (mm-dd-yy)	Cal.Due date (mm-dd-yy)
1	EMI Test Receiver	Rohde & Schwarz	ESPI3	101082	06-10-2020	06-09-2021
2	LISN	CHASE	MN2050D	1447	12-18-2019	12-17-2020
3	LISN	Rohde & Schwarz	ENV216	3560.6550.15	07-19-2020	07-18-2021
4	EMI Test Software	EZ	EZ	N/A	N/A	N/A
5	Temperature Humidity Chamber	Mingle	TH101B	N/A	07-19-2020	07-18-2021
6	Coaxial Cable	BlueAsia	BLA-XC-05	N/A	N/A	N/A

9 Test results and Measurement Data

9.1 Antenna Requirement

Standard requirement:	47 CFR Part 15C Section 15.203
<p>15.203 requirement: An intentional radiator shall be designed to ensure that no antenna other than that furnished by the responsible party shall be used with the device. The use of a permanently attached antenna or of an antenna that uses a unique coupling to the intentional radiator, the manufacturer may design the unit so that a broken antenna can be replaced by the user, but the use of a standard antenna jack or electrical connector is prohibited.</p>	
<p>EUT Antenna:</p>	
<p>The antenna is integrated on the main PCB and no consideration of replacement. The best case gain of the antenna is -1.52dBi.</p>	

9.2 Conducted Emissions

Test Requirement: 47 CFR Part 15C Section 15.207
Test Method: ANSI C63.10
Test Frequency Range: 150KHz to 30MHz

Limit:

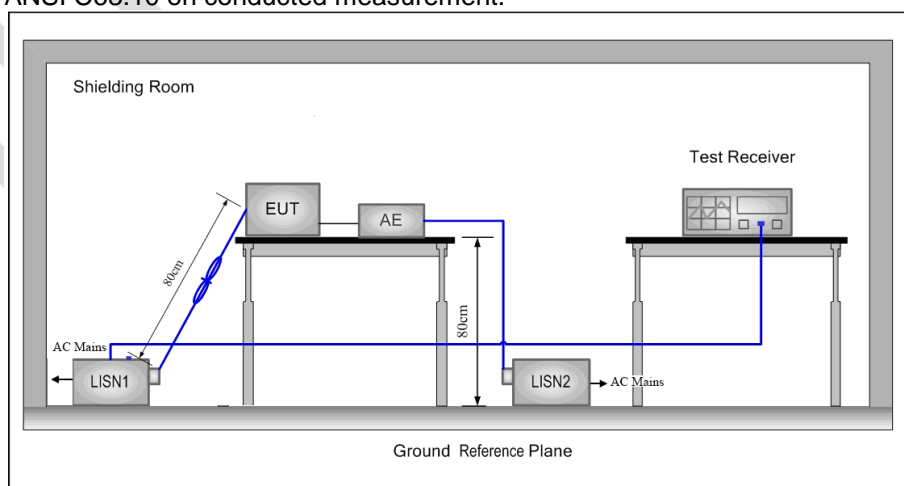
Frequency range (MHz)	Limit (dB μ V)	
	Quasi-peak	Average
0.15-0.5	66 to 56*	56 to 46*
0.5-5	56	46
5-30	60	50

* Decreases with the logarithm of the frequency.

Test Procedure:

- 1) The mains terminal disturbance voltage test was conducted in a shielded room.
- 2) The EUT was connected to AC power source through a LISN 1 (Line Impedance Stabilization Network) which provides a $50\Omega/50\mu\text{H} + 5\Omega$ linear impedance. The power cables of all other units of the EUT were connected to a second LISN 2, which was bonded to the ground reference plane in the same way as the LISN 1 for the unit being measured. A multiple socket outlet strip was used to connect multiple power cables to a single LISN provided the rating of the LISN was not exceeded.
- 3) The tabletop EUT was placed upon a non-metallic table 0.8m above the ground reference plane. And for floor-standing arrangement, the EUT was placed on the horizontal ground reference plane,
- 4) The test was performed with a vertical ground reference plane. The rear of the EUT shall be 0,4 m from the vertical ground reference plane. The vertical ground reference plane was bonded to the horizontal ground reference plane. The LISN 1 was placed 0,8 m from the boundary of the unit under test and bonded to a ground reference plane for LISNs mounted on top of the ground reference plane. This distance was between the closest points of the LISN 1 and the EUT. All other units of the EUT and associated equipment was at least 0,8 m from the LISN 2.
- 5) In order to find the maximum emission, the relative positions of equipment and all of the interface cables must be changed according to ANSI C63.10 on conducted measurement.

Test Setup:



Test Mode: Keep the EUT in transmitting mode
Instruments Used: Refer to section 5.11 for details
Test Results: N/A

9.3 Radiated Emission

Test Requirement:	47 CFR Part 15C Section 15.249 and 15.209				
Test Method:	ANSI C63.10				
Test Site:	Measurement Distance: 3m (Semi-Anechoic Chamber)				
Receiver Setup:	Frequency	Detector	RBW	VBW	Remark
	0.009MHz-0.090MHz	Peak	10kHz	30KHz	Peak
	0.009MHz-0.090MHz	Average	10kHz	30KHz	Average
	0.090MHz-0.110MHz	Quasi-peak	10kHz	30KHz	Quasi-peak
	0.110MHz-0.490MHz	Peak	10kHz	30KHz	Peak
	0.110MHz-0.490MHz	Average	10kHz	30KHz	Average
	0.490MHz -30MHz	Quasi-peak	10kHz	30kHz	Quasi-peak
	30MHz-1GHz	Quasi-peak	120 kHz	300KHz	Quasi-peak
	Above 1GHz	Peak	1MHz	3MHz	Peak
Peak		1MHz	10Hz	Average	

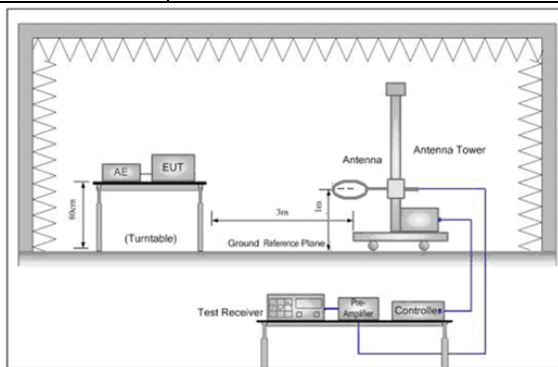
Test Setup:


Figure 1. Below 30MHz

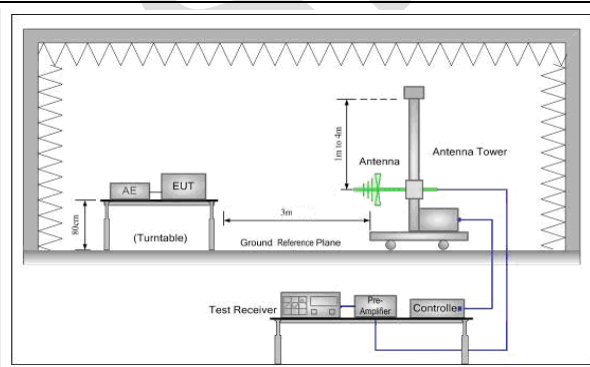


Figure 2. 30MHz to 1GHz

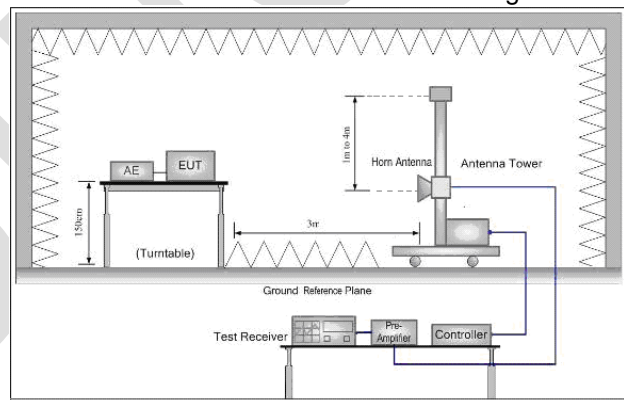


Figure 3. Above 1GHz

Test Procedure:
Below 1GHz test procedure as below:

The EUT was placed on the top of a rotating table 0.8 meters above the ground at a 3 meter semi-anechoic chamber. The table was rotated 360 degrees to determine the position of the highest radiation.

The EUT was set 3 meters away from the interference-receiving antenna, which was mounted on the top of a variable-height antenna tower.

The antenna height is varied from one meter to four meters above the ground to determine the maximum value of the field strength. Both horizontal and vertical polarizations of the antenna are set to make the measurement.

For each suspected emission, the EUT was arranged to its worst case and then the antenna was tuned to heights from 1 meter to 4 meters (for the test frequency of below

	<p>30MHz, the antenna was tuned to heights 1 meter) and the rota table table was turned from 0 degrees to 360 degrees to find the maximum reading. The test-receiver system was set to Peak Detect Function and Specified Bandwidth with Maximum Hold Mode. If the emission level of the EUT in peak mode was 10dB lower than the limit specified, then testing could be stopped and the peak values of the EUT would be reported. Otherwise the emissions that did not have 10dB margin would be re-tested one by one using peak, quasi-peak or average method as specified and then reported in a data sheet. Above 1GHz test procedure as below: Different between above is the test site, change from Semi- Anechoic Chamber to fully Anechoic Chamber and change form table 0.8 meter to 1.5 meter. Test the EUT in the lowest channel ,middle channel, the Highest channel The radiation measurements are performed in X, Y, Z axis positioning for Transmitting mode, and found the X axis positioning which it is worse case. Repeat above procedures until all frequencies measured was complete.</p>																																																	
Limit: (Spurious Emissions)	<table border="1" data-bbox="443 734 1493 1182"> <thead> <tr> <th>Frequency</th> <th>Field strength (microvolt/meter)</th> <th>Limit (dBμV/m)</th> <th>Remark</th> <th>Measurement distance (m)</th> </tr> </thead> <tbody> <tr> <td>0.009MHz-0.490MHz</td> <td>2400/F (kHz)</td> <td>-</td> <td>-</td> <td>300</td> </tr> <tr> <td>0.490MHz-1.705MHz</td> <td>24000/F (kHz)</td> <td>-</td> <td>-</td> <td>30</td> </tr> <tr> <td>1.705MHz-30MHz</td> <td>30</td> <td>-</td> <td>-</td> <td>30</td> </tr> <tr> <td>30MHz-88MHz</td> <td>100</td> <td>40.0</td> <td>Quasi-peak</td> <td>3</td> </tr> <tr> <td>88MHz-216MHz</td> <td>150</td> <td>43.5</td> <td>Quasi-peak</td> <td>3</td> </tr> <tr> <td>216MHz-960MHz</td> <td>200</td> <td>46.0</td> <td>Quasi-peak</td> <td>3</td> </tr> <tr> <td>960MHz-1GHz</td> <td>500</td> <td>54.0</td> <td>Quasi-peak</td> <td>3</td> </tr> <tr> <td>Above 1GHz</td> <td>500</td> <td>54.0</td> <td>Average</td> <td>3</td> </tr> </tbody> </table> <p>Note: 15.35(b), Unless otherwise specified, the limit on peak radio frequency emissions is 20dB above the maximum permitted average emission limit applicable to the equipment under test. This peak limit applies to the total peak emission level radiated by the device.</p>					Frequency	Field strength (microvolt/meter)	Limit (dB μ V/m)	Remark	Measurement distance (m)	0.009MHz-0.490MHz	2400/F (kHz)	-	-	300	0.490MHz-1.705MHz	24000/F (kHz)	-	-	30	1.705MHz-30MHz	30	-	-	30	30MHz-88MHz	100	40.0	Quasi-peak	3	88MHz-216MHz	150	43.5	Quasi-peak	3	216MHz-960MHz	200	46.0	Quasi-peak	3	960MHz-1GHz	500	54.0	Quasi-peak	3	Above 1GHz	500	54.0	Average	3
Frequency	Field strength (microvolt/meter)	Limit (dB μ V/m)	Remark	Measurement distance (m)																																														
0.009MHz-0.490MHz	2400/F (kHz)	-	-	300																																														
0.490MHz-1.705MHz	24000/F (kHz)	-	-	30																																														
1.705MHz-30MHz	30	-	-	30																																														
30MHz-88MHz	100	40.0	Quasi-peak	3																																														
88MHz-216MHz	150	43.5	Quasi-peak	3																																														
216MHz-960MHz	200	46.0	Quasi-peak	3																																														
960MHz-1GHz	500	54.0	Quasi-peak	3																																														
Above 1GHz	500	54.0	Average	3																																														
Limit: (Field strength of the fundamental signal)	<table border="1" data-bbox="443 1330 1493 1458"> <thead> <tr> <th>Frequency</th> <th>Limit (dBμV/m @3m)</th> <th>Remark</th> </tr> </thead> <tbody> <tr> <td rowspan="2">2400MHz-2483.5MHz</td> <td>94.0</td> <td>Average Value</td> </tr> <tr> <td>114.0</td> <td>Peak Value</td> </tr> </tbody> </table>				Frequency	Limit (dB μ V/m @3m)	Remark	2400MHz-2483.5MHz	94.0	Average Value	114.0	Peak Value																																						
Frequency	Limit (dB μ V/m @3m)	Remark																																																
2400MHz-2483.5MHz	94.0	Average Value																																																
	114.0	Peak Value																																																
Instruments Used:	Refer to section 5.11 for details																																																	
Exploratory Test Mode:	Transmitting mode																																																	
Final Test Mode:	Pretest the EUT at Transmitting mode																																																	
Test Results:	Pass																																																	

**Measurement Data
Field Strength Of The Fundamental Signal**

Peak value:

Frequency (MHz)	Reading Level (dBuV)	Correct Factor (dB)	Level (dB μ V/m)	Limit (dB μ V/m)	Over Limit (dB)	Antenna Polaxis
2402	95.51	-13.56	81.95	114.00	-32.05	H
2402	84.28	-13.90	70.38	114.00	-43.62	V
2441	94.89	-13.35	81.54	114.00	-32.46	H
2441	85.44	-13.71	71.73	114.00	-42.27	V
2480	84.25	-13.13	71.12	114.00	-42.88	H
2480	84.64	-13.52	71.12	114.00	-42.88	V

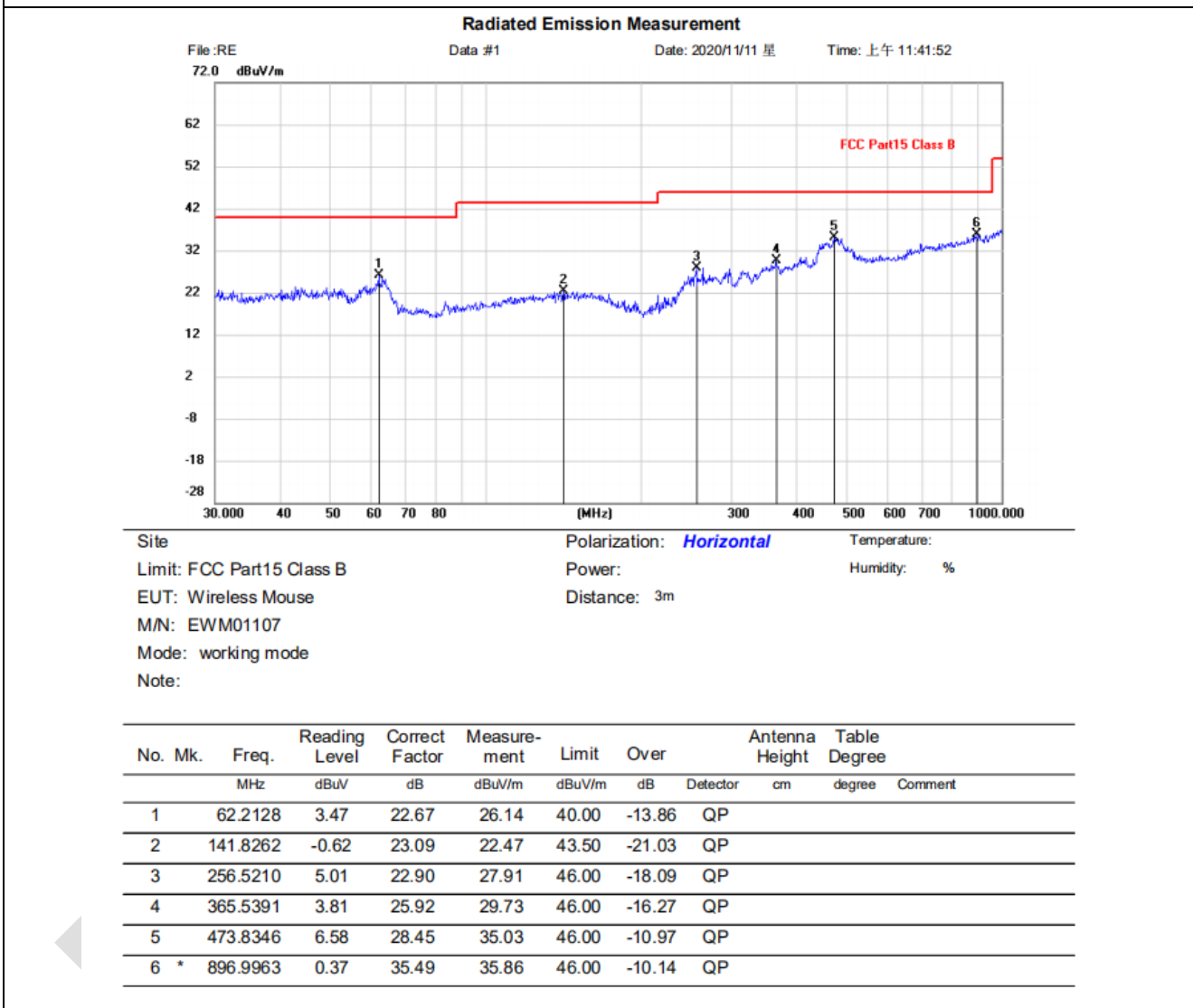
Average value:

Frequency (MHz)	Reading Level (dBuV)	Correct Factor (dB)	Level (dB μ V/m)	Limit (dB μ V/m)	Over Limit (dB)	Antenna Polaxis
2402	89.24	-13.56	75.68	94	-18.32	H
2402	78.46	-13.90	64.56	94	-29.44	V
2441	89.65	-13.35	76.30	94	-17.70	H
2441	80.69	-13.71	66.98	94	-27.02	V
2480	78.41	-13.13	65.28	94	-28.72	H
2480	79.04	-13.52	65.52	94	-28.48	V

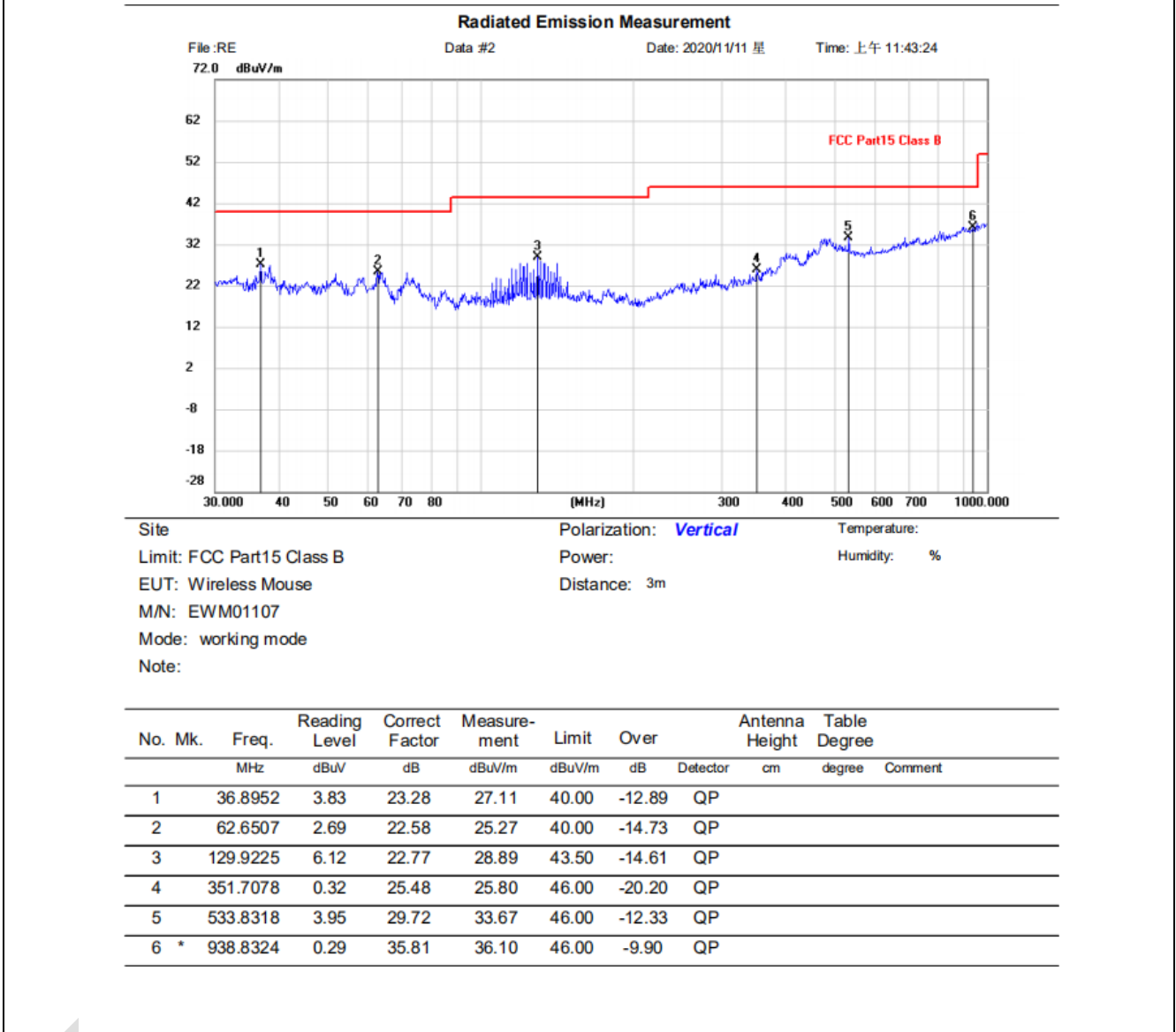
NOTE: RBW 3MHz VBW 10MHz , PK detector is for PK value ,RMS detector is for AV value.

Spurious Emissions
30MHz~1GHz (QP)
Test mode: Transmitting

Horizontal:

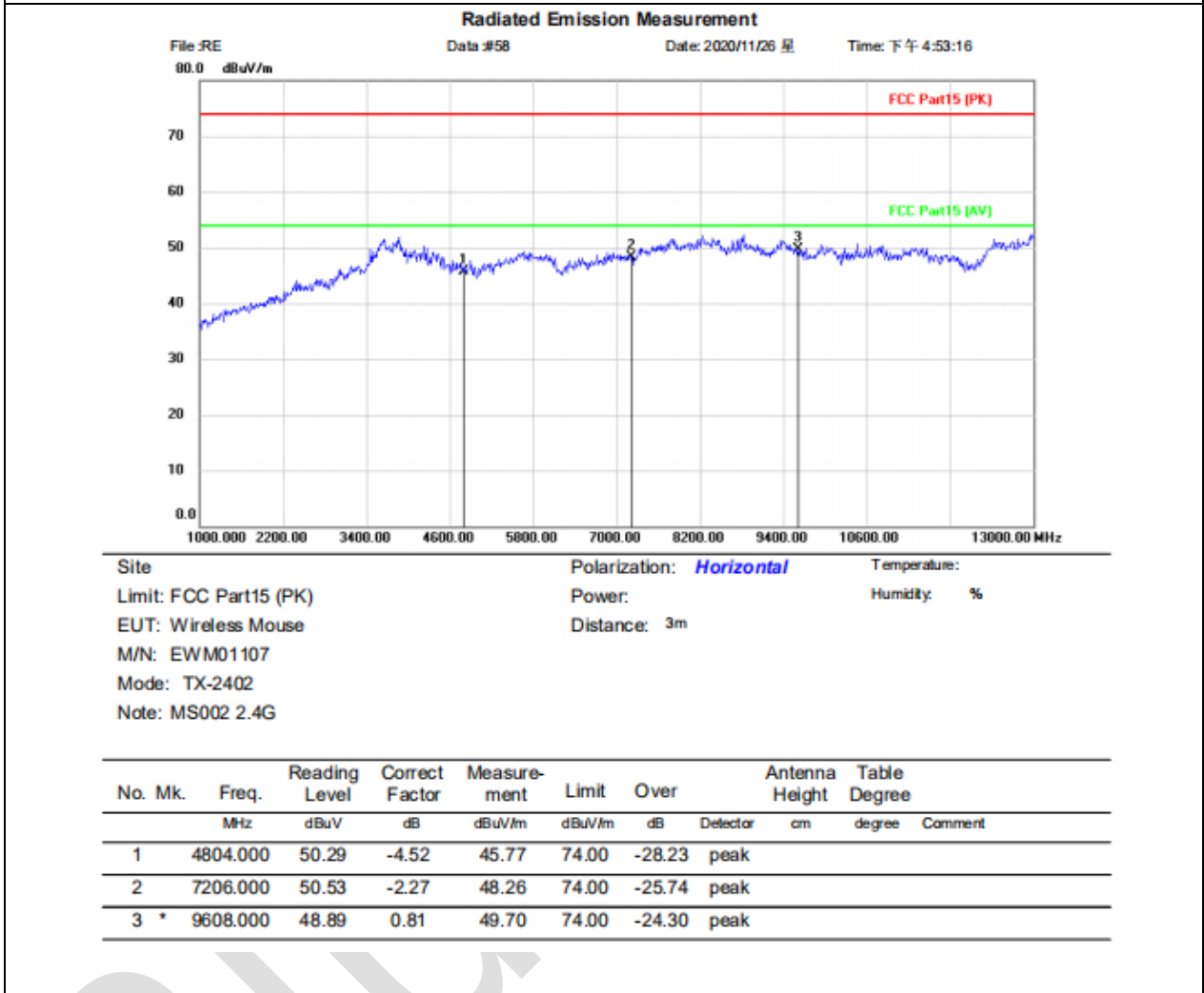


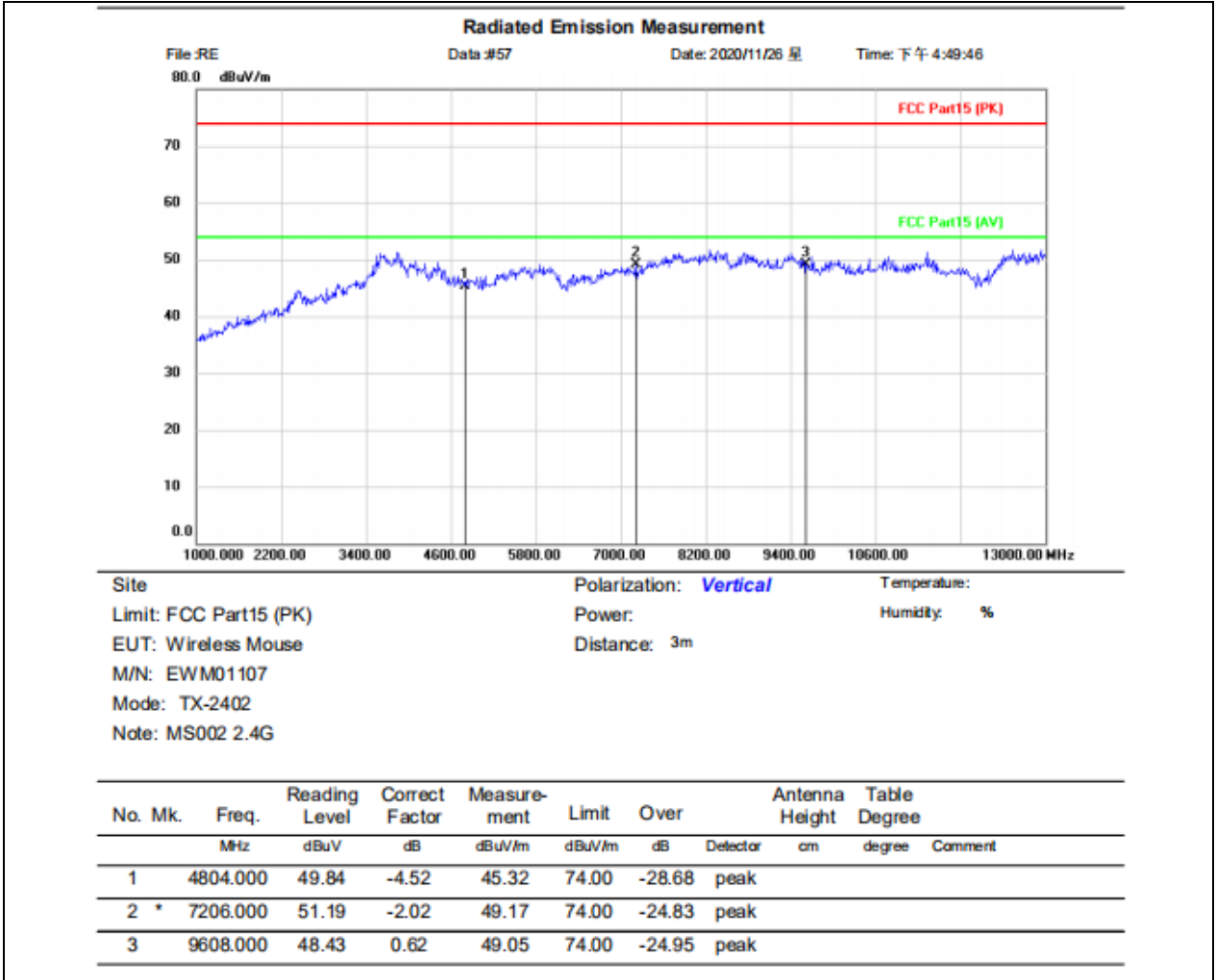
Vertical:

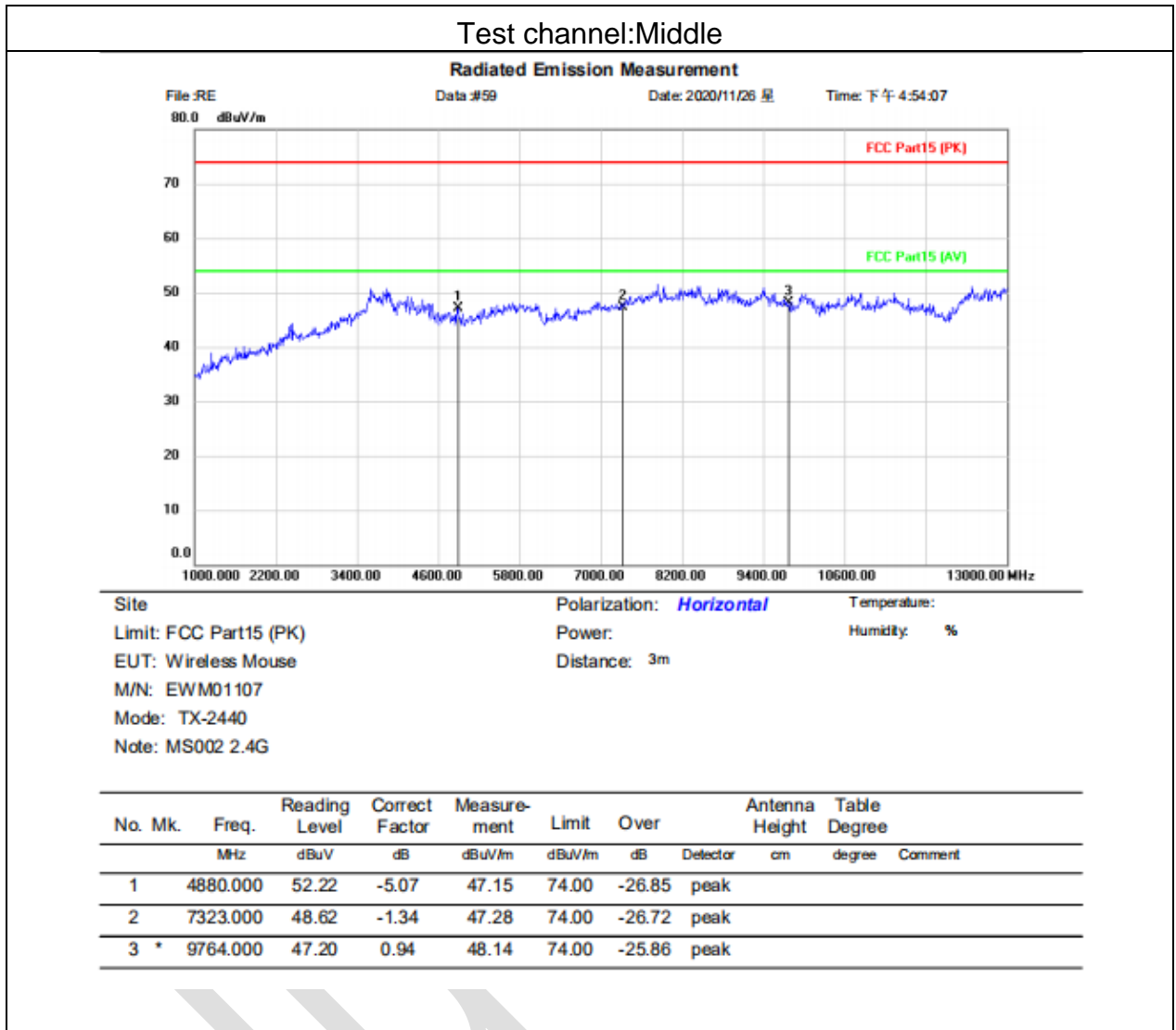


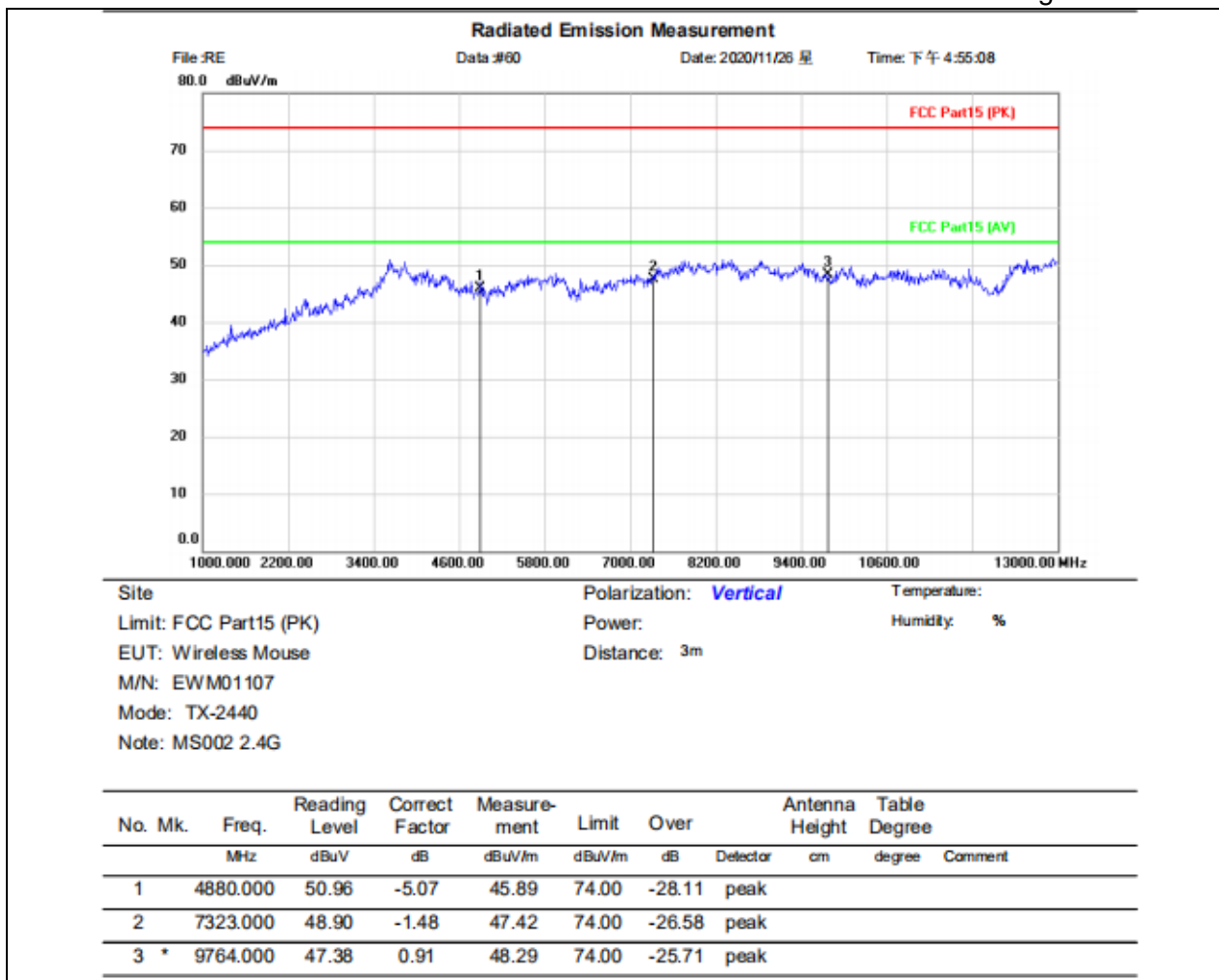
Above 1GHz:

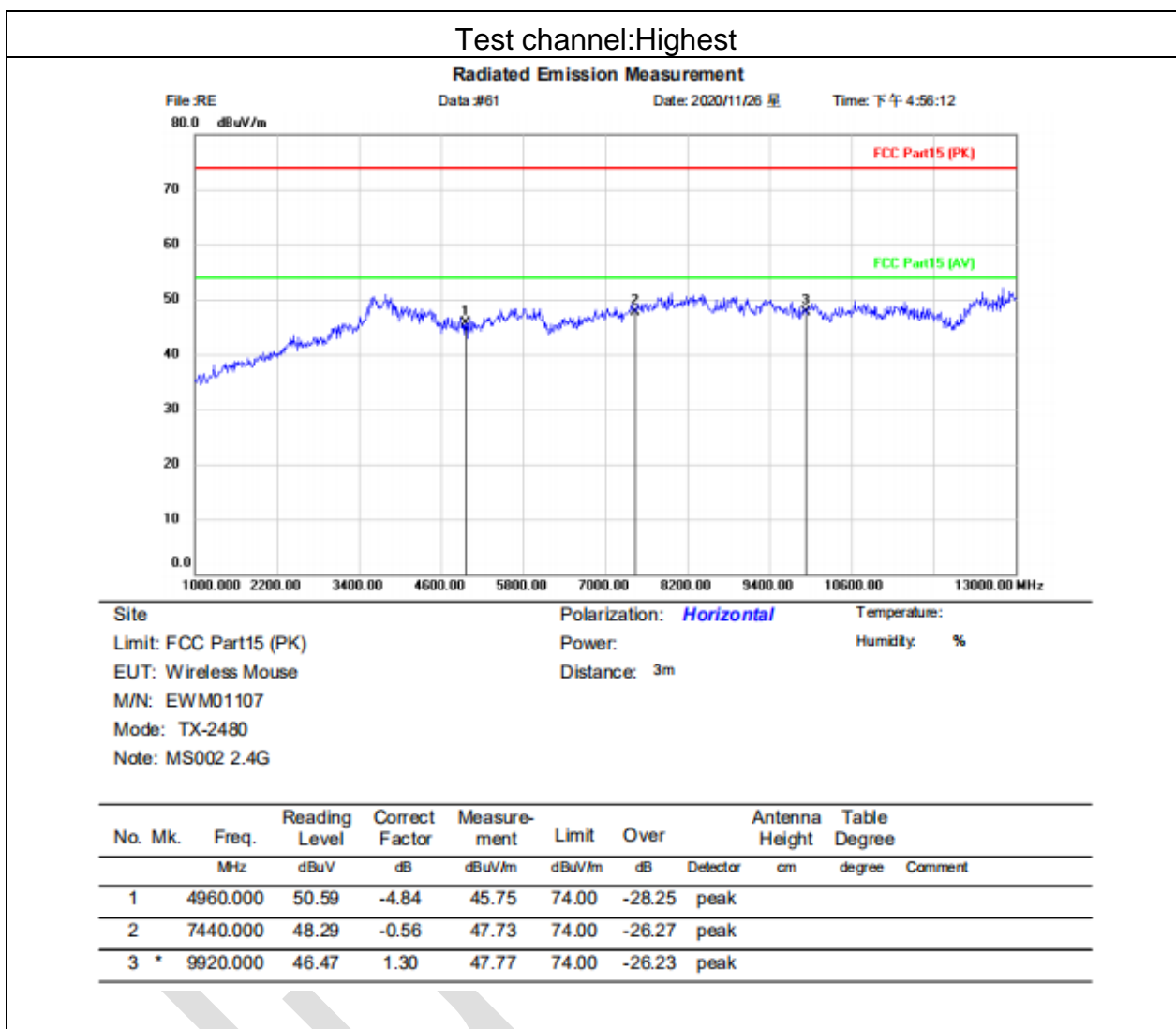
Test channel:lowest

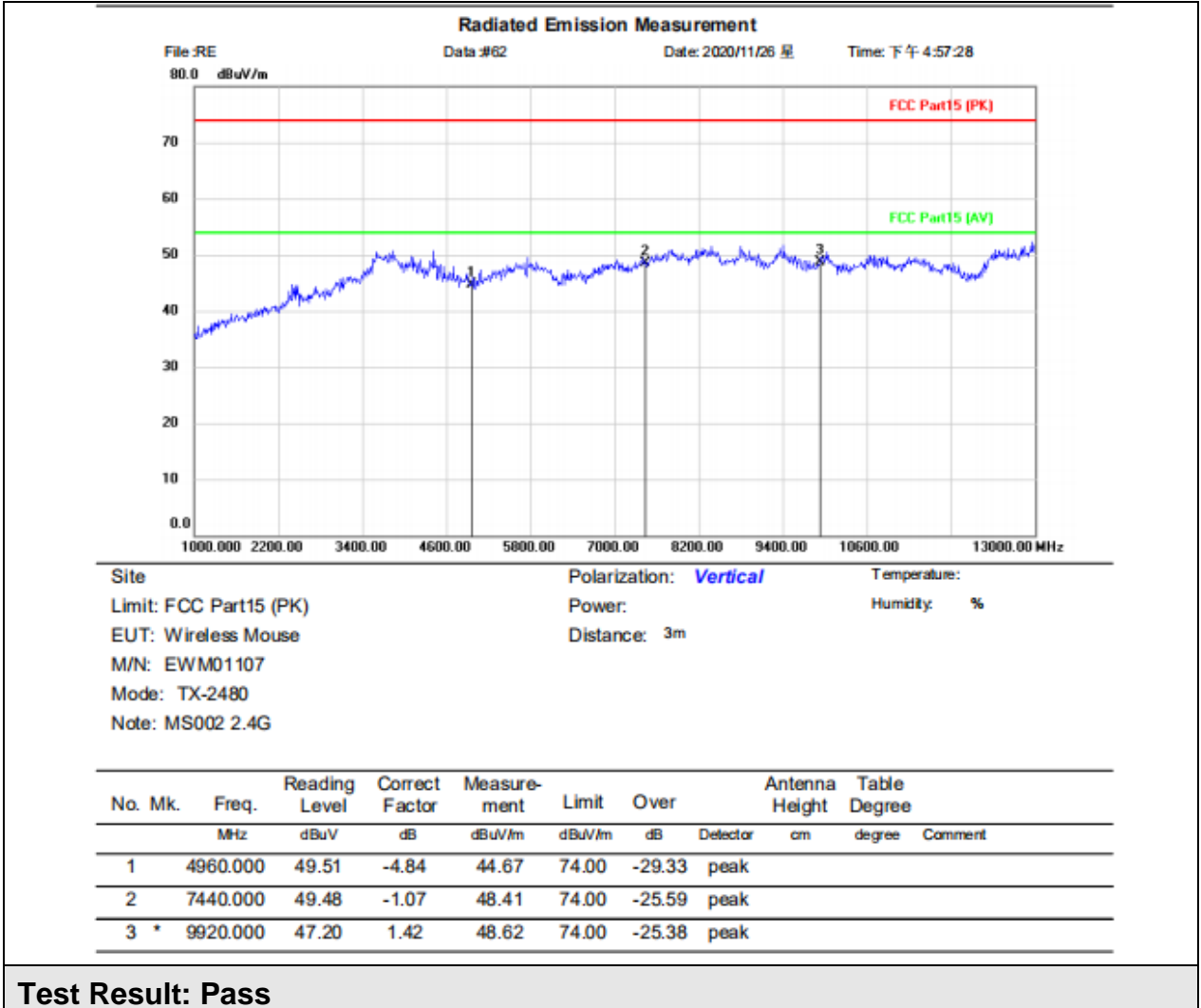











Remark:

- 1) The field strength is calculated by adding the Antenna Factor, Cable Factor & Preamplifier. The basic equation with a sample calculation is as follows:
 $Final\ Test\ Level = Receiver\ Reading + Correct\ Factor$
 $Correct\ Factor = Antenna\ Factor + Cable\ Factor - Preamplifier\ Factor$
- 2) Scan from 9kHz to 25GHz, The disturbance above 13GHz and below 30MHz was very low, and the above harmonics were the highest point could be found when testing, so only the above harmonics had been displayed. The amplitude of spurious emissions from the radiator which are attenuated more than 20dB below the limit need not be reported .
- 3) As shown in this section, for frequencies above 1GHz, the field strength limits are based on average limits. However, the peak field strength of any emission shall not exceed the maximum permitted average limits specified above by more than 20 dB under any condition of modulation. So, only the peak measurements were shown in the report.

9.4 Restricted bands around fundamental frequency

Test Requirement:	47 CFR Part 15C Section 15.209 and 15.205
Test Method:	ANSI C63.10
Test Site:	Measurement Distance: 3m (Semi-Anechoic Chamber)
Test Setup:	

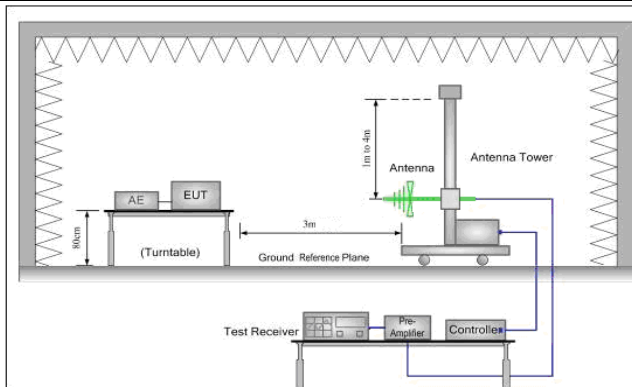


Figure 1. 30MHz to 1GHz

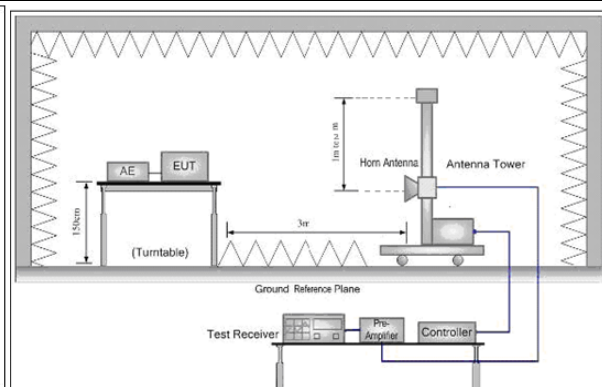


Figure 2. Above 1 GHz

Test Procedure:

Below 1GHz test procedure as below:

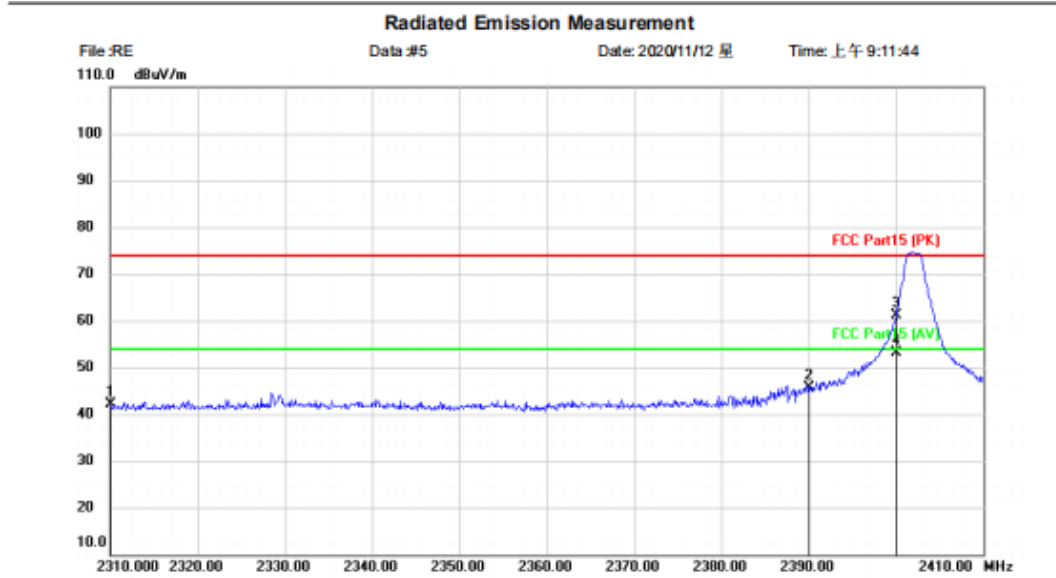
- a. The EUT was placed on the top of a rotating table 0.8 meters above the ground at a 3 meter semi-anechoic chamber. The table was rotated 360 degrees to determine the position of the highest radiation.
- b. The EUT was set 3 meters away from the interference-receiving antenna, which was mounted on the top of a variable-height antenna tower.
- c. The antenna height is varied from one meter to four meters above the ground to determine the maximum value of the field strength. Both horizontal and vertical polarizations of the antenna are set to make the measurement.
- d. For each suspected emission, the EUT was arranged to its worst case and then the antenna was tuned to heights from 1 meter to 4 meters (for the test frequency of below 30MHz, the antenna was tuned to heights 1 meter) and the rotatable table was turned from 0 degrees to 360 degrees to find the maximum reading.
- e. The test-receiver system was set to Peak Detect Function and Specified Bandwidth with Maximum Hold Mode.
- f. If the emission level of the EUT in peak mode was 10dB lower than the limit specified, then testing could be stopped and the peak values of the EUT would be reported. Otherwise the emissions that did not have 10dB margin would be re-tested one by one using peak, quasi-peak or average method as specified and then reported in a data sheet.

Above 1GHz test procedure as below:

- g. Different between above is the test site, change from Semi- Anechoic Chamber to fully Anechoic Chamber and change form table 0.8 meter to 1.5 meter(Above 18GHz the distance is 1 meter and table is 1.5 meter).
- h. Test the EUT in the lowest channel,,the Highest channel
- i. The radiation measurements are performed in X, Y, Z axis positioning for Transmitting mode, and found the X axis positioning which it is worse case.
- j. Repeat above procedures until all frequencies measured was complete.

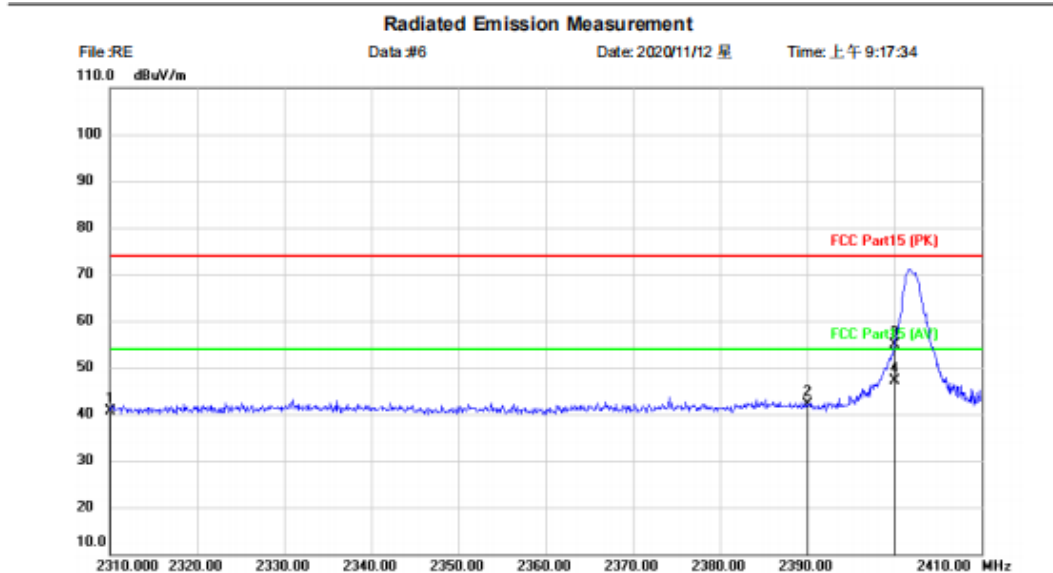
Limit(band edge):	Emissions radiated outside of the specified frequency bands, except for harmonics, shall be attenuated by at least 50 dB below the level of the fundamental or to the general radiated emission limits in Section 15.209, whichever is the lesser attenuation.		
	Frequency	Limit (dB μ V/m @3m)	Remark
	30MHz-88MHz	40.0	Quasi-peak Value
	88MHz-216MHz	43.5	Quasi-peak Value
	216MHz-960MHz	46.0	Quasi-peak Value
	960MHz-1GHz	54.0	Quasi-peak Value
	Above 1GHz	54.0	Average Value
74.0		Peak Value	
Instruments Used:	Refer to section 5.11 for details		
Exploratory Test Mode:	Transmitting mode		
Final Test Mode:	Pretest the EUT at Transmitting mode		
Test Results:	Pass		

Band edge test data (Radiated Emission)

Lowest channel—Horizontal


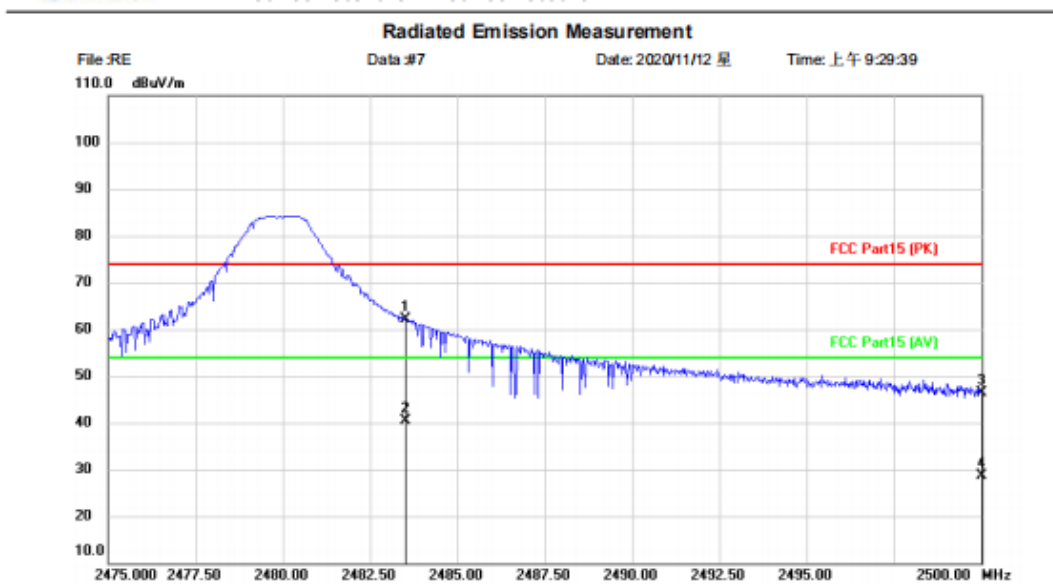
Site	Polarization: Horizontal	Temperature:
Limit: FCC Part15 (PK)	Power:	Humidity: %
EUT: Wireless Mouse	Distance: 3m	
M/N: EWM01107		
Mode: TX-2402		
Note:		

No.	Mk.	Freq.	Reading Level	Correct Factor	Measurement	Limit	Over	Antenna Height	Table Degree	
		MHz	dBuV	dB	dBuV/m	dBuV/m	dB	cm	degree	Comment
1		2310.000	56.04	-14.01	42.03	74.00	-31.97	peak		
2		2390.000	59.25	-13.62	45.63	74.00	-28.37	peak		
3		2400.000	74.65	-13.56	61.09	74.00	-12.91	peak		
4	*	2400.000	66.70	-13.56	53.14	54.00	-0.86	AVG		

Lowest channel—Vertical


Site	Polarization: Vertical	Temperature:
Limit: FCC Part15 (PK)	Power:	Humidity: %
EUT: Wireless Mouse	Distance: 3m	
M/N: EWM01107		
Mode: TX-2402		
Note:		

No.	Mk.	Freq.	Reading Level	Correct Factor	Measurement	Limit	Over	Antenna Height	Table Degree	
		MHz	dBuV	dB	dBuV/m	dBuV/m	dB	cm	degree	Comment
1		2310.000	54.97	-14.30	40.67	74.00	-33.33	peak		
2		2390.000	56.14	-13.95	42.19	74.00	-31.81	peak		
3		2400.000	68.90	-13.90	55.00	74.00	-19.00	peak		
4	*	2400.000	61.11	-13.90	47.21	54.00	-6.79	AVG		

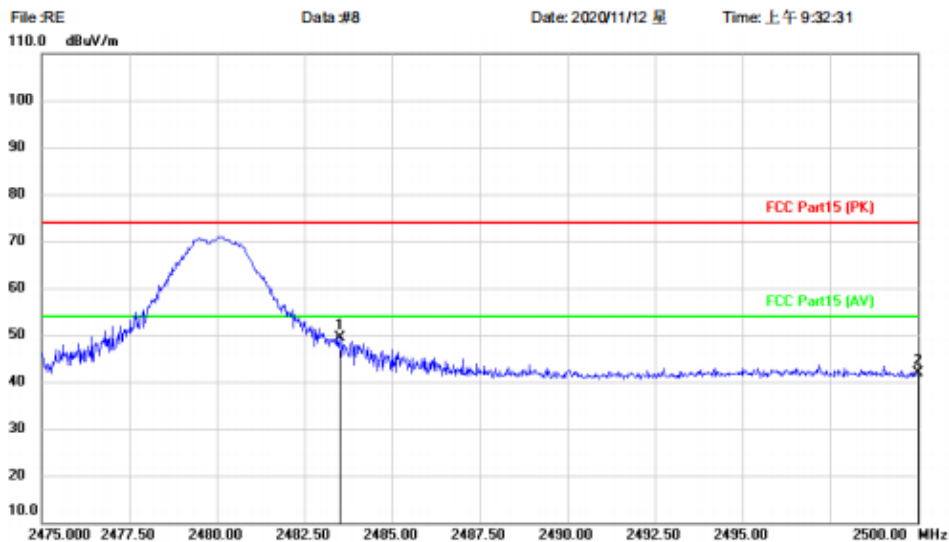
Highest channel-- Horizontal


Site: Polarization: **Horizontal** Temperature:
 Limit: FCC Part15 (PK) Power: Humidity: %
 EUT: Wireless Mouse Distance: 3m
 M/N: EWM01107
 Mode: TX-2480
 Note:

No.	Mk.	Freq.	Reading Level	Correct Factor	Measurement	Limit	Over	Antenna Height	Table Degree	
		MHz	dBuV	dB	dBuV/m	dBuV/m	dB	Detector	cm	degree
1	*	2483.500	75.16	-13.11	62.05	74.00	-11.95	peak		
2		2483.500	53.54	-13.11	40.43	54.00	-13.57	AVG		
3		2500.000	59.39	-13.02	46.37	74.00	-27.63	peak		
4		2500.000	41.54	-13.02	28.52	54.00	-25.48	AVG		

Highest channel-- Vertical

Radiated Emission Measurement



Site	Polarization: Vertical	Temperature:
Limit: FCC Part15 (PK)	Power:	Humidity: %
EUT: Wireless Mouse	Distance: 3m	
M/N: EWM01107		
Mode: TX-2480		
Note:		

No.	Mk.	Freq.	Reading Level	Correct Factor	Measurement	Limit	Over	Antenna Height	Table Degree	
		MHz	dBuV	dB	dBuV/m	dBuV/m	dB	cm	degree	Comment
1	*	2483.500	62.83	-13.50	49.33	74.00	-24.67	peak		
2		2500.000	55.39	-13.42	41.97	74.00	-32.03	peak		

Note:

The field strength is calculated by adding the Antenna Factor, Cable Factor & Preamplifier. The basic equation with a sample calculation is as follows:

$$Final\ Test\ Level = Receiver\ Reading + Correct\ Factor$$

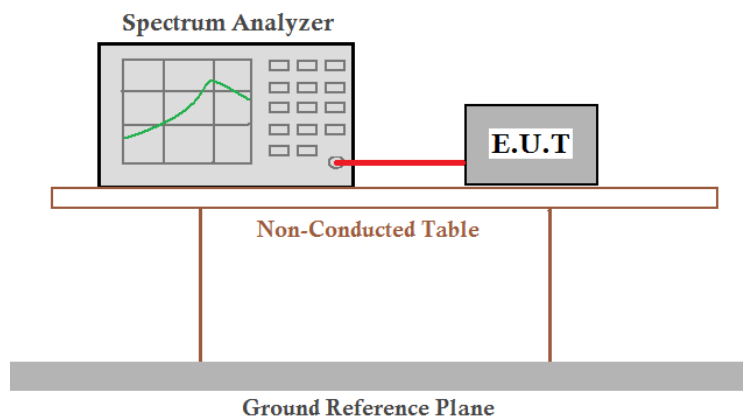
$$Correct\ Factor = Antenna\ Factor + Cable\ Factor - Preamplifier\ Factor$$

9.5 20dB Bandwidth

Test Requirement: 47 CFR Part 15C Section 15.215

Test Method: ANSI C63.10

Test Setup:



Instruments Used: Refer to section 5.11 for details

Exploratory Test Mode: Transmitting mode
Pretest the EUT at Transmitting mode

Final Test Mode:

Limit: N/A
Test Results: Pass

Measurement Data

Test channel	20dB bandwidth (MHz)	Results
Lowest	1.872	Pass
Middle	1.890	Pass
Highest	2.088	Pass

Test plot as follows:

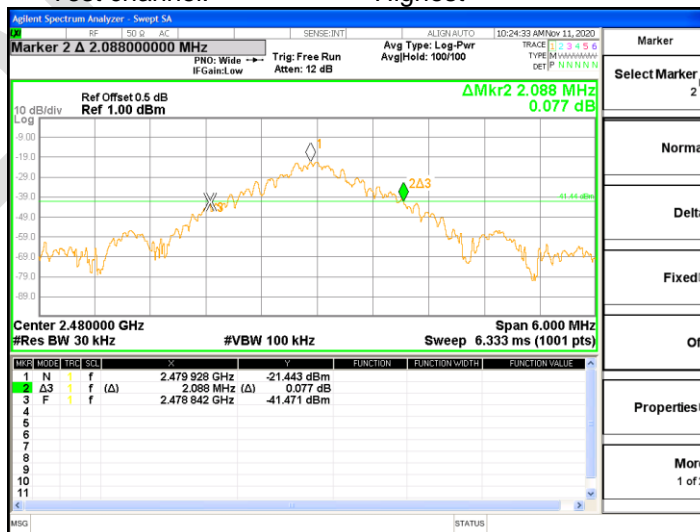
Test channel: Lowest



Test channel: Middle

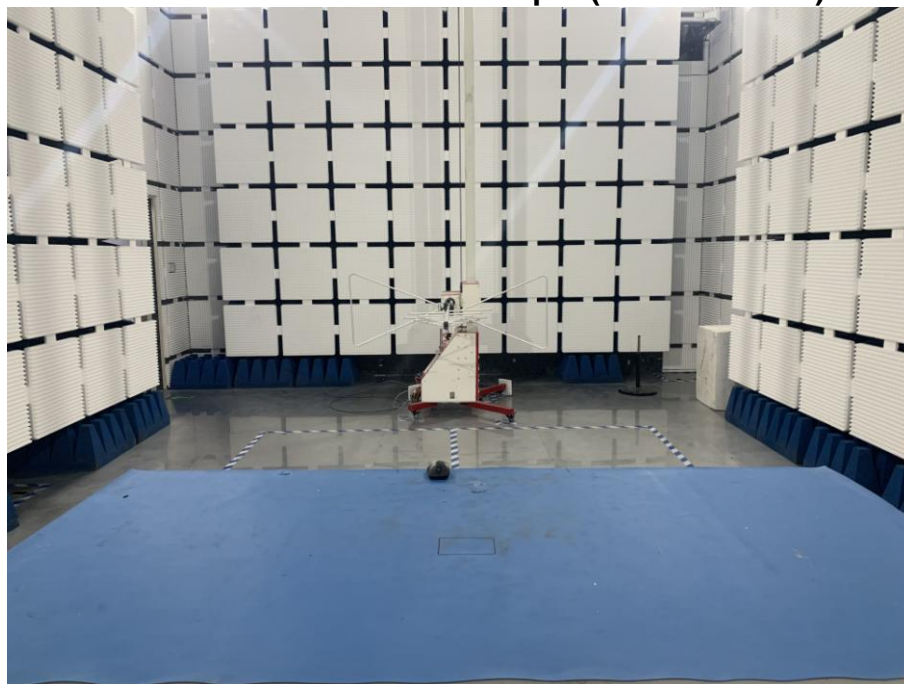


Test channel: Highest



APPENDIX 1 PHOTOGRAPHS OF TEST SETUP

Radiated emission Test Setup-2 (30MHz~1GHz)



Radiated spurious emission Test Setup-3(Above 1GHz)



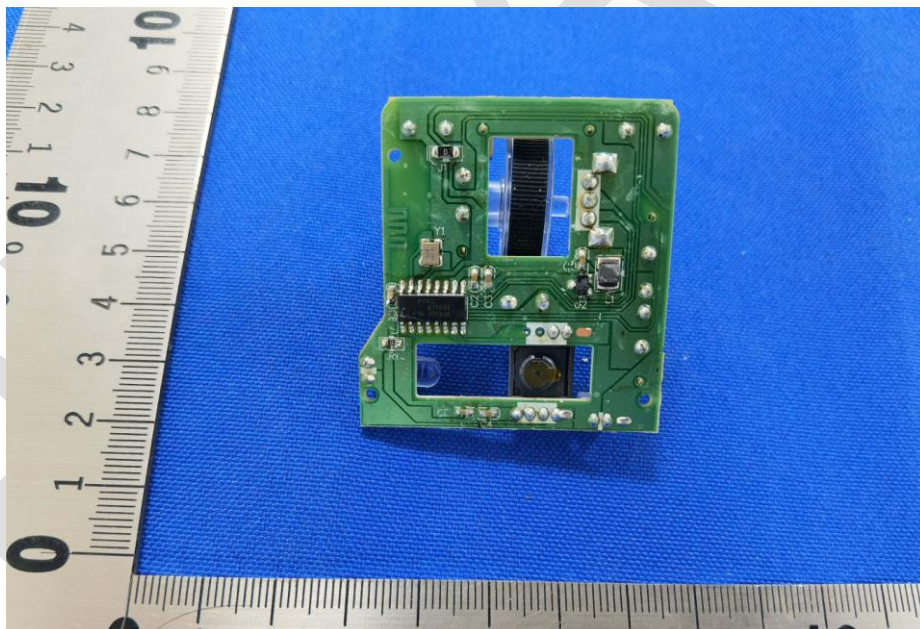
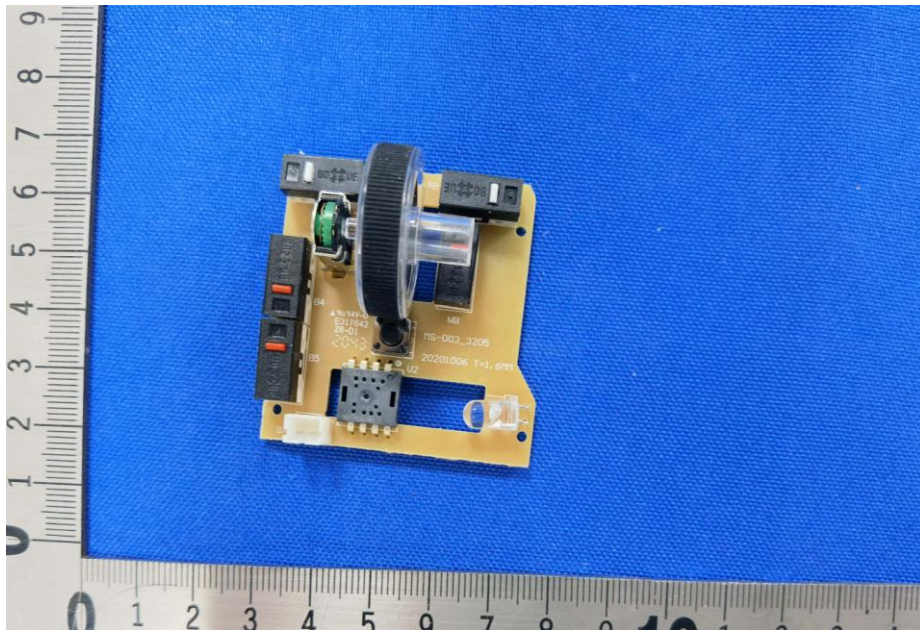
APPENDIX 2 PHOTOGRAPHS OF EUT











*** End of Report ***

The test report is effective only with both signature and specialized stamp, The result(s) shown in this report refer only to the sample(s) tested. Without written approval of BlueAsia, this report can't be reproduced except in full.

BlueAsia