

A

B

C

D

E

F

G

A

B

C

D

E

F

G

### Heiman CARBON MONOXIDE ALARM

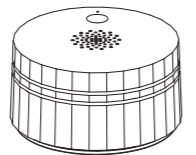

M417-32EVer1.3  
C1-S Carbon Monoxide alarm, no RF function  
C1-M Carbon Monoxide alarm with wireless communication function  
C1-W Carbon Monoxide alarm with WiFi communication function  
C1-F Carbon Monoxide alarm with wireless interconnection function  
CONFORMS TO UL STD 2034 AND CSA 6.19-17

**IMPORTANT! PLEASE READ CAREFULLY AND SAVE.**  
This user's manual contains important information about your CO Alarm's operation. If you are installing this CO Alarm for use by others, you must leave this manual—or a copy of it—with the end user.  
Shenzhen Heiman Technology Co., Ltd.  
101, No.4 Dafu Industrial Park, Kukeng Community, Guanlan Street, Longhua District, Shenzhen, China

**SAFETY INFORMATION**  
**▲WARNING!**  
• This product is intended for use in ordinary indoor locations of family living units. It is not designed to measure compliance with Occupational Safety and Health Administration (OSHA) commercial or industrial standards.  
• This carbon monoxide alarm is designed to detect carbon monoxide gas from ANY source of combustion. It is NOT designed to detect smoke, fire or any other gas.  
**▲CAUTION!**  
• This alarm will only indicate the presence of carbon monoxide gas at the sensor. Carbon monoxide gas may be present in other areas, individuals with medical problems may consider using warning devices which provide audible and visual signals for carbon monoxide concentrations under 30 ppm.  
• Do not stand too close to the unit when the alarm is sounding. It is loud to wake you in an emergency. Exposure to the horn at close range may harm your hearing.

**PACKING LIST**

| Part Name        | Quantity |
|------------------|----------|
| CO alarm         | 1 Piece  |
| Mounting bracket | 1 Piece  |
| Battery          | 1 Piece  |
| Screw            | 2 Pieces |
| Anchor plug      | 2 Pieces |
| Manual           | 1 Piece  |
| Safety sticker   | 2 Pieces |
| Disassembly pin  | 1 Piece  |

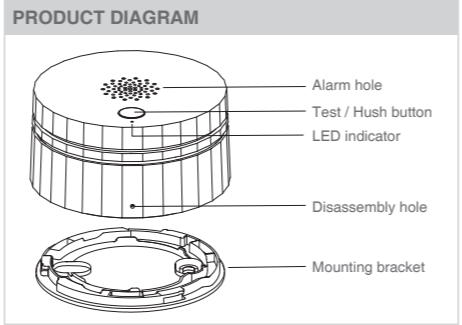

**TECHNICAL SPECIFICATIONS**

|                   |                                   |
|-------------------|-----------------------------------|
| Working Voltage   | DC3V (EVE CR123A)                 |
| Battery Life      | 3 years                           |
| Alarm Output      | Visual and audible indication     |
| Alarm Sound Level | ≥ 85dB at 10ft                    |
| Temperature Range | 40°F (4.4°C) to 100°F (37.8°C)    |
| Humidity Range    | 5%-95% relative humidity          |
| Mounting Method   | Wall mounting or ceiling mounting |
| Dimensions        | Φ70 x H37mm                       |

335mm

134mm

### RECOMMENDED INSTALLATION LOCATIONS

The National Fire Protection Association (NFPA) recommends installing a CO alarm in or near bedrooms and living areas. For added protection, install additional CO Alarms in each separate bedroom, and on every level of your home.  
• On every floor level, including finished attics and basements.  
• In every sleeping area and in every bedroom.  
• If your bedroom, hallway or large room is more than 40 feet (12m) long, install a CO alarm at each end.  
• At the top of the first-to-second floor stairway and on the basement ceiling near the entry of the stairs.  
• Installing on the ceiling is recommended, but you should locate it at a minimum of 4 inches (10cm) away from the side wall. (See Figure 1)  
• When installing the CO alarm on the wall, a distance of 4-12 inches (10-30cm) should be kept below the ceiling. (See Figure 1)  
• If you have a sloped, peaked or cathedral ceiling, the CO alarm should be installed within 3feet (90cm) of the peak of the ceiling measured horizontally. (See Figure 2)

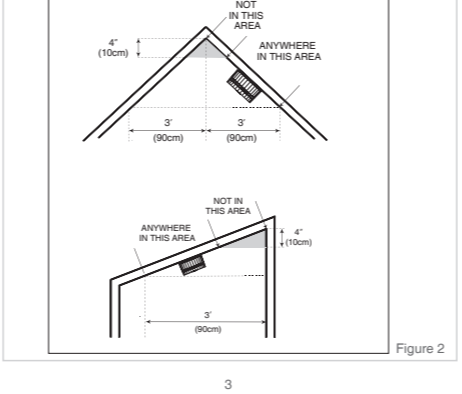
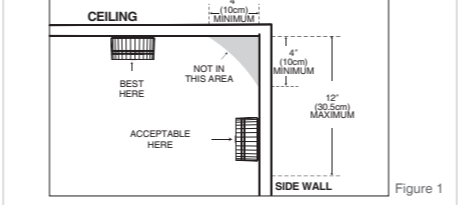

### LOCATIONS TO AVOID

For best performance, please avoid installing a CO alarm in these areas:  
• In dusty or dirty areas. Dirt and dust can build up and impair performance.  
• In areas where the normal ambient temperature is below 40°F (4.4°C) or exceeds 100°F (37.8°C), such as garages and unfinished attics.  
• Near fresh air vents, ceiling fans, or in very drafty areas. Drafts can blow CO away from the unit, preventing it from reaching the sensors.  
• Do not install in garages, furnace rooms or bathrooms. Do not locate the alarm within 5 feet (1.5 m) of any cooking appliance.  
• Less than 4 inches (10cm) from the peak of an "A" frame type ceiling. The "dead air" space may prevent CO from reaching the CO alarm.  
• Near fluorescent lights, amateur radios, or other devices that may transmit an RF signal, as electrical "noise" can interfere with the sensor.

### HOW TO INSTALL THE CO ALARM

- The CO alarm is designed to be mounted on the ceiling, or on the wall if necessary. Screw the CO alarm to the ceiling or wall using the included screws.
1. Press and insert the disassembly pin of the alarm with the disassembly pin. Remove the mounting bracket from the back of the alarm by holding the mounting bracket and twisting the alarm in the direction indicated on the alarm cover. (See Figure 3)
  2. Locate the mounting bracket in your chosen position, and mark the screw holes on the ceiling or the wall.
  3. Drill the holes at the marks with a 3/16" (5 mm) drill bit. Insert the anchor plugs and screw the mounting bracket to the ceiling or wall using the screws provided. (See Figure 4)
  4. Attach the smoke alarm to the mounting bracket and turn clockwise to lock the alarm. (See Figure 5)
  5. Test the smoke alarm. See "WEEKLY TESTING".

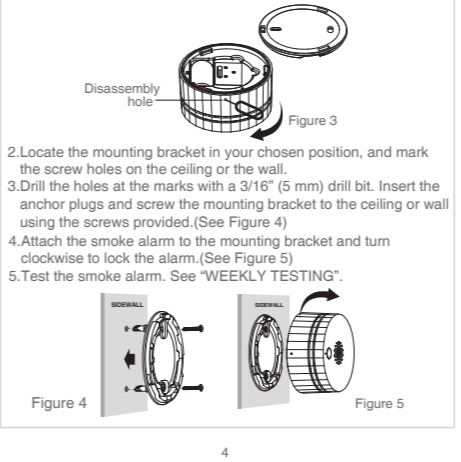

### FCC Statement

This device complies with Part 15 of the FCC Rules. Operation is subject to the following two conditions:  
(1) This device may not cause harmful interference.  
(2) This device must accept any interference received, including interference that may cause undesired operation.  
Changes or modifications not expressly approved by the party responsible for compliance could void the user's authority to operate the equipment.  
**Note:** This equipment has been tested and found to comply with the limits for a class B digital device pursuant to Part 15 of the FCC Rules. These limits are designed to provide reasonable protection against harmful interference in a residential installation. This equipment has been tested and found to comply with the limits for a Class B digital device, pursuant to part 15 of the FCC Rules. These limits are designed to provide reasonable protection against harmful interference in a residential installation. This equipment generates, uses and can radiate radio frequency energy and, if not installed and used in accordance with the instructions, may cause harmful interference to radio communications. However, there is no guarantee that interference will not occur in a particular installation. If this equipment does cause harmful interference to radio or television reception, which can be determined by turning the equipment off and on, the user is encouraged to try to correct the interference by one or more of the following measures:  
—Reorient or relocate the receiving antenna.  
—Increase the separation between the equipment and receiver.  
—Connect the equipment into an outlet on a circuit different from that to which the receiver is connected.  
—Consult the dealer or an experienced radio/TV technician for help.  
The equipment should be installed and operated with a minimum distance of 20 cm between the radiator and your body.

### ISED Statement

This device contains licence-exempt transmitter(s)/receiver(s) that comply with Innovation, Science and Economic Development Canada's licence-exempt RSS(s). Operation is subject to the following two conditions:  
(1) This device may not cause interference.  
(2) This device must accept any interference, including interference that may cause undesired operation of the device.  
This equipment should be installed and operated with a minimum distance of 10 cm between the radiator and your body.  
Le présent appareil est conforme aux CNR d'Industrie Canada applicables aux appareils radio exempts de licence. L'exploitation est autorisée aux deux conditions suivantes:  
(1) l'appareil ne doit pas produire de brouillage, et  
(2) l'utilisateur de l'appareil doit accepter tout brouillage radioélectrique subi, même si le brouillage est susceptible d'en compromettre le fonctionnement.  
Cet équipement doit être installé et utilisé avec une distance minimale de 10 cm entre le radiateur et votre corps.

### LED INDICATOR AND AUDIBLE ALARM

| CONDITION  | LED INDICATOR  | AUDIBLE ALARM  |
|--|--|--|
| Power up and Warm-up                             | The green/red/yellow LED flashes alternately for approx. 90 seconds.   | 1 short beep   |
| Standby condition                                | The green LED flashes once every 60 seconds.   | None   |
| Test condition                                   | Green, red, yellow and green LED flashes once in turns, then it repeats again 5 seconds later.                               | 4 beeps, then it repeats 5 seconds later.  |
| Alarm condition                                  | Red LED flashes 4 times every 5 seconds, 4 minutes later, alarm pattern changes to red LED flashes 4 times every 60 seconds. | 4 beeps every 5 seconds, 4 minutes later, alarm pattern changes to 4 beeps every 60 seconds. |
| Malfunction                                      | Yellow LED flashes twice every 60 seconds.   | 2 beeps every 60 seconds   |
| Low battery                                      | Yellow LED flashes once every 60 seconds.  | 1 beep every 60 seconds  |
| End-of-life                                      | Yellow LED flashes twice every 60 seconds.   | 1 long beep and 1 short beep every 60 seconds  |
| Hush condition (Silence an unwanted alarm)       | Red LED flashes 4 times every 5 seconds, 4 minutes later, alarm pattern changes to red LED flashes 4 times every 60 seconds. | None (Hush condition duration: about 4 minutes)  |
| Hush condition (Silence the low battery warning) | Yellow LED flashes once every 60 seconds.  | None (Hush condition duration: about 12 hours)   |

### WHAT TO DO WHEN THE ALARM SOUNDS

**▲WARNING!**  
Actuation of your CO alarm indicates the presence of carbon monoxide (CO) which can KILL YOU. If alarm signal sounds:  
1. Operate reset/silence button;  
2. Call your emergency services [Telephone Number: \_\_\_\_\_] (fire department or 911);  
3. Immediately move to fresh air – outdoors or by an open door/window. Do a head count to check that all persons are accounted for. Do not reenter the premises not move away from the open door/window until the emergency services responders have arrived, the premises have been aired out, and your alarm remains in its normal condition.  
4. After following steps 1 – 3, if your alarm reactivates within a 24 hour period, repeat steps 1 – 3 and call a qualified appliance technician [Telephone Number: \_\_\_\_\_] to investigate for sources of CO from fuel burning equipment and appliances, and inspect for proper operation of this equipment. If problems are identified during this inspection have the equipment serviced immediately. Note any combustion equipment not inspected by the technician and consult the manufacturers' instructions, or contact the manufacturers directly, for more information about CO safety and this equipment. Make sure that motor vehicles are not, and have not been, operating in an attached garage or adjacent to the residence.

### USING THE SILENCE FEATURE

The Silence Feature can temporarily quiet an unwanted alarm for approximately 4 minutes. Before using the silence feature, identify the source of CO and be certain a safe condition exists. To use this feature, press the Test/Hush button on the cover.  
**▲WARNING!**  
• Never remove the batteries to quiet an unwanted alarm. Removing the batteries disables the alarm and removes your protection.  
• The silence feature is only for your convenience and will not correct a problem. Always check your home for a potential problem after any alarm. Failure to do so can result in injury or death.  
**SILENCING THE LOW BATTERY WARNING**  
This silence feature can temporarily quiet the low battery warning "chirp" for up to 12 hours. You can silence the low battery warning "chirp" by pressing the Test/Hush button on the alarm cover. **Replace the battery as soon as possible, this unit will not operate without battery power!**

### SILENCING THE END-OF-LIFE WARNING

10 years after unit is first powered, this alarm will chirp one long beep and one short beep every 60 seconds to indicate it is time to replace the alarm.  
• Test the alarm at least once a week to verify the unit's alarm and indicator are working properly.  
• Clean the alarm annually by using compressed air or a vacuum cleaner hose. Never use water, cleaners or solvents since they may damage the unit.  
• If the CO alarm cannot be cleaned to avoid unwanted alarms, replace the alarm immediately.  
• When you hear the low battery warning "chirp" approximately once every 60 seconds please replace the battery immediately to continue your protection.

### TESTING AND MAINTENANCE

**WEEKLY TESTING**  
It is important to test this unit weekly to make sure it is working properly. Using the Test/Hush button to test this CO Alarm. Press and hold the Test/Hush button on the cover of the unit until the alarm sounds (the unit may continue to alarm for a few seconds after you release the button). If it does not alarm, make sure the unit is receiving power and test it again. If it still does not alarm, replace it immediately. During testing you will hear a loud horn pattern: 4 beeps, then it repeats 5 seconds later.  
**▲WARNING!**  
• Test the CO alarm once a week to ensure proper operation. If the CO alarm ever fails to test correctly, have it replaced immediately. The CO alarm is not working properly; it cannot alert you to a problem.  
• DO NOT stand close to the CO alarm when the horn is sounding, always stand an arms-length away from the unit when testing.

### REGULAR MAINTENANCE

To keep the CO alarm working properly, follow these simple methods:  
• Test the alarm at least once a week to verify the unit's alarm and indicator are working properly.  
• Clean the alarm annually by using compressed air or a vacuum cleaner hose. Never use water, cleaners or solvents since they may damage the unit.  
• If the CO alarm cannot be cleaned to avoid unwanted alarms, replace the alarm immediately.  
• When you hear the low battery warning "chirp" approximately once every 60 seconds please replace the battery immediately to continue your protection.

### BATTERY REPLACEMENT

The CO alarm requires one 3V battery, CR123A. The battery can be purchased at your local retail stores or where you purchased this alarm.  
**▲WARNING!**  
• Use only batteries specified by this User's Manual. Use of a different battery will have a detrimental effect on CO alarm operation. Constant exposures to high or low temperatures or high humidity may reduce battery life.  
• Unit will not operate without battery power. Alarm will warn you in advance when battery is running low so that you can replace it.  
**CARBON MONOXIDE SAFETY INFORMATION**  
Carbon Monoxide (CO) is a colourless, odourless, and tasteless poison gas that can be fatal when inhaled. CO inhibits the blood's capacity to carry oxygen.

### POSSIBLE SOURCES

The following conditions can result in transient CO situations:  
1) Excessive spillage or reverse venting of fuel burning appliances caused by:  
i) Outdoor ambient conditions such as wind direction and/or velocity, including high gusts of wind, heavy air in the vent pipes (cold/humid air with extended periods between cycles).  
ii) Negative pressure differential resulting from the use of exhaust fans.  
iii) Simultaneous operation of several fuel burning appliances competing for limited internal air.  
iv) Vent pipe connection vibrating loose from clothes dryers, furnaces, or water heaters.  
v) Obstructions in or unconventional vent pipe designs which amplify the above situations.  
2) Extended operation of unvented fuel burning devices (range, oven, fireplace, etc.).  
3) Temperature inversions which can trap exhaust gasses near the ground.  
4) Car idling in an open or closed attached garage, or near a home.  
**SYMPTOMS OF CO POISONING**  
The following symptoms are related to CARBON MONOXIDE POISONING and are to be discussed with all members of the household:  
1) Mild Exposure: Slight headache, nausea, vomiting, fatigue (often described as "flu like" symptoms).  
2) Medium Exposure: Severe throbbing headache, drowsiness, confusion, fast heart rate.  
3) Extreme Exposure: Unconsciousness, convulsions, cardiorespiratory failure, death.  
4) Many cases of reported CARBON MONOXIDE POISONING indicate that while victims are aware they are not well, they become so disoriented they are unable to save themselves by either exiting the building or calling for assistance. Young children and household pets are typically the first affected.

PDF为未转曲文件，仅供查阅  
供应商做货请用AI转曲文件

尺寸: 335\*134mm, 折叠后尺寸为67\*67mm  
材质: 80g书纸  
印刷: 正反面单色印刷

更新说明: Matter communication function 改为 wireless communication function 2022-12-23  
更新说明: 增加加拿大标准AND ULC STD 6.19, 技术参数和安装环境: 温度范围增加华氏度描述 2023-04-20  
更新说明: 更新加拿大标准为CSA 6.19-17, 产品寿命终止时间 "3 years" 改为 "10 years" 2023-05-17

注: 包材需符合RoHS, REACH认证要求

**Heiman海曼** 深圳市海曼科技股份有限公司 Shenzhen Heiman Technology Co., Ltd.

|                     |  |                       |                |
|---------------------|--|-----------------------|----------------|
| 视角:                 |  | 名称: C1海曼英文说明书UL2034认证 | 日期: 2023-06-02 |
| 未注尺寸公差参照下表<br>线性公差: |  | 型号:                   | 制图: 梁世平        |
| <=2 ±0.03           |  | 物料编号: 601012439       | 审核:            |
| > 2~25 ±0.05        |  | 版本: Ver1.3            | 准核:            |
| > 25~75 ±0.08       |  | 子件料号:                 | 比例: 1: 1       |
| > 75~100 ±0.10      |  | 单位: mm                | 图幅: 1/1        |
| > 100 ±0.15         |  | 角度公差 ±0.5°            |                |