

S

T

S

L

A

B



# LTE RADIO TEST REPORT

Report No:STS1807042W12

Issued for

Shanghai Unihertz E-Commerce Co., Ltd

Room 302, No. 5, Lane 59, Shennan Rd, Minhang district,  
Shanghai, China 201108

<b>Product Name:</b>	Smart phone
<b>Brand Name:</b>	Unihertz
<b>Model Name:</b>	Atom
<b>Series Model:</b>	N/A
<b>FCC ID:</b>	2AK6CATOM
<b>Test Standard:</b>	47 CFR Part 2, 22(H), 24(E), 27



Any reproduction of this document must be done in full. No single part of this document may be reproduced without permission from STS, All Test Data Presented in this report is only applicable to presented Test sample.



TEST RESULT CERTIFICATION

Applicant's name .....: Shanghai Unihertz E-Commerce Co., Ltd
Address .....: Room 302, No. 5, Lane 59, Shennan Rd, Minhang district, Shanghai, China 201108
Manufacture's Name .....: OBLUE Communication Technology Co.,Ltd.
Address .....: Room 406, Hivac Building, No. 2 North keji Rd, North Hi-Tech Industry Park, Nanshan district, shenzhen, China 201108

Product description

Product Name.....: Smart phone
Brand Name .....: Unihertz
Model Name .....: Atom
Series Model.....: N/A

Test Standards.....: 47 CFR Part 2, 22(H), 24(E), 27

Test procedure.....: KDB 971168 D01 v03r01 , ANSI C63.26 2015

This device described above has been tested by STS and the test results show that the equipment under test (EUT) is in compliance with the FCC requirements. And it is applicable only to the tested sample identified in the report.

This report shall not be reproduced except in full, without the written approval of STS, this document only be altered or revised by STS, personal only, and shall be noted in the revision of the document.

Date of Test .....

Date of performance of tests ..... 25 July 2018~20 Aug. 2018

Date of Issue..... 20 Aug. 2018

Test Result..... Pass

Testing Engineer : [Signature]
( Chris chen )

Technical Manager : [Signature]
( Sean she )

Authorized Signatory : [Signature]
(Vita Li)





<b>TABLE OF CONTENTS</b>	<b>Page</b>
<b>1. TEST FACTORY &amp; MEASUREMENT UNCERTAINTY</b>	<b>5</b>
<b>2. GENERAL INFORMATION</b>	<b>6</b>
<b>3. CONDUCTED OUTPUT POWER</b>	<b>17</b>
<b>4. PEAK-TO-AVERAGE RATIO</b>	<b>40</b>
<b>5. RADIATED POWER AND EFFECTIVE ISOTROPIC RADIATED POWER</b>	<b>44</b>
<b>6. OCCUPIED BANDWIDTH</b>	<b>69</b>
<b>7. CONDUCTED BAND EDGE</b>	<b>74</b>
<b>8. CONDUCTED SPURIOUS EMISSION</b>	<b>76</b>
<b>9. RADIATED SPURIOUS EMISSION</b>	<b>77</b>
<b>10. FREQUENCY STABILITY</b>	<b>122</b>
<b>PHOTOS OF TEST SETUP</b>	<b>133</b>

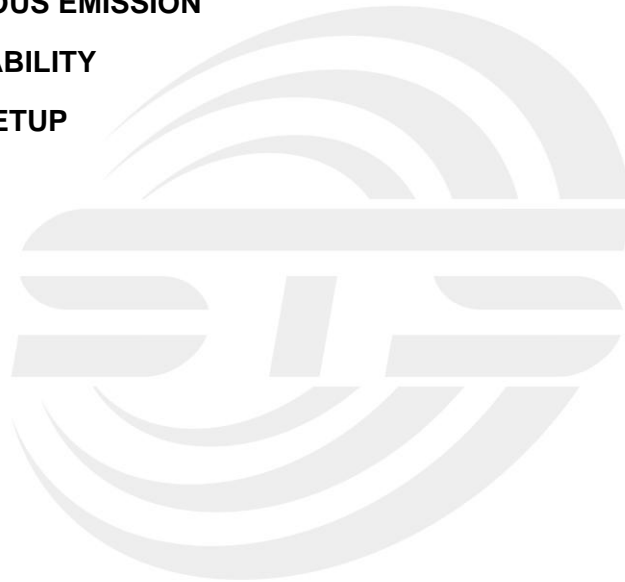



**Revision History**

Rev.	Issue Date	Report NO.	Effect Page	Contents
00	20 Aug. 2018	STS1807042W12	ALL	Initial Issue





## 1. TEST FACTORY & MEASUREMENT UNCERTAINTY

### 1.1 TEST FACTORY

Shenzhen STS Test Services Co., Ltd.

Add. : 1/F., Building B, Zhuoke Science Park, No.190, Chongqing Road, Fuyong Street, Bao'an District, Shenzhen, Guangdong, China

CNAS Registration No.: L7649; FCC Registration No.: 625569

IC Registration No.: 12108A; A2LA Certificate No.: 4338.01;

### 1.2 MEASUREMENT UNCERTAINTY

The reported uncertainty of measurement  $y \pm U$ , where expanded uncertainty  $U$  is based on a standard uncertainty multiplied by a coverage factor of  $k=2$ , providing a level of confidence of approximately **95 %**.

No.	Item	Uncertainty
3	RF power,conducted	$\pm 0.71$ dB
5	All emissions,radiated(<1G) 30MHz-200MHz	$\pm 2.83$ dB
6	All emissions,radiated(<1G) 200MHz-1000MHz	$\pm 2.94$ dB
7	All emissions,radiated(>1G)	$\pm 3.03$ dB



## 2. GENERAL INFORMATION

### 2.1 TECHNICAL SPECIFICATIONS AND REGULATIONS

#### 2.1.1 PRODUCT DESCRIPTION

A major technical description of EUT is described as following:

Product Name:	Smart phone
Trade Name	Unihertz
Model Name	Atom
Series Model	N/A
Model Difference	N/A
Frequency Bands:	U.S. Bands: <input checked="" type="checkbox"/> LTE FDD Band 2 <input checked="" type="checkbox"/> LTE FDD Band 4 <input checked="" type="checkbox"/> LTE FDD Band 5 <input checked="" type="checkbox"/> LTE FDD Band 7 <input checked="" type="checkbox"/> LTE FDD Band 12 <input checked="" type="checkbox"/> LTE FDD Band 13 <input checked="" type="checkbox"/> LTE FDD Band 17 <input checked="" type="checkbox"/> LTE TDD Band 25 <input checked="" type="checkbox"/> LTE FDD Band 26 <input checked="" type="checkbox"/> LTE TDD Band 41
SIM CARD:	SIM 1 and SIM 2 is a chipset unit and tested as single chipset,SIM 1 is used to tested
Antenna:	PIFA Antenna
Antenna gain:	LTE Band 2: 0.45dBi      LTE Band 4: 0.45dBi LTE Band 5: -0.47dBi      LTE Band 7: 0.45dBi LTE Band 12: -1.27dBi      LTE Band 13: -1.27dBi LTE Band 17: -1.27dBi      LTE Band 25: 0.45dBi LTE Band 26: -0.47dBi      LTE Band 41: 0.45dBi
Power Supply:	DC 3.85V by battery
Battery parameter:	Capacity: 2000mAh, Rated Voltage: 3.85V
Adapter:	Input: AC100-240V, 300mA, 50/60Hz Output: DC 5V, 1500mA
Extreme Vol. Limits:	DC 3.5 V to 4.4 V (Nominal DC3.85V )
Extreme Temp. Tolerance:	-30°C to +50°C
Hardware version number:	G35_V1.2
Software version number:	alps-mp-01.mp1



2.1.2 PRODUCT SPECIFICATION SUBJECTIVE TO THIS STANDARD

Product Specification Subjective To This Standard	
<b>Tx Frequency</b>	LTE Band 2:1850~1910MHz LTE Band 4:1710~1755MHz LTE Band 5:824~849MHz LTE Band 7:2500~2570MHz LTE Band 12:699~716MHz LTE Band 13:777~787MHz LTE Band 17:704~716MHz LTE Band 25:1850~1915MHz LTE Band 26:814~849MHz LTE Band 41:2496~2690MHz
<b>Rx Frequency</b>	LTE Band 2:1930~1990MHz LTE Band 4:2110~2155MHz LTE Band 5:869~894MHz LTE Band 7:2620~2690MHz LTE Band 12:729~746MHz LTE Band 13:746~756MHz LTE Band 17:734~746MHz LTE Band 25:1930~1995MHz LTE Band 26: 859~894MHz LTE Band 41:2496~2690MHz
<b>Bandwidth</b>	LTE Band 2 : 1.4MHz / 3MHz / 5MHz / 10MHz / 15MHz / 20MHz LTE Band 4 : 1.4MHz / 3MHz / 5MHz / 10MHz / 15MHz / 20MHz LTE Band 5 : 1.4MHz / 3MHz / 5MHz / 10MHz LTE Band 7 : 5MHz / 10MHz / 15MHz / 20MHz LTE Band 12 : 1.4MHz / 3MHz / 5MHz / 10MHz LTE Band 13 : 5MHz / 10MHz LTE Band 17: 5MHz / 10MHz LTE Band 25: 1.4MHz / 3MHz / 5MHz / 10MHz / 15MHz / 20MHz LTE Band 26 : 1.4MHz / 3MHz / 5MHz / 10MHz / 15MHz LTE Band 41 : 5MHz / 10MHz / 15MHz /20MHz
<b>Maximum Output Power Limit</b>	LTE Band 2 : 21.53dBm LTE Band 4 : 21.61 dBm LTE Band 5 : 22.05 dBm LTE Band 7 : 21.19dBm LTE Band 12 : 21.96 dBm LTE Band 13 : 22.12 dBm LTE Band 17 : 22.13dBm LTE Band 25: 21.44 dBm LTE Band 26 : 21.90 dBm LTE Band 41 : 20.58 dBm
<b>Type of Modulation</b>	QPSK / 16QAM



## 2.1.3 EMISSION DESIGNATOR

LTE Band 2 BW(MHz)	Emission Designator (26dBc)QPSK	Emission Designator (26dBc)16QAM
1.4	1M30G7D	1M31W7D
3	2M88G7D	2M86W7D
5	5M22G7D	5M21W7D
10	9M92G7D	9M88W7D
15	15M2G7D	16M1W7D
20	19M8G7D	19M6W7D

LTE Band 4 BW(MHz)	Emission Designator (26dBc)QPSK	Emission Designator (26dBc)16QAM
1.4	1M31G7D	1M31W7D
3	2M86G7D	2M87W7D
5	5M20G7D	5M18W7D
10	9M89G7D	9M89W7D
15	15M1G7D	15M0W7D
20	19M8G7D	19M7W7D

LTE Band 5 BW(MHz)	Emission Designator (26dBc)QPSK	Emission Designator (26dBc)16QAM
1.4	1M31G7D	1M30W7D
3	2M87G7D	2M87W7D
5	5M20G7D	5M19W7D
10	9M91G7D	9M79W7D

LTE Band 7 BW(MHz)	Emission Designator (26dBc)QPSK	Emission Designator (26dBc)16QAM
5	5M21G7D	5M32W7D
10	9M94G7D	9M89W7D
15	15M2G7D	15M1W7D
20	19M8G7D	19M8W7D

LTE Band 12 BW(MHz)	Emission Designator (26dBc)QPSK	Emission Designator (26dBc)16QAM
1.4	1M30G7D	1M31W7D
3	2M87G7D	2M87W7D
5	5M10G7D	5M09W7D
10	9M96G7D	9M87W7D





LTE Band 13 BW(MHz)	Emission Designator (26dBc)QPSK	Emission Designator (26dBc)16QAM
5	5M20G7D	5M22W7D
10	9M93G7D	9M70W7D

LTE Band 17 BW(MHz)	Emission Designator (26dBc)QPSK	Emission Designator (26dBc)16QAM
5	5M18G7D	5M18W7D
10	9M91G7D	9M79W7D

LTE Band 25 BW(MHz)	Emission Designator (26dBc)QPSK	Emission Designator (26dBc)16QAM
1.4	1M31G7D	1M30W7D
3	2M86G7D	2M86W7D
5	5M16G7D	5M20W7D
10	9M92G7D	9M81W7D
15	15M1G7D	15M1W7D
20	19M7G7D	19M8W7D

LTE Band 26 BW(MHz)	Emission Designator (26dBc)QPSK	Emission Designator (26dBc)16QAM
1.4	1M30G7D	1M30W7D
3	2M87G7D	2M86W7D
5	5M20G7D	5M19W7D
10	9M85G7D	9M83W7D
15	15M1G7D	15M0W7D

LTE Band 41 BW(MHz)	Emission Designator (26dBc)QPSK	Emission Designator (26dBc)16QAM
5	5M43G7D	5M28W7D
10	10M1G7D	10M0W7D
15	14M6G7D	14M7W7D
20	19M3G7D	19M1W7D



2.1.4 TEST CONFIGURATION OF EQUIPMENT UNDER TEST

Antenna port conducted and radiated test items listed below are performed according to KDB 971168 D01 v03r01 and ANSI C63.26 2015 Power Meas. License Digital Systems with maximum output power. Radiated measurements are performed by rotating the EUT in three different orthogonal test planes to find the maximum emission.

Remark:

1. The mark “v “ means that this configuration is chosen for testing
2. The mark “-“ means that this bandwidth is not supported.
3. The device is investigated from 30MHz to 10 times of fundamental signal for radiated

ITEMS	Band	Bandwidth (MHz)						Modulation		RB #			Test Channel		
		1.4	3	5	10	15	20	QPSK	16QAM	1	Half	Full	L	M	H
Max. Output Power	2	v	v	v	v	v	v	v	v	v	v	v	v	v	v
	4	v	v	v	v	v	v	v	v	v	v	v	v	v	v
	5	v	v	v	v			v	v	v	v	v	v	v	v
	7			v	v	v	v	v	v	v	v	v	v	v	v
	12	v	v	v	v			v	v	v	v	v	v	v	v
	13			v	v			v	v	v	v	v		v	
	17			v	v			v	v	v	v	v	v	v	v
	25	v	v	v	v	v	v	v	v	v	v	v	v	v	v
	26	v	v	v	v	v		v	v	v	v	v	v	v	v
	41			v	v	v	v	v	v	v	v	v	v	v	v
Peak&Avera Ratio	2						v	v	v	v		v	v	v	v
	4						v	v	v	v		v	v	v	v
	5				v			v	v	v		v	v	v	v
	7						v	v	v	v		v	v	v	v
	12				v			v	v	v		v	v	v	v
	13				v			v	v	v		v		v	
	17				v			v	v	v		v	v	v	v
	25						v	v	v	v		v	v	v	v
	26					v		v	v	v		v	v	v	v
	41						v	v	v	v		v	v	v	v
26dB&99% Bandwidth	2	v	v	v	v	v	v	v	v			v	v	v	v
	4	v	v	v	v	v	v	v	v			v	v	v	v
	5	v	v	v	v			v	v			v	v	v	v
	7			v	v	v	v	v	v			v	v	v	v
	12	v	v	v	v			v	v			v	v	v	v
	13			v	v			v	v			v		v	
	17			v	v			v	v			v	v	v	v
	25	v	v	v	v	v	v	v	v			v	v	v	v
	26	v	v	v	v	v		v	v			v	v	v	v
	41			v	v	v	v	v	v			v	v	v	v



Conducted Band Edge	2	v	v	v	v	v	v	v	v	v	v	v	v	v
	4	v	v	v	v	v	v	v	v	v	v	v	v	v
	5	v	v	v	v			v	v	v		v	v	v
	7			v	v	v	v	v	v	v		v	v	v
	12	v	v	v	v			v	v	v		v	v	v
	13			v	v			v	v	v		v		v
	17			v	v			v	v	v		v	v	v
	25	v	v	v	v	v	v	v	v	v		v	v	v
	26	v	v	v	v	v		v	v	v		v	v	v
	41			v	v	v	v	v	v	v		v	v	v
Conducted Spurious Emission	2	v	v	v	v	v	v	v	v	v		v	v	v
	4	v	v	v	v	v	v	v	v	v		v	v	v
	5	v	v	v	v			v	v	v		v	v	v
	7			v	v	v	v	v	v	v		v	v	v
	12	v	v	v	v			v	v	v		v	v	v
	13			v	v			v	v	v			v	
	17			v	v			v	v	v		v	v	v
	25	v	v	v	v	v	v	v	v	v		v	v	v
	26	v	v	v	v	v		v	v	v		v	v	v
	41			v	v	v	v	v	v	v		v	v	v
Frequency Stability	2				v			v				v		v
	4				v			v				v		v
	5				v			v				v		v
	7				v			v				v		v
	12				v			v				v		v
	13				v			v				v		v
	17				v			v				v		v
	25				v			v				v		v
	26				v			v				v		v
	41				v			v				v		v
E.R.P.& E.I.R.P.	2	v	v	v	v	v	v	v	v	v		v	v	v
	4	v	v	v	v	v	v	v	v	v		v	v	v
	5	v	v	v	v			v	v	v		v	v	v
	7			v	v	v	v	v	v	v		v	v	v
	12	v	v	v	v			v	v	v		v	v	v
	13			v	v			v	v	v			v	
	17			v	v			v	v	v		v	v	v
	25	v	v	v	v	v	v	v	v	v		v	v	v
	26	v	v	v	v	v		v	v	v		v	v	v
	41			v	v	v	v	v	v	v		v	v	v



Radiated Spurious Emission	2	v	v	v	v	v	v	v		v			v	v	v
	4	v	v	v	v	v	v	v		v			v	v	v
	5	v	v	v	v			v		v			v	v	v
	7			v	v	v	v	v		v			v	v	v
	12	v	v	v	v			v		v			v	v	v
	13			v	v			v		v				v	
	17			v	v			v		v			v	v	v
	25	v	v	v	v	v	v	v		v			v	v	v
	26	v	v	v	v	v		v		v			v	v	v
	41			v	v	v	v	v		v			v	v	v





### 2.1.5 RELATED SUBMITTAL(S) / GRANT (S)

This submittal(s) (test report) is intended for filing to comply with the 47 CFR Part 2, 24(E), 27

### 2.1.6 SPECIAL ACCESSORIES

The battery and the charger, earphone supplied by the applicant were used as accessories and being tested with eut intended for fcc grant together.

### 2.1.7 EUT CONFIGURATION

The EUT configuration for testing is installed on RF field strength measurement to meet the Commission's requirement and operating in a manner which intends to maximize its emission characteristics in a continuous normal application.

### 2.1.8 EUT EXERCISE

The Transmitter was operated in the maximum output power mode through Communication Tester. The TX frequency was fixed which was for the purpose of the measurements.

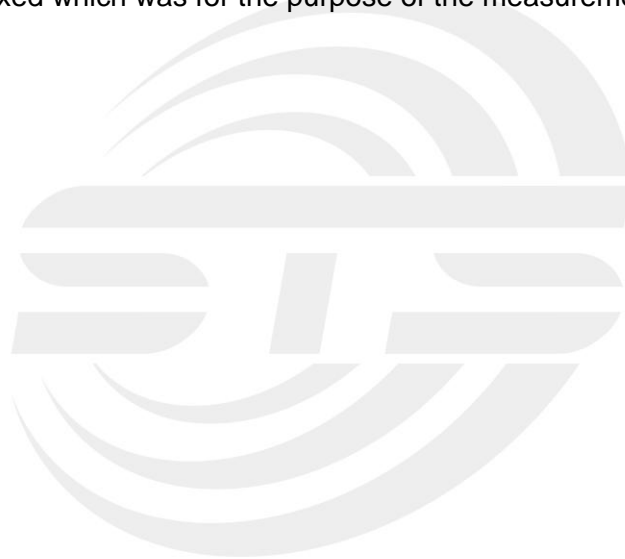



### 2.1.9 CONFIGURATION OF EUT SYSTEM

The EUT configuration for testing is installed on RF field strength measurement to meet the Commission's requirement and operating in a manner which intends to maximize its emission characteristics in a continuous normal application.

E-1  
EUT

Table 2-1 Equipment Used in EUT System

Item	Equipment	Model No.	Serial No.	Note
N/A	N/A	N/A	N/A	N/A

Note:

- (1) The support equipment was authorized by Declaration of Confirmation.
- (2) For detachable type I/O cable should be specified the length in cm in 『Length』 column.



## 2.1.10 MEASUREMENT INSTRUMENTS

The radiated emission testing was performed according to the procedures of ANSI C63.26 2015 and FCC CFR 47 rules of 2.1046, 2.1047, 2.1049, 2.1051, 2.1053, 2.1055, 2.1057.

Kind of Equipment	Manufacturer	Type No.	Serial No.	Last Calibration	Calibrated Until
Test Receiver	R&S	ESCI	101427	2017.10.15	2018.10.14
Wireless Communications Test Set	R&S	CMW 500	131428	2018.03.11	2019.03.10
Bilog Antenna	TESEQ	CBL6111D	34678	2017.11.02	2018.11.01
Horn Antenna	Schwarzbeck	BBHA 9120D (1201)	9120D-1343	2017.10.27	2018.10.26
MXA SIGNAL Analyzer	Agilent	N9020A	MY49100060	2017.10.15	2018.10.14
Low frequency cable	N/A	R01	N/A	NCR	NCR
High frequency cable	SCHWARZBECK	AK9515H	SN-96286/96287	NCR	NCR
Signal Generator	Agilent	N5182A	MY46240556	2017.10.15	2018.10.14
Pre-mpplier (0.1M-3GHz)	EM	EM330	60538	2018.03.11	2019.03.10
PreAmplifier (1G-26.5GHz)	Agilent	8449B	60538	2017.10.15	2018.10.14
Temperature & Humidity test chamber	GZGONGWEN	GDS-250	080821	2017.10.15	2018.10.14
Band Reject filter(1920-1980MHz)	COM-MW	ZBSF-1920-1980	0092	2017.10.15	2018.10.14
Band Reject filter(880-915MHz)	COM-MW	ZBSF-C897.5-35	707	2017.10.15	2018.10.14
Band Reject filter(1710-1785MHz)	COM-MW	ZBSF-C1747.5-75	708	2017.10.15	2018.10.14
Band Reject filter(1850-1910MHz)	COM-MW	ZBSF-C1880-60	709	2017.10.15	2018.10.14
Band Reject filter(2500-2570MHz)	COM-MW	ZBSF-C2535-70	710	2017.10.15	2018.10.14
Highpass Filter	WHKX7.0/18G-8SS	Wainwright	18	2017.10.15	2018.10.14



## 2. 1.11 MEASUREMENT RESULTS EXPLANATION EXAMPLE

For all conducted test items:

The offset level is set in the spectrum analyzer to compensate the RF cable loss and attenuator factor between EUT conducted output port and spectrum analyzer. With the offset compensation, the spectrum analyzer reading level is exactly the EUT RF output level.

The spectrum analyzer offset is derived from RF cable loss and attenuator factor.

*Offset = RF Cable Loss + Attenuator Factor.*





### 3. CONDUCTED OUTPUT POWER

#### 3.1 DESCRIPTION OF THE CONDUCTED OUTPUT POWER MEASUREMENT

##### 3.1.1 MEASUREMENT METHOD

A System Simulator Was Used To Establish Communication With The EUT. Its Parameters Were Set To Force The EUT Transmitting At Maximum Output Power. The Measured Power In The Radio Frequency On The Transmitter Output Terminals Shall Be Reported.  
configuration follows KDB 971168 D01 v03r01.

##### 3.1.2 TEST SETUP

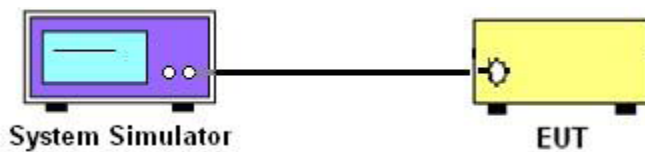

##### 3.1.3 TEST PROCEDURES

1. The Transmitter Output Port Was Connected To The System Simulator.
2. Set EUT at maximum power through the system simulator.
3. Select lowest, middle, and highest channels for each band and different modulation.
4. Measure and record the power level from the system simulator.



3.1.4 TEST RESULTS

LTE BAND 2

LTE Band 2 Maximum Average Power [dBm]						
BW [MHz]	RB Size	RB Offset	Mod	Lowest	Middle	Highest
1.4	1	0	QPSK	21.23	21.18	21.14
1.4	1	2		21.38	21.32	21.25
1.4	1	5		21.19	21.19	21.13
1.4	3	0		21.34	21.37	21.33
1.4	3	1		21.43	21.39	21.37
1.4	3	2		21.39	21.34	21.33
1.4	6	0		20.25	20.2	20.2
1.4	1	0	16-QAM	20.44	20.49	20.1
1.4	1	2		20.56	20.59	20.17
1.4	1	5		20.42	20.49	20.11
1.4	3	0		20.42	20.35	20.32
1.4	3	1		20.41	20.34	20.36
1.4	3	2		20.42	20.36	20.3
1.4	6	0		19.38	19.35	19.35
3	1	0	QPSK	21.21	21.22	21.19
3	1	7		21.35	21.3	21.31
3	1	14		21.16	21.23	21.14
3	8	0		20.24	20.18	20.19
3	8	4		20.29	20.26	20.2
3	8	7		20.23	20.13	20.15
3	15	0		20.26	20.2	20.21
3	1	0	16-QAM	20.4	20.46	20.42
3	1	7		20.56	20.59	20.58
3	1	14		20.48	20.46	20.46
3	8	0		19.49	19.44	19.39
3	8	4		19.55	19.44	19.43
3	8	7		19.51	19.4	19.33
3	15	0		19.42	19.36	19.33



LTE BAND 2

LTE Band 2 Maximum Average Power [dBm]						
BW [MHz]	RB Size	RB Offset	Mod	Lowest	Middle	Highest
5	1	0	QPSK	21.14	21.11	21.07
5	1	12		21.44	21.37	21.33
5	1	24		21.14	21.12	21.09
5	12	0		20.31	20.26	20.29
5	12	6		20.35	20.25	20.23
5	12	11		20.28	20.2	20.2
5	25	0		20.29	20.23	20.23
5	1	0	16-QAM	20.3	20.17	20.52
5	1	12		20.57	20.39	20.77
5	1	24		20.35	20.14	20.51
5	12	0		19.45	19.52	19.29
5	12	6		19.48	19.51	19.29
5	12	11		19.44	19.47	19.24
5	25	0		19.34	19.36	19.32
10	1	0	QPSK	21.16	21.17	21.16
10	1	24		21.34	21.3	21.33
10	1	49		21.16	21.18	21.16
10	25	0		20.45	20.35	20.34
10	25	12		20.43	20.28	20.3
10	25	24		20.41	20.25	20.22
10	50	0		20.45	20.28	20.27
10	1	0	16-QAM	20.4	20.42	20.42
10	1	24		20.62	20.63	20.54
10	1	49		20.41	20.44	20.39
10	25	0		19.55	19.5	19.54
10	25	12		19.53	19.38	19.51
10	25	24		19.55	19.37	19.4
10	50	0		19.48	19.33	19.34



**LTE BAND 2**

LTE Band 2 Maximum Average Power [dBm]						
BW [MHz]	RB Size	RB Offset	Mod	Lowest	Middle	Highest
15	1	0	QPSK	21.24	21.2	21.25
15	1	37		20.98	20.98	21.04
15	1	74		20.7	20.69	20.84
15	36	0		20.43	20.46	20.59
15	36	18		20.2	20.22	20.36
15	36	39		19.93	20.01	20.09
15	75	0		19.73	19.81	19.88
15	1	0		16-QAM	20.95	20.94
15	1	38	20.73		20.72	20.79
15	1	75	20.5		20.47	20.54
15	36	0	20.22		20.25	20.24
15	36	18	20		20.01	19.94
15	36	39	19.76		19.72	19.74
15	75	0	19.47		19.49	19.45
20	1	0	QPSK		21.53	21.51
20	1	49		20.97	21.01	21
20	1	99		20.72	20.77	20.77
20	50	0		20.46	20.5	20.53
20	50	24		20.16	20.26	20.24
20	50	49		19.94	19.99	19.99
20	100	0		19.69	19.76	19.73
20	1	0		16-QAM	20.99	20.98
20	1	49	20.75		20.71	20.77
20	1	99	20.54		20.49	20.57
20	50	0	20.28		20.26	20.29
20	50	24	20.04		19.99	20.04
20	50	49	19.78		19.71	19.76
20	100	0	19.53		19.43	19.53



LTE BAND 4

LTE Band 4 Maximum Average Power [dBm]						
BW [MHz]	RB Size	RB Offset	Mod	Lowest	Middle	Highest
1.4	1	0	QPSK	21.23	21.21	21.22
1.4	1	2		21.38	21.32	21.32
1.4	1	5		21.26	21.21	21.22
1.4	3	0		21.37	21.3	21.31
1.4	3	1		21.41	21.39	21.37
1.4	3	2		21.39	21.43	21.36
1.4	6	0		20.28	20.25	20.23
1.4	1	0		16-QAM	20.15	20.47
1.4	1	2	20.24		20.52	20.5
1.4	1	5	20.22		20.5	20.48
1.4	3	0	20.38		20.35	20.27
1.4	3	1	20.4		20.4	20.35
1.4	3	2	20.37		20.35	20.28
1.4	6	0	19.45		19.39	19.4
3	1	0	QPSK	21.36	21.34	21.29
3	1	7		21.48	21.51	21.46
3	1	14		21.33	21.36	21.21
3	8	0		20.39	20.33	20.33
3	8	4		20.42	20.39	20.38
3	8	7		20.34	20.35	20.31
3	15	0		20.4	20.34	20.32
3	1	0	16-QAM	20.56	20.55	20.52
3	1	7		20.68	20.71	20.6
3	1	14		20.56	20.47	20.49
3	8	0		19.66	19.58	19.47
3	8	4		19.65	19.63	19.5
3	8	7		19.61	19.54	19.43
3	15	0		19.49	19.44	19.44



LTE BAND 4

LTE Band 4 Maximum Average Power [dBm]						
BW [MHz]	RB Size	RB Offset	Mod	Lowest	Middle	Highest
5	1	0	QPSK	21.25	21.23	21.2
5	1	12		21.54	21.45	21.49
5	1	24		21.24	21.22	21.21
5	12	0		20.39	20.25	20.28
5	12	6		20.42	20.35	20.34
5	12	11		20.37	20.38	20.3
5	25	0		20.36	20.34	20.28
5	1	0		16-QAM	20.38	20.25
5	1	12	20.67		20.51	20.87
5	1	24	20.39		20.25	20.56
5	12	0	19.52		19.48	19.32
5	12	6	19.55		19.58	19.36
5	12	11	19.57		19.61	19.28
5	25	0	19.41		19.43	19.36
10	1	0	QPSK		21.32	21.32
10	1	24		21.41	21.43	21.38
10	1	49		21.27	21.27	21.24
10	25	0		20.46	20.28	20.35
10	25	12		20.44	20.36	20.31
10	25	24		20.38	20.4	20.25
10	50	0		20.44	20.36	20.32
10	1	0		16-QAM	20.48	20.53
10	1	24	20.65		20.63	20.53
10	1	49	20.56		20.5	20.48
10	25	0	19.61		19.44	19.54
10	25	12	19.58		19.49	19.5
10	25	24	19.55		19.53	19.44
10	50	0	19.5		19.42	19.36



LTE BAND 4

LTE Band 4 Maximum Average Power [dBm]						
BW [MHz]	RB Size	RB Offset	Mod	Lowest	Middle	Highest
15	1	0	QPSK	21.58	21.53	21.52
15	1	37		21.28	21.32	21.25
15	1	74		21.01	21.04	21
15	36	0		20.77	20.77	20.77
15	36	18		20.54	20.51	20.57
15	36	39		20.3	20.29	20.35
15	75	0		20.09	20.03	20.08
15	1	0		16-QAM	21.3	21.31
15	1	38	21.06		21.11	20.96
15	1	75	20.79		20.91	20.69
15	36	0	20.55		20.68	20.45
15	36	18	20.3		20.46	20.24
15	36	39	20.01		20.18	19.95
15	75	0	19.72		19.97	19.73
20	1	0	QPSK		21.61	21.56
20	1	49		21.36	21.31	21.31
20	1	99		21.13	21.02	21.05
20	50	0		20.86	20.73	20.82
20	50	24		20.58	20.46	20.57
20	50	49		20.37	20.18	20.36
20	100	0		20.1	19.96	20.14
20	1	0		16-QAM	21.35	21.3
20	1	49	21.11		21.05	20.99
20	1	99	20.9		20.77	20.7
20	50	0	20.63		20.54	20.45
20	50	24	20.34		20.29	20.2
20	50	49	20.06		20.03	19.9
20	100	0	19.84		19.75	19.67



LTE BAND 5

LTE Band 5 Maximum Average Power [dBm]						
BW [MHz]	RB Size	RB Offset	Mod	Lowest	Middle	Highest
1.4	1	0	QPSK	21.81	21.76	21.76
1.4	1	2		21.86	21.9	21.82
1.4	1	5		21.79	21.76	21.72
1.4	3	0		21.92	21.87	21.85
1.4	3	1		21.96	21.92	21.94
1.4	3	2		21.91	21.87	21.86
1.4	6	0		20.88	20.84	20.86
1.4	1	0		16-QAM	20.78	21.06
1.4	1	2	20.88		21.22	21.11
1.4	1	5	20.76		21.01	21.09
1.4	3	0	20.91		21.01	20.91
1.4	3	1	21.06		21	20.94
1.4	3	2	20.99		20.91	20.91
1.4	6	0	20		19.91	20
3	1	0	QPSK		21.9	21.9
3	1	7		21.98	22.01	22.01
3	1	14		21.83	21.85	21.9
3	8	0		20.98	20.92	20.97
3	8	4		21	20.99	20.98
3	8	7		20.97	20.92	20.9
3	15	0		20.97	20.92	20.95
3	1	0		16-QAM	21.17	21.17
3	1	7	21.28		21.3	21.31
3	1	14	21.15		21.13	21.17
3	8	0	20.15		20.1	20.05
3	8	4	20.17		20.12	20.01
3	8	7	20.15		20.06	19.95
3	15	0	20.05		19.97	19.99





**LTE BAND 5**

LTE Band 5 Maximum Average Power [dBm]						
BW [MHz]	RB Size	RB Offset	Mod	Lowest	Middle	Highest
5	1	0	QPSK	22.01	22.03	22.04
5	1	12		21.74	21.75	21.78
5	1	24		21.48	21.53	21.5
5	12	0		21.21	21.28	21.28
5	12	6		21	21	21.03
5	12	11		20.71	20.77	20.76
5	25	0		20.46	20.56	20.55
5	1	0		16-QAM	21.74	21.74
5	1	12	21.5		21.51	21.57
5	1	24	21.21		21.3	21.37
5	12	0	20.97		21.05	21.07
5	12	6	20.7		20.77	20.81
5	12	11	20.42		20.54	20.54
5	25	0	20.15		20.3	20.32
10	1	0	QPSK		22.03	22.05
10	1	24		21.78	21.83	21.8
10	1	49		21.53	21.56	21.56
10	25	0		21.25	21.28	21.28
10	25	12		21.01	20.98	21.05
10	25	24		20.75	20.76	20.83
10	50	0		20.48	20.48	20.6
10	1	0		16-QAM	21.78	21.75
10	1	24	21.5		21.5	21.48
10	1	49	21.29		21.25	21.25
10	25	0	20.99		20.99	20.99
10	25	12	20.79		20.69	20.73
10	25	24	20.5		20.41	20.48
10	50	0	20.21		20.12	20.22



LTE BAND 7

LTE Band 7 Maximum Average Power [dBm]						
BW [MHz]	RB Size	RB Offset	Mod	Lowest	Middle	Highest
5	1	0	QPSK	20.88	20.85	20.86
5	1	12		21.14	21.12	21.14
5	1	24		20.85	20.84	20.86
5	12	0		19.93	19.88	19.83
5	12	6		20	19.94	19.96
5	12	11		19.97	19.92	19.98
5	25	0		19.92	19.91	19.94
5	1	0	16-QAM	19.91	19.81	20.16
5	1	12		20.21	20.06	20.43
5	1	24		19.91	19.8	20.16
5	12	0		19.05	18.99	18.82
5	12	6		19.1	19.09	18.92
5	12	11		19.1	19.13	18.92
5	25	0		18.96	19	18.95
10	1	0	QPSK	20.96	20.88	20.95
10	1	24		21.06	20.99	21.05
10	1	49		20.91	20.89	20.95
10	25	0		19.99	19.87	19.9
10	25	12		19.97	19.93	19.94
10	25	24		19.96	20	20.01
10	50	0		19.96	19.94	19.96
10	1	0	16-QAM	20.08	20	20.05
10	1	24		20.2	20.14	20.14
10	1	49		20.04	20.05	20.04
10	25	0		19.07	18.92	19.01
10	25	12		19.05	19.01	19.08
10	25	24		19.02	19.04	19.12
10	50	0		18.98	18.95	19



LTE BAND 7

LTE Band 7 Maximum Average Power [dBm]						
BW [MHz]	RB Size	RB Offset	Mod	Lowest	Middle	Highest
15	1	0	QPSK	21.16	21.13	21.16
15	1	37		20.87	20.88	20.93
15	1	74		20.6	20.65	20.7
15	36	0		20.38	20.42	20.41
15	36	18		20.16	20.16	20.13
15	36	39		19.95	19.87	19.89
15	75	0		19.71	19.66	19.63
15	1	0		16-QAM	20.88	20.85
15	1	38	20.65		20.62	20.63
15	1	75	20.36		20.4	20.35
15	36	0	20.07		20.2	20.13
15	36	18	19.83		19.91	19.87
15	36	39	19.55		19.64	19.66
15	75	0	19.34		19.4	19.42
20	1	0	QPSK		21.18	21.15
20	1	49		20.94	20.94	20.94
20	1	99		20.68	20.71	20.69
20	50	0		20.48	20.44	20.39
20	50	24		20.2	20.19	20.12
20	50	49		19.91	19.96	19.85
20	100	0		19.67	19.66	19.57
20	1	0		16-QAM	20.91	20.88
20	1	49	20.62		20.6	20.69
20	1	99	20.33		20.32	20.41
20	50	0	20.06		20.06	20.17
20	50	24	19.77		19.84	19.96
20	50	49	19.54		19.57	19.74
20	100	0	19.29		19.32	19.48



LTE BAND 12

LTE Band 12 Maximum Average Power [dBm]						
BW [MHz]	RB Size	RB Offset	Mod	Lowest	Middle	Highest
1.4	1	0	QPSK	21.71	21.72	21.68
1.4	1	2		21.8	21.79	21.78
1.4	1	5		21.71	21.7	21.68
1.4	3	0		21.83	21.8	21.8
1.4	3	1		21.89	21.88	21.85
1.4	3	2		21.82	21.84	21.85
1.4	6	0		20.77	20.74	20.72
1.4	1	0	16-QAM	20.6	20.93	20.83
1.4	1	2		20.73	20.98	20.95
1.4	1	5		20.61	20.96	20.9
1.4	3	0		20.83	20.86	20.74
1.4	3	1		20.87	20.9	20.78
1.4	3	2		20.83	20.8	20.78
1.4	6	0		19.94	19.89	19.82
3	1	0	QPSK	21.76	21.81	21.79
3	1	7		21.9	21.91	21.92
3	1	14		21.75	21.78	21.81
3	8	0		20.76	20.76	20.8
3	8	4		20.85	20.8	20.79
3	8	7		20.83	20.74	20.75
3	15	0		20.82	20.8	20.81
3	1	0	16-QAM	20.93	21.04	20.94
3	1	7		21.07	21.17	21.06
3	1	14		20.98	20.96	20.98
3	8	0		20.01	20.02	19.89
3	8	4		20.06	20.03	19.87
3	8	7		20.05	19.96	19.86
3	15	0		19.93	19.9	19.85



LTE BAND 12

LTE Band 12 Maximum Average Power [dBm]						
BW [MHz]	RB Size	RB Offset	Mod	Lowest	Middle	Highest
5	1	0	QPSK	21.92	21.94	21.94
5	1	12		21.67	21.73	21.71
5	1	24		21.4	21.44	21.41
5	12	0		21.18	21.19	21.18
5	12	6		20.93	20.96	20.89
5	12	11		20.68	20.73	20.67
5	25	0		20.45	20.53	20.44
5	1	0	16-QAM	21.64	21.72	21.69
5	1	12		21.39	21.46	21.42
5	1	24		21.19	21.23	21.18
5	12	0		20.89	20.98	20.97
5	12	6		20.67	20.75	20.76
5	12	11		20.46	20.52	20.54
5	25	0		20.21	20.3	20.29
10	1	0	QPSK	21.93	21.95	21.96
10	1	24		21.69	21.75	21.75
10	1	49		21.46	21.49	21.51
10	25	0		21.17	21.24	21.3
10	25	12		20.96	21.01	21
10	25	24		20.73	20.81	20.71
10	50	0		20.48	20.53	20.47
10	1	0	16-QAM	21.71	21.65	21.74
10	1	24		21.45	21.39	21.5
10	1	49		21.15	21.11	21.25
10	25	0		20.89	20.84	20.98
10	25	12		20.68	20.58	20.68
10	25	24		20.42	20.34	20.47
10	50	0		20.19	20.1	20.17



LTE BAND 13

LTE Band 13 Maximum Average Power [dBm]						
BW [MHz]	RB Size	RB Offset	Mod	Lowest	Middle	Highest
5	1	0	QPSK	21.77	21.77	21.75
5	1	12		22	22	21.97
5	1	24		21.79	21.72	21.77
5	12	0		20.79	20.75	20.77
5	12	6		20.88	20.86	20.84
5	12	11		20.87	20.86	20.84
5	25	0		20.87	20.85	20.77
5	1	0	16-QAM	20.76	20.79	21.09
5	1	12		21.11	20.96	21.28
5	1	24		20.83	20.72	21.11
5	12	0		19.87	19.93	19.66
5	12	6		19.96	20	19.76
5	12	11		19.98	20.02	19.74
5	25	0		19.86	19.85	19.8
10	1	0	QPSK	/	21.8	/
10	1	24		/	22.12	/
10	1	49		/	21.81	/
10	25	0		/	20.82	/
10	25	12		/	20.89	/
10	25	24		/	20.87	/
10	50	0		/	20.85	/
10	1	0	16-QAM	/	20.94	/
10	1	24		/	21.05	/
10	1	49		/	20.93	/
10	25	0		/	19.89	/
10	25	12		/	19.96	/
10	25	24		/	19.91	/
10	50	0		/	19.84	/



LTE BAND 17

LTE Band 17 Maximum Average Power [dBm]						
BW [MHz]	RB Size	RB Offset	Mod	Lowest	Middle	Highest
5	1	0	QPSK	21.57	21.52	21.59
5	1	12		22	21.98	21.92
5	1	24		21.62	21.54	21.61
5	12	0		20.69	20.7	20.65
5	12	6		20.7	20.71	20.7
5	12	11		20.66	20.66	20.65
5	25	0		20.68	20.71	20.67
5	1	0		16-QAM	20.89	20.91
5	1	12	21.38		21.38	21.36
5	1	24	20.91		20.91	20.97
5	12	0	19.78		19.93	19.7
5	12	6	19.84		19.9	19.8
5	12	11	19.78		19.85	19.71
5	25	0	19.73		19.73	19.72
10	1	0	QPSK		21.62	21.6
10	1	24		22.13	22.05	21.98
10	1	49		21.07	21.12	21.19
10	25	0		20.85	20.89	20.93
10	25	12		20.63	20.6	20.69
10	25	24		20.33	20.32	20.39
10	50	0		20.09	20.08	20.18
10	1	0		16-QAM	21.35	21.39
10	1	24	21.09		21.15	21.2
10	1	49	20.89		20.91	20.95
10	25	0	20.65		20.67	20.67
10	25	12	20.39		20.46	20.45
10	25	24	20.09		20.26	20.19
10	50	0	19.84		19.98	19.93



LTE BAND 25

LTE Band 25 Maximum Average Power [dBm]						
BW [MHz]	RB Size	RB Offset	Mod	Lowest	Middle	Highest
1.4	1	0	QPSK	21.19	21.08	21.13
1.4	1	2		21.3	21.3	21.34
1.4	1	5		21.16	21.14	21.15
1.4	3	0		21.32	21.28	21.22
1.4	3	1		21.38	21.33	21.28
1.4	3	2		21.35	21.31	21.27
1.4	6	0		20.26	20.16	20.2
1.4	1	0		16-QAM	20.1	20.4
1.4	1	2	20.24		20.54	20.35
1.4	1	5	20.1		20.37	20.26
1.4	3	0	20.38		20.33	20.16
1.4	3	1	20.39		20.38	20.2
1.4	3	2	20.36		20.24	20.19
1.4	6	0	19.42		19.29	19.23
3	1	0	QPSK		21.16	21.13
3	1	7		21.32	21.28	21.29
3	1	14		21.12	21.07	21.17
3	8	0		20.23	20.14	20.12
3	8	4		20.21	20.14	20.12
3	8	7		20.16	20.1	20.11
3	15	0		20.2	20.13	20.12
3	1	0		16-QAM	20.35	20.42
3	1	7	20.51		20.51	20.4
3	1	14	20.36		20.34	20.15
3	8	0	19.49		19.36	19.25
3	8	4	19.46		19.35	19.24
3	8	7	19.42		19.33	19.22
3	15	0	19.34		19.26	19.21





**LTE BAND 25**

LTE Band 25 Maximum Average Power [dBm]						
BW [MHz]	RB Size	RB Offset	Mod	Lowest	Middle	Highest
5	1	0	QPSK	21.09	21.08	21.04
5	1	12		21.33	21.3	21.28
5	1	24		21.1	21.08	21.03
5	12	0		20.25	20.13	20.11
5	12	6		20.27	20.17	20.16
5	12	11		20.19	20.13	20.14
5	25	0		20.22	20.16	20.1
5	1	0		16-QAM	20.2	20.11
5	1	12	20.46		20.33	20.65
5	1	24	20.25		20.05	20.38
5	12	0	19.43		19.39	19.12
5	12	6	19.39		19.44	19.18
5	12	11	19.36		19.41	19.14
5	25	0	19.29		19.26	19.18
10	1	0	QPSK		21.18	21.13
10	1	24		21.27	21.25	21.2
10	1	49		21.17	21.1	21.17
10	25	0		20.33	20.3	20.26
10	25	12		20.3	20.26	20.21
10	25	24		20.32	20.2	20.23
10	50	0		20.32	20.25	20.26
10	1	0		16-QAM	20.37	20.39
10	1	24	20.56		20.51	20.48
10	1	49	20.41		20.39	20.18
10	25	0	19.52		19.42	19.46
10	25	12	19.47		19.4	19.42
10	25	24	19.47		19.33	19.38
10	50	0	19.43		19.37	19.36



LTE BAND 25

LTE Band 25 Maximum Average Power [dBm]						
BW [MHz]	RB Size	RB Offset	Mod	Lowest	Middle	Highest
15	1	0	QPSK	21.42	21.36	21.37
15	1	37		21.13	21.1	21.13
15	1	74		20.83	20.87	20.88
15	36	0		20.56	20.58	20.67
15	36	18		20.27	20.29	20.38
15	36	39		20.04	20.03	20.09
15	75	0		19.79	19.77	19.82
15	1	0		16-QAM	21.14	21.15
15	1	38	20.92		20.88	20.91
15	1	75	20.66		20.59	20.69
15	36	0	20.38		20.38	20.41
15	36	18	20.16		20.13	20.12
15	36	39	19.88		19.86	19.84
15	75	0	19.59		19.59	19.56
20	1	0	QPSK		21.44	21.38
20	1	49		21.24	21.15	21.11
20	1	99		20.95	20.95	20.89
20	50	0		20.74	20.7	20.69
20	50	24		20.47	20.42	20.4
20	50	49		20.24	20.16	20.16
20	100	0		20.04	19.94	19.91
20	1	0		16-QAM	21.21	21.15
20	1	49	21		20.86	20.86
20	1	99	20.73		20.63	20.65
20	50	0	20.47		20.38	20.39
20	50	24	20.18		20.12	20.11
20	50	49	19.9		19.84	19.9
20	100	0	19.61		19.6	19.61



LTE BAND 26

LTE Band 26 Maximum Average Power [dBm]						
BW [MHz]	RB Size	RB Offset	Mod	Lowest	Middle	Highest
1.4	1	0	QPSK	21.68	21.6	21.5
1.4	1	2		21.73	21.64	21.62
1.4	1	5		21.65	21.53	21.54
1.4	3	0		21.71	21.7	21.68
1.4	3	1		21.81	21.74	21.7
1.4	3	2		21.76	21.66	21.61
1.4	6	0		20.68	20.67	20.73
1.4	1	0		16-QAM	20.54	20.84
1.4	1	2	20.73		21	20.95
1.4	1	5	20.6		20.88	20.87
1.4	3	0	20.86		20.79	20.72
1.4	3	1	20.79		20.81	20.74
1.4	3	2	20.83		20.74	20.76
1.4	6	0	19.75		19.71	19.75
3	1	0	QPSK		21.71	21.67
3	1	7		21.81	21.75	21.72
3	1	14		21.65	21.6	21.6
3	8	0		20.75	20.68	20.71
3	8	4		20.78	20.71	20.7
3	8	7		20.75	20.72	20.63
3	15	0		20.74	20.73	20.66
3	1	0		16-QAM	20.95	20.93
3	1	7	21.05		21.08	21.11
3	1	14	20.97		20.91	20.93
3	8	0	19.92		19.84	19.83
3	8	4	19.98		19.88	19.76
3	8	7	19.93		19.86	19.74
3	15	0	19.8		19.75	19.72



LTE BAND 26

LTE Band 26 Maximum Average Power [dBm]						
BW [MHz]	RB Size	RB Offset	Mod	Lowest	Middle	Highest
5	1	0	QPSK	21.66	21.59	21.45
5	1	12		21.87	21.78	21.71
5	1	24		21.59	21.57	21.53
5	12	0		20.7	20.62	20.64
5	12	6		20.8	20.69	20.68
5	12	11		20.72	20.78	20.57
5	25	0		20.72	20.73	20.62
5	1	0		16-QAM	20.78	20.66
5	1	12	21.07		20.93	21.15
5	1	24	20.8		20.65	21
5	12	0	19.83		19.81	19.64
5	12	6	19.92		19.89	19.65
5	12	11	19.83		19.91	19.53
5	25	0	19.73		19.72	19.66
10	1	0	QPSK		21.67	21.62
10	1	24		21.75	21.77	21.65
10	1	49		21.62	21.59	21.59
10	25	0		20.87	20.69	20.65
10	25	12		20.83	20.77	20.66
10	25	24		20.72	20.82	20.54
10	50	0		20.78	20.72	20.58
10	1	0		16-QAM	20.93	20.9
10	1	24	21.08		21.03	20.94
10	1	49	20.89		20.92	20.89
10	25	0	19.95		19.76	19.78
10	25	12	19.9		19.84	19.85
10	25	24	19.77		19.87	19.65
10	50	0	19.77		19.71	19.57



## LTE BAND 26

LTE Band 26 Maximum Average Power [dBm]						
BW [MHz]	RB Size	RB Offset	Mod	Lowest	Middle	Highest
15	1	0	QPSK	21.9	21.81	21.77
15	1	37		21.63	21.61	21.57
15	1	74		21.36	21.4	21.33
15	36	0		21.08	21.12	21.13
15	36	18		20.84	20.9	20.85
15	36	39		20.56	20.62	20.57
15	75	0		20.3	20.33	20.31
15	1	0		16-QAM	21.61	21.59
15	1	38	21.38		21.3	21.29
15	1	75	21.11		21.04	21.08
15	36	0	20.89		20.76	20.86
15	36	18	20.61		20.47	20.59
15	36	39	20.39		20.18	20.38
15	75	0	20.14		19.9	20.14



**LTE BAND 41**

LTE Band 41 Maximum Average Power [dBm]						
BW [MHz]	RB Size	RB Offset	Mod	Lowest	Middle	Highest
5	1	0	QPSK	20.21	20.22	20.49
5	1	12		20.01	20.02	20.26
5	1	24		19.79	19.75	19.99
5	12	0		19.58	19.49	19.76
5	12	6		19.32	19.22	19.47
5	12	11		19.05	18.97	19.2
5	25	0		18.78	18.72	18.98
5	1	0		19.96	19.96	20.23
5	1	12	16-QAM	19.75	19.7	20
5	1	24		19.48	19.46	19.78
5	12	0		19.22	19.23	19.57
5	12	6		19.01	18.98	19.36
5	12	11		18.76	18.76	19.09
5	25	0		18.52	18.53	18.82
10	1	0		QPSK	19.24	19.4
10	1	24	18.94		19.17	19.21
10	1	49	18.66		18.97	19
10	25	0	18.44		18.7	18.71
10	25	12	18.23		18.47	18.42
10	25	24	17.97		18.25	18.16
10	50	0	17.73		18.01	17.92
10	1	0	16-QAM		19.03	19.16
10	1	24		18.82	18.87	18.96
10	1	49		18.56	18.58	18.67
10	25	0		18.26	18.36	18.44
10	25	12		18	18.14	18.19
10	25	24		17.79	17.9	17.98
10	50	0		17.58	17.64	17.71



LTE BAND 41

LTE Band 41 Maximum Average Power [dBm]						
BW [MHz]	RB Size	RB Offset	Mod	Lowest	Middle	Highest
15	1	0	QPSK	20.25	20.28	20.53
15	1	37		20.02	20.05	20.24
15	1	74		19.81	19.79	20.02
15	36	0		19.52	19.52	19.82
15	36	18		19.27	19.25	19.57
15	36	39		19.05	19.04	19.31
15	75	0		18.77	18.75	19.03
15	1	0	16-QAM	20	19.98	20.3
15	1	38		19.76	19.77	20.01
15	1	75		19.49	19.49	19.74
15	36	0		19.2	19.28	19.5
15	36	18		18.97	19.08	19.26
15	36	39		18.71	18.78	19
15	75	0		18.44	18.55	18.74
20	1	0	QPSK	20.31	20.34	20.58
20	1	49		20.07	20.12	20.3
20	1	99		19.85	19.91	20.04
20	50	0		19.61	19.69	19.81
20	50	24		19.4	19.44	19.52
20	50	49		19.19	19.17	19.31
20	100	0		18.97	18.9	19.1
20	1	0	16-QAM	20.1	20.13	20.34
20	1	49		19.85	19.88	20.08
20	1	99		19.58	19.66	19.84
20	50	0		19.33	19.44	19.61
20	50	24		19.04	19.21	19.35
20	50	49		18.78	18.98	19.11
20	100	0		18.53	18.72	18.91

#### 4. PEAK-TO-AVERAGE RATIO

##### 4.1 DESCRIPTION OF THE CONDUCTED OUTPUT POWER MEASUREMENT

###### 4.1.1 MEASUREMENT METHOD

Use one of the procedures presented in 4.1 to measure the total peak power and record as PPK. Use one of the applicable procedures presented 4.2 to measure the total average power and record as PAvg. Both the peak and average power levels must be expressed in the same logarithmic units (e.g., dBm). Determine the PAPR from:  
 $PAPR (dB) = PPK (dBm) - PAvg (dBm)$ .

###### 4.1.2 TEST SETUP

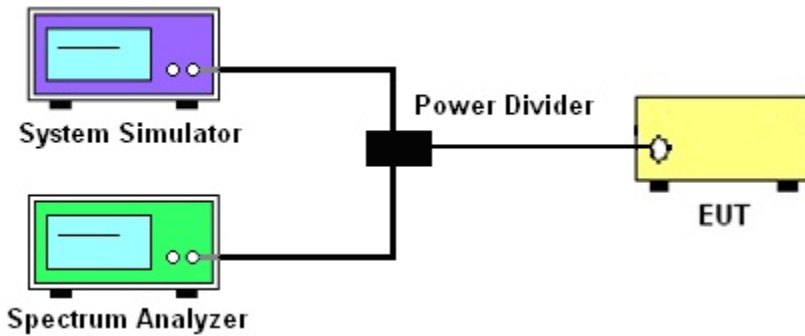

###### 4.1.3 TEST PROCEDURES

1. The testing follows FCC KDB 971168 D01 v03r01 Section 5.7.2 and ANSI C63.26 2015 Section 5.2.3.4
2. The EUT was connected to spectrum and system simulator via a power divider
3. Select lowest, middle, and highest channels for each band and different modulation.
4. Set the test probe and measure the peak and average power of the spectrum analyzer
5. Record the deviation as Peak to Average Ratio.

	LTE					
LTE BW	1.4M	3M	5M	10M	15M	20M
Span	3MHz	6MHz	10MHz	20MHz	30MHz	40MHz
RBW	30kHz	30kHz	100kHz	100kHz	300kHz	300kHz
VBW	100kHz	100kHz	300kHz	300kHz	1000kHz	1000kHz
Detector	PK/AVG	PK/AVG	PK/AVG	PK/AVG	PK/AVG	PK/AVG
Trace	Max	Max	Max	Max	Max	Max
Sweep Count	Auto	Auto	Auto	Auto	Auto	Auto





4.1.4 TEST RESULTS

**LTE BAND 2**

LTE Band 2 PAR [dBm]					
BW [MHz]	RB Size	Modulation	Lowest	Middle	Highest
			P-A	P-A	P-A
20	1	QPSK	5.28	5.5	4.9
20	100		5.76	5.8	5.54
20	1	16-QAM	6.49	6.31	5.5
20	100		6.61	6.58	6.44
Limit			≤13dBm		

**LTE BAND 4**

LTE Band 4 PAR [dBm]					
BW [MHz]	RB Size	Modulation	Lowest	Middle	Highest
			P-A	P-A	P-A
20	1	QPSK	5.38	4.31	4.8
20	100		5.77	5.43	5.24
20	1	16-QAM	5.75	5.34	5.62
20	100		6.41	6.22	5.9
Limit			≤13dBm		

**LTE BAND 5**

LTE Band 5 PAR [dBm]					
BW [MHz]	RB Size	Modulation	Lowest	Middle	Highest
			P-A	P-A	P-A
10	1	QPSK	4.39	5.38	5.15
10	50		5.61	5.52	5.81
10	1	16-QAM	5.14	6.25	5.9
10	50		6.44	6.38	6.58
Limit			≤13dBm		



**LTE BAND 7**

LTE Band 7 PAR [dBm]					
BW [MHz]	RB Size	Modulation	Lowest	Middle	Highest
			P-A	P-A	P-A
20	1	QPSK	4.55	4.78	4.16
20	100		5.37	5.47	5.4
20	1	16-QAM	5.56	5.54	4.73
20	100		6.15	6.16	6.19
Limit			≤13dBm		

**LTE BAND 12**

LTE Band 12 PAR [dBm]					
BW [MHz]	RB Size	Modulation	Lowest	Middle	Highest
			P-A	P-A	P-A
10	1	QPSK	4.89	4.4	4.21
10	50		5.6	5.58	5.52
10	1	16-QAM	5.52	5.31	4.97
10	50		6.33	6.38	6.3
Limit			≤13dBm		

**LTE BAND 13**

LTE Band 13 PAR [dBm]				
BW [MHz]	RB Size	Modulation	Middle	
			P-A	
10	1	QPSK	3.89	
10	50		4.92	
10	1	16-QAM	4.7	
10	50		5.72	
Limit				

**LTE BAND 17**

LTE Band 17 PAR [dBm]					
BW [MHz]	RB Size	Modulation	Lowest	Middle	Highest
			P-A	P-A	P-A
10	1	QPSK	4.38	4.05	4.22
10	50		5.48	5.42	5.38
10	1	16-QAM	5.57	4.79	5.25
10	50		6.34	6.27	6.23
Limit			≤13dBm		



**LTE BAND 25**

LTE Band 25 PAR [dBm]					
BW [MHz]	RB Size	Modulation	Lowest	Middle	Highest
			P-A	P-A	P-A
20	1	QPSK	4.67	5.13	4.89
20	100		5.79	5.75	5.56
20	1	16-QAM	5.27	6.16	5.47
20	100		6.48	6.57	6.31
Limit			≤13dBm		

**LTE BAND 26**

LTE Band 26 PAR [dBm]					
BW [MHz]	RB Size	Modulation	Lowest	Middle	Highest
			P-A	P-A	P-A
15	1	QPSK	5.16	5.23	5.35
15	75		6.04	5.94	5.98
15	1	16-QAM	6.43	5.79	5.98
15	75		6.6	6.55	6.61
Limit			≤13dBm		

**LTE BAND 41**

LTE Band 41 PAR [dBm]					
BW [MHz]	RB Size	Modulation	Lowest	Middle	Highest
			P-A	P-A	P-A
20	1	QPSK	4.6	4.72	3.93
20	100		6.16	5.73	4.89
20	1	16-QAM	5.11	5.54	4.71
20	100		6.32	6.22	5.74
Limit			≤13dBm		

**NOTE:**Test chart See Appendix D

## 5. RADIATED POWER AND EFFECTIVE ISOTROPIC RADIATED POWER

### 5.1 DESCRIPTION OF THE ERP/EIRP MEASUREMENT

#### 5.1.1 MEASUREMENT METHOD

Effective radiated power output measurements by substitution method according to ANSI C63.26 2015, and the spectrum analyzer configuration follows KDB 971168 D01 Power Meas. License Digital Systems. Mobile and portable (hand-held) stations operating are limited to average ERP, Equivalent isotropic radiated power output measurements by substitution method according to ANSI C63.26 2015, and the spectrum analyzer configuration follows KDB 971168 D01 Power Meas, Mobile and portable (hand-held) stations operating are limited to average EIRP.

#### 5.1.2 TEST SETUP

The procedure of radiated spurious emissions is as follows:

a) Pre-calibration With pre-calibration method, the Radiated Spurious Emissions(RSE) is calculated as,  $RSE = Rx(dBuV) + CL(dB) + SA(dB) + Gain(dBi) - 107(dBuV \text{ to } dBm)$  The SA is calibrated using following setup.

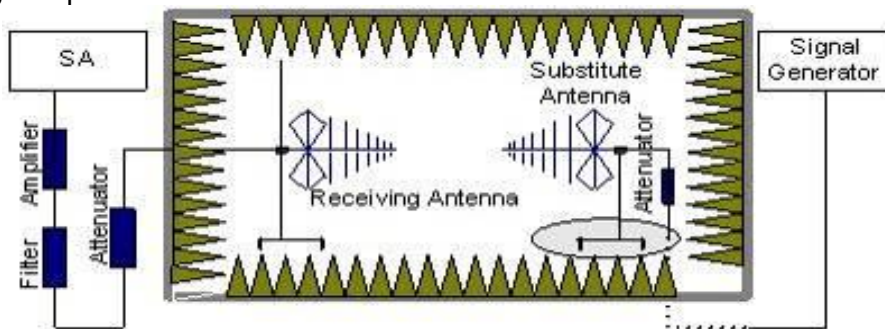

b) EUT was placed on a 1.5 meter high non-conductive stand at a 3 meter test distance from the receive antenna. A receiving antenna was placed on the antenna mast 3 meters from the test item for emission measurements. The height of receiving antenna is 0.8m. The test setup refers to figure below. Detected emissions were maximized at each frequency by rotating the test item and adjusting the receiving antenna polarization. The radiated emission measurements of all non-harmonic and harmonics of the transmit frequency through the 10th harmonic were measured with peak detector and 1MHz bandwidth.

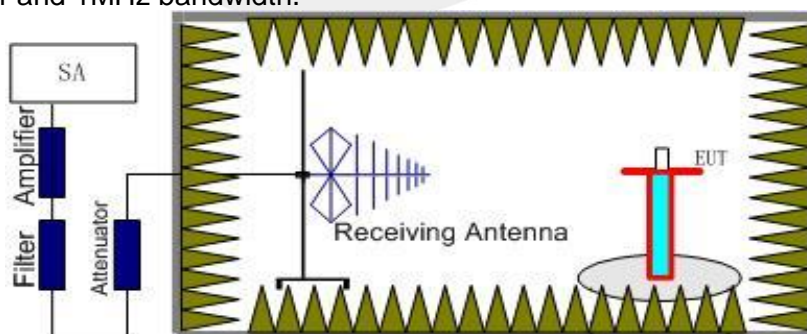

Radiated emissions measurements were made only at the upper, middle, and lower carrier frequencies It was decided that measurements at these three carrier frequencies would be sufficient to demonstrate compliance with emissions limits because it was seen that all the significant spurs occur well outside the band and no radiation was seen from a carrier in one block of any band into any of the other blocks.

The substitution method is used. Substitution values at each frequency are measured before and saved to the test software. A "reference path loss" is established and the ARpl is the attenuation of "reference path loss", and including the gain of receive antenna, the gain of the preamplifier, the cable loss and the air loss. The measurement results are obtained as described below:  $Power = P_{Mea} + AR_{pl}$



### 5.1.3 TEST PROCEDURES

1. The testing follows FCC KDB 971168 D01v03r01 Section 5.6. and ANSI C63.26 2015 Section 5.2.
2. The EUT was placed on a non-conductive rotating platform 1.5 meters high in a semi-anechoic chamber. The radiated emission at the fundamental frequency was measured at 3 m with a test antenna and a spectrum analyzer with Peak detector.
3. During the measurement, the system simulator parameters were set to force the EUT transmitting at maximum output power. The maximum emission was recorded from analyzer power level (LVL) from the 360 degrees rotation of the turntable and the test antenna raised and lowered over a range from 1 to 4 meters in both horizontally and vertically polarized orientations.
4. Effective Isotropic Radiated Power (EIRP) was measured by substitution method according to ANSI C63.26 2015. The EUT was replaced by dipole antenna (substitution antenna) at same location, and then a known power from S.G. was applied into the dipole antenna through a Tx cable, and then recorded the maximum Analyzer reading through raised and lowered the test antenna. The correction factor (in dB) = S.G. - Tx Cable loss + Substitution antenna gain - Analyzer reading. Then the EUT's EIRP was calculated with the correction factor,  $EIRP/ERP = LVL + \text{Correction factor}$
5. RB Set greater than bandwidth, Vb Set spectrum analyzer Maximum support.





5.1.4 TEST RESULTS

Note: Test is divided into three directions, X/Y/Z. X pattern for the worst.

**LTE Band 2**

Radiated Power (EIRP) for LTE Band 2 / 1.4M									
Modulation	RB		Channel	Result					Conclusion
	Size	Offset		S G.Level (dBm)	Cable loss	Gain (dBi)	PMeas E.R.P(dBm)	Polarization	
								Of Max. ERP	
QPSK	1	0	Lowest	10.52	2.37	10.40	18.55	Horizontal	Pass
	1	0	Middle	10.53	2.39	10.42	18.56	Horizontal	Pass
	1	0	Highest	10.56	2.40	10.44	18.60	Horizontal	Pass
	1	0	Lowest	11.98	2.37	10.40	20.01	Vertical	Pass
	1	0	Middle	11.86	2.39	10.42	19.89	Vertical	Pass
	1	0	Highest	11.89	2.40	10.44	19.93	Vertical	Pass
16QAM	1	0	Lowest	9.77	2.37	10.40	17.80	Horizontal	Pass
	1	0	Middle	9.92	2.39	10.42	17.95	Horizontal	Pass
	1	0	Highest	9.49	2.40	10.44	17.53	Horizontal	Pass
	1	0	Lowest	11.11	2.37	10.40	19.14	Vertical	Pass
	1	0	Middle	11.25	2.39	10.42	19.28	Vertical	Pass
	1	0	Highest	10.81	2.40	10.44	18.85	Vertical	Pass
Limit	EIRP<2W=33dBm								



Radiated Power (EIRP) for LTE Band 2 / 3M									
Modulation	RB		Channel	Result					Conclusion
	Size	Offset		S G.Level (dBm)	Cable loss	Gain (dBi)	PMeas E.R.P(dBm)	Polarization	
								Of Max. ERP	
QPSK	1	0	Lowest	10.53	2.37	10.40	18.56	Horizontal	Pass
	1	0	Middle	10.5	2.39	10.42	18.53	Horizontal	Pass
	1	0	Highest	10.45	2.40	10.44	18.49	Horizontal	Pass
	1	0	Lowest	11.96	2.37	10.40	19.99	Vertical	Pass
	1	0	Middle	11.94	2.39	10.42	19.97	Vertical	Pass
	1	0	Highest	11.87	2.40	10.44	19.91	Vertical	Pass
16QAM	1	0	Lowest	9.66	2.37	10.40	17.69	Horizontal	Pass
	1	0	Middle	9.83	2.39	10.42	17.86	Horizontal	Pass
	1	0	Highest	9.53	2.40	10.44	17.57	Horizontal	Pass
	1	0	Lowest	11.05	2.37	10.40	19.08	Vertical	Pass
	1	0	Middle	11.2	2.39	10.42	19.23	Vertical	Pass
	1	0	Highest	10.99	2.40	10.44	19.03	Vertical	Pass
Limit	EIRP<2W=33dBm								

Radiated Power (EIRP) for LTE Band 2 / 5M									
Modulation	RB		Channel	Result					Conclusion
	Size	Offset		S G.Level (dBm)	Cable loss	Gain (dBi)	PMeas E.R.P(dBm)	Polarization	
								Of Max. ERP	
QPSK	1	0	Lowest	10.5	2.37	10.40	18.53	Horizontal	Pass
	1	0	Middle	10.29	2.39	10.42	18.32	Horizontal	Pass
	1	0	Highest	10.31	2.40	10.44	18.35	Horizontal	Pass
	1	0	Lowest	11.88	2.37	10.40	19.91	Vertical	Pass
	1	0	Middle	11.69	2.39	10.42	19.72	Vertical	Pass
	1	0	Highest	11.75	2.40	10.44	19.79	Vertical	Pass
16QAM	1	0	Lowest	9.62	2.37	10.40	17.65	Horizontal	Pass
	1	0	Middle	9.35	2.39	10.42	17.38	Horizontal	Pass
	1	0	Highest	9.83	2.40	10.44	17.87	Horizontal	Pass
	1	0	Lowest	11.07	2.37	10.40	19.10	Vertical	Pass
	1	0	Middle	10.74	2.39	10.42	18.77	Vertical	Pass
	1	0	Highest	11.2	2.40	10.44	19.24	Vertical	Pass
Limit	EIRP<2W=33dBm								



Radiated Power (EIRP) for LTE Band 2 / 10M									
Modulation	RB		Channel	Result					Conclusion
	Size	Offset		S G.Level (dBm)	Cable loss	Gain (dBi)	PMeas E.R.P(dBm)	Polarization	
								Of Max. ERP	
QPSK	1	0	Lowest	10.58	2.37	10.40	18.61	Horizontal	Pass
	1	0	Middle	10.44	2.39	10.42	18.47	Horizontal	Pass
	1	0	Highest	10.37	2.40	10.44	18.41	Horizontal	Pass
	1	0	Lowest	11.91	2.37	10.40	19.94	Vertical	Pass
	1	0	Middle	11.81	2.39	10.42	19.84	Vertical	Pass
	1	0	Highest	11.77	2.40	10.44	19.81	Vertical	Pass
16QAM	1	0	Lowest	9.73	2.37	10.40	17.76	Horizontal	Pass
	1	0	Middle	9.5	2.39	10.42	17.53	Horizontal	Pass
	1	0	Highest	9.76	2.40	10.44	17.80	Horizontal	Pass
	1	0	Lowest	11.08	2.37	10.40	19.11	Vertical	Pass
	1	0	Middle	10.99	2.39	10.42	19.02	Vertical	Pass
	1	0	Highest	11.16	2.40	10.44	19.20	Vertical	Pass
Limit	EIRP<2W=33dBm								

Radiated Power (EIRP) for LTE Band 2 / 15M									
Modulation	RB		Channel	Result					Conclusion
	Size	Offset		S G.Level (dBm)	Cable loss	Gain (dBi)	PMeas E.R.P(dBm)	Polarization	
								Of Max. ERP	
QPSK	1	0	Lowest	10.44	2.37	10.40	18.47	Horizontal	Pass
	1	0	Middle	10.4	2.39	10.42	18.43	Horizontal	Pass
	1	0	Highest	10.59	2.40	10.44	18.63	Horizontal	Pass
	1	0	Lowest	11.84	2.37	10.40	19.87	Vertical	Pass
	1	0	Middle	11.89	2.39	10.42	19.92	Vertical	Pass
	1	0	Highest	11.99	2.40	10.44	20.03	Vertical	Pass
16QAM	1	0	Lowest	10.2	2.37	10.40	18.23	Horizontal	Pass
	1	0	Middle	10.16	2.39	10.42	18.19	Horizontal	Pass
	1	0	Highest	10.3	2.40	10.44	18.34	Horizontal	Pass
	1	0	Lowest	11.69	2.37	10.40	19.72	Vertical	Pass
	1	0	Middle	11.61	2.39	10.42	19.64	Vertical	Pass
	1	0	Highest	11.69	2.40	10.44	19.73	Vertical	Pass
Limit	EIRP<2W=33dBm								





Radiated Power (EIRP) for LTE Band 2 / 20M									
Modulation	RB		Channel	Result					Conclusion
	Size	Offset		S G.Level (dBm)	Cable loss	Gain (dBi)	PMeas E.R.P(dBm)	Polarization	
								Of Max. ERP	
QPSK	1	0	Lowest	10.53	2.37	10.40	18.56	Horizontal	Pass
	1	0	Middle	10.43	2.39	10.42	18.46	Horizontal	Pass
	1	0	Highest	10.6	2.40	10.44	18.64	Horizontal	Pass
	1	0	Lowest	11.95	2.37	10.40	19.98	Vertical	Pass
	1	0	Middle	11.88	2.39	10.42	19.91	Vertical	Pass
	1	0	Highest	12.03	2.40	10.44	<b>20.07</b>	Vertical	Pass
16QAM	1	0	Lowest	10.31	2.37	10.40	18.34	Horizontal	Pass
	1	0	Middle	10.29	2.39	10.42	18.32	Horizontal	Pass
	1	0	Highest	10.41	2.40	10.44	18.45	Horizontal	Pass
	1	0	Lowest	11.7	2.37	10.40	19.73	Vertical	Pass
	1	0	Middle	11.63	2.39	10.42	19.66	Vertical	Pass
	1	0	Highest	11.72	2.40	10.44	<b>19.76</b>	Vertical	Pass
Limit	EIRP<2W=33dBm								



**LTE Band 4**

Radiated Power (EIRP) for LTE Band 4 / 1.4M									
Modulation	RB		Channel	Result					Conclusion
	Size	Offset		S G.Level (dBm)	Cable loss	Gain (dBi)	PMeas E.R.P(dBm)	Polarization	
								Of Max. ERP	
QPSK	1	0	Lowest	10.77	2.35	10.13	18.55	Horizontal	Pass
	1	0	Middle	10.64	2.36	10.16	18.44	Horizontal	Pass
	1	0	Highest	10.65	2.37	10.22	18.50	Horizontal	Pass
	1	0	Lowest	12.22	2.35	10.13	20.00	Vertical	Pass
	1	0	Middle	12.03	2.36	10.16	19.83	Vertical	Pass
	1	0	Highest	12.04	2.37	10.22	19.89	Vertical	Pass
16QAM	1	0	Lowest	9.74	2.35	10.13	17.52	Horizontal	Pass
	1	0	Middle	9.91	2.36	10.16	17.71	Horizontal	Pass
	1	0	Highest	9.86	2.37	10.22	17.71	Horizontal	Pass
	1	0	Lowest	11.1	2.35	10.13	18.88	Vertical	Pass
	1	0	Middle	11.28	2.36	10.16	19.08	Vertical	Pass
	1	0	Highest	11.3	2.37	10.22	19.15	Vertical	Pass
Limit	EIRP<1W=30dBm								

Radiated Power (EIRP) for LTE Band 4 / 3M									
Modulation	RB		Channel	Result					Conclusion
	Size	Offset		S G.Level (dBm)	Cable loss	Gain (dBi)	PMeas E.R.P(dBm)	Polarization	
								Of Max. ERP	
QPSK	1	0	Lowest	10.95	2.35	10.13	18.73	Horizontal	Pass
	1	0	Middle	10.88	2.36	10.16	18.68	Horizontal	Pass
	1	0	Highest	10.85	2.37	10.22	18.70	Horizontal	Pass
	1	0	Lowest	12.29	2.35	10.13	20.07	Vertical	Pass
	1	0	Middle	12.18	2.36	10.16	19.98	Vertical	Pass
	1	0	Highest	12.22	2.37	10.22	20.07	Vertical	Pass
16QAM	1	0	Lowest	9.96	2.35	10.13	17.74	Horizontal	Pass
	1	0	Middle	10.03	2.36	10.16	17.83	Horizontal	Pass
	1	0	Highest	10.13	2.37	10.22	17.98	Horizontal	Pass
	1	0	Lowest	11.4	2.35	10.13	19.18	Vertical	Pass
	1	0	Middle	11.42	2.36	10.16	19.22	Vertical	Pass
	1	0	Highest	11.44	2.37	10.22	19.29	Vertical	Pass
Limit	EIRP<1W=30dBm								



Radiated Power (EIRP) for LTE Band 4 / 5M									
Modulation	RB		Channel	Result					Conclusion
	Size	Offset		S G.Level (dBm)	Cable loss	Gain (dBi)	PMeas E.R.P(dBm)	Polarization	
								Of Max. ERP	
QPSK	1	0	Lowest	10.72	2.35	10.13	18.50	Horizontal	Pass
	1	0	Middle	10.77	2.36	10.16	18.57	Horizontal	Pass
	1	0	Highest	10.78	2.37	10.22	18.63	Horizontal	Pass
	1	0	Lowest	12.21	2.35	10.13	19.99	Vertical	Pass
	1	0	Middle	12.18	2.36	10.16	19.98	Vertical	Pass
	1	0	Highest	12.08	2.37	10.22	19.93	Vertical	Pass
16QAM	1	0	Lowest	9.9	2.35	10.13	17.68	Horizontal	Pass
	1	0	Middle	9.86	2.36	10.16	17.66	Horizontal	Pass
	1	0	Highest	9.83	2.37	10.22	17.68	Horizontal	Pass
	1	0	Lowest	11.23	2.35	10.13	19.01	Vertical	Pass
	1	0	Middle	11.22	2.36	10.16	19.02	Vertical	Pass
	1	0	Highest	11.33	2.37	10.22	19.18	Vertical	Pass
Limit	EIRP<1W=30dBm								

Radiated Power (EIRP) for LTE Band 4 / 10M									
Modulation	RB		Channel	Result					Conclusion
	Size	Offset		S G.Level (dBm)	Cable loss	Gain (dBi)	PMeas E.R.P(dBm)	Polarization	
								Of Max. ERP	
QPSK	1	0	Lowest	10.73	2.35	10.13	18.51	Horizontal	Pass
	1	0	Middle	10.74	2.36	10.16	18.54	Horizontal	Pass
	1	0	Highest	10.79	2.37	10.22	18.64	Horizontal	Pass
	1	0	Lowest	12.19	2.35	10.13	19.97	Vertical	Pass
	1	0	Middle	12.2	2.36	10.16	20.00	Vertical	Pass
	1	0	Highest	12.1	2.37	10.22	19.95	Vertical	Pass
16QAM	1	0	Lowest	10.04	2.35	10.13	17.82	Horizontal	Pass
	1	0	Middle	10.08	2.36	10.16	17.88	Horizontal	Pass
	1	0	Highest	9.83	2.37	10.22	17.68	Horizontal	Pass
	1	0	Lowest	11.49	2.35	10.13	19.27	Vertical	Pass
	1	0	Middle	11.43	2.36	10.16	19.23	Vertical	Pass
	1	0	Highest	11.28	2.37	10.22	19.13	Vertical	Pass
Limit	EIRP<1W=30dBm								



Radiated Power (EIRP) for LTE Band 4 / 15M									
Modulation	RB		Channel	Result					Conclusion
	Size	Offset		S G.Level (dBm)	Cable loss	Gain (dBi)	PMeas E.R.P(dBm)	Polarization	
								Of Max. ERP	
QPSK	1	0	Lowest	11.01	2.35	10.13	18.79	Horizontal	Pass
	1	0	Middle	10.91	2.36	10.16	18.71	Horizontal	Pass
	1	0	Highest	10.92	2.37	10.22	18.77	Horizontal	Pass
	1	0	Lowest	12.46	2.35	10.13	20.24	Vertical	Pass
	1	0	Middle	12.39	2.36	10.16	20.19	Vertical	Pass
	1	0	Highest	12.4	2.37	10.22	20.25	Vertical	Pass
16QAM	1	0	Lowest	10.68	2.35	10.13	18.46	Horizontal	Pass
	1	0	Middle	10.78	2.36	10.16	18.58	Horizontal	Pass
	1	0	Highest	10.71	2.37	10.22	18.56	Horizontal	Pass
	1	0	Lowest	12.17	2.35	10.13	19.95	Vertical	Pass
	1	0	Middle	12.13	2.36	10.16	19.93	Vertical	Pass
	1	0	Highest	12.15	2.37	10.22	20.00	Vertical	Pass
Limit	EIRP<1W=30dBm								

Radiated Power (EIRP) for LTE Band 4 / 20M									
Modulation	RB		Channel	Result					Conclusion
	Size	Offset		S G.Level (dBm)	Cable loss	Gain (dBi)	PMeas E.R.P(dBm)	Polarization	
								Of Max. ERP	
QPSK	1	0	Lowest	11.2	2.35	10.13	18.98	Horizontal	Pass
	1	0	Middle	10.94	2.36	10.16	18.74	Horizontal	Pass
	1	0	Highest	10.98	2.37	10.22	18.83	Horizontal	Pass
	1	0	Lowest	12.6	2.35	10.13	20.38	Vertical	Pass
	1	0	Middle	12.42	2.36	10.16	20.22	Vertical	Pass
	1	0	Highest	12.39	2.37	10.22	20.24	Vertical	Pass
16QAM	1	0	Lowest	10.73	2.35	10.13	18.51	Horizontal	Pass
	1	0	Middle	10.79	2.36	10.16	18.59	Horizontal	Pass
	1	0	Highest	10.67	2.37	10.22	18.52	Horizontal	Pass
	1	0	Lowest	12.18	2.35	10.13	19.96	Vertical	Pass
	1	0	Middle	12.12	2.36	10.16	19.92	Vertical	Pass
	1	0	Highest	12.03	2.37	10.22	19.88	Vertical	Pass
Limit	EIRP<1W=30dBm								



**LTE Band 5**

Radiated Power (EIRP) for LTE Band 5 / 1.4M									
Modulation	RB		Channel	Result					Conclusion
	Size	Offset		S G.Level (dBm)	Cable loss	Gain (dBi)	PMeas E.R.P(dBm)	Polarization	
								Of Max. EIRP	
QPSK	1	0	Lowest	13.73	1.27	6.70	19.16	Horizontal	Pass
	1	0	Middle	13.76	1.28	6.70	19.18	Horizontal	Pass
	1	0	Highest	13.59	1.29	6.70	19.00	Horizontal	Pass
	1	0	Lowest	15.1	1.27	6.70	20.53	Vertical	Pass
	1	0	Middle	15.08	1.28	6.70	20.50	Vertical	Pass
	1	0	Highest	14.99	1.29	6.70	20.40	Vertical	Pass
16QAM	1	0	Lowest	12.64	1.27	6.70	18.07	Horizontal	Pass
	1	0	Middle	12.98	1.28	6.70	18.40	Horizontal	Pass
	1	0	Highest	13.01	1.29	6.70	18.42	Horizontal	Pass
	1	0	Lowest	14.12	1.27	6.70	19.55	Vertical	Pass
	1	0	Middle	14.41	1.28	6.70	19.83	Vertical	Pass
	1	0	Highest	14.44	1.29	6.70	19.85	Vertical	Pass
Limit	ERP<7W=38.45dBm								

Radiated Power (EIRP) for LTE Band 5 / 3M									
Modulation	RB		Channel	Result					Conclusion
	Size	Offset		S G.Level (dBm)	Cable loss	Gain (dBi)	PMeas E.R.P(dBm)	Polarization	
								Of Max. EIRP	
QPSK	1	0	Lowest	13.72	1.27	6.70	19.15	Horizontal	Pass
	1	0	Middle	13.86	1.28	6.70	19.28	Horizontal	Pass
	1	0	Highest	13.69	1.29	6.70	19.10	Horizontal	Pass
	1	0	Lowest	15.11	1.27	6.70	20.54	Vertical	Pass
	1	0	Middle	15.17	1.28	6.70	20.59	Vertical	Pass
	1	0	Highest	15.05	1.29	6.70	20.46	Vertical	Pass
16QAM	1	0	Lowest	13.02	1.27	6.70	18.45	Horizontal	Pass
	1	0	Middle	12.98	1.28	6.70	18.40	Horizontal	Pass
	1	0	Highest	13.17	1.29	6.70	18.58	Horizontal	Pass
	1	0	Lowest	14.41	1.27	6.70	19.84	Vertical	Pass
	1	0	Middle	14.41	1.28	6.70	19.83	Vertical	Pass
	1	0	Highest	14.54	1.29	6.70	19.95	Vertical	Pass
Limit	ERP<7W=38.45dBm								



Radiated Power (EIRP) for LTE Band 5 / 5M									
Modulation	RB		Channel	Result					Conclusion
	Size	Offset		S G.Level (dBm)	Cable loss	Gain (dBi)	PMeas E.R.P(dBm)	Polarization	
								Of Max. EIRP	
QPSK	1	0	Lowest	13.81	1.27	6.70	19.24	Horizontal	Pass
	1	0	Middle	13.87	1.28	6.70	19.29	Horizontal	Pass
	1	0	Highest	14.01	1.29	6.70	19.42	Horizontal	Pass
	1	0	Lowest	15.19	1.27	6.70	20.62	Vertical	Pass
	1	0	Middle	15.29	1.28	6.70	20.71	Vertical	Pass
	1	0	Highest	15.42	1.29	6.70	20.83	Vertical	Pass
16QAM	1	0	Lowest	13.73	1.27	6.70	19.16	Horizontal	Pass
	1	0	Middle	13.64	1.28	6.70	19.06	Horizontal	Pass
	1	0	Highest	13.77	1.29	6.70	19.18	Horizontal	Pass
	1	0	Lowest	15.07	1.27	6.70	20.50	Vertical	Pass
	1	0	Middle	15	1.28	6.70	20.42	Vertical	Pass
	1	0	Highest	15.21	1.29	6.70	20.62	Vertical	Pass
Limit	ERP<7W=38.45dBm								

Radiated Power (EIRP) for LTE Band 5 / 10M									
Modulation	RB		Channel	Result					Conclusion
	Size	Offset		S G.Level (dBm)	Cable loss	Gain (dBi)	PMeas E.R.P(dBm)	Polarization	
								Of Max. EIRP	
QPSK	1	0	Lowest	13.92	1.27	6.70	19.35	Horizontal	Pass
	1	0	Middle	13.93	1.28	6.70	19.35	Horizontal	Pass
	1	0	Highest	13.85	1.29	6.70	19.26	Horizontal	Pass
	1	0	Lowest	15.26	1.27	6.70	20.69	Vertical	Pass
	1	0	Middle	15.36	1.28	6.70	20.78	Vertical	Pass
	1	0	Highest	15.29	1.29	6.70	20.70	Vertical	Pass
16QAM	1	0	Lowest	13.67	1.27	6.70	19.10	Horizontal	Pass
	1	0	Middle	13.6	1.28	6.70	19.02	Horizontal	Pass
	1	0	Highest	13.66	1.29	6.70	19.07	Horizontal	Pass
	1	0	Lowest	15.09	1.27	6.70	20.52	Vertical	Pass
	1	0	Middle	14.97	1.28	6.70	20.39	Vertical	Pass
	1	0	Highest	15.08	1.29	6.70	20.49	Vertical	Pass
Limit	ERP<7W=38.45dBm								



LTE Band 7

Radiated Power (EIRP) for LTE Band 7 / 5M									
Modulation	RB		Channel	Result					Conclusion
	Size	Offset		S G.Level (dBm)	Cable loss	Gain (dBi)	PMeas E.I.R.P(dBm)	Polarization	
								Of Max. EIRP	
QPSK	1	0	Lowest	9.99	2.56	10.60	18.03	Horizontal	Pass
	1	0	Middle	10.18	2.67	10.65	18.16	Horizontal	Pass
	1	0	Highest	10.13	2.72	10.70	18.11	Horizontal	Pass
	1	0	Lowest	11.47	2.56	10.60	19.51	Vertical	Pass
	1	0	Middle	11.54	2.67	10.65	19.52	Vertical	Pass
	1	0	Highest	11.63	2.72	10.70	19.61	Vertical	Pass
16QAM	1	0	Lowest	9.29	2.56	10.60	17.33	Horizontal	Pass
	1	0	Middle	9.02	2.67	10.65	17.00	Horizontal	Pass
	1	0	Highest	9.46	2.72	10.70	17.44	Horizontal	Pass
	1	0	Lowest	10.67	2.56	10.60	18.71	Vertical	Pass
	1	0	Middle	10.5	2.67	10.65	18.48	Vertical	Pass
	1	0	Highest	10.91	2.72	10.70	18.89	Vertical	Pass
Limit	EIRP<2W=33dBm								

Radiated Power (EIRP) for LTE Band 7 / 10M									
Modulation	RB		Channel	Result					Conclusion
	Size	Offset		S G.Level (dBm)	Cable loss	Gain (dBi)	PMeas E.I.R.P(dBm)	Polarization	
								Of Max. EIRP	
QPSK	1	0	Lowest	10.09	2.56	10.60	18.13	Horizontal	Pass
	1	0	Middle	10.17	2.67	10.65	18.15	Horizontal	Pass
	1	0	Highest	10.39	2.72	10.70	18.37	Horizontal	Pass
	1	0	Lowest	11.57	2.56	10.60	19.61	Vertical	Pass
	1	0	Middle	11.63	2.67	10.65	19.61	Vertical	Pass
	1	0	Highest	11.73	2.72	10.70	19.71	Vertical	Pass
16QAM	1	0	Lowest	9.27	2.56	10.60	17.31	Horizontal	Pass
	1	0	Middle	9.27	2.67	10.65	17.25	Horizontal	Pass
	1	0	Highest	9.49	2.72	10.70	17.47	Horizontal	Pass
	1	0	Lowest	10.73	2.56	10.60	18.77	Vertical	Pass
	1	0	Middle	10.63	2.67	10.65	18.61	Vertical	Pass
	1	0	Highest	10.83	2.72	10.70	18.81	Vertical	Pass
Limit	EIRP<2W=33dBm								



Radiated Power (EIRP) for LTE Band 7 / 15M									
Modulation	RB		Channel	Result					Conclusion
	Size	Offset		S G.Level (dBm)	Cable loss	Gain (dBi)	PMeas E.I.R.P(dBm)	Polarization	
								Of Max. EIRP	
QPSK	1	0	Lowest	10.44	2.56	10.60	18.48	Horizontal	Pass
	1	0	Middle	10.32	2.67	10.65	18.30	Horizontal	Pass
	1	0	Highest	10.46	2.72	10.70	18.44	Horizontal	Pass
	1	0	Lowest	11.87	2.56	10.60	19.91	Vertical	Pass
	1	0	Middle	11.79	2.67	10.65	19.77	Vertical	Pass
	1	0	Highest	11.94	2.72	10.70	19.92	Vertical	Pass
16QAM	1	0	Lowest	10.14	2.56	10.60	18.18	Horizontal	Pass
	1	0	Middle	10.15	2.67	10.65	18.13	Horizontal	Pass
	1	0	Highest	10.14	2.72	10.70	18.12	Horizontal	Pass
	1	0	Lowest	11.45	2.56	10.60	19.49	Vertical	Pass
	1	0	Middle	11.54	2.67	10.65	19.52	Vertical	Pass
	1	0	Highest	11.64	2.72	10.70	19.62	Vertical	Pass
Limit	EIRP<2W=33dBm								

Radiated Power (EIRP) for LTE Band 7 / 20M									
Modulation	RB		Channel	Result					Conclusion
	Size	Offset		S G.Level (dBm)	Cable loss	Gain (dBi)	PMeas E.I.R.P(dBm)	Polarization	
								Of Max. EIRP	
QPSK	1	0	Lowest	10.31	2.56	10.60	18.35	Horizontal	Pass
	1	0	Middle	10.47	2.67	10.65	18.45	Horizontal	Pass
	1	0	Highest	10.42	2.72	10.70	18.40	Horizontal	Pass
	1	0	Lowest	11.8	2.56	10.60	19.84	Vertical	Pass
	1	0	Middle	11.84	2.67	10.65	19.82	Vertical	Pass
	1	0	Highest	11.82	2.72	10.70	19.80	Vertical	Pass
16QAM	1	0	Lowest	10.1	2.56	10.60	18.14	Horizontal	Pass
	1	0	Middle	10.32	2.67	10.65	18.30	Horizontal	Pass
	1	0	Highest	10.31	2.72	10.70	18.29	Horizontal	Pass
	1	0	Lowest	11.52	2.56	10.60	19.56	Vertical	Pass
	1	0	Middle	11.62	2.67	10.65	19.60	Vertical	Pass
	1	0	Highest	11.71	2.72	10.70	19.69	Vertical	Pass
Limit	EIRP<2W=33dBm								





**LTE Band 12**

Radiated Power (EIRP) for LTE Band 12 / 1.4M									
Modulation	RB		Channel	Result					Conclusion
	Size	Offset		S G.Level (dBm)	Cable loss	Gain (dBi)	PMeas E.R.P(dBm)	Polarization	
								Of Max. ERP	
QPSK	1	0	Lowest	13.77	1.21	6.40	18.96	Horizontal	Pass
	1	0	Middle	13.86	1.22	6.40	19.04	Horizontal	Pass
	1	0	Highest	13.82	1.23	6.40	18.99	Horizontal	Pass
	1	0	Lowest	15.15	1.21	6.40	20.34	Vertical	Pass
	1	0	Middle	15.2	1.22	6.40	20.38	Vertical	Pass
	1	0	Highest	15.17	1.23	6.40	20.34	Vertical	Pass
16QAM	1	0	Lowest	12.68	1.21	6.40	17.87	Horizontal	Pass
	1	0	Middle	12.91	1.22	6.40	18.09	Horizontal	Pass
	1	0	Highest	13.09	1.23	6.40	18.26	Horizontal	Pass
	1	0	Lowest	14.11	1.21	6.40	19.30	Vertical	Pass
	1	0	Middle	14.4	1.22	6.40	19.58	Vertical	Pass
	1	0	Highest	14.42	1.23	6.40	19.59	Vertical	Pass
Limit	EIRP<2W=33dBm								

Radiated Power (EIRP) for LTE Band 12 / 3M									
Modulation	RB		Channel	Result					Conclusion
	Size	Offset		S G.Level (dBm)	Cable loss	Gain (dBi)	PMeas E.R.P(dBm)	Polarization	
								Of Max. ERP	
QPSK	1	0	Lowest	13.9	1.21	6.40	19.09	Horizontal	Pass
	1	0	Middle	13.92	1.22	6.40	19.10	Horizontal	Pass
	1	0	Highest	13.95	1.23	6.40	19.12	Horizontal	Pass
	1	0	Lowest	15.31	1.21	6.40	20.50	Vertical	Pass
	1	0	Middle	15.32	1.22	6.40	20.50	Vertical	Pass
	1	0	Highest	15.37	1.23	6.40	20.54	Vertical	Pass
16QAM	1	0	Lowest	13.1	1.21	6.40	18.29	Horizontal	Pass
	1	0	Middle	13.29	1.22	6.40	18.47	Horizontal	Pass
	1	0	Highest	12.96	1.23	6.40	18.13	Horizontal	Pass
	1	0	Lowest	14.53	1.21	6.40	19.72	Vertical	Pass
	1	0	Middle	14.64	1.22	6.40	19.82	Vertical	Pass
	1	0	Highest	14.38	1.23	6.40	19.55	Vertical	Pass
Limit	EIRP<2W=33dBm								



Radiated Power (EIRP) for LTE Band 12 / 5M									
Modulation	RB		Channel	Result					Conclusion
	Size	Offset		S G.Level (dBm)	Cable loss	Gain (dBi)	PMeas E.R.P(dBm)	Polarization	
								Of Max. ERP	
QPSK	1	0	Lowest	14.05	1.21	6.40	19.24	Horizontal	Pass
	1	0	Middle	14.09	1.22	6.40	19.27	Horizontal	Pass
	1	0	Highest	13.95	1.23	6.40	19.12	Horizontal	Pass
	1	0	Lowest	15.47	1.21	6.40	20.66	Vertical	Pass
	1	0	Middle	15.51	1.22	6.40	20.69	Vertical	Pass
	1	0	Highest	15.42	1.23	6.40	20.59	Vertical	Pass
16QAM	1	0	Lowest	13.84	1.21	6.40	19.03	Horizontal	Pass
	1	0	Middle	13.9	1.22	6.40	19.08	Horizontal	Pass
	1	0	Highest	13.76	1.23	6.40	18.93	Horizontal	Pass
	1	0	Lowest	15.2	1.21	6.40	20.39	Vertical	Pass
	1	0	Middle	15.3	1.22	6.40	20.48	Vertical	Pass
	1	0	Highest	15.22	1.23	6.40	20.39	Vertical	Pass
Limit	ERP<3W=34.77dBm								

Radiated Power (EIRP) for LTE Band 12 / 10M									
Modulation	RB		Channel	Result					Conclusion
	Size	Offset		S G.Level (dBm)	Cable loss	Gain (dBi)	PMeas E.R.P(dBm)	Polarization	
								Of Max. ERP	
QPSK	1	0	Lowest	14.01	1.21	6.40	19.20	Horizontal	Pass
	1	0	Middle	14.21	1.22	6.40	19.39	Horizontal	Pass
	1	0	Highest	14.02	1.23	6.40	19.19	Horizontal	Pass
	1	0	Lowest	15.47	1.21	6.40	20.66	Vertical	Pass
	1	0	Middle	15.51	1.22	6.40	20.69	Vertical	Pass
	1	0	Highest	15.51	1.23	6.40	20.68	Vertical	Pass
16QAM	1	0	Lowest	13.92	1.21	6.40	19.11	Horizontal	Pass
	1	0	Middle	13.94	1.22	6.40	19.12	Horizontal	Pass
	1	0	Highest	13.93	1.23	6.40	19.10	Horizontal	Pass
	1	0	Lowest	15.28	1.21	6.40	20.47	Vertical	Pass
	1	0	Middle	15.26	1.22	6.40	20.44	Vertical	Pass
	1	0	Highest	15.33	1.23	6.40	20.50	Vertical	Pass
Limit	ERP<3W=34.77dBm								



**LTE Band 13**

Radiated Power (EIRP) for LTE Band 13 / 5M									
Modulation	RB		Channel	Result					Conclusion
	Size	Offset		S G.Level (dBm)	Cable loss	Gain (dBi)	PMeas E.R.P(dBm)	Polarization	
								Of Max. ERP	
QPSK	1	0	Lowest	13.94	1.21	6.40	19.13	Horizontal	Pass
	1	0	Middle	15.87	1.22	6.40	21.05	Horizontal	Pass
	1	0	Highest	14.05	1.23	6.40	19.22	Horizontal	Pass
	1	0	Lowest	15.94	1.21	6.40	21.13	Vertical	Pass
	1	0	Middle	14.3	1.22	6.40	19.48	Vertical	Pass
	1	0	Highest	16.04	1.23	6.40	21.21	Vertical	Pass
16QAM	1	0	Lowest	14	1.21	6.40	19.19	Horizontal	Pass
	1	0	Middle	15.82	1.22	6.40	21.00	Horizontal	Pass
	1	0	Highest	13.99	1.23	6.40	19.16	Horizontal	Pass
	1	0	Lowest	15.67	1.21	6.40	20.86	Vertical	Pass
	1	0	Middle	14.1	1.22	6.40	19.28	Vertical	Pass
	1	0	Highest	15.9	1.23	6.40	21.07	Vertical	Pass
Limit	ERP<3W=34.77dBm								

Radiated Power (EIRP) for LTE Band 13 / 10M									
Modulation	RB		Channel	Result					Conclusion
	Size	Offset		S G.Level (dBm)	Cable loss	Gain (dBi)	PMeas E.R.P(dBm)	Polarization	
								Of Max. ERP	
QPSK	1	0	Middle	16.05	1.22	6.40	21.23	Horizontal	Pass
	1	0	Middle	14.18	1.22	6.40	19.36	Vertical	Pass
16QAM	1	0	Middle	15.8	1.22	6.40	20.98	Horizontal	Pass
	1	0	Middle	13.82	1.22	6.40	19.00	Vertical	Pass
Limit	ERP<3W=34.77dBm								



**LTE Band 17**

Radiated Power (EIRP) for LTE Band 17 / 5M									
Modulation	RB		Channel	Result					Conclusion
	Size	Offset		S G.Level (dBm)	Cable loss	Gain (dBi)	PMeas E.R.P(dBm)	Polarization	
								Of Max. ERP	
QPSK	1	0	Lowest	10.9	2.56	10.60	18.94	Horizontal	Pass
	1	0	Middle	10.83	2.67	10.65	18.81	Horizontal	Pass
	1	0	Highest	10.91	2.72	10.70	18.89	Horizontal	Pass
	1	0	Lowest	12.22	2.56	10.60	20.26	Vertical	Pass
	1	0	Middle	12.23	2.67	10.65	20.21	Vertical	Pass
	1	0	Highest	12.35	2.72	10.70	20.33	Vertical	Pass
16QAM	1	0	Lowest	10.31	2.56	10.60	18.35	Horizontal	Pass
	1	0	Middle	10.14	2.67	10.65	18.12	Horizontal	Pass
	1	0	Highest	10.37	2.72	10.70	18.35	Horizontal	Pass
	1	0	Lowest	11.61	2.56	10.60	19.65	Vertical	Pass
	1	0	Middle	11.63	2.67	10.65	19.61	Vertical	Pass
	1	0	Highest	11.67	2.72	10.70	19.65	Vertical	Pass
Limit	EIRP<2W=33dBm								

Radiated Power (EIRP) for LTE Band 17 / 10M									
Modulation	RB		Channel	Result					Conclusion
	Size	Offset		S G.Level (dBm)	Cable loss	Gain (dBi)	PMeas E.R.P(dBm)	Polarization	
								Of Max. ERP	
QPSK	1	0	Lowest	10.98	2.56	10.60	19.02	Horizontal	Pass
	1	0	Middle	11.01	2.67	10.65	18.99	Horizontal	Pass
	1	0	Highest	11.07	2.72	10.70	19.05	Horizontal	Pass
	1	0	Lowest	12.28	2.56	10.60	20.32	Vertical	Pass
	1	0	Middle	12.41	2.67	10.65	20.39	Vertical	Pass
	1	0	Highest	12.42	2.72	10.70	20.40	Vertical	Pass
16QAM	1	0	Lowest	10.6	2.56	10.60	18.64	Horizontal	Pass
	1	0	Middle	10.57	2.67	10.65	18.55	Horizontal	Pass
	1	0	Highest	10.85	2.72	10.70	18.83	Horizontal	Pass
	1	0	Lowest	12.01	2.56	10.60	20.05	Vertical	Pass
	1	0	Middle	12.04	2.67	10.65	20.02	Vertical	Pass
	1	0	Highest	12.17	2.72	10.70	20.15	Vertical	Pass
Limit	EIRP<2W=33dBm								



LTE Band 25

Radiated Power (EIRP) for LTE Band 25 / 1.4M									
Modulation	RB		Channel	Result					Conclusion
	Size	Offset		S G.Level (dBm)	Cable loss	Gain (dBi)	PMeas E.R.P(dBm)	Polarization	
								Of Max. ERP	
QPSK	1	0	Lowest	10.61	2.37	10.40	18.64	Horizontal	Pass
	1	0	Middle	10.37	2.39	10.42	18.40	Horizontal	Pass
	1	0	Highest	10.29	2.40	10.44	18.33	Horizontal	Pass
	1	0	Lowest	11.94	2.37	10.40	19.97	Vertical	Pass
	1	0	Middle	11.76	2.39	10.42	19.79	Vertical	Pass
	1	0	Highest	11.74	2.40	10.44	19.78	Vertical	Pass
16QAM	1	0	Lowest	9.32	2.37	10.40	17.35	Horizontal	Pass
	1	0	Middle	9.66	2.39	10.42	17.69	Horizontal	Pass
	1	0	Highest	9.59	2.40	10.44	17.63	Horizontal	Pass
	1	0	Lowest	10.73	2.37	10.40	18.76	Vertical	Pass
	1	0	Middle	11.16	2.39	10.42	19.19	Vertical	Pass
	1	0	Highest	10.99	2.40	10.44	19.03	Vertical	Pass
Limit	EIRP<2W=33dBm								

Radiated Power (EIRP) for LTE Band 25 / 3M									
Modulation	RB		Channel	Result					Conclusion
	Size	Offset		S G.Level (dBm)	Cable loss	Gain (dBi)	PMeas E.R.P(dBm)	Polarization	
								Of Max. ERP	
QPSK	1	0	Lowest	10.55	2.37	10.40	18.58	Horizontal	Pass
	1	0	Middle	10.53	2.39	10.42	18.56	Horizontal	Pass
	1	0	Highest	10.41	2.40	10.44	18.45	Horizontal	Pass
	1	0	Lowest	11.92	2.37	10.40	19.95	Vertical	Pass
	1	0	Middle	11.83	2.39	10.42	19.86	Vertical	Pass
	1	0	Highest	11.86	2.40	10.44	19.90	Vertical	Pass
16QAM	1	0	Lowest	9.6	2.37	10.40	17.63	Horizontal	Pass
	1	0	Middle	9.53	2.39	10.42	17.56	Horizontal	Pass
	1	0	Highest	9.52	2.40	10.44	17.56	Horizontal	Pass
	1	0	Lowest	10.95	2.37	10.40	18.98	Vertical	Pass
	1	0	Middle	11.03	2.39	10.42	19.06	Vertical	Pass
	1	0	Highest	10.85	2.40	10.44	18.89	Vertical	Pass
Limit	EIRP<2W=33dBm								



Radiated Power (EIRP) for LTE Band 25 / 5M									
Modulation	RB		Channel	Result					Conclusion
	Size	Offset		S G.Level (dBm)	Cable loss	Gain (dBi)	PMeas E.R.P(dBm)	Polarization	
								Of Max. ERP	
QPSK	1	0	Lowest	10.36	2.37	10.40	18.39	Horizontal	Pass
	1	0	Middle	10.3	2.39	10.42	18.33	Horizontal	Pass
	1	0	Highest	10.39	2.40	10.44	18.43	Horizontal	Pass
	1	0	Lowest	11.67	2.37	10.40	19.70	Vertical	Pass
	1	0	Middle	11.66	2.39	10.42	19.69	Vertical	Pass
	1	0	Highest	11.69	2.40	10.44	19.73	Vertical	Pass
16QAM	1	0	Lowest	9.48	2.37	10.40	17.51	Horizontal	Pass
	1	0	Middle	9.44	2.39	10.42	17.47	Horizontal	Pass
	1	0	Highest	9.59	2.40	10.44	17.63	Horizontal	Pass
	1	0	Lowest	10.78	2.37	10.40	18.81	Vertical	Pass
	1	0	Middle	10.75	2.39	10.42	18.78	Vertical	Pass
	1	0	Highest	11.07	2.40	10.44	19.11	Vertical	Pass
Limit	EIRP<2W=33dBm								

Radiated Power (EIRP) for LTE Band 25 / 10M									
Modulation	RB		Channel	Result					Conclusion
	Size	Offset		S G.Level (dBm)	Cable loss	Gain (dBi)	PMeas E.R.P(dBm)	Polarization	
								Of Max. ERP	
QPSK	1	0	Lowest	10.49	2.37	10.40	18.52	Horizontal	Pass
	1	0	Middle	10.37	2.39	10.42	18.40	Horizontal	Pass
	1	0	Highest	10.3	2.40	10.44	18.34	Horizontal	Pass
	1	0	Lowest	11.93	2.37	10.40	19.96	Vertical	Pass
	1	0	Middle	11.81	2.39	10.42	19.84	Vertical	Pass
	1	0	Highest	11.73	2.40	10.44	19.77	Vertical	Pass
16QAM	1	0	Lowest	9.59	2.37	10.40	17.62	Horizontal	Pass
	1	0	Middle	9.71	2.39	10.42	17.74	Horizontal	Pass
	1	0	Highest	9.54	2.40	10.44	17.58	Horizontal	Pass
	1	0	Lowest	11.08	2.37	10.40	19.11	Vertical	Pass
	1	0	Middle	11.04	2.39	10.42	19.07	Vertical	Pass
	1	0	Highest	10.98	2.40	10.44	19.02	Vertical	Pass
Limit	EIRP<2W=33dBm								



Radiated Power (EIRP) for LTE Band 25 / 15M									
Modulation	RB		Channel	Result					Conclusion
	Size	Offset		S G.Level (dBm)	Cable loss	Gain (dBi)	PMeas E.R.P.(dBm)	Polarization	
								Of Max. ERP	
QPSK	1	0	Lowest	10.7	2.37	10.40	18.73	Horizontal	Pass
	1	0	Middle	10.49	2.39	10.42	18.52	Horizontal	Pass
	1	0	Highest	10.54	2.40	10.44	18.58	Horizontal	Pass
	1	0	Lowest	12.18	2.37	10.40	20.21	Vertical	Pass
	1	0	Middle	11.98	2.39	10.42	20.01	Vertical	Pass
	1	0	Highest	11.96	2.40	10.44	20.00	Vertical	Pass
16QAM	1	0	Lowest	10.46	2.37	10.40	18.49	Horizontal	Pass
	1	0	Middle	10.26	2.39	10.42	18.29	Horizontal	Pass
	1	0	Highest	10.36	2.40	10.44	18.40	Horizontal	Pass
	1	0	Lowest	11.9	2.37	10.40	19.93	Vertical	Pass
	1	0	Middle	11.73	2.39	10.42	19.76	Vertical	Pass
	1	0	Highest	11.67	2.40	10.44	19.71	Vertical	Pass
Limit	EIRP<2W=33dBm								

Radiated Power (EIRP) for LTE Band 25 / 20M									
Modulation	RB		Channel	Result					Conclusion
	Size	Offset		S G.Level (dBm)	Cable loss	Gain (dBi)	PMeas E.R.P.(dBm)	Polarization	
								Of Max. ERP	
QPSK	1	0	Lowest	10.65	2.37	10.40	18.68	Horizontal	Pass
	1	0	Middle	10.72	2.39	10.42	18.75	Horizontal	Pass
	1	0	Highest	10.48	2.40	10.44	18.52	Horizontal	Pass
	1	0	Lowest	12.07	2.37	10.40	20.10	Vertical	Pass
	1	0	Middle	12.12	2.39	10.42	20.15	Vertical	Pass
	1	0	Highest	11.96	2.40	10.44	20.00	Vertical	Pass
16QAM	1	0	Lowest	10.65	2.37	10.40	18.68	Horizontal	Pass
	1	0	Middle	10.31	2.39	10.42	18.34	Horizontal	Pass
	1	0	Highest	10.44	2.40	10.44	18.48	Horizontal	Pass
	1	0	Lowest	11.97	2.37	10.40	20.00	Vertical	Pass
	1	0	Middle	11.77	2.39	10.42	19.80	Vertical	Pass
	1	0	Highest	11.78	2.40	10.44	19.82	Vertical	Pass
Limit	EIRP<2W=33dBm								



**LTE Band 26**

Radiated Power (EIRP) for LTE Band 26 / 1.4M									
Modulation	RB		Channel	Result					Conclusion
	Size	Offset		S G.Level (dBm)	Cable loss	Gain (dBi)	PMeas E.R.P(dBm)	Polarization	
								Of Max. ERP	
QPSK	1	0	Lowest	11.12	2.35	10.13	18.90	Horizontal	Pass
	1	0	Middle	11.06	2.36	10.16	18.86	Horizontal	Pass
	1	0	Highest	10.98	2.37	10.22	18.83	Horizontal	Pass
	1	0	Lowest	12.57	2.35	10.13	20.35	Vertical	Pass
	1	0	Middle	12.42	2.36	10.16	20.22	Vertical	Pass
	1	0	Highest	12.41	2.37	10.22	20.26	Vertical	Pass
16QAM	1	0	Lowest	10.12	2.35	10.13	17.90	Horizontal	Pass
	1	0	Middle	10.3	2.36	10.16	18.10	Horizontal	Pass
	1	0	Highest	10.28	2.37	10.22	18.13	Horizontal	Pass
	1	0	Lowest	11.53	2.35	10.13	19.31	Vertical	Pass
	1	0	Middle	11.75	2.36	10.16	19.55	Vertical	Pass
	1	0	Highest	11.76	2.37	10.22	19.61	Vertical	Pass
Limit	EIRP<1W=30dBm								

Radiated Power (EIRP) for LTE Band 26 / 3M									
Modulation	RB		Channel	Result					Conclusion
	Size	Offset		S G.Level (dBm)	Cable loss	Gain (dBi)	PMeas E.R.P(dBm)	Polarization	
								Of Max. ERP	
QPSK	1	0	Lowest	11.24	2.35	10.13	19.02	Horizontal	Pass
	1	0	Middle	11	2.36	10.16	18.80	Horizontal	Pass
	1	0	Highest	10.99	2.37	10.22	18.84	Horizontal	Pass
	1	0	Lowest	12.61	2.35	10.13	20.39	Vertical	Pass
	1	0	Middle	12.47	2.36	10.16	20.27	Vertical	Pass
	1	0	Highest	12.33	2.37	10.22	20.18	Vertical	Pass
16QAM	1	0	Lowest	10.48	2.35	10.13	18.26	Horizontal	Pass
	1	0	Middle	10.35	2.36	10.16	18.15	Horizontal	Pass
	1	0	Highest	10.35	2.37	10.22	18.20	Horizontal	Pass
	1	0	Lowest	11.95	2.35	10.13	19.73	Vertical	Pass
	1	0	Middle	11.84	2.36	10.16	19.64	Vertical	Pass
	1	0	Highest	11.69	2.37	10.22	19.54	Vertical	Pass
Limit	EIRP<1W=30dBm								





Radiated Power (EIRP) for LTE Band 26 / 5M									
Modulation	RB		Channel	Result					Conclusion
	Size	Offset		S G.Level (dBm)	Cable loss	Gain (dBi)	PMeas E.R.P(dBm)	Polarization	
								Of Max. ERP	
QPSK	1	0	Lowest	11.25	2.35	10.13	19.03	Horizontal	Pass
	1	0	Middle	11.19	2.36	10.16	18.99	Horizontal	Pass
	1	0	Highest	10.88	2.37	10.22	18.73	Horizontal	Pass
	1	0	Lowest	12.64	2.35	10.13	20.42	Vertical	Pass
	1	0	Middle	12.51	2.36	10.16	20.31	Vertical	Pass
	1	0	Highest	12.24	2.37	10.22	20.09	Vertical	Pass
16QAM	1	0	Lowest	10.3	2.35	10.13	18.08	Horizontal	Pass
	1	0	Middle	10.1	2.36	10.16	17.90	Horizontal	Pass
	1	0	Highest	10.26	2.37	10.22	18.11	Horizontal	Pass
	1	0	Lowest	11.77	2.35	10.13	19.55	Vertical	Pass
	1	0	Middle	11.55	2.36	10.16	19.35	Vertical	Pass
	1	0	Highest	11.7	2.37	10.22	19.55	Vertical	Pass
Limit	EIRP<1W=30dBm								

Radiated Power (EIRP) for LTE Band 26 / 10M									
Modulation	RB		Channel	Result					Conclusion
	Size	Offset		S G.Level (dBm)	Cable loss	Gain (dBi)	PMeas E.R.P(dBm)	Polarization	
								Of Max. ERP	
QPSK	1	0	Lowest	11.14	2.35	10.13	18.92	Horizontal	Pass
	1	0	Middle	11.13	2.36	10.16	18.93	Horizontal	Pass
	1	0	Highest	10.95	2.37	10.22	18.80	Horizontal	Pass
	1	0	Lowest	12.6	2.35	10.13	20.38	Vertical	Pass
	1	0	Middle	12.6	2.36	10.16	20.40	Vertical	Pass
	1	0	Highest	12.37	2.37	10.22	20.22	Vertical	Pass
16QAM	1	0	Lowest	10.41	2.35	10.13	18.19	Horizontal	Pass
	1	0	Middle	10.22	2.36	10.16	18.02	Horizontal	Pass
	1	0	Highest	10.48	2.37	10.22	18.33	Horizontal	Pass
	1	0	Lowest	11.75	2.35	10.13	19.53	Vertical	Pass
	1	0	Middle	11.71	2.36	10.16	19.51	Vertical	Pass
	1	0	Highest	11.79	2.37	10.22	19.64	Vertical	Pass
Limit	EIRP<1W=30dBm								



Radiated Power (EIRP) for LTE Band 26 / 15M									
Modulation	RB		Channel	Result					Conclusion
	Size	Offset		S G.Level (dBm)	Cable loss	Gain (dBi)	PMeas E.R.P.(dBm)	Polarization	
								Of Max. ERP	
QPSK	1	0	Lowest	11.38	2.35	10.13	19.16	Horizontal	Pass
	1	0	Middle	11.27	2.36	10.16	19.07	Horizontal	Pass
	1	0	Highest	11.19	2.37	10.22	19.04	Horizontal	Pass
	1	0	Lowest	12.87	2.35	10.13	20.65	Vertical	Pass
	1	0	Middle	12.7	2.36	10.16	20.50	Vertical	Pass
	1	0	Highest	12.53	2.37	10.22	20.38	Vertical	Pass
16QAM	1	0	Lowest	11.24	2.35	10.13	19.02	Horizontal	Pass
	1	0	Middle	11.07	2.36	10.16	18.87	Horizontal	Pass
	1	0	Highest	10.88	2.37	10.22	18.73	Horizontal	Pass
	1	0	Lowest	12.59	2.35	10.13	20.37	Vertical	Pass
	1	0	Middle	12.48	2.36	10.16	20.28	Vertical	Pass
	1	0	Highest	12.32	2.37	10.22	20.17	Vertical	Pass
Limit	EIRP<1W=30dBm								



LTE Band 41

Radiated Power (EIRP) for LTE Band 41 / 5M									
Modulation	RB		Channel	Result					Conclusion
	Size	Offset		S G.Level (dBm)	Cable loss	Gain (dBi)	PMeas E.I.R.P(dBm)	Polarization	
								Of Max. EIRP	
QPSK	1	0	Lowest	9.36	2.56	10.60	17.40	Horizontal	Pass
	1	0	Middle	9.54	2.67	10.65	17.52	Horizontal	Pass
	1	0	Highest	9.91	2.72	10.70	17.89	Horizontal	Pass
	1	0	Lowest	10.84	2.56	10.60	18.88	Vertical	Pass
	1	0	Middle	11.03	2.67	10.65	19.01	Vertical	Pass
	1	0	Highest	11.28	2.72	10.70	19.26	Vertical	Pass
16QAM	1	0	Lowest	9.26	2.56	10.60	17.30	Horizontal	Pass
	1	0	Middle	9.12	2.67	10.65	17.10	Horizontal	Pass
	1	0	Highest	9.49	2.72	10.70	17.47	Horizontal	Pass
	1	0	Lowest	10.58	2.56	10.60	18.62	Vertical	Pass
	1	0	Middle	10.59	2.67	10.65	18.57	Vertical	Pass
	1	0	Highest	10.92	2.72	10.70	18.90	Vertical	Pass
Limit	EIRP<2W=33dBm								

Radiated Power (EIRP) for LTE Band 41 / 10M									
Modulation	RB		Channel	Result					Conclusion
	Size	Offset		S G.Level (dBm)	Cable loss	Gain (dBi)	PMeas E.I.R.P(dBm)	Polarization	
								Of Max. EIRP	
QPSK	1	0	Lowest	8.67	2.56	10.60	16.71	Horizontal	Pass
	1	0	Middle	8.71	2.67	10.65	16.69	Horizontal	Pass
	1	0	Highest	8.86	2.72	10.70	16.84	Horizontal	Pass
	1	0	Lowest	10	2.56	10.60	18.04	Vertical	Pass
	1	0	Middle	10.06	2.67	10.65	18.04	Vertical	Pass
	1	0	Highest	10.18	2.72	10.70	18.16	Vertical	Pass
16QAM	1	0	Lowest	8.31	2.56	10.60	16.35	Horizontal	Pass
	1	0	Middle	8.44	2.67	10.65	16.42	Horizontal	Pass
	1	0	Highest	8.66	2.72	10.70	16.64	Horizontal	Pass
	1	0	Lowest	9.78	2.56	10.60	17.82	Vertical	Pass
	1	0	Middle	9.9	2.67	10.65	17.88	Vertical	Pass
	1	0	Highest	10	2.72	10.70	17.98	Vertical	Pass
Limit	EIRP<2W=33dBm								



Radiated Power (EIRP) for LTE Band 41 / 15M									
Modulation	RB		Channel	Result					Conclusion
	Size	Offset		S G.Level (dBm)	Cable loss	Gain (dBi)	PMeas E.I.R.P(dBm)	Polarization	
								Of Max. EIRP	
QPSK	1	0	Lowest	9.45	2.56	10.60	17.49	Horizontal	Pass
	1	0	Middle	9.48	2.67	10.65	17.46	Horizontal	Pass
	1	0	Highest	9.91	2.72	10.70	17.89	Horizontal	Pass
	1	0	Lowest	10.93	2.56	10.60	18.97	Vertical	Pass
	1	0	Middle	10.91	2.67	10.65	18.89	Vertical	Pass
	1	0	Highest	11.31	2.72	10.70	19.29	Vertical	Pass
16QAM	1	0	Lowest	9.28	2.56	10.60	17.32	Horizontal	Pass
	1	0	Middle	9.17	2.67	10.65	17.15	Horizontal	Pass
	1	0	Highest	9.57	2.72	10.70	17.55	Horizontal	Pass
	1	0	Lowest	10.71	2.56	10.60	18.75	Vertical	Pass
	1	0	Middle	10.64	2.67	10.65	18.62	Vertical	Pass
	1	0	Highest	10.92	2.72	10.70	18.90	Vertical	Pass
Limit	EIRP<2W=33dBm								

Radiated Power (EIRP) for LTE Band 41 / 20M									
Modulation	RB		Channel	Result					Conclusion
	Size	Offset		S G.Level (dBm)	Cable loss	Gain (dBi)	PMeas E.I.R.P(dBm)	Polarization	
								Of Max. EIRP	
QPSK	1	0	Lowest	9.6	2.56	10.60	17.64	Horizontal	Pass
	1	0	Middle	9.65	2.67	10.65	17.63	Horizontal	Pass
	1	0	Highest	9.91	2.72	10.70	17.89	Horizontal	Pass
	1	0	Lowest	10.93	2.56	10.60	18.97	Vertical	Pass
	1	0	Middle	10.99	2.67	10.65	18.97	Vertical	Pass
	1	0	Highest	11.29	2.72	10.70	19.27	Vertical	Pass
16QAM	1	0	Lowest	9.28	2.56	10.60	17.32	Horizontal	Pass
	1	0	Middle	9.55	2.67	10.65	17.53	Horizontal	Pass
	1	0	Highest	9.63	2.72	10.70	17.61	Horizontal	Pass
	1	0	Lowest	10.71	2.56	10.60	18.75	Vertical	Pass
	1	0	Middle	10.91	2.67	10.65	18.89	Vertical	Pass
	1	0	Highest	11.07	2.72	10.70	19.05	Vertical	Pass
Limit	EIRP<2W=33dBm								

## 6. OCCUPIED BANDWIDTH

### 6.1 DESCRIPTION OF OCCUPIED BANDWIDTH MEASUREMENT

#### 6.1.1 MEASUREMENT METHOD

1.The occupied bandwidth is the width of a frequency band such that, below the lower and above the upper frequency limits, the mean powers emitted are each equal to a specified percentage 0.5% of the total mean transmitted power.

2.The 26 db emission bandwidth is defined as the frequency range between two points, one above and one below the carrier frequency, at which the spectral density of the emission is attenuated 26 db below the maximum in-band spectral density of the modulated signal. spectral density (power per unit bandwidth) is to be measured with a detector of resolution bandwidth equal to approximately 1.0% of the emission bandwidth.

#### 6.1.2 TEST SETUP

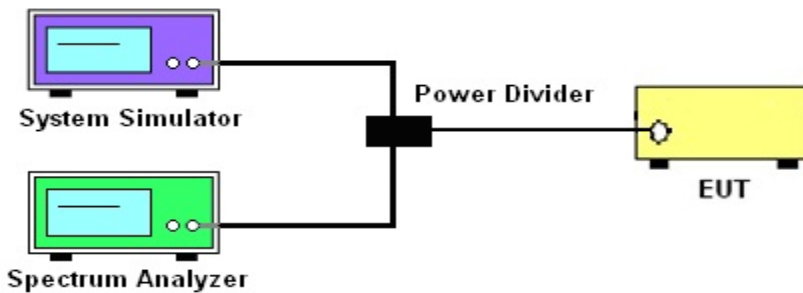

#### 6.1.3 TEST PROCEDURES

1. The testing follows FCC KDB 971168 D01 v03r01 Section 4.1.and 4.2
2. The EUT was connected to spectrum and system simulator via a power divider
3. Select lowest, middle, and highest channels for each band and different modulation.
4. Set the test probe and measure the Occupied Bandwidth of the spectrum analyzer
5. Measure and record the Occupied Bandwidth from the Spectrum Analyzer.

	LTE					
LTE BW	1.4M	3M	5M	10M	15M	20M
Span	3MHz	6MHz	10MHz	20MHz	30MHz	40MHz
RBW	30kHz	30kHz	100kHz	100kHz	300kHz	300kHz
VBW	100kHz	100kHz	300kHz	300kHz	1000kHz	1000kHz
Detector	PK	PK	PK	PK	PK	PK
Trace	Max	Max	Max	Max	Max	Max
Sweep Count	Auto	Auto	Auto	Auto	Auto	Auto



## 6.1.4 MEASUREMENT RESULT

## LTE BAND 2

LTE Band 2 Bandwidth [MHz]							
BW [MHz]	Mod	Lowest		Middle		Highest	
		26dB BW	99% BW	26dB BW	99% BW	26dB BW	99% BW
1.4	QPSK	1.289	1.0911	1.304	1.0984	1.286	1.1033
1.4	16-QAM	1.277	1.0899	1.298	1.0951	1.305	1.0990
3	QPSK	2.854	2.6741	2.878	2.6824	2.869	2.6747
3	16-QAM	2.861	2.6711	2.853	2.6760	2.858	2.6715
5	QPSK	5.218	4.5342	5.130	4.5250	5.192	4.5273
5	16-QAM	5.178	4.5246	5.205	4.5259	5.170	4.5250
10	QPSK	9.910	8.9589	9.923	8.9726	9.869	8.9670
10	16-QAM	9.814	8.9600	9.795	8.9552	9.876	8.9520
15	QPSK	15.11	13.499	15.17	13.530	15.09	13.515
15	16-QAM	15.08	13.546	16.10	13.530	15.01	13.512
20	QPSK	19.37	17.942	19.84	17.979	19.39	17.893
20	16-QAM	19.61	17.948	19.47	17.992	19.46	17.910

## LTE BAND 4

LTE Band 4 Bandwidth [MHz]							
BW [MHz]	Mod	Lowest		Middle		Highest	
		26dB BW	99% BW	26dB BW	99% BW	26dB BW	99% BW
1.4	QPSK	1.280	1.0905	1.308	1.0968	1.279	1.1027
1.4	16-QAM	1.276	1.0888	1.298	1.0930	1.307	1.0987
3	QPSK	2.860	2.6781	2.860	2.6782	2.857	2.6757
3	16-QAM	2.858	2.6719	2.868	2.6723	2.862	2.6759
5	QPSK	5.104	4.5186	5.181	4.5201	5.203	4.5257
5	16-QAM	5.178	4.5210	5.178	4.5177	5.184	4.5262
10	QPSK	9.875	8.9444	9.888	8.9536	9.739	8.9438
10	16-QAM	9.707	8.9523	9.820	8.9475	9.891	8.9490
15	QPSK	15.14	13.513	15.03	13.510	14.91	13.457
15	16-QAM	14.92	13.517	14.97	13.495	15.00	13.506
20	QPSK	19.57	17.929	19.77	17.954	19.38	17.903
20	16-QAM	19.58	17.982	19.68	17.926	19.48	17.895



**LTE BAND 5**

LTE Band 5 Bandwidth [MHz]							
BW [MHz]	Mod	Lowest		Middle		Highest	
		26dB BW	99% BW	26dB BW	99% BW	26dB BW	99% BW
1.4	QPSK	1.305	1.0988	1.279	1.1019	1.280	1.0908
1.4	16-QAM	1.304	1.1000	1.276	1.0892	1.292	1.0955
3	QPSK	2.860	2.6793	2.868	2.6775	2.839	2.6732
3	16-QAM	2.864	2.6738	2.865	2.6760	2.859	2.6699
5	QPSK	5.163	4.5246	5.202	4.5259	5.064	4.5119
5	16-QAM	5.189	4.5215	5.172	4.5216	5.099	4.5139
10	QPSK	9.780	8.9433	9.905	8.9398	9.897	8.9409
10	16-QAM	9.691	8.9494	9.759	8.9382	9.792	8.9326

**LTE BAND 7**

LTE Band 7 Bandwidth [MHz]							
BW [MHz]	Mod	Lowest		Middle		Highest	
		26dB BW	99% BW	26dB BW	99% BW	26dB BW	99% BW
5	QPSK	5.161	4.5183	5.205	4.5275	5.194	4.5244
5	16-QAM	5.319	4.5189	5.180	4.5274	5.196	4.5324
10	QPSK	9.938	8.9553	9.900	8.9449	9.859	8.9526
10	16-QAM	9.744	8.9503	9.795	8.9501	9.888	8.9521
15	QPSK	15.03	13.452	15.20	13.496	15.09	13.541
15	16-QAM	14.96	13.504	15.08	13.506	15.06	13.520
20	QPSK	19.50	17.892	19.77	17.953	19.55	17.942
20	16-QAM	19.64	17.927	19.62	17.943	19.79	17.982

**LTE BAND 12**

LTE Band 12 Bandwidth [MHz]							
BW [MHz]	Mod	Lowest		Middle		Highest	
		26dB BW	99% BW	26dB BW	99% BW	26dB BW	99% BW
1.4	QPSK	1.302	1.0963	1.280	1.1021	1.282	1.0920
1.4	16-QAM	1.292	1.0941	1.307	1.0993	1.272	1.0894
3	QPSK	2.863	2.6761	2.871	2.6812	2.850	2.6741
3	16-QAM	2.858	2.6734	2.868	2.6818	2.857	2.6753
5	QPSK	5.071	4.5152	5.043	4.5282	5.096	4.5214
5	16-QAM	5.041	4.5185	5.080	4.5292	5.086	4.5210
10	QPSK	9.821	8.93666	9.961	8.9700	9.811	8.9306
10	16-QAM	9.791	8.9305	9.867	8.9519	9.678	8.9501

**LTE BAND 13**

LTE Band 13 Bandwidth [MHz]							
BW [MHz]	Mod	Lowest		Middle		Highest	
		26dB BW	99% BW	26dB BW	99% BW	26dB BW	99% BW
5	QPSK	5.143	4.5265	5.202	4.5247	5.135	4.5177
5	16-QAM	5.223	4.5232	5.154	4.5349	5.186	4.5223
10	QPSK	/	/	9.930	8.9484	/	/
10	16-QAM	/	/	9.696	8.9428	/	/

**LTE BAND 17**

LTE Band 17 Bandwidth [MHz]							
BW [MHz]	Mod	Lowest		Middle		Highest	
		26dB BW	99% BW	26dB BW	99% BW	26dB BW	99% BW
5	QPSK	5.132	4.5175	5.182	4.5300	5.184	4.5205
5	16-QAM	5.155	4.5212	5.181	4.5330	5.157	4.5150
10	QPSK	9.899	8.9567	9.905	8.9585	9.776	8.9346
10	16-QAM	9.732	8.9549	9.823	8.9538	9.793	8.9478

**LTE BAND 25**

LTE Band 25 Bandwidth [MHz]							
BW [MHz]	Mod	Lowest		Middle		Highest	
		26dB BW	99% BW	26dB BW	99% BW	26dB BW	99% BW
1.4	QPSK	1.278	1.0925	1.309	1.0957	1.274	1.1011
1.4	16-QAM	1.272	1.2899	1.288	1.0936	1.304	1.0986
3	QPSK	2.862	2.6783	2.846	2.6733	2.855	2.6787
3	16-QAM	2.858	2.6744	2.864	2.6765	2.860	2.6716
5	QPSK	5.159	4.5204	5.202	4.5254	5.144	4.5238
5	16-QAM	5.197	4.5316	5.164	4.5372	5.192	4.5183
10	QPSK	9.945	8.9598	9.773	8.9478	9.788	8.9401
10	16-QAM	9.755	8.9614	9.805	8.9541	9.800	8.9485
15	QPSK	15.14	13.546	15.07	13.537	14.91	13.483
15	16-QAM	15.11	13.537	15.02	13.534	14.97	13.520
20	QPSK	19.69	17.988	19.73	17.979	19.44	17.913
20	16-QAM	19.58	17.936	19.75	17.978	19.43	17.915





**LTE BAND 26**

LTE Band 26 Bandwidth [MHz]							
BW [MHz]	Mod	Lowest		Middle		Highest	
		26dB BW	99% BW	26dB BW	99% BW	26dB BW	99% BW
1.4	QPSK	1.279	1.0925	1.303	1.0964	1.274	1.035
1.4	16-QAM	1.278	1.0895	1.298	1.0943	1.298	1.0997
3	QPSK	2.865	2.6806	2.858	2.6776	2.856	2.6724
3	16-QAM	2.847	2.6731	2.846	2.6759	2.856	2.6713
5	QPSK	5.138	4.5199	5.182	4.5267	5.198	4.5222
5	16-QAM	5.139	4.5188	5.187	4.5256	5.106	4.5092
10	QPSK	9.849	8.9414	9.842	8.9535	9.742	8.9252
10	16-QAM	9.804	8.9447	9.834	8.9396	9.784	8.9284
15	QPSK	14.90	13.470	14.97	13.497	15.07	13.482
15	16-QAM	14.96	13.514	14.91	13.481	14.89	13.479

**LTE BAND 41**

LTE Band 41 Bandwidth [MHz]							
BW [MHz]	Mod	Lowest		Middle		Highest	
		26dB BW	99% BW	26dB BW	99% BW	26dB BW	99% BW
5	QPSK	5.427	4.5467	5.122	4.5271	5.264	4.5415
5	16-QAM	5.181	4.5210	5.143	4.5219	5.277	4.5391
10	QPSK	10.11	8.9549	9.829	8.9539	9.973	8.9617
10	16-QAM	9.725	8.9387	10.04	8.9540	9.695	8.9574
15	QPSK	14.42	13.401	14.59	13.413	14.54	13.418
15	16-QAM	14.69	13.410	14.61	13.413	14.52	13.437
20	QPSK	18.88	17.851	18.93	17.872	19.25	17.881
20	16-QAM	18.96	17.861	19.05	17.866	18.93	17.861

**NOTE:Test chart See Appendix A**



## 7. CONDUCTED BAND EDGE

### 7.1 DESCRIPTION OF CONDUCTED BAND EDGE MEASUREMENT

#### 7.1.1 MEASUREMENT METHOD

##### 1. §22.917(a)

For operations in the 824 – 849 MHz band, the FCC limit is  $43 + 10\log_{10}(P[\text{Watts}])$  dB below the transmitter power  $P(\text{Watts})$  in a 100kHz bandwidth. However, in the 1MHz bands immediately outside and adjacent to the licensee's frequency block, a resolution bandwidth of at least one percent of the emission bandwidth of the fundamental emission of the transmitter may be employed.

##### 2. §24.238 (a)

For operations in the 1850-1910 and 1930-1990 MHz band, the FCC limit is  $43 + 10\log_{10}(P[\text{Watts}])$  dB below the transmitter power  $P(\text{Watts})$  in a 1MHz bandwidth. However, in the 1 MHz bands immediately outside and adjacent to the frequency block a resolution bandwidth of at least one percent of the emission bandwidth of the fundamental emission of the transmitter may be employed

##### 3. §27.53 (h)

For operations in the 1710 – 1755 MHz band, the FCC limit is  $43 + 10\log_{10}(P[\text{Watts}])$  dB below the transmitter power  $P(\text{Watts})$  in a 1 MHz bandwidth. However, in the 1MHz bands immediately outside and adjacent to the licensee's frequency block, a resolution bandwidth of at least one percent of the emission bandwidth of the fundamental emission of the transmitter may be employed.

##### 4. §27.53(m)(4)

For operations in the 2500 MHz ~ 2570 MHz band this section, the attenuation factor shall be not less than  $40 + 10 \log (P)$  dB on all frequencies between the channel edge and 5 megahertz from the channel edge,  $43 + 10 \log (P)$  dB on all frequencies between 5 megahertz and X megahertz from the channel edge, and  $55 + 10 \log (P)$  dB on all frequencies more than X megahertz from the channel edge, where X is the greater of 6 megahertz or the actual emission bandwidth as defined in paragraph (m)(6) of this section. In addition, the attenuation factor shall not be less than  $43 + 10 \log (P)$  dB on all frequencies between 2490.5 MHz and 2496 MHz and  $55 + 10 \log (P)$  dB at or below 2490.5 MHz. Mobile Satellite Service licensees operating on frequencies below 2495 MHz may also submit a documented interference complaint against BRS licensees operating on channel BRS Channel 1 on the same terms and conditions as adjacent channel BRS or EBS licensees.

##### 5. §27.53 (g)

For operations in the 698 -746 MHz band, the FCC limit is  $43 + 10\log_{10}(P[\text{Watts}])$  dB below the transmitter power  $P(\text{Watts})$  in a 100 kHz bandwidth. However, in the 100 kilohertz bands immediately outside and adjacent to a licensee's frequency block, a resolution bandwidth of at least 30 kHz may be employed.

### 7.1.2 TEST SETUP

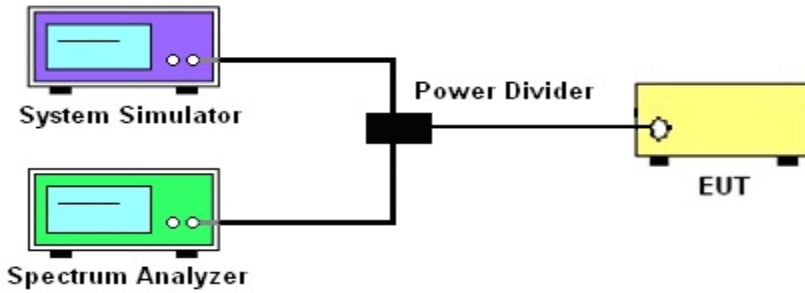

### 7.1.3 TEST PROCEDURES

1. The testing FCC KDB 971168 D01 v03r01 Section 6.0. and ANSI C63.26 2015 Section 5.7.
  2. The EUT was connected to spectrum analyzer and system simulator via a power divider.
  3. The band edges of low and high channels for the highest RF powers were measured. Set RBW  $\geq 1\%$  EBW in the 1MHz band immediately outside and adjacent to the band edge.
  4. Set spectrum analyzer with RMS/AVG detector
  5. The RF fundamental frequency should be excluded against the limit line in the operating frequency band.
  6. The limit line is derived from  $43 + 10\log(P)$  dB below the transmitter power P(Watts)
 
$$= P(W) - [43 + 10\log(P)] \text{ (dB)}$$

$$= [30 + 10\log(P)] \text{ (dBm)} - [43 + 10\log(P)] \text{ (dB)}$$

$$= -13\text{dBm.}$$
- Band 7:
- $$= P(W) - [55 + 10\log(P)] \text{ (dB)}$$
- $$= [30 + 10\log(P)] \text{ (dBm)} - [55 + 10\log(P)] \text{ (dB)}$$
- $$= -25\text{dBm.}$$

	LTE					
LTE BW	1.4M	3M	5M	10M	15M	20M
Span	12MHz	13MHz	15MHz	20MHz	25MHz	30MHz
RBW	30kHz	30kHz	100kHz	100kHz	300kHz	300kHz
VBW	100kHz	100kHz	300kHz	300kHz	1000kHz	1000kHz
Detector	RMS	RMS	RMS	RMS	RMS	RMS
Trace	Max	Max	Max	Max	Max	Max
Sweep Count	Auto	Auto	Auto	Auto	Auto	Auto

### 7.1.4 MEASUREMENT RESULT

NOTE: Test chart See Appendix B

8. CONDUCTED SPURIOUS EMISSION

8.1 DESCRIPTION OF CONDUCTED SPURIOUS EMISSION MEASUREMENT

8.1.1 MEASUREMENT METHOD

The power of any emission outside of the authorized operating frequency ranges must be lower than the transmitter power (P) by a factor of at least 43 + 10 log (P) dB.

For Band 7:

The power of any emission outside of the authorized operating frequency ranges must be lower than the transmitter power (P) by a factor of at least 55 + 10 log (P) dB.

It is measured by means of a calibrated spectrum analyzer and scanned from 30 MHz up to a frequency including its 10th harmonic.

8.1.2 TEST SETUP

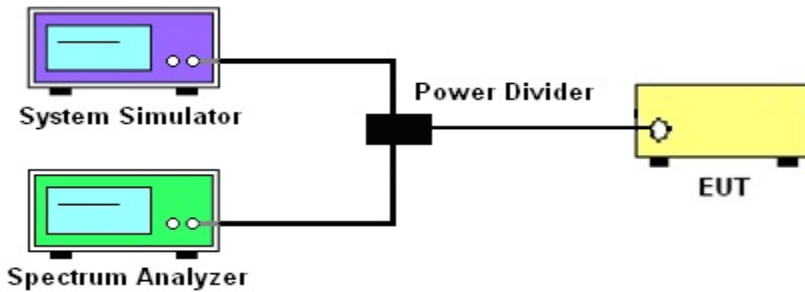

8.1.3 TEST PROCEDURES

1. The testing FCC KDB 971168 D01 v03r01 Section 6.0. and ANSI C63.26 2015 Section 5.7.
2. The EUT was connected to spectrum analyzer and system simulator via a power divider.
3. The RF output of EUT was connected to the spectrum analyzer by RF cable and attenuator. The path loss was compensated to the results for each measurement
4. Make the measurement with the spectrum analyzer's RBW = 1MHz, VBW = 3MHz, taking the record of maximum spurious emission.
5. The RF fundamental frequency should be excluded against the limit line in the operating frequency band.
6. The limit line is derived from  $43 + 10\log(P)$  dB below the transmitter power P(Watts)  
 $= P(W) - [43 + 10\log(P)] \text{ (dB)} = [30 + 10\log(P)] \text{ (dBm)} - [43 + 10\log(P)] \text{ (dB)}$   
 $= -13\text{dBm}$ .  
 For Band 7:  $P(W) - [43 + 10\log(P)] \text{ (dB)} = -25\text{dBm}$

	LTE					
LTE BW	1.4M	3M	5M	10M	15M	20M
Span	Auto	Auto	Auto	Auto	Auto	Auto
RBW	1000kHz	1000kHz	1000kHz	1000kHz	1000kHz	1000kHz
VBW	3000kHz	3000kHz	3000kHz	3000kHz	3000kHz	3000kHz
Detector	PK	PK	PK	PK	PK	PK
Trace	Max	Max	Max	Max	Max	Max

8.1.4 TEST RESULTS

NOTE: Test chart See Appendix C

## 9. RADIATED SPURIOUS EMISSION

### 9.1 DESCRIPTION OF RADIATED SPURIOUS EMISSION

#### 9.1.1 MEASUREMENT METHOD

The radiated spurious emission was measured by substitution method according to ANSI C63.26 2015 . The power of any emission outside of the authorized operating frequency ranges must be attenuated below the transmitter power (P) by a factor of at least  $43 + 10 \log (P)$  dB. For Band 7 The power of any emission outside of the authorized operating frequency ranges must be attenuated below the transmitter power (P) by a factor of at least  $55 + 10 \log (P)$  dB. For Band. The spectrum is scanned from 30 MHz up to a frequency including its 10th harmonic.

#### 5.1.2 Test Setup

The procedure of radiated spurious emissions is as follows:

a) Pre-calibration With pre-calibration method, the Radiated Spurious Emissions(RSE) is calculated as,  $RSE = Rx \text{ (dBuV)} + CL \text{ (dB)} + SA \text{ (dB)} + Gain \text{ (dBi)} - 107 \text{ (dBuV to dBm)}$  The SA is calibrated using following setup.

b) EUT was placed on a 1.5 meter high non-conductive stand at a 3 meter test distance from the receive antenna. A receiving antenna was placed on the antenna mast 3 meters from the test item for emission measurements. The height of receiving antenna is 0.8m. The test setup refers to figure below. Detected emissions were maximized at each frequency by rotating the test item and adjusting the receiving antenna polarization. The radiated emission measurements of all non-harmonic and harmonics of the transmit frequency through the 10th harmonic were measured with peak detector and 1MHz bandwidth.

Radiated emissions measurements were made only at the upper, middle, and lower carrier frequencies It was decided that measurements at these three carrier frequencies would be sufficient to demonstrate compliance with emissions limits because it was seen that all the significant spurs occur well outside the band and no radiation was seen from a carrier in one block of any band into any of the other blocks.

The substitution method is used. Substitution values at each frequency are measured before and saved to the test software. A "reference path loss" is established and the ARpl is the attenuation of "reference path loss", and including the gain of receive antenna, the gain of the preamplifier, the cable loss and the air loss. The measurement results are obtained as described below:  $Power = P_{Mea} + ARpl$

For radiated test from 30MHz to 1GHz

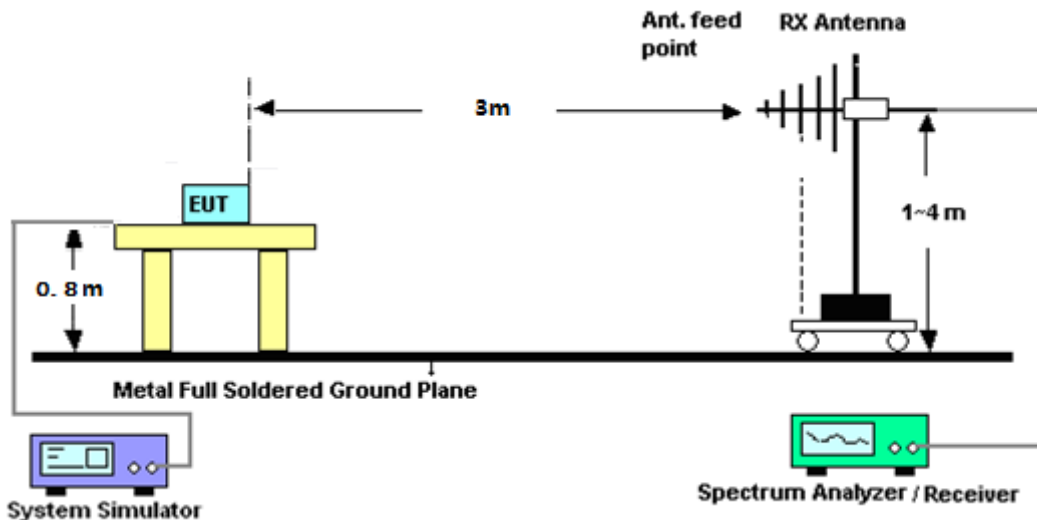

For radiated test from above 1GHz

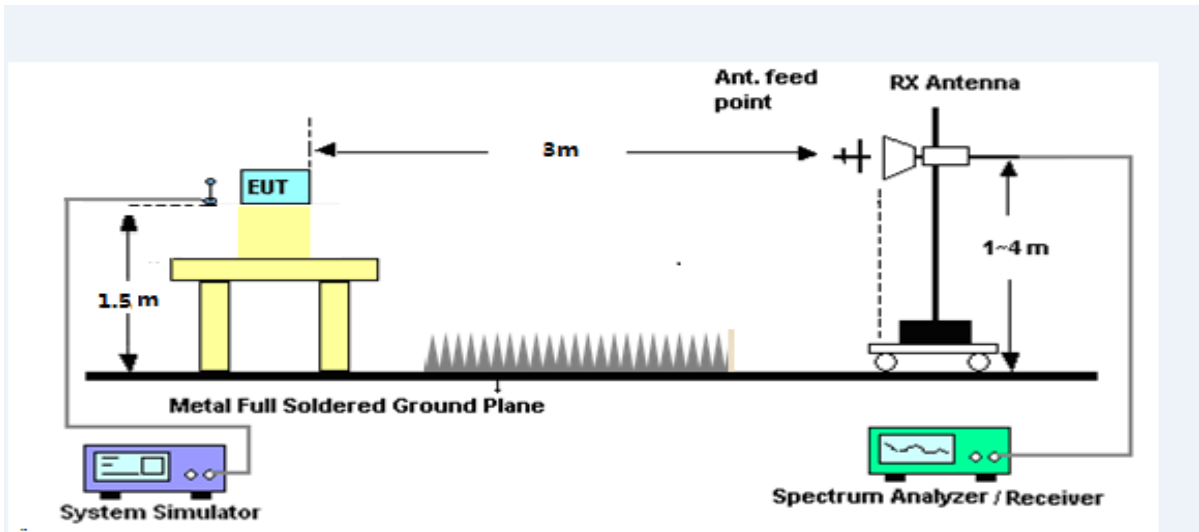

### 9.1.3 TEST PROCEDURES

1. The testing FCC KDB 971168 D01 Section 5.8 and ANSI C63.26 2015 Section 5.5.
2. The EUT was placed on a rotatable wooden table with 0.8 meter above ground.
3. The EUT was set 3 meters from the receiving antenna, which was mounted on the antenna tower.
4. The table was rotated 360 degrees to determine the position of the highest spurious emission.
5. The height of the receiving antenna is varied between one meter and four meters to search the maximum spurious emission for both horizontal and vertical polarizations
6. Make the measurement with the spectrum analyzer's RBW = 1MHz, VBW = 3MHz, taking the record of maximum spurious emission.
7. A horn antenna was substituted in place of the EUT and was driven by a signal generator.
8. Tune the output power of signal generator to the same emission level with EUT maximum spurious emission.
9. Taking the record of output power at antenna port.
10. Repeat step 7 to step 8 for another polarization.
11. The RF fundamental frequency should be excluded against the limit line in the operating frequency band.

The limit line is derived from  $43 + 10\log(P)$ dB below the transmitter power P(Watts)  
 $= P(W) - [43 + 10\log(P)]$  (dB)  
 $= [30 + 10\log(P)]$  (dBm) -  $[43 + 10\log(P)]$  (dB)  
 $= -13$ dBm

For Band 7:

The limit line is derived from  $55 + 10\log(P)$ dB below the transmitter power P(Watts)  
 $= [30 + 10\log(P)]$  (dBm) -  $[55 + 10\log(P)]$  (dB)  
 $= -25$ dBm

EIRP (dBm) = S.G. Power – Tx Cable Loss + Tx Antenna Gain

ERP (dBm) = EIRP - 2.15



9.1.4 TEST RESULTS

**LTE BAND 2**

LTE Band 2 / 1.4MHz / QPSK / RB Size 1 Offset 0/ The Worst Test Results for Lowest							
Frequency(MHz)	S G.Lev (dBm)	Ant(dBi)	Loss	PMea	Limit	Margin	Polarity
				(dBm)	(dBm)	(dBm)	
3701.36	-34.83	12.60	12.93	-35.16	-13.00	-22.16	H
5551.69	-35.24	13.10	17.11	-39.25	-13.00	-26.25	H
7402.79	-32.99	11.50	22.20	-43.69	-13.00	-30.69	H
3701.36	-35.92	12.60	12.93	-36.25	-13.00	-23.25	V
5551.69	-33.83	13.10	17.11	-37.84	-13.00	-24.84	V
7402.79	-32.87	11.50	22.20	-43.57	-13.00	-30.57	V
LTE Band 2 / 1.4MHz / QPSK / RB Size 1 Offset 0/ The Worst Test Results for Middle							
Frequency(MHz)	S G.Lev (dBm)	Ant(dBi)	Loss	PMea	Limit	Margin	Polarity
				(dBm)	(dBm)	(dBm)	
3759.79	-34.85	12.60	12.93	-35.18	-13.00	-22.18	H
5639.84	-34.69	13.10	17.11	-38.70	-13.00	-25.70	H
7519.96	-33.27	11.50	22.20	-43.97	-13.00	-30.97	H
3759.79	-35.49	12.60	12.93	-35.82	-13.00	-22.82	V
5639.84	-33.88	13.10	17.11	-37.89	-13.00	-24.89	V
7519.96	-32.95	11.50	22.20	-43.65	-13.00	-30.65	V
LTE Band 2 / 1.4MHz / QPSK / RB Size 1 Offset 0/ The Worst Test Results for Highest							
Frequency(MHz)	S G.Lev (dBm)	Ant(dBi)	Loss	PMea	Limit	Margin	Polarity
				(dBm)	(dBm)	(dBm)	
3818.40	-34.16	12.60	12.93	-34.49	-13.00	-21.49	H
5727.85	-34.43	13.10	17.11	-38.44	-13.00	-25.44	H
7637.06	-33.15	11.50	22.20	-43.85	-13.00	-30.85	H
3818.40	-35.87	12.60	12.93	-36.20	-13.00	-23.20	V
5727.85	-35.02	13.10	17.11	-39.03	-13.00	-26.03	V
7637.06	-31.98	11.50	22.20	-42.68	-13.00	-29.68	V

Remark: Spurious emissions within 30-1000MHz were found more than 20dB below limit line.

Test is divided into three directions, X/Y/Z. X pattern for the worst.



**LTE BAND 2**

<b>LTE Band 2 / 3MHz / QPSK / RB Size 1 Offset 0/ The Worst Test Results for Lowest</b>							
Frequency(MHz)	S G.Lev (dBm)	Ant(dBi)	Loss	PMea	Limit	Margin	Polarity
				(dBm)	(dBm)	(dBm)	
3703.00	-34.49	12.60	12.93	-34.82	-13.00	-21.82	H
5554.30	-34.40	13.10	17.11	-38.41	-13.00	-25.41	H
7406.68	-32.93	11.50	22.20	-43.63	-13.00	-30.63	H
3703.00	-35.87	12.60	12.93	-36.20	-13.00	-23.20	V
5554.30	-34.45	13.10	17.11	-38.46	-13.00	-25.46	V
7406.68	-32.51	11.50	22.20	-43.21	-13.00	-30.21	V
<b>LTE Band 2 / 3MHz / QPSK / RB Size 1 Offset 0/ The Worst Test Results for Middle</b>							
Frequency(MHz)	S G.Lev (dBm)	Ant(dBi)	Loss	PMea	Limit	Margin	Polarity
				(dBm)	(dBm)	(dBm)	
3759.85	-34.71	12.60	12.93	-35.04	-13.00	-22.04	H
5639.98	-34.48	13.10	17.11	-38.49	-13.00	-25.49	H
7520.08	-32.38	11.50	22.20	-43.08	-13.00	-30.08	H
3759.85	-35.51	12.60	12.93	-35.84	-13.00	-22.84	V
5639.98	-34.34	13.10	17.11	-38.35	-13.00	-25.35	V
7520.08	-31.88	11.50	22.20	-42.58	-13.00	-29.58	V
<b>LTE Band 2 / 3MHz / QPSK / RB Size 1 Offset 0/ The Worst Test Results for Highest</b>							
Frequency(MHz)	S G.Lev (dBm)	Ant(dBi)	Loss	PMea	Limit	Margin	Polarity
				(dBm)	(dBm)	(dBm)	
3816.55	-34.10	12.60	12.93	-34.43	-13.00	-21.43	H
5725.04	-34.49	13.10	17.11	-38.50	-13.00	-25.50	H
7633.29	-32.15	11.50	22.20	-42.85	-13.00	-29.85	H
3816.55	-35.94	12.60	12.93	-36.27	-13.00	-23.27	V
5725.04	-33.77	13.10	17.11	-37.78	-13.00	-24.78	V
7633.29	-32.38	11.50	22.20	-43.08	-13.00	-30.08	V

Remark: Spurious emissions within 30-1000MHz were found more than 20dB below limit line.

Test is divided into three directions, X/Y/Z. X pattern for the worst.





**LTE BAND 2**

LTE Band 2 / 5MHz / QPSK / RB Size 1 Offset 0/ The Worst Test Results for Lowest							
Frequency(MHz)	S G.Lev (dBm)	Ant(dBi)	Loss	PMea	Limit	Margin	Polarity
				(dBm)	(dBm)	(dBm)	
3705.48	-33.97	12.60	12.93	-34.30	-13.00	-21.30	H
5558.01	-34.03	13.10	17.11	-38.04	-13.00	-25.04	H
7410.67	-33.64	11.50	22.20	-44.34	-13.00	-31.34	H
3705.48	-34.77	12.60	12.93	-35.10	-13.00	-22.10	V
5558.01	-33.87	13.10	17.11	-37.88	-13.00	-24.88	V
7410.67	-32.88	11.50	22.20	-43.58	-13.00	-30.58	V
LTE Band 2 / 5MHz / QPSK / RB Size 1 Offset 0/ The Worst Test Results for Middle							
Frequency(MHz)	S G.Lev (dBm)	Ant(dBi)	Loss	PMea	Limit	Margin	Polarity
				(dBm)	(dBm)	(dBm)	
3760.17	-34.35	12.60	12.93	-34.68	-13.00	-21.68	H
5640.13	-34.33	13.10	17.11	-38.34	-13.00	-25.34	H
7520.18	-32.58	11.50	22.20	-43.28	-13.00	-30.28	H
3760.17	-35.79	12.60	12.93	-36.12	-13.00	-23.12	V
5640.13	-34.53	13.10	17.11	-38.54	-13.00	-25.54	V
7520.18	-31.86	11.50	22.20	-42.56	-13.00	-29.56	V
LTE Band 2 / 5MHz / QPSK / RB Size 1 Offset 0/ The Worst Test Results for Highest							
Frequency(MHz)	S G.Lev (dBm)	Ant(dBi)	Loss	PMea	Limit	Margin	Polarity
				(dBm)	(dBm)	(dBm)	
3814.01	-34.00	12.60	12.93	-34.33	-13.00	-21.33	H
5721.26	-34.88	13.10	17.11	-38.89	-13.00	-25.89	H
7628.57	-32.39	11.50	22.20	-43.09	-13.00	-30.09	H
3814.01	-35.03	12.60	12.93	-35.36	-13.00	-22.36	V
5721.26	-34.57	13.10	17.11	-38.58	-13.00	-25.58	V
7628.57	-32.73	11.50	22.20	-43.43	-13.00	-30.43	V

Remark: Spurious emissions within 30-1000MHz were found more than 20dB below limit line.

Test is divided into three directions, X/Y/Z. X pattern for the worst.



**LTE BAND 2**

<b>LTE Band 2 / 10MHz / QPSK / RB Size 1 Offset 0/ The Worst Test Results for Lowest</b>							
Frequency(MHz)	S G.Lev (dBm)	Ant(dBi)	Loss	PMea	Limit	Margin	Polarity
				(dBm)	(dBm)	(dBm)	
3710.54	-33.99	12.60	12.93	-34.32	-13.00	-21.32	H
5565.51	-35.24	13.10	17.11	-39.25	-13.00	-26.25	H
7421.11	-32.69	11.50	22.20	-43.39	-13.00	-30.39	H
3710.54	-34.61	12.60	12.93	-34.94	-13.00	-21.94	V
5565.51	-35.06	13.10	17.11	-39.07	-13.00	-26.07	V
7421.11	-32.48	11.50	22.20	-43.18	-13.00	-30.18	V
<b>LTE Band 2 / 10MHz / QPSK / RB Size 1 Offset 0/ The Worst Test Results for Middle</b>							
Frequency(MHz)	S G.Lev (dBm)	Ant(dBi)	Loss	PMea	Limit	Margin	Polarity
				(dBm)	(dBm)	(dBm)	
3760.16	-34.42	12.60	12.93	-34.75	-13.00	-21.75	H
5639.89	-35.31	13.10	17.11	-39.32	-13.00	-26.32	H
7520.06	-33.36	11.50	22.20	-44.06	-13.00	-31.06	H
3760.16	-35.75	12.60	12.93	-36.08	-13.00	-23.08	V
5639.89	-34.39	13.10	17.11	-38.40	-13.00	-25.40	V
7520.06	-33.02	11.50	22.20	-43.72	-13.00	-30.72	V
<b>LTE Band 2 / 10MHz / QPSK / RB Size 1 Offset 0/ The Worst Test Results for Highest</b>							
Frequency(MHz)	S G.Lev (dBm)	Ant(dBi)	Loss	PMea	Limit	Margin	Polarity
				(dBm)	(dBm)	(dBm)	
3809.14	-33.83	12.60	12.93	-34.16	-13.00	-21.16	H
5714.05	-34.57	13.10	17.11	-38.58	-13.00	-25.58	H
7617.84	-32.73	11.50	22.20	-43.43	-13.00	-30.43	H
3809.14	-34.88	12.60	12.93	-35.21	-13.00	-22.21	V
5714.05	-35.04	13.10	17.11	-39.05	-13.00	-26.05	V
7617.84	-33.17	11.50	22.20	-43.87	-13.00	-30.87	V

Remark: Spurious emissions within 30-1000MHz were found more than 20dB below limit line.

Test is divided into three directions, X/Y/Z. X pattern for the worst.



**LTE BAND 2**

LTE Band 2 / 15MHz / QPSK / RB Size 1 Offset 0/ The Worst Test Results for Lowest							
Frequency(MHz)	S G.Lev (dBm)	Ant(dBi)	Loss	PMea	Limit	Margin	Polarity
				(dBm)	(dBm)	(dBm)	
3716.04	-34.13	12.60	12.93	-34.46	-13.00	-21.46	H
5574.21	-34.44	13.10	17.11	-38.45	-13.00	-25.45	H
7618.78	-32.27	11.50	22.20	-42.97	-13.00	-29.97	H
3716.04	-34.84	12.60	12.93	-35.17	-13.00	-22.17	V
5574.21	-34.78	13.10	17.11	-38.79	-13.00	-25.79	V
7618.78	-32.59	11.50	22.20	-43.29	-13.00	-30.29	V
LTE Band 2 / 15MHz / QPSK / RB Size 1 Offset 0/ The Worst Test Results for Middle							
Frequency(MHz)	S G.Lev (dBm)	Ant(dBi)	Loss	PMea	Limit	Margin	Polarity
				(dBm)	(dBm)	(dBm)	
3759.94	-34.56	12.60	12.93	-34.89	-13.00	-21.89	H
5640.26	-34.10	13.10	17.11	-38.11	-13.00	-25.11	H
7519.89	-33.47	11.50	22.20	-44.17	-13.00	-31.17	H
3759.94	-34.83	12.60	12.93	-35.16	-13.00	-22.16	V
5640.26	-33.98	13.10	17.11	-37.99	-13.00	-24.99	V
7519.89	-31.90	11.50	22.20	-42.60	-13.00	-29.60	V
LTE Band 2 / 15MHz / QPSK / RB Size 1 Offset 0/ The Worst Test Results for Highest							
Frequency(MHz)	S G.Lev (dBm)	Ant(dBi)	Loss	PMea	Limit	Margin	Polarity
				(dBm)	(dBm)	(dBm)	
3803.80	-33.47	12.60	12.93	-33.80	-13.00	-20.80	H
5705.51	-35.22	13.10	17.11	-39.23	-13.00	-26.23	H
7607.23	-33.04	11.50	22.20	-43.74	-13.00	-30.74	H
3803.80	-34.57	12.60	12.93	-34.90	-13.00	-21.90	V
5705.51	-34.55	13.10	17.11	-38.56	-13.00	-25.56	V
7607.23	-32.93	11.50	22.20	-43.63	-13.00	-30.63	V

Remark: Spurious emissions within 30-1000MHz were found more than 20dB below limit line.

Test is divided into three directions, X/Y/Z. X pattern for the worst.



## LTE BAND 2

LTE Band 2 / 20MHz / QPSK / RB Size 1 Offset 0/ The Worst Test Results for Lowest							
Frequency(MHz)	S G.Lev (dBm)	Ant(dBi)	Loss	PMea	Limit	Margin	Polarity
				(dBm)	(dBm)	(dBm)	
3721.03	-34.58	12.60	12.93	-34.91	-13.00	-21.91	H
5581.09	-34.64	13.10	17.11	-38.65	-13.00	-25.65	H
7442.15	-33.07	11.50	22.20	-43.77	-13.00	-30.77	H
3721.03	-35.08	12.60	12.93	-35.41	-13.00	-22.41	V
5581.09	-35.06	13.10	17.11	-39.07	-13.00	-26.07	V
7442.15	-32.34	11.50	22.20	-43.04	-13.00	-30.04	V
LTE Band 2 / 20MHz / QPSK / RB Size 1 Offset 0/ The Worst Test Results for Middle							
Frequency(MHz)	S G.Lev (dBm)	Ant(dBi)	Loss	PMea	Limit	Margin	Polarity
				(dBm)	(dBm)	(dBm)	
3759.81	-34.68	12.60	12.93	-35.01	-13.00	-22.01	H
5640.08	-34.00	13.10	17.11	-38.01	-13.00	-25.01	H
7519.98	-33.20	11.50	22.20	-43.90	-13.00	-30.90	H
3759.81	-34.64	12.60	12.93	-34.97	-13.00	-21.97	V
5640.08	-33.82	13.10	17.11	-37.83	-13.00	-24.83	V
7519.98	-32.18	11.50	22.20	-42.88	-13.00	-29.88	V
LTE Band 2 / 20MHz / QPSK / RB Size 1 Offset 0/ The Worst Test Results for Highest							
Frequency(MHz)	S G.Lev (dBm)	Ant(dBi)	Loss	PMea	Limit	Margin	Polarity
				(dBm)	(dBm)	(dBm)	
3798.40	-34.10	12.60	12.93	-34.43	-13.00	-21.43	H
5697.56	-34.76	13.10	17.11	-38.77	-13.00	-25.77	H
7597.12	-32.29	11.50	22.20	-42.99	-13.00	-29.99	H
3798.40	-35.78	12.60	12.93	-36.11	-13.00	-23.11	V
5697.56	-34.36	13.10	17.11	-38.37	-13.00	-25.37	V
7597.12	-32.14	11.50	22.20	-42.84	-13.00	-29.84	V

Remark: Spurious emissions within 30-1000MHz were found more than 20dB below limit line.

Test is divided into three directions, X/Y/Z. X pattern for the worst.



**LTE BAND 4**

LTE Band 4 / 1.4MHz / QPSK / RB Size 1 Offset 0/ The Worst Test Results for Lowest							
Frequency(MHz)	S G.Lev (dBm)	Ant(dBi)	Loss	PMea	Limit	Margin	Polarity
				(dBm)	(dBm)	(dBm)	
3422.24	-34.24	12.90	12.56	-33.90	-13.00	-20.90	H
5133.34	-34.59	13.10	12.46	-33.95	-13.00	-20.95	H
6844.68	-33.40	12.33	21.13	-42.20	-13.00	-29.20	H
3422.24	-36.01	12.90	12.76	-35.87	-13.00	-22.87	V
5133.34	-33.98	13.10	16.32	-37.20	-13.00	-24.20	V
6844.68	-32.53	12.33	21.13	-41.33	-13.00	-28.33	V
LTE Band 4 / 1.4MHz / QPSK / RB Size 1 Offset 0/ The Worst Test Results for Middle							
Frequency(MHz)	S G.Lev (dBm)	Ant(dBi)	Loss	PMea	Limit	Margin	Polarity
				(dBm)	(dBm)	(dBm)	
3465.91	-33.58	12.80	12.56	-33.34	-13.00	-20.34	H
5199.20	-34.44	13.10	12.46	-33.80	-13.00	-20.80	H
6931.82	-32.69	12.33	21.13	-41.49	-13.00	-28.49	H
3465.91	-35.28	12.80	12.76	-35.24	-13.00	-22.24	V
5199.20	-34.35	13.10	16.32	-37.57	-13.00	-24.57	V
6931.82	-33.20	12.33	21.13	-42.00	-13.00	-29.00	V
LTE Band 4 / 1.4MHz / QPSK / RB Size 1 Offset 0/ The Worst Test Results for Highest							
Frequency(MHz)	S G.Lev (dBm)	Ant(dBi)	Loss	PMea	Limit	Margin	Polarity
				(dBm)	(dBm)	(dBm)	
3508.70	-34.32	12.61	12.56	-34.27	-13.00	-21.27	H
5262.35	-35.00	13.12	12.46	-34.34	-13.00	-21.34	H
7015.87	-32.22	12.32	21.13	-41.03	-13.00	-28.03	H
3508.70	-35.80	12.61	12.76	-35.95	-13.00	-22.95	V
5262.35	-35.22	13.12	16.32	-38.42	-13.00	-25.42	V
7015.87	-32.08	12.32	21.13	-40.89	-13.00	-27.89	V

Remark: Spurious emissions within 30-1000MHz were found more than 20dB below limit line.

Test is divided into three directions, X/Y/Z. X pattern for the worst.



**LTE BAND 4**

LTE Band 4 / 3MHz / QPSK / RB Size 1 Offset 0/ The Worst Test Results for Lowest							
Frequency(MHz)	S G.Lev (dBm)	Ant(dBi)	Loss	PMea	Limit	Margin	Polarity
				(dBm)	(dBm)	(dBm)	
3424.40	-33.90	12.90	12.56	-33.56	-13.00	-20.56	H
5136.67	-35.48	13.10	12.46	-34.84	-13.00	-21.84	H
6848.51	-32.99	12.33	21.13	-41.79	-13.00	-28.79	H
3424.40	-35.98	12.90	12.76	-35.84	-13.00	-22.84	V
5136.67	-34.88	13.10	16.32	-38.10	-13.00	-25.10	V
6848.51	-31.91	12.33	21.13	-40.71	-13.00	-27.71	V
LTE Band 4 / 3MHz / QPSK / RB Size 1 Offset 0/ The Worst Test Results for Middle							
Frequency(MHz)	S G.Lev (dBm)	Ant(dBi)	Loss	PMea	Limit	Margin	Polarity
				(dBm)	(dBm)	(dBm)	
3466.26	-33.59	12.80	12.56	-33.35	-13.00	-20.35	H
5199.08	-35.23	13.10	12.46	-34.59	-13.00	-21.59	H
6932.08	-33.42	12.33	21.13	-42.22	-13.00	-29.22	H
3466.26	-34.97	12.80	12.76	-34.93	-13.00	-21.93	V
5199.08	-34.56	13.10	16.32	-37.78	-13.00	-24.78	V
6932.08	-32.07	12.33	21.13	-40.87	-13.00	-27.87	V
LTE Band 4 / 3MHz / QPSK / RB Size 1 Offset 0/ The Worst Test Results for Highest							
Frequency(MHz)	S G.Lev (dBm)	Ant(dBi)	Loss	PMea	Limit	Margin	Polarity
				(dBm)	(dBm)	(dBm)	
3506.42	-34.00	12.61	12.56	-33.95	-13.00	-20.95	H
5262.29	-34.10	13.12	12.46	-33.44	-13.00	-20.44	H
7013.02	-33.42	12.32	21.13	-42.23	-13.00	-29.23	H
3506.42	-34.82	12.61	12.76	-34.97	-13.00	-21.97	V
5262.29	-34.70	13.12	16.32	-37.90	-13.00	-24.90	V
7013.02	-33.17	12.32	21.13	-41.98	-13.00	-28.98	V

Remark: Spurious emissions within 30-1000MHz were found more than 20dB below limit line.

Test is divided into three directions, X/Y/Z. X pattern for the worst.



**LTE BAND 4**

LTE Band 4 / 5MHz / QPSK / RB Size 1 Offset 0/ The Worst Test Results for Lowest							
Frequency(MHz)	S G.Lev (dBm)	Ant(dBi)	Loss	PMea	Limit	Margin	Polarity
				(dBm)	(dBm)	(dBm)	
3426.30	-34.87	12.90	12.56	-34.53	-13.00	-21.53	H
5139.56	-34.60	13.10	12.46	<b>-33.96</b>	-13.00	-20.96	H
6852.77	-32.79	12.33	21.13	-41.59	-13.00	-28.59	H
3426.30	-35.18	12.90	12.76	-35.04	-13.00	-22.04	V
5139.56	-34.34	13.10	16.32	-37.56	-13.00	-24.56	V
6852.77	-32.64	12.33	21.13	-41.44	-13.00	-28.44	V
LTE Band 4 / 5MHz / QPSK / RB Size 1 Offset 0/ The Worst Test Results for Middle							
Frequency(MHz)	S G.Lev (dBm)	Ant(dBi)	Loss	PMea	Limit	Margin	Polarity
				(dBm)	(dBm)	(dBm)	
3466.13	-34.53	12.80	12.56	-34.29	-13.00	-21.29	H
5199.09	-34.43	13.10	12.46	<b>-33.79</b>	-13.00	-20.79	H
6932.19	-32.24	12.33	21.13	-41.04	-13.00	-28.04	H
3466.13	-34.88	12.80	12.76	-34.84	-13.00	-21.84	V
5199.09	-34.67	13.10	16.32	-37.89	-13.00	-24.89	V
6932.19	-32.04	12.33	21.13	-40.84	-13.00	-27.84	V
LTE Band 4 / 5MHz / QPSK / RB Size 1 Offset 0/ The Worst Test Results for Highest							
Frequency(MHz)	S G.Lev (dBm)	Ant(dBi)	Loss	PMea	Limit	Margin	Polarity
				(dBm)	(dBm)	(dBm)	
3506.37	-33.49	12.61	12.56	<b>-33.44</b>	-13.00	-20.44	H
5262.48	-34.45	13.12	12.46	-33.79	-13.00	-20.79	H
7013.24	-32.90	12.32	21.13	-41.71	-13.00	-28.71	H
3506.37	-35.98	12.61	12.76	-36.13	-13.00	-23.13	V
5262.48	-35.07	13.12	16.32	-38.27	-13.00	-25.27	V
7013.24	-32.86	12.32	21.13	-41.67	-13.00	-28.67	V

Remark: Spurious emissions within 30-1000MHz were found more than 20dB below limit line.

Test is divided into three directions, X/Y/Z. X pattern for the worst.



**LTE BAND 4**

<b>LTE Band 4 / 10MHz / QPSK / RB Size 1 Offset 0/ The Worst Test Results for Lowest</b>							
Frequency(MHz)	S G.Lev (dBm)	Ant(dBi)	Loss	PMea	Limit	Margin	Polarity
				(dBm)	(dBm)	(dBm)	
3436.42	-33.68	12.90	12.56	-33.34	-13.00	-20.34	H
5154.23	-34.37	13.10	12.46	-33.73	-13.00	-20.73	H
6872.74	-33.42	12.33	21.13	-42.22	-13.00	-29.22	H
3436.42	-35.99	12.90	12.76	-35.85	-13.00	-22.85	V
5154.23	-34.05	13.10	16.32	-37.27	-13.00	-24.27	V
6872.74	-32.50	12.33	21.13	-41.30	-13.00	-28.30	V
<b>LTE Band 4 / 10MHz / QPSK / RB Size 1 Offset 0/ The Worst Test Results for Middle</b>							
Frequency(MHz)	S G.Lev (dBm)	Ant(dBi)	Loss	PMea	Limit	Margin	Polarity
				(dBm)	(dBm)	(dBm)	
3465.85	-33.45	12.80	12.56	-33.21	-13.00	-20.21	H
5199.09	-34.64	13.10	12.46	-34.00	-13.00	-21.00	H
6932.05	-32.84	12.33	21.13	-41.64	-13.00	-28.64	H
3465.85	-34.62	12.80	12.76	-34.58	-13.00	-21.58	V
5199.09	-34.54	13.10	16.32	-37.76	-13.00	-24.76	V
6932.05	-33.02	12.33	21.13	-41.82	-13.00	-28.82	V
<b>LTE Band 4 / 10MHz / QPSK / RB Size 1 Offset 0/ The Worst Test Results for Highest</b>							
Frequency(MHz)	S G.Lev (dBm)	Ant(dBi)	Loss	PMea	Limit	Margin	Polarity
				(dBm)	(dBm)	(dBm)	
3494.61	-34.89	12.61	12.56	-34.84	-13.00	-21.84	H
5241.50	-35.34	13.12	12.46	-34.68	-13.00	-21.68	H
6988.19	-32.96	12.32	21.13	-41.77	-13.00	-28.77	H
3494.61	-34.72	12.61	12.76	-34.87	-13.00	-21.87	V
5241.50	-34.21	13.12	16.32	-37.41	-13.00	-24.41	V
6988.19	-32.00	12.32	21.13	-40.81	-13.00	-27.81	V

Remark: Spurious emissions within 30-1000MHz were found more than 20dB below limit line.

Test is divided into three directions, X/Y/Z. X pattern for the worst.





**LTE BAND 4**

LTE Band 4 / 15MHz / QPSK / RB Size 1 Offset 0/ The Worst Test Results for Lowest							
Frequency(MHz)	S G.Lev (dBm)	Ant(dBi)	Loss	PMea	Limit	Margin	Polarity
				(dBm)	(dBm)	(dBm)	
3436.31	-34.44	12.90	12.56	-34.10	-13.00	-21.10	H
5154.47	-34.19	13.10	12.46	<b>-33.55</b>	-13.00	-20.55	H
6872.80	-32.49	12.33	21.13	-41.29	-13.00	-28.29	H
3436.31	-35.54	12.90	12.76	-35.40	-13.00	-22.40	V
5154.47	-34.94	13.10	16.32	-38.16	-13.00	-25.16	V
6872.80	-32.97	12.33	21.13	-41.77	-13.00	-28.77	V
LTE Band 4 / 15MHz / QPSK / RB Size 1 Offset 0/ The Worst Test Results for Middle							
Frequency(MHz)	S G.Lev (dBm)	Ant(dBi)	Loss	PMea	Limit	Margin	Polarity
				(dBm)	(dBm)	(dBm)	
3465.97	-33.71	12.80	12.56	<b>-33.47</b>	-13.00	-20.47	H
5198.85	-34.18	13.10	12.46	-33.54	-13.00	-20.54	H
6932.16	-32.38	12.33	21.13	-41.18	-13.00	-28.18	H
3465.97	-34.85	12.80	12.76	-34.81	-13.00	-21.81	V
5198.85	-34.33	13.10	16.32	-37.55	-13.00	-24.55	V
6932.16	-32.16	12.33	21.13	-40.96	-13.00	-27.96	V
LTE Band 4 / 15MHz / QPSK / RB Size 1 Offset 0/ The Worst Test Results for Highest							
Frequency(MHz)	S G.Lev (dBm)	Ant(dBi)	Loss	PMea	Limit	Margin	Polarity
				(dBm)	(dBm)	(dBm)	
3494.46	-34.41	12.61	12.56	-34.36	-13.00	-21.36	H
5242.19	-34.72	13.12	12.46	<b>-34.06</b>	-13.00	-21.06	H
6989.42	-33.48	12.32	21.13	-42.29	-13.00	-29.29	H
3494.46	-34.66	12.61	12.76	-34.81	-13.00	-21.81	V
5242.19	-34.42	13.12	16.32	-37.62	-13.00	-24.62	V
6989.42	-32.31	12.32	21.13	-41.12	-13.00	-28.12	V

Remark: Spurious emissions within 30-1000MHz were found more than 20dB below limit line.

Test is divided into three directions, X/Y/Z. X pattern for the worst.



**LTE BAND 4**

LTE Band 4 / 20MHz / QPSK / RB Size 1 Offset 0/ The Worst Test Results for Lowest							
Frequency(MHz)	S G.Lev (dBm)	Ant(dBi)	Loss	PMea	Limit	Margin	Polarity
				(dBm)	(dBm)	(dBm)	
3440.27	-34.82	12.90	12.56	-34.48	-13.00	-21.48	H
5160.65	-35.06	13.10	12.46	<b>-34.42</b>	-13.00	-21.42	H
6880.66	-32.35	12.33	21.13	-41.15	-13.00	-28.15	H
3440.27	-35.23	12.90	12.76	-35.09	-13.00	-22.09	V
5160.65	-34.85	13.10	16.32	-38.07	-13.00	-25.07	V
6880.66	-32.80	12.33	21.13	-41.60	-13.00	-28.60	V
LTE Band 4 / 20MHz / QPSK / RB Size 1 Offset 0/ The Worst Test Results for Middle							
Frequency(MHz)	S G.Lev (dBm)	Ant(dBi)	Loss	PMea	Limit	Margin	Polarity
				(dBm)	(dBm)	(dBm)	
3466.08	-34.75	12.80	12.56	-34.51	-13.00	-21.51	H
5199.01	-34.94	13.10	12.46	<b>-34.30</b>	-13.00	-21.30	H
6932.07	-33.05	12.33	21.13	-41.85	-13.00	-28.85	H
3466.08	-35.24	12.80	12.76	-35.20	-13.00	-22.20	V
5199.01	-34.45	13.10	16.32	-37.67	-13.00	-24.67	V
6932.07	-33.04	12.33	21.13	-41.84	-13.00	-28.84	V
LTE Band 4 / 20MHz / QPSK / RB Size 1 Offset 0/ The Worst Test Results for Highest							
Frequency(MHz)	S G.Lev (dBm)	Ant(dBi)	Loss	PMea	Limit	Margin	Polarity
				(dBm)	(dBm)	(dBm)	
3490.76	-34.07	12.61	12.56	-34.02	-13.00	-21.02	H
5235.06	-34.58	13.12	12.46	<b>-33.92</b>	-13.00	-20.92	H
6979.87	-33.65	12.32	21.13	-42.46	-13.00	-29.46	H
3490.76	-35.89	12.61	12.76	-36.04	-13.00	-23.04	V
5235.06	-34.52	13.12	16.32	-37.72	-13.00	-24.72	V
6979.87	-32.65	12.32	21.13	-41.46	-13.00	-28.46	V

Remark: Spurious emissions within 30-1000MHz were found more than 20dB below limit line.

Test is divided into three directions, X/Y/Z. X pattern for the worst.



## LTE BAND 5

LTE Band 5 / 1.4MHz / QPSK / RB Size 1 Offset 0/ The Worst Test Results for Lowest							
Frequency(MHz)	S G.Lev (dBm)	Ant(dBi)	Loss	PMea	Limit	Margin	Polarity
				(dBm)	(dBm)	(dB)	
1649.31	-33.90	9.56	9.72	-34.06	-13.00	-21.06	H
2473.69	-34.99	10.50	10.86	-35.35	-13.00	-22.35	H
3298.54	-32.27	12.78	11.57	-31.06	-13.00	-18.06	H
1649.31	-35.62	9.56	9.34	-35.40	-13.00	-22.40	V
2473.69	-34.94	10.50	10.42	-34.86	-13.00	-21.86	V
3298.54	-32.38	12.78	11.12	-30.72	-13.00	-17.72	V
LTE Band 5 / 1.4MHz / QPSK / RB Size 1 Offset 0/ The Worst Test Results for Middle							
Frequency(MHz)	S G.Lev (dBm)	Ant(dBi)	Loss	PMea	Limit	Margin	Polarity
				(dBm)	(dBm)	(dB)	
1672.98	-34.58	9.56	9.72	-34.74	-13.00	-21.74	H
2509.26	-34.75	10.50	10.86	-35.11	-13.00	-22.11	H
3345.95	-33.62	12.78	11.57	-32.41	-13.00	-19.41	H
1672.98	-35.16	9.56	9.34	-34.94	-13.00	-21.94	V
2509.26	-34.96	10.50	10.42	-34.88	-13.00	-21.88	V
3345.95	-32.20	12.78	11.12	-30.54	-13.00	-17.54	V
LTE Band 5 / 1.4MHz / QPSK / RB Size 1 Offset 0/ The Worst Test Results for Highest							
Frequency(MHz)	S G.Lev (dBm)	Ant(dBi)	Loss	PMea	Limit	Margin	Polarity
				(dBm)	(dBm)	(dB)	
1696.47	-34.67	9.56	9.72	-34.83	-13.00	-21.83	H
2544.55	-34.00	10.50	10.86	-34.36	-13.00	-21.36	H
3393.07	-33.42	12.78	11.57	-32.21	-13.00	-19.21	H
1696.47	-35.36	9.56	9.34	-35.14	-13.00	-22.14	V
2544.55	-34.73	10.50	10.42	-34.65	-13.00	-21.65	V
3393.07	-31.71	12.78	11.12	-30.05	-13.00	-17.05	V

Remark: Spurious emissions within 30-1000MHz were found more than 20dB below limit line.

Test is divided into three directions, X/Y/Z. X pattern for the worst.



LTE BAND 5

LTE Band 5 / 3MHz / QPSK / RB Size 1 Offset 0/ The Worst Test Results for Lowest							
Frequency(MHz)	S G.Lev (dBm)	Ant(dBi)	Loss	PMea	Limit	Margin	Polarity
				(dBm)	(dBm)	(dB)	
1650.69	-33.88	9.56	9.72	-34.04	-13.00	-21.04	H
2476.39	-34.39	10.50	10.86	-34.75	-13.00	-21.75	H
3301.78	-32.53	12.78	11.57	-31.32	-13.00	-18.32	H
1650.69	-35.50	9.56	9.34	-35.28	-13.00	-22.28	V
2476.39	-34.16	10.50	10.42	-34.08	-13.00	-21.08	V
3301.78	-32.92	12.78	11.12	-31.26	-13.00	-18.26	V
LTE Band 5 / 3MHz / QPSK / RB Size 1 Offset 0/ The Worst Test Results for Middle							
Frequency(MHz)	S G.Lev (dBm)	Ant(dBi)	Loss	PMea	Limit	Margin	Polarity
				(dBm)	(dBm)	(dB)	
1672.91	-33.87	9.56	9.72	-34.03	-13.00	-21.03	H
2509.28	-35.18	10.50	10.86	-35.54	-13.00	-22.54	H
3345.75	-32.80	12.78	11.57	-31.59	-13.00	-18.59	H
1672.91	-35.66	9.56	9.34	-35.44	-13.00	-22.44	V
2509.28	-34.06	10.50	10.42	-33.98	-13.00	-20.98	V
3345.75	-32.48	12.78	11.12	-30.82	-13.00	-17.82	V
LTE Band 5 / 3MHz / QPSK / RB Size 1 Offset 0/ The Worst Test Results for Highest							
Frequency(MHz)	S G.Lev (dBm)	Ant(dBi)	Loss	PMea	Limit	Margin	Polarity
				(dBm)	(dBm)	(dB)	
1694.71	-34.76	9.56	9.72	-34.92	-13.00	-21.92	H
2542.27	-35.10	10.50	10.86	-35.46	-13.00	-22.46	H
3389.55	-33.14	12.78	11.57	-31.93	-13.00	-18.93	H
1694.71	-35.55	9.56	9.34	-35.33	-13.00	-22.33	V
2542.27	-34.30	10.50	10.42	-34.22	-13.00	-21.22	V
3389.55	-32.84	12.78	11.12	-31.18	-13.00	-18.18	V

Remark: Spurious emissions within 30-1000MHz were found more than 20dB below limit line.

Test is divided into three directions, X/Y/Z. X pattern for the worst.



LTE BAND 5

LTE Band 5 / 5MHz / QPSK / RB Size 1 Offset 0/ The Worst Test Results for Lowest							
Frequency(MHz)	S G.Lev (dBm)	Ant(dBi)	Loss	PMea	Limit	Margin	Polarity
				(dBm)	(dBm)	(dB)	
1653.00	-33.70	9.56	9.72	-33.86	-13.00	-20.86	H
2479.22	-35.28	10.50	10.86	-35.64	-13.00	-22.64	H
3305.59	-33.33	12.78	11.57	-32.12	-13.00	-19.12	H
1653.00	-35.96	9.56	9.34	-35.74	-13.00	-22.74	V
2479.22	-35.25	10.50	10.42	-35.17	-13.00	-22.17	V
3305.59	-32.79	12.78	11.12	-31.13	-13.00	-18.13	V
LTE Band 5 / 5MHz / QPSK / RB Size 1 Offset 0/ The Worst Test Results for Middle							
Frequency(MHz)	S G.Lev (dBm)	Ant(dBi)	Loss	PMea	Limit	Margin	Polarity
				(dBm)	(dBm)	(dB)	
1672.91	-33.85	9.56	9.72	-34.01	-13.00	-21.01	H
2509.13	-35.29	10.50	10.86	-35.65	-13.00	-22.65	H
3345.82	-33.49	12.78	11.57	-32.28	-13.00	-19.28	H
1672.91	-35.97	9.56	9.34	-35.75	-13.00	-22.75	V
2509.13	-34.19	10.50	10.42	-34.11	-13.00	-21.11	V
3345.82	-33.16	12.78	11.12	-31.50	-13.00	-18.50	V
LTE Band 5 / 5MHz / QPSK / RB Size 1 Offset 0/ The Worst Test Results for Highest							
Frequency(MHz)	S G.Lev (dBm)	Ant(dBi)	Loss	PMea	Limit	Margin	Polarity
				(dBm)	(dBm)	(dB)	
1692.66	-34.90	9.56	9.72	-35.06	-13.00	-22.06	H
2539.38	-35.38	10.50	10.86	-35.74	-13.00	-22.74	H
3385.87	-32.36	12.78	11.57	-31.15	-13.00	-18.15	H
1692.66	-34.98	9.56	9.34	-34.76	-13.00	-21.76	V
2539.38	-34.75	10.50	10.42	-34.67	-13.00	-21.67	V
3385.87	-32.89	12.78	11.12	-31.23	-13.00	-18.23	V

Remark: Spurious emissions within 30-1000MHz were found more than 20dB below limit line.  
 Test is divided into three directions, X/Y/Z. X pattern for the worst.



LTE BAND 5

LTE Band 5 / 10MHz / QPSK / RB Size 1 Offset 0/ The Worst Test Results for Lowest							
Frequency(MHz)	S G.Lev (dBm)	Ant(dBi)	Loss	PMea	Limit	Margin	Polarity
				(dBm)	(dBm)	(dB)	
1657.70	-33.47	9.56	9.72	-33.63	-13.00	-20.63	H
2486.91	-34.07	10.50	10.86	-34.43	-13.00	-21.43	H
3315.98	-32.43	12.78	11.57	-31.22	-13.00	-18.22	H
1657.70	-35.99	9.56	9.34	-35.77	-13.00	-22.77	V
2486.91	-34.07	10.50	10.42	-33.99	-13.00	-20.99	V
3315.98	-32.64	12.78	11.12	-30.98	-13.00	-17.98	V
LTE Band 5 / 10MHz / QPSK / RB Size 1 Offset 0/ The Worst Test Results for Middle							
Frequency(MHz)	S G.Lev (dBm)	Ant(dBi)	Loss	PMea	Limit	Margin	Polarity
				(dBm)	(dBm)	(dB)	
1672.66	-34.59	9.56	9.72	-34.75	-13.00	-21.75	H
2509.18	-35.18	10.50	10.86	-35.54	-13.00	-22.54	H
3345.72	-32.48	12.78	11.57	-31.27	-13.00	-18.27	H
1672.66	-35.93	9.56	9.34	-35.71	-13.00	-22.71	V
2509.18	-35.13	10.50	10.42	-35.05	-13.00	-22.05	V
3345.72	-32.95	12.78	11.12	-31.29	-13.00	-18.29	V
LTE Band 5 / 10MHz / QPSK / RB Size 1 Offset 0/ The Worst Test Results for Highest							
Frequency(MHz)	S G.Lev (dBm)	Ant(dBi)	Loss	PMea	Limit	Margin	Polarity
				(dBm)	(dBm)	(dB)	
1687.91	-34.34	9.56	9.72	-34.50	-13.00	-21.50	H
2531.70	-34.04	10.50	10.86	-34.40	-13.00	-21.40	H
3375.64	-33.59	12.78	11.57	-32.38	-13.00	-19.38	H
1687.91	-34.85	9.56	9.34	-34.63	-13.00	-21.63	V
2531.70	-34.82	10.50	10.42	-34.74	-13.00	-21.74	V
3375.64	-32.40	12.78	11.12	-30.74	-13.00	-17.74	V

Remark: Spurious emissions within 30-1000MHz were found more than 20dB below limit line.  
 Test is divided into three directions, X/Y/Z. X pattern for the worst.



**LTE BAND 7**

LTE Band 7 / 5MHz / QPSK / RB Size 1 Offset 0/ The Worst Test Results for Lowest							
Frequency(MHz)	S G.Lev (dBm)	Ant(dBi)	Loss	PMea	Limit	Margin	Polarity
				(dBm)	(dBm)	(dB)	
5005.49	-34.13	12.66	12.54	-34.01	-25.00	-9.01	H
7507.81	-34.55	11.46	12.57	-35.66	-25.00	-10.66	H
10010.70	-32.37	12.79	21.23	-40.81	-25.00	-15.81	H
5005.49	-34.62	12.66	12.54	-34.50	-25.00	-9.50	V
7507.81	-34.36	11.46	12.57	-35.47	-25.00	-10.47	V
10010.70	-32.13	12.79	21.23	-40.57	-25.00	-15.57	V
LTE Band 7 / 5MHz / QPSK / RB Size 1 Offset 0/ The Worst Test Results for Middle							
Frequency(MHz)	S G.Lev (dBm)	Ant(dBi)	Loss	PMea	Limit	Margin	Polarity
				(dBm)	(dBm)	(dB)	
5069.81	-34.87	12.72	12.55	-34.70	-25.00	-9.70	H
7605.26	-34.94	11.46	12.57	-36.05	-25.00	-11.05	H
10139.91	-32.31	12.09	21.25	-41.47	-25.00	-16.47	H
5069.81	-34.88	12.80	12.55	-34.63	-25.00	-9.63	V
7605.26	-33.86	13.10	12.57	-33.33	-25.00	-8.33	V
10139.91	-31.86	12.33	21.25	-40.78	-25.00	-15.78	V
LTE Band 7 / 5MHz / QPSK / RB Size 1 Offset 0/ The Worst Test Results for Highest							
Frequency(MHz)	S G.Lev (dBm)	Ant(dBi)	Loss	PMea	Limit	Margin	Polarity
				(dBm)	(dBm)	(dB)	
5134.09	-34.31	12.76	12.57	-34.12	-25.00	-9.12	H
7701.30	-34.84	11.45	12.58	-35.97	-25.00	-10.97	H
10268.54	-32.64	12.28	21.27	-41.63	-25.00	-16.63	H
5134.09	-35.51	12.76	12.57	-35.32	-25.00	-10.32	V
7701.30	-34.70	11.45	12.58	-35.83	-25.00	-10.83	V
10268.54	-32.63	12.28	21.27	-41.62	-25.00	-16.62	V

Remark: Spurious emissions within 30-1000MHz were found more than 20dB below limit line.

Test is divided into three directions, X/Y/Z. X pattern for the worst.



**LTE BAND 7**

LTE Band 7 / 10MHz / QPSK / RB Size 1 Offset 0/ The Worst Test Results for Lowest							
Frequency(MHz)	S G.Lev (dBm)	Ant(dBi)	Loss	PMea	Limit	Margin	Polarity
				(dBm)	(dBm)	(dB)	
5010.27	-34.21	12.66	12.54	-34.09	-25.00	-9.09	H
7515.86	-34.31	11.46	12.57	-35.42	-25.00	-10.42	H
10021.21	-33.50	12.79	21.23	-41.94	-25.00	-16.94	H
5010.27	-34.92	12.66	12.54	-34.80	-25.00	-9.80	V
7515.86	-34.49	11.46	12.57	-35.60	-25.00	-10.60	V
10021.21	-32.28	12.79	21.23	-40.72	-25.00	-15.72	V
LTE Band 7 / 10MHz / QPSK / RB Size 1 Offset 0/ The Worst Test Results for Middle							
Frequency(MHz)	S G.Lev (dBm)	Ant(dBi)	Loss	PMea	Limit	Margin	Polarity
				(dBm)	(dBm)	(dB)	
5069.77	-33.61	12.72	12.55	-33.44	-25.00	-8.44	H
7605.02	-35.31	11.46	12.57	-36.42	-25.00	-11.42	H
10139.89	-32.50	12.09	21.25	-41.66	-25.00	-16.66	H
5069.77	-34.60	12.80	12.55	-34.35	-25.00	-9.35	V
7605.02	-34.68	13.10	12.57	-34.15	-25.00	-9.15	V
10139.89	-31.95	12.33	21.25	-40.87	-25.00	-15.87	V
LTE Band 7 / 10MHz / QPSK / RB Size 1 Offset 0/ The Worst Test Results for Highest							
Frequency(MHz)	S G.Lev (dBm)	Ant(dBi)	Loss	PMea	Limit	Margin	Polarity
				(dBm)	(dBm)	(dB)	
5129.35	-33.45	12.76	12.57	-33.26	-25.00	-8.26	H
7694.24	-34.21	11.45	12.58	-35.34	-25.00	-10.34	H
10258.94	-32.28	12.28	21.27	-41.27	-25.00	-16.27	H
5129.35	-34.77	12.76	12.57	-34.58	-25.00	-9.58	V
7694.24	-34.75	11.45	12.58	-35.88	-25.00	-10.88	V
10258.94	-33.04	12.28	21.27	-42.03	-25.00	-17.03	V

Remark: Spurious emissions within 30-1000MHz were found more than 20dB below limit line.

Test is divided into three directions, X/Y/Z. X pattern for the worst.





## LTE BAND 7

LTE Band 7 / 15MHz / QPSK / RB Size 1 Offset 0/ The Worst Test Results for Lowest							
Frequency(MHz)	S G.Lev (dBm)	Ant(dBi)	Loss	PMea	Limit	Margin	Polarity
				(dBm)	(dBm)	(dB)	
5016.13	-34.14	12.66	12.54	-34.02	-25.00	-9.02	H
7524.06	-34.28	11.46	12.57	-35.39	-25.00	-10.39	H
10032.19	-32.48	12.79	21.23	-40.92	-25.00	-15.92	H
5016.13	-34.93	12.66	12.54	-34.81	-25.00	-9.81	V
7524.06	-34.95	11.46	12.57	-36.06	-25.00	-11.06	V
10032.19	-31.93	12.79	21.23	-40.37	-25.00	-15.37	V
LTE Band 7 / 15MHz / QPSK / RB Size 1 Offset 0/ The Worst Test Results for Middle							
Frequency(MHz)	S G.Lev (dBm)	Ant(dBi)	Loss	PMea	Limit	Margin	Polarity
				(dBm)	(dBm)	(dB)	
5070.11	-34.76	12.72	12.55	-34.59	-25.00	-9.59	H
7604.95	-34.42	11.46	12.57	-35.53	-25.00	-10.53	H
10139.92	-32.93	12.09	21.25	-42.09	-25.00	-17.09	H
5070.11	-34.65	12.80	12.55	-34.40	-25.00	-9.40	V
7604.95	-34.32	13.10	12.57	-33.79	-25.00	-8.79	V
10139.92	-32.47	12.33	21.25	-41.39	-25.00	-16.39	V
LTE Band 7 / 15MHz / QPSK / RB Size 1 Offset 0/ The Worst Test Results for Highest							
Frequency(MHz)	S G.Lev (dBm)	Ant(dBi)	Loss	PMea	Limit	Margin	Polarity
				(dBm)	(dBm)	(dB)	
5123.36	-34.57	12.76	12.57	-34.38	-25.00	-9.38	H
7523.92	-35.41	11.45	12.58	-36.54	-25.00	-11.54	H
10032.38	-32.58	12.28	21.27	-41.57	-25.00	-16.57	H
5123.36	-35.12	12.76	12.57	-34.93	-25.00	-9.93	V
7523.92	-34.06	11.45	12.58	-35.19	-25.00	-10.19	V
10032.38	-32.39	12.28	21.27	-41.38	-25.00	-16.38	V

Remark: Spurious emissions within 30-1000MHz were found more than 20dB below limit line.

Test is divided into three directions, X/Y/Z. X pattern for the worst.



**LTE BAND 7**

LTE Band 7 / 20MHz / QPSK / RB Size 1 Offset 0/ The Worst Test Results for Lowest							
Frequency(MHz)	S G.Lev (dBm)	Ant(dBi)	Loss	PMea	Limit	Margin	Polarity
				(dBm)	(dBm)	(dB)	
5021.02	-34.28	12.66	12.54	-34.16	-25.00	-9.16	H
7531.22	-34.62	11.46	12.57	-35.73	-25.00	-10.73	H
7524.32	-33.14	12.79	21.23	-41.58	-25.00	-16.58	H
5021.02	-35.90	12.66	12.54	-35.78	-25.00	-10.78	V
7531.22	-35.02	11.46	12.57	-36.13	-25.00	-11.13	V
7524.32	-33.20	12.79	21.23	-41.64	-25.00	-16.64	V
LTE Band 7 / 20MHz / QPSK / RB Size 1 Offset 0/ The Worst Test Results for Middle							
Frequency(MHz)	S G.Lev (dBm)	Ant(dBi)	Loss	PMea	Limit	Margin	Polarity
				(dBm)	(dBm)	(dB)	
5069.88	-34.13	12.72	12.55	-33.96	-25.00	-8.96	H
7604.87	-34.58	11.46	12.57	-35.69	-25.00	-10.69	H
10140.09	-32.58	12.09	21.25	-41.74	-25.00	-16.74	H
5069.88	-35.47	12.80	12.55	-35.22	-25.00	-10.22	V
7604.87	-34.66	13.10	12.57	-34.13	-25.00	-9.13	V
10140.09	-32.47	12.33	21.25	-41.39	-25.00	-16.39	V
LTE Band 7 / 20MHz / QPSK / RB Size 1 Offset 0/ The Worst Test Results for Highest							
Frequency(MHz)	S G.Lev (dBm)	Ant(dBi)	Loss	PMea	Limit	Margin	Polarity
				(dBm)	(dBm)	(dB)	
5118.75	-33.59	12.76	12.57	-33.40	-25.00	-8.40	H
7678.32	-35.48	11.45	12.58	-36.61	-25.00	-11.61	H
10237.86	-32.58	12.28	21.27	-41.57	-25.00	-16.57	H
5118.75	-35.56	12.76	12.57	-35.37	-25.00	-10.37	V
7678.32	-35.09	11.45	12.58	-36.22	-25.00	-11.22	V
10237.86	-32.31	12.28	21.27	-41.30	-25.00	-16.30	V

Remark: Spurious emissions within 30-1000MHz were found more than 20dB below limit line.  
 Test is divided into three directions, X/Y/Z. X pattern for the worst.



**LTE BAND 12**

<b>LTE Band 12 / 1.4MHz / QPSK / RB Size 1 Offset 0/ The Worst Test Results for Lowest</b>							
Frequency(MHz)	S G.Lev (dBm)	Ant(dBi)	Loss	PMea	Limit	Margin	Polarity
				(dBm)	( dBm )	(dBm)	
1399.20	-34.64	8.17	9.34	-35.81	-13.00	-22.81	H
2098.91	-34.01	9.53	10.42	-34.90	-13.00	-21.90	H
2798.44	-32.29	11.27	11.12	<b>-32.14</b>	-13.00	-19.14	H
1399.20	-35.48	8.17	9.34	-36.65	-13.00	-23.65	V
2098.91	-33.97	9.53	10.42	-34.86	-13.00	-21.86	V
2798.44	-32.72	11.27	11.12	-32.57	-13.00	-19.57	V
<b>LTE Band 12 / 1.4MHz / QPSK / RB Size 1 Offset 0/ The Worst Test Results for Middle</b>							
Frequency(MHz)	S G.Lev (dBm)	Ant(dBi)	Loss	PMea	Limit	Margin	Polarity
				(dBm)	( dBm )	(dBm)	
1414.78	-33.78	8.17	9.34	-34.95	-13.00	-21.95	H
2122.37	-34.38	9.53	10.42	-35.27	-13.00	-22.27	H
2829.87	-33.34	11.27	11.12	-33.19	-13.00	-20.19	H
1414.78	-35.04	8.17	9.34	-36.21	-13.00	-23.21	V
2122.37	-35.18	9.53	10.42	-36.07	-13.00	-23.07	V
2829.87	-32.86	11.27	11.12	<b>-32.71</b>	-13.00	-19.71	V
<b>LTE Band 12 / 1.4MHz / QPSK / RB Size 1 Offset 0/ The Worst Test Results for Highest</b>							
Frequency(MHz)	S G.Lev (dBm)	Ant(dBi)	Loss	PMea	Limit	Margin	Polarity
				(dBm)	( dBm )	(dBm)	
1430.29	-34.19	8.17	9.34	-35.36	-13.00	-22.36	H
2145.41	-34.85	9.53	10.42	-35.74	-13.00	-22.74	H
2860.82	-32.26	11.27	11.12	-32.11	-13.00	-19.11	H
1430.29	-35.79	8.17	9.34	-36.96	-13.00	-23.96	V
2145.41	-34.92	9.53	10.42	-35.81	-13.00	-22.81	V
2860.82	-32.12	11.27	11.12	<b>-31.97</b>	-13.00	-18.97	V

Remark: Spurious emissions within 30-1000MHz were found more than 20dB below limit line.

Test is divided into three directions, X/Y/Z. X pattern for the worst.



LTE BAND 12

LTE Band 12 / 3MHz / QPSK / RB Size 1 Offset 0/ The Worst Test Results for Lowest							
Frequency(MHz)	S G.Lev (dBm)	Ant(dBi)	Loss	PMea	Limit	Margin	Polarity
				(dBm)	(dBm)	(dBm)	
1400.84	-34.43	8.17	9.34	-35.60	-13.00	-22.60	H
2101.19	-34.53	9.53	10.42	-35.42	-13.00	-22.42	H
2801.70	-32.58	11.27	11.12	-32.43	-13.00	-19.43	H
1400.84	-35.51	8.17	9.34	-36.68	-13.00	-23.68	V
2101.19	-34.70	9.53	10.42	-35.59	-13.00	-22.59	V
2801.70	-32.36	11.27	11.12	<b>-32.21</b>	-13.00	-19.21	V
LTE Band 12 / 3MHz / QPSK / RB Size 1 Offset 0/ The Worst Test Results for Middle							
Frequency(MHz)	S G.Lev (dBm)	Ant(dBi)	Loss	PMea	Limit	Margin	Polarity
				(dBm)	(dBm)	(dBm)	
1414.65	-34.88	8.17	9.34	-36.05	-13.00	-23.05	H
2122.09	-34.18	9.53	10.42	-35.07	-13.00	-22.07	H
2829.62	-32.46	11.27	11.12	-32.31	-13.00	-19.31	H
1414.65	-34.89	8.17	9.34	-36.06	-13.00	-23.06	V
2122.09	-35.25	9.53	10.42	-36.14	-13.00	-23.14	V
2829.62	-32.34	11.27	11.12	<b>-32.19</b>	-13.00	-19.19	V
LTE Band 12 / 3MHz / QPSK / RB Size 1 Offset 0/ The Worst Test Results for Highest							
Frequency(MHz)	S G.Lev (dBm)	Ant(dBi)	Loss	PMea	Limit	Margin	Polarity
				(dBm)	(dBm)	(dBm)	
1428.50	-34.06	8.17	9.34	-35.23	-13.00	-22.23	H
2143.49	-35.36	9.53	10.42	-36.25	-13.00	-23.25	H
2857.79	-33.16	11.27	11.12	-33.01	-13.00	-20.01	H
1428.50	-35.88	8.17	9.34	-37.05	-13.00	-24.05	V
2143.49	-34.56	9.53	10.42	-35.45	-13.00	-22.45	V
2857.79	-31.81	11.27	11.12	<b>-31.66</b>	-13.00	-18.66	V

Remark: Spurious emissions within 30-1000MHz were found more than 20dB below limit line.

Test is divided into three directions, X/Y/Z. X pattern for the worst.



LTE BAND 12

LTE Band 12 / 5MHz / QPSK / RB Size 1 Offset 0/ The Worst Test Results for Lowest							
Frequency(MHz)	S G.Lev (dBm)	Ant(dBi)	Loss	PMea	Limit	Margin	Polarity
				(dBm)	(dBm)	(dBm)	
1402.98	-33.95	8.17	9.34	-35.12	-13.00	-22.12	H
2104.24	-35.47	9.53	10.42	-36.36	-13.00	-23.36	H
2805.94	-32.60	11.27	11.12	-32.45	-13.00	-19.45	H
1402.98	-35.06	8.17	9.34	-36.23	-13.00	-23.23	V
2104.24	-33.98	9.53	10.42	-34.87	-13.00	-21.87	V
2805.94	-32.15	11.27	11.12	<b>-32.00</b>	-13.00	-19.00	V
LTE Band 12 / 5MHz / QPSK / RB Size 1 Offset 0/ The Worst Test Results for Middle							
Frequency(MHz)	S G.Lev (dBm)	Ant(dBi)	Loss	PMea	Limit	Margin	Polarity
				(dBm)	(dBm)	(dBm)	
1414.87	-34.17	8.17	9.34	-35.34	-13.00	-22.34	H
2122.03	-34.35	9.53	10.42	-35.24	-13.00	-22.24	H
2829.55	-32.46	11.27	11.12	<b>-32.31</b>	-13.00	-19.31	H
1414.87	-34.96	8.17	9.34	-36.13	-13.00	-23.13	V
2122.03	-33.78	9.53	10.42	-34.67	-13.00	-21.67	V
2829.55	-32.66	11.27	11.12	-32.51	-13.00	-19.51	V
LTE Band 12 / 5MHz / QPSK / RB Size 1 Offset 0/ The Worst Test Results for Highest							
Frequency(MHz)	S G.Lev (dBm)	Ant(dBi)	Loss	PMea	Limit	Margin	Polarity
				(dBm)	(dBm)	(dBm)	
1426.91	-34.73	8.17	9.34	-35.90	-13.00	-22.90	H
2140.21	-34.33	9.53	10.42	-35.22	-13.00	-22.22	H
2853.90	-32.69	11.27	11.12	<b>-32.54</b>	-13.00	-19.54	H
1426.91	-35.28	8.17	9.34	-36.45	-13.00	-23.45	V
2140.21	-34.00	9.53	10.42	-34.89	-13.00	-21.89	V
2853.90	-33.13	11.27	11.12	-32.98	-13.00	-19.98	V

Remark: Spurious emissions within 30-1000MHz were found more than 20dB below limit line.

Test is divided into three directions, X/Y/Z. X pattern for the worst.



**LTE BAND 12**

LTE Band 12 / 10MHz / QPSK / RB Size 1 Offset 0/ The Worst Test Results for Lowest							
Frequency(MHz)	S G.Lev (dBm)	Ant(dBi)	Loss	PMea	Limit	Margin	Polarity
				(dBm)	( dBm )	(dBm)	
1407.76	-34.41	8.17	9.34	-35.58	-13.00	-22.58	H
2111.70	-34.99	9.53	10.42	-35.88	-13.00	-22.88	H
2815.96	-32.70	11.27	11.12	-32.55	-13.00	-19.55	H
1407.76	-35.91	8.17	9.34	-37.08	-13.00	-24.08	V
2111.70	-34.68	9.53	10.42	-35.57	-13.00	-22.57	V
2815.96	-32.48	11.27	11.12	<b>-32.33</b>	-13.00	-19.33	V
LTE Band 12 / 10MHz / QPSK / RB Size 1 Offset 0/ The Worst Test Results for Middle							
Frequency(MHz)	S G.Lev (dBm)	Ant(dBi)	Loss	PMea	Limit	Margin	Polarity
				(dBm)	( dBm )	(dBm)	
1414.51	-33.99	8.17	9.34	-35.16	-13.00	-22.16	H
2122.13	-34.58	9.53	10.42	-35.47	-13.00	-22.47	H
2829.80	-32.63	11.27	11.12	-32.48	-13.00	-19.48	H
1414.51	-34.79	8.17	9.34	-35.96	-13.00	-22.96	V
2122.13	-34.34	9.53	10.42	-35.23	-13.00	-22.23	V
2829.80	-32.50	11.27	11.12	<b>-32.35</b>	-13.00	-19.35	V
LTE Band 12 / 10MHz / QPSK / RB Size 1 Offset 0/ The Worst Test Results for Highest							
Frequency(MHz)	S G.Lev (dBm)	Ant(dBi)	Loss	PMea	Limit	Margin	Polarity
				(dBm)	( dBm )	(dBm)	
1421.80	-34.64	8.17	9.34	-35.81	-13.00	-22.81	H
2132.59	-34.66	9.53	10.42	-35.55	-13.00	-22.55	H
2843.62	-32.26	11.27	11.12	<b>-32.11</b>	-13.00	-19.11	H
1421.80	-35.80	8.17	9.34	-36.97	-13.00	-23.97	V
2132.59	-34.78	9.53	10.42	-35.67	-13.00	-22.67	V
2843.62	-33.15	11.27	11.12	-33.00	-13.00	-20.00	V

Remark: Spurious emissions within 30-1000MHz were found more than 20dB below limit line.

Test is divided into three directions, X/Y/Z. X pattern for the worst.



**LTE BAND 13**

LTE Band 13 / 5MHz / QPSK / RB Size 1 Offset 0/ The Worst Test Results for Lowest							
Frequency(MHz)	S G.Lev (dBm)	Ant(dBi)	Loss	PMea	Limit	Margin	Polarity
				(dBm)	( dBm )	(dBm)	
1559.16	-34.73	8.17	9.34	-35.90	-13.00	-22.90	H
2338.15	-35.02	9.53	10.42	-35.91	-13.00	-22.91	H
3117.93	-33.18	11.27	11.12	-33.03	-13.00	-20.03	H
1559.16	-34.85	8.17	9.34	-36.02	-13.00	-23.02	V
2338.15	-34.48	9.53	10.42	-35.37	-13.00	-22.37	V
3117.93	-31.95	11.27	11.12	<b>-31.80</b>	-13.00	-18.80	V
LTE Band 13 / 5MHz / QPSK / RB Size 1 Offset 0/ The Worst Test Results for Middle							
Frequency(MHz)	S G.Lev (dBm)	Ant(dBi)	Loss	PMea	Limit	Margin	Polarity
				(dBm)	( dBm )	(dBm)	
1564.02	-34.26	8.17	9.34	-35.43	-13.00	-22.43	H
2346.04	-34.91	9.53	10.42	-35.80	-13.00	-22.80	H
3128.01	-32.68	11.27	11.12	-32.53	-13.00	-19.53	H
1564.02	-34.99	8.17	9.34	-36.16	-13.00	-23.16	V
2346.04	-34.00	9.53	10.42	-34.89	-13.00	-21.89	V
3128.01	-31.97	11.27	11.12	<b>-31.82</b>	-13.00	-18.82	V
LTE Band 13 / 5MHz / QPSK / RB Size 1 Offset 0/ The Worst Test Results for Highest							
Frequency(MHz)	S G.Lev (dBm)	Ant(dBi)	Loss	PMea	Limit	Margin	Polarity
				(dBm)	( dBm )	(dBm)	
1568.98	-34.03	8.17	9.34	-35.20	-13.00	-22.20	H
2353.19	-35.47	9.53	10.42	-36.36	-13.00	-23.36	H
3138.38	-33.64	11.27	11.12	-33.49	-13.00	-20.49	H
1568.98	-36.01	8.17	9.34	-37.18	-13.00	-24.18	V
2353.19	-35.03	9.53	10.42	-35.92	-13.00	-22.92	V
3138.38	-33.14	11.27	11.12	<b>-32.99</b>	-13.00	-19.99	V

Remark: Spurious emissions within 30-1000MHz were found more than 20dB below limit line.

Test is divided into three directions, X/Y/Z. X pattern for the worst.



## LTE BAND 13

LTE Band 13 / 10MHz / QPSK / RB Size 1 Offset 0/ The Worst Test Results for Middle							
Frequency(MHz)	S G.Lev (dBm)	Ant(dBi)	Loss	PMea	Limit	Margin	Polarity
				(dBm)	(dBm)	(dBm)	
1564.07	-33.83	8.17	9.34	-35.00	-13.00	-22.00	H
2346.13	-34.17	9.53	10.42	-35.06	-13.00	-22.06	H
3128.10	-32.87	11.27	11.12	-32.72	-13.00	-19.72	H
1564.07	-35.32	8.17	9.34	-36.49	-13.00	-23.49	V
2346.13	-34.27	9.53	10.42	-35.16	-13.00	-22.16	V
3128.10	-32.35	11.27	11.12	<b>-32.20</b>	-13.00	-19.20	V

Remark: Spurious emissions within 30-1000MHz were found more than 20dB below limit line.

Test is divided into three directions, X/Y/Z. X pattern for the worst.







**LTE BAND 17**

LTE Band 17 / 5MHz / QPSK / RB Size 1 Offset 0/ The Worst Test Results for Lowest							
Frequency(MHz)	S G.Lev (dBm)	Ant(dBi)	Loss	PMea	Limit	Margin	Polarity
				(dBm)	(dBm)	(dBm)	
1413.40	-34.31	12.66	12.54	-34.19	-25.00	-9.19	H
2119.38	-35.37	11.46	12.57	-36.48	-25.00	-11.48	H
2826.72	-33.25	12.79	21.23	-41.69	-25.00	-16.69	H
1413.40	-35.50	12.66	12.54	-35.38	-25.00	-10.38	V
2119.38	-35.07	11.46	12.57	-36.18	-25.00	-11.18	V
2826.72	-32.93	12.79	21.23	-41.37	-25.00	-16.37	V
LTE Band 17 / 5MHz / QPSK / RB Size 1 Offset 0/ The Worst Test Results for Middle							
Frequency(MHz)	S G.Lev (dBm)	Ant(dBi)	Loss	PMea	Limit	Margin	Polarity
				(dBm)	(dBm)	(dBm)	
1420.18	-33.82	12.72	12.55	-33.65	-25.00	-8.65	H
2129.87	-34.63	11.46	12.57	-35.74	-25.00	-10.74	H
2839.82	-33.46	12.09	21.25	-42.62	-25.00	-17.62	H
1420.18	-35.23	12.80	12.55	-34.98	-25.00	-9.98	V
2129.87	-34.50	13.10	12.57	-33.97	-25.00	-8.97	V
2839.82	-32.78	12.33	21.25	-41.70	-25.00	-16.70	V
LTE Band 17 / 5MHz / QPSK / RB Size 1 Offset 0/ The Worst Test Results for Highest							
Frequency(MHz)	S G.Lev (dBm)	Ant(dBi)	Loss	PMea	Limit	Margin	Polarity
				(dBm)	(dBm)	(dBm)	
1427.28	-33.87	12.76	12.57	-33.68	-25.00	-8.68	H
2140.43	-35.20	11.45	12.58	-36.33	-25.00	-11.33	H
2854.63	-32.26	12.28	21.27	-41.25	-25.00	-16.25	H
1427.28	-35.03	12.76	12.57	-34.84	-25.00	-9.84	V
2140.43	-35.15	11.45	12.58	-36.28	-25.00	-11.28	V
2854.63	-32.08	12.28	21.27	-41.07	-25.00	-16.07	V

Remark: Spurious emissions within 30-1000MHz were found more than 20dB below limit line.

Test is divided into three directions, X/Y/Z. X pattern for the worst.



**LTE BAND 17**

<b>LTE Band 17 / 10MHz / QPSK / RB Size 1 Offset 0/ The Worst Test Results for Lowest</b>							
Frequency(MHz)	S G.Lev (dBm)	Ant(dBi)	Loss	PMea	Limit	Margin	Polarity
				(dBm)	(dBm)	(dBm)	
1418.37	-34.10	12.66	12.54	-33.98	-25.00	-8.98	H
2127.85	-35.31	11.46	12.57	-36.42	-25.00	-11.42	H
2836.22	-32.51	12.79	21.23	-40.95	-25.00	-15.95	H
1418.37	-35.78	12.66	12.54	-35.66	-25.00	-10.66	V
2127.85	-34.63	11.46	12.57	-35.74	-25.00	-10.74	V
2836.22	-32.01	12.79	21.23	-40.45	-25.00	-15.45	V
<b>LTE Band 17 / 10MHz / QPSK / RB Size 1 Offset 0/ The Worst Test Results for Middle</b>							
Frequency(MHz)	S G.Lev (dBm)	Ant(dBi)	Loss	PMea	Limit	Margin	Polarity
				(dBm)	(dBm)	(dBm)	
1419.89	-34.43	12.72	12.55	-34.26	-25.00	-9.26	H
2129.94	-34.72	11.46	12.57	-35.83	-25.00	-10.83	H
2839.83	-33.57	12.09	21.25	-42.73	-25.00	-17.73	H
1419.89	-34.77	12.80	12.55	-34.52	-25.00	-9.52	V
2129.94	-34.63	13.10	12.57	-34.10	-25.00	-9.10	V
2839.83	-33.19	12.33	21.25	-42.11	-25.00	-17.11	V
<b>LTE Band 17 / 10MHz / QPSK / RB Size 1 Offset 0/ The Worst Test Results for Highest</b>							
Frequency(MHz)	S G.Lev (dBm)	Ant(dBi)	Loss	PMea	Limit	Margin	Polarity
				(dBm)	(dBm)	(dBm)	
1422.35	-33.50	12.76	12.57	-33.31	-25.00	-8.31	H
2133.20	-35.14	11.45	12.58	-36.27	-25.00	-11.27	H
2844.02	-33.15	12.28	21.27	-42.14	-25.00	-17.14	H
1422.35	-35.39	12.76	12.57	-35.20	-25.00	-10.20	V
2133.20	-34.24	11.45	12.58	-35.37	-25.00	-10.37	V
2844.02	-31.73	12.28	21.27	-40.72	-25.00	-15.72	V

Remark: Spurious emissions within 30-1000MHz were found more than 20dB below limit line.

Test is divided into three directions, X/Y/Z. X pattern for the worst.



**LTE BAND 25**

<b>LTE Band 25 / 1.4MHz / QPSK / RB Size 1 Offset 0/ The Worst Test Results for Lowest</b>							
Frequency(MHz)	S G.Lev (dBm)	Ant(dBi)	Loss	PMea	Limit	Margin	Polarity
				(dBm)	(dBm)	(dBm)	
3701.31	-34.84	12.60	12.93	-35.17	-13.00	-22.17	H
5552.16	-34.01	13.10	17.11	-38.02	-13.00	-25.02	H
7402.60	-32.64	11.50	22.20	-43.34	-13.00	-30.34	H
3701.31	-34.60	12.60	12.93	<b>-34.93</b>	-13.00	-21.93	V
5552.16	-34.14	13.10	17.11	-38.15	-13.00	-25.15	V
7402.60	-32.10	11.50	22.20	-42.80	-13.00	-29.80	V
<b>LTE Band 25 / 1.4MHz / QPSK / RB Size 1 Offset 0/ The Worst Test Results for Middle</b>							
Frequency(MHz)	S G.Lev (dBm)	Ant(dBi)	Loss	PMea	Limit	Margin	Polarity
				(dBm)	(dBm)	(dBm)	
3764.94	-33.86	12.60	12.93	<b>-34.19</b>	-13.00	-21.19	H
5646.80	-34.87	13.10	17.11	-38.88	-13.00	-25.88	H
7530.06	-32.39	11.50	22.20	-43.09	-13.00	-30.09	H
3764.94	-34.66	12.60	12.93	-34.99	-13.00	-21.99	V
5646.80	-34.47	13.10	17.11	-38.48	-13.00	-25.48	V
7530.06	-33.09	11.50	22.20	-43.79	-13.00	-30.79	V
<b>LTE Band 25 / 1.4MHz / QPSK / RB Size 1 Offset 0/ The Worst Test Results for Highest</b>							
Frequency(MHz)	S G.Lev (dBm)	Ant(dBi)	Loss	PMea	Limit	Margin	Polarity
				(dBm)	(dBm)	(dBm)	
3828.38	-34.65	12.60	12.93	<b>-34.98</b>	-13.00	-21.98	H
5727.74	-35.04	13.10	17.11	-39.05	-13.00	-26.05	H
7657.04	-32.32	11.50	22.20	-43.02	-13.00	-30.02	H
3828.38	-35.13	12.60	12.93	-35.46	-13.00	-22.46	V
5727.74	-35.03	13.10	17.11	-39.04	-13.00	-26.04	V
7657.04	-32.11	11.50	22.20	-42.81	-13.00	-29.81	V

Remark: Spurious emissions within 30-1000MHz were found more than 20dB below limit line.

Test is divided into three directions, X/Y/Z. X pattern for the worst.



**LTE BAND 25**

LTE Band 25 / 3MHz / QPSK / RB Size 1 Offset 0/ The Worst Test Results for Lowest							
Frequency(MHz)	S G.Lev (dBm)	Ant(dBi)	Loss	PMea	Limit	Margin	Polarity
				(dBm)	(dBm)	(dBm)	
3703.15	-34.43	12.60	12.93	-34.76	-13.00	-21.76	H
5554.52	-35.41	13.10	17.11	-39.42	-13.00	-26.42	H
7406.02	-32.64	11.50	22.20	-43.34	-13.00	-30.34	H
3703.15	-34.77	12.60	12.93	-35.10	-13.00	-22.10	V
5554.52	-34.50	13.10	17.11	-38.51	-13.00	-25.51	V
7406.02	-32.27	11.50	22.20	-42.97	-13.00	-29.97	V
LTE Band 25 / 3MHz / QPSK / RB Size 1 Offset 0/ The Worst Test Results for Middle							
Frequency(MHz)	S G.Lev (dBm)	Ant(dBi)	Loss	PMea	Limit	Margin	Polarity
				(dBm)	(dBm)	(dBm)	
3764.90	-33.85	12.60	12.93	-34.18	-13.00	-21.18	H
5647.27	-34.42	13.10	17.11	-38.43	-13.00	-25.43	H
7530.12	-33.39	11.50	22.20	-44.09	-13.00	-31.09	H
3764.90	-34.96	12.60	12.93	-35.29	-13.00	-22.29	V
5647.27	-34.96	13.10	17.11	-38.97	-13.00	-25.97	V
7530.12	-33.06	11.50	22.20	-43.76	-13.00	-30.76	V
LTE Band 25 / 3MHz / QPSK / RB Size 1 Offset 0/ The Worst Test Results for Highest							
Frequency(MHz)	S G.Lev (dBm)	Ant(dBi)	Loss	PMea	Limit	Margin	Polarity
				(dBm)	(dBm)	(dBm)	
3827.21	-34.93	12.60	12.93	-35.26	-13.00	-22.26	H
5740.07	-34.12	13.10	17.11	-38.13	-13.00	-25.13	H
7654.23	-32.18	11.50	22.20	-42.88	-13.00	-29.88	H
3827.21	-34.61	12.60	12.93	-34.94	-13.00	-21.94	V
5740.07	-34.49	13.10	17.11	-38.50	-13.00	-25.50	V
7654.23	-32.57	11.50	22.20	-43.27	-13.00	-30.27	V

Remark: Spurious emissions within 30-1000MHz were found more than 20dB below limit line.

Test is divided into three directions, X/Y/Z. X pattern for the worst.



**LTE BAND 25**

LTE Band 25 / 5MHz / QPSK / RB Size 1 Offset 0/ The Worst Test Results for Lowest							
Frequency(MHz)	S G.Lev (dBm)	Ant(dBi)	Loss	PMea	Limit	Margin	Polarity
				(dBm)	(dBm)	(dBm)	
3705.12	-33.92	12.60	12.93	-34.25	-13.00	-21.25	H
5557.21	-34.31	13.10	17.11	-38.32	-13.00	-25.32	H
7410.24	-33.61	11.50	22.20	-44.31	-13.00	-31.31	H
3705.12	-34.94	12.60	12.93	-35.27	-13.00	-22.27	V
5557.21	-34.75	13.10	17.11	-38.76	-13.00	-25.76	V
7410.24	-33.12	11.50	22.20	-43.82	-13.00	-30.82	V
LTE Band 25 / 5MHz / QPSK / RB Size 1 Offset 0/ The Worst Test Results for Middle							
Frequency(MHz)	S G.Lev (dBm)	Ant(dBi)	Loss	PMea	Limit	Margin	Polarity
				(dBm)	(dBm)	(dBm)	
3765.24	-34.73	12.60	12.93	-35.06	-13.00	-22.06	H
5647.10	-34.72	13.10	17.11	-38.73	-13.00	-25.73	H
7530.19	-33.20	11.50	22.20	-43.90	-13.00	-30.90	H
3765.24	-35.72	12.60	12.93	-36.05	-13.00	-23.05	V
5647.10	-34.77	13.10	17.11	-38.78	-13.00	-25.78	V
7530.19	-32.65	11.50	22.20	-43.35	-13.00	-30.35	V
LTE Band 25 / 5MHz / QPSK / RB Size 1 Offset 0/ The Worst Test Results for Highest							
Frequency(MHz)	S G.Lev (dBm)	Ant(dBi)	Loss	PMea	Limit	Margin	Polarity
				(dBm)	(dBm)	(dBm)	
3825.29	-34.17	12.60	12.93	-34.50	-13.00	-21.50	H
5737.46	-34.90	13.10	17.11	-38.91	-13.00	-25.91	H
7650.62	-32.98	11.50	22.20	-43.68	-13.00	-30.68	H
3825.29	-35.45	12.60	12.93	-35.78	-13.00	-22.78	V
5737.46	-35.13	13.10	17.11	-39.14	-13.00	-26.14	V
7650.62	-31.75	11.50	22.20	-42.45	-13.00	-29.45	V

Remark: Spurious emissions within 30-1000MHz were found more than 20dB below limit line.

Test is divided into three directions, X/Y/Z. X pattern for the worst.



**LTE BAND 25**

LTE Band 25 / 10MHz / QPSK / RB Size 1 Offset 0/ The Worst Test Results for Lowest							
Frequency(MHz)	S G.Lev (dBm)	Ant(dBi)	Loss	PMea	Limit	Margin	Polarity
				(dBm)	(dBm)	(dBm)	
3710.10	-33.75	12.60	12.93	-34.08	-13.00	-21.08	H
5565.23	-35.15	13.10	17.11	-39.16	-13.00	-26.16	H
7419.77	-33.39	11.50	22.20	-44.09	-13.00	-31.09	H
3710.10	-35.08	12.60	12.93	-35.41	-13.00	-22.41	V
5565.23	-35.05	13.10	17.11	-39.06	-13.00	-26.06	V
7419.77	-32.74	11.50	22.20	-43.44	-13.00	-30.44	V
LTE Band 25 / 10MHz / QPSK / RB Size 1 Offset 0/ The Worst Test Results for Middle							
Frequency(MHz)	S G.Lev (dBm)	Ant(dBi)	Loss	PMea	Limit	Margin	Polarity
				(dBm)	(dBm)	(dBm)	
3765.13	-34.27	12.60	12.93	-34.60	-13.00	-21.60	H
5647.59	-34.93	13.10	17.11	-38.94	-13.00	-25.94	H
7530.03	-32.73	11.50	22.20	-43.43	-13.00	-30.43	H
3765.13	-35.28	12.60	12.93	-35.61	-13.00	-22.61	V
5647.59	-35.03	13.10	17.11	-39.04	-13.00	-26.04	V
7530.03	-32.64	11.50	22.20	-43.34	-13.00	-30.34	V
LTE Band 25 / 10MHz / QPSK / RB Size 1 Offset 0/ The Worst Test Results for Highest							
Frequency(MHz)	S G.Lev (dBm)	Ant(dBi)	Loss	PMea	Limit	Margin	Polarity
				(dBm)	(dBm)	(dBm)	
3820.15	-34.75	12.60	12.93	-35.08	-13.00	-22.08	H
5729.76	-34.60	13.10	17.11	-38.61	-13.00	-25.61	H
7640.24	-32.77	11.50	22.20	-43.47	-13.00	-30.47	H
3820.15	-35.65	12.60	12.93	-35.98	-13.00	-22.98	V
5729.76	-34.26	13.10	17.11	-38.27	-13.00	-25.27	V
7640.24	-32.16	11.50	22.20	-42.86	-13.00	-29.86	V

Remark: Spurious emissions within 30-1000MHz were found more than 20dB below limit line.

Test is divided into three directions, X/Y/Z. X pattern for the worst.



**LTE BAND 25**

LTE Band 25 / 15MHz / QPSK / RB Size 1 Offset 0/ The Worst Test Results for Lowest							
Frequency(MHz)	S G.Lev (dBm)	Ant(dBi)	Loss	PMea	Limit	Margin	Polarity
				(dBm)	(dBm)	(dBm)	
3715.11	-33.96	12.60	12.93	-34.29	-13.00	-21.29	H
5572.24	-34.88	13.10	17.11	-38.89	-13.00	-25.89	H
7430.51	-32.65	11.50	22.20	-43.35	-13.00	-30.35	H
3715.11	-34.75	12.60	12.93	-35.08	-13.00	-22.08	V
5572.24	-33.75	13.10	17.11	-37.76	-13.00	-24.76	V
7430.51	-32.02	11.50	22.20	-42.72	-13.00	-29.72	V
LTE Band 25 / 15MHz / QPSK / RB Size 1 Offset 0/ The Worst Test Results for Middle							
Frequency(MHz)	S G.Lev (dBm)	Ant(dBi)	Loss	PMea	Limit	Margin	Polarity
				(dBm)	(dBm)	(dBm)	
3764.96	-34.84	12.60	12.93	-35.17	-13.00	-22.17	H
5647.40	-34.10	13.10	17.11	-38.11	-13.00	-25.11	H
7430.02	-32.65	11.50	22.20	-43.35	-13.00	-30.35	H
3764.96	-35.60	12.60	12.93	-35.93	-13.00	-22.93	V
5647.40	-34.82	13.10	17.11	-38.83	-13.00	-25.83	V
7430.02	-31.95	11.50	22.20	-42.65	-13.00	-29.65	V
LTE Band 25 / 15MHz / QPSK / RB Size 1 Offset 0/ The Worst Test Results for Highest							
Frequency(MHz)	S G.Lev (dBm)	Ant(dBi)	Loss	PMea	Limit	Margin	Polarity
				(dBm)	(dBm)	(dBm)	
3815.69	-34.39	12.60	12.93	-34.72	-13.00	-21.72	H
5722.24	-34.60	13.10	17.11	-38.61	-13.00	-25.61	H
7630.47	-33.23	11.50	22.20	-43.93	-13.00	-30.93	H
3815.69	-35.50	12.60	12.93	-35.83	-13.00	-22.83	V
5722.24	-35.08	13.10	17.11	-39.09	-13.00	-26.09	V
7630.47	-31.86	11.50	22.20	-42.56	-13.00	-29.56	V

Remark: Spurious emissions within 30-1000MHz were found more than 20dB below limit line.

Test is divided into three directions, X/Y/Z. X pattern for the worst.



**LTE BAND 25**

LTE Band 25 / 20MHz / QPSK / RB Size 1 Offset 0/ The Worst Test Results for Lowest							
Frequency(MHz)	S G.Lev (dBm)	Ant(dBi)	Loss	PMea	Limit	Margin	Polarity
				(dBm)	(dBm)	(dBm)	
3720.24	-33.56	12.60	12.93	-33.89	-13.00	-20.89	H
5580.20	-34.82	13.10	17.11	-38.83	-13.00	-25.83	H
7439.87	-32.26	11.50	22.20	-42.96	-13.00	-29.96	H
3720.24	-35.64	12.60	12.93	-35.97	-13.00	-22.97	V
5580.20	-34.64	13.10	17.11	-38.65	-13.00	-25.65	V
7439.87	-32.67	11.50	22.20	-43.37	-13.00	-30.37	V
LTE Band 25 / 20MHz / QPSK / RB Size 1 Offset 0/ The Worst Test Results for Middle							
Frequency(MHz)	S G.Lev (dBm)	Ant(dBi)	Loss	PMea	Limit	Margin	Polarity
				(dBm)	(dBm)	(dBm)	
3765.03	-34.73	12.60	12.93	-35.06	-13.00	-22.06	H
5646.90	-34.33	13.10	17.11	-38.34	-13.00	-25.34	H
7530.15	-33.33	11.50	22.20	-44.03	-13.00	-31.03	H
3765.03	-35.26	12.60	12.93	-35.59	-13.00	-22.59	V
5646.90	-34.46	13.10	17.11	-38.47	-13.00	-25.47	V
7530.15	-31.88	11.50	22.20	-42.58	-13.00	-29.58	V
LTE Band 25 / 20MHz / QPSK / RB Size 1 Offset 0/ The Worst Test Results for Highest							
Frequency(MHz)	S G.Lev (dBm)	Ant(dBi)	Loss	PMea	Limit	Margin	Polarity
				(dBm)	(dBm)	(dBm)	
3810.47	-34.26	12.60	12.93	-34.59	-13.00	-21.59	H
5715.47	-34.81	13.10	17.11	-38.82	-13.00	-25.82	H
7619.92	-33.28	11.50	22.20	-43.98	-13.00	-30.98	H
3810.47	-35.77	12.60	12.93	-36.10	-13.00	-23.10	V
5715.47	-34.52	13.10	17.11	-38.53	-13.00	-25.53	V
7619.92	-32.65	11.50	22.20	-43.35	-13.00	-30.35	V

Remark: Spurious emissions within 30-1000MHz were found more than 20dB below limit line.

Test is divided into three directions, X/Y/Z. X pattern for the worst.





**LTE BAND 26**

<b>LTE Band 26 / 1.4MHz / QPSK / RB Size 1 Offset 0/ The Worst Test Results for Lowest</b>							
Frequency(MHz)	S G.Lev (dBm)	Ant(dBi)	Loss	PMea	Limit	Margin	Polarity
				(dBm)	(dBm)	(dBm)	
1629.04	-33.84	12.90	12.56	-33.50	-13.00	-20.50	H
2444.42	-35.35	13.10	12.46	-34.71	-13.00	-21.71	H
3258.55	-32.82	12.33	21.13	-41.62	-13.00	-28.62	H
1629.04	-34.76	12.90	12.76	-34.62	-13.00	-21.62	V
2444.42	-34.61	13.10	16.32	-37.83	-13.00	-24.83	V
3258.55	-32.01	12.33	21.13	-40.81	-13.00	-27.81	V
<b>LTE Band 26 / 1.4MHz / QPSK / RB Size 1 Offset 0/ The Worst Test Results for Middle</b>							
Frequency(MHz)	S G.Lev (dBm)	Ant(dBi)	Loss	PMea	Limit	Margin	Polarity
				(dBm)	(dBm)	(dBm)	
1663.18	-33.91	12.80	12.56	-33.67	-13.00	-20.67	H
2494.15	-35.10	13.10	12.46	-34.46	-13.00	-21.46	H
3326.11	-33.30	12.33	21.13	-42.10	-13.00	-29.10	H
1663.18	-35.10	12.80	12.76	-35.06	-13.00	-22.06	V
2494.15	-34.15	13.10	16.32	-37.37	-13.00	-24.37	V
3326.11	-32.77	12.33	21.13	-41.57	-13.00	-28.57	V
<b>LTE Band 26 / 1.4MHz / QPSK / RB Size 1 Offset 0/ The Worst Test Results for Highest</b>							
Frequency(MHz)	S G.Lev (dBm)	Ant(dBi)	Loss	PMea	Limit	Margin	Polarity
				(dBm)	(dBm)	(dBm)	
1696.34	-33.92	12.61	12.56	-33.87	-13.00	-20.87	H
2544.88	-35.08	13.12	12.46	-34.42	-13.00	-21.42	H
3392.93	-33.45	12.32	21.13	-42.26	-13.00	-29.26	H
1696.34	-34.91	12.61	12.76	-35.06	-13.00	-22.06	V
2544.88	-33.75	13.12	16.32	-36.95	-13.00	-23.95	V
3392.93	-32.78	12.32	21.13	-41.59	-13.00	-28.59	V

Remark: Spurious emissions within 30-1000MHz were found more than 20dB below limit line.

Test is divided into three directions, X/Y/Z. X pattern for the worst.



**LTE BAND 26**

LTE Band 26 / 3MHz / QPSK / RB Size 1 Offset 0/ The Worst Test Results for Lowest							
Frequency(MHz)	S G.Lev (dBm)	Ant(dBi)	Loss	PMea	Limit	Margin	Polarity
				(dBm)	(dBm)	(dBm)	
1631.08	-33.88	12.90	12.56	-33.54	-13.00	-20.54	H
2446.26	-35.46	13.10	12.46	-34.82	-13.00	-21.82	H
3262.85	-32.91	12.33	21.13	-41.71	-13.00	-28.71	H
1631.08	-34.60	12.90	12.76	-34.46	-13.00	-21.46	V
2446.26	-33.97	13.10	16.32	-37.19	-13.00	-24.19	V
3262.85	-32.57	12.33	21.13	-41.37	-13.00	-28.37	V
LTE Band 26 / 3MHz / QPSK / RB Size 1 Offset 0/ The Worst Test Results for Middle							
Frequency(MHz)	S G.Lev (dBm)	Ant(dBi)	Loss	PMea	Limit	Margin	Polarity
				(dBm)	(dBm)	(dBm)	
1663.03	-34.04	12.80	12.56	-33.80	-13.00	-20.80	H
2494.22	-35.15	13.10	12.46	-34.51	-13.00	-21.51	H
3325.86	-33.15	12.33	21.13	-41.95	-13.00	-28.95	H
1663.03	-35.72	12.80	12.76	-35.68	-13.00	-22.68	V
2494.22	-34.30	13.10	16.32	-37.52	-13.00	-24.52	V
3325.86	-32.82	12.33	21.13	-41.62	-13.00	-28.62	V
LTE Band 26 / 3MHz / QPSK / RB Size 1 Offset 0/ The Worst Test Results for Highest							
Frequency(MHz)	S G.Lev (dBm)	Ant(dBi)	Loss	PMea	Limit	Margin	Polarity
				(dBm)	(dBm)	(dBm)	
1695.75	-33.52	12.61	12.56	-33.47	-13.00	-20.47	H
2542.49	-34.15	13.12	12.46	-33.49	-13.00	-20.49	H
3390.14	-32.33	12.32	21.13	-41.14	-13.00	-28.14	H
1695.75	-35.49	12.61	12.76	-35.64	-13.00	-22.64	V
2542.49	-34.35	13.12	16.32	-37.55	-13.00	-24.55	V
3390.14	-32.53	12.32	21.13	-41.34	-13.00	-28.34	V

Remark: Spurious emissions within 30-1000MHz were found more than 20dB below limit line.

Test is divided into three directions, X/Y/Z. X pattern for the worst.



**LTE BAND 26**

LTE Band 26 / 5MHz / QPSK / RB Size 1 Offset 0/ The Worst Test Results for Lowest							
Frequency(MHz)	S G.Lev (dBm)	Ant(dBi)	Loss	PMea	Limit	Margin	Polarity
				(dBm)	(dBm)	(dBm)	
1633.11	-33.62	12.90	12.56	-33.28	-13.00	-20.28	H
2499.27	-35.09	13.10	12.46	-34.45	-13.00	-21.45	H
3266.72	-32.20	12.33	21.13	-41.00	-13.00	-28.00	H
1633.11	-34.66	12.90	12.76	-34.52	-13.00	-21.52	V
2499.27	-34.43	13.10	16.32	-37.65	-13.00	-24.65	V
3266.72	-32.51	12.33	21.13	-41.31	-13.00	-28.31	V
LTE Band 26 / 5MHz / QPSK / RB Size 1 Offset 0/ The Worst Test Results for Middle							
Frequency(MHz)	S G.Lev (dBm)	Ant(dBi)	Loss	PMea	Limit	Margin	Polarity
				(dBm)	(dBm)	(dBm)	
1662.83	-33.51	12.80	12.56	-33.27	-13.00	-20.27	H
2493.96	-34.28	13.10	12.46	-33.64	-13.00	-20.64	H
3326.13	-33.38	12.33	21.13	-42.18	-13.00	-29.18	H
1662.83	-35.74	12.80	12.76	-35.70	-13.00	-22.70	V
2493.96	-34.37	13.10	16.32	-37.59	-13.00	-24.59	V
3326.13	-33.02	12.33	21.13	-41.82	-13.00	-28.82	V
LTE Band 26 / 5MHz / QPSK / RB Size 1 Offset 0/ The Worst Test Results for Highest							
Frequency(MHz)	S G.Lev (dBm)	Ant(dBi)	Loss	PMea	Limit	Margin	Polarity
				(dBm)	(dBm)	(dBm)	
1693.67	-33.95	12.61	12.56	-33.90	-13.00	-20.90	H
2539.20	-34.16	13.12	12.46	-33.50	-13.00	-20.50	H
3386.05	-33.65	12.32	21.13	-42.46	-13.00	-29.46	H
1693.67	-35.39	12.61	12.76	-35.54	-13.00	-22.54	V
2539.20	-34.00	13.12	16.32	-37.20	-13.00	-24.20	V
3386.05	-31.89	12.32	21.13	-40.70	-13.00	-27.70	V

Remark: Spurious emissions within 30-1000MHz were found more than 20dB below limit line.

Test is divided into three directions, X/Y/Z. X pattern for the worst.



**LTE BAND 26**

LTE Band 26 / 10MHz / QPSK / RB Size 1 Offset 0/ The Worst Test Results for Lowest							
Frequency(MHz)	S G.Lev (dBm)	Ant(dBi)	Loss	PMea	Limit	Margin	Polarity
				(dBm)	(dBm)	(dBm)	
1640.43	-33.87	12.90	12.56	-33.53	-13.00	-20.53	H
2460.21	-35.26	13.10	12.46	-34.62	-13.00	-21.62	H
3280.67	-33.38	12.33	21.13	-42.18	-13.00	-29.18	H
1640.43	-34.76	12.90	12.76	-34.62	-13.00	-21.62	V
2460.21	-34.33	13.10	16.32	-37.55	-13.00	-24.55	V
3280.67	-32.15	12.33	21.13	-40.95	-13.00	-27.95	V
LTE Band 26 / 10MHz / QPSK / RB Size 1 Offset 0/ The Worst Test Results for Middle							
Frequency(MHz)	S G.Lev (dBm)	Ant(dBi)	Loss	PMea	Limit	Margin	Polarity
				(dBm)	(dBm)	(dBm)	
1662.83	-34.49	12.80	12.56	-34.25	-13.00	-21.25	H
2494.29	-35.04	13.10	12.46	-34.40	-13.00	-21.40	H
3326.15	-33.07	12.33	21.13	-41.87	-13.00	-28.87	H
1662.83	-35.92	12.80	12.76	-35.88	-13.00	-22.88	V
2494.29	-34.85	13.10	16.32	-38.07	-13.00	-25.07	V
3326.15	-33.04	12.33	21.13	-41.84	-13.00	-28.84	V
LTE Band 26 / 10MHz / QPSK / RB Size 1 Offset 0/ The Worst Test Results for Highest							
Frequency(MHz)	S G.Lev (dBm)	Ant(dBi)	Loss	PMea	Limit	Margin	Polarity
				(dBm)	(dBm)	(dBm)	
1688.45	-34.19	12.61	12.56	-34.14	-13.00	-21.14	H
2532.30	-35.08	13.12	12.46	-34.42	-13.00	-21.42	H
3375.89	-33.60	12.32	21.13	-42.41	-13.00	-29.41	H
1688.45	-35.61	12.61	12.76	-35.76	-13.00	-22.76	V
2532.30	-35.02	13.12	16.32	-38.22	-13.00	-25.22	V
3375.89	-32.21	12.32	21.13	-41.02	-13.00	-28.02	V

Remark: Spurious emissions within 30-1000MHz were found more than 20dB below limit line.

Test is divided into three directions, X/Y/Z. X pattern for the worst.



**LTE BAND 26**

LTE Band 26 / 15MHz / QPSK / RB Size 1 Offset 0/ The Worst Test Results for Lowest							
Frequency(MHz)	S G.Lev (dBm)	Ant(dBi)	Loss	PMea	Limit	Margin	Polarity
				(dBm)	(dBm)	(dBm)	
1645.29	-34.08	12.90	12.56	-33.74	-13.00	-20.74	H
2467.63	-34.31	13.10	12.46	-33.67	-13.00	-20.67	H
3290.94	-33.57	12.33	21.13	-42.37	-13.00	-29.37	H
1645.29	-35.31	12.90	12.76	-35.17	-13.00	-22.17	V
2467.63	-33.95	13.10	16.32	-37.17	-13.00	-24.17	V
3290.94	-31.87	12.33	21.13	-40.67	-13.00	-27.67	V
LTE Band 26 / 5MHz / QPSK / RB Size 1 Offset 0/ The Worst Test Results for Middle							
Frequency(MHz)	S G.Lev (dBm)	Ant(dBi)	Loss	PMea	Limit	Margin	Polarity
				(dBm)	(dBm)	(dBm)	
1662.79	-33.54	12.80	12.56	-33.30	-13.00	-20.30	H
2493.97	-34.71	13.10	12.46	-34.07	-13.00	-21.07	H
3326.07	-33.54	12.33	21.13	-42.34	-13.00	-29.34	H
1662.79	-35.23	12.80	12.76	-35.19	-13.00	-22.19	V
2493.97	-34.01	13.10	16.32	-37.23	-13.00	-24.23	V
3326.07	-31.80	12.33	21.13	-40.60	-13.00	-27.60	V
LTE Band 26 / 5MHz / QPSK / RB Size 1 Offset 0/ The Worst Test Results for Highest							
Frequency(MHz)	S G.Lev (dBm)	Ant(dBi)	Loss	PMea	Limit	Margin	Polarity
				(dBm)	(dBm)	(dBm)	
1683.61	-34.89	12.61	12.56	-34.84	-13.00	-21.84	H
2524.35	-35.14	13.12	12.46	-34.48	-13.00	-21.48	H
3366.56	-33.07	12.32	21.13	-41.88	-13.00	-28.88	H
1683.61	-35.12	12.61	12.76	-35.27	-13.00	-22.27	V
2524.35	-35.14	13.12	16.32	-38.34	-13.00	-25.34	V
3366.56	-31.77	12.32	21.13	-40.58	-13.00	-27.58	V

Remark: Spurious emissions within 30-1000MHz were found more than 20dB below limit line.

Test is divided into three directions, X/Y/Z. X pattern for the worst.



**LTE BAND 41**

LTE Band41 / 5MHz / QPSK / RB Size 1 Offset 0/ The Worst Test Results for Lowest							
Frequency(MHz)	S G.Lev (dBm)	Ant(dBi)	Loss	PMea	Limit	Margin	Polarity
				(dBm)	(dBm)	(dB)	
5305.28	-34.74	12.66	12.54	-34.62	-25.00	-9.62	H
7957.55	-35.24	11.46	12.57	-36.35	-25.00	-11.35	H
10610.32	-33.26	12.79	21.23	-41.70	-25.00	-16.70	H
4996.85	-34.73	12.66	12.54	-34.61	-25.00	-9.61	V
7495.55	-35.06	11.46	12.57	-36.17	-25.00	-11.17	V
9994.13	-32.03	12.79	21.23	-40.47	-25.00	-15.47	V
LTE Band 41 / 5MHz / QPSK / RB Size 1 Offset 0/ The Worst Test Results for Middle							
Frequency(MHz)	S G.Lev (dBm)	Ant(dBi)	Loss	PMea	Limit	Margin	Polarity
				(dBm)	(dBm)	(dB)	
5186.47	-34.61	12.72	12.55	-34.44	-25.00	-9.44	H
7778.95	-34.28	11.46	12.57	-35.39	-25.00	-10.39	H
10372.17	-32.72	12.09	21.25	-41.88	-25.00	-16.88	H
5186.47	-34.62	12.80	12.55	-34.37	-25.00	-9.37	V
7778.95	-34.87	13.10	12.57	-34.34	-25.00	-9.34	V
10372.17	-32.70	12.33	21.25	-41.62	-25.00	-16.62	V
LTE Band41 / 5MHz / QPSK / RB Size 1 Offset 0/ The Worst Test Results for Highest							
Frequency(MHz)	S G.Lev (dBm)	Ant(dBi)	Loss	PMea	Limit	Margin	Polarity
				(dBm)	(dBm)	(dB)	
5115.02	-33.65	12.76	12.57	-33.46	-25.00	-8.46	H
7672.07	-35.39	11.45	12.58	-36.52	-25.00	-11.52	H
10230.07	-32.62	12.28	21.27	-41.61	-25.00	-16.61	H
5115.02	-35.98	12.76	12.57	-35.79	-25.00	-10.79	V
7672.07	-34.74	11.45	12.58	-35.87	-25.00	-10.87	V
10230.07	-32.40	12.28	21.27	-41.39	-25.00	-16.39	V

Remark: Spurious emissions within 30-1000MHz were found more than 20dB below limit line.

Test is divided into three directions, X/Y/Z. X pattern for the worst.



**LTE BAND 41**

LTE Band 41 / 10MHz / QPSK / RB Size 1 Offset 0/ The Worst Test Results for Lowest							
Frequency(MHz)	S G.Lev (dBm)	Ant(dBi)	Loss	PMea	Limit	Margin	Polarity
				(dBm)	(dBm)	(dB)	
5002.29	-34.75	12.66	12.54	-34.63	-25.00	-9.63	H
7503.36	-34.93	11.46	12.57	-36.04	-25.00	-11.04	H
10004.15	-32.30	12.79	21.23	-40.74	-25.00	-15.74	H
5002.29	-35.30	12.66	12.54	-35.18	-25.00	-10.18	V
7503.36	-35.09	11.46	12.57	-36.20	-25.00	-11.20	V
10004.15	-32.26	12.79	21.23	-40.70	-25.00	-15.70	V
LTE Band 41 / 10MHz / QPSK / RB Size 1 Offset 0/ The Worst Test Results for Middle							
Frequency(MHz)	S G.Lev (dBm)	Ant(dBi)	Loss	PMea	Limit	Margin	Polarity
				(dBm)	(dBm)	(dB)	
5186.66	-34.50	12.72	12.55	-34.33	-25.00	-9.33	H
7779.60	-34.78	11.46	12.57	-35.89	-25.00	-10.89	H
10371.34	-33.28	12.09	21.25	-42.44	-25.00	-17.44	H
5186.66	-35.40	12.80	12.55	-35.15	-25.00	-10.15	V
7779.60	-34.15	13.10	12.57	-33.62	-25.00	-8.62	V
10371.34	-33.05	12.33	21.25	-41.97	-25.00	-16.97	V
LTE Band 41 / 10MHz / QPSK / RB Size 1 Offset 0/ The Worst Test Results for Highest							
Frequency(MHz)	S G.Lev (dBm)	Ant(dBi)	Loss	PMea	Limit	Margin	Polarity
				(dBm)	(dBm)	(dB)	
5370.34	-33.88	12.76	12.57	-33.69	-25.00	-8.69	H
8055.87	-34.44	11.45	12.58	-35.57	-25.00	-10.57	H
10740.12	-33.24	12.28	21.27	-42.23	-25.00	-17.23	H
5370.34	-34.86	12.76	12.57	-34.67	-25.00	-9.67	V
8055.87	-35.07	11.45	12.58	-36.20	-25.00	-11.20	V
10740.12	-32.86	12.28	21.27	-41.85	-25.00	-16.85	V

Remark: Spurious emissions within 30-1000MHz were found more than 20dB below limit line.

Test is divided into three directions, X/Y/Z. X pattern for the worst.



**LTE BAND 41**

<b>LTE Band 41 / 15MHz / QPSK / RB Size 1 Offset 0/ The Worst Test Results for Lowest</b>							
Frequency(MHz)	S G.Lev (dBm)	Ant(dBi)	Loss	PMea	Limit	Margin	Polarity
				(dBm)	(dBm)	(dB)	
5124.79	-34.71	12.66	12.54	-34.59	-25.00	-9.59	H
7687.45	-34.68	11.46	12.57	-35.79	-25.00	-10.79	H
10250.68	-32.75	12.79	21.23	-41.19	-25.00	-16.19	H
5124.79	-34.84	12.66	12.54	-34.72	-25.00	-9.72	V
7687.45	-35.24	11.46	12.57	-36.35	-25.00	-11.35	V
10250.68	-31.96	12.79	21.23	-40.40	-25.00	-15.40	V
<b>LTE Band 41 / 15MHz / QPSK / RB Size 1 Offset 0/ The Worst Test Results for Middle</b>							
Frequency(MHz)	S G.Lev (dBm)	Ant(dBi)	Loss	PMea	Limit	Margin	Polarity
				(dBm)	(dBm)	(dB)	
5185.90	-33.47	12.72	12.55	-33.30	-25.00	-8.30	H
7779.07	-34.77	11.46	12.57	-35.88	-25.00	-10.88	H
10372.28	-32.59	12.09	21.25	-41.75	-25.00	-16.75	H
5185.90	-35.84	12.80	12.55	-35.59	-25.00	-10.59	V
7779.07	-33.98	13.10	12.57	-33.45	-25.00	-8.45	V
10372.28	-32.88	12.33	21.25	-41.80	-25.00	-16.80	V
<b>LTE Band 41 / 15MHz / QPSK / RB Size 1 Offset 0/ The Worst Test Results for Highest</b>							
Frequency(MHz)	S G.Lev (dBm)	Ant(dBi)	Loss	PMea	Limit	Margin	Polarity
				(dBm)	(dBm)	(dB)	
5295.73	-34.15	12.76	12.57	-33.96	-25.00	-8.96	H
7941.99	-34.49	11.45	12.58	-35.62	-25.00	-10.62	H
10590.13	-32.46	12.28	21.27	-41.45	-25.00	-16.45	H
5295.73	-35.54	12.76	12.57	-35.35	-25.00	-10.35	V
7941.99	-33.85	11.45	12.58	-34.98	-25.00	-9.98	V
10590.13	-33.06	12.28	21.27	-42.05	-25.00	-17.05	V

Remark: Spurious emissions within 30-1000MHz were found more than 20dB below limit line.

Test is divided into three directions, X/Y/Z. X pattern for the worst.





**LTE BAND 41**

LTE Band 41 / 20MHz / QPSK / RB Size 1 Offset 0/ The Worst Test Results for Lowest							
Frequency(MHz)	S G.Lev (dBm)	Ant(dBi)	Loss	PMea	Limit	Margin	Polarity
				(dBm)	(dBm)	(dB)	
5129.93	-33.98	12.66	12.54	-33.86	-25.00	-8.86	H
7695.22	-34.99	11.46	12.57	-36.10	-25.00	-11.10	H
10260.24	-33.04	12.79	21.23	-41.48	-25.00	-16.48	H
5129.93	-35.85	12.66	12.54	-35.73	-25.00	-10.73	V
7695.22	-33.75	11.46	12.57	-34.86	-25.00	-9.86	V
10260.24	-31.88	12.79	21.23	-40.32	-25.00	-15.32	V
LTE Band 41 / 20MHz / QPSK / RB Size 1 Offset 0/ The Worst Test Results for Middle							
Frequency(MHz)	S G.Lev (dBm)	Ant(dBi)	Loss	PMea	Limit	Margin	Polarity
				(dBm)	(dBm)	(dB)	
5185.96	-33.93	12.72	12.55	-33.76	-25.00	-8.76	H
7779.11	-35.38	11.46	12.57	-36.49	-25.00	-11.49	H
10372.00	-33.28	12.09	21.25	-42.44	-25.00	-17.44	H
5185.96	-35.63	12.80	12.55	-35.38	-25.00	-10.38	V
7779.11	-34.69	13.10	12.57	-34.16	-25.00	-9.16	V
10372.00	-31.75	12.33	21.25	-40.67	-25.00	-15.67	V
LTE Band 41 / 20MHz / QPSK / RB Size 1 Offset 0/ The Worst Test Results for Highest							
Frequency(MHz)	S G.Lev (dBm)	Ant(dBi)	Loss	PMea	Limit	Margin	Polarity
				(dBm)	(dBm)	(dB)	
5289.93	-33.93	12.76	12.57	-33.74	-25.00	-8.74	H
7935.34	-34.11	11.45	12.58	-35.24	-25.00	-10.24	H
10580.28	-32.53	12.28	21.27	-41.52	-25.00	-16.52	H
5289.93	-35.35	12.76	12.57	-35.16	-25.00	-10.16	V
7935.34	-34.19	11.45	12.58	-35.32	-25.00	-10.32	V
10580.28	-32.01	12.28	21.27	-41.00	-25.00	-16.00	V

Remark: Spurious emissions within 30-1000MHz were found more than 20dB below limit line.  
 Test is divided into three directions, X/Y/Z. X pattern for the worst.

## 10. FREQUENCY STABILITY

### 10.1 DESCRIPTION OF FREQUENCY STABILITY MEASUREMENT

#### 10.1.1 MEASUREMENT METHOD

The frequency stability shall be measured by variation of ambient temperature and variation of primary supply voltage to ensure that the fundamental emission stays within the authorized frequency block. The frequency stability of the transmitter shall be maintained within  $\pm 0.00025\%$  ( $\pm 2.5\text{ppm}$ ) of the center frequency.

#### 10.1.2 Test Setup

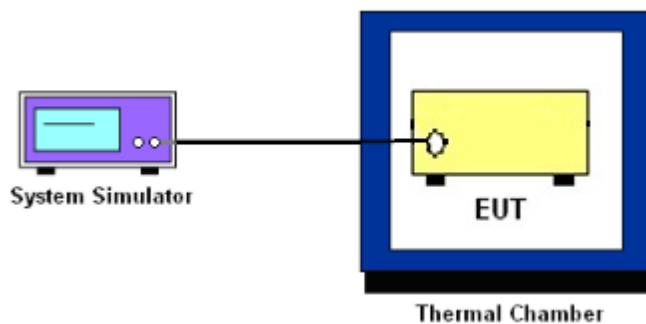

#### 10.1.3 TEST PROCEDURES FOR TEMPERATURE VARIATION

1. The EUT was set up in the thermal chamber and connected with the system simulator.
2. With power OFF, the temperature was decreased to  $-30^{\circ}\text{C}$  and the EUT was stabilized before testing. Power was applied and the maximum change in frequency was recorded within one minute.
3. With power OFF, the temperature was raised in  $10^{\circ}\text{C}$  step up to  $50^{\circ}\text{C}$ . The EUT was stabilized at each step for at least half an hour. Power was applied and the maximum frequency change was recorded within one minute.

#### 10.1.4 TEST PROCEDURES FOR VOLTAGE VARIATION

1. The testing follows FCC KDB 971168 D01v01r03 Section 9.0.
2. The EUT was placed in a temperature chamber at  $25\pm 5^{\circ}\text{C}$  and connected with the system simulator.
3. The power supply voltage to the EUT was varied from 85% to 115% of the nominal value measured at the input to the EUT.
4. The variation in frequency was measured for the worst case.



10.1.4 MEASUREMENT RESULT

LTE BAND 2

LTE Band 2 (QPSK) / 1880MHz / BW10M					
Temperature (°C)	Voltage	Freq. Dev.	Freq. Dev.	Limit	Result
	(Volt)	(Hz)	(ppm)		
50	Normal Voltage	16.78	0.009	2.5ppm	PASS
40		26.19	0.014		
30		29.42	0.016		
20		24.83	0.013		
10		13.13	0.007		
0		24.67	0.013		
-10		35.33	0.019		
-20		17.89	0.010		
-30		12.60	0.007		
25	Maximum Voltage	34.84	0.019		
25	BEP	18.06	0.010		

LTE Band 2 (QPSK) / 1880MHz / BW20M					
Temperature (°C)	Voltage	Freq. Dev.	Freq. Dev.	Limit	Result
	(Volt)	(Hz)	(ppm)		
50	Normal Voltage	22.47	0.012	2.5ppm	PASS
40		26.24	0.014		
30		13.88	0.007		
20		13.84	0.007		
10		29.10	0.015		
0		28.70	0.015		
-10		18.85	0.010		
-20		20.93	0.011		
-30		28.75	0.015		
25	Maximum Voltage	21.16	0.011		
25	BEP	17.81	0.009		

Note: 1. Normal Voltage = 3.85V. ; Battery End Point (BEP) = 3.5 V.; Maximum Voltage = 4.4 V  
 2. Note: The frequency fundamental emissions stay within the authorized frequency block based on the frequency deviation measured is small.



**LTE BAND 4**

LTE Band 4 (QPSK) / 1733MHz / BW10M					
Temperature (°C)	Voltage	Freq. Dev.	Freq. Dev.	Limit	Result
	(Volt)	(Hz)	(ppm)		
50	Normal Voltage	23.12	0.013	2.5ppm	PASS
40		16.08	0.009		
30		26.04	0.015		
20		27.50	0.016		
10		21.71	0.013		
0		14.76	0.009		
-10		20.54	0.012		
-20		32.50	0.019		
-30		24.71	0.014		
25		Maximum Voltage	21.34		
25	BEP	27.08	0.016		

LTE Band 4 (QPSK) / 1733MHz / BW20M					
Temperature (°C)	Voltage	Freq. Dev.	Freq. Dev.	Limit	Result
	(Volt)	(Hz)	(ppm)		
50	Normal Voltage	31.67	0.018	2.5ppm	PASS
40		20.98	0.012		
30		23.32	0.013		
20		26.41	0.015		
10		33.86	0.020		
0		26.33	0.015		
-10		28.45	0.016		
-20		32.77	0.019		
-30		11.60	0.007		
25		Maximum Voltage	20.53		
25	BEP	25.80	0.015		

Note: 1. Normal Voltage = 3.85V. ; Battery End Point (BEP) = 3.5 V.; Maximum Voltage = 4.4 V  
 2. Note: The frequency fundamental emissions stay within the authorized frequency block based on the frequency deviation measured is small.



**LTE BAND 5**

LTE Band 5 (QPSK) / 836.5MHz / BW5M					
Temperature (°C)	Voltage	Freq. Dev.	Freq. Dev.	Limit	Result
	(Volt)	(Hz)	(ppm)		
50	Normal Voltage	29.29	0.041	2.5ppm	PASS
40		35.39	0.050		
30		34.05	0.048		
20		31.72	0.045		
10		19.37	0.027		
0		34.90	0.049		
-10		33.26	0.005		
-20		29.64	0.042		
-30		19.49	0.027		
25		Maximum Voltage	22.66		
25	BEP	21.32	0.030		

LTE Band 5 (QPSK) / 836.5MHz / BW10M					
Temperature (°C)	Voltage	Freq. Dev.	Freq. Dev.	Limit	Result
	(Volt)	(Hz)	(ppm)		
50	Normal Voltage	21.15	0.030	2.5ppm	PASS
40		25.11	0.035		
30		29.64	0.042		
20		29.20	0.041		
10		35.83	0.050		
0		13.89	0.020		
-10		29.50	0.004		
-20		33.39	0.047		
-30		30.24	0.043		
25		Maximum Voltage	18.23		
25	BEP	18.77	0.026		

Note: 1. Normal Voltage = 3.85V. ; Battery End Point (BEP) = 3.5 V.; Maximum Voltage = 4.4V

2. Note: The frequency fundamental emissions stay within the authorized frequency block based on the frequency deviation measured is small.



**LTE BAND 7**

LTE Band 7 (QPSK) / 2535MHz / BW10M					
Temperature (°C)	Voltage	Freq. Dev.	Freq. Dev.	Limit	Result
	(Volt)	(Hz)	(ppm)		
50	Normal Voltage	28.58	0.011	2.5ppm	PASS
40		12.71	0.005		
30		29.67	0.012		
20		22.33	0.009		
10		18.58	0.007		
0		16.58	0.007		
-10		36.18	0.014		
-20		20.53	0.008		
-30		21.99	0.009		
25		Maximum Voltage	31.56		
25	BEP	14.45	0.006		

LTE Band 7 (QPSK) / 2535MHz / BW20M					
Temperature (°C)	Voltage	Freq. Dev.	Freq. Dev.	Limit	Result
	(Volt)	(Hz)	(ppm)		
50	Normal Voltage	11.68	0.005	2.5ppm	PASS
40		35.20	0.014		
30		17.80	0.007		
20		15.77	0.006		
10		13.27	0.005		
0		31.63	0.012		
-10		27.57	0.011		
-20		14.22	0.006		
-30		20.24	0.008		
25		Maximum Voltage	26.98		
25	BEP	36.43	0.014		

Note: 1. Normal Voltage = 3.85V. ; Battery End Point (BEP) = 3.5V.; Maximum Voltage = 4.4 V  
 2. Note: The frequency fundamental emissions stay within the authorized frequency block based on the frequency deviation measured is small.



**LTE BAND 12**

LTE Band 12 (QPSK) / 707.5MHz / BW5M					
Temperature (°C)	Voltage	Freq. Dev.	Freq. Dev.	Limit	Result
	(Volt)	(Hz)	(ppm)		
50	Normal Voltage	13.68	0.019	2.5ppm	PASS
40		12.61	0.018		
30		16.19	0.023		
20		20.20	0.028		
10		22.86	0.032		
0		32.50	0.046		
-10		35.22	0.005		
-20		20.02	0.028		
-30		22.08	0.031		
25	Maximum Voltage	15.80	0.022		
25	BEP	26.53	0.037		

LTE Band 12 (QPSK) / 707.5MHz / BW10M					
Temperature (°C)	Voltage	Freq. Dev.	Freq. Dev.	Limit	Result
	(Volt)	(Hz)	(ppm)		
50	Normal Voltage	31.34	0.044	2.5ppm	PASS
40		15.65	0.022		
30		32.42	0.046		
20		33.52	0.047		
10		35.56	0.050		
0		29.63	0.042		
-10		27.05	0.004		
-20		29.26	0.041		
-30		13.78	0.019		
25	Maximum Voltage	35.65	0.050		
25	BEP	28.55	0.040		

Note: 1. Normal Voltage = 3.85V. ; Battery End Point (BEP) = 3.5V.; Maximum Voltage = 4.4 V  
 2. Note: The frequency fundamental emissions stay within the authorized frequency block based on the frequency deviation measured is small.



**LTE BAND 13**

LTE Band 13 (QPSK) / 782MHz / BW5M					
Temperature (°C)	Voltage	Freq. Dev.	Freq. Dev.	Limit	Result
	(Volt)	(Hz)	(ppm)		
50	Normal Voltage	28.52	0.040	2.5ppm	PASS
40		25.61	0.036		
30		19.58	0.028		
20		17.17	0.024		
10		14.82	0.021		
0		21.83	0.031		
-10		26.66	0.004		
-20		22.79	0.032		
-30		19.07	0.027		
25	Maximum Voltage	31.77	0.045		
25	BEP	22.19	0.031		

LTE Band 13 (QPSK) / 782MHz / BW10M					
Temperature (°C)	Voltage	Freq. Dev.	Freq. Dev.	Limit	Result
	(Volt)	(Hz)	(ppm)		
50	Normal Voltage	16.99	0.024	2.5ppm	PASS
40		33.95	0.048		
30		18.36	0.026		
20		14.60	0.021		
10		19.54	0.028		
0		31.00	0.044		
-10		16.79	0.002		
-20		30.77	0.043		
-30		21.93	0.031		
25	Maximum Voltage	15.18	0.021		
25	BEP	29.14	0.041		

Note: 1. Normal Voltage = 3.85V. ; Battery End Point (BEP) = 3.5V.; Maximum Voltage = 4.4 V  
 2. Note: The frequency fundamental emissions stay within the authorized frequency block based on the frequency deviation measured is small.





**LTE BAND 17**

LTE Band 17 (QPSK) / 2535MHz / BW10M					
Temperature (°C)	Voltage	Freq. Dev.	Freq. Dev.	Limit	Result
	(Volt)	(Hz)	(ppm)		
50	Normal Voltage	13.03	0.005	2.5ppm	PASS
40		32.78	0.013		
30		34.71	0.014		
20		32.04	0.013		
10		17.87	0.007		
0		14.47	0.006		
-10		23.79	0.009		
-20		20.77	0.008		
-30		24.83	0.010		
25		Maximum Voltage	28.73		
25	BEP	23.51	0.009		

LTE Band 17 (QPSK) / 2535MHz / BW20M					
Temperature (°C)	Voltage	Freq. Dev.	Freq. Dev.	Limit	Result
	(Volt)	(Hz)	(ppm)		
50	Normal Voltage	20.31	0.008	2.5ppm	PASS
40		13.17	0.005		
30		25.27	0.010		
20		30.76	0.012		
10		34.10	0.013		
0		23.07	0.009		
-10		19.67	0.008		
-20		33.65	0.013		
-30		32.20	0.013		
25		Maximum Voltage	30.20		
25	BEP	26.10	0.010		

Note: 1. Normal Voltage = 3.85V. ; Battery End Point (BEP) = 3.5V.; Maximum Voltage = 4.4 V  
 2. Note: The frequency fundamental emissions stay within the authorized frequency block based on the frequency deviation measured is small.



**LTE BAND 25**

LTE Band 25 (QPSK) / 1880MHz / BW10M					
Temperature (°C)	Voltage	Freq. Dev.	Freq. Dev.	Limit	Result
	(Volt)	(Hz)	(ppm)		
50	Normal Voltage	20.12	0.011	2.5ppm	PASS
40		13.57	0.007		
30		36.24	0.019		
20		31.77	0.017		
10		34.90	0.019		
0		21.80	0.012		
-10		15.97	0.008		
-20		31.49	0.017		
-30		22.35	0.012		
25		Maximum Voltage	13.68		
25	BEP	12.88	0.007		

LTE Band 25 (QPSK) / 1880MHz / BW20M					
Temperature (°C)	Voltage	Freq. Dev.	Freq. Dev.	Limit	Result
	(Volt)	(Hz)	(ppm)		
50	Normal Voltage	27.57	0.015	2.5ppm	PASS
40		13.17	0.007		
30		28.21	0.015		
20		30.12	0.016		
10		24.07	0.013		
0		19.78	0.011		
-10		19.77	0.011		
-20		14.34	0.008		
-30		20.03	0.011		
25		Maximum Voltage	35.86		
25	BEP	15.07	0.008		

Note: 1. Normal Voltage = 3.85V. ; Battery End Point (BEP) = 3.5V.; Maximum Voltage = 4.4 V  
 2. Note: The frequency fundamental emissions stay within the authorized frequency block based on the frequency deviation measured is small.



LTE BAND 26

LTE Band 26 (QPSK) / 1733MHz / BW10M					
Temperature (°C)	Voltage	Freq. Dev.	Freq. Dev.	Limit	Result
	(Volt)	(Hz)	(ppm)		
50	Normal Voltage	22.24	0.013	2.5ppm	PASS
40		21.68	0.013		
30		26.39	0.015		
20		30.60	0.018		
10		21.98	0.013		
0		28.65	0.017		
-10		24.43	0.014		
-20		30.85	0.018		
-30		20.75	0.012		
25	Maximum Voltage	12.41	0.007		
25	BEP	28.96	0.017		

LTE Band 26 (QPSK) / 1733MHz / BW20M					
Temperature (°C)	Voltage	Freq. Dev.	Freq. Dev.	Limit	Result
	(Volt)	(Hz)	(ppm)		
50	Normal Voltage	34.53	0.020	2.5ppm	PASS
40		34.05	0.020		
30		24.73	0.014		
20		21.58	0.012		
10		34.34	0.020		
0		29.29	0.017		
-10		16.70	0.010		
-20		32.82	0.019		
-30		29.85	0.017		
25	Maximum Voltage	36.37	0.021		
25	BEP	23.39	0.013		

Note: 1. Normal Voltage = 3.85V. ; Battery End Point (BEP) = 3.5V.; Maximum Voltage = 4.4 V  
 2. Note: The frequency fundamental emissions stay within the authorized frequency block based on the frequency deviation measured is small.



LTE BAND41

LTE Band 41 (QPSK) / 2593MHz / BW10M					
Temperature (°C)	Voltage	Freq. Dev.	Freq. Dev.	Limit	Result
	(Volt)	(Hz)	(ppm)		
50	Normal Voltage	21.31	0.008	2.5ppm	PASS
40		30.77	0.012		
30		17.06	0.007		
20		32.78	0.013		
10		33.03	0.013		
0		19.90	0.008		
-10		25.68	0.010		
-20		28.38	0.011		
-30		15.01	0.006		
25		Maximum Voltage	34.58		
25	BEP	24.74	0.010		

LTE Band 41 (QPSK) / 2593MHz / BW20M					
Temperature (°C)	Voltage	Freq. Dev.	Freq. Dev.	Limit	Result
	(Volt)	(Hz)	(ppm)		
50	Normal Voltage	20.29	0.008	2.5ppm	PASS
40		31.36	0.012		
30		21.59	0.009		
20		25.33	0.010		
10		34.21	0.013		
0		16.81	0.007		
-10		26.62	0.011		
-20		26.82	0.011		
-30		19.46	0.008		
25		Maximum Voltage	31.85		
25	BEP	33.15	0.013		

Note: 1. Normal Voltage = 3.85V. ; Battery End Point (BEP) = 3.5V.; Maximum Voltage = 4.4 V  
 2. Note: The frequency fundamental emissions stay within the authorized frequency block based on the frequency deviation measured is small.

# PHOTOS OF TEST SETUP

## RADIATED SPURIOUS EMISSION

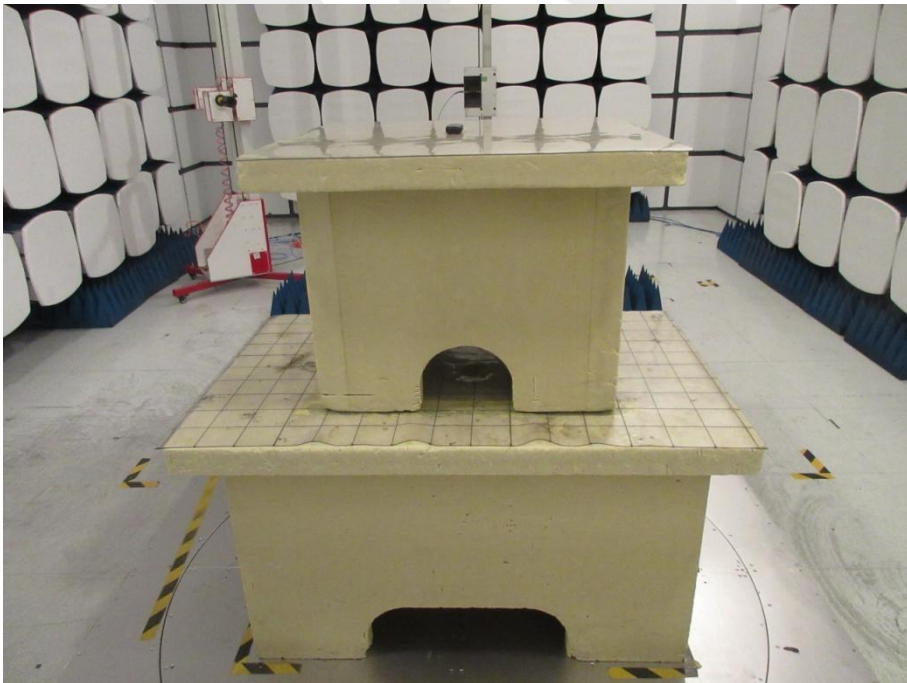
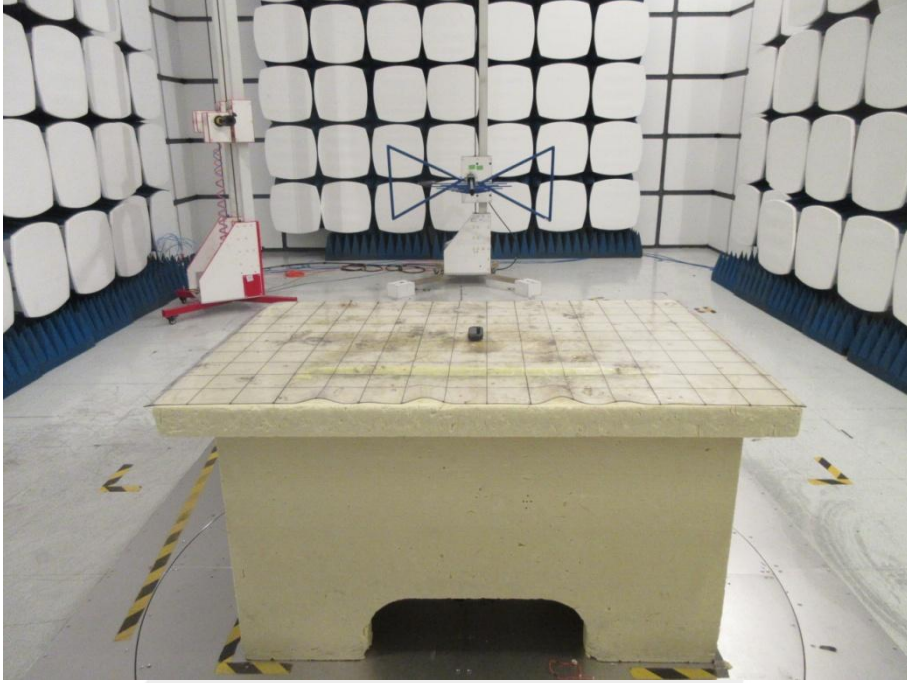

\*\*\*\*\*END OF THE REPORT\*\*\*\*\*