

Report on the Radio Testing

For

Rentokil Initial 1927 plc

on

Control Panel / Autogate / Radar R

Report no. TRA-033559-45-00C

15 June 2018

RF916 7.0

Report Number: TRA-033559-45-00C
Issue: C

REPORT ON THE RADIO TESTING OF A
Rentokil Initial 1927 plc
Control Panel / Autogate / Radar R
WITH RESPECT TO SPECIFICATION
FCC 47CFR 15.247 & IC RSS-247

TEST DATE: 13/01/2017 to 28/04/2017

Written by: A Longley

A Longley
Radio Test Engineer

Approved by:

J Charters
Department Manager - Radio

Date: 15 June 2018

Disclaimers:

- [1] THIS DOCUMENT MAY BE REPRODUCED ONLY IN ITS ENTIRETY AND WITHOUT CHANGE
- [2] THE RESULTS CONTAINED IN THIS DOCUMENT RELATE ONLY TO THE ITEM(S) TESTED

RF916 7.0

1 Revision Record

<i>Issue Number</i>	<i>Issue Date</i>	<i>Revision History</i>
A	3 rd August 2017	Original
B	7 th February 2018	Typos corrected, SAR assessment replaced with MPE calculation
C	15 June 2018	Carrier Power results corrected, MPE recalculated

2 Summary

TEST REPORT NUMBER:	TRA-033559-45-00C
WORKS ORDER NUMBER	TRA-033559-05
PURPOSE OF TEST:	<p>USA: Testing of radio frequency equipment per the relevant authorization procedure of chapter 47 of CFR (code of federal regulations) Part 2, subpart J.</p> <p>Canada: Testing of radio apparatus for TAC (technical acceptance certificate) per subsections 4(2) of the Radio communication Act and 21(1) of the Radio communication Regulations.</p>
TEST SPECIFICATION(S):	47CFR15.247 & RSS-247
EQUIPMENT UNDER TEST (EUT):	Control Panel / Autogate / Radar R
FCC IDENTIFIER:	2AK3PGSD-500349
ISED ID	22407-GSD500349
EUT SERIAL NUMBER:	Prototype
MANUFACTURER/AGENT:	Rentokil Initial 1927 plc
ADDRESS:	<p>Marketing and Innovation Riverbank Meadows Business Park Camberley GU17 9AB United Kingdom</p>
CLIENT CONTACT:	<p>Ning Pan ☎ 01276536676 ✉ ning.pan@rentokil-initial.com</p>
TEST DATE:	13/01/2017 to 28/04/2017
TESTED BY:	<p>A Longley Element</p>

2.1 Test Summary

Test Method and Description	Requirement Clause		Applicable to this equipment	Result / Note
	RSS	47CFR15		
Radiated spurious emissions (restricted bands of operation and cabinet radiation)	Gen, 8.10	15.205	☒	Pass
AC power line conducted emissions	Gen, 8.8	15.207	☒	Pass
Carrier frequency separation	247, 5.1 (2)	15.247(a)(1)	☒	Pass
Number of hopping channels	247, 5.1 (3), (4) and (5)	15.247(a)(1) (i), (ii) and (iii)	☒	Pass
Average time of occupancy	247, 5.1 (3), (4) and (5)	15.247(a)(1) (i), (ii) and (iii) and (f)	☒	Pass
Maximum peak conducted output power	247, 5.4 (1), (2) and (3)	15.247 (a)(1), (b)(1) and (b)(2)	☒	Pass
20dB emission bandwidth	247, 5.1 (1)	15.247(a)(1) (i) and (ii)	☒	Pass
Out-of-band emissions	247, 5.5	15.247(d)	☒	Pass
Power Spectral Density	247, 5.2 (2)	15.247(e)	☒	Pass

Notes:

The results contained in this report relate only to the items tested, in the condition at time of test, and were obtained in the period between the date of initial receipt of samples and the date of issue of the report.

The apparatus was set up and exercised using the configurations, modes of operation and arrangements defined in this report only. Any modifications made are identified in Section 8 of this report.

Particular operating modes, apparatus monitoring methods and performance criteria required by the standards tested to have been performed except where identified in Section 5.2 of this test report (Deviations from Test Standards).

3 Contents

1	Revision Record.....	3
2	Summary.....	4
2.1	Test Summary.....	5
3	Contents.....	6
4	Introduction.....	8
5	Test Specifications.....	9
5.1	Normative References.....	9
5.2	Deviations from Test Standards.....	9
6	Glossary of Terms.....	10
7	Equipment Under Test.....	11
7.1	EUT Identification.....	11
7.2	System Equipment.....	11
7.3	EUT Mode of Operation.....	11
7.3.1	Transmission.....	11
7.3.2	Reception.....	11
7.4	EUT Radio Parameters.....	12
7.4.1	General.....	12
7.4.2	Antennas.....	12
7.4.3	Product specific declarations.....	13
7.5	EUT Description.....	13
8	Modifications.....	14
9	EUT Test Setup.....	15
9.1	Block Diagram.....	15
9.2	General Set-up Photograph.....	16
10	General Technical Parameters.....	17
10.1	Normal Conditions.....	17
10.2	Varying Test Conditions.....	17
11	Radiated emissions.....	18
11.1	Definitions.....	18
11.2	Test Parameters.....	18
11.3	Test Limit.....	18
11.4	Test Method.....	19
11.5	Test Equipment.....	20
11.6	Test Results – Control Panel.....	21
11.7	Test Results – Auto Gate.....	28
11.8	Test Results – Mouse Radar.....	35
12	AC power-line conducted emissions.....	42
12.1	Definition.....	42
12.2	Test Parameters.....	42
12.3	Test Method.....	43
12.4	Test Set-up Photograph.....	44
12.5	Test Equipment.....	44
12.6	Test Results.....	45
13	Carrier frequency separation.....	46
13.1	Definition.....	46
13.2	Test Parameters.....	46
13.3	Test Limit.....	46
13.4	Test Method.....	47
13.5	Test Equipment.....	47
13.6	Test Results.....	47
14	Number of hopping frequencies.....	49
14.1	Definition.....	49
14.2	Test Parameters.....	49
14.3	Test Limit.....	49
14.4	Test Method.....	50
14.5	Test Equipment.....	50
14.6	Test Results.....	50
15	Average channel occupancy.....	52
15.1	Definition.....	52
15.2	Test Parameters.....	52
15.3	Test Limit.....	52
15.4	Test Method.....	53
15.5	Test Equipment.....	53

15.6	Test Results	53
16	Maximum peak conducted output power	55
16.1	Definition	55
16.2	Test Parameters	55
16.3	Test Limit	55
16.4	Test Method	56
16.5	Test Equipment	56
16.6	Test Results	57
17	Occupied Bandwidth	59
17.1	Definition	59
17.2	Test Parameters	59
17.3	Test Limit	59
17.4	Test Method	60
17.5	Test Equipment	60
17.6	Test Results	61
18	Out-of-band and conducted spurious emissions	63
18.1	Definition	63
18.2	Test Parameters	63
18.3	Test Limits	63
18.4	Test Method	64
18.5	Test Equipment	64
18.6	Test Results	65
19	Power spectral density	79
19.1	Definition	79
19.2	Test Parameters	79
19.3	Test Limit	79
19.4	Test Method	80
19.5	Test Equipment	80
19.6	Test Results	81
20	Measurement Uncertainty	83
21	RF Exposure	84

4 Introduction

This report TRA-033559-45-00C presents the results of the Radio testing on a Rentokil Initial 1927 plc, Control Panel / Autogate / Radar R to specification 47CFR15 Radio Frequency Devices and RSS-247 Licence-exempt Radio Apparatus (All Frequency Bands): Category I Equipment.

The testing was carried out for Rentokil Initial 1927 plc by Element, at the address(es) detailed below.

<input checked="" type="checkbox"/>	Element Hull Unit E South Orbital Trading Park Hedon Road Hull HU9 1NJ UK	<input type="checkbox"/>	Element Skelmersdale Unit 1 Pendle Place Skemersdale West Lancashire WN8 9PN UK
-------------------------------------	---	--------------------------	---

This report details the configuration of the equipment, the test methods used and any relevant modifications where appropriate.

All test and measurement equipment under the control of the laboratory and requiring calibration is subject to an established programme and procedures to control and maintain measurement standards. The quality management system meets the principles of ISO 9001, and has quality control procedures for monitoring the validity of tests undertaken. Records and sufficient detail are retained to establish an audit trail of calibration records relating to its test results for a defined period. Under control of the established calibration programme, key quantities or values of the test & measurement instrumentation are within specification and comply with the relevant traceable internationally recognised and appropriate standard specifications, which are UKAS calibrated as such where these properties have a significant effect on results. Participation in inter-laboratory comparisons and proficiency testing ensures satisfactory correlation of results conform to Elements own procedures, as well as statistical techniques for analysis of test data providing the appropriate confidence in measurements.

Throughout this report EUT denotes equipment under test.

FCC Site Listing:

Element is accredited for the above sites under the US-EU MRA, Designation number UK0009.

IC Registration Number(s):

Element Hull	3483A
Element North West	3930B

The test site requirements of ANSI C63.4-2014 are met up to 1GHz.

The test site SVSWR requirements of CISPR 16-1-4:2010 are met over the frequency range 1 GHz to 18 GHz.

5 Test Specifications

5.1 Normative References

- FCC 47 CFR Ch. I – Part 15 – Radio Frequency Devices.
- ANSI C63.10-2013 – American National Standard of Procedures for Compliance Testing of Unlicensed Wireless Devices.
- ANSI C63.4-2014 – American National Standard for Methods of Measurement of Radio-Noise Emissions from Low-Voltage Electrical and Electronic Equipment in the Range of 9 kHz to 40 GHz.
- Industry Canada RSS-247, Issue 1, May 2015 – Digital Transmission Systems (DTSs), Frequency Hopping Systems (FHSs) and Licence-Exempt Local Area Network (LE-LAN) Devices
- Industry Canada RSS-Gen, Issue 4, November 2014 – General Requirements for Compliance of Radio Apparatus.

5.2 Deviations from Test Standards

There were no deviations from the test standard.

6 Glossary of Terms

§	denotes a section reference from the standard, not this document
AC	Alternating Current
ANSI	American National Standards Institute
BW	bandwidth
C	Celsius
CFR	Code of Federal Regulations
CW	Continuous Wave
dB	decibel
dBm	dB relative to 1 milliwatt
DC	Direct Current
DSSS	Direct Sequence Spread Spectrum
EIRP	Equivalent Isotropically Radiated Power
ERP	Effective Radiated Power
EUT	Equipment Under Test
FCC	Federal Communications Commission
FHSS	Frequency Hopping Spread Spectrum
Hz	hertz
IC	Industry Canada
ITU	International Telecommunication Union
LBT	Listen Before Talk
m	metre
max	maximum
MIMO	Multiple Input and Multiple Output
min	minimum
MRA	Mutual Recognition Agreement
N/A	Not Applicable
PCB	Printed Circuit Board
PDF	Portable Document Format
Pt-mpt	Point-to-multipoint
Pt-pt	Point-to-point
RF	Radio Frequency
RH	Relative Humidity
RMS	Root Mean Square
Rx	receiver
s	second
SVSWR	Site Voltage Standing Wave Ratio
Tx	transmitter
UKAS	United Kingdom Accreditation Service
V	volt
W	watt
Ω	ohm

7 Equipment Under Test

7.1 EUT Identification

- Name: Control Panel / Autogate / Radar R
- Serial Number: Prototype
- Model Number: Radar R (304778); AutoGate Connect (304765); Control Panel (304768)
- Software Revision: Not Applicable
- Build Level / Revision Number: Not Applicable

7.2 System Equipment

Equipment listed below forms part of the overall test setup and is required for equipment functionality and/or monitoring during testing. The compliance levels achieved in this report relate only to the EUT and not items given in the following list.

Laptop PC.

7.3 EUT Mode of Operation

7.3.1 Transmission

The mode of operation for Tx tests was as follows:-

The EUT was placed into continuous Tx modes using the "hardware_test_r428.bin" firmware, when hopping operation was required the standard firmware version "module_r422.bin" was used.

7.3.2 Reception

The mode of operation for Rx tests was as follows:-

The EUT was placed into continuous Rx modes using the "hardware_test_r428.bin" firmware.

7.4 EUT Radio Parameters

7.4.1 General

Frequency of operation:	915.25 to 927.5 MHz
Modulation type(s):	Phase
Occupied channel bandwidth(s):	125 kHz
Channel spacing:	250 kHz
ITU emission designator(s):	125G1DEX
Declared output power(s):	14 dBm
Warning against use of alternative antennas in user manual (yes/no):	yes
Nominal Supply Voltage:	6 Vdc
Location of notice for license exempt use:	Label / user manual / both.
Method of prevention of use on non-US / non-Canadian frequencies:	Set by server, which takes its information from the connected cell tower.
Duty cycle:	Control Panel <10% / others <1%

7.4.2 Antennas

Type:	Fixed antenna
Frequency range:	915.25 to 927.5 MHz
Impedance:	50Ω
SWR:	Unknown
Gain:	Unknown but < 6dBi
Polarisation:	Linear
Beam width:	Unknown
Connector type:	Soldered to PCB
Length:	12 cm
Weight:	Unknown
Environmental limits:	-20 C to 50 C
Mounting:	Soldered to PCB

7.4.3 Product specific declarations

Multiple antenna configuration(s), e.g. MIMO:	Single antenna only
Fixed pt-pt operations (yes/no):	no
Installation manual advice on pt-pt operational restrictions (yes/no):	n/a
Fixed pt-mpt operations (yes/no):	no
Simultaneous tx (yes/no):	n/a

7.5 EUT Description

The EUT is a LoRa module installed in a Control Panel and pest traps to monitor trap operation.

8 Modifications

No modifications were performed during this assessment.

9 EUT Test Setup

9.1 Block Diagram

The following diagram shows basic EUT interconnections with cable type and cable lengths identified:

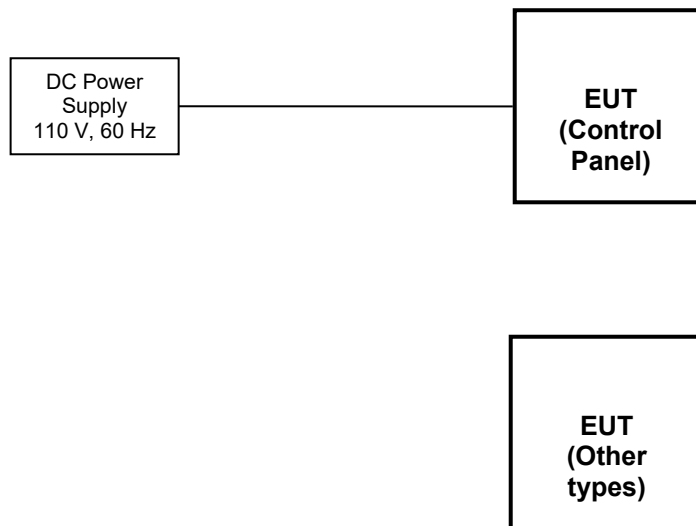

9.2 General Set-up Photograph

The following photograph shows basic EUT set-up (all 3 EUTs are shown during EMC testing, radio testing was performed on individual units):



10 General Technical Parameters

10.1 Normal Conditions

The E U T was tested under the normal environmental conditions of the test laboratory, except where otherwise stated. The normal power source applied was approx. 6 V dc from the adaptor (Control Panel) or 6 V dc from the battery for other types.

10.2 Varying Test Conditions

There are no specific frequency stability requirements for the type of device. The results contained in this report demonstrate that the occupied bandwidth is contained within the authorised band and the manufacturer has declared sufficient frequency stability (refer to section 7.4).

Variation of supply voltage is required to ensure stability of the declared output power. During carrier power testing the following variations were made:

	Category	Nominal	Variation
<input type="checkbox"/>	Mains	110 V ac +/-2 %	85 % and 115 %
<input checked="" type="checkbox"/>	Battery	New battery	N/A

11 Radiated emissions

11.1 Definitions

Spurious emissions

Emissions on a frequency or frequencies, which are outside the necessary bandwidth and the level of which may be reduced without affecting the corresponding transmission of information. Spurious emissions include harmonic emissions, parasitic emissions, intermodulation products and frequency conversion products, but exclude out-of-band emissions.

Restricted bands

A frequency band in which intentional radiators are permitted to radiate only spurious emissions but not fundamental signals.

11.2 Test Parameters

Test Location:	Element Hull
Test Chamber:	Lab 16
Test Standard and Clause:	ANSI C63.10-2013, Clause 6.5 and 6.6
EUT Channels / Frequencies Measured:	Low / Mid / High
EUT Channel Bandwidths:	200 kHz
Deviations From Standard:	None
Measurement BW:	30 MHz to 1 GHz: 120 kHz Above 1 GHz: 1 MHz
Measurement Detector:	Up to 1 GHz: quasi-peak Above 1 GHz: RMS average and Peak

Environmental Conditions (Normal Environment)

Temperature: 22 °C	+15 °C to +35 °C (as declared)
Humidity: 33 % RH	20 % RH to 75 % RH (as declared)
Supply: 6 V dc (Control Panel 110Vac)	

11.3 Test Limit

Unwanted emissions that fall within the restricted frequency bands shall comply with the limits specified:

General Field Strength Limits for License-Exempt Transmitters at Frequencies above 30 MHz

<i>Frequency (MHz)</i>	<i>Field Strength (μV/m at 3 m)</i>
30 to 88	100
88 to 216	150
216 to 960	200
Above 960	500

11.4 Test Method

With the EUT setup as per section 9 of this report and connected as per Figure i, the emissions from the EUT were measured on a spectrum analyzer / EMI receiver.

Radiated electromagnetic emissions from the EUT are checked first by preview scans. Preview scans for all spectrum and modulation characteristics are checked, using a peak detector and where applicable worst-case determined for function, operation, orientation, etc. for both vertical and horizontal polarisations. Pre-scan plots are shown with a peak detector and 100 kHz RBW.

If the EUT connects to auxiliary equipment and is table or floor standing, the configurations prescribed in ANSI C63.10 are followed. Alternatively, a layout closest to normal use (as declared by the provider) is employed, (see EUT setup photographs for more detail).

Emissions between 30 MHz and 1 GHz are measured using calibrated broadband antennas. Emissions above 1 GHz are characterized using standard gain horn antennas. Pre-amplifiers and filters are used where required. Care is taken to ensure that test receiver resolution bandwidth, video bandwidth and detector type(s) meet the regulatory requirements.

For both horizontal and vertical polarizations, the EUT is then rotated through 360 degrees in azimuth until the highest emission is detected. At the previously determined azimuth the test antenna is raised and lowered from 1 to 4 m in height until a maximum emission level is detected, this maximum value is recorded.

Power values measured on the test receiver / analyzer are converted to field strength, FS, in dB μ V/m at the regulatory distance, using:

$$FS = PR + CL + AF - PA + DC - CF$$

Where,

PR is the power recorded on the receiver / spectrum analyzer in dB μ V;
 CL is the cable loss in dB;
 AF is the test antenna factor in dB/m;
 PA is the pre-amplifier gain in dB (where used);
 DC is the duty correction factor in dB (where used, e.g. harmonics of pulsed fundamental);
 CF is the distance factor in dB (where measurement distance different to limit distance);

This field strength value is then compared with the regulatory limit.

Figure i Test Setup

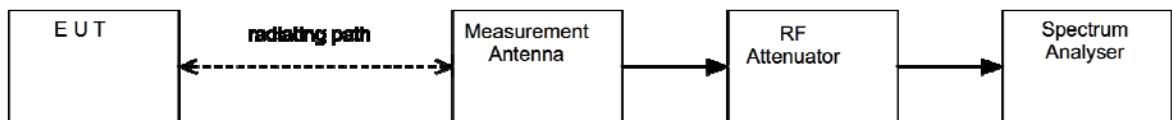

11.5 Test Equipment

Equipment Type	Manufacturer	Equipment Description	Element No	Due For Calibration
FSV	Rohde & Schwarz	Spectrum Analyser	N/A	07/06/2017
FSU46	R&S	Spectrum Analyser	REF910	05/07/2017
3109	EMCO	Biconical Antenna	RFG095	17/05/2019
3146	EMCO	Log Periodic Antenna	RFG191	17/05/2019
3115	EMCO	Horn Antenna	RFG129	09/02/2018
310	Sonoma	Pre-Amp (9kHz – 1GHz)	REF927	30/06/2018
8449B	Agilent	Pre-Amp (1 – 26.5GHz)	REF913	02/02/2018

11.6 Test Results – Control Panel

Channel 6 : 915.25 MHz

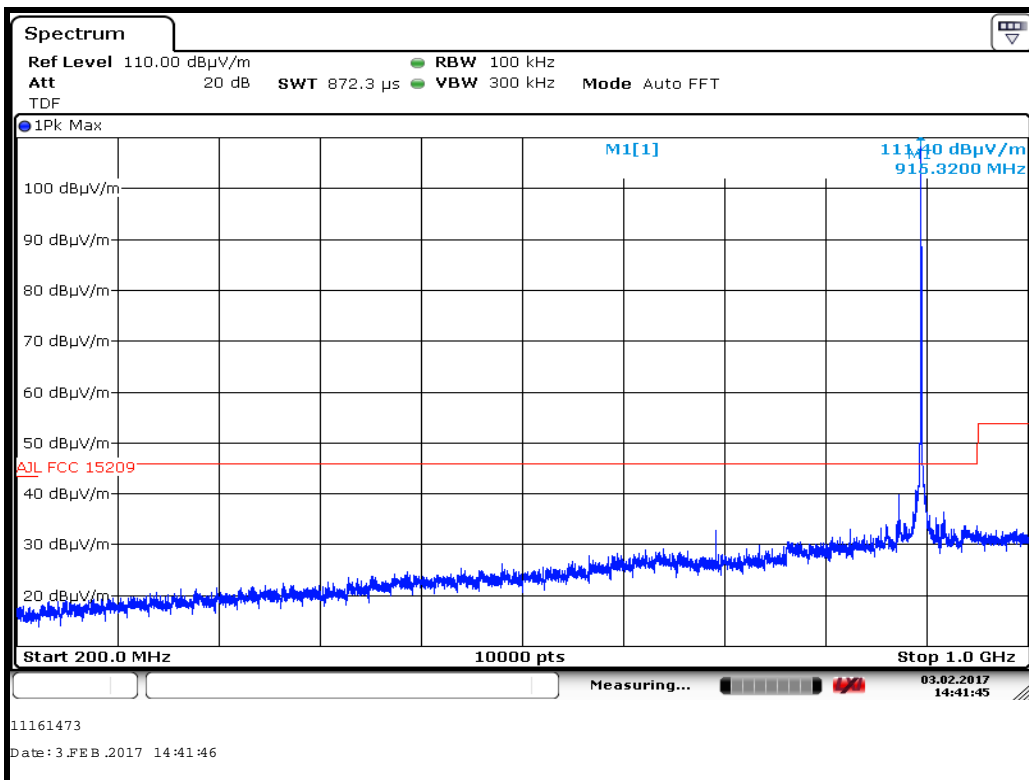
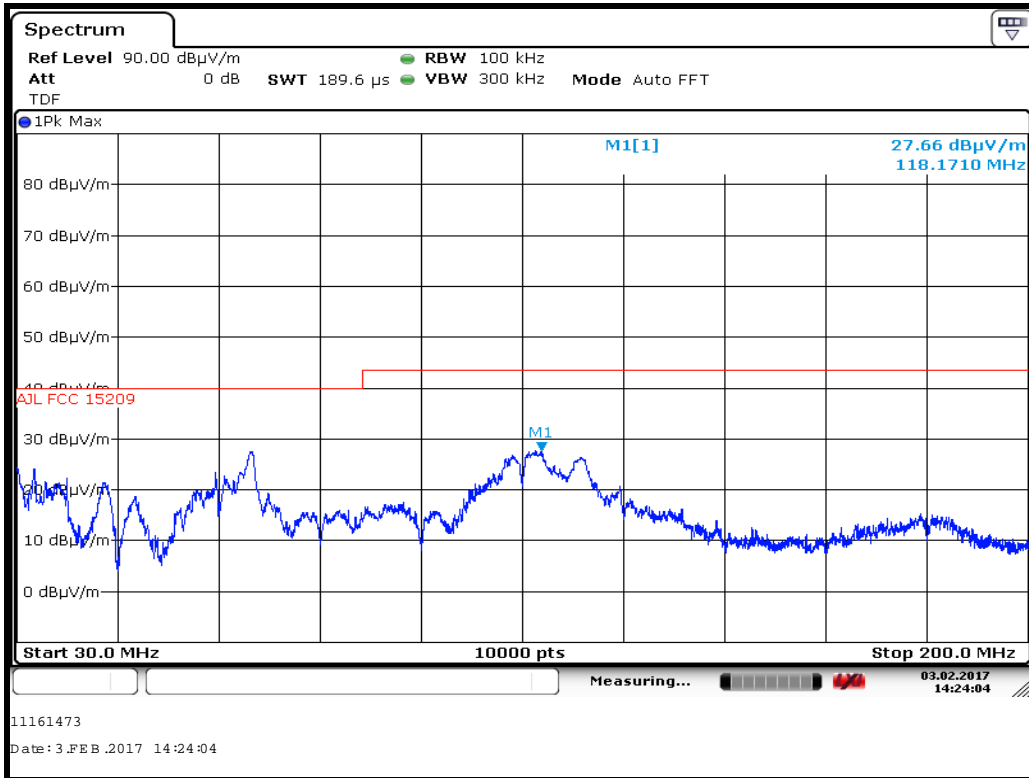

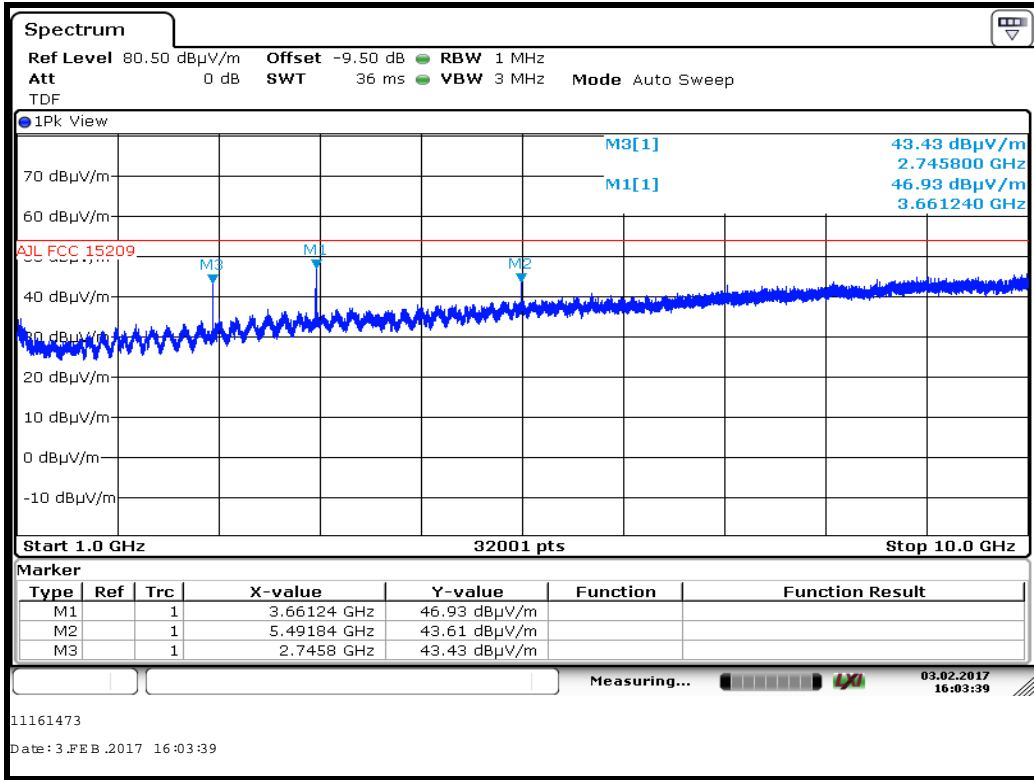

Channel 29 : 921 MHz

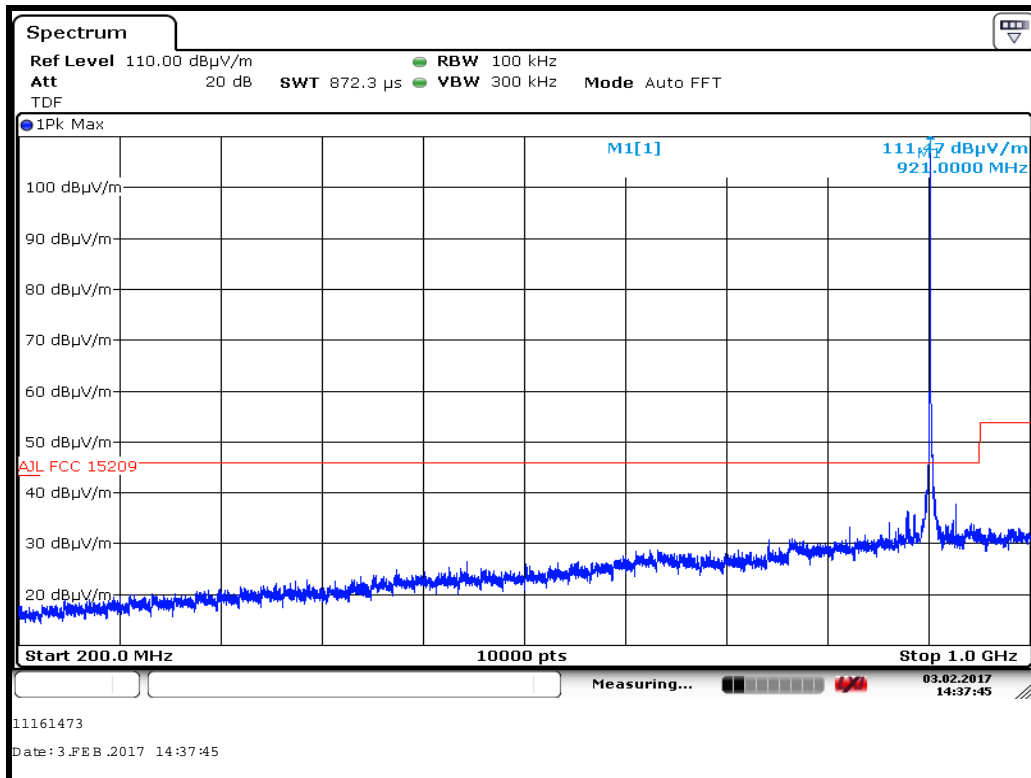
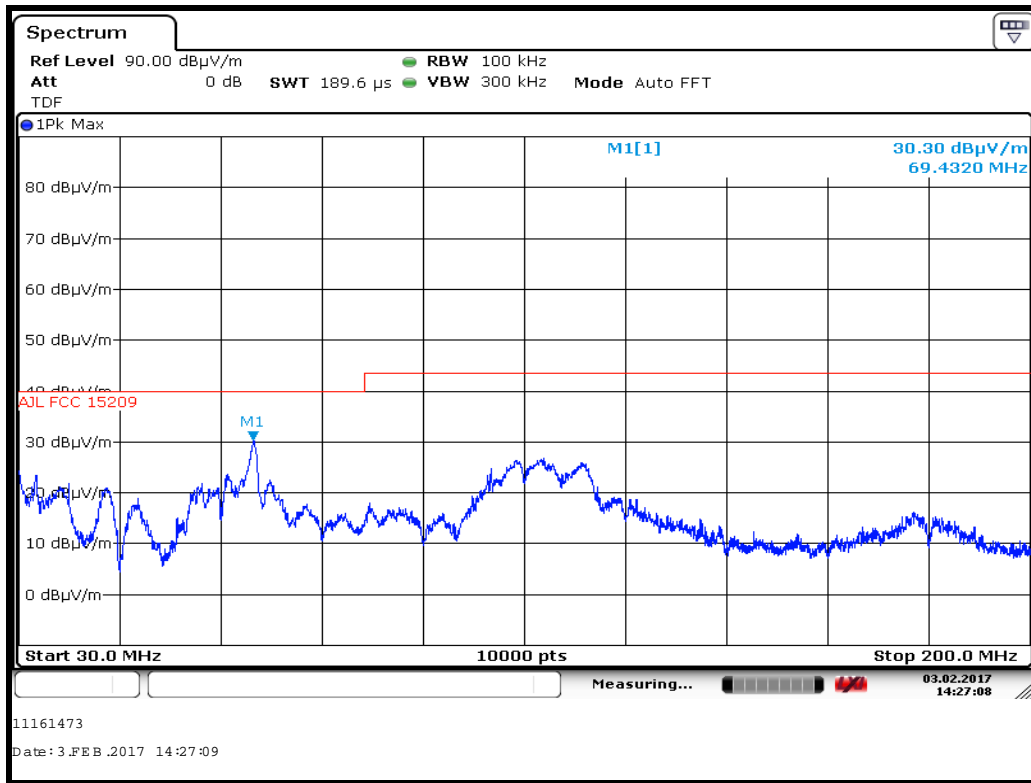

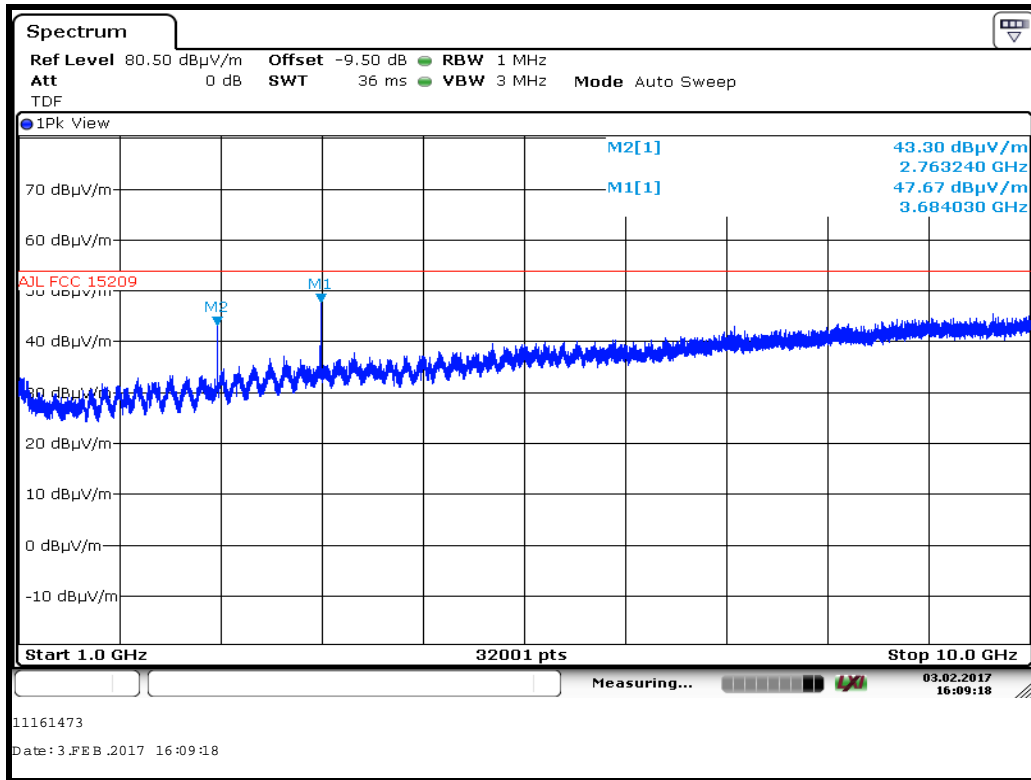

Channel 55 : 927.50

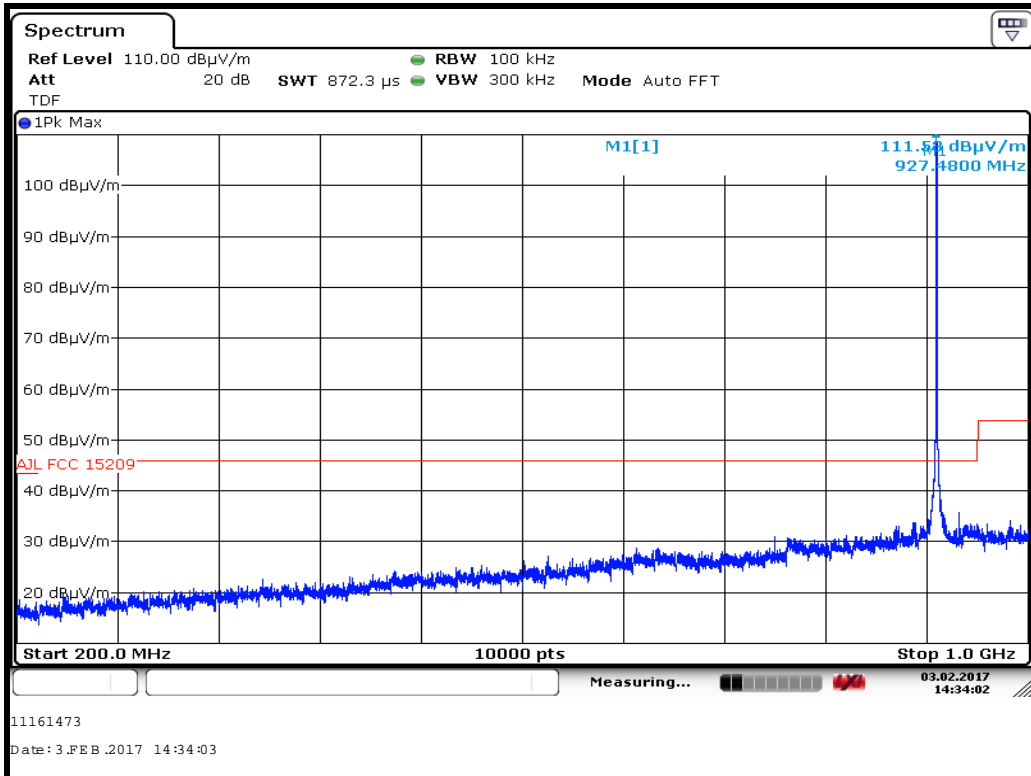
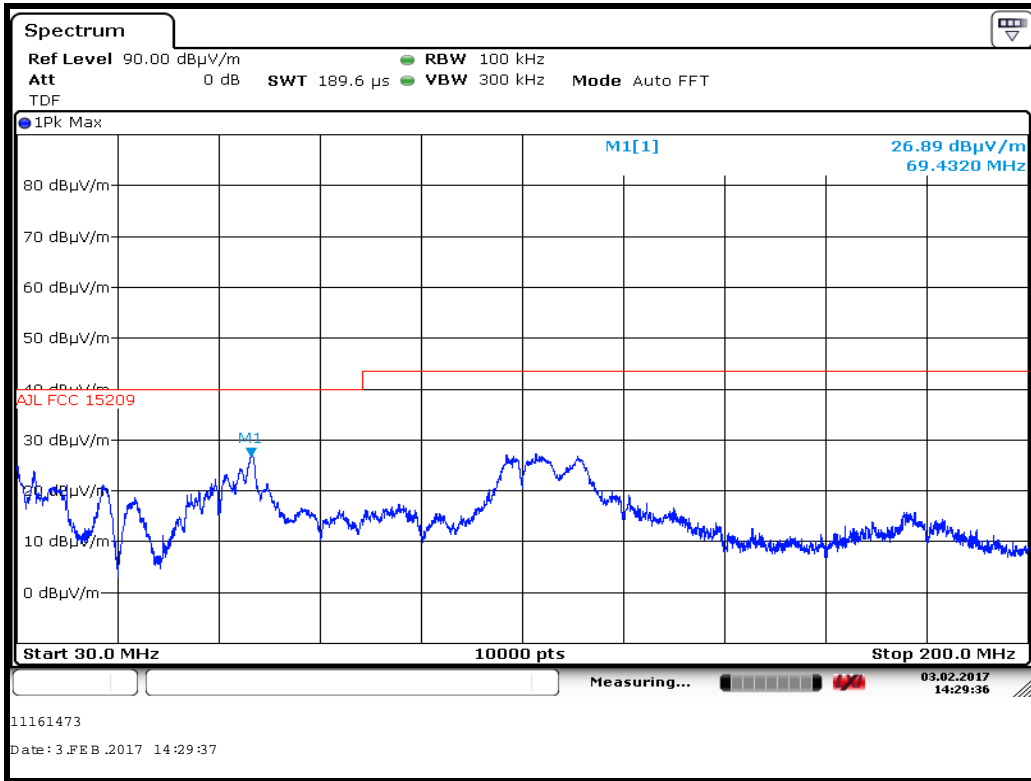

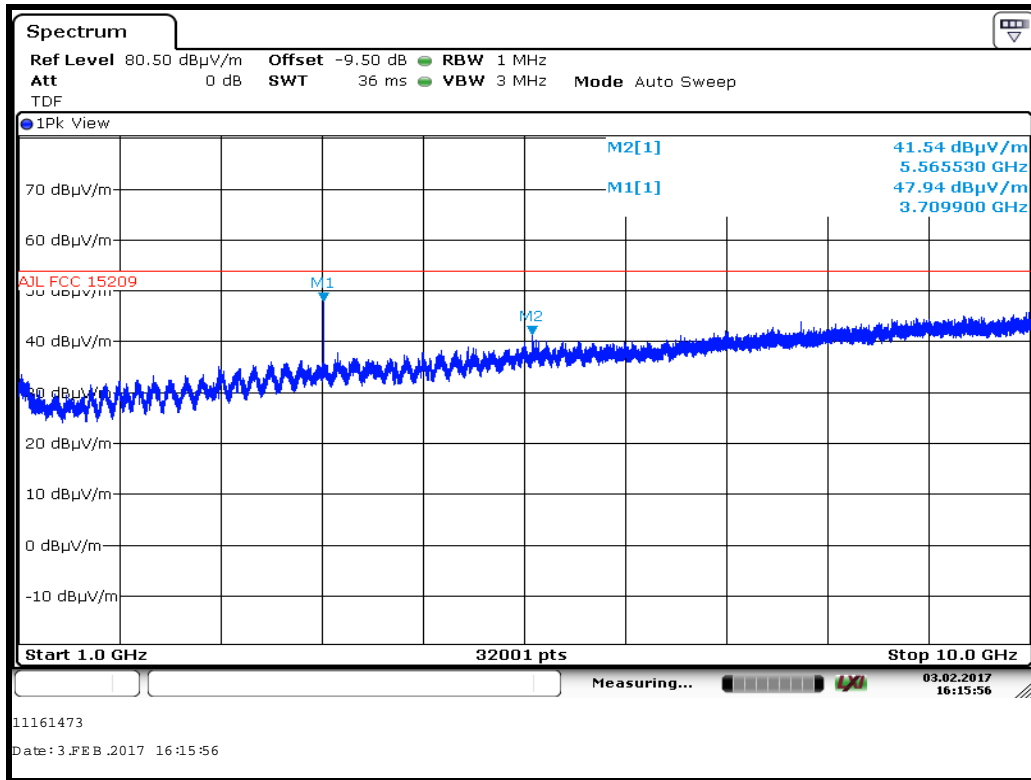

High Power; Channel: 915.25 MHz										
Detector	Freq. (MHz)	Meas'd Emission (dBμV)	Cable Loss (dB)	Antenna Factor (dB/m)	Pre-amp Gain (dB)	Duty Cycle Corr'n (dB)	Distance Extrap'n Factor (dB)	Field Strength (dBμV/m)	Field Strength (μV/m)	Limit (μV/m)
QP	120.02	48.70	1.2	11.9	32.5	0	0	29.3	29.17	150
QP	132.01	36.70	1.2	12.5	32.5	0	0	18.0	7.94	150
QP	960.10	35.50	3.3	21.9	31.3	0	0	29.4	29.51	500
Pk	2745.65	57.92	3.8	29.3	35.3	0	-9.5	46.16	203.24	5000
Av	2745.65	55.78	3.8	29.3	35.3	0	-9.5	44.02	158.85	500
Pk	3661.04	56.69	4.6	31.6	35.4	0	-9.5	47.99	250.90	5000
Av	3661.04	53.75	4.6	31.6	35.4	0	-9.5	45.05	178.85	500

High Power; Channel: 921.00 MHz										
Detector	Freq. (MHz)	Meas'd Emission (dBμV)	Cable Loss (dB)	Antenna Factor (dB/m)	Pre-amp Gain (dB)	Duty Cycle Corr'n (dB)	Distance Extrap'n Factor (dB)	Field Strength (dBμV/m)	Field Strength (μV/m)	Limit (μV/m)
QP	120.02	48.70	1.2	11.9	32.5	0	0	29.3	29.17	150
QP	132.01	36.70	1.2	12.5	32.5	0	0	18.0	7.94	150
QP	960.10	35.50	3.3	21.9	31.3	0	0	29.4	29.51	500
Pk	2763.09	57.43	4.2	29.4	35.3	0.0	-9.5	46.16	203.24	5000
Av	2763.09	54.89	4.2	29.4	35.3	0.0	-9.5	43.62	151.71	500
Pk	3684.03	58.29	4.6	31.6	35.4	0.0	-9.5	49.59	301.65	5000
Av	3684.03	56.05	4.6	31.6	35.4	0.0	-9.5	47.35	233.08	500

High Power; Channel: 927.50 MHz										
Detector	Freq. (MHz)	Meas'd Emission (dBμV)	Cable Loss (dB)	Antenna Factor (dB/m)	Pre-amp Gain (dB)	Duty Cycle Corr'n (dB)	Distance Extrap'n Factor (dB)	Field Strength (dBμV/m)	Field Strength (μV/m)	Limit (μV/m)
QP	120.02	48.70	1.2	11.9	32.5	0	0	29.3	29.17	150
QP	132.01	36.70	1.2	12.5	32.5	0	0	18.0	7.94	150
QP	960.10	35.50	3.3	21.9	31.3	0	0	29.4	29.51	500
Pk	3709.90	57.80	4.6	31.7	35.4	0	-9.5	49.20	288.40	5000
Av	3709.90	55.15	4.6	31.7	35.4	0	-9.5	46.55	212.57	500

11.7 Test Results – Auto Gate

Channel 6 : 915.25

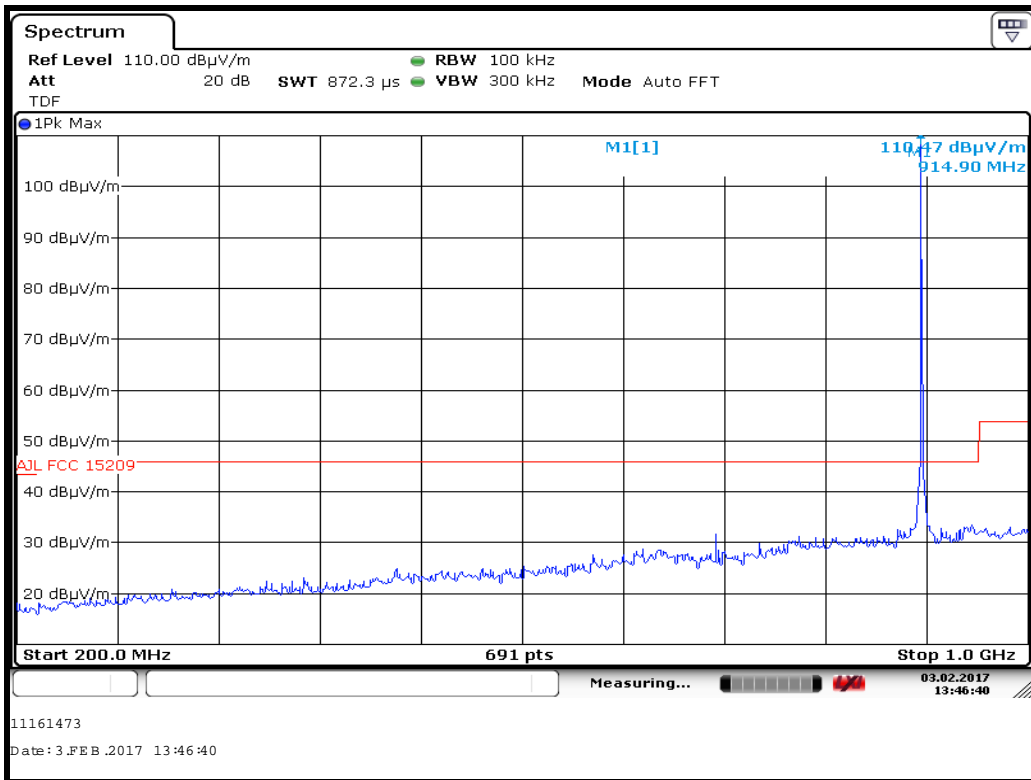
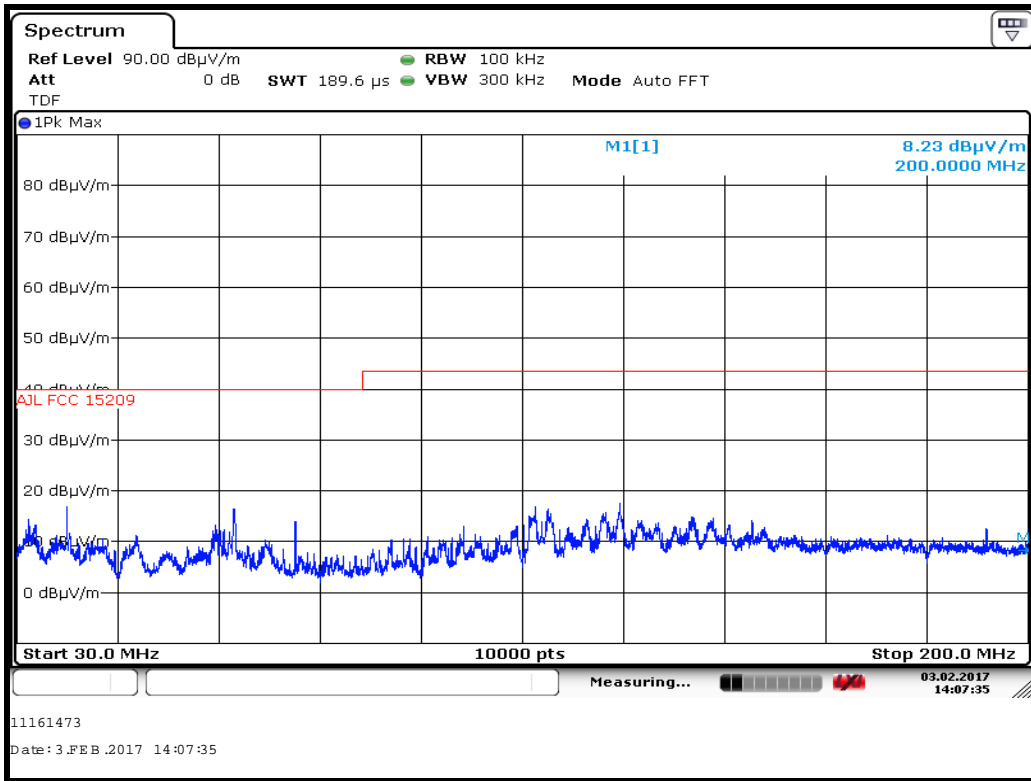

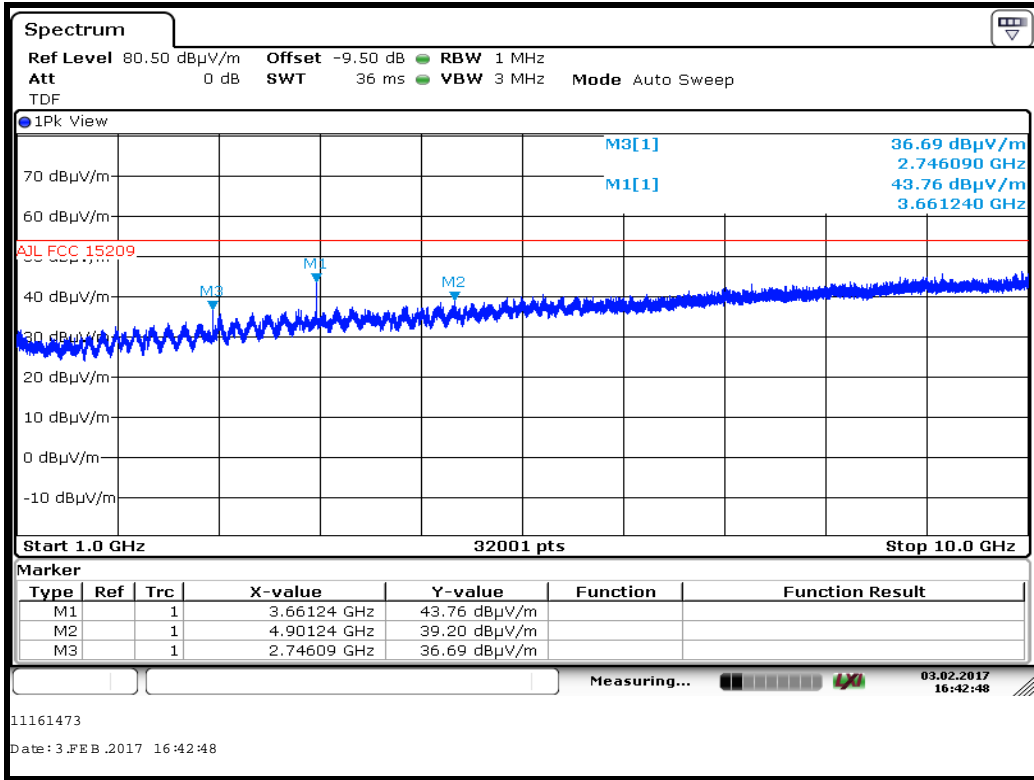

Channel 29 : 921.00

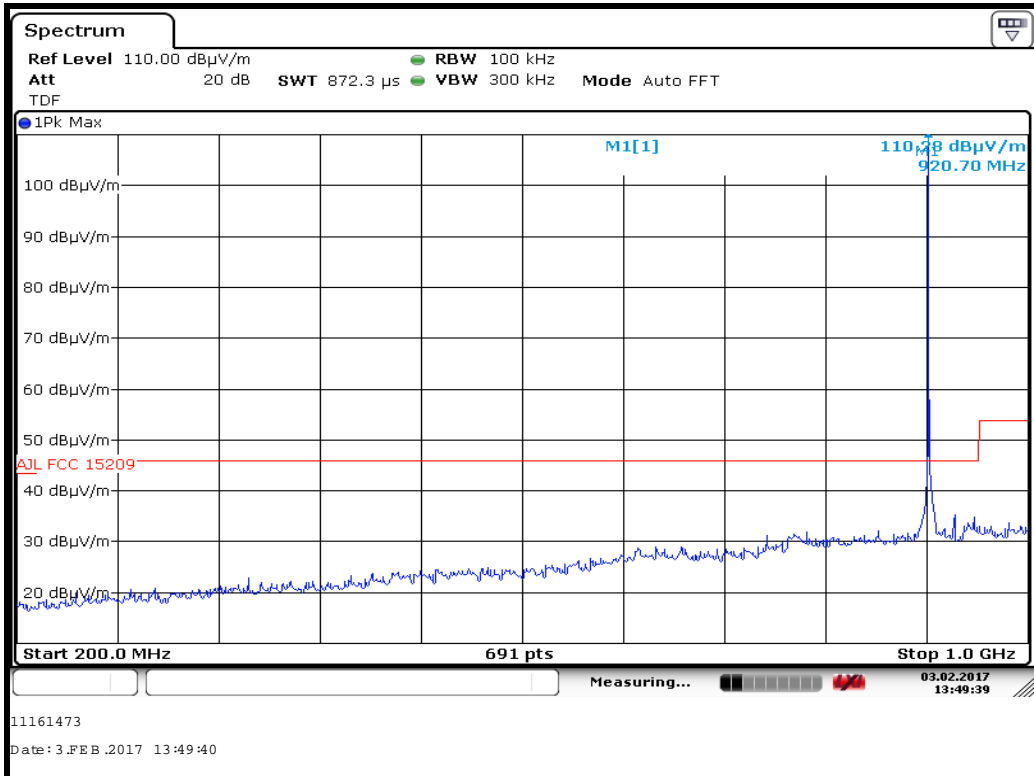
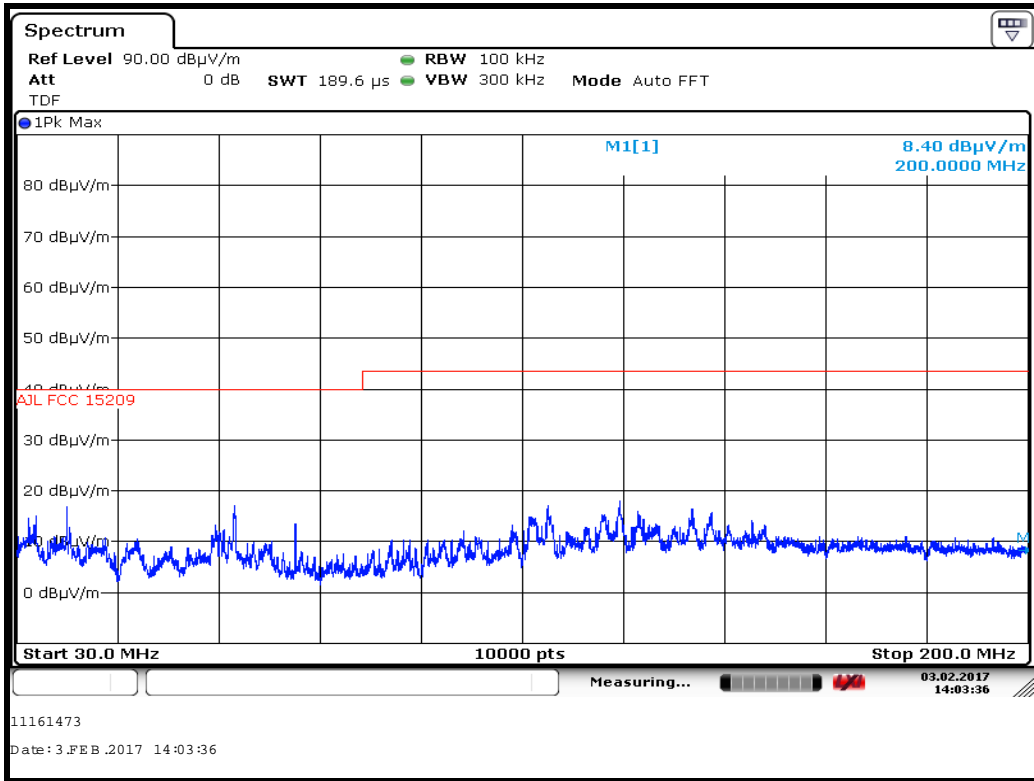

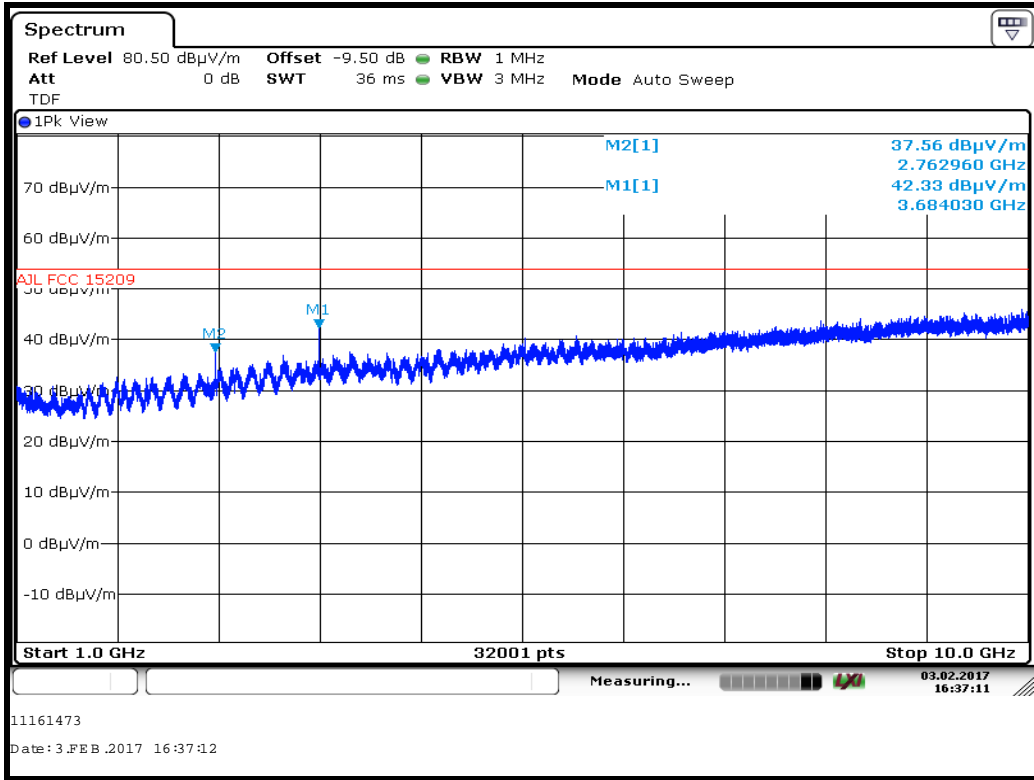

Channel 55 : 927.50

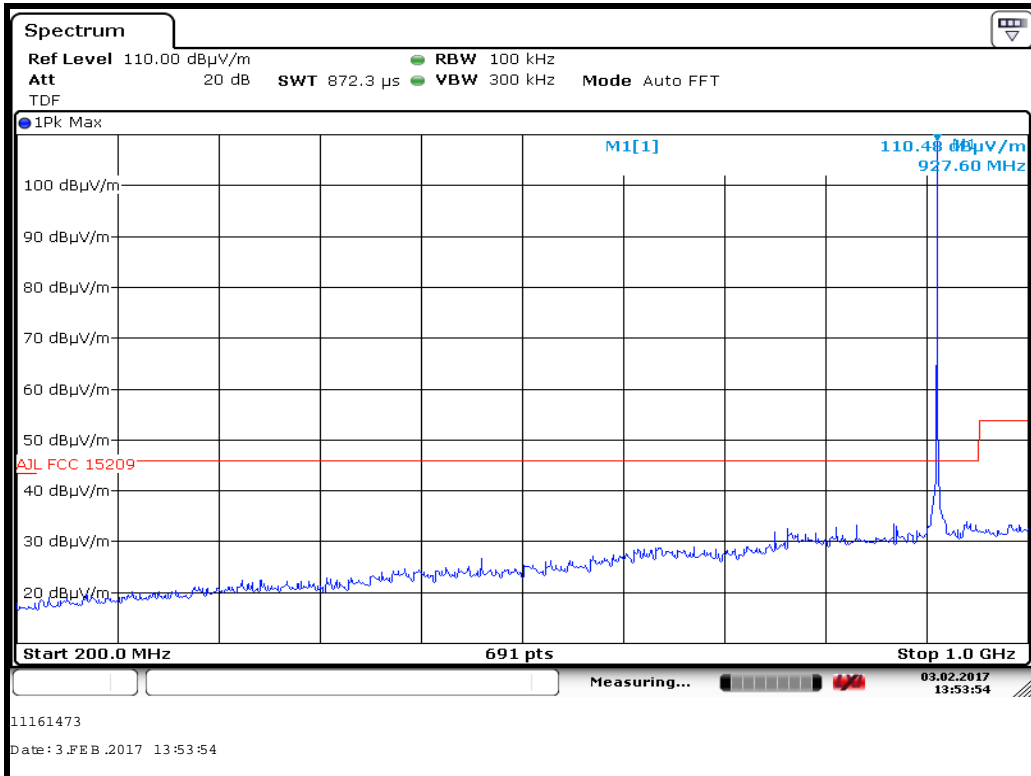
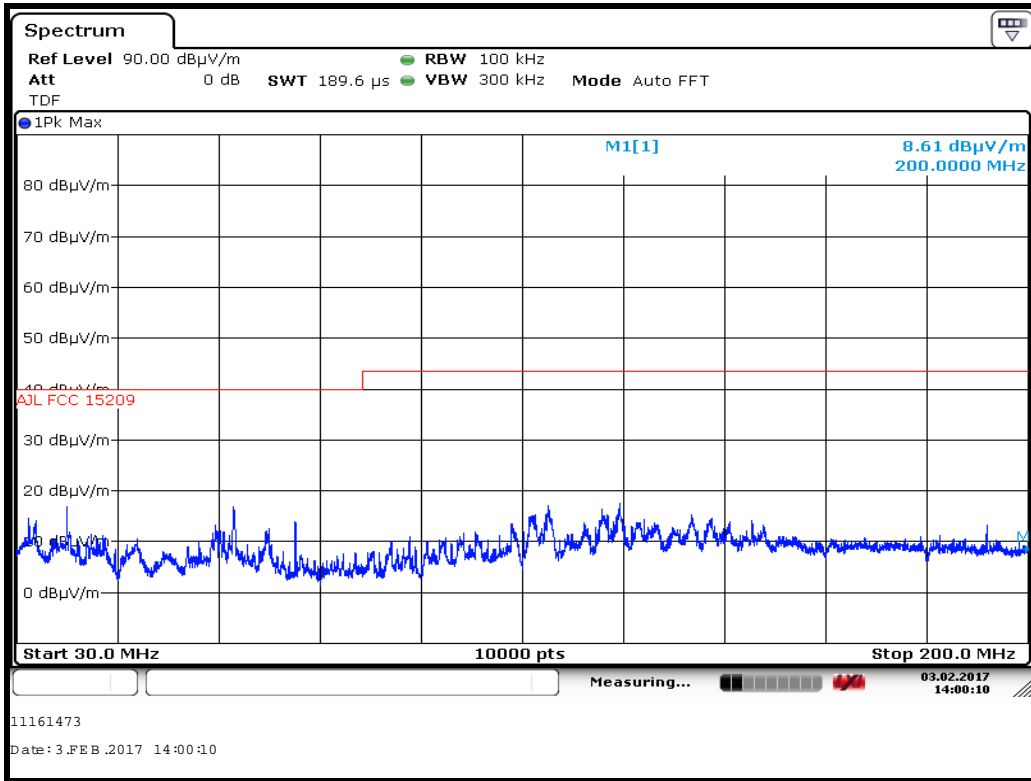

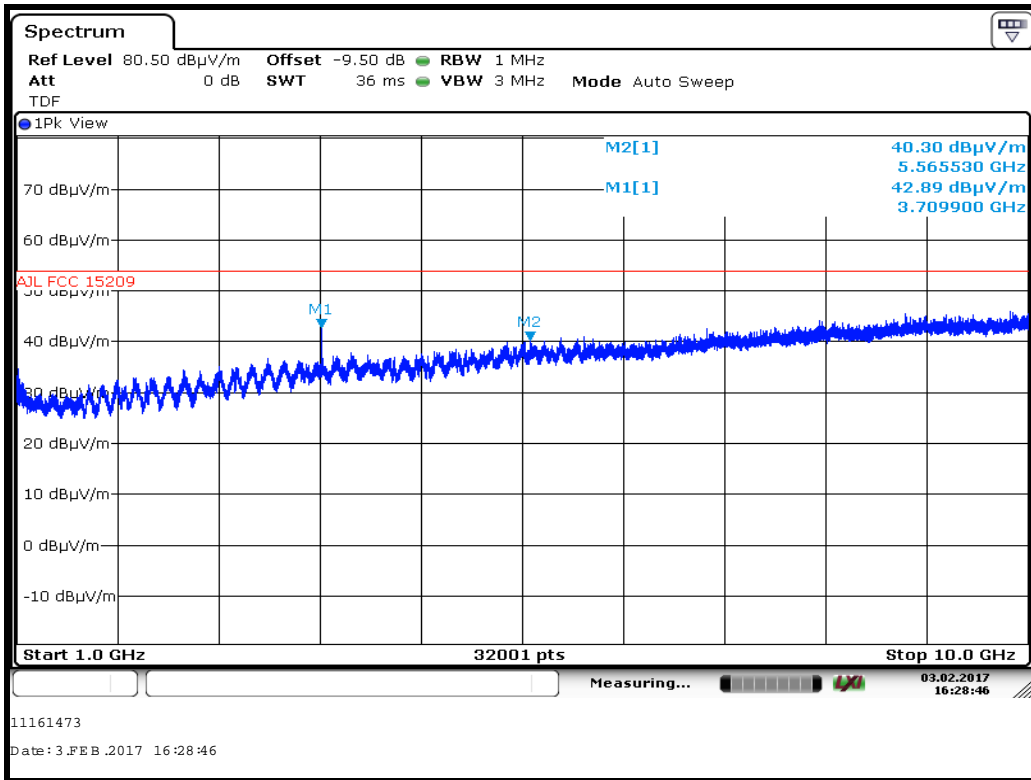

High Power; Channel: 915.25 MHz										
Detector	Freq. (MHz)	Meas'd Emission (dBμV)	Cable Loss (dB)	Antenna Factor (dB/m)	Pre-amp Gain (dB)	Duty Cycle Corr'n (dB)	Distance Extrap'n Factor (dB)	Field Strength (dBμV/m)	Field Strength (μV/m)	Limit (μV/m)
QP	120.02	47.00	1.2	11.9	32.5	0	0	27.6	23.99	150
QP	336.06	38.10	2.0	13.7	32.4	0	0	21.4	11.75	200
QP	960.11	32.80	3.3	21.9	31.3	0	0	26.7	21.63	500
Pk	2745.66	53.13	3.8	29.3	35.3	0.0	-9.5	41.37	117.08	5000
Av	2745.66	47.61	3.8	29.3	35.3	0.0	-9.5	35.85	62.02	500
Pk	3660.98	54.38	4.6	31.6	35.4	0.0	-9.5	45.68	192.31	5000
Av	3660.98	50.13	4.6	31.6	35.4	0.0	-9.5	41.43	117.90	500

High Power; Channel: 921.00 MHz										
Detector	Freq. (MHz)	Meas'd Emission (dBμV)	Cable Loss (dB)	Antenna Factor (dB/m)	Pre-amp Gain (dB)	Duty Cycle Corr'n (dB)	Distance Extrap'n Factor (dB)	Field Strength (dBμV/m)	Field Strength (μV/m)	Limit (μV/m)
QP	120.02	47.00	1.2	11.9	32.5	0	0	27.6	23.99	150
QP	336.06	38.10	2.0	13.7	32.4	0	0	21.4	11.75	200
QP	960.11	32.80	3.3	21.9	31.3	0	0	26.7	21.63	500
Pk	2762.96	53.58	4.2	29.4	35.3	0.0	-9.5	42.31	130.47	5000
Av	2762.96	48.47	4.2	29.4	35.3	0.0	-9.5	37.20	72.44	500
Pk	3684.03	54.91	4.6	31.6	35.4	0.0	-9.5	46.21	204.41	5000
Av	3684.03	51.19	4.6	31.6	35.4	0.0	-9.5	42.49	133.20	500

High Power; Channel: 927.50 MHz										
Detector	Freq. (MHz)	Meas'd Emission (dBμV)	Cable Loss (dB)	Antenna Factor (dB/m)	Pre-amp Gain (dB)	Duty Cycle Corr'n (dB)	Distance Extrap'n Factor (dB)	Field Strength (dBμV/m)	Field Strength (μV/m)	Limit (μV/m)
QP	120.02	47.00	1.2	11.9	32.5	0	0	27.6	23.99	150
QP	336.06	38.10	2.0	13.7	32.4	0	0	21.4	11.75	200
QP	960.11	32.80	3.3	21.9	31.3	0	0	26.7	21.63	500
Pk	3709.90	54.32	4.6	31.7	35.4	0	-9.5	45.72	193.20	5000
Av	3709.90	50.56	4.6	31.7	35.4	0	-9.5	41.96	125.31	500

11.8 Test Results – Mouse Radar

Channel 6 : 915.25

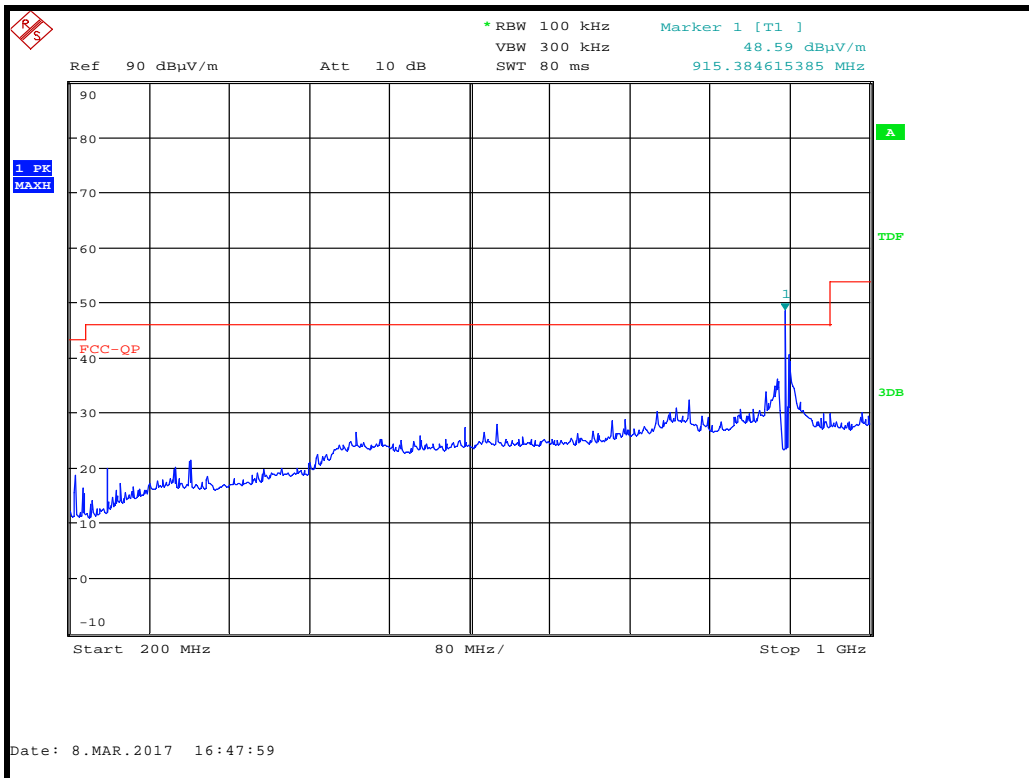
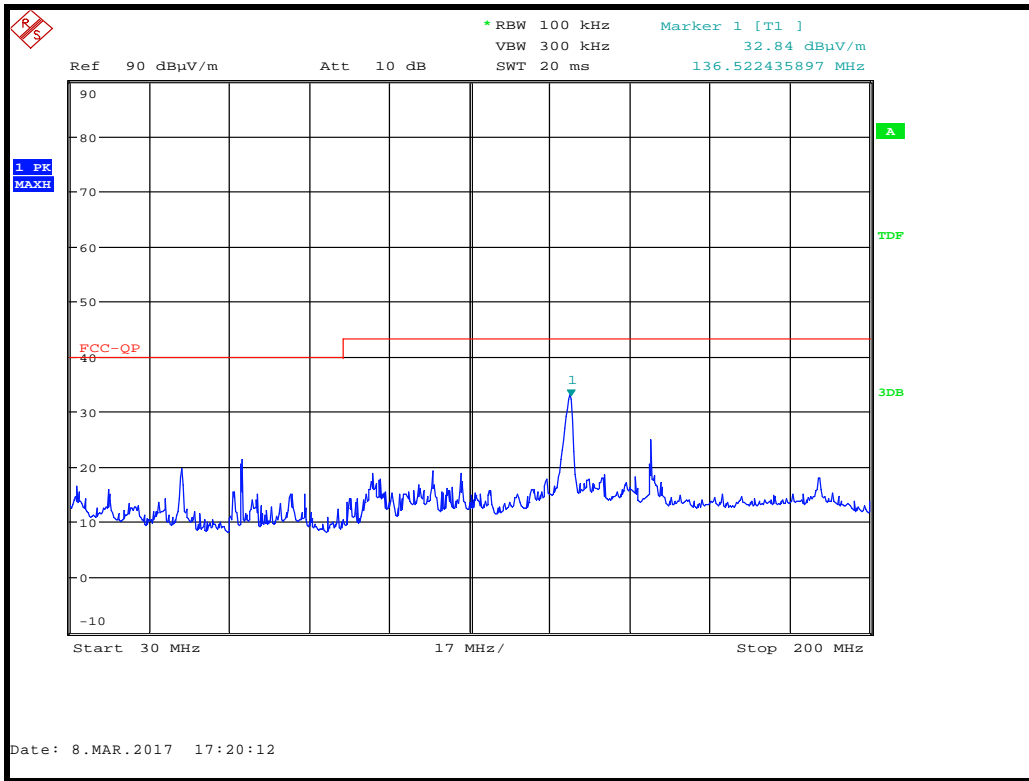

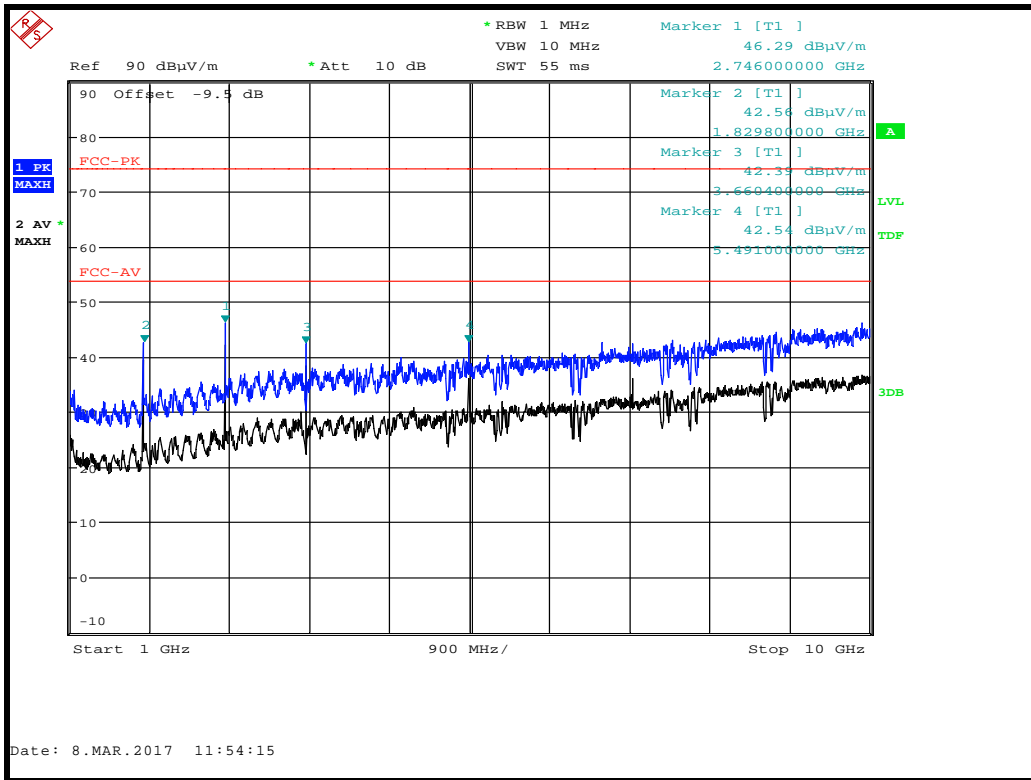

Channel 29 : 921.00

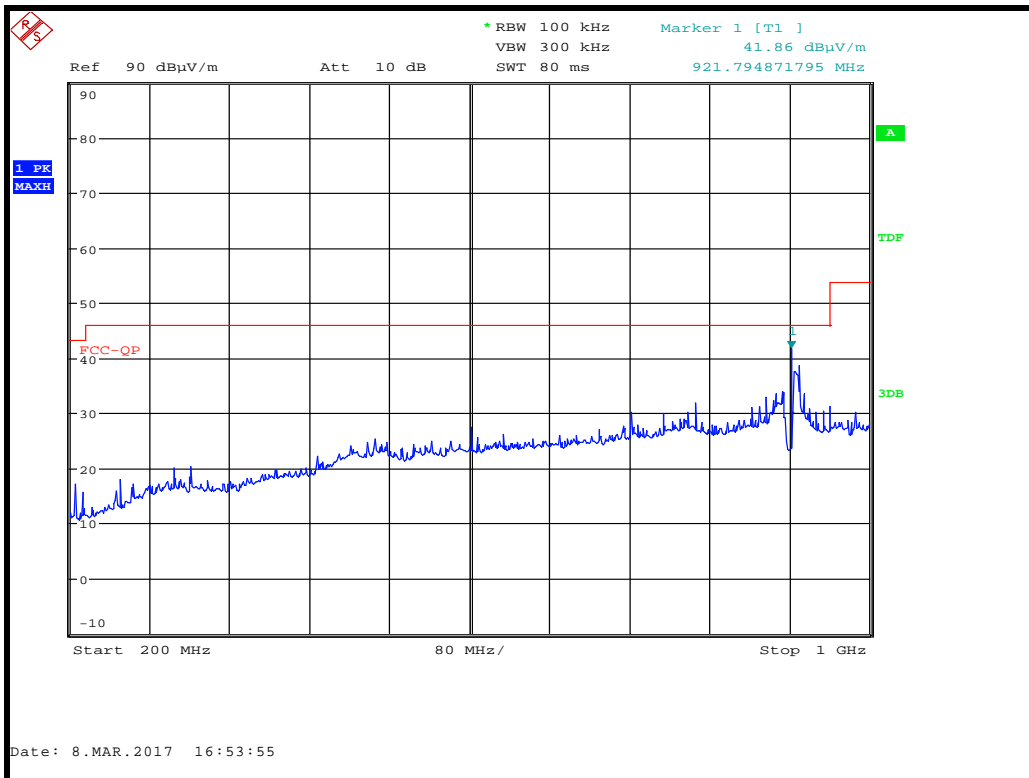
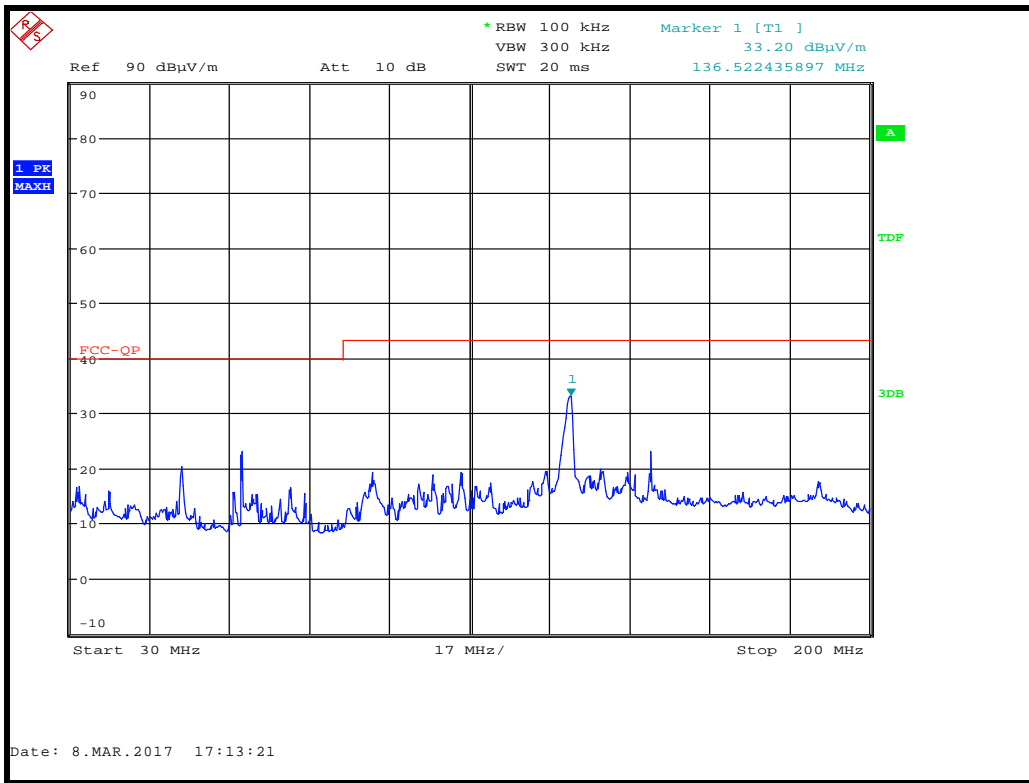

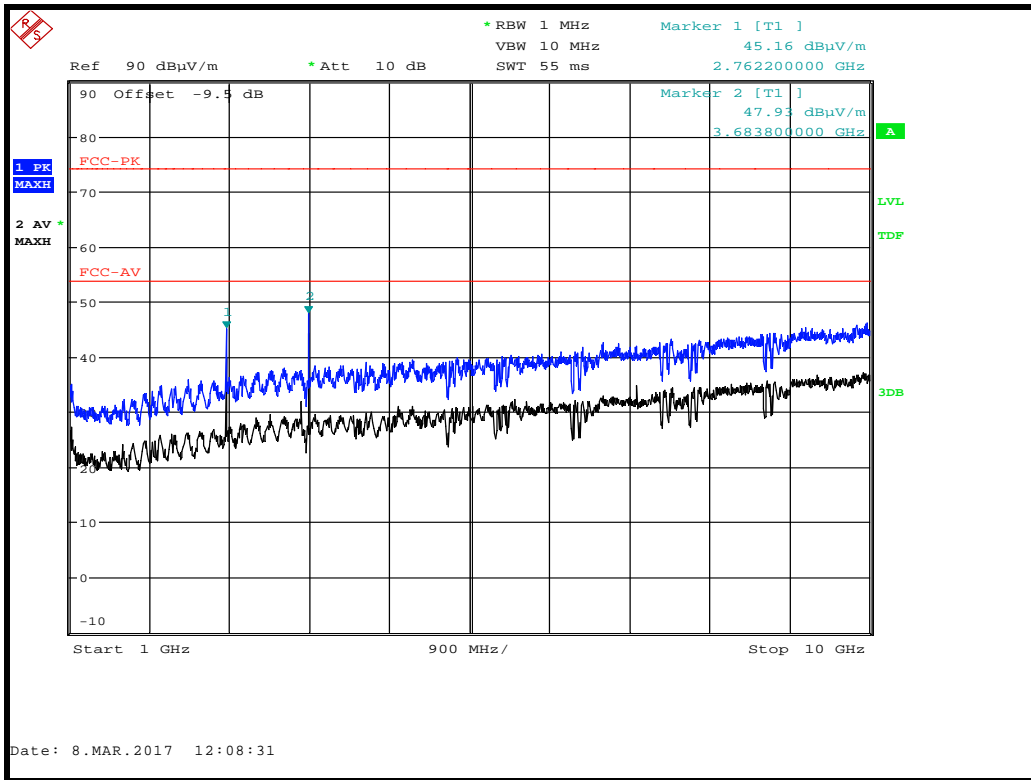

Channel 55 : 927.50

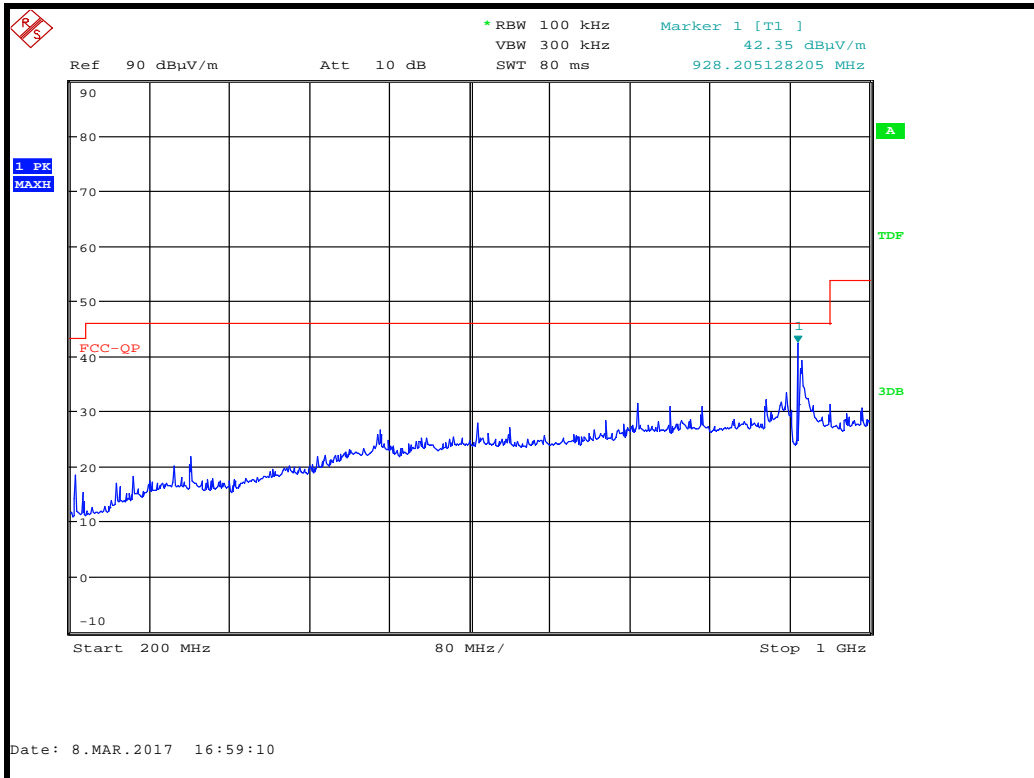
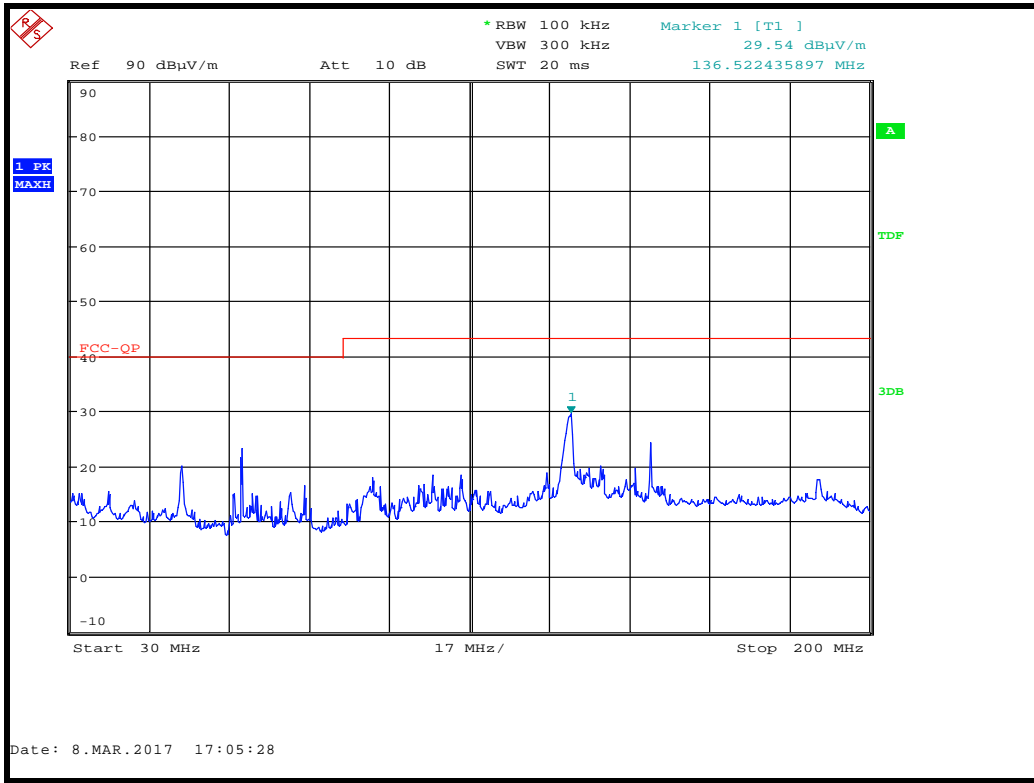

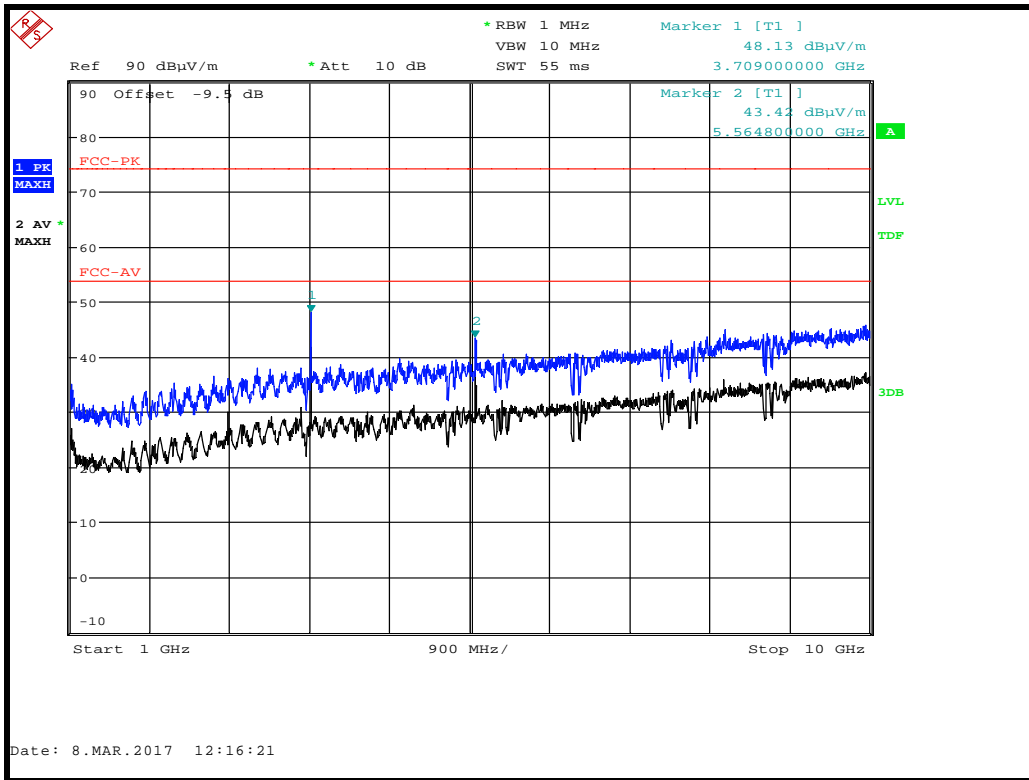

High Power; Channel: 915.25 MHz										
Detector	Freq. (MHz)	Meas'd Emission (dBμV)	Cable Loss (dB)	Antenna Factor (dB/m)	Pre-amp Gain (dB)	Duty Cycle Corr'n (dB)	Distance Extrap'n Factor (dB)	Field Strength (dBμV/m)	Field Strength (μV/m)	Limit (μV/m)
QP	136.52	46.30	1.3	12.7	32.5	0	0	27.8	24.55	150
Pk	2745.81	57.56	3.8	29.3	35.3	0	-9.5	45.80	194.98	5000
Av	2745.81	55.40	3.8	29.3	35.3	0	-9.5	43.64	152.05	500

High Power; Channel: 921.00 MHz										
Detector	Freq. (MHz)	Meas'd Emission (dBμV)	Cable Loss (dB)	Antenna Factor (dB/m)	Pre-amp Gain (dB)	Duty Cycle Corr'n (dB)	Distance Extrap'n Factor (dB)	Field Strength (dBμV/m)	Field Strength (μV/m)	Limit (μV/m)
QP	136.52	46.30	1.3	12.7	32.5	0	0	27.8	24.55	150
Pk	2763.01	57.43	4.2	29.4	35.3	0	-9.5	46.16	203.24	5000
Av	2763.01	55.01	4.2	29.4	35.3	0	-9.5	43.74	153.82	500
Pk	3684.02	57.18	4.6	31.6	35.4	0	-9.5	48.48	265.46	5000
Av	3684.02	54.78	4.6	31.6	35.4	0	-9.5	46.08	201.37	500

High Power; Channel: 927.50 MHz										
Detector	Freq. (MHz)	Meas'd Emission (dBμV)	Cable Loss (dB)	Antenna Factor (dB/m)	Pre-amp Gain (dB)	Duty Cycle Corr'n (dB)	Distance Extrap'n Factor (dB)	Field Strength (dBμV/m)	Field Strength (μV/m)	Limit (μV/m)
QP	136.52	46.30	1.3	12.7	32.5	0	0	27.8	24.55	150
Pk	3710.02	56.52	4.6	31.7	35.4	0	-9.5	47.92	248.89	5000
Av	3710.02	54.19	4.6	31.7	35.4	0	-9.5	45.59	190.33	500

12 AC power-line conducted emissions

12.1 Definition

Line-to-ground radio-noise voltage that is conducted from all of the EUT current-carrying power input terminals that are directly (or indirectly via separate transformers or power supplies) connected to a public power network.

12.2 Test Parameters

Test Location:	Element Hull
Test Chamber:	Lab 5
Test Standard and Clause:	ANSI C63.10-2013, Clause 6.2
EUT Channels / Frequencies Measured:	Mid
EUT Modulation:	LoRa and GSM active
Deviations From Standard:	None
Measurement BW:	9 kHz
Measurement Detectors:	Quasi-Peak and Average, RMS

Environmental Conditions (Normal Environment)

Temperature: 21 °C	+15 °C to +35 °C (as declared)
Humidity: 34 % RH	20 % RH to 75 % RH (as declared)
Supply: 110 V dc	

Test Limit

A radio apparatus that is designed to be connected to the public utility (AC) power line shall ensure that the radio frequency voltage, which is conducted back onto the AC power line on any frequency or frequencies within the band 150 kHz to 30 MHz, shall not exceed the limits in Table 3.

Table 3 – AC Power Line Conducted Emission Limits

Frequency (MHz)	Conducted limit (dB μ V)	
	Quasi-Peak	Average**
0.15 to 0.5	66 to 56*	56 to 46*
0.5 to 5	56	46
5 to 30	60	50

*The level decreases linearly with the logarithm of the frequency.

**A linear average detector is required.

12.3 Test Method

With the EUT setup in a screened room, as per section 9 of this report and connected as per Figure ii, the power line emissions were measured on a spectrum analyzer / EMI receiver.

AC power line conducted emissions from the EUT are checked first by preview scans with peak and average detectors covering both live and neutral lines. A spectrum analyzer is used to determine if any periodic emissions are present.

Formal measurements using the correct detector(s) and bandwidth are made on frequencies identified from the preview scans. Final measurements were performed with EUT set at its maximum duty in transmit and receive modes.

Figure ii Test Setup

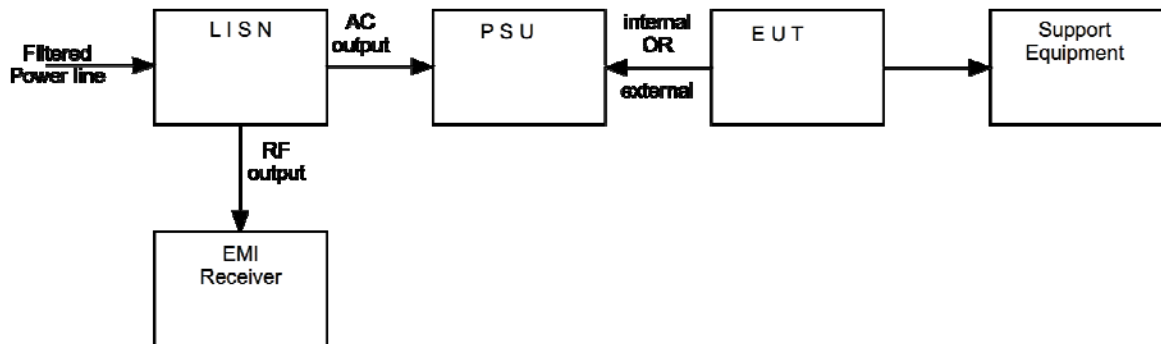

12.4 Test Set-up Photograph



12.5 Test Equipment

Equipment Type	Manufacturer	Equipment Description	Element No	Due For Calibration
ESH3-Z2	R&S	Pulse Limiter	RFG680	14/06/2017
ESH3-Z5	R&S	LISN	RFG189	02/08/2017
ESC17	R&S	Measuring Receiver	RFG715	06/10/2017

12.6 Test Results

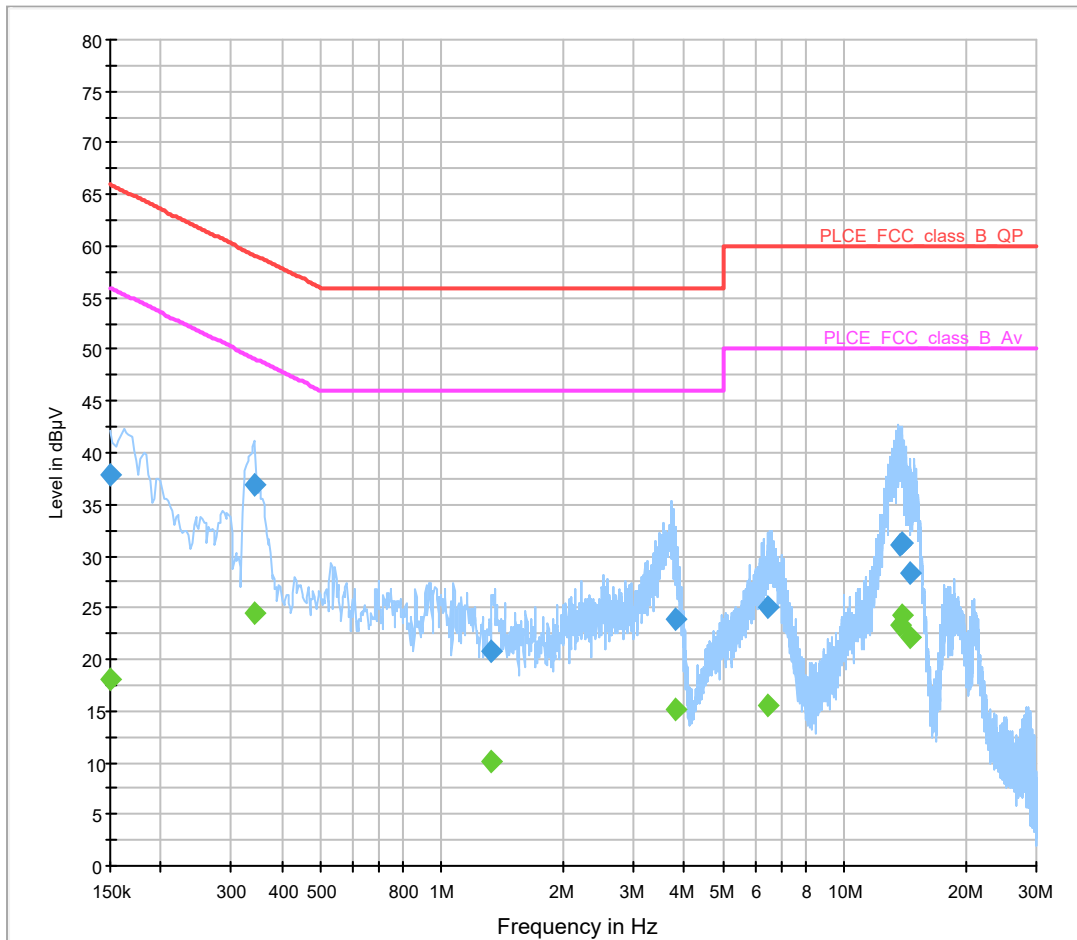

Frequency (MHz)	QuasiPeak (dBµV)	Meas. Time (ms)	Bandwidth (kHz)	PE	Line	Corr. (dB)	Margin (dB)	Limit (dBµV)
0.150000	37.8	15000.0	0.200	GND	N	0.2	28.2	66.0
0.340650	36.9	15000.0	9.000	GND	L1	0.3	22.3	59.2
1.320600	20.8	15000.0	9.000	GND	N	0.3	35.2	56.0
3.796400	23.8	15000.0	9.000	GND	N	0.4	32.2	56.0
6.470000	25.1	15000.0	9.000	GND	N	0.5	34.9	60.0
13.781500	31.1	15000.0	9.000	GND	L1	1.3	28.9	60.0
13.977500	31.4	15000.0	9.000	GND	L1	1.4	28.6	60.0
14.579000	28.4	15000.0	9.000	GND	L1	1.4	31.6	60.0

Frequency (MHz)	Average (dBµV)	Meas. Time (ms)	Bandwidth (kHz)	PE	Line	Corr. (dB)	Margin (dB)	Limit (dBµV)
0.150000	18.1	15000.0	9.000	GND	N	0.2	37.9	56.0
0.340650	24.4	15000.0	9.000	GND	L1	0.3	24.8	49.2
1.320600	10.1	15000.0	9.000	GND	N	0.3	35.9	46.0
3.796400	15.1	15000.0	9.000	GND	N	0.4	30.9	46.0
6.470000	15.5	15000.0	9.000	GND	N	0.5	34.5	50.0
13.781500	23.3	15000.0	9.000	GND	L1	1.3	26.7	50.0
13.977500	24.2	15000.0	9.000	GND	L1	1.4	25.8	50.0
14.579000	22.2	15000.0	9.000	GND	L1	1.4	27.8	50.0

13 Carrier frequency separation

13.1 Definition

The carrier frequency separation is the frequency separation between two adjacent hopping frequencies.

13.2 Test Parameters

Test Location:	Element Hull
Test Chamber:	Lab 4
Test Standard and Clause:	ANSI C63.10-2013, Clause 7.8.2
EUT Channels / Frequencies Measured:	All; 2405 to 2480 MHz
EUT 20dB Bandwidth:	148 kHz
EUT Test Modulations:	Internal pattern generation – hopping enabled
Deviations From Standard:	None
Measurement BW:	4.3 kHz
Measurement Detector:	Peak

Environmental Conditions (Normal Environment)

Temperature: 22 °C	+15 °C to +35 °C (as declared)
Humidity: 33 % RH	20 % RH to 75 % RH (as declared)
Supply: 6 V dc	

13.3 Test Limit

Frequency hopping systems shall have hopping channel carrier frequencies separated by a minimum of 25 kHz or the -20 dB bandwidth of the hopping channel, whichever is greater. Alternatively, frequency hopping systems operating in the band 2400 to 2483.5 MHz may have hopping channel carrier frequencies that are separated by 25 kHz or two-thirds of the -20 dB bandwidth of the hopping channel, whichever is greater, provided that the systems operate with an output power no greater than 0.125 W.

13.4 Test Method

With the EUT setup as per section 9 of this report and connected as per Figure iii, the emissions of the EUT were measured on a spectrum analyser.

The measurements were performed with EUT set at its maximum duty. All modulation schemes, data rates and power settings were used to observe the worst-case configuration in each nominal bandwidth.

Figure iii Test Setup

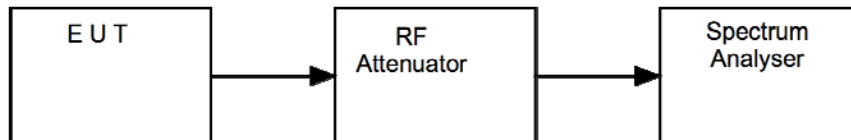

13.5 Test Equipment

Equipment Type	Manufacturer	Equipment Description	Element No	Due For Calibration
N9030A	Agilent	Spectrum Analyser	REF2167	19/04/2018

13.6 Test Results

<i>Channel #: 33 & 34; Modulation: LoRa; Power setting: 0x0F</i>				
<i>Data Rate</i>	<i>F_{1c} (MHz)</i>	<i>F_{2c} (MHz)</i>	<i>Channel Separation, F_{2c} – F_{1c} (kHz)</i>	<i>Result</i>
LoRa	921.93870	922.18980	251.1	PASS

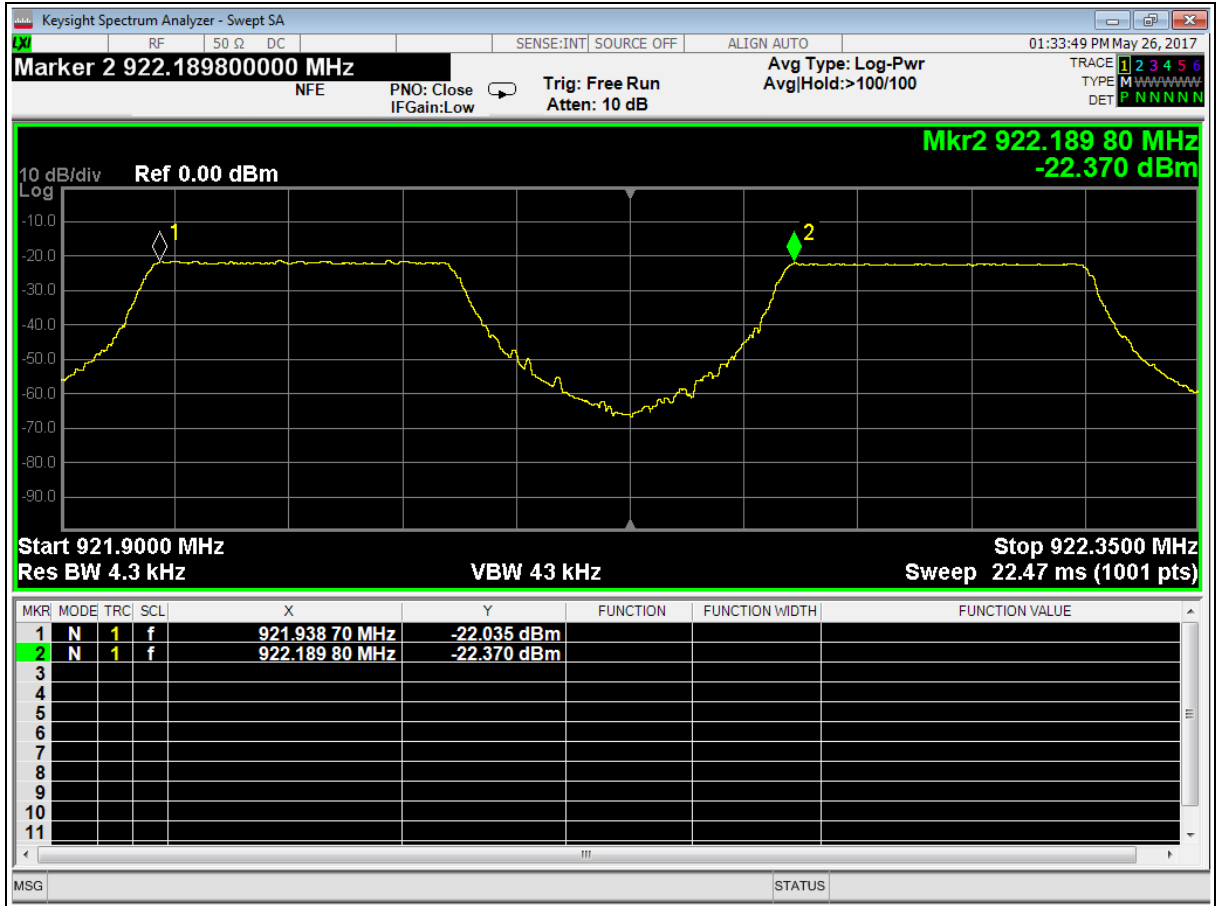

14 Number of hopping frequencies

14.1 Definition

The total number of hopping frequencies (the centre frequencies defined within the hopping sequence of a FHSS equipment) which are randomly sequenced in order to spread the transmission.

14.2 Test Parameters

Test Location:	Element Hull
Test Chamber:	Lab 4
Test Standard and Clause:	ANSI C63.10-2013, Clause 7.8.3
EUT Channels / Frequencies Measured:	All; 2405 – 2480 MHz
EUT 20dB Bandwidth:	148 kHz
EUT Test Modulations:	Internal pattern generation – hopping enabled
Deviations From Standard:	None
Measurement BW:	100 kHz
Measurement Detector:	Peak

Environmental Conditions (Normal Environment)

Temperature: 22 °C	+15 °C to +35 °C (as declared)
Humidity: 33 % RH	20 % RH to 75 % RH (as declared)
Supply: 6 V dc	

14.3 Test Limit

- For frequency hopping systems in the band 902 to 928 MHz: if the -20 dB bandwidth of the hopping channel is less than 250 kHz, the system shall use at least 50 hopping channels;
If the -20 dB bandwidth of the hopping channel is 250 kHz or greater, the system shall use at least 25 hopping channels;
- Frequency hopping systems operating in the band 2400 to 2483.5 MHz shall use at least 15 hopping channels;
- Frequency hopping systems operating in the band 5725 to 5850 MHz shall use at least 75 hopping channels.

14.4 Test Method

With the EUT setup as per section 9 of this report and connected as per Figure iv, the emissions of the EUT were measured on a spectrum analyser.

The measurements were performed with EUT set at its maximum duty. All modulation schemes, data rates and power settings were used to observe the worst-case configuration in each nominal bandwidth.

Figure iv Test Setup

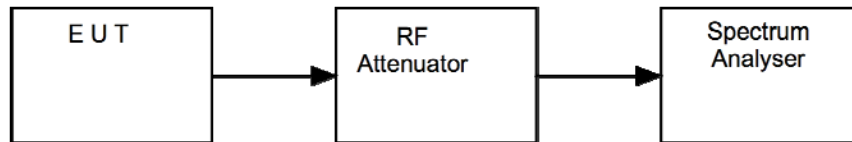

14.5 Test Equipment

Equipment Type	Manufacturer	Equipment Description	Element No	Due For Calibration
N9030A	Agilent	Spectrum Analyser	REF2167	19/04/2018

14.6 Test Results

<i>Modulation: LoRa ; Power setting: .0x0F</i>				
<i>Data Rate</i>	<i>Lowest channel, F_{CL} (MHz)</i>	<i>Highest channel, F_{CH} (MHz)</i>	<i>Number of channels observed</i>	<i>Result</i>
LoRa	915.200	927.500	50	PASS

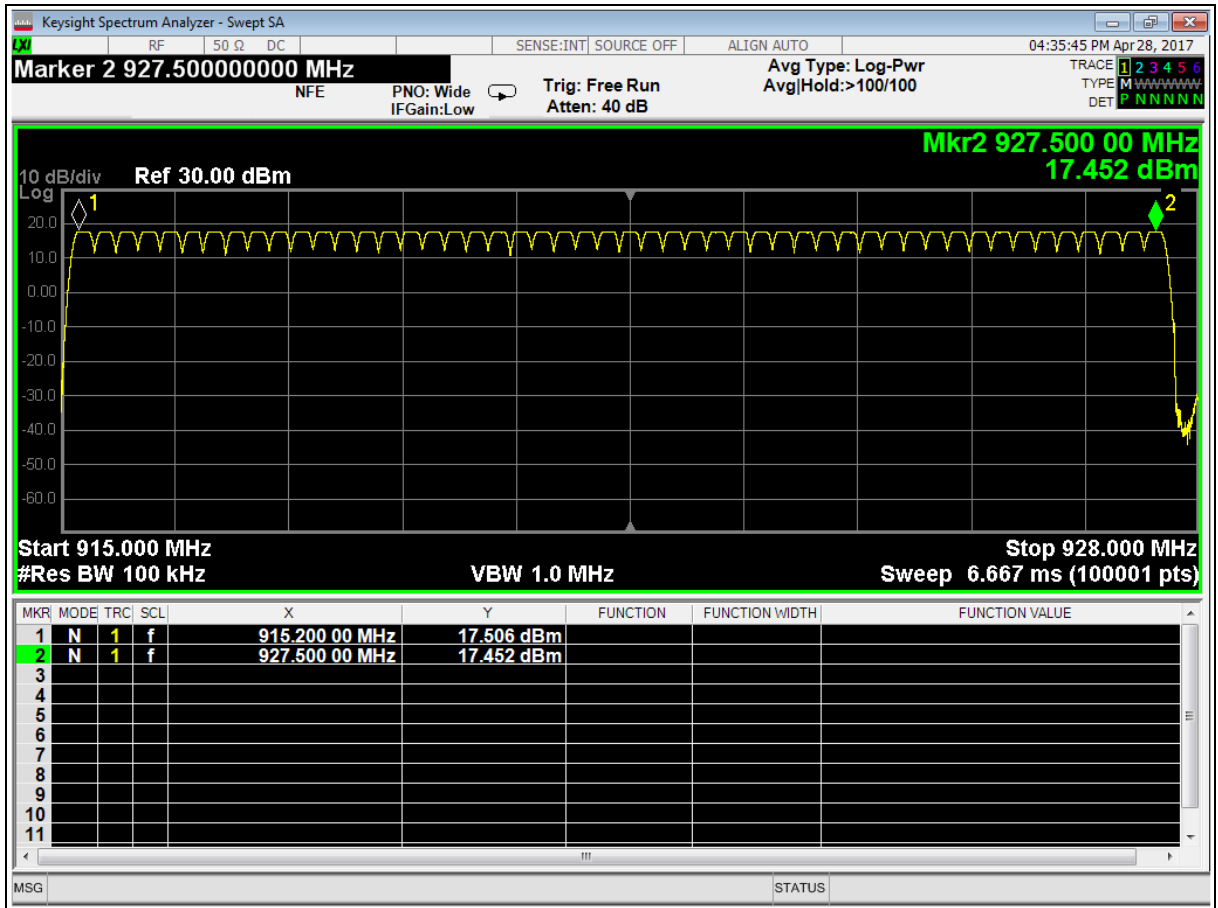

15 Average channel occupancy

15.1 Definition

The channel occupancy is the total of the transmitter 'on' times, during an observation period, on a particular hopping frequency.

15.2 Test Parameters

Test Location:	Element Hull
Test Chamber:	Lab 4
Test Standard and Clause:	ANSI C63.10-2013, Clause 7.8.4
EUT Channels / Frequencies Measured:	Mid
EUT 20dB bandwidth:	148 kHz
EUT Number of hopping channels:	50
EUT Test Modulations:	Internal pattern generation – hopping enabled
Deviations From Standard:	None
Measurement BW:	100 kHz
Measurement Detector:	Peak

Environmental Conditions (Normal Environment)

Temperature: 22 °C	+15 °C to +35 °C (as declared)
Humidity: 33 % RH	20 % RH to 75 % RH (as declared)
Supply: 6 V dc	

15.3 Test Limit

- For frequency hopping systems in the band 902 to 928 MHz: if the -20 dB bandwidth of the hopping channel is less than 250 kHz, the average time of occupancy on any channel shall not be greater than 0.4 seconds within a 20 second period; If the -20 dB bandwidth of the hopping channel is 250 kHz or greater, the average time of occupancy on any channel shall not be greater than 0.4 seconds within a 10 second period;
- Frequency hopping systems operating in the band 2400 to 2483.5 MHz: The average time of occupancy on any channel shall not be greater than 0.4 seconds within a period of 0.4 seconds, multiplied by the number of hopping channels employed;
- Frequency hopping systems operating in the band 5725 to 5850 MHz: The average time of occupancy on any frequency shall not be greater than 0.4 seconds within a 30 second period.

15.4 Test Method

With the EUT setup as per section 9 of this report and connected as per Figure v, the emissions of the EUT were measured on a spectrum analyser.

The measurements were performed with EUT set at its maximum duty. A number of hops were observed to confirm consistency of the dwell time / observe the worst case. All modulation schemes, data rates and power settings were used to observe the worst-case configuration.

Figure v Test Setup

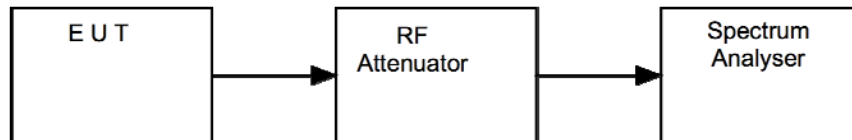

15.5 Test Equipment

Equipment Type	Manufacturer	Equipment Description	Element No	Due For Calibration
N9030A	Agilent	Spectrum Analyser	REF2167	19/04/2018

15.6 Test Results

<i>Modulation: LoRa; Power setting: .0x0F</i>					
<i>Data Rate</i>	<i>Individual occupancy time (s)</i>	<i>Observation period (s)</i>	<i>Number of hops observed</i>	<i>Average time of occupancy (s)</i>	<i>Result</i>
LoRa	0.052	20	2	0.104	PASS

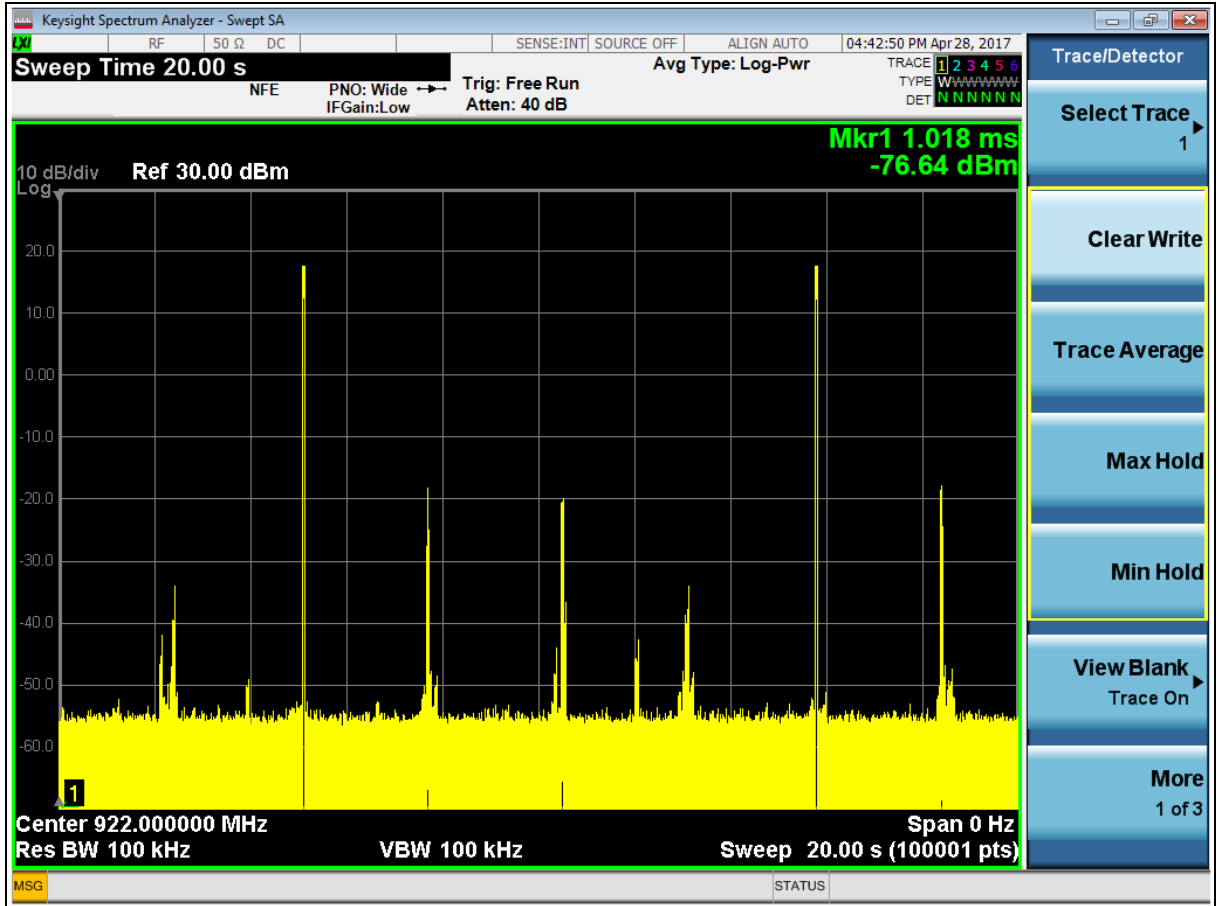

16 Maximum peak conducted output power

16.1 Definition

The maximum peak conducted output power is defined as the maximum power level measured with a peak detector using a filter with width and shape of which is sufficient to accept the signal bandwidth.

16.2 Test Parameters

Test Location:	Element Hull
Test Chamber:	Lab 4
Test Standard and Clause:	ANSI C63.10-2013, Clause 7.8.5
EUT Channels / Frequencies Measured:	Low / Mid / High – hopping disabled.
EUT Channel Bandwidths:	200 kHz
Deviations From Standard:	None
Measurement BW:	3 kHz
Spectrum Analyzer Video BW:	10 kHz
Measurement Detector:	Peak
Voltage Extreme Environment Test Range:	Mains Power = 85 % and 115 % of Nominal (FCC only requirement); Battery Power = new battery.

Environmental Conditions (Normal Environment)

Temperature: 22 °C	+15 °C to +35 °C (as declared)
Humidity: 33 % RH	20 % RH to 75 % RH (as declared)

16.3 Test Limit

- For frequency hopping systems operating in the band 902 to 928 MHz, the maximum peak conducted output power shall not exceed 1 W, and the e.i.r.p. shall not exceed 4 W, if the hopset uses 50 or more hopping channels; the maximum peak conducted output power shall not exceed 0.25 W, and the e.i.r.p. shall not exceed 1 W, if the hopset uses less than 50 hopping channels.
- For frequency hopping systems operating in the band 2400 to 2483.5 MHz and employing at least 75 hopping channels, the maximum peak conducted output power shall not exceed 1 W; for all other frequency hopping systems in the band, the maximum peak conducted output power shall not exceed 0.125 W. The e.i.r.p. shall not exceed 4 W.
- For frequency hopping systems operating in the band 5725 to 5850 MHz, the maximum peak conducted output power shall not exceed 1 W. The e.i.r.p. shall not exceed 4 W.
- Point-to-point systems in the bands 2400-2483.5 MHz and 5725 to 5850 MHz are permitted to have an e.i.r.p. higher than 4 W provided that the higher e.i.r.p. is achieved by employing higher gain directional antennas and not higher transmitter output powers.

16.4 Test Method

With the EUT setup as per section 9 of this report and connected as per Figure vi, the resolution bandwidth of the spectrum analyser was increased above the EUT occupied bandwidth and the peak emission data noted.

The measurements were performed with EUT set at its maximum duty. All modulation schemes, data rates and power settings were used to observe the worst-case configuration in each bandwidth.

Figure vi Test Setup

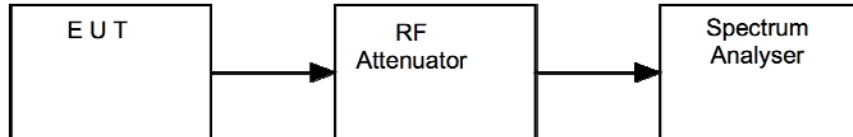

16.5 Test Equipment

Equipment Type	Manufacturer	Equipment Description	Element No	Due For Calibration
FSV	Rohde & Schwarz	Spectrum Analyser	N/A	07/06/2017

16.6 Test Results

Modulation: LoRa; Data rate: LoRa; Power setting: 0x0F						
Channel Frequency (MHz)	Analyzer Level (dBm)	Cable loss (dB)	Maximum peak conducted output power (W)	Antenna gain (dBi)	E.I.R.P. (W)	Result
915.25	22.56	0	0.180302	6 (max)	0.717794	PASS
921.00	21.75	0	0.149624	6 (max)	0.595662	PASS
927.50	21.90	0	0.154882	6 (max)	0.616595	PASS

Antennas used by all three products covered by this report were < 6 dBi gain, 6 dBi was used as a worst case to cover all products.

Measurements were made using the AVGSA-1 method detailed in 558074 D01 DTS Meas Guidance v04

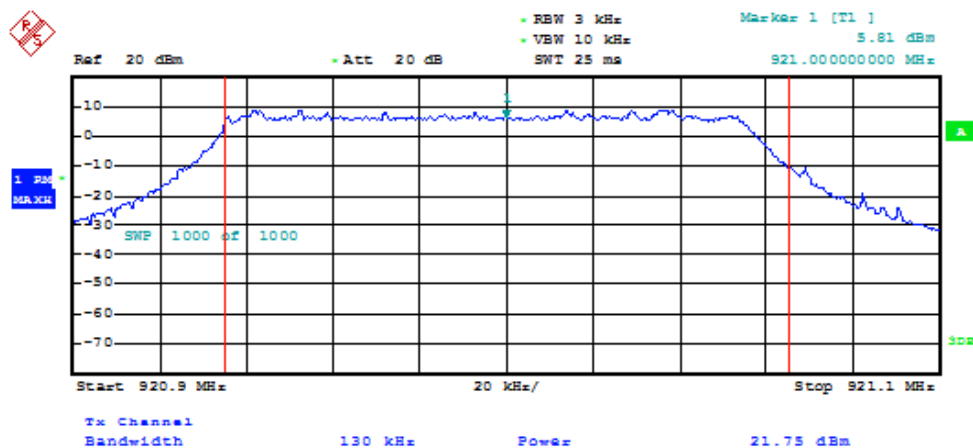
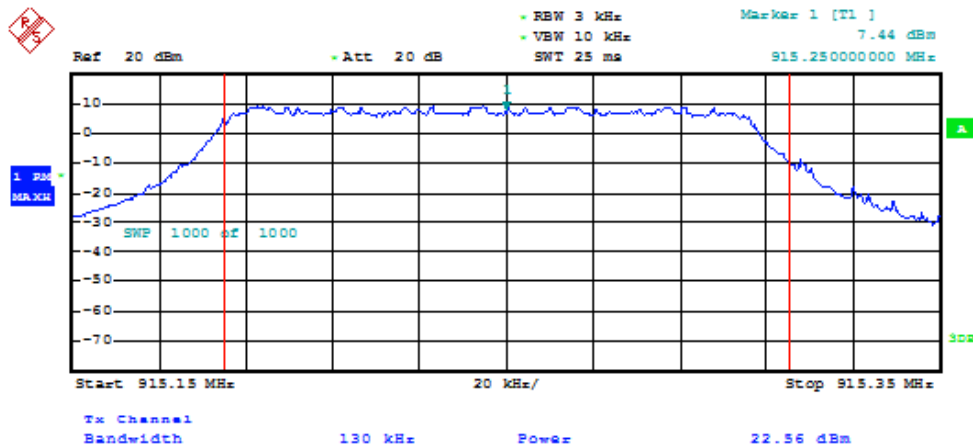

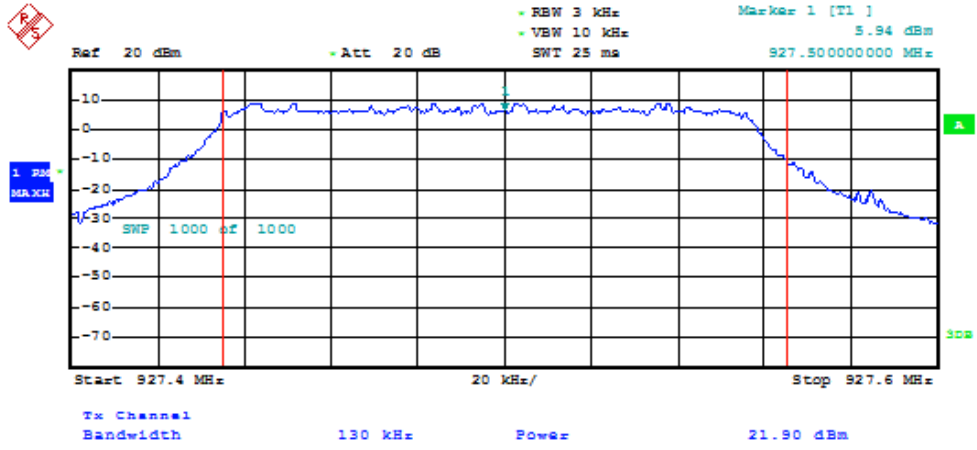

17 Occupied Bandwidth

17.1 Definition

The emission bandwidth (x dB) is defined as the frequency range between two points, one above and one below the carrier frequency, at which the spectral density of the emission is attenuated x dB below the maximum in-band spectral density of the modulated signal.

17.2 Test Parameters

Test Location:	Element Hull
Test Chamber:	Lab 4
Test Standard and Clause:	ANSI C63.10-2013, Clause 6.9
EUT Channels / Frequencies Measured:	Low / Mid / High – hopping stopped.
EUT Channel Bandwidths:	
EUT Test Modulations:	LoRa
Deviations From Standard:	None
Measurement BW: (requirement: 1 % to 5 % OBW)	100 kHz (DSSS), 4.7 (FHSS)
Spectrum Analyzer Video BW: (requirement at least 3x RBW)	, 47 (FHSS)
Measurement Span: (requirement 2 to 5 times OBW)	1 MHz
Measurement Detector:	Peak

Environmental Conditions (Normal Environment)

Temperature: 21 °C	+15 °C to +35 °C (as declared)
Humidity: 32 % RH	20 % RH to 75 % RH (as declared)
Supply: 6 V dc	

17.3 Test Limit

- For frequency hopping systems in the band 902 to 928 MHz: The maximum allowed -20 dB bandwidth of the hopping channel is 500 kHz.
- Frequency hopping systems operating in the band 5725 to 5850 MHz: The maximum -20 dB bandwidth of the hopping channel shall be 1 MHz

17.4 Test Method

With the EUT setup as per section 9 of this report and connected as per Figure vii, the bandwidth of the EUT was measured on a spectrum analyser.

The measurements were performed with EUT set at its maximum duty. All modulation schemes, data rates and power settings were used to observe the worst-case configuration in each bandwidth.

Figure vii Test Setup

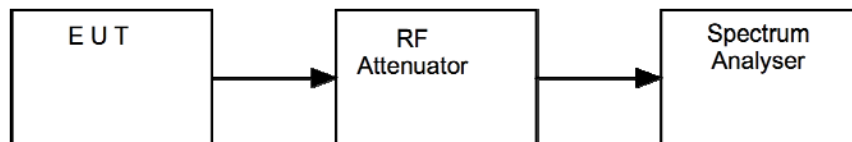

17.5 Test Equipment

Equipment Type	Manufacturer	Equipment Description	Element No	Due For Calibration
E4440A	Agilent	Spectrum Analyser	REF837	22/06/2017

17.6 Test Results

Hybrid: FHSS requirement			
Modulation: LoRa; Data rate: LoRa; Power setting: 0x0F			
Channel Frequency (MHz)	99% Bandwidth (kHz)	20dB Bandwidth (kHz)	Result
915.25	128.5071	148.1840	PASS
921.00	128.1051	145.9190	PASS
927.50	127.9303	146.636	PASS

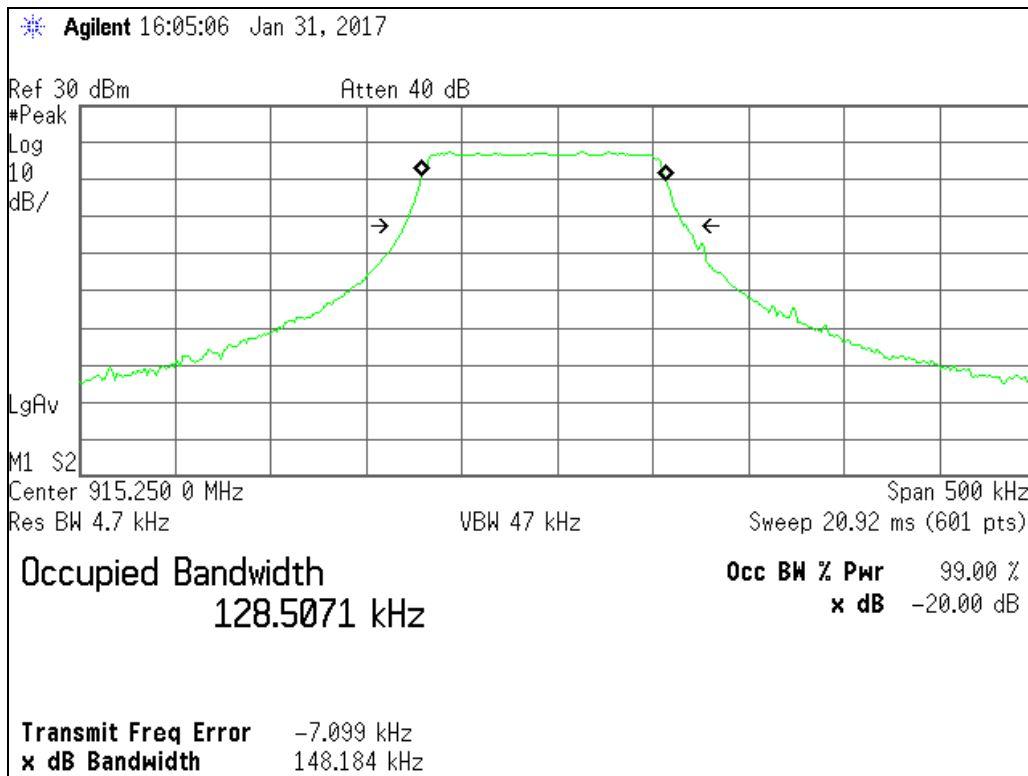

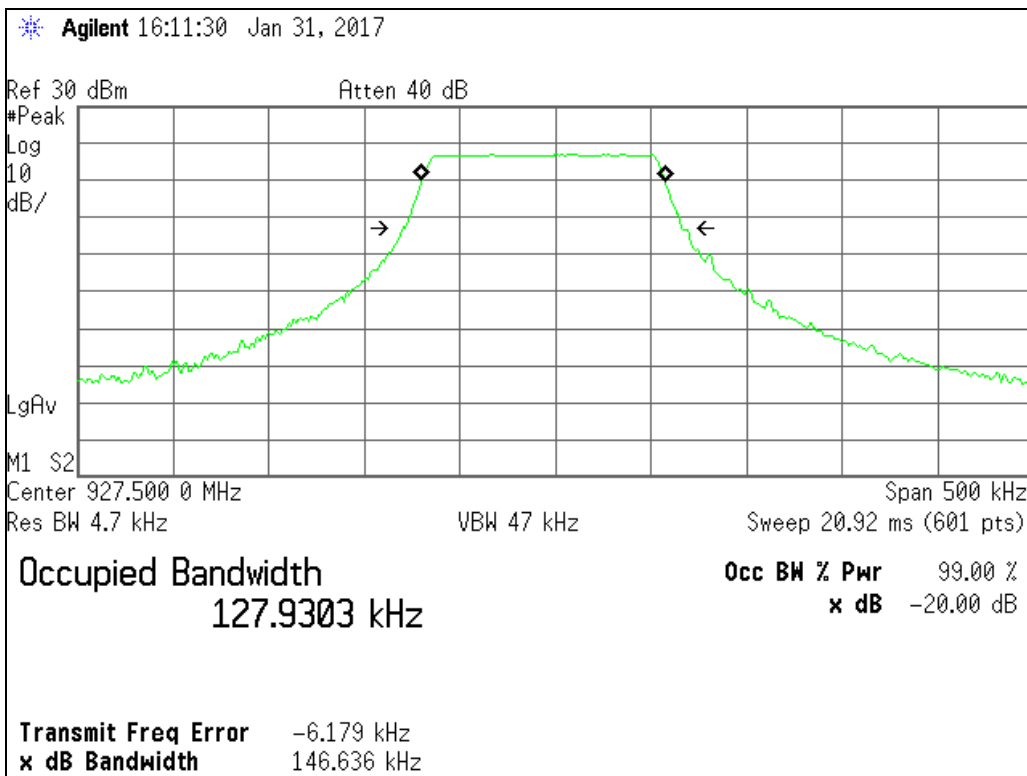
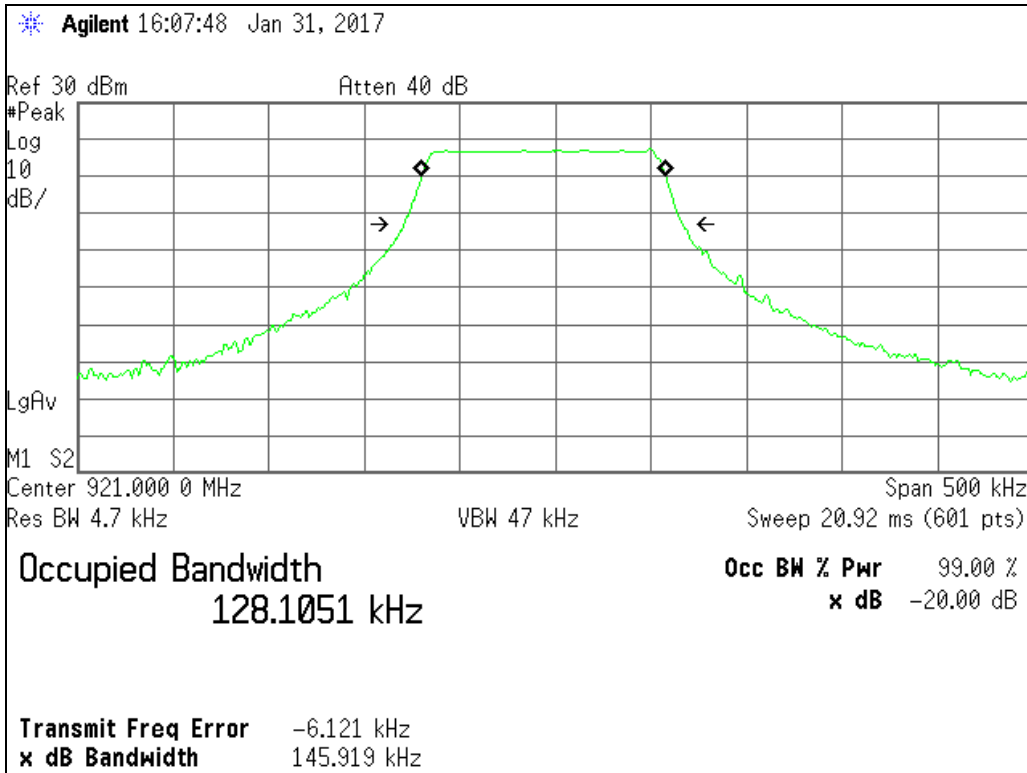

18 Out-of-band and conducted spurious emissions

18.1 Definition

Out-of-band emission.

Emission on a frequency or frequencies immediately outside the necessary bandwidth that results from the modulation process but excluding spurious emissions.

Spurious emission.

Emission on a frequency or frequencies that are outside the necessary bandwidth and the level of which may be reduced without affecting the corresponding transmission of information. Spurious emissions include harmonic emissions, parasitic emissions, intermodulation products, and frequency conversion products, but exclude out-of-band emissions.

18.2 Test Parameters

Test Location:	Element Hull
Test Chamber:	Lab 4
Test Standard and Clause:	ANSI C63.10-2013, Clause 7.8.8
EUT Channels / Frequencies Measured:	Low / Mid / High
EUT Channel Bandwidths:	200 kHz
Deviations From Standard:	None
Measurement BW:	100 kHz
Spectrum Analyzer Video BW: (requirement at least 3x RBW)	300 kHz
Measurement Detector:	Peak
Measurement Range:	30 MHz to 26.5 GHz

Environmental Conditions (Normal Environment)

Temperature: 22 °C	+15 °C to +35 °C (as declared)
Humidity: 33 % RH	20 % RH to 75 % RH (as declared)
Supply: 6V dc	

18.3 Test Limits

In any 100 kHz bandwidth outside the frequency band in which the spread spectrum or digitally modulated device is operating, the RF power that is produced shall be at least 20 dB below that in the 100 kHz bandwidth within the band that contains the highest level of the desired power, based on either an RF conducted or a radiated measurement, provided that the transmitter demonstrates compliance with the peak conducted power limits. If the transmitter complies with the conducted power limits based on the use of root-mean-square averaging over a time interval, the attenuation required shall be 30 dB instead of 20 dB. Attenuation below the general field strength limits specified in FCC 47CFR15.209(a) / RSS-Gen is not required.

18.4 Test Method

With the EUT setup as per section 9 of this report and connected as per Figure viii, the emissions from the EUT were measured on a spectrum analyser.

The measurements were performed with EUT set at its maximum duty. All modulation schemes, data rates and power settings were used to observe the worst case configuration in each bandwidth.

Figure viii Test Setup

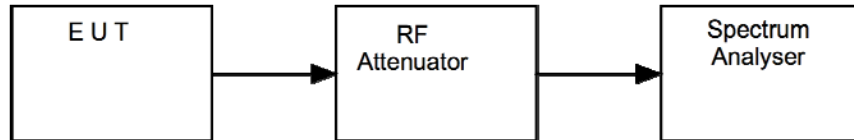

18.5 Test Equipment

Equipment Type	Manufacturer	Equipment Description	Element No	Due For Calibration
E4440A	Agilent	Spectrum Analyser	REF837	22/06/2017

18.6 Test Results

Modulation: LoRa; Data rate: LoRa; Power setting: 0x0F						
Channel Frequency (MHz)	Emission Frequency (MHz)	Analyzer Level (dBm)	Emission Level (dBm)	Limit (dBm)	Margin (dB)	Result
915.25	915.217	17.11	17.11	N/A	N/A	PASS

Plots show limit line 20 dB below the peak fundamental, all spurious signals are > 20dB below this limit and so also comply with a limit line 30 dB below the peak fundamental. (Average PSD measurements were made due to the Hybrid mode).

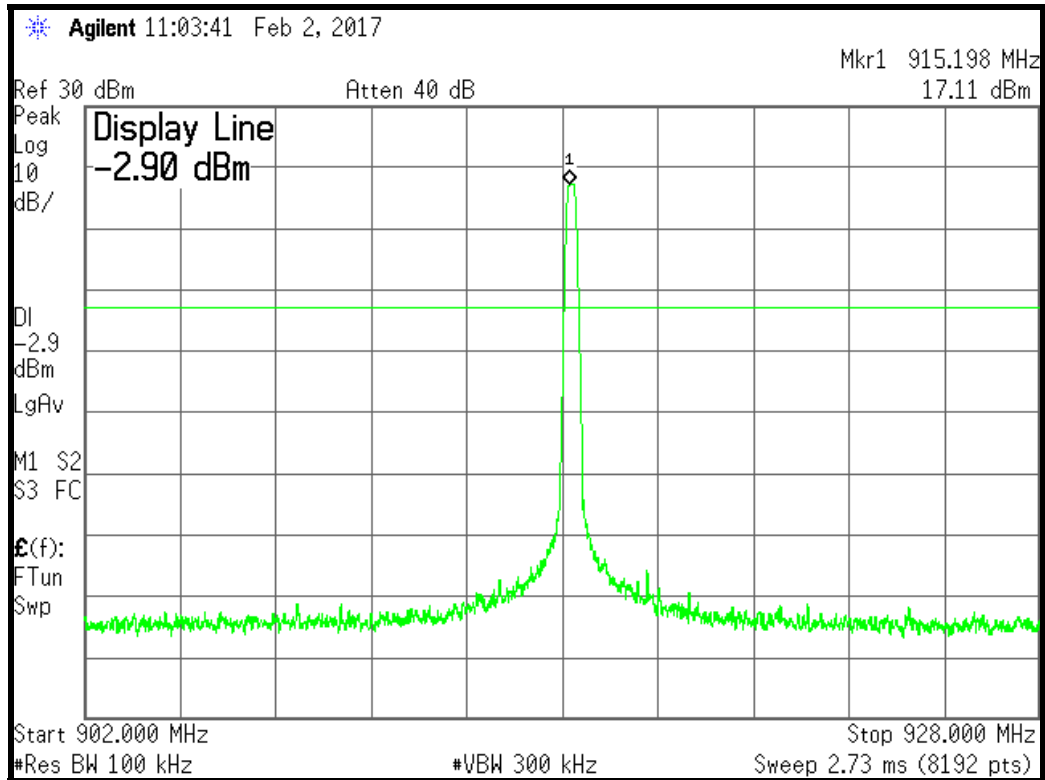

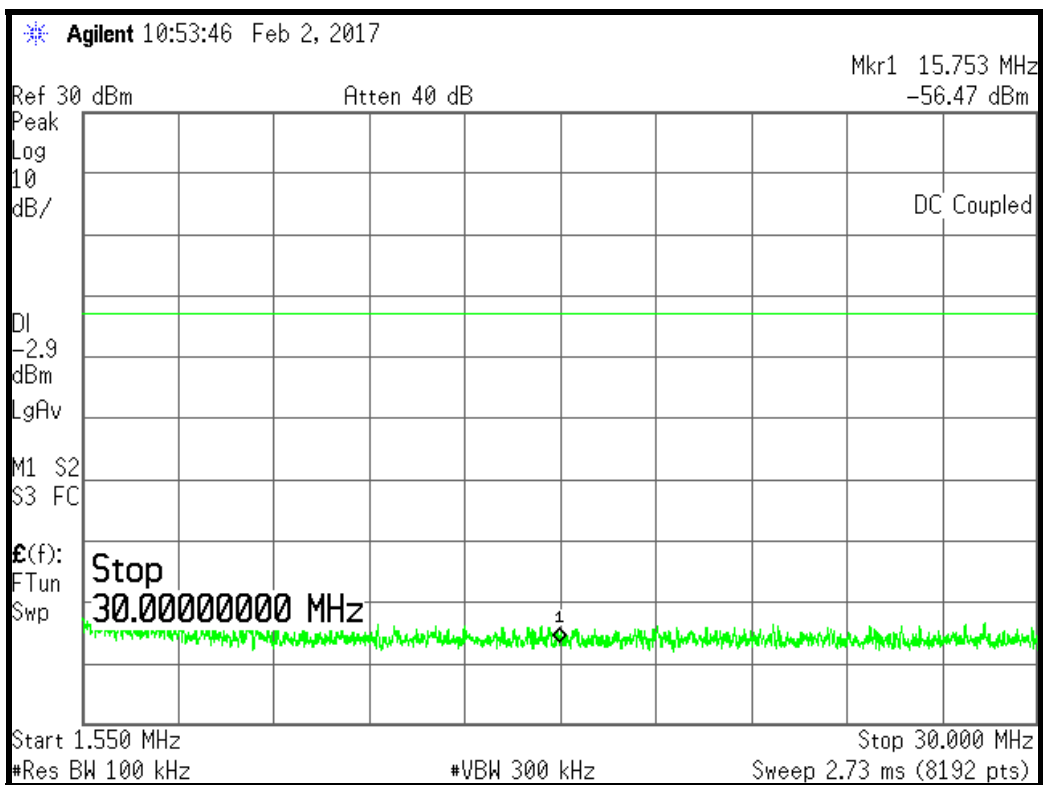
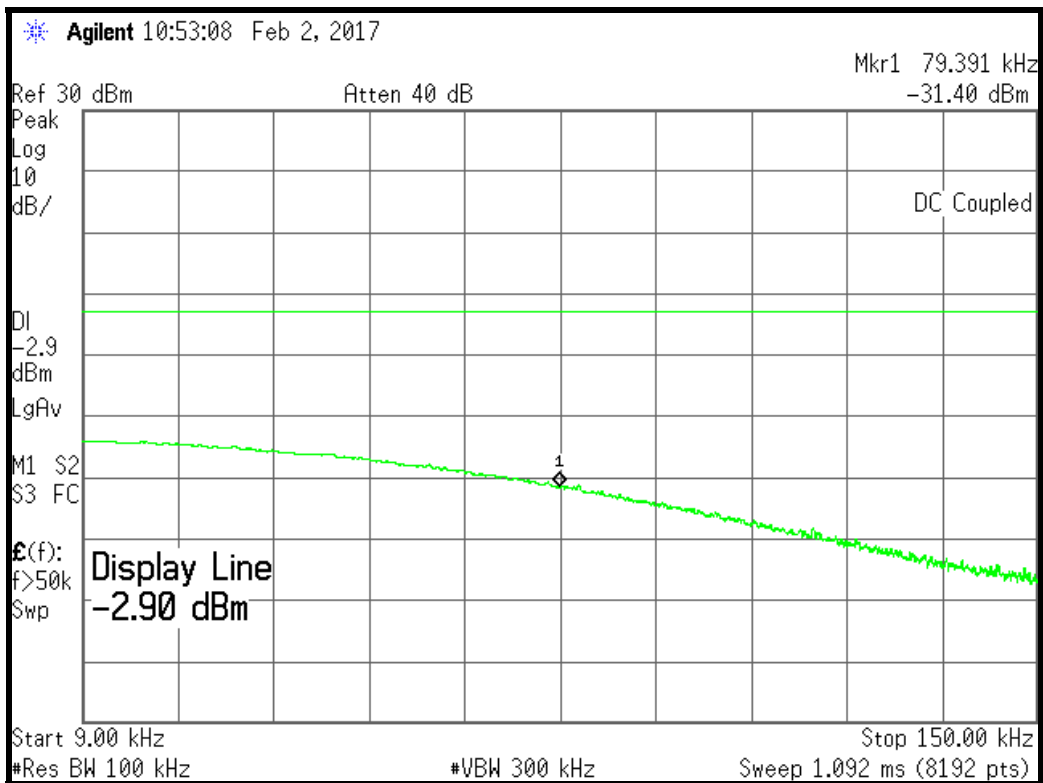

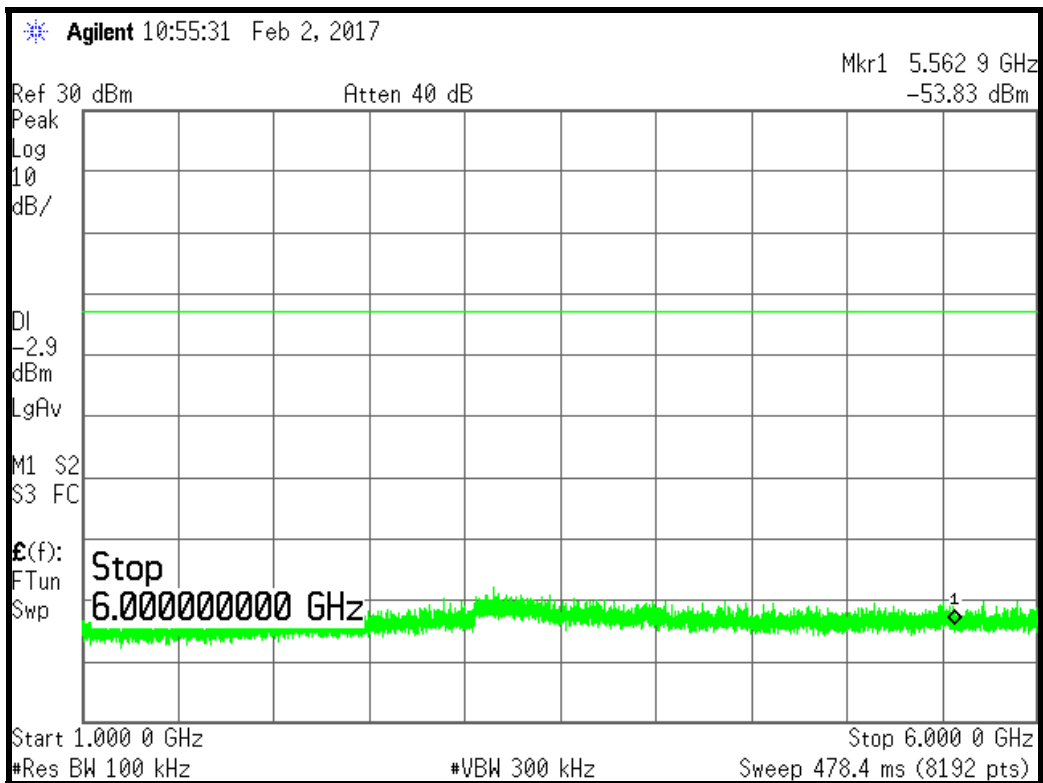
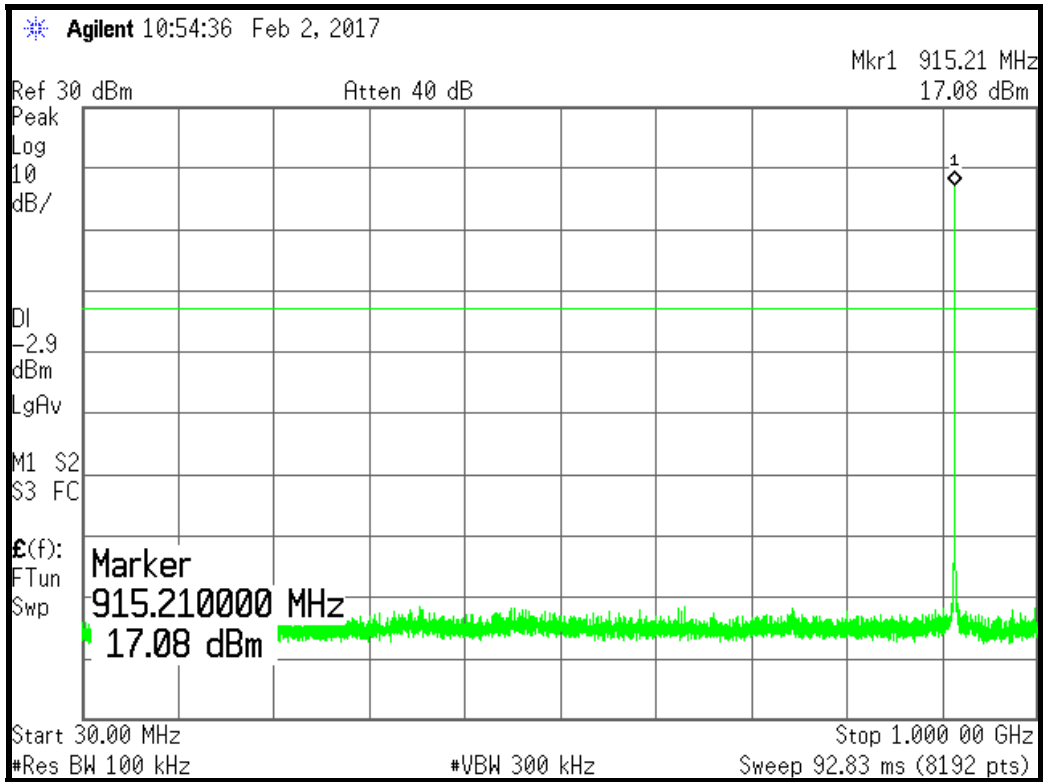

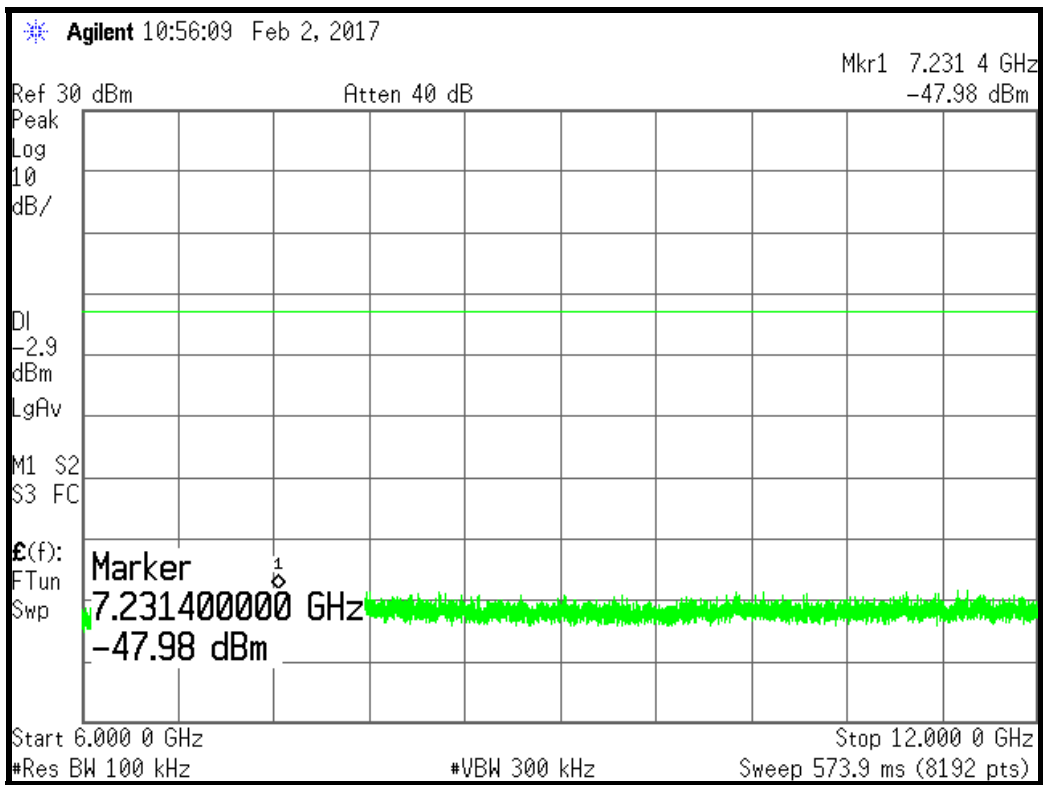

Modulation: LoRa; Data rate: LoRa; Power setting: 0x0F						
Channel Frequency (MHz)	Emission Frequency (MHz)	Analyzer Level (dBm)	Emission Level (dBm)	Limit (dBm)	Margin (dB)	Result
921.00	921.0248	17.14.9	17.14	N/A	N/A	PASS

Plots show limit line 20 dB below the peak fundamental, all spurious signals are > 20dB below this limit and so also comply with a limit line 30 dB below the peak fundamental. (Average PSD measurements were made due to the Hybrid mode).

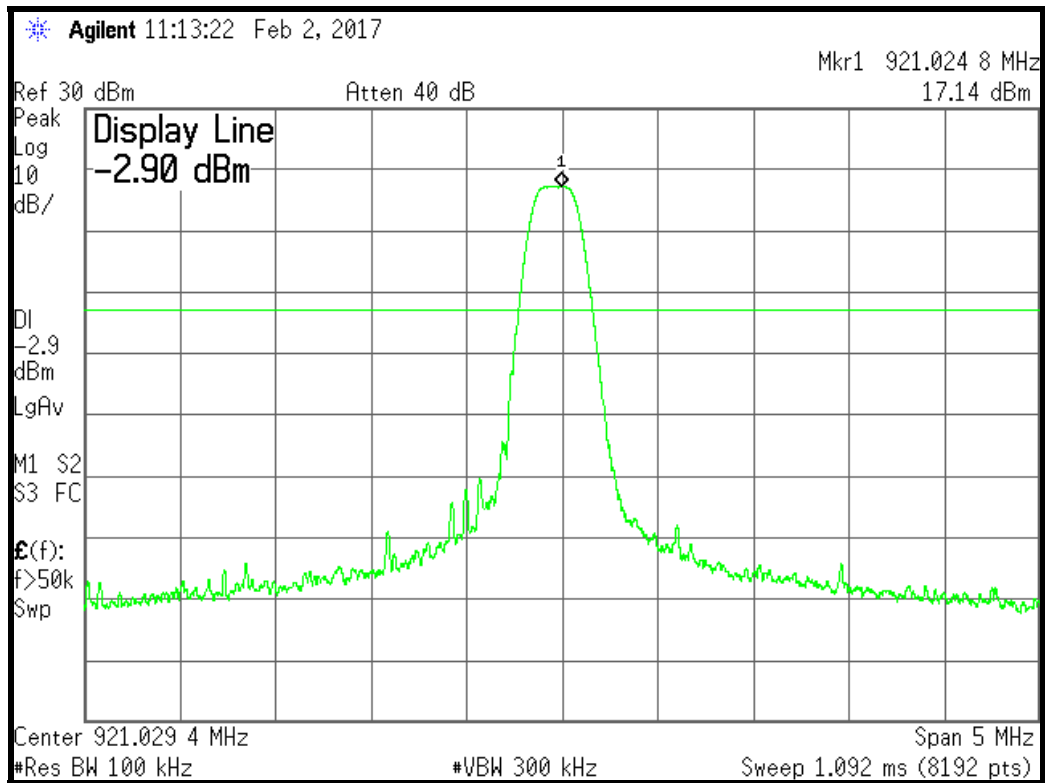

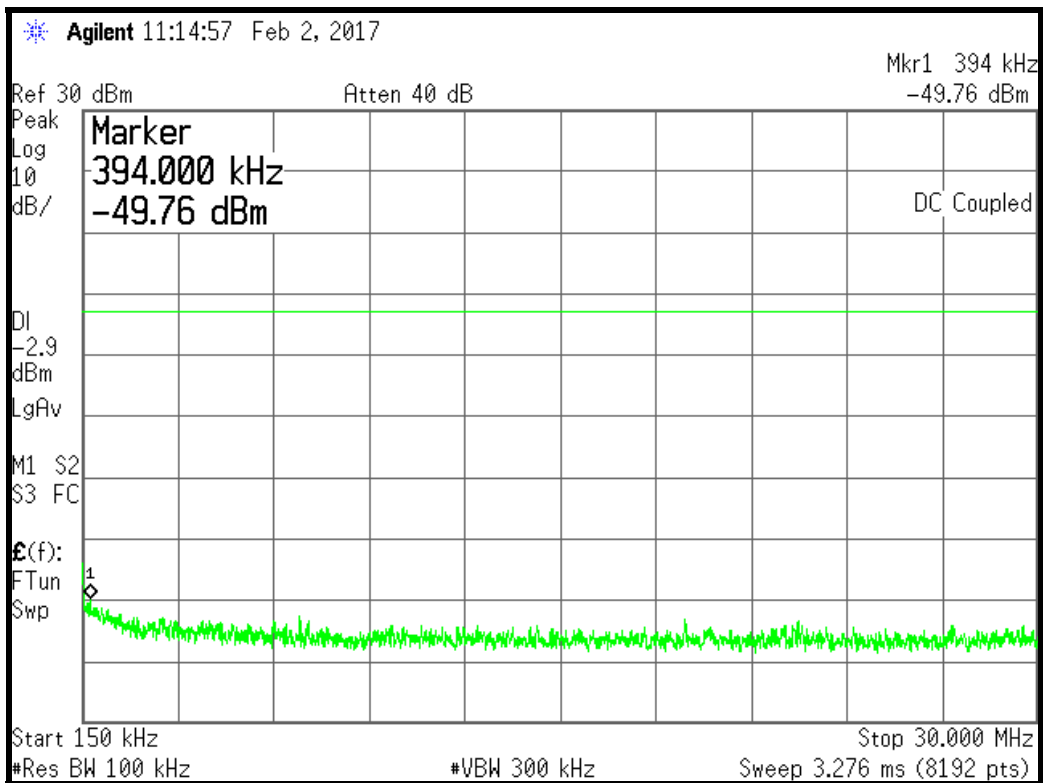
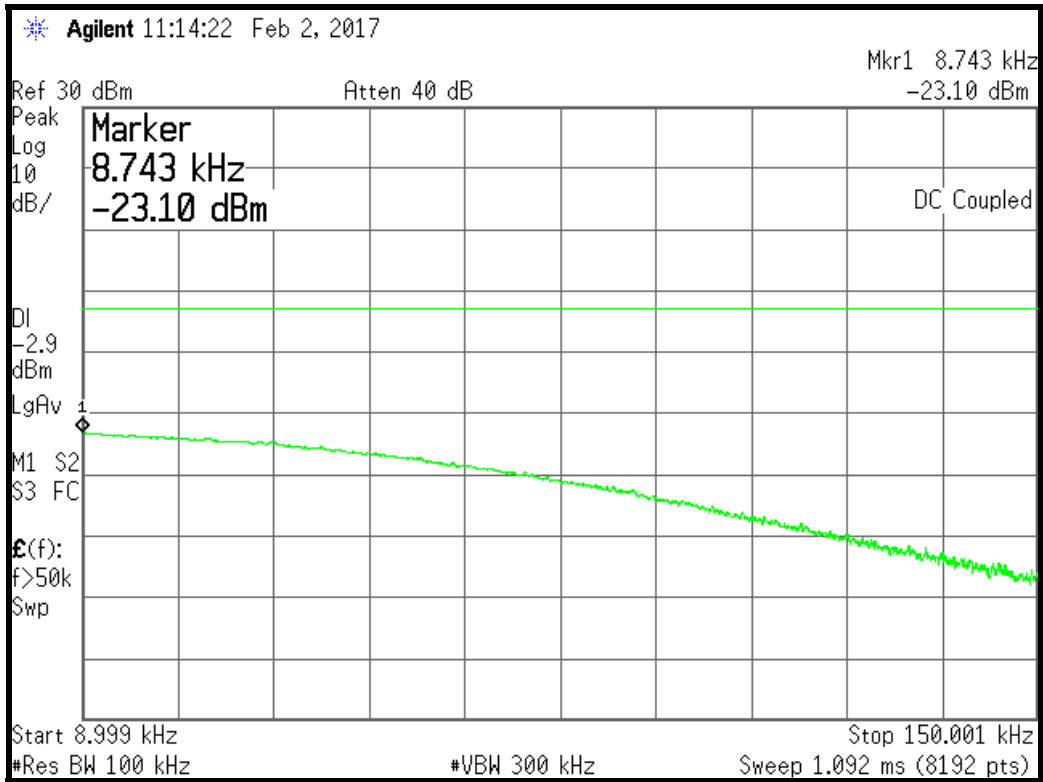

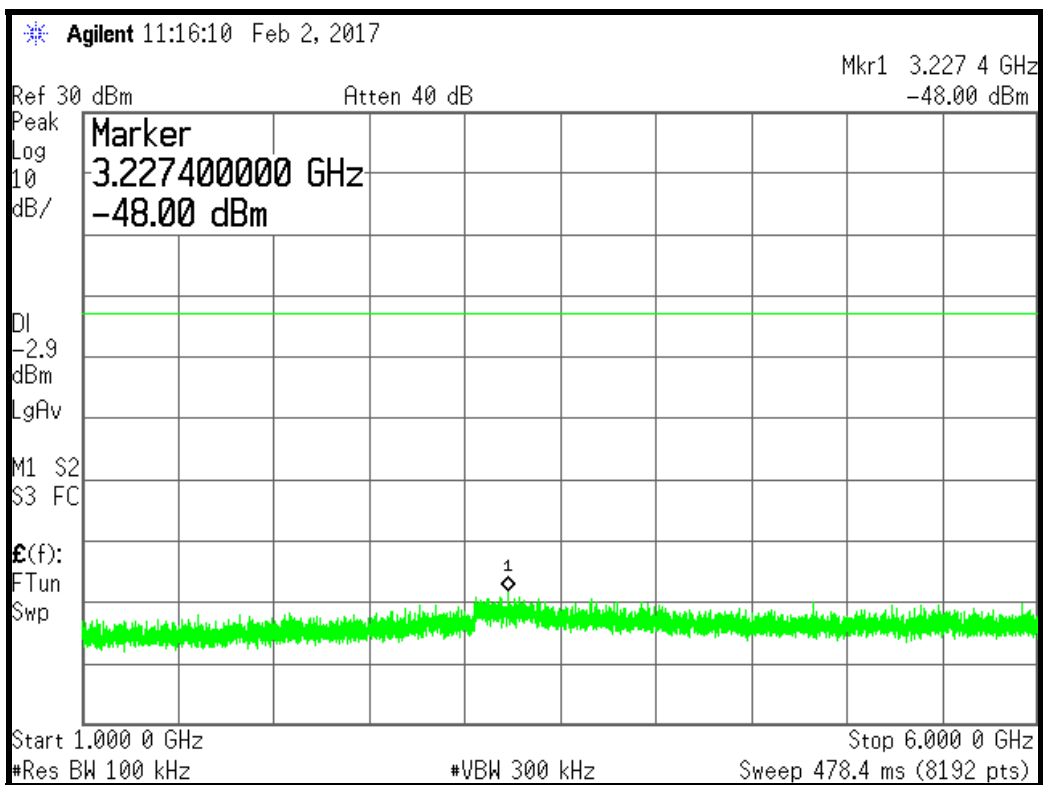
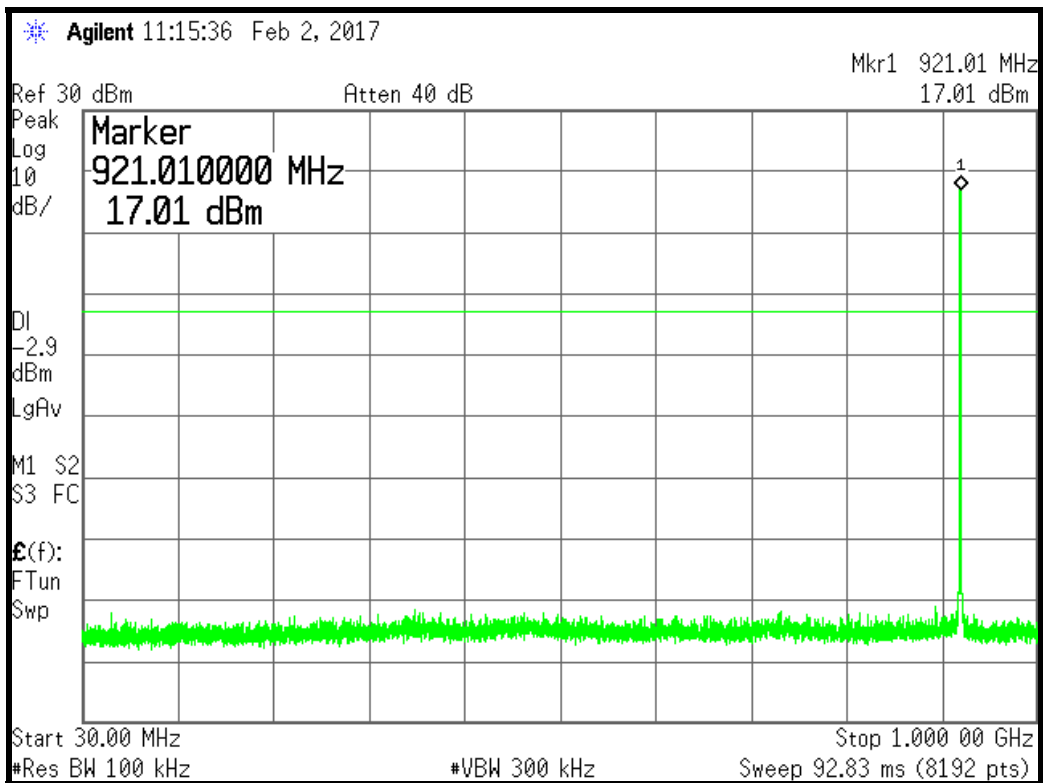

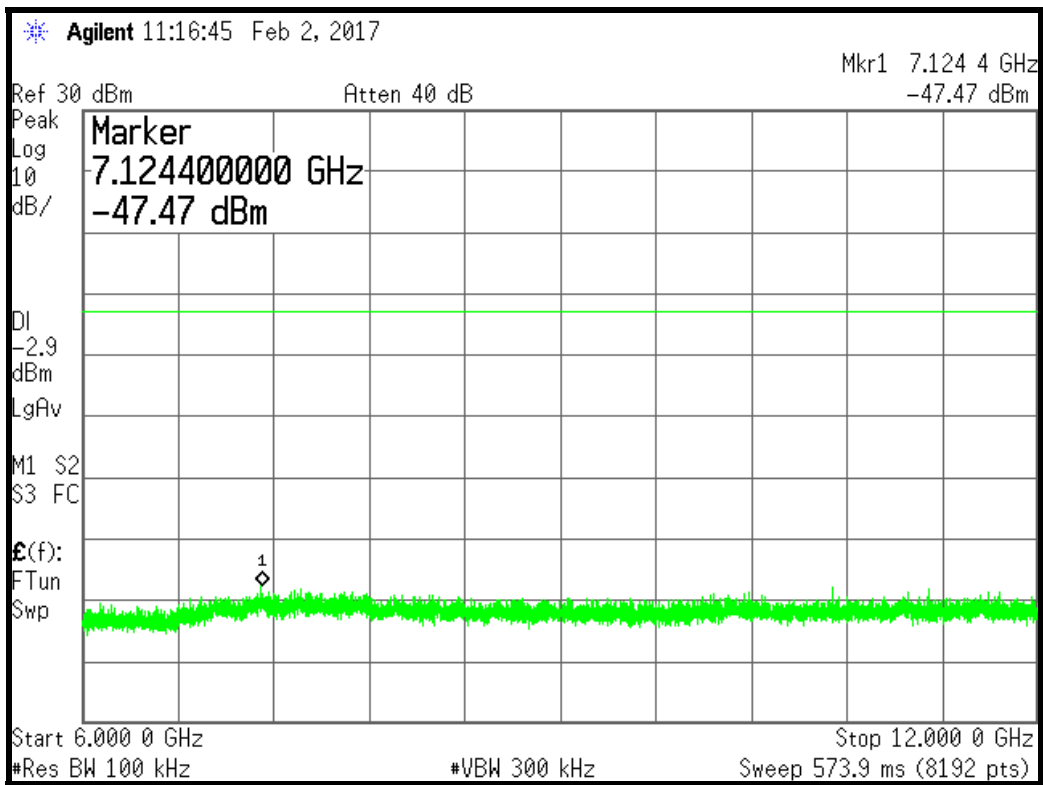

Modulation: LoRa; Data rate: LoRa; Power setting: 0x0F						
Channel Frequency (MHz)	Emission Frequency (MHz)	Analyzer Level (dBm)	Emission Level (dBm)	Limit (dBm)	Margin (dB)	Result
927.50	927.4435	17.06	17.06	N/A	N/A	PASS

Plots show limit line 20 dB below the peak fundamental, all spurious signals are > 20dB below this limit and so also comply with a limit line 30 dB below the peak fundamental. (Average PSD measurements were made due to the Hybrid mode).

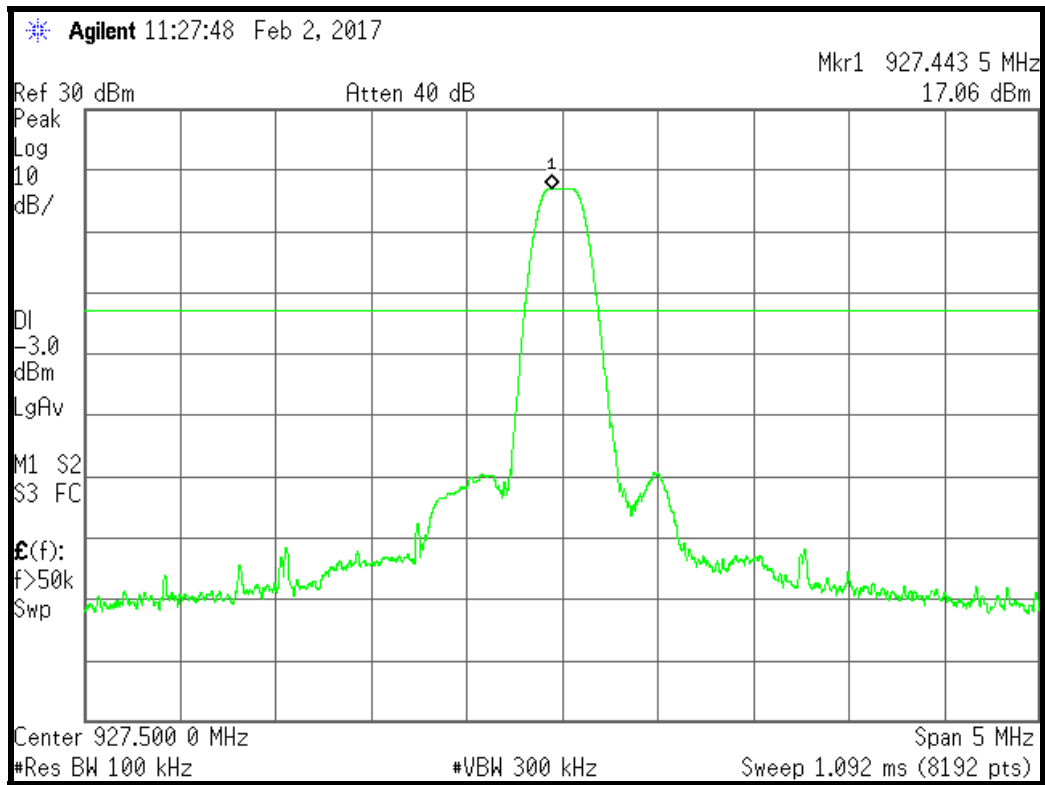

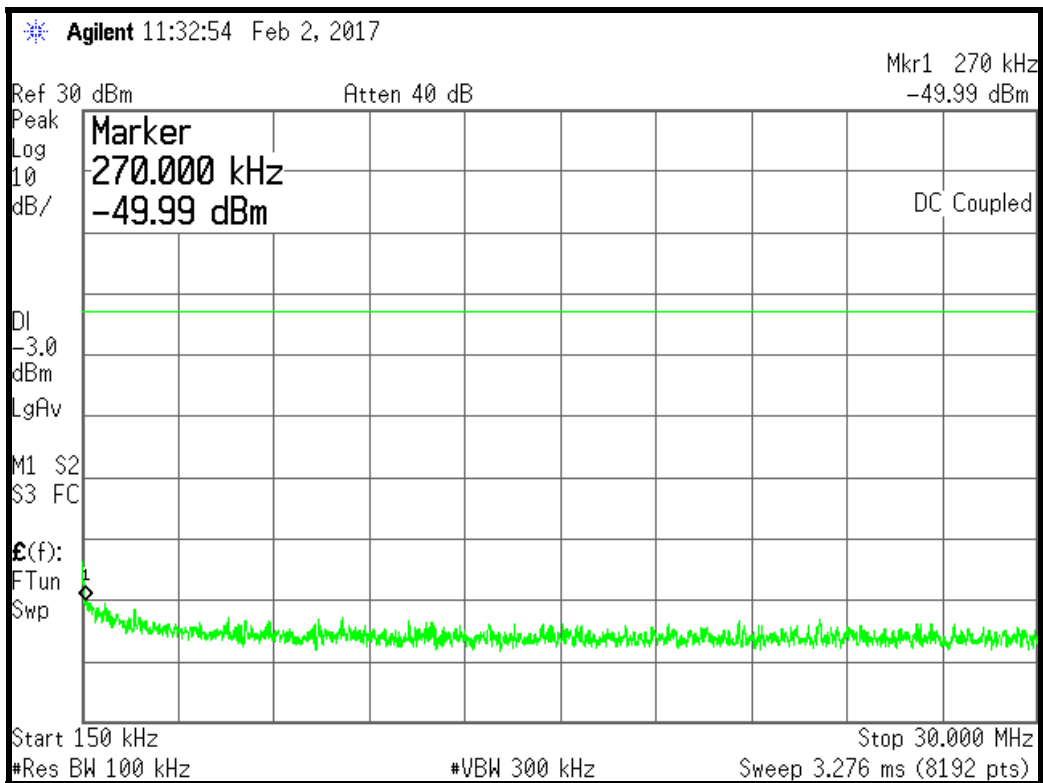
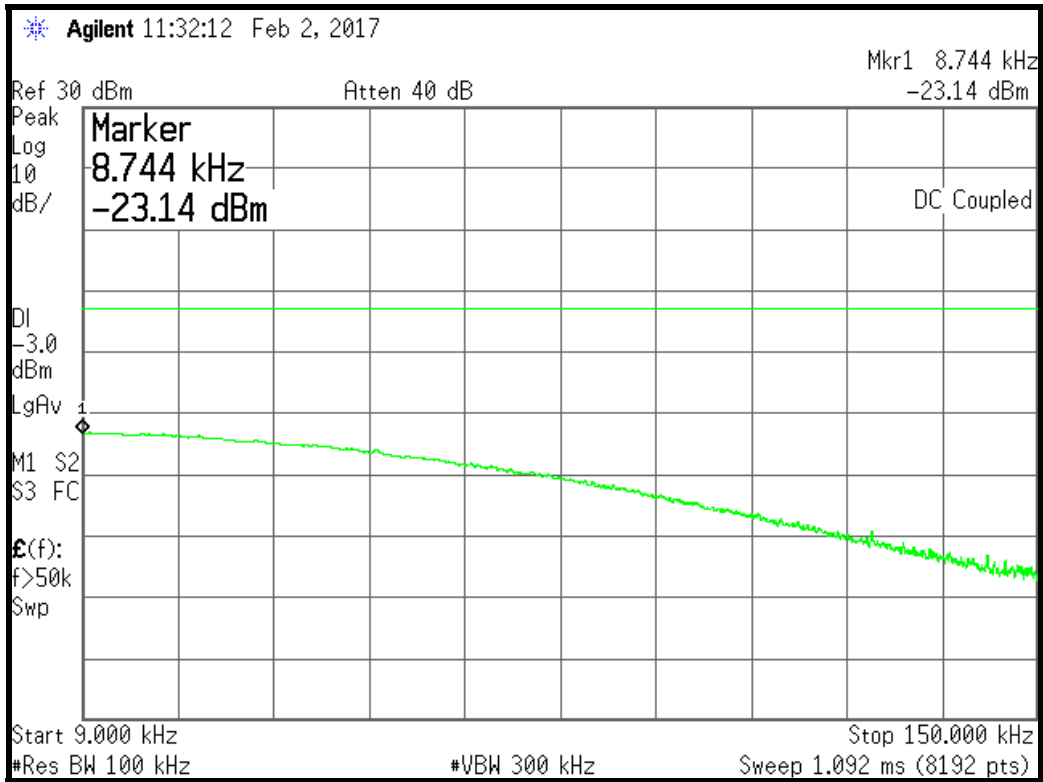

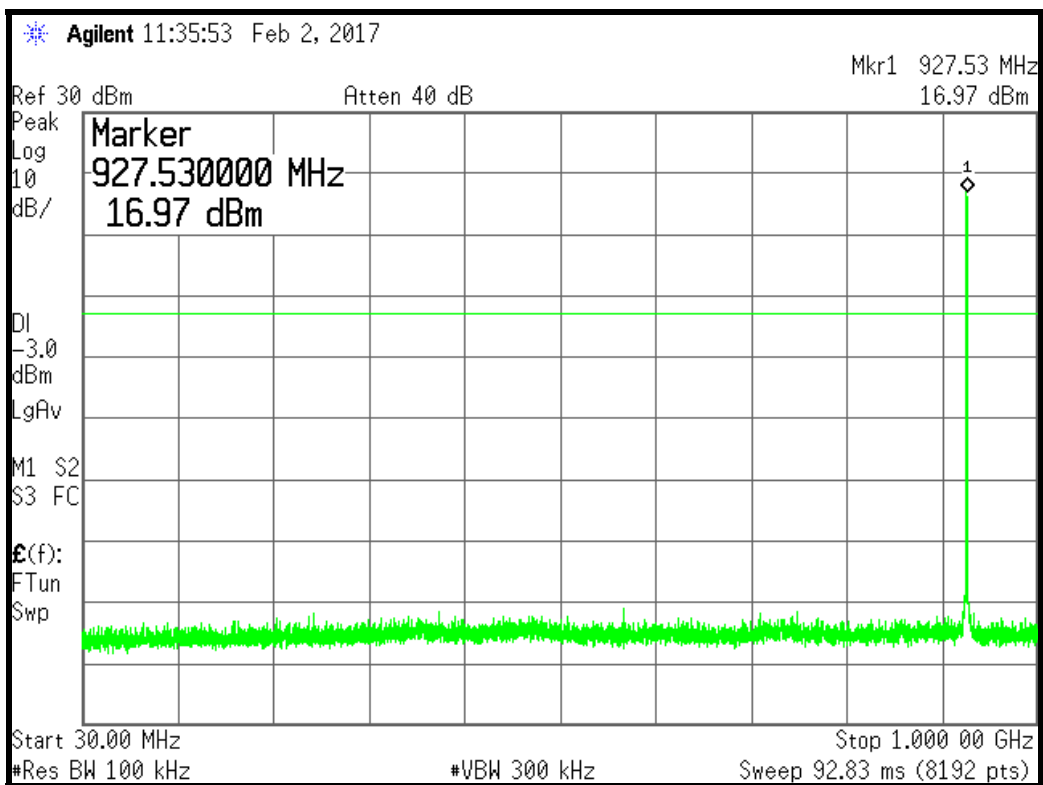
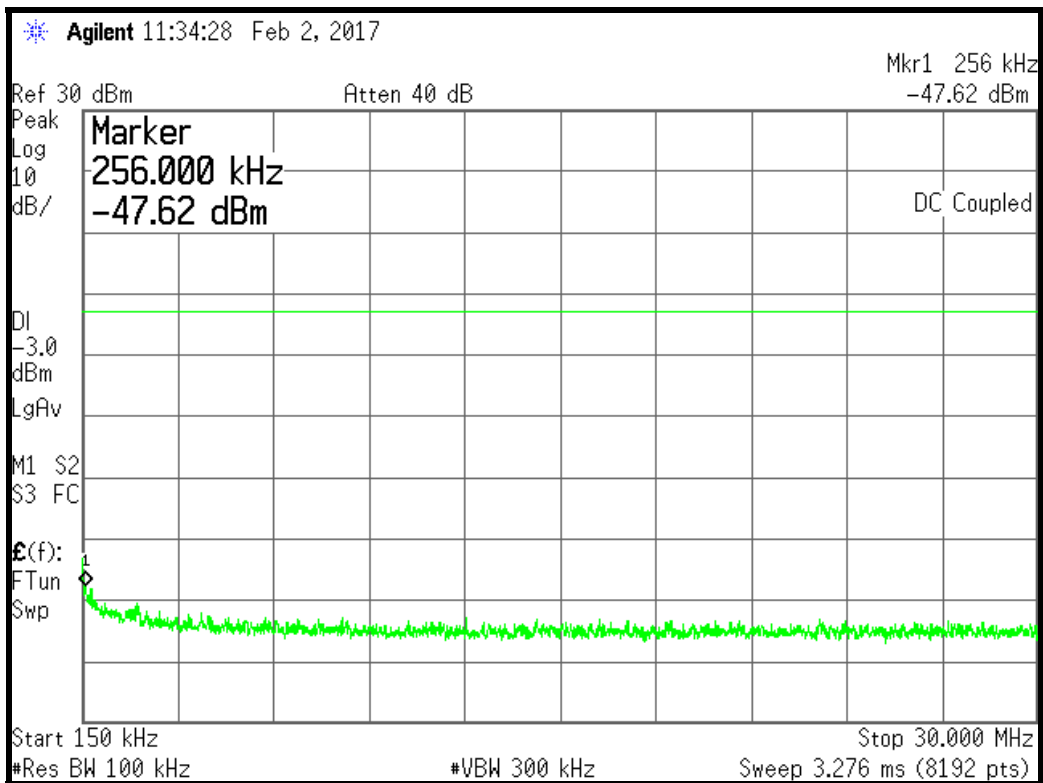

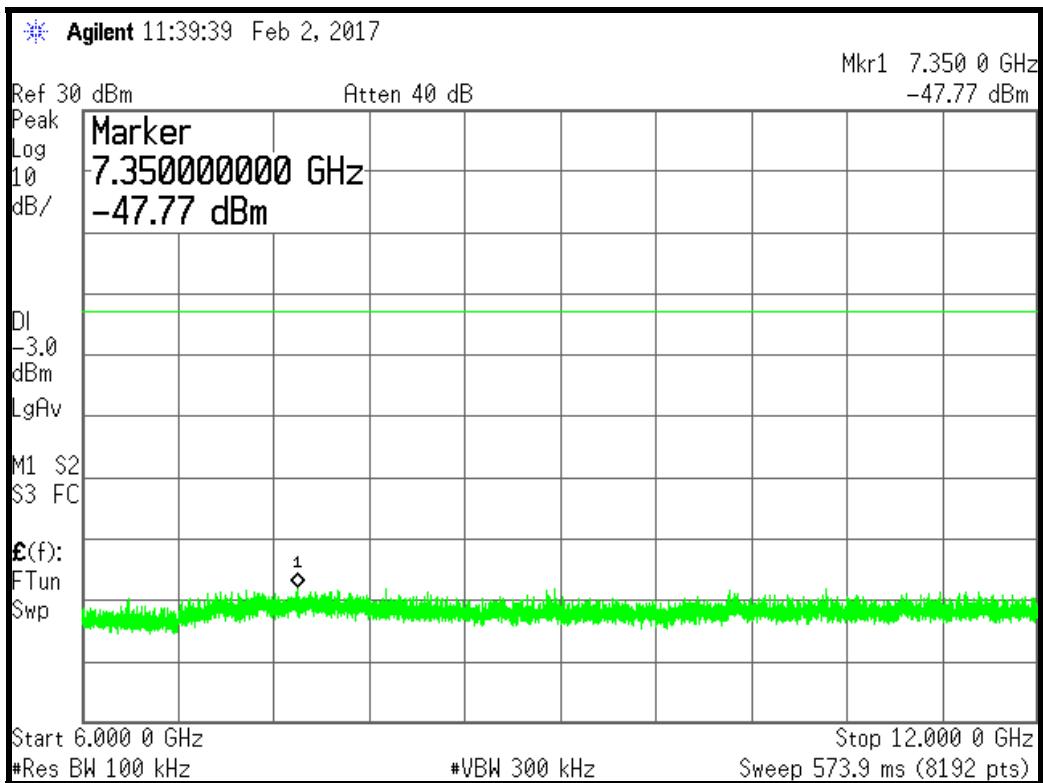
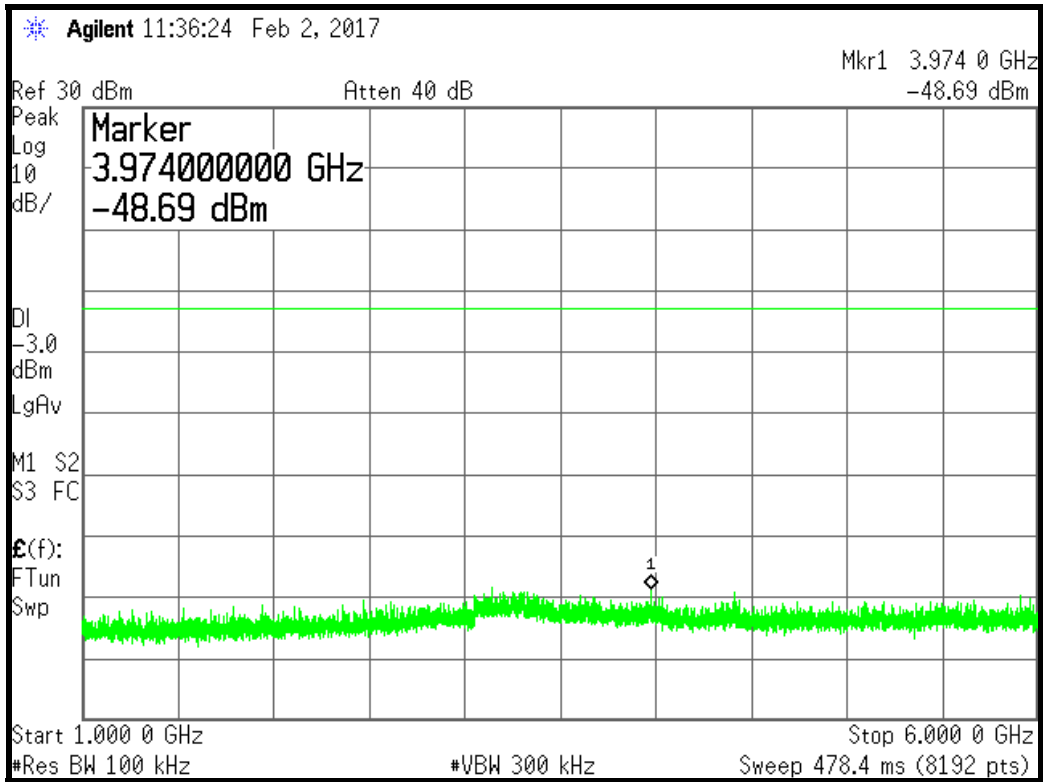

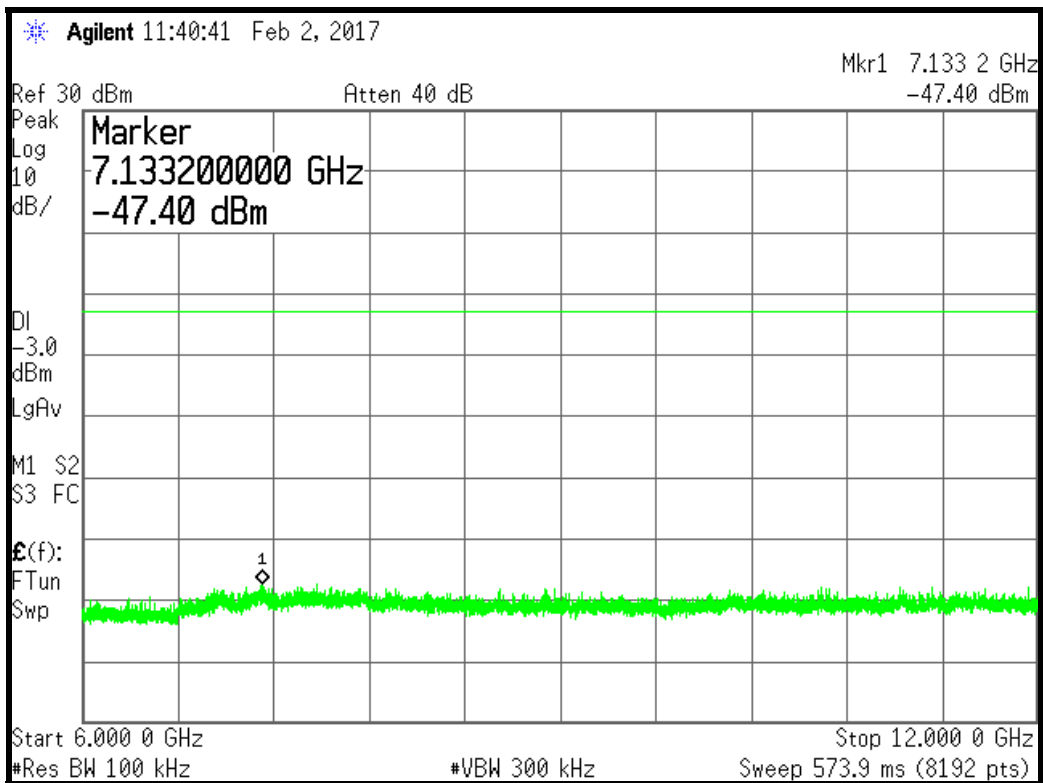

Hopping mode Band Edge plot showing both Band Edges:

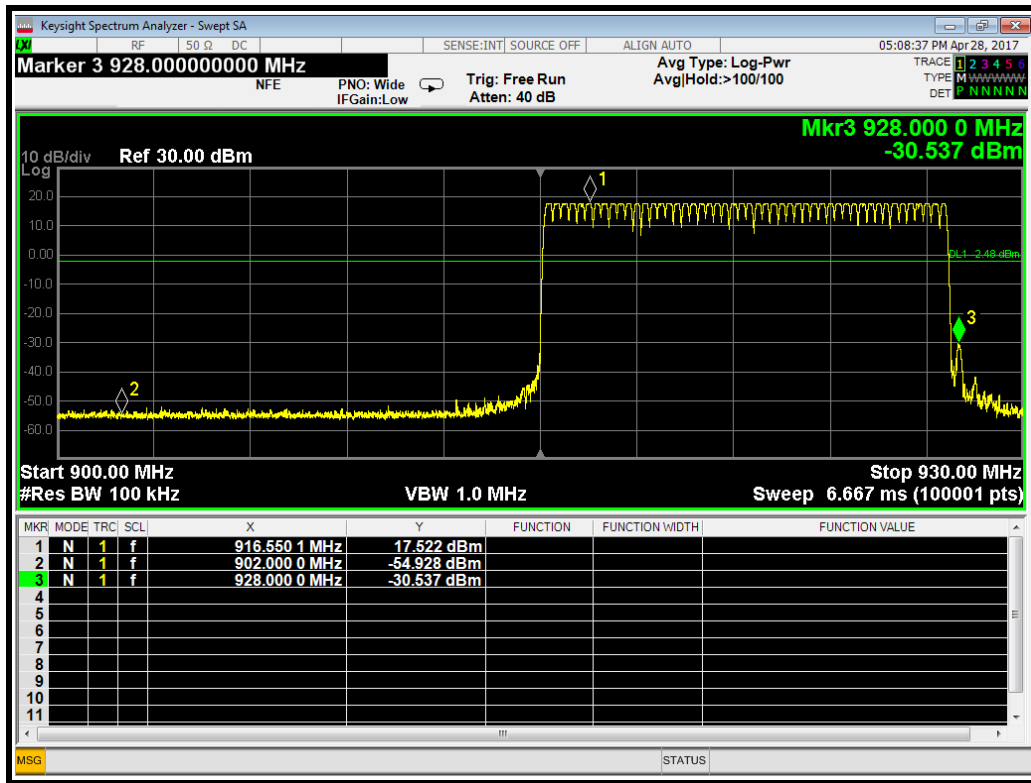

19 Power spectral density

19.1 Definition

The power per unit bandwidth.

19.2 Test Parameters

Test Location:	Element Hull
Test Chamber:	Lab 4
Test Standard and Clause:	ANSI C63.10-2013, Clause 11.10
EUT Channels / Frequencies Measured:	Low / Mid / High
EUT Channel Bandwidths:	200 kHz
Deviations From Standard:	None
Measurement BW:	3 kHz
Spectrum Analyzer Video BW: (requirement at least 3x RBW)	10 kHz
Measurement Span: (requirement 1.5 times Channel BW)	400 kHz
Measurement Detector:	Peak

Environmental Conditions (Normal Environment)

Temperature: 22 °C	+15 °C to +35 °C (as declared)
Humidity: 33 % RH	20 % RH to 75 % RH (as declared)
Supply: 6V dc	

19.3 Test Limit

The transmitter power spectral density conducted from the transmitter to the antenna shall not be greater than 8 dBm in any 3 kHz band during any time interval of continuous transmission.

19.4 Test Method

With the EUT setup as per section 9 of this report and connected as per Figure vi, the peak emission of the EUT was measured on a spectrum analyser, with path losses taken into account.

The measurements were performed with EUT set at its maximum duty. All modulation schemes, data rates and power settings were used to observe the worst case configuration in each bandwidth.

Figure vi Test Setup

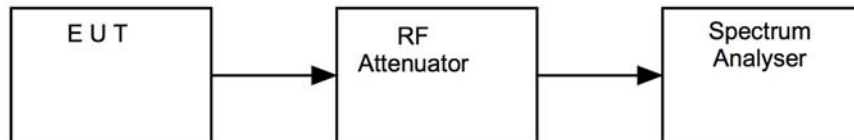

19.5 Test Equipment

Equipment Type	Manufacturer	Equipment Description	Element No	Due For Calibration
FSV	Rohde & Schwarz	Spectrum Analyser	N/A	07/06/2017

19.6 Test Results

Modulation: LoRa; Data rate: LoRa; Power setting: 0x0F				
Channel Frequency (MHz)	Analyzer Level (dBm)	Cable loss (dB)	Power (dBm)	Result
915.25	2.63	0	2.63	PASS
921.00	2.69	0	2.69	PASS
927.5	3.17	0	3.17	PASS

Measurements were made using the AVGPSD-1 method detailed in 558074 D01 DTS Meas Guidance v04

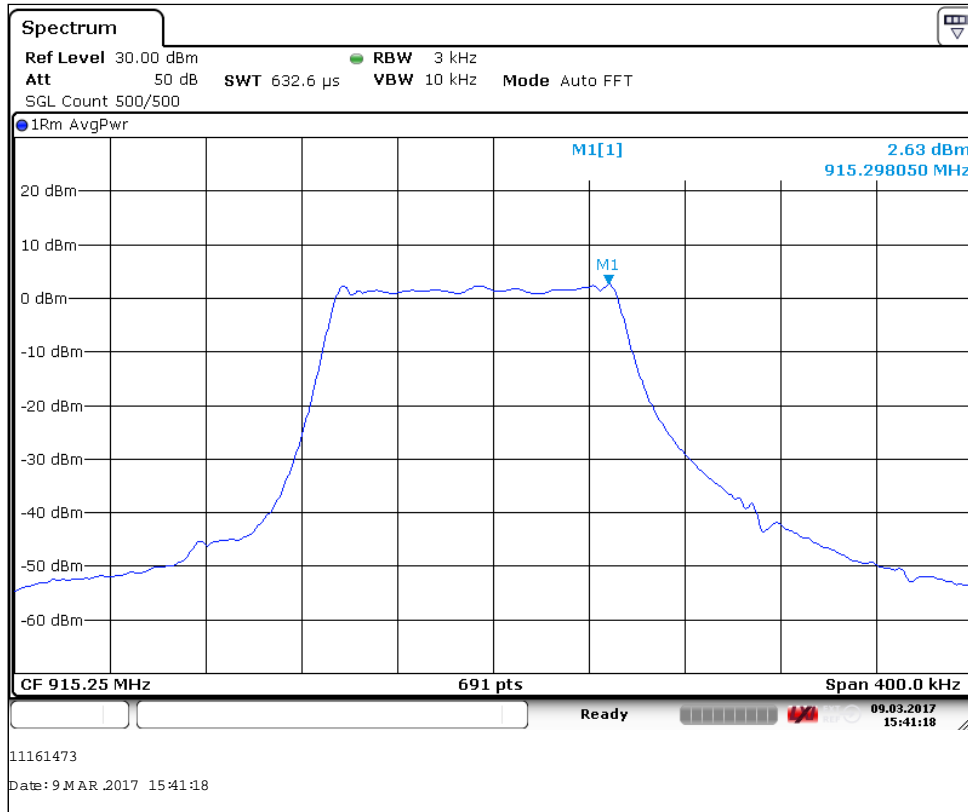

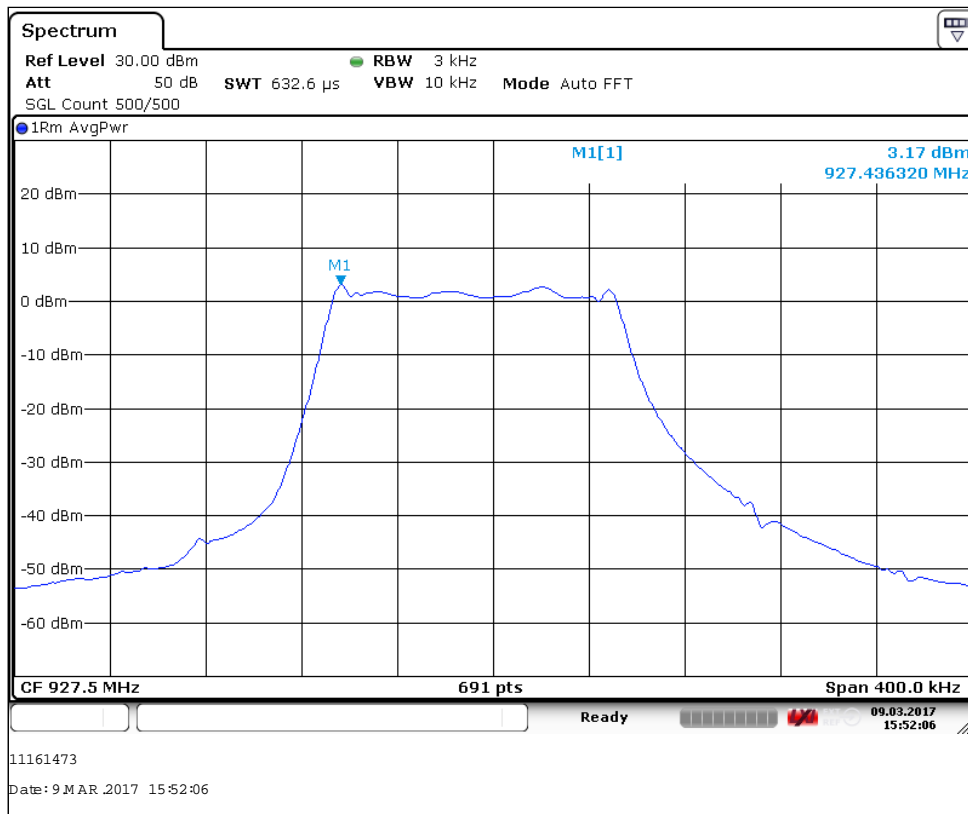
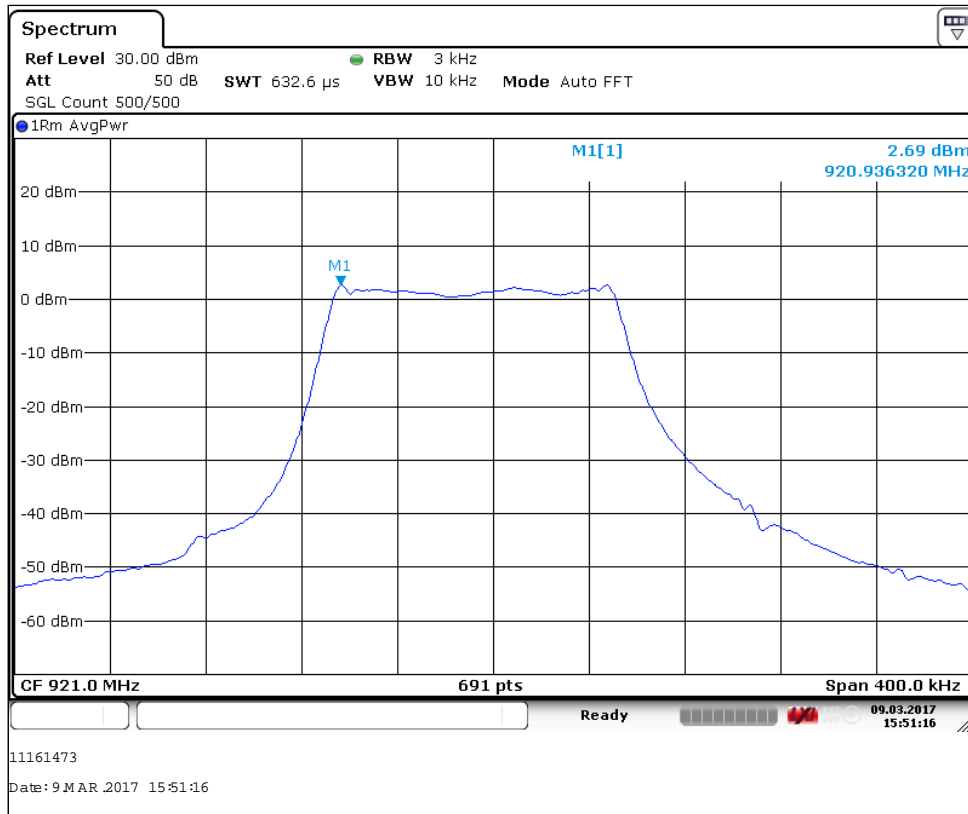

20 Measurement Uncertainty

Calculated Measurement Uncertainties

All statements of uncertainty are expanded standard uncertainty using a coverage factor of 1.96 to give a 95 % confidence:

[1] Radiated spurious emissions

Uncertainty in test result (30 MHz to 1 GHz) = **4.6 dB**

Uncertainty in test result (1 GHz to 18 GHz) = **4.7 dB**

[2] AC power line conducted emissions

Uncertainty in test result = **3.4 dB**

[3] Occupied bandwidth

Uncertainty in test result = **15.5 %**

[4] Conducted carrier power

Uncertainty in test result (Power Meter) = **1.08 dB**

[5] Conducted / radiated RF power out-of-band

Uncertainty in test result – up to 8.1 GHz = **3.31 dB**

Uncertainty in test result – 8.1 GHz to 15.3 GHz = **4.43 dB**

Uncertainty in test result (30 MHz to 1 GHz) = **4.6 dB**

Uncertainty in test result (1 GHz to 18 GHz) = **4.7 dB**

[6] Frequency separation

Uncertainty in test result (Spectrum Analyser) = **3.6 kHz**

[7] Accumulated channel occupancy time

Uncertainty in test result = **7.98 %**

21 RF Exposure

MPE Calculation

As per KDB 447498

47 CFR §§1.1307 and 2.1091

2.1091 Radio frequency radiation exposure evaluation: Portable devices.

For purposes of these requirements mobile devices are defined by the FCC as transmitters designed to be used in other than fixed locations and to generally be used in such a way that a separation distance of at least 20 centimetres is normally maintained between radiating structures and the body of the user or nearby persons. These devices are normally evaluated for exposure potential with relation to the MPE limits. As the 20cm separation specified under FCC rules may not be achievable under normal operation of the EUT, an RF exposure calculation is needed to show the minimum distance required to be less than 0.6mW/cm² power density limit, as required under FCC rules

Prediction of MPE limit at a given distance

Equation from KDB 447498 D01

$$S = \frac{1.64 ERP}{4 \pi R^2} \quad \text{re - arranged} \quad R = \sqrt{\frac{1.64 ERP}{S 4 \pi}}$$

where:

S = power density

R = distance to the centre of radiation of the antenna

ERP = EUT Maximum power

Result:

Prediction Frequency (MHz)	Maximum ERP (mW)	Power density limit (S) (mW/cm ²)	Distance (R) cm required to be less than 0.6mW/cm ² (cm)
915.25	437.52	0.6	9.76

Prediction Frequency (MHz)	Maximum Conducted power (mW)	Power density limit (S) (mW/cm ²)	Distance (R) cm required to be less than 0.6mW/cm ² (cm)
915.25	180.30	0.6	6.26