

3-DH5

4.8. Pseudorandom Frequency Hopping Sequence

LIMIT

FCC CFR Title 47 Part 15 Subpart C Section 15.247 (a)(1):

Frequency hopping systems shall have hopping channel carrier frequencies separated by a minimum of 25 kHz or the 20 dB bandwidth of the hopping channel, whichever is greater. Alternatively, frequency hopping systems operating in the 2400–2483.5 MHz band may have hopping channel carrier frequencies that are separated by 25 kHz or two-thirds of the 20 dB bandwidth of the hopping channel, whichever is greater, provided the systems operate with an output power no greater than 125 mW. The system shall hop to channel frequencies that are selected at the system hopping rate from a pseudo randomly ordered list of hopping frequencies. Each frequency must be used equally on the average by each transmitter. The system receivers shall have input bandwidths that match the hopping channel bandwidths of their corresponding transmitters and shall shift frequencies in synchronization with the transmitted signals.

TEST RESULTS

The pseudorandom frequency hopping sequence may be generated in a nine-stage shift register whose 5th and 9th stage outputs are added in a modulo-two addition stage. And the result is fed back to the input of the first stage. The sequence begins with the first one of 9 consecutive ones, for example: the shift register is initialized with nine ones.

- Number of shift register stages:9
- Length of pseudo-random sequence:2⁹-1=511 bits
- Longest sequence of zeros:8(non-inverted signal)

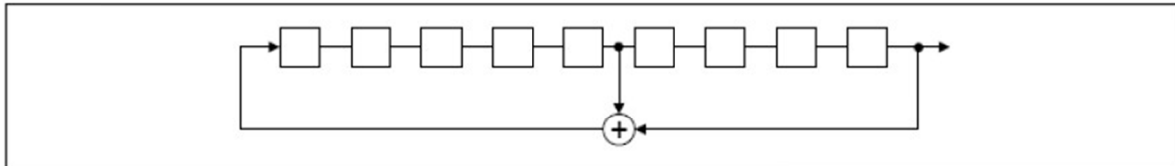

Linear Feedback Shift Register for Generation of the PRBS sequence

An example of pseudorandom frequency hopping sequence as follows:

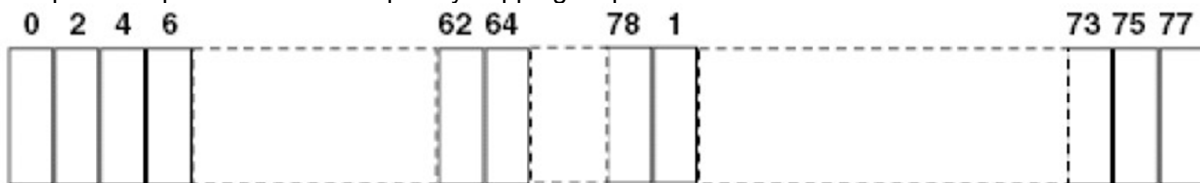

Each frequency used equally on the average by each transmitter. The system receiver have input bandwidths that match the hopping channel bandwidths of their corresponding transmitter and shift frequencies in synchronization with the transmitted signals.

4.9. Restricted band (radiated)

LIMIT

FCC CFR Title 47 Part 15 Subpart C Section 15.209

Frequency	Limit (dBuV/m @3m)	Value
Above 1GHz	54.00	Average
	74.00	Peak

TEST CONFIGURATION

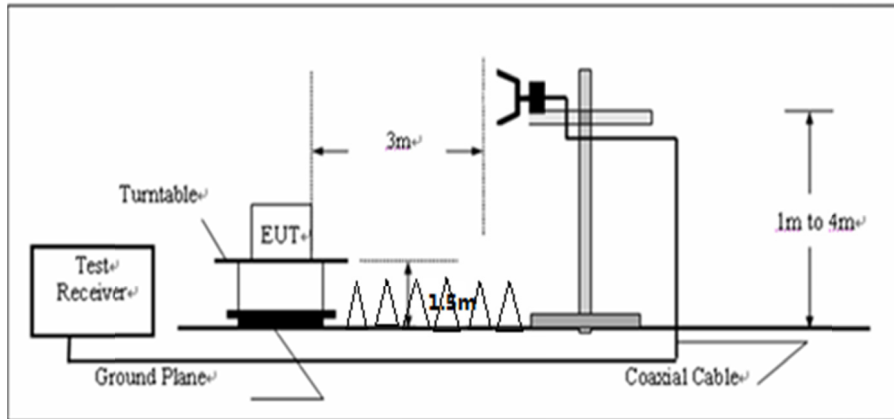

TEST PROCEDURE

1. The EUT was setup and tested according to ANSI C63.10:2013 for compliance to FCC 47CFR 15.247 requirements.
2. The EUT is placed on a turn table which is 1.5 meter above ground. The turn table is rotated 360 degrees to determine the position of the maximum emission level.
3. The EUT was positioned such that the distance from antenna to the EUT was 3 meters.
4. The antenna is scanned from 1 meter to 4 meters to find out the maximum emission level. This is repeated for both horizontal and vertical polarization of the antenna. In order to find the maximum emission, all of the interface cables were manipulated according to ANSI C63.10:2013 on radiated measurement.
5. The receiver set as follow:
 RBW=1MHz, VBW=3MHz for Peak value
 RBW=1MHz, VBW=10Hz for Average value.
6. The frequency range from 2310MHz to 2483.5MHz harmonic is checked.

TEST RESULTS

CH00									
Frequency (MHz)	Read Level (dBuV)	Antenna Factor (dB/m)	Cable Loss (dB)	Preamp Factor (dB)	Level (dBuV/m)	Limit Line (dBuV/m)	Margin Limit (dB)	Polarization	Test value
2389.02	54.33	27.53	6.81	37.24	51.43	74	-22.57	Vertical	Peak
2389.35	53.42	27.53	6.81	37.24	50.52	74	-23.48	Horizontal	
2386.47	45.64	27.53	6.81	37.24	42.74	54	-11.26	Vertical	Average
2386.29	45.75	27.53	6.81	37.24	42.85	54	-11.15	Horizontal	

CH78									
Frequency (MHz)	Read Level (dBuV)	Antenna Factor (dB/m)	Cable Loss (dB)	Preamp Factor (dB)	Level (dBuV/m)	Limit Line (dBuV/m)	Margin Limit (dB)	Polarization	Test value
2485.68	51.58	27.85	6.96	37.92	48.47	74	-25.53	Vertical	Peak
2482.75	53.56	27.85	6.96	37.92	50.45	74	-23.55	Horizontal	
2482.97	44.58	27.85	6.96	37.92	41.47	54	-12.53	Vertical	Average
2482.36	45.89	27.85	6.96	37.92	42.78	54	-11.22	Horizontal	

Note: 1. Level = Read + Antenna Factor + Cable Loss - Preamp Factor

2. Have pre-scan all modulation mode, found the GFSK modulation which it was worst case, so only the worst case's data on the test report.

4.10. Bandedge and Spurious Emission (conducted)

LIMIT

FCC CFR Title 47 Part 15 Subpart C Section 15.247 (d):

In any 100 kHz bandwidth outside the frequency band in which the spread spectrum intentional radiator is operating, the radio frequency power that is produced by the intentional radiator shall be at least 20 dB below that in the 100 kHz bandwidth within the band that contains the highest level of the desired power, based on either an RF conducted or a radiated measurement.

TEST CONFIGURATION

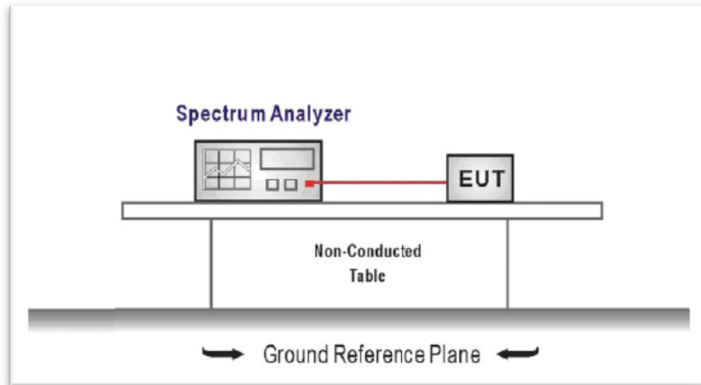

TEST PROCEDURE

1. The transmitter output was connected to the spectrum analyzer through an attenuator.
2. Conducted spurious emission the bandwidth of the fundamental frequency was measured by spectrum analyzer with RBW=100 KHz and VBW=300KHz.
3. Below -20dB of the highest emission level in operating band.

TEST RESULTS

Test plot as follows:

GFSK

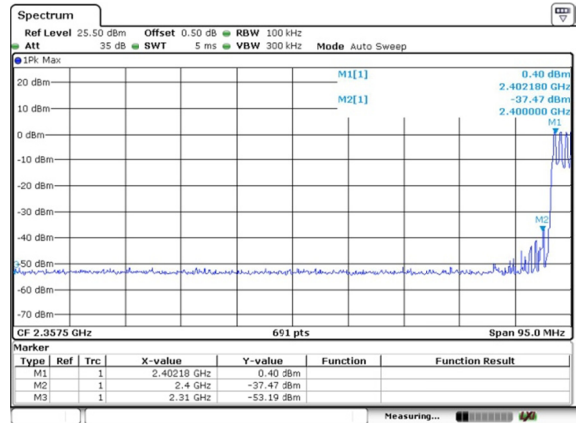
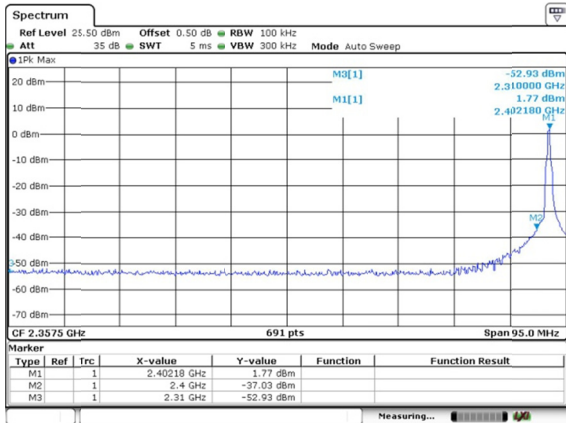

Bandedge- no hopping mode (CH00)

Bandedge- hopping mode (CH00)

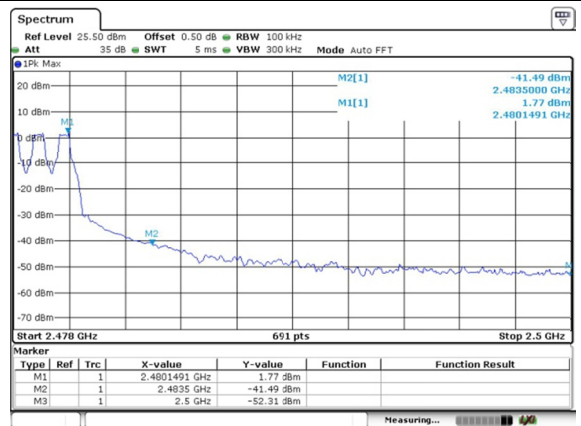
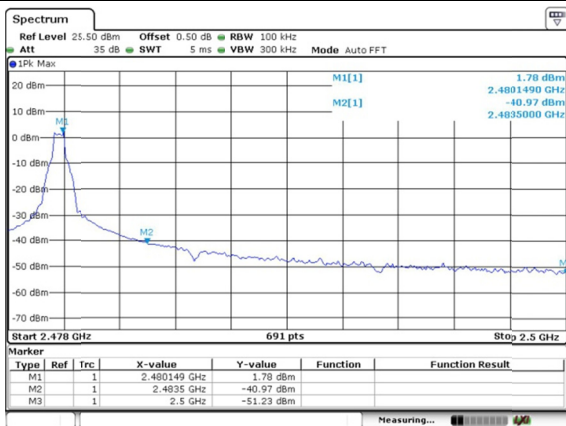

Bandedge- no hopping mode (CH78)

Bandedge- hopping mode (CH78)

GFSK Tx Spurious Emission

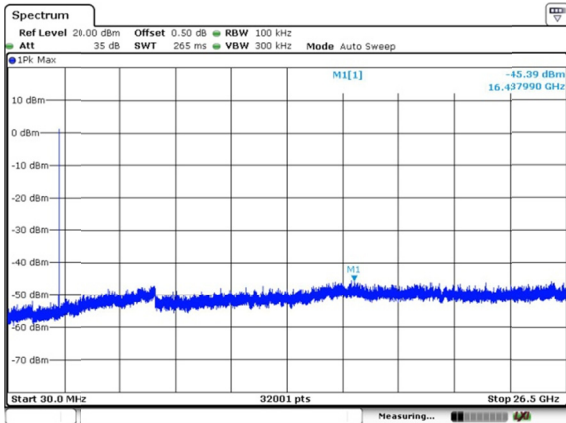

CH00

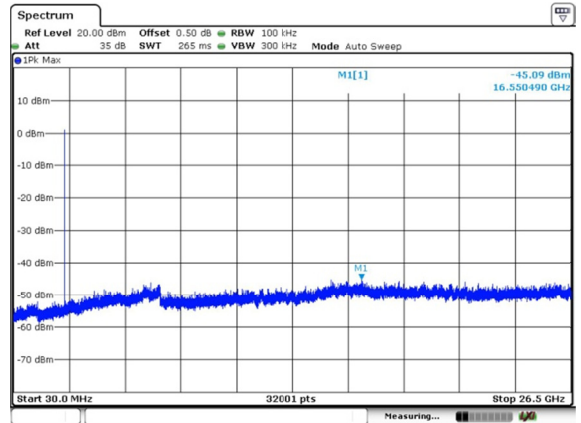

CH39

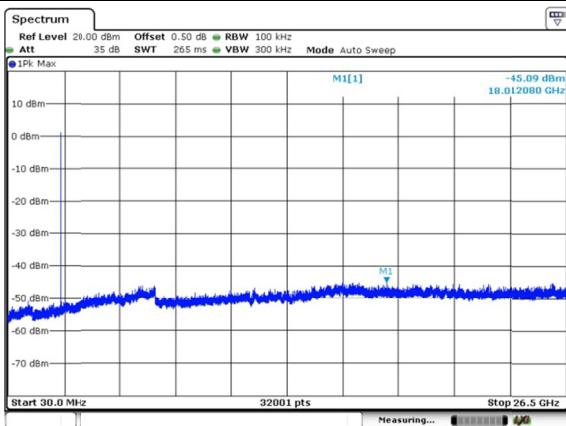

CH78

$\pi/4$ DQPSK

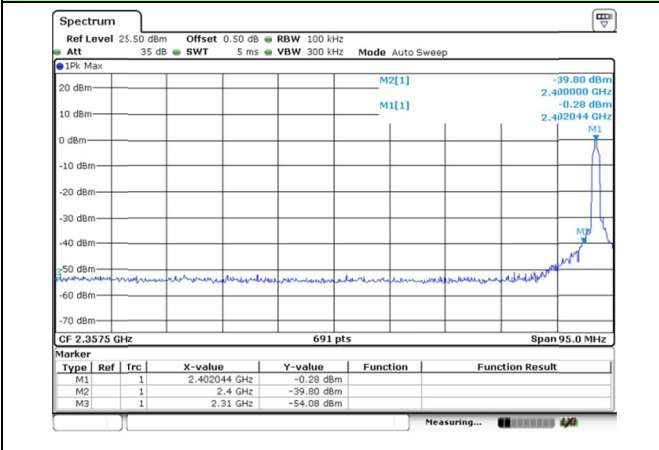

Bandedge- no hopping mode (CH00)

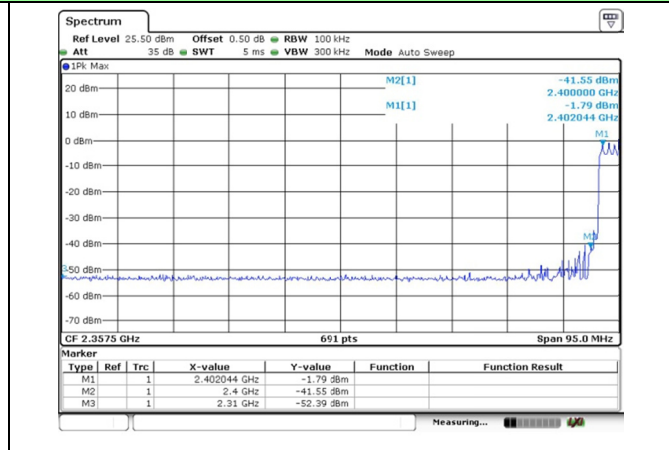

Bandedge- hopping mode (CH00)

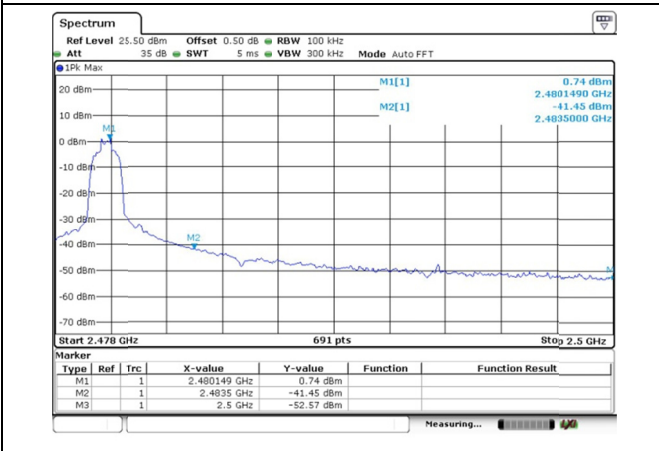

Bandedge- no hopping mode (CH78)

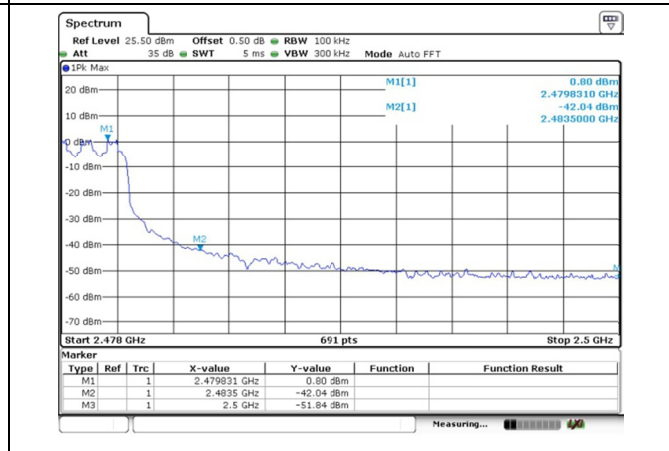

Bandedge- hopping mode (CH78)

$\pi/4$ DQPSK Tx Spurious Emission

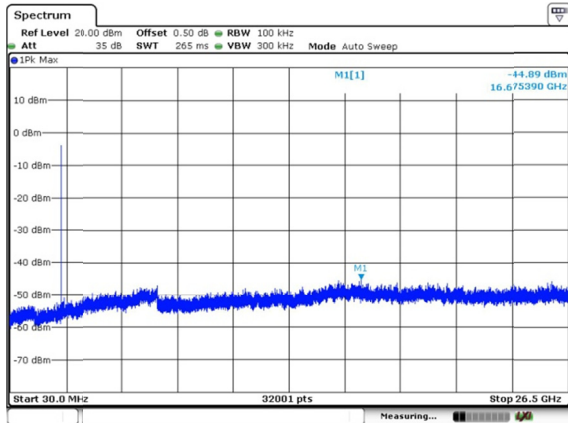

CH00

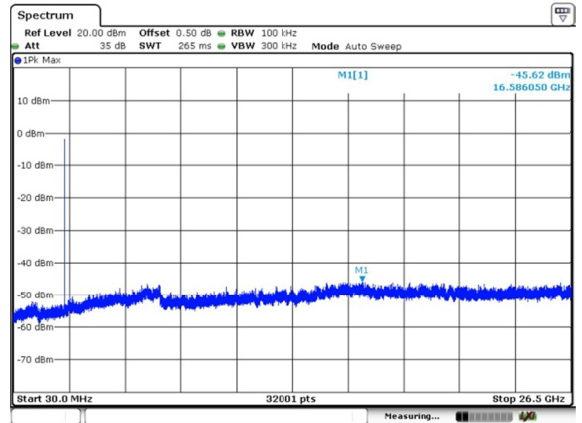

CH39

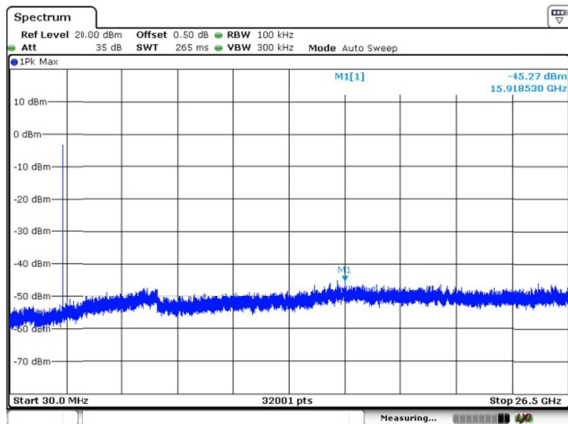

CH78

8DPSK

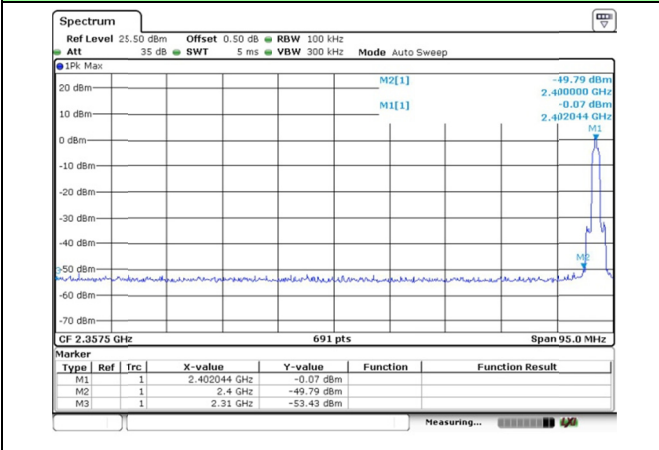

Bandedge- no hopping mode (CH00)

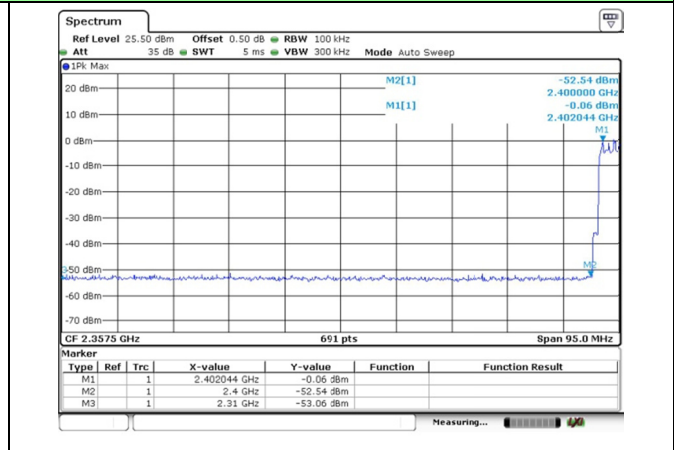

Bandedge- hopping mode (CH00)

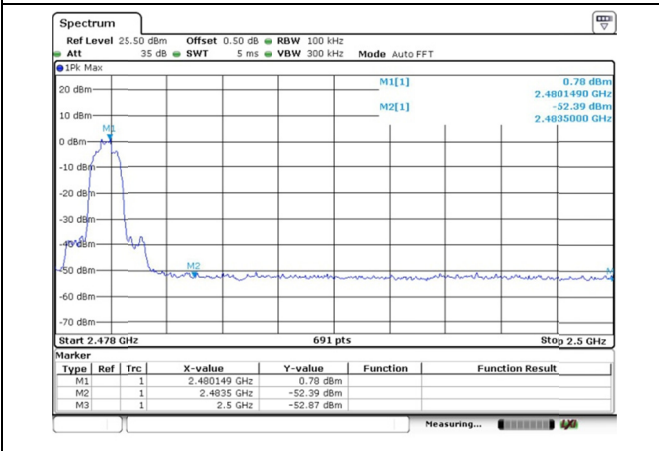

Bandedge- no hopping mode (CH78)

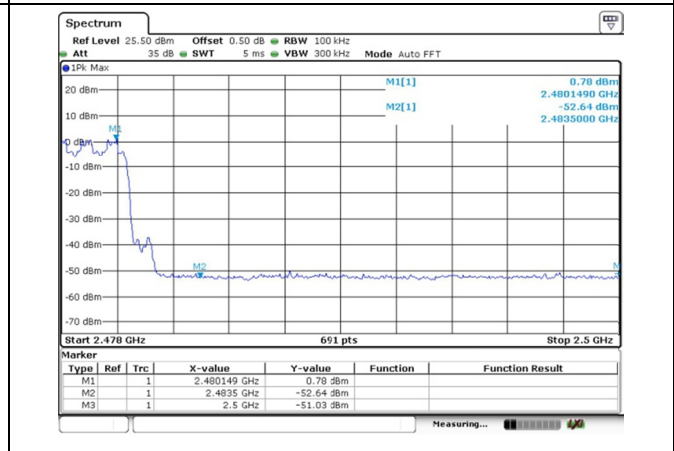

Bandedge- hopping mode (CH78)

8DPSK Tx Spurious Emission

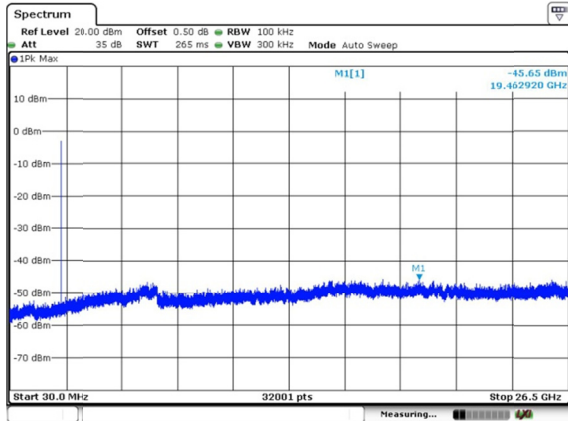

CH00

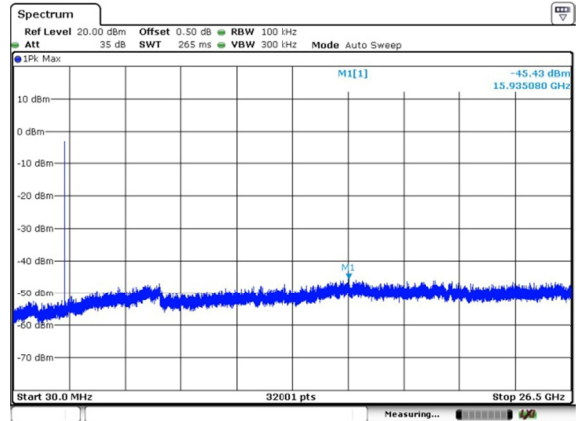

CH39

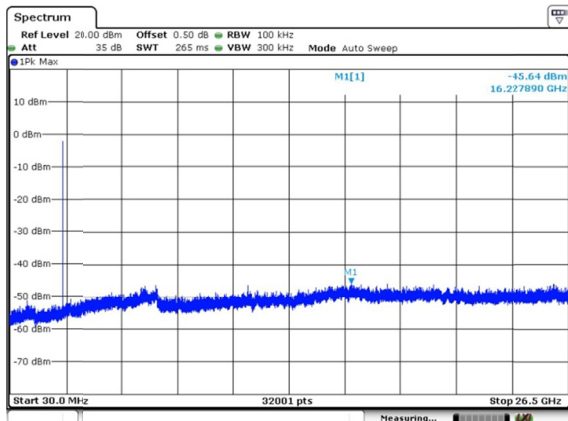

CH78

4.11. Spurious Emission (radiated)

LIMIT

FCC CFR Title 47 Part 15 Subpart C Section 15.209

Frequency	Limit (dBuV/m @3m)	Value
30MHz-88MHz	40.00	Quasi-peak
88MHz-216MHz	43.50	Quasi-peak
216MHz-960MHz	46.00	Quasi-peak
960MHz-1GHz	54.00	Quasi-peak
Above 1GHz	54.00	Average
	74.00	Peak

TEST CONFIGURATION

- ◆ Below 30MHz

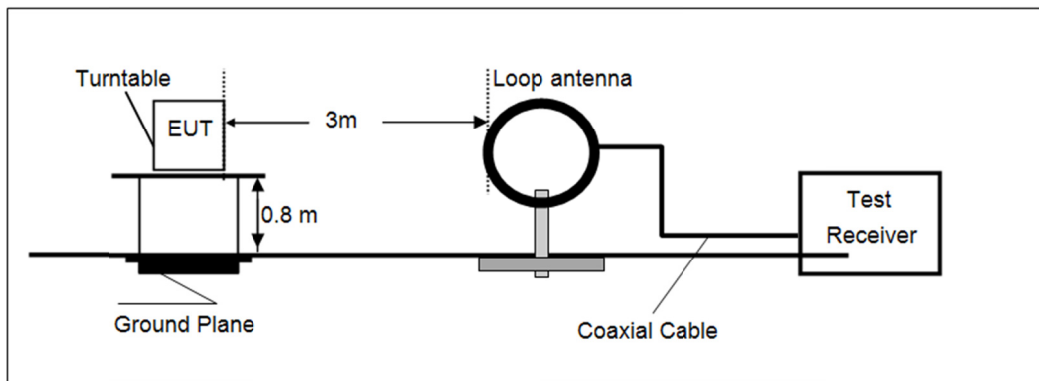

- ◆ 30MHz~1000MHz

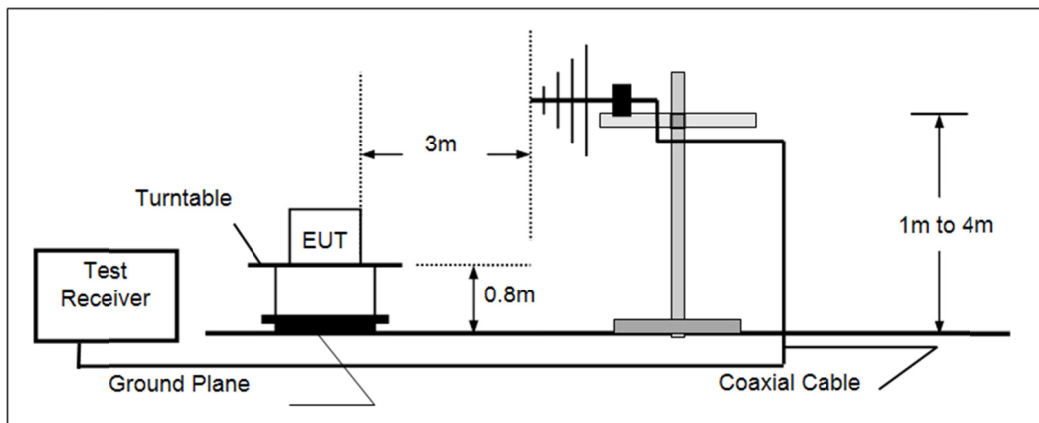

- ◆ Above 1GHz

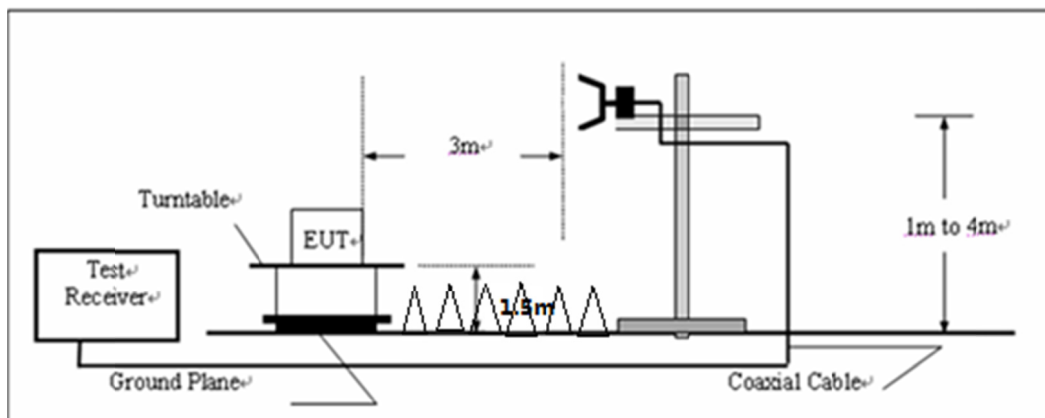

TEST PROCEDURE

1. The EUT was placed on the top of a rotating table 0.8 meter above ground for below 1GHz, and 1.5m for above 1GHz at a 3 meter camber. The table was rotated 360 degrees to determine the position of the highest radiation.
2. The EUT was set 3 meters away from the interference-receiving antenna, which was mounted on the top of a variable-height antenna tower.
3. The antenna height is varied from one meter to four meters above the ground to determine the maximum value of the field strength. Both horizontal and vertical polarizations of the antenna are set to make the measurement.
4. For each suspected emission, the EUT was arranged to its worst case and then the antenna was tuned to heights from 1 meter to 4 meters and the rotating table was turned from 0 degrees to 360 degrees to find the maximum reading.
5. Use the following spectrum analyzer settings
 - a) Span shall wide enough to fully capture the emission being measured;
 - b) Below 1GHz, RBW=120KHz, VBW=300KHz, Sweep=auto, Detector function=peak, Trace=max hold;
If the emission level of the EUT measured by the peak detector is 3 dB lower than the applicable limit, the peak emission level will be reported. Otherwise, the emission measurement will be repeated using the quasi-peak detector and reported.
 - c) Above 1GHz, RBW=1MHz, VBW=3MHz for Peak value
RBW=1MHz, VBW=10Hz for Average value.

TEST RESULTS

Noted:

Below 1GHz

Have pre-scan all modulation mode, found the GFSK modulation CH39 which it was worst case, so only the worst case's data on the test report.

Above 1GHz

Have pre-scan all modulation mode, found the GFSK modulation which it was worst case, so only the worst case's data on the test report.

Measurement data:

■ 9kHz ~ 30MHz

The low frequency, which started from 9 kHz to 30MHz, was pre-scanned and the result which was 20dB lower than the limit line per 15.31(o) was not reported.

■ 30MHz ~ 1GHz

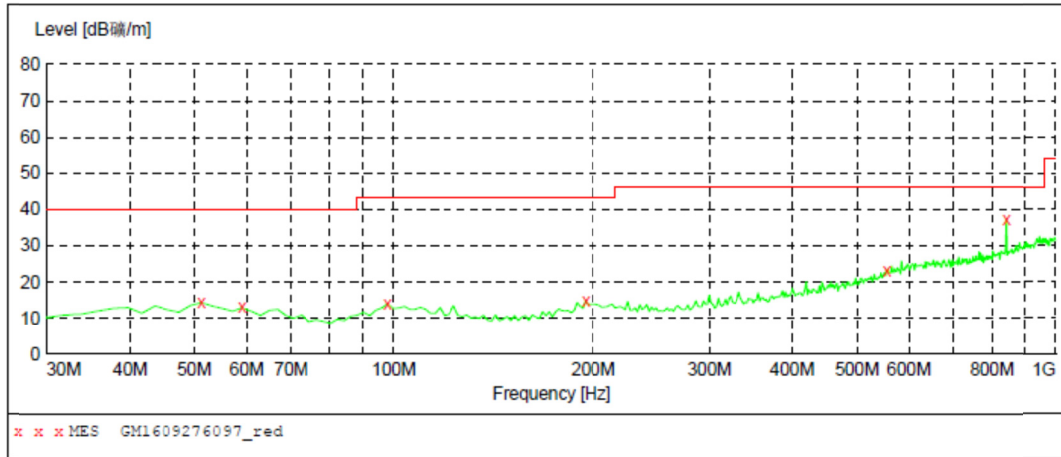

MEASUREMENT RESULT: "GM1609276097_red"

9/27/2016 8:59PM

Frequency MHz	Level dB/m	Transd dB	Limit dB/m	Margin dB	Det.	Height cm	Azimuth deg	Polarization
51.340000	14.40	-14.4	40.0	25.6	QP	100.0	359.00	HORIZONTAL
59.100000	13.00	-14.8	40.0	27.0	QP	300.0	18.00	HORIZONTAL
97.900000	14.10	-14.7	43.5	29.4	QP	300.0	311.00	HORIZONTAL
194.900000	14.90	-14.1	43.5	28.6	QP	100.0	27.00	HORIZONTAL
555.740000	23.30	-4.6	46.0	22.7	QP	100.0	96.00	HORIZONTAL
840.920000	37.20	1.3	46.0	8.8	QP	100.0	359.00	HORIZONTAL

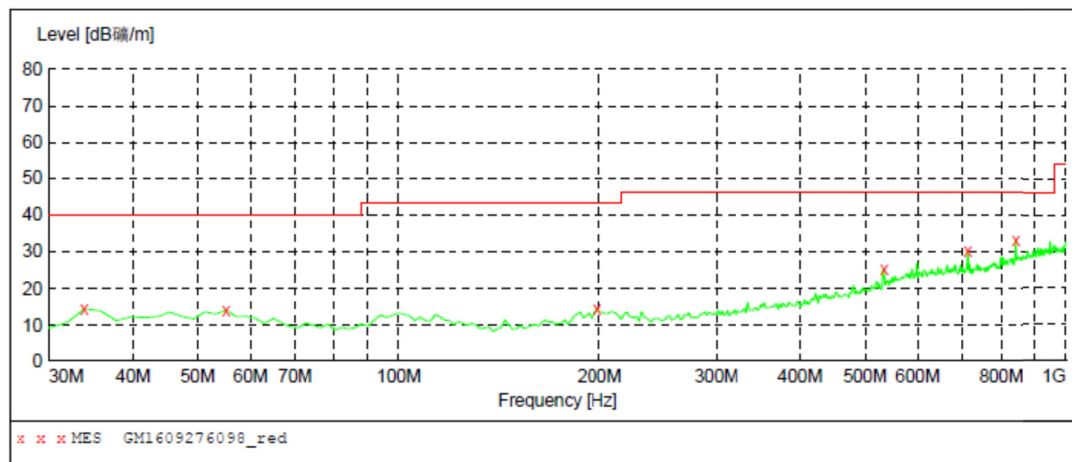

MEASUREMENT RESULT: "GM1609276098_red"

9/27/2016 9:02PM

Frequency MHz	Level dB/m	Transd dB	Limit dB/m	Margin dB	Det.	Height cm	Azimuth deg	Polarization
33.880000	14.50	-16.2	40.0	25.5	QP	100.0	0.00	VERTICAL
55.220000	14.20	-14.6	40.0	25.8	QP	100.0	321.00	VERTICAL
198.780000	14.30	-13.7	43.5	29.2	QP	100.0	6.00	VERTICAL
534.400000	25.10	-5.6	46.0	20.9	QP	100.0	178.00	VERTICAL
712.880000	30.20	-1.5	46.0	15.8	QP	100.0	178.00	VERTICAL
840.920000	33.00	1.3	46.0	13.0	QP	100.0	354.00	VERTICAL

Remark: Transd=Cable lose+ Antenna factor- Pre-amplifier; Margin=Limit -Level

■ Above 1GHz

CH00 for GFSK									
Frequency (MHz)	Read Level (dBuV)	Antenna Factor (dB/m)	Cable Loss (dB)	Preamp Factor (dB)	Level (dBuV/m)	Limit Line (dBuV/m)	Margin Limit (dB)	Polarization	Test value
4804.00	43.00	31.28	5.66	35.29	44.65	74.00	-29.35	Vertical	Peak
7206.00	35.40	36.22	6.87	35.15	43.34	74.00	-30.66	Vertical	
9608.00	35.48	37.85	8.80	35.55	46.58	74.00	-27.42	Vertical	
11264.26	*							Vertical	
4804.00	44.20	31.28	5.66	35.29	45.85	74.00	-28.15	Horizontal	
7206.00	34.81	36.22	6.87	35.15	42.75	74.00	-31.25	Horizontal	
9608.00	35.28	37.85	8.80	35.55	46.38	74.00	-27.62	Horizontal	
11264.26	*							Horizontal	
4804.00	36.82	31.28	5.66	35.29	38.47	54.00	-15.53	Vertical	Average
7206.00	29.64	36.22	6.87	35.15	37.58	54.00	-16.42	Vertical	
9608.00	29.15	37.85	8.80	35.55	40.25	54.00	-13.75	Vertical	
11264.26	*							Vertical	
4804.00	38.93	31.28	5.66	35.29	40.58	54.00	-13.42	Horizontal	
7206.00	29.90	36.22	6.87	35.15	37.84	54.00	-16.16	Horizontal	
9608.00	29.34	37.85	8.80	35.55	40.44	54.00	-13.56	Horizontal	
11264.26	*							Horizontal	

CH39 for GFSK									
Frequency (MHz)	Read Level (dBuV)	Antenna Factor (dB/m)	Cable Loss (dB)	Preamp Factor (dB)	Level (dBuV/m)	Limit Line (dBuV/m)	Margin Limit (dB)	Polarization	Test value
4882.00	42.16	30.88	5.70	35.27	43.47	74.00	-30.53	Vertical	Peak
7323.00	36.25	35.82	6.91	35.13	43.85	74.00	-30.15	Vertical	
9764.00	35.32	37.45	8.84	35.53	46.08	74.00	-27.92	Vertical	
12247.62	*							Vertical	
4882.00	43.21	30.88	5.70	35.27	44.52	74.00	-29.48	Horizontal	
7323.00	35.15	35.82	6.91	35.13	42.75	74.00	-31.25	Horizontal	
9764.00	35.30	37.45	8.84	35.53	46.06	74.00	-27.94	Horizontal	
12247.62	*							Horizontal	
4882.00	36.63	30.88	5.70	35.27	37.94	54.00	-16.06	Vertical	Average
7323.00	29.65	35.82	6.91	35.13	37.25	54.00	-16.75	Vertical	
9764.00	29.89	37.45	8.84	35.53	40.65	54.00	-13.35	Vertical	
12247.62	*							Vertical	
4882.00	38.55	30.88	5.70	35.27	39.86	54.00	-14.14	Horizontal	
7323.00	29.92	35.82	6.91	35.13	37.52	54.00	-16.48	Horizontal	
9764.00	29.76	37.45	8.84	35.53	40.52	54.00	-13.48	Horizontal	
12247.62	*							Horizontal	

Remark:

1. Final Level = Receiver Read level + Antenna Factor + Cable Loss – Preamplifier Factor
2. “*”, means this data is the too weak instrument of signal is unable to test.
3. The emission levels of other frequencies are very lower than the limit and not show in test report.

CH78 for GFSK									
Frequency (MHz)	Read Level (dBuV)	Antenna Factor (dB/m)	Cable Loss (dB)	Preamp Factor (dB)	Level (dBuV/m)	Limit Line (dBuV/m)	Margin Limit (dB)	Polarization	Test value
4960.00	42.66	30.98	5.73	35.32	44.05	74.00	-29.95	Vertical	Peak
7440.00	35.79	35.92	6.94	35.18	43.47	74.00	-30.53	Vertical	
9920.00	35.05	37.55	8.87	35.58	45.89	74.00	-28.11	Vertical	
13214.26	*							Vertical	
4960.00	43.67	30.98	5.73	35.32	45.06	74.00	-28.94	Horizontal	
7440.00	34.84	35.92	6.94	35.18	42.52	74.00	-31.48	Horizontal	
9920.00	35.30	37.55	8.87	35.58	46.14	74.00	-27.86	Horizontal	
13214.26	*							Horizontal	
4960.00	38.39	30.98	5.73	35.32	39.78	54.00	-14.22	Vertical	Average
7440.00	30.17	35.92	6.94	35.18	37.85	54.00	-16.15	Vertical	
9920.00	29.41	37.55	8.87	35.58	40.25	54.00	-13.75	Vertical	
13214.26	*							Vertical	
4960.00	38.76	30.98	5.73	35.32	40.15	54.00	-13.85	Horizontal	
7440.00	29.68	35.92	6.94	35.18	37.36	54.00	-16.64	Horizontal	
9920.00	29.68	37.55	8.87	35.58	40.52	54.00	-13.48	Horizontal	
13214.26	*							Horizontal	

Remark:

1. Final Level = Receiver Read level + Antenna Factor + Cable Loss – Pre-amplifier Factor
2. “*”, means this data is the too weak instrument of signal is unable to test.
3. The emission levels of other frequencies are very lower than the limit and not show in test report.

5. Test Setup Photos of the EUT

Radiated Emission

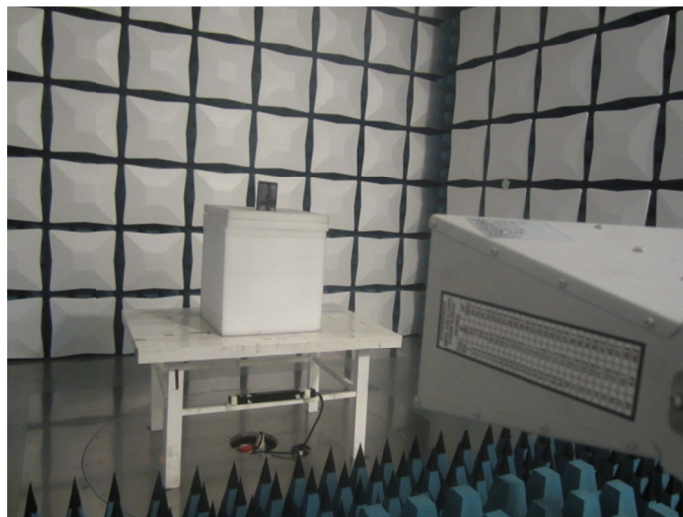
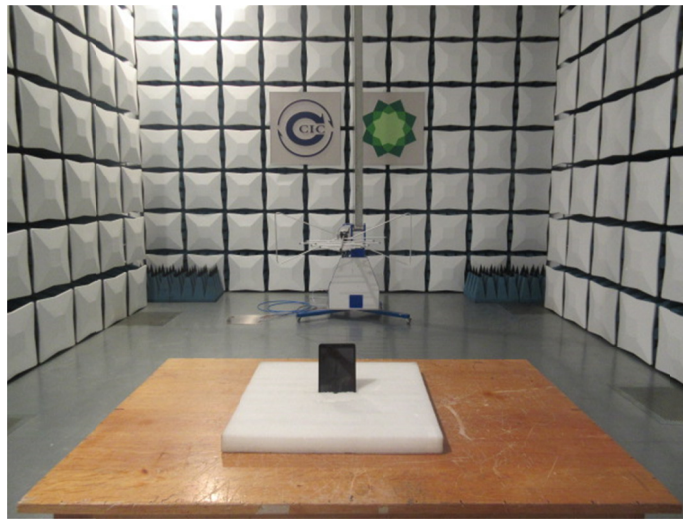

Conducted Emission (AC Mains)



6. External and Internal Photos of the EUT

Reference to Test Report No.: TRE1609005901.

.....*End of Report*.....