



# TEST REPORT

**Report Reference No.**..... : **TRE1809007008** R/C.....: 84875

**FCC ID**..... : **2AJZP-D450B**

**Applicant's name**..... : **Mason America, Inc.**

Address..... : 506 2nd Ave, Suite 1400 Seattle, WA 98104, United States

Manufacturer..... : Mason America, Inc.

Address..... : 506 2nd Ave, Suite 1400 Seattle, WA 98104, United States

**Test item description** ..... : **Mobile phone**

Trade Mark ..... : MASON

Model/Type reference..... : D450B

Listed Model(s) ..... : -

**Standard** ..... : **FCC CFR Title 47 Part 15 Subpart C Section 15.225**

Date of receipt of test sample..... : Sep 17,2018

Date of testing..... : Sep 18,2018-Oct 08,2018

Date of issue..... : Oct 09,2018

**Result**..... : **PASS**

Compiled by  
( position+printedname+signature)....: File administrators Silvia Li

*Silvia Li*

Supervised by  
(position+printedname+signature).....: Project Engineer Aaron Fang

*Aaron.Fang*

Approved by  
(position+printedname+signature).....: RF Manager Hans Hu

*Hans Hu*

**Testing Laboratory Name** ..... : **Shenzhen Huatongwei International Inspection Co., Ltd.**

Address..... : 1/F, Bldg 3, Hongfa Hi-tech Industrial Park, Genyu Road, Tianliao, Gongming, Shenzhen, China

**Shenzhen Huatongwei International Inspection Co., Ltd. All rights reserved.**

This publication may be reproduced in whole or in part for non-commercial purposes as long as the Shenzhen Huatongwei International Inspection Co., Ltd. is acknowledged as copyright owner and source of the material. Shenzhen Huatongwei International Inspection Co., Ltd. takes no responsibility for and will not assume liability for damages resulting from the reader's interpretation of the reproduced material due to its placement and context.

*The test report merely correspond to the test sample.*

## Contents

|           |   |           |
|-----------|---|-----------|
| <b>1.</b> | <b><u>TEST STANDARDS AND REPORT VERSION</u></b>       | <b>3</b>  |
| 1.1.      | Test Standards  | 3         |
| 1.2.      | Report version information                            | 3         |
| <b>2.</b> | <b><u>TEST DESCRIPTION</u></b>                        | <b>4</b>  |
| <b>3.</b> | <b><u>SUMMARY</u></b>                                 | <b>5</b>  |
| 3.1.      | Client Information                                    | 5         |
| 3.2.      | Product Description                                   | 5         |
| 3.3.      | EUT operation mode                                    | 6         |
| 3.4.      | EUT configuration                                     | 6         |
| <b>4.</b> | <b><u>TEST ENVIRONMENT</u></b>                        | <b>7</b>  |
| 4.1.      | Address of the test laboratory                        | 7         |
| 4.2.      | Test Facility   | 7         |
| 4.3.      | Environmental conditions                              | 8         |
| 4.4.      | Statement of the measurement uncertainty              | 8         |
| 4.5.      | Equipments Used during the Test                       | 9         |
| <b>5.</b> | <b><u>TEST CONDITIONS AND RESULTS</u></b>             | <b>10</b> |
| 5.1.      | Antenna requirement                                   | 10        |
| 5.2.      | Restricted Bands of Operation                         | 11        |
| 5.3.      | AC Power Conducted Emissions                          | 12        |
| 5.4.      | Radiated Emission                                     | 15        |
| 5.5.      | 20 dB Occupied Bandwidth                              | 18        |
| 5.6.      | Radiated field strength of the fundamental signal     | 19        |
| 5.7.      | Out of Band Emission                                  | 21        |
| 5.8.      | Frequency Stability                                   | 23        |
| <b>6.</b> | <b><u>TEST SETUP PHOTOS OF THE EUT</u></b>            | <b>24</b> |
| <b>7.</b> | <b><u>EXTERNAL AND INTERNAL PHOTOS OF THE EUT</u></b> | <b>24</b> |

## 1. TEST STANDARDS AND REPORT VERSION

### 1.1. Test Standards

The tests were performed according to following standards:

[FCC Rules Part 15.225](#): Operation within the band 13.110-14.010 MHz.

[ANSI C63.10-2013](#): American National Standard for Testing Unlicensed Wireless Devices.

### 1.2. Report version information

| Revision No. | Date of issue | Description |
|--------------|---------------|-------------|
| N/A          | 2018-10-09    | Original    |
|              |               |             |
|              |               |             |
|              |               |             |
|              |               |             |

## 2. TEST DESCRIPTION

| Test Item                                | Section in CFR 47 | Result | Test Engineer |
|--|-------------------|--------|---------------|
| Antenna requirement                      | 15.203            | PASS   | Xiaokang Tan  |
| Restricted Band of operation             | 15.205            | PASS   | Xiaokang Tan  |
| AC Power Line Conducted Emissions        | 15.207            | N/A    | N/A           |
| Radiated Emissions                       | 15.209            | PASS   | Michael Jie   |
| 20dB Occupied Bandwidth                  | 15.215            | PASS   | Xiaokang Tan  |
| Field Strength of the Fundamental Signal | 15.225(a)         | PASS   | Shower Dai    |
| Out of Band Emission                     | 15.225(b)(c)      | PASS   | Shower Dai    |
| Frequency Stability                      | 15.225(e)         | PASS   | Xiaokang Tan  |

Remark: N/A: not applicable

### 3. SUMMARY

#### 3.1. Client Information

|               |  |
|---------------|--|
| Applicant:    | Mason America, Inc.                                      |
| Address:      | 506 2nd Ave, Suite 1400 Seattle, WA 98104, United States |
| Manufacturer: | Mason America, Inc.                                      |
| Address:      | 506 2nd Ave, Suite 1400 Seattle, WA 98104, United States |

#### 3.2. Product Description

|                         |   |
|-------------------------|---|
| Name of EUT:            | Mobile phone  |
| Trade Mark:             | MASON   |
| Model No.:              | D450B   |
| Listed Model(s):        | -   |
| Power supply*:          | DC 3.85V  |
| Adapter information:    | Model:TPA-10120150UU<br>Input:100-240Va.c. 50-60Hz 0.6A<br>Output:5.0Vd.c. 3A |
| <b>RF Specification</b> |   |
| Operation frequency:    | 13.56MHz  |
| Channel number:         | 1   |
| Modulation Type:        | ASK   |
| Antenna type:           | Integral Antenna  |
| Antenna gain:           | 0dBi  |

### 3.3. EUT operation mode

#### TEST MODE

|  |
|--|
| For RF test items  |
| The engineering test program was provided and enabled to make EUT continuous transmit. |
| For AC power line conducted emissions:   |
| The EUT was set to connect with large package sizes transmission.                      |

### 3.4. EUT configuration

The following peripheral devices and interface cables were connected during the measurement:

- - supplied by the manufacturer
- - supplied by the lab

|  |                |   |
|--|----------------|---|
|  | Manufacturer : | / |
|  | Model No. :    | / |
|  | Manufacturer : | / |
|  | Model No. :    | / |

## **4. TEST ENVIRONMENT**

### **4.1. Address of the test laboratory**

Laboratory: Shenzhen Huatongwei International Inspection Co., Ltd.

Address: 1/F, Bldg 3, Hongfa Hi-tech Industrial Park, Genyu Road, Tianliao, Gongming, Shenzhen, China

Phone: 86-755-26748019 Fax: 86-755-26748089

### **4.2. Test Facility**

The test facility is recognized, certified, or accredited by the following organizations:

#### **CNAS-Lab Code: L1225**

Shenzhen Huatongwei International Inspection Co., Ltd. has been assessed and proved to be in compliance with CNAS-CL01 Accreditation Criteria for Testing and Calibration Laboratories (identical to ISO/IEC17025: 2005 General Requirements) for the Competence of Testing and Calibration Laboratories.

#### **A2LA-Lab Cert. No. 3902.01**

Shenzhen Huatongwei International Inspection Co., Ltd. EMC Laboratory has been accredited by A2LA for technical competence in the field of electrical testing, and proved to be in compliance with ISO/IEC 17025: 2005 General Requirements for the Competence of Testing and Calibration Laboratories and any additional program requirements in the identified field of testing.

#### **FCC-Registration No.: 762235**

Shenzhen Huatongwei International Inspection Co., Ltd. EMC Laboratory has been registered and fully described in a report filed with the FCC (Federal Communications Commission). The acceptance letter from the FCC is maintained in our files. Registration 762235.

#### **IC-Registration No.: 5377B-1**

Two 3m Alternate Test Site of Shenzhen Huatongwei International Inspection Co., Ltd. has been registered by Certification and Engineering Bureau of Industry Canada for the performance of radiated measurements with Registration No. 5377B-1.

#### **ACA**

Shenzhen Huatongwei International Inspection Co., Ltd. EMC Laboratory can also perform testing for the Australian C-Tick mark as a result of our A2LA accreditation.

### 4.3. Environmental conditions

During the measurement the environmental conditions were within the listed ranges:

|                    |             |
|--------------------|-------------|
| Temperature:       | 15~35°C     |
| Relative Humidity: | 30~60 %     |
| Air Pressure:      | 950~1050mba |

### 4.4. Statement of the measurement uncertainty

The data and results referenced in this document are true and accurate. The reader is cautioned that there may be errors in calibration limits of the equipment and facilities. The measurement uncertainty was calculated for all measurements listed in this test report according to TR-100028-01 "Electromagnetic compatibility and Radio spectrum Matters (ERM);Uncertainties in the measurement of mobile radio equipment characteristics;Part 1" and TR-100028-02 "Electromagnetic compatibility and Radio spectrum Matters (ERM);Uncertainties in the measurementof mobile radio equipment characteristics;Part 2" and is documented in the Shenzhen Huatongwei International Inspection Co., Ltd quality system according to ISO/IEC 17025. Further more, component and process variability of devices similar to that tested may result in additional deviation. The manufacturer has the sole responsibility of continued compliance of the device.

Here after the best measurement capability for Shenzhen Huatongwei is reported:

| Test Items                              | Measurement Uncertainty | Notes |
|---|-------------------------|-------|
| Conducted spurious emissions 9KHz-30MHz | 3.39 dB                 | (1)   |
| Radiated Emissions 30~1000MHz           | 4.24 dB                 | (1)   |
| Radiated Emissions 1~18GHz              | 5.16 dB                 | (1)   |
| Radiated Emissions 18-40GHz             | 5.54 dB                 | (1)   |
| Occupied Bandwidth                      | -----                   | (1)   |

(1) This uncertainty represents an expanded uncertainty expressed at approximately the 95% confidence level using a coverage factor of k=1.96.



**4.5. Equipments Used during the Test**

| <b>Conducted Emissions</b> |                         |                    |              |             |                      |                      |
|----------------------------|-------------------------|--------------------|--------------|-------------|----------------------|----------------------|
| Item                       | Test Equipment          | Manufacturer       | Model No.    | Serial No.  | Last Cal. (mm-dd-yy) | Next Cal. (mm-dd-yy) |
| 1                          | EMI Test Receiver       | R&S                | ESCI         | 101247      | 11/11/2017           | 11/10/2018           |
| 2                          | Artificial Mains        | SCHWARZBECK        | NNLK 8121    | 573         | 11/11/2017           | 11/10/2018           |
| 3                          | 2-Line V-Network        | R&S                | ESH3-Z5      | 100049      | 11/11/2017           | 11/10/2018           |
| 4                          | Pulse Limiter           | R&S                | ESH3-Z2      | 101488      | 11/11/2017           | 11/10/2018           |
| 5                          | RF Connection Cable     | HUBER+SUHNER       | EF400        | N/A         | 11/21/2017           | 11/20/2018           |
| 6                          | Test Software           | R&S                | ES-K1        | N/A         | N/A                  | N/A                  |
| <b>Radiated Emissions</b>  |                         |                    |              |             |                      |                      |
| Item                       | Test Equipment          | Manufacturer       | Model No.    | Serial No.  | Last Cal. (mm-dd-yy) | Next Cal. (mm-dd-yy) |
| 1                          | Semi-Anechoic Chamber   | Albatross projects | SAC-3m-01    | C11121      | 10/16/2016           | 10/15/2019           |
| 2                          | EMI Test Receiver       | R&S                | ESCI         | 100900      | 11/11/2017           | 11/10/2018           |
| 3                          | Loop Antenna            | R&S                | HFH2-Z2      | 100020      | 11/20/2017           | 11/19/2020           |
| 4                          | Ultra-Broadband Antenna | SCHWARZBECK        | VULB9163     | 538         | 4/5/2017             | 4/4/2020             |
| 5                          | Horn Antenna            | SCHWARZBECK        | 9120D        | 1011        | 3/27/2017            | 3/26/2020            |
| 6                          | Broadband Horn Antenna  | SCHWARZBECK        | BBHA9170     | BBHA9170472 | 3/27/2017            | 3/26/2020            |
| 7                          | Pre-amplifier           | SCHWARZBECK        | BBV 9743     | 9743-0022   | 10/18/2017           | 10/17/2018           |
| 8                          | Broadband Pre-amplifier | SCHWARZBECK        | BBV 9718     | 9718-248    | 10/18/2017           | 10/17/2018           |
| 9                          | Spectrum Analyzer       | R&S                | FSP40        | 100597      | 11/11/2017           | 11/10/2018           |
| 10                         | RF Connection Cable     | HUBER+SUHNER       | RE-7-FL      | N/A         | 11/21/2017           | 11/20/2018           |
| 12                         | Test Software           | Audix              | E3           | N/A         | N/A                  | N/A                  |
| 13                         | Test Software           | R&S                | ES-K1        | N/A         | N/A                  | N/A                  |
| 14                         | Turntable               | Maturo Germany     | TT2.0-1T     | N/A         | N/A                  | N/A                  |
| 15                         | Antenna Mast            | Maturo Germany     | CAM-4.0-P-12 | N/A         | N/A                  | N/A                  |
| <b>RF Conducted Test</b>   |                         |                    |              |             |                      |                      |
| Item                       | Test Equipment          | Manufacturer       | Model No.    | Serial No.  | Last Cal. (mm-dd-yy) | Next Cal. (mm-dd-yy) |
| 1                          | Spectrum Analyzer       | R&S                | FSV40        | 100048      | 11/11/2017           | 11/10/2018           |

## 5. TEST CONDITIONS AND RESULTS

### 5.1. Antenna requirement

#### Requirement

##### **FCC CFR Title 47 Part 15 Subpart C Section 15.203:**

An intentional radiator shall be designed to ensure that no antenna other than that furnished by the responsible party shall be used with the device. The use of a permanently attached antenna or of an antenna that uses a unique coupling to the intentional radiator, the manufacturer may design the unit so that a broken antenna can be replaced by the user, but the use of a standard antenna jack or electrical connector is prohibited.

#### **Refer to statement below for compliance.**

The manufacturer may design the unit so that the user can replace a broken antenna, but the use of a standard antenna jack or electrical connector is prohibited. Further, this requirement does not apply to intentional radiators that must be professionally installed.

#### TEST RESULTS

Passed       Not Applicable

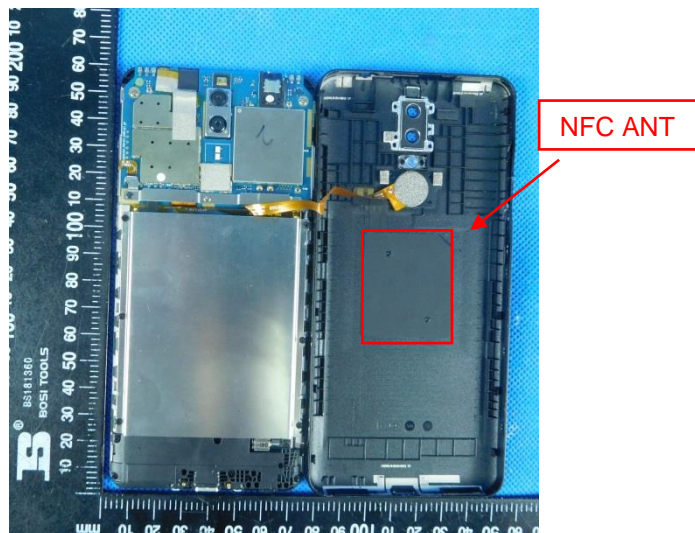

### 5.2. Restricted Bands of Operation

#### Requirement

Only spurious emissions are permitted in any of the frequency bands listed below :

| MHz                      | MHz                 | MHz           | GHz              |
|--------------------------|---------------------|---------------|------------------|
| 0.090-0.110              | 16.42-16.423        | 399.9-410     | 4.5-5.15         |
| <sup>1</sup> 0.495-0.505 | 16.69475-16.69525   | 608-614       | 5.35-5.46        |
| 2.1735-2.1905            | 16.80425-16.80475   | 960-1240      | 7.25-7.75        |
| 4.125-4.128              | 25.5-25.67          | 1300-1427     | 8.025-8.5        |
| 4.17725-4.17775          | 37.5-38.25          | 1435-1626.5   | 9.0-9.2          |
| 4.20725-4.20775          | 73-74.6             | 1645.5-1646.5 | 9.3-9.5          |
| 6.215-6.218              | 74.8-75.2           | 1660-1710     | 10.6-12.7        |
| 6.26775-6.26825          | 108-121.94          | 1718.8-1722.2 | 13.25-13.4       |
| 6.31175-6.31225          | 123-138             | 2200-2300     | 14.47-14.5       |
| 8.291-8.294              | 149.9-150.05        | 2310-2390     | 15.35-16.2       |
| 8.362-8.366              | 156.52475-156.52525 | 2483.5-2500   | 17.7-21.4        |
| 8.37625-8.38675          | 156.7-156.9         | 2690-2900     | 22.01-23.12      |
| 8.41425-8.41475          | 162.0125-167.17     | 3260-3267     | 23.6-24.0        |
| 12.29-12.293             | 167.72-173.2        | 3332-3339     | 31.2-31.8        |
| 12.51975-12.52025        | 240-285             | 3345.8-3358   | 36.43-36.5       |
| 12.57675-12.57725        | 322-335.4           | 3600-4400     | ( <sup>2</sup> ) |
| 13.36-13.41              |                     |               |                  |

<sup>1</sup>Until February 1, 1999, this restricted band shall be 0.490-0.510 MHz.

#### TEST RESULTS

Passed       Not Applicable

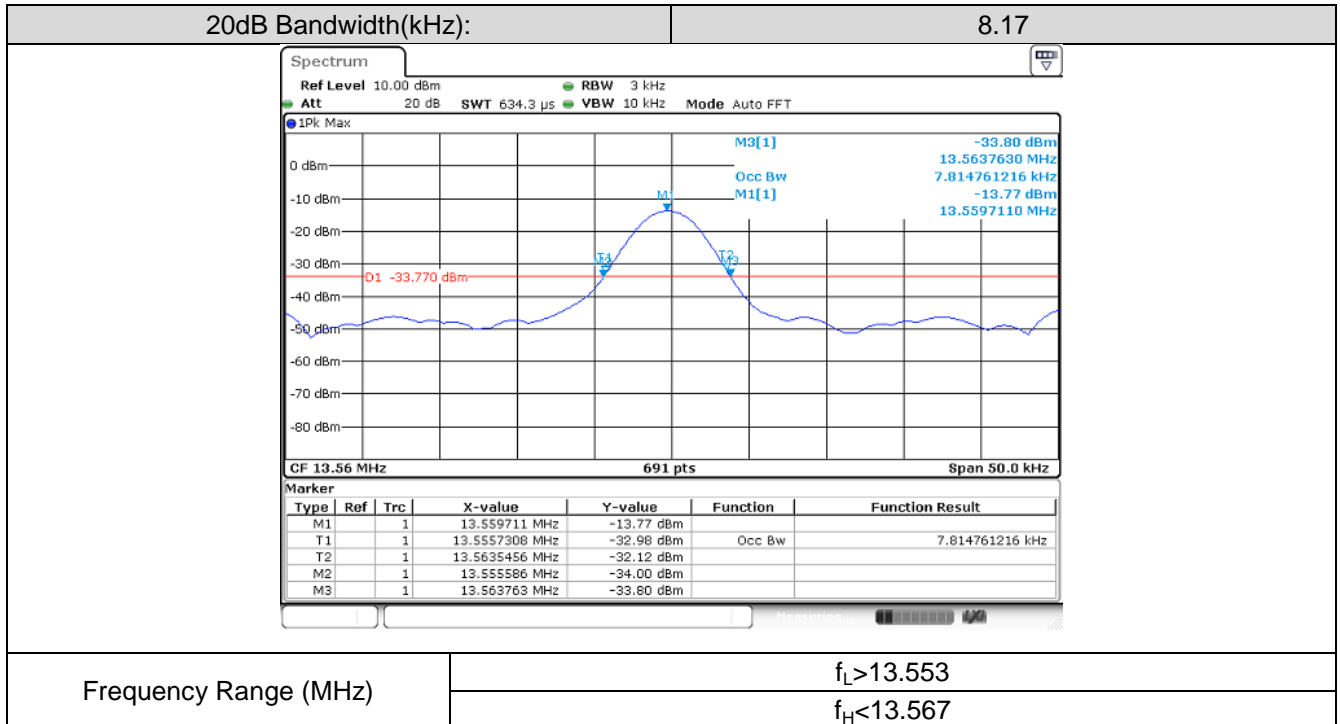

### 5.3. AC Power Conducted Emissions

#### LIMIT

FCC CFR Title 47 Part 15 Subpart C Section 15.207:

| Frequency range (MHz) | Limit (dBuV) |           |
|-----------------------|--------------|-----------|
|                       | Quasi-peak   | Average   |
| 0.15-0.5              | 66 to 56*    | 56 to 46* |
| 0.5-5                 | 56           | 46        |
| 5-30                  | 60           | 50        |

\* Decreases with the logarithm of the frequency.

#### TEST CONFIGURATION

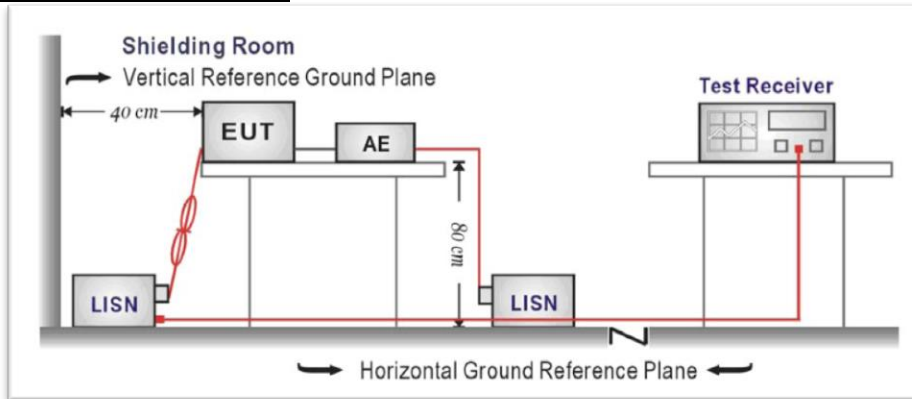

#### TEST PROCEDURE

1. The EUT was setup according to ANSI C63.10:2013
2. The EUT was placed on a plat form of nominal size, 1 m by 1.5 m, raised 10 cm above the conducting ground plane. The vertical conducting plane was located 40 cm to the rear of the EUT. All other surfaces of EUT were at least 10 cm from any other grounded conducting surface.
3. The EUT and simulators are connected to the main power through a line impedance stabilization network (LISN). The LISN provides a 50ohm / 50uH coupling impedance for the measuring equipment.
4. The peripheral devices are also connected to the main power through a LISN. (Please refer to the block diagram of the test setup and photographs)
5. Each current-carrying conductor of the EUT power cord, except the ground (safety) conductor, was individually connected through a LISN to the input power source.
6. The excess length of the power cord between the EUT and the LISN receptacle were folded back and forth at the center of the lead to form a bundle not exceeding 40 cm in length.
7. Conducted emissions were investigated over the frequency range from 0.15MHz to 30MHz using a receiver bandwidth of 9 kHz.
8. During the above scans, the emissions were maximized by cable manipulation.

#### TEST MODE:

Please refer to the clause 3.3

#### TEST RESULTS

Passed       Not Applicable

Test Line: L

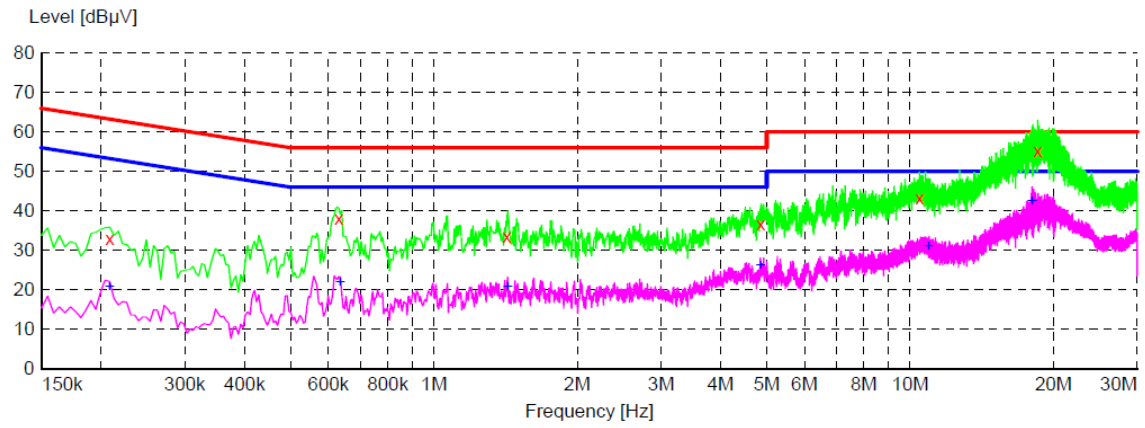

x x x MES GM1809215021\_fin

**MEASUREMENT RESULT: "GM1809215021\_fin"**

9/21/2018 10:15AM

| Frequency<br>MHz | Level<br>dBµV | Transd<br>dB | Limit<br>dBµV | Margin<br>dB | Detector | Line | PE  |
|------------------|---------------|--------------|---------------|--------------|----------|------|-----|
| 0.208500         | 33.00         | 10.2         | 63            | 30.3         | QP       | L1   | GND |
| 0.631500         | 38.00         | 10.0         | 56            | 18.0         | QP       | L1   | GND |
| 1.423500         | 33.50         | 10.0         | 56            | 22.5         | QP       | L1   | GND |
| 4.857000         | 36.50         | 10.1         | 56            | 19.5         | QP       | L1   | GND |
| 10.473000        | 43.30         | 10.2         | 60            | 16.7         | QP       | L1   | GND |
| 18.537000        | 55.30         | 10.3         | 60            | 4.7          | QP       | L1   | GND |

**MEASUREMENT RESULT: "GM1809215021\_fin2"**

9/21/2018 10:15AM

| Frequency<br>MHz | Level<br>dBµV | Transd<br>dB | Limit<br>dBµV | Margin<br>dB | Detector | Line | PE  |
|------------------|---------------|--------------|---------------|--------------|----------|------|-----|
| 0.208500         | 20.80         | 10.2         | 53            | 32.5         | AV       | L1   | GND |
| 0.636000         | 21.90         | 10.0         | 46            | 24.1         | AV       | L1   | GND |
| 1.428000         | 20.60         | 10.0         | 46            | 25.4         | AV       | L1   | GND |
| 4.852500         | 26.20         | 10.1         | 46            | 19.8         | AV       | L1   | GND |
| 10.941000        | 31.10         | 10.2         | 50            | 18.9         | AV       | L1   | GND |
| 18.046500        | 42.30         | 10.3         | 50            | 7.7          | AV       | L1   | GND |

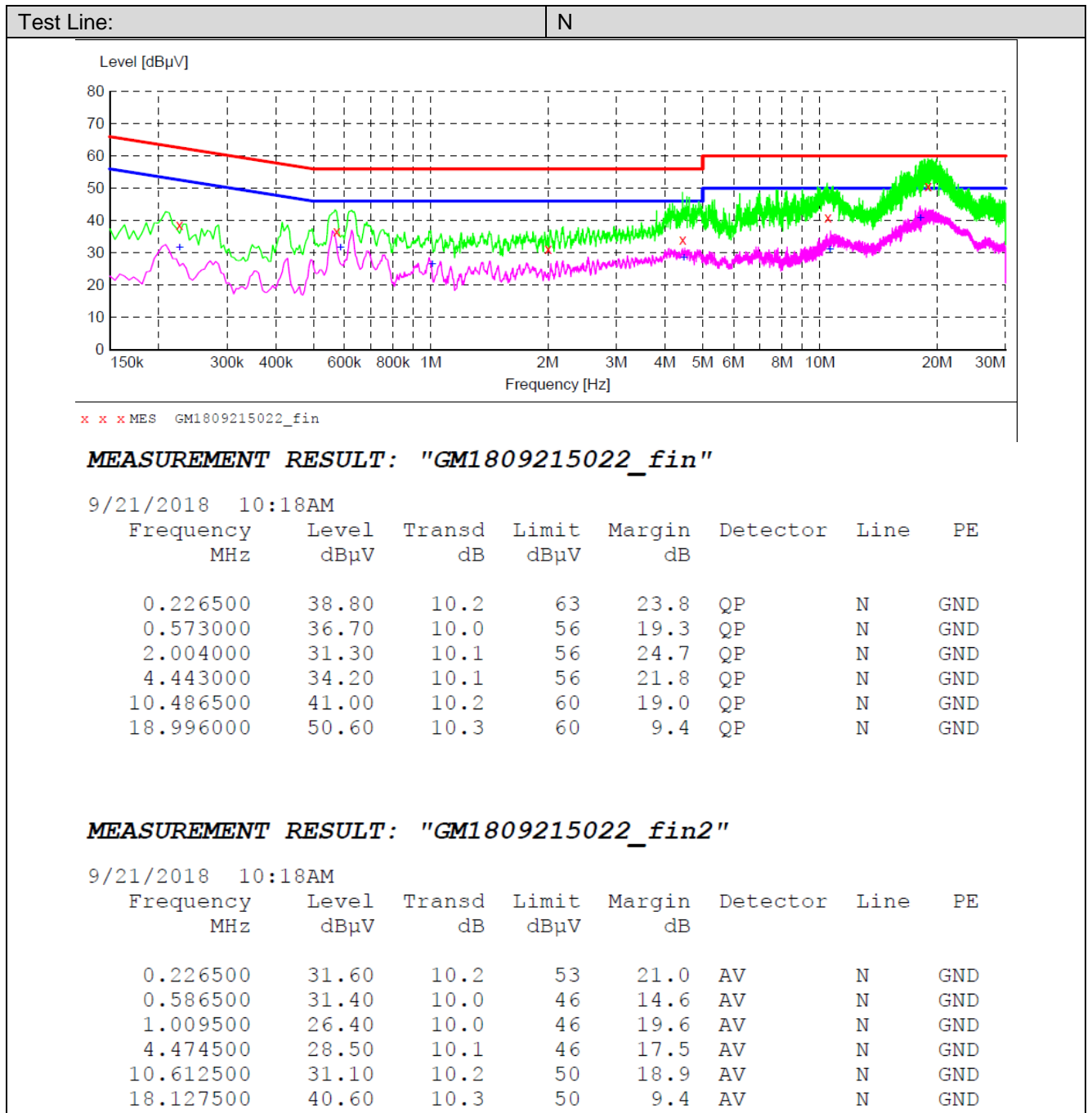

### 5.4. Radiated Emission

**LIMIT**

**FCC CFR Title 47 Part 15 Subpart C Section 15.209**

| Frequency     | Limit (dBuV/m @3m) | Value      |
|---------------|--------------------|------------|
| 30MHz~88MHz   | 40.00              | Quasi-peak |
| 88MHz~216MHz  | 43.50              | Quasi-peak |
| 216MHz~960MHz | 46.00              | Quasi-peak |
| 960MHz~1GHz   | 54.00              | Quasi-peak |
| Above 1GHz    | 54.00              | Average    |
|               | 74.00              | Peak       |

**TEST CONFIGURATION**

- 9 kHz ~ 30 MHz

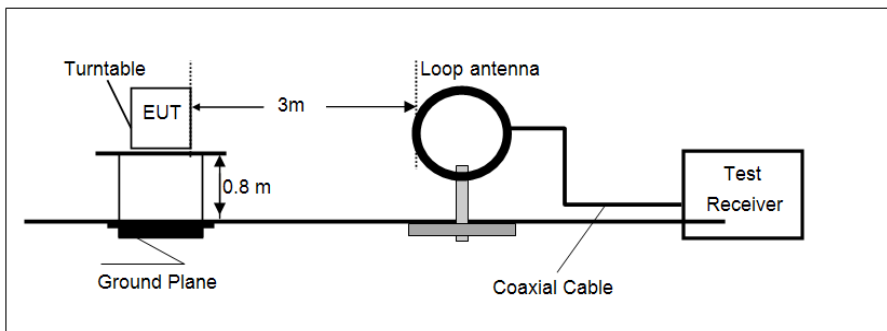

- 30 MHz ~ 1 GHz

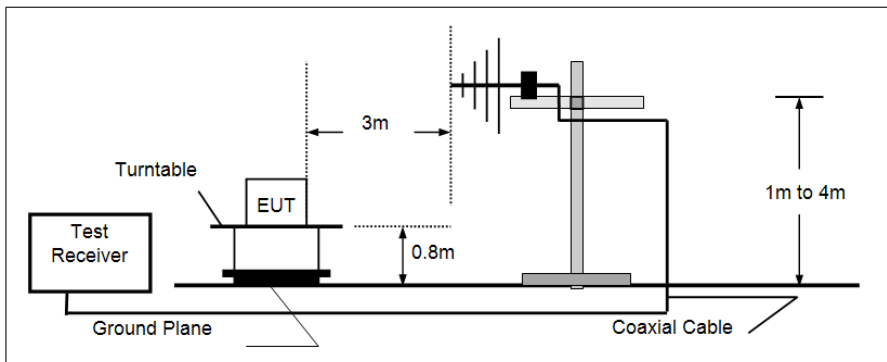

- Above 1 GHz

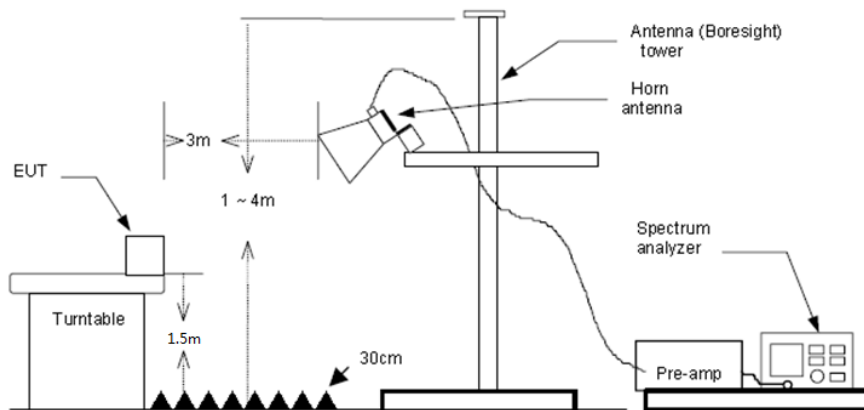

**TEST PROCEDURE**

1. The EUT was setup and tested according to ANSI C63.10:2013 requirements.
2. The EUT is placed on a turn table which is 0.8 meter above ground for below 1 GHz, and 1.5 m for above 1 GHz. The turn table is rotated 360 degrees to determine the position of the maximum emission level.
3. The EUT was set 3 meters from the receiving antenna, which was mounted on the top of a variable height antenna tower.
4. For each suspected emission, the EUT was arranged to its worst case and then tune the Antenna tower (from 1 m to 4 m) and turntable (from 0 degree to 360 degrees) to find the maximum reading. A pre-amp and a high pass filter are used for the test in order to get better signal level to comply with the guidelines.
5. Set to the maximum power setting and enable the EUT transmit continuously.
6. Use the following spectrum analyzer settings
  - (1) Span shall wide enough to fully capture the emission being measured;
  - (2) Below 1 GHz:  
RBW=120 kHz, VBW=300 kHz, Sweep=auto, Detector function=peak, Trace=max hold;  
If the emission level of the EUT measured by the peak detector is 3 dB lower than the applicable limit, the peak emission level will be reported. Otherwise, the emission measurement will be repeated using the quasi-peak detector and reported.
  - (3) From 1 GHz to 10<sup>th</sup> harmonic:  
RBW=1MHz, VBW=3MHz Peak detector for Peak value.  
RBW=1MHz, VBW=3MHz RMS detector for Average value.

**TEST MODE:**

Please refer to the clause 3.3

**TEST RESULTS**

**Passed**       **Not Applicable**



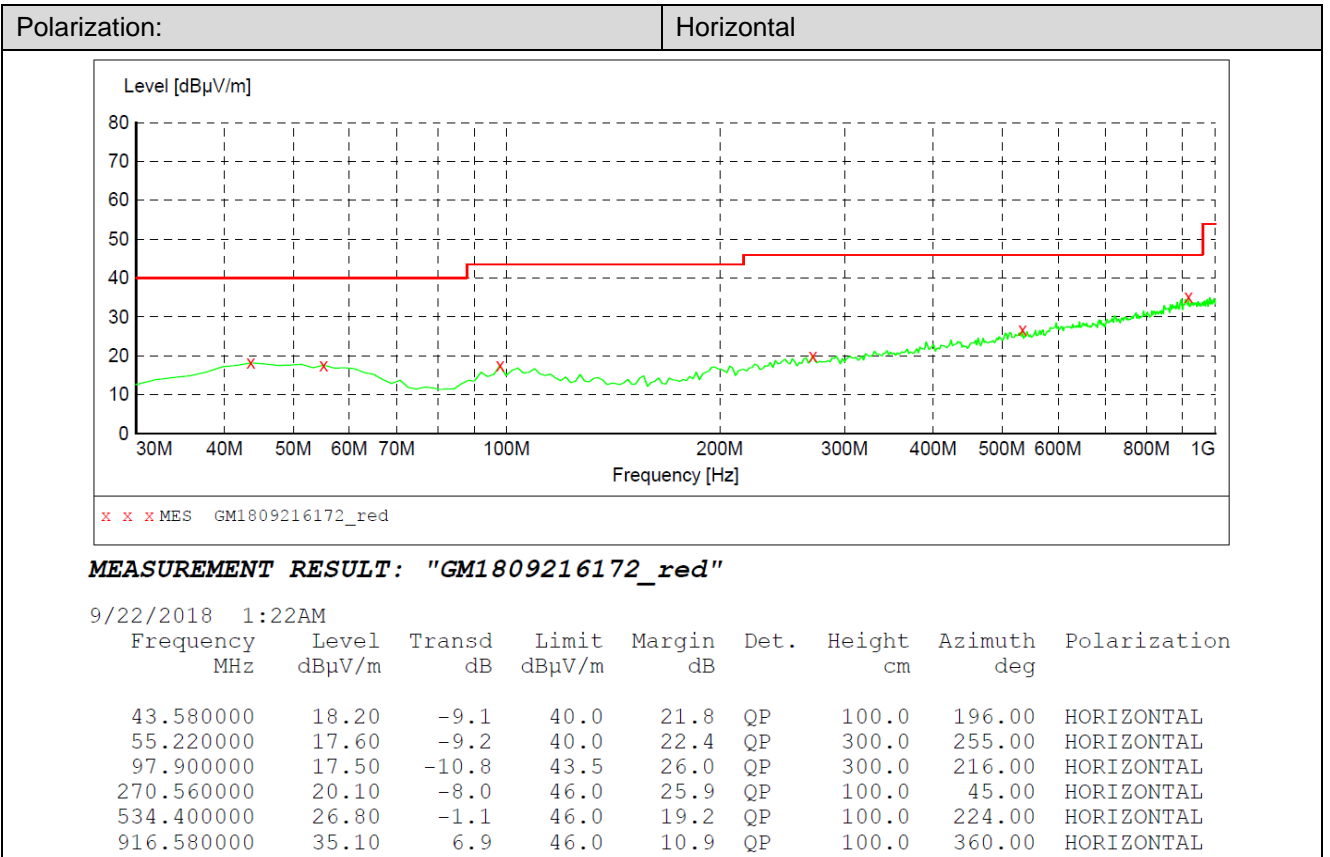
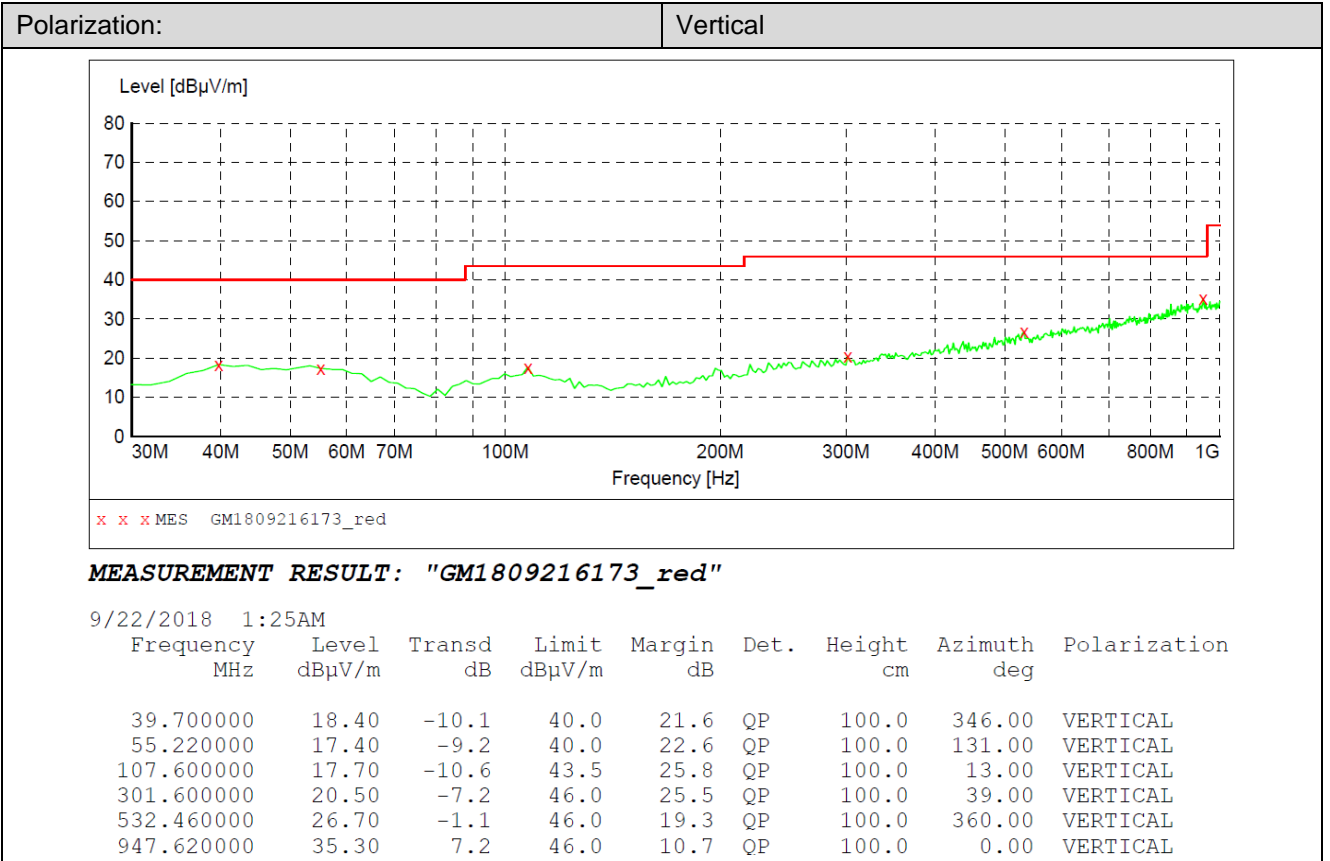

### 5.5. 20 dB Occupied Bandwidth

**Limit**

Intentional radiators must be designed to ensure that the 20dB emission bandwidth in the specific band 13.553~13.567MHz.

**TEST CONFIGURATION**

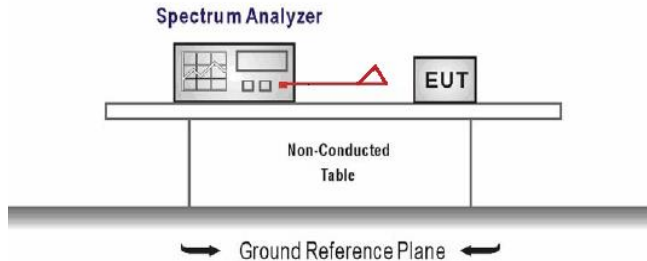

**TEST PROCEDURE**

1. The transmitter output was connected to the spectrum analyzer through an attenuator, the path loss was compensated to the results for each measurement.
2. Set to the maximum power setting and enable the EUT transmit continuously
3. Use the following spectrum analyzer settings:  
 Span = approximately 2 to 3 times the 20 dB bandwidth, centered on a hopping channel  
 RBW ≥ 1% of the 20 dB bandwidth, VBW ≥ RBW  
 Sweep = auto, Detector function = peak, Trace = max hold
4. Measure and record the results in the test report.

**TEST MODE:**

Please refer to the clause 3.3

**TEST RESULTS**

Passed       Not Applicable

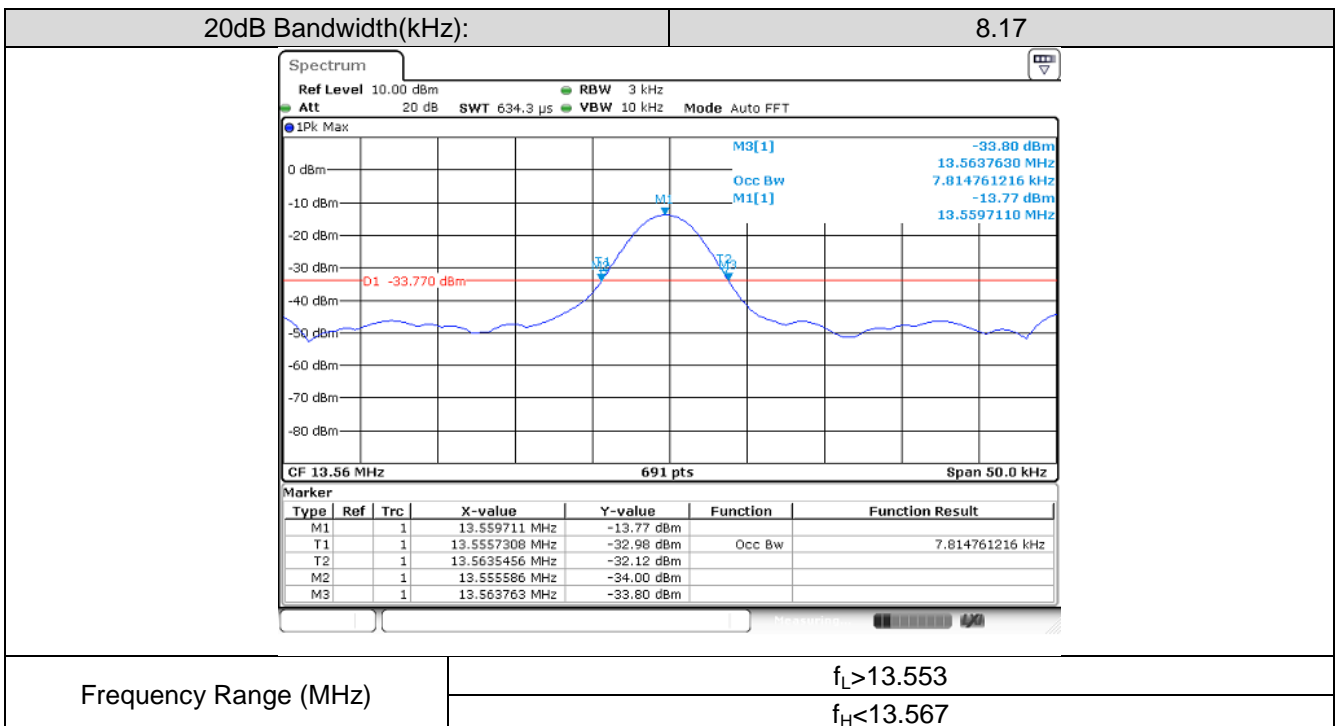

**5.6. Radiated field strength of the fundamental signal**

**LIMIT**

| Fundamental frequency(MHz)  | Field strength of fundamental (uV/m @30m) | Field strength of fundamental (dBuV/m @3m) |
|-----------------------------|---|--|
| 13.553-13.567               | 15.848                                    | 124.0                                      |
| 13.410-13.553&13.567-13.710 | 334                                       | 90.5                                       |
| 13.110-13.410&13.710-14.010 | 106                                       | 80.5                                       |

**TEST CONFIGURATION**

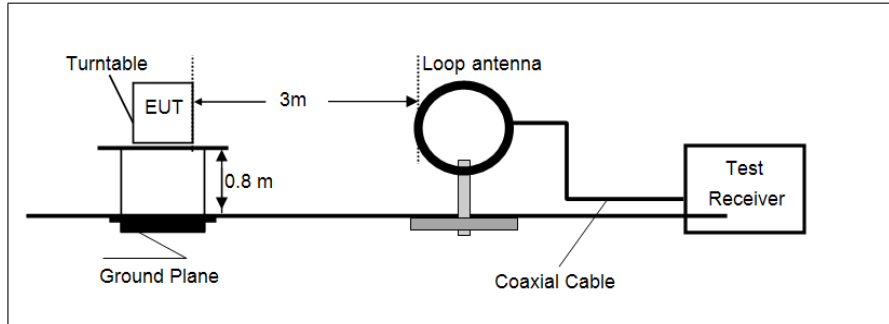

**TEST PROCEDURE**

1. The EUT was setup and tested according to ANSI C63.10:2013 requirements.
2. The EUT is placed on a turn table which is 0.8 meter above ground. The turn table is rotated 360 degrees to determine the position of the maximum emission level.
3. The EUT was positioned such that the distance from antenna to the EUT was 3 meters.
4. The antenna is scanned from 1 meter to 4 meters to find out the maximum emission level. This is repeated for both horizontal and vertical polarization of the antenna. In order to find the maximum emission, all of the interface cables were manipulated according to ANSI C63.10:2013 on radiated measurement.
5. The receiver set as follow:

| Frequency   | Detector   | RBW    | VBW    | Remark           |
|-------------|------------|--------|--------|------------------|
| 9kHz-150kHz | Quasi-peak | 200Hz  | 600Hz  | Quasi-peak Value |
| 50kHz-30MHz | Quasi-peak | 9kHz   | 30kHz  | Quasi-peak Value |
| 30MHz-1GHz  | Quasi-peak | 120kHz | 300KHz | Quasi-peak Value |
| Above 1GHz  | Peak       | 1MHz   | 3MHz   | Peak Value       |

**TEST MODE:**

Please refer to the clause 3.3

**TEST RESULTS**

Passed       Not Applicable

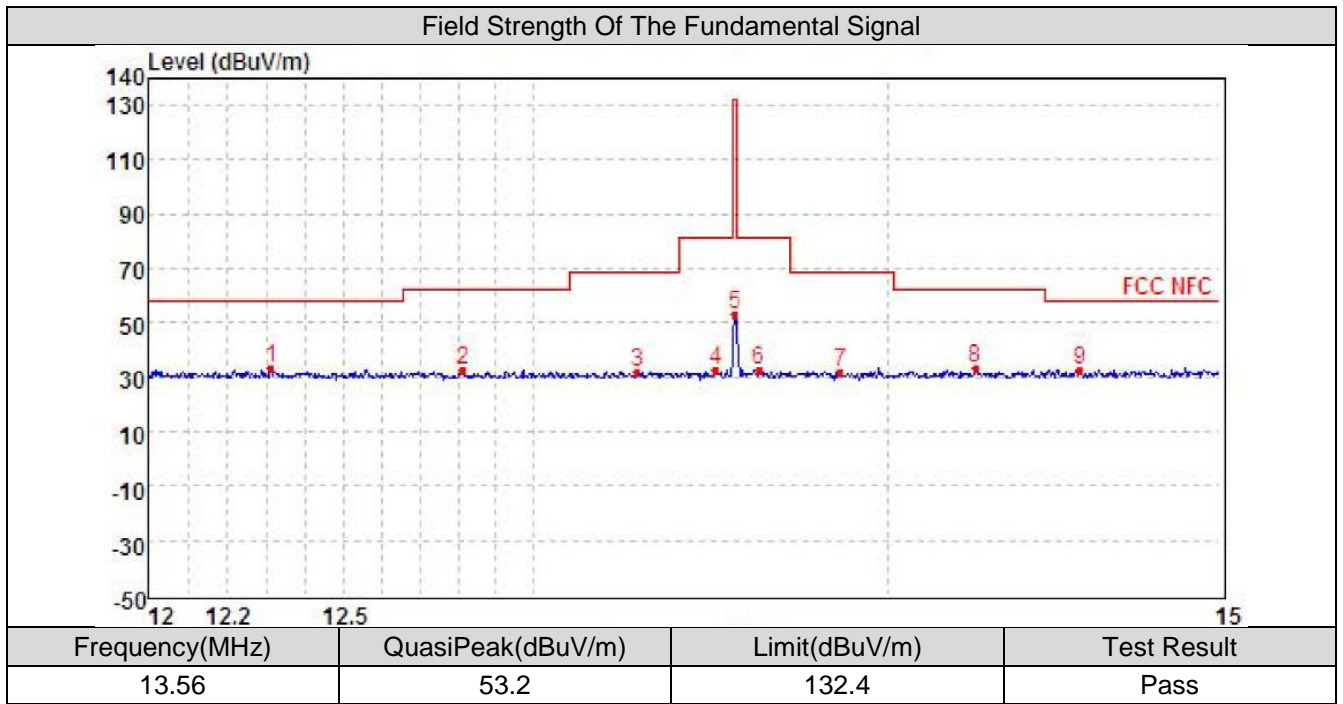

### 5.7. Out of Band Emission

#### LIMIT

| Frequency(MHz) | Field strength (dBuV/m) |
|----------------|-------------------------|
| 0.009-0.490    | 2400/F(kHz) at 300m     |
| 0.490-1.705    | 24000/F(kHz) at 30m     |
| 1.705-30       | 29.54 at 30m            |

Note:For measurements in the band 0.009MHz to 0.490MHz the specified measurement distance is 300m. The distance correction will be: Correction =  $40 \cdot \log(300/3) = 80\text{dB}$

For measurements in the band 0.490MHz to 30MHz the specified measurement distance is 30m. The distance correction will be: Correction =  $20 \cdot \log(30/3) = 20\text{dB}$

#### TEST CONFIGURATION

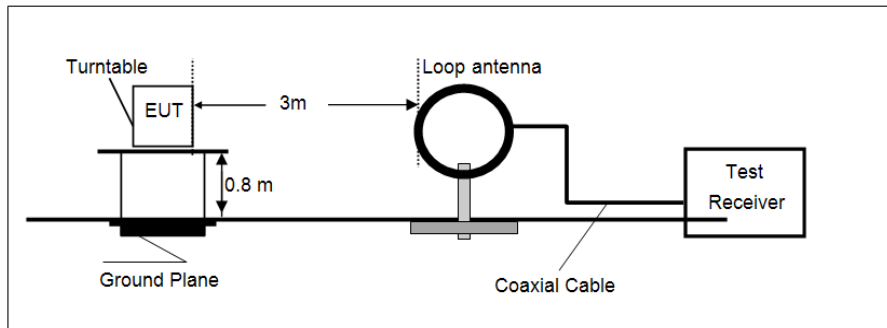

#### TEST PROCEDURE

1. The EUT was setup and tested according to ANSI C63.10:2013 requirements.
2. The EUT is placed on a turn table which is 0.8 meter above ground. The turn table is rotated 360 degrees to determine the position of the maximum emission level.
3. The EUT was positioned such that the distance from antenna to the EUT was 3 meters.
4. The antenna is scanned from 1 meter to 4 meters to find out the maximum emission level. This is repeated for both horizontal and vertical polarization of the antenna. In order to find the maximum emission, all of the interface cables were manipulated according to ANSI C63.10:2013 on radiated measurement.
5. The receiver set as follow:

| Frequency   | Detector   | RBW    | VBW    | Remark           |
|-------------|------------|--------|--------|------------------|
| 9kHz-150kHz | Quasi-peak | 200Hz  | 600Hz  | Quasi-peak Value |
| 50kHz-30MHz | Quasi-peak | 9kHz   | 30kHz  | Quasi-peak Value |
| 30MHz-1GHz  | Quasi-peak | 120kHz | 300KHz | Quasi-peak Value |
| Above 1GHz  | Peak       | 1MHz   | 3MHz   | Peak Value       |

#### TEST MODE:

Please refer to the clause 3.3

#### TEST RESULTS

Passed       Not Applicable

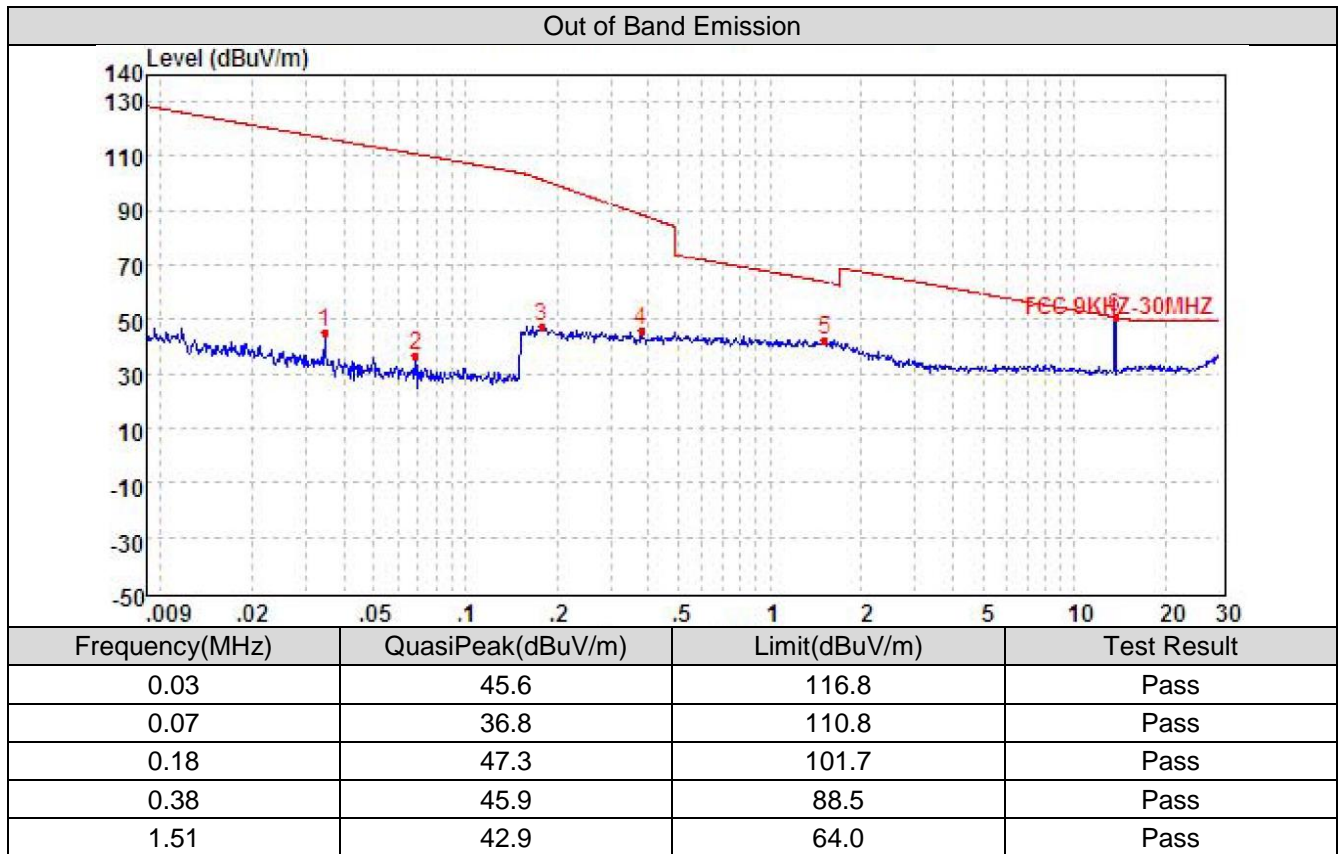

## 5.8. Frequency Stability

### LIMIT

The frequency tolerance of the carrier signal shall be maintained within  $\pm 0.01\%$  of the operating frequency over a temperature variation of  $-20$  degrees to  $+ 50$  degrees C at normal supply voltage, and for a variation in the primary supply voltage from 85% to 115% of the rated supply voltage at a temperature of 20 degrees C. For battery operated equipment, the equipment tests shall be performed using a new battery.

### TEST CONFIGURATION

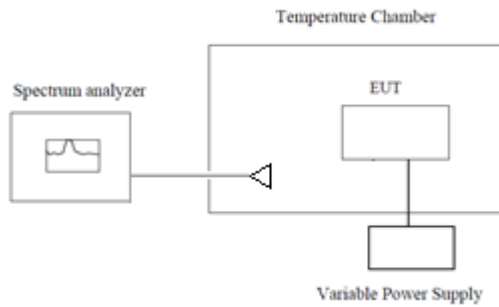

### TEST PROCEDURE

1. The equipment under test was connected to an external power supply.
2. RF output was connected to a frequency counter or spectrum analyzer via feed through attenuators.
3. The EUT was placed inside the temperature chamber.
4. Set the spectrum analyzer RBW low enough to obtain the desired frequency resolution and measure EUT 25°C operating frequency as reference frequency.
5. Turn EUT off and set the chamber temperature to  $-20^{\circ}\text{C}$ . After the temperature stabilized for approximately 30 minutes recorded the frequency.
6. Repeat step measure with  $10^{\circ}\text{C}$  increased per stage until the highest temperature of  $+50^{\circ}\text{C}$  reached.

### TEST MODE:

Please refer to the clause 3.3

### TEST RESULTS

Passed       Not Applicable

| Test Enviroment |                                   | Frequency Reading(MHz) | Frequency Error(%) | Limit        | Result |
|-----------------|-----------------------------------|------------------------|--------------------|--------------|--------|
| Voltage         | Temperature( $^{\circ}\text{C}$ ) |                        |                    |              |        |
| DC3.85V         | -20                               | 13.56005               | 0.005%             | $\pm 0.01\%$ | Pass   |
|                 | -10                               | 13.56004               | 0.004%             | $\pm 0.01\%$ | Pass   |
|                 | 0                                 | 13.56004               | 0.004%             | $\pm 0.01\%$ | Pass   |
|                 | 10                                | 13.56006               | 0.006%             | $\pm 0.01\%$ | Pass   |
|                 | 20                                | 13.56005               | 0.005%             | $\pm 0.01\%$ | Pass   |
|                 | 30                                | 13.56006               | 0.006%             | $\pm 0.01\%$ | Pass   |
|                 | 40                                | 13.56009               | 0.009%             | $\pm 0.01\%$ | Pass   |
|                 | 50                                | 13.56012               | 0.012%             | $\pm 0.01\%$ | Pass   |
| DC3.3V          | 20                                | 13.56004               | 0.004%             | $\pm 0.01\%$ | Pass   |
| DC4.4V          | 20                                | 13.56006               | 0.006%             | $\pm 0.01\%$ | Pass   |



## 6. TEST SETUP PHOTOS OF THE EUT

Radiated Emissions

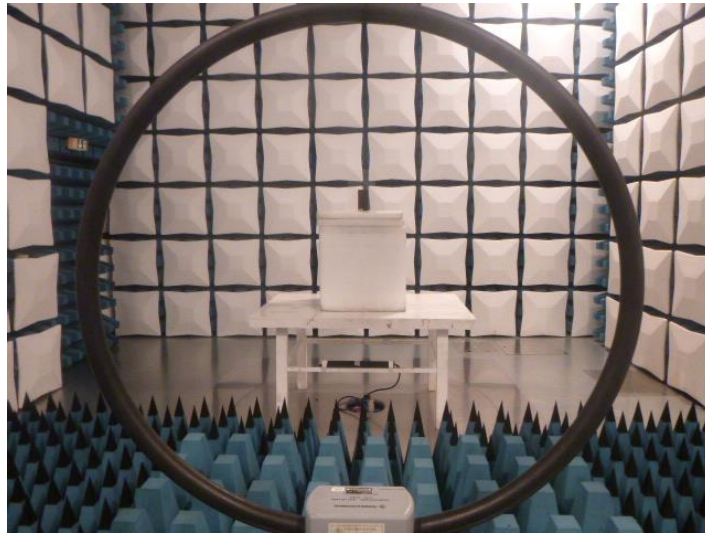

## 7. EXTERNAL AND INTERNAL PHOTOS OF THE EUT

Reference to the test report No.: TRE1809007001

-----End of Report-----