



FCC SAR TEST REPORT

Report No.: SET2021-12886

Product: Mason Smartphone

Trade Name:  

Model No.: D215 Pro

FCC ID: 2AJZP-D215PRO

Applicant: Mason American Inc.

Address: 2101 4TH AVE STE 1550 SEATTLE, WA 98121-2316

Issued by: CCIC Southern Testing Co., Ltd.

Lab Location: Electronic Testing Building, No. 43 Shahe Road Xili Street, Nanshan District, Shenzhen, Guangdong 518055, China

Tel: 86 755 26627338 **Fax:** 86 755 26627238

Mail: manager@ccic-set.com **Website:** <http://www.ccic-set.com>

This test report consists of 71 pages in total. It may be duplicated completely for legal use with the approval of the applicant. It should not be reproduced except in full, without the written approval of our laboratory. The client should not use it to claim product endorsement by CCIC-SET. The test results in the report only apply to the tested sample. The test report shall be invalid without all the signatures of testing engineers, reviewer and approver. Any objections must be raised to CCIC-SET within 15 days since the date when the report is received. It will not be taken into consideration beyond this limit.



Test Report

Product: Mason Smartphone
Model No.: D215 Pro
Brand Name.....: MASON
FCC ID.....: 2AJZP-D215PRO
Applicant.....: Mason American Inc.
Applicant Address.....: 2101 4TH AVE STE 1550 SEATTLE, WA 98121-2316
Manufacturer.....: Mason American Inc.
Manufacturer Address: 2101 4TH AVE STE 1550 SEATTLE, WA 98121-2316

Test Standards.....: **47CFR §2.1093-** Radiofrequency Radiation Exposure Evaluation: Portable Devices;
ANSI C95.1–1992: Safety Levels with Respect to Human Exposure to Radio Frequency Electromagnetic Fields, 3 kHz – 300 GHz.(IEEE Std C95.1-1991)
IEEE 1528–2013: IEEE Recommended Practice for Determining the Peak Spatial-Average Specific Absorption Rate (SAR) in the Human Head from Wireless Communications Devices: Measurement Techniques

Test Result.....: Pass
Test Date.....: 2021.09.09-2021.11.09

Tested by: Xinyuan Fang 2021-11-10
Xinyuan Fang, Test Engineer

Reviewed by.....: Chris You 2021-11-10
Chris You, Senior Engineer

Approved by.....: Shuangwen Zhang 2021-11-10
Shuangwen Zhang, Manager



Contents

Test Report	2
1. Administrative Data.....	4
2. Equipment Under Test (EUT)	5
3. SAR Summary	7
4. Specific Absorption Rate (SAR).....	9
5. Tissue check and recommend Dielectric Parameters	13
6. SAR measurement procedure	19
7. Conducted RF Output Power	20
8. Scaling Factor calculation	47
9. Test Results	50
10. Simultaneous Transmissions Analysis	67
11. Measurement Uncertainty.....	70
12. Equipment List.....	74
ANNEX A: Appendix A: SAR System performance Check Plots.....	75
ANNEX B: Appendix B: SAR Measurement results Plots.....	75
ANNEX C: Appendix C: Calibration reports	75
ANNEX D: Appendix D: SAR Test Setup.....	75



1. Administrative Data

1.1 Testing Laboratory

Test Site: CCIC Southern Testing Co., Ltd.

Address: Electronic Testing Building, No. 43 Shahe Road Xili Street, Nanshan District, Shenzhen, Guangdong 518055, China

A2LA Lab Code: CCIC-SET is a third party testing organization accredited by A2LA according to ISO/IEC 17025:2017. The accreditation certificate number is 5721.01

FCC Registration: CCIC Southern Testing Co., Ltd. EMC Laboratory has been registered and fully described in a report filed with the FCC (Federal Communications Commission). The acceptance letter from the FCC is maintained in our files. Designation Number: CN1283, valid time is until April 19th, 2023.

ISED Registration: CCIC Southern Testing Co., Ltd. EMC Laboratory has been registered by Certification and Engineering Bureau of Industry Canada for the performance of radiated measurements with Registration No. 11185A-1 on Aug. 04, 2016, valid time is until June 30th, 2023.

Test Environment Temperature (°C): 22 °C

Condition: Relative Humidity (%): 57%

Atmospheric Pressure (kPa): 86KPa-106KPa

2. Equipment Under Test (EUT)

Identification of the Equipment under Test

Device Type:	Portable
Exposure Category:	Population/Uncontrolled
Sample Name:	Mason Smartphone
Brand Name:	MASON
Model Name:	D215 Pro
Test Band	GSM850MHz /1900MHz, WCDMA 850MHz/1700MHz/1900MHz, LTE Band 2/4/5/7/12/17/41/66/71,WIFI 2.4G&5G, BT
Device Class	Class B
Multi Class	GPRS: Class 12; EGPRS: Class 12
Development Stage	Identical Prototype
Accessories	Power Supply
General description:	
Hotspot	2.4GHz WLAN support Hotspot mode
Antenna type	Internal Antenna
Operation mode	GSM /WCDMA / LTE /WIFI
Modulation mode	GSM(GMSK),UMTS(QPSK),LTE(QPSK,16QAM,64QAM), WIFI(DSSS/OFDM),BT(GFSK/ π /4-DQPSK/8-DPSK)
DTM mode	Not support
Hardware Version	HS21-MB-P1
Software Version	D215_Pro_MS_V02_20210812
Battery options :	Model No.:LS058 Capacitance:2900mAh Rated Voltage: 3.85V Charge Limit: 4.40V Manufacturer:Shenzhen Aerospace ElectronicCo.,Ltd
Max. SAR Value	Head: 0.175W/Kg Body: 0.993 W/Kg(Limit:1.6W/Kg, 10mm distance)

NOTE:

- The above EUT's information was declared by manufacturer. Please refer to the specifications or user's manual for more detailed description.



EUT testing configuration

Tested frequency range(s)	Transmitter Frequency Range	Receiver Frequency Range
GSM850:	824-849 MHz	869-894 MHz
GSM1900:	1850-1910 MHz	1930-1990 MHz
UMTS Band II:	1850-1910 MHz	1930-1990 MHz
UMTS Band IV:	1710-1755 MHz	2110-2155 MHz
UMTS Band V:	824-849 MHz	869-894 MHz
LTE Band2:	1850-1910 MHz	1930-1990 MHz
LTE Band4:	1710-1755 MHz	2110-2155 MHz
LTE Band5:	824-849 MHz	869-894 MHz
LTE Band7:	2500-2570 MHz	2620-2690 MHz
LTE Band12:	698-716 MHz	728-746 MHz
LTE Band17:	704-716 MHz	734-746 MHz
LTE Band41:	2496-2690 MHz	
LTE Band66:	1710-1780 MHz	2110-2200 MHz
LTE Band 71	663-698MHz	617-652MHz
WIFI(tested):	2412-2462 MHz	
	5150-5250 MHz	
	5250-5350 MHz	
	5470-5725 MHz	
	5745-5825 MHz	
Bluetooth:	2402-2480 MHz	
Test channels(low-mid-high):	128-190-251(GSM850)	
	512-661-810(GSM1900)	
	9262-9400-9538(UMTS Band II)	
	1312-1412-1513(UMTS Band IV)	
	4132-4183-4233(UMTS Band V)	
	18700-18900-19100(LTE Band 2 Bandwidth 20M)	
	20050-20175-20300(LTE Band 4 Bandwidth 20M)	
	20450-20525-20600(LTE Band 5 Bandwidth 10M)	
	20850-21100-21350(LTE Band 7 Bandwidth 10M)	
	23060-23095-23130(LTE Band 12 Bandwidth 10M)	
	23780-23790-23800(LTE Band 17 Bandwidth 10M)	
	23780-23790-23800(LTE Band 41Bandwidth 20M)	
	27310-27460-27560(LTE Band 66Bandwidth 20M)	
	133222-133322-133372(LTE Band 71Bandwidth 20M)	
	1-6-11(Wi-Fi 2.4G 802.11b)	
5190-5270-5590-5795 (WIFI 5G)		
0-39-78(BT)		



3. SAR Summary

Highest Standalone SAR Summary

Exposure Position	Frequency Band	Scaled 1g-SAR(W/kg)	Highest Scaled 1g-SAR(W/kg)
Head	GSM850	0.106	0.175
	GSM1900	0.084	
	WCDMA Band II	0.053	
	WCDMA Band IV	0.030	
	WCDMA Band V	0.046	
	LTE Band 2	0.064	
	LTE Band 4	0.046	
	LTE Band 5	0.039	
	LTE Band 7	0.013	
	LTE Band 12	0.048	
	LTE Band 17	0.039	
	LTE Band 41	0.019	
	LTE Band 66	0.062	
	LTE Band 71	0.175	
	WIFI 2.4G 802.11b	0.104	
	WIFI 5G 802.11a	0.105	
BT	0.050		

Exposure Position	Frequency Band	Scaled 1g-SAR(W/kg)	Highest Scaled 1g-SAR(W/kg)
Body-worn (10mm Gap)	GSM850	0.336	0.682
	GSM1900	0.583	
	WCDMA Band II	0.119	
	WCDMA Band IV	0.186	
	WCDMA Band V	0.035	
	LTE Band 2	0.120	
	LTE Band 4	0.259	
	LTE Band 5	0.033	
	LTE Band 7	0.235	
	LTE Band 12	0.051	
	LTE Band 17	0.043	
	LTE Band 41	0.067	
	LTE Band 66	0.682	
	LTE Band 71	0.188	
	WIFI 2.4G 802.11b	0.100	
	WIFI 5G 802.11a	0.095	
BT	0.019		



Exposure Position	Frequency Band	Scaled 1g-SAR(W/kg)	Highest Scaled 1g-SAR(W/kg)
Hotspot (10mm Gap)	GSM850	0.336	0.993
	GSM1900	0.993	
	WCDMA Band II	0.187	
	WCDMA Band IV	0.298	
	WCDMA Band V	0.045	
	LTE Band 2	0.203	
	LTE Band 4	0.382	
	LTE Band 5	0.033	
	LTE Band 7	0.236	
	LTE Band 12	0.051	
	LTE Band 17	0.043	
	LTE Band 41	0.076	
	LTE Band 66	0.682	
	LTE Band 71	0.188	
	WIFI 2.4G 802.11b	0.100	

Highest Simultaneous SAR Summary

Exposure Position	Frequency Band	Highest Scaled 1g-SAR(W/kg)
Hotspot (10mmGap)	WWAN(LTE Band 66)&WIFI 2.4G	0.782

4. Specific Absorption Rate (SAR)

4.1 Introduction

SAR is related to the rate at which energy is absorbed per unit mass in an object exposed to a radio field. The SAR distribution in a biological body is complicated and is usually carried out by experimental techniques or numerical modeling. The standard recommends limits for two tiers of groups, occupational/controlled and general population/uncontrolled, based on a person's awareness and ability to exercise control over his or her exposure. In general, occupational/controlled exposure limits are higher than the limits for general population/uncontrolled.

The SAR definition is the time derivative (rate) of the incremental energy (dW) absorbed by (dissipated in) an incremental mass (dm) contained in a volume element (dv) of a given density (ρ). The equation description is as below:

$$\text{SAR} = \frac{d}{dt} \left(\frac{dW}{dm} \right) = \frac{d}{dt} \left(\frac{dW}{\rho dv} \right)$$

SAR is expressed in units of Watts per kilogram (W/kg)

SAR measurement can be either related to the temperature elevation in tissue by

$$\text{SAR} = C \frac{\delta T}{\delta t}$$

where C is the specific heat capacity, δT is the temperature rise and δt the exposure duration, or related to the electrical field in the tissue by

$$\text{SAR} = \frac{\sigma |E|^2}{\rho}$$

where σ is the conductivity of the tissue, ρ is the mass density of the tissue and E is the rms electrical field strength.

However for evaluating SAR of low power transmitter, electrical field measurement is typically applied.



4.2 Applicable Standards and Limits

4.2.1 Applicable Standards

47CFR §2.1093	Radiofrequency Radiation Exposure Evaluation: Portable Devices
ANSI C95.1-1992	Safety Levels with Respect to Human Exposure to Radio Frequency Electromagnetic Fields, 3 kHz – 300 GHz.(IEEE Std C95.1-1991)
IEEE 1528-2013	IEEE Recommended Practice for Determining the Peak Spatial-Average Specific Absorption Rate (SAR) in the Human Head from Wireless Communications Devices: Measurement Techniques
KDB 248227 D01	v02r02 802.11 Wi-Fi SAR
KDB 447498 D01	v06 General RF Exposure Guidance
KDB 648474 D04	v01r03 Handset SAR
KDB 865664 D01	v01r04 SAR Measurement 100MHz to 6GHz
KDB 865664 D02	v01r02 SAR Exposure Reporting
KDB 941225 D01	v03r01 3G SAR Procedures
KDB 941225 D05	v02r05 SAR for LTE Devices
KDB 941225 D05A	v01r02 LTE Rel.10 KDB Inquiry Sheet
KDB 941225 D06	v02r01 Hotspot Mode

4.2.2 RF exposure Limits

Human Exposure	Uncontrolled Environment General Population
Spatial Peak SAR* (Brain/Body)	1.60 mW/g
Spatial Average SAR** (Whole Body)	0.08 mW/g
Spatial Peak SAR*** (Limbs)	4.00 mW/g

The limit applied in this test report is shown in bold letters.

Notes:

* The Spatial Peak value of the SAR averaged over any 10 grams of tissue (defined as a tissue volume in the shape of a cube) and over the appropriate averaging time

** The Spatial Average value of the SAR averaged over the whole body.

*** The Spatial Peak value of the SAR averaged over any 10 grams of tissue (defined as a tissue volume in the shape of a cube) and over the appropriate averaging time.

4.3 Phantoms

The phantom used for all tests i.e. for both system checks and device testing, was the twin-headed "SAM Phantom", manufactured by SATIMO. The SAM twin phantom is a fiberglass shell phantom with 2mm shell thickness (except the ear region, where shell thickness increases to 6mm).

System checking was performed using the flat section, whilst Head SAR tests used the left and right head profile sections. Body SAR testing also used the flat section between the head profiles.



SAM Twin Phantom

4.4 Device Holder

The device was placed in the device holder (illustrated below) that is supplied by SATIMO as an integral part of the COMOSAR test system.

The device holder is designed to cope with the different positions given in the standard. It has two scales for device rotation (with respect to the body axis) and device inclination (with respect to the line between the ear reference points). The rotation centers for both scales is the ear reference point (ERP). Thus the device needs no repositioning when changing the angles.

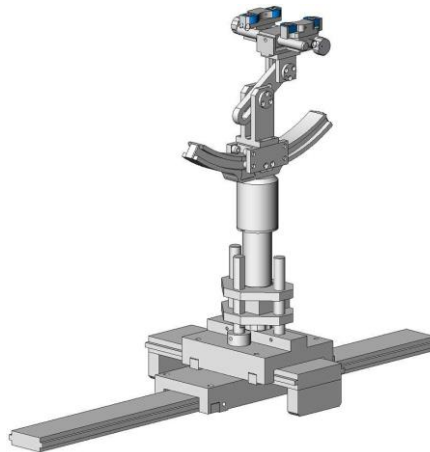

Device holder

4.5 Probe Specification



Construction	Symmetrical design with triangular core Interleaved sensors Built-in shielding against static charges PEEK enclosure material (resistant to organic solvents, e.g., DGBE)
Calibration	ISO/IEC 17025 calibration service available.
Frequency	700 MHz to 3 GHz; Linearity: ± 0.5 dB (700 MHz to 3 GHz)
Directivity	± 0.25 dB in HSL (rotation around probe axis) ± 0.5 dB in tissue material (rotation normal to probe axis)
Dynamic Range	1.5 μ W/g to 100 mW/g; Linearity: ± 0.5 dB
Dimensions	Overall length: 330 mm (Tip: 20 mm) Tip diameter: 5 mm Distance from probe tip to dipole centers: <2.7 mm
Application	General dosimetry up to 3 GHz Dosimetry in strong gradient fields Compliance tests of mobile phones
Compatibility	COMOSAR

Isotropic E-Field Probe

The isotropic E-Field probe has been fully calibrated and assessed for isotropicity, and boundary effect within a controlled environment. Depending on the frequency for which the probe is calibrated the method utilized for calibration will change.

The E-Field probe utilizes a triangular sensor arrangement as detailed in the diagram below:

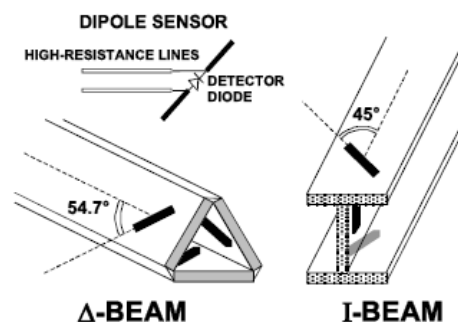

5. Tissue check and recommend Dielectric Parameters

5.1 Tissue Dielectric Parameters for Head and Body Phantoms

The head tissue dielectric parameters recommended by the IEEE SCC-34/SC-2 in P1528 have been incorporated in the following table. These head parameters are derived from planar layer model simulating the highest expected SAR for the dielectric properties and tissue thickness Power drifts in a human head. Other head and body tissue parameters that have not been specified in P1528 are derived from the tissue dielectric parameters computed from the 4-Cole-Cole equations described in Reference [12] and extrapolated according to the head parameters specified in P1528.

Table 1: Recommended Dielectric Performance of Tissue

Ingredients (% by weight)	Frequency (MHz)											
	450		835		915		1900		2450		2600	
Tissue Type	Head	Body	Head	Body	Head	Body	Head	Body	Head	Body	Head	Body
Water	38.56	51.16	41.46	52.4	41.05	56.0	54.9	40.4	62.7	73.2	55.24	64.49
Salt (NaCl)	3.95	1.49	1.45	1.4	1.35	0.76	0.18	0.5	0.5	0.04	0.5	0.024
Sugar	56.32	46.78	56.0	45.0	56.5	41.76	0.0	58.0	0.0	0.0	0.0	0.0
HEC	0.98	0.52	1.0	1.0	1.0	1.21	0.0	1.0	0.0	0.0	0.0	0.0
Bactericide	0.19	0.05	0.1	0.1	0.1	0.27	0.0	0.1	0.0	0.0	0.0	0.0
Triton x-100	0.0	0.0	0.0	0.0	0.0	0.0	0.0	0.0	36.8	0.0	44.45	32.25
DGBE	0.0	0.0	0.0	0.0	0.0	0.0	44.92	0.0	0.0	26.7	0.0	26.7
Dielectric Constant	43.42	58.0	42.54	56.1	42.0	56.8	39.9	54.0	39.2	52.5	39.0	52.5
Conductivity (s/m)	0.85	0.83	0.91	0.95	1.0	1.07	1.42	1.45	1.80	1.78	1.96	2.16

MSL/HSL750 (Body and Head liquid for 650 – 850 MHz)

Item	Head Tissue Simulation Liquid HSL750 Muscle(body)Tissue Simulation Liquid MSL750			
H2O	Water, 35 – 58%			
Sucrose	Sugar, white, refined, 40-60%			
NaCl	Sodium Chloride, 0-6%			
Hydroxyethyl-cellulose	Medium Viscosity (CAS# 9004-62-0), <0.3%			
Preventol-D7	Preservative: aqueous preparation, (CAS# 55965-84-9), containing 5-chloro-2-methyl-3(2H)-isothiazolone and 2-methyl-3(2H)-isothiazolone, 0.1-0.7%			
Frequency (MHz)	Head ϵ_r	Head σ (S/m)	Body ϵ_r	Body σ (S/m)
750	41.9	0.89	55.2	0.97

Note: The liquid of 700MHz&2600MHz typical liquid composition is provided by SATIMO.

Frequency:5200/5400/5600/5800MHz	
Ingredients	(% by weight)
Water	78
Mineral oil	11
Emulsifiers	9
Additives and Salt	2

Table 2 Recommended Tissue Dielectric Parameters

Frequency (MHz)	Head Tissue		Body Tissue	
	ϵ_r	σ (S/m)	ϵ_r	σ (S/m)
150	52.3	0.76	61.9	0.80
300	45.3	0.87	58.2	0.92
450	43.5	0.87	56.7	0.94
835	41.5	0.90	55.2	0.97
900	41.5	0.97	55.0	1.05
915	41.5	0.98	55.0	1.06
1450	40.5	1.20	54.0	1.30
1610	40.3	1.29	53.8	1.40
1800-2000	40.0	1.40	53.3	1.52
2450	39.2	1.80	52.7	1.95
3000	38.5	2.40	52.0	2.73
5800	35.3	5.27	48.2	6.00

5.2 Simulate liquid

Liquid check results:

Table 3: Dielectric Performance of Head Tissue Simulating Liquid

Temperature: 22.8 °C; Humidity: 60%;			
/	Frequency	Permittivity ϵ	Conductivity σ (S/m)
Target value	750MHz	41.9 ±5%	0.89 ±5%
Validation value (2021-09-09)	750MHz	41.92	0.90
Target value	835MHz	41.5 ±5%	0.90 ±5%
Validation value (2021-09-10)	835MHz	41.50	0.90
Target value	1800MHz	40.5 ±5%	1.40 ±5%
Validation value (2021-09-13)	1800MHz	40.48	1.39
Target value	1900MHz	40.5 ±5%	1.40 ±5%
Validation value (2021-09-20)	1900MHz	40.55	1.43
Target value	2450MHz	39.2 ±5%	1.80 ±5%
Validation value (2021-09-15)	2450MHz	39.11	1.74
Target value	2600MHz	39.0 ±5%	1.96 ±5%
Validation value (2021-09-16)	2600MHz	38.93	1.94
Target value	5200MHz	36.0 ±5%	4.66 ±5%
Validation value (2021-09-17)	5200MHz	35.94	4.62
Target value	5400MHz	35.8 ±5%	4.86 ±5%
Validation value (2021-09-17)	5400MHz	35.91	4.95
Target value	5600MHz	35.5 ±5%	5.07 ±5%
Validation value (2021-09-18)	5600MHz	35.63	5.17
Target value	5800MHz	35.3 ±5%	5.27 ±5%
Validation value (2021-09-18)	5800MHz	35.20	5.19
Target value	750MHz	41.9 ±5%	0.89 ±5%
Validation value (2021-11-09)	750MHz	41.82	0.91

Dielectric Performance of Body Tissue Simulating Liquid

Temperature: 22.8 °C; Humidity: 60%;			
/	Frequency	Permittivity ϵ	Conductivity σ (S/m)
Target value	750MHz	55.5 \pm 5%	0.96 \pm 5%
Validation value (2021-09-09)	750MHz	55.53	0.97
Target value	835MHz	55.2 \pm 5%	0.97 \pm 5%
Validation value (2021-09-10)	835MHz	55.18	0.96
Target value	1800MHz	53.3 \pm 5%	1.52 \pm 5%
Validation value (2021-09-13)	1800MHz	53.27	1.51
Target value	1900MHz	53.3 \pm 5%	1.52 \pm 5%
Validation value (2021-09-20)	1900MHz	53.25	1.50
Target value	2450MHz	52.7 \pm 5%	1.95 \pm 5%
Validation value (2021-09-15)	2450MHz	52.75	1.98
Target value	2600MHz	52.5 \pm 5%	2.16 \pm 5%
Validation value (2021-09-16)	2600MHz	52.53	2.17
Target value	5200MHz	49.0 \pm 5%	5.30 \pm 5%
Validation value (2021-09-17)	5200MHz	49.10	5.36
Target value	5400MHz	48.7 \pm 5%	5.53 \pm 5%
Validation value (2021-09-17)	5400MHz	48.57	5.44
Target value	5600MHz	48.5 \pm 5%	5.77 \pm 5%
Validation value (2021-09-18)	5600MHz	48.58	5.82
Target value	5800MHz	48.2 \pm 5%	6.0 \pm 5%
Validation value (2021-09-18)	5800MHz	48.10	5.93
Target value	750MHz	55.5 \pm 5%	0.96 \pm 5%
Validation value (2021-11-09)	750MHz	55.62	0.94

SAR System validation

Prior to the assessment, the system validation kit was used to test whether the system was operating within its specifications of $\pm 10\%$. The validation results are tabulated below. And also the corresponding SAR plot is attached as well in the SAR plots files.

The following procedure, recommended for performing validation tests using box phantoms is based on the procedures described in the IEEE standard P1528. Setup according to the setup diagram below:

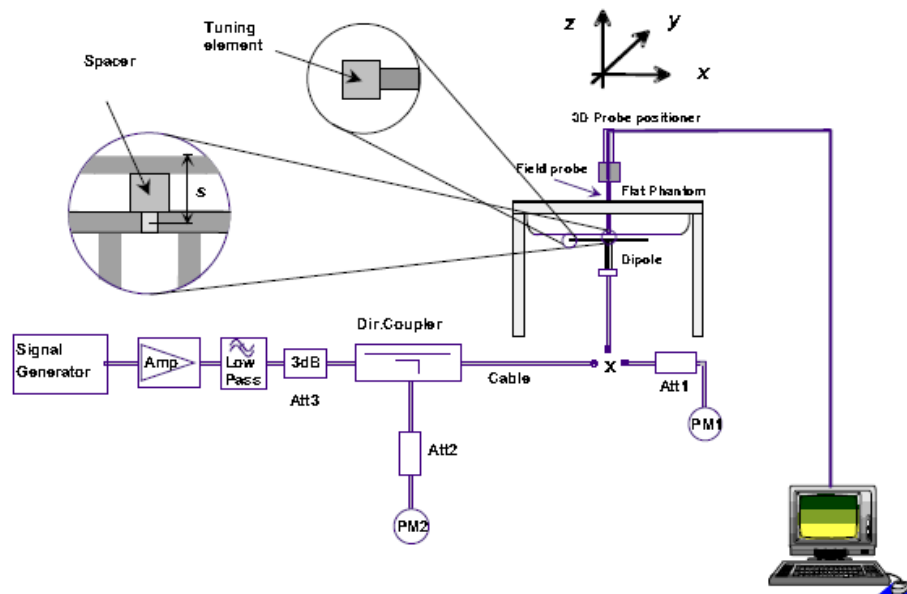

With the SG and Amp and with directional coupler in place, set up the source signal at the relevant frequency and use a power meter to measure the power at the end of the SMA cable that you intend to connect to the balanced dipole. Adjust the SG to make this, say, 0.01W (10 dBm). If this level is too high to read directly with the power meter sensor, insert a calibrated attenuator (e.g. 10 or 20 dB) and make a suitable correction to the power meter reading.

Note 1: In this method, the directional coupler is used for monitoring rather than setting the exact feed power level.

If, however, the directional coupler is used for power measurement, you should check the frequency range and power rating of the coupler and measure the coupling factor (referred to output) at the test frequency using a VNA.

Note 2: Remember that the use of a 3dB attenuator (as shown in Figure 8.1 of P1528) means that you need an RF amplifier of 2 times greater power for the same feed power. The other issue is the cable length. You might get up to 1dB of loss per meter of cable, so the cable length after the coupler needs to be quite short.

Note 3: For the validation testing done using CW signals, most power meters are suitable. However, if you are measuring the output of a modulated signal from either a signal generator or a handset, you must ensure that the power meter correctly reads the modulated signals.

The measured 1-gram averaged SAR values of the device against the phantom are provided in Tables 5 and Table 6. The humidity and ambient temperature of test facility were 64% and 23.2 °C respectively. The body phantom were full of the body tissue simulating liquid. The EUT was supplied with full-charged battery for each measurement.

The distance between the back of the EUT and the bottom of the flat phantom is 10 mm (taking into account of the IEEE 1528 and the place of the antenna).

Table 4: Head SAR system validation (1g)

Frequency	Duty cycle	Target value (W/kg)	Test value (W/kg)	
			10 mW	1W
750MHz(2021-09-09)	1:1	8.73 ±10%	0.0890	8.90
835MHz(2021-09-10)	1:1	9.69 ±10%	0.0969	9.69
1800MHz(2021-09-13)	1:1	37.25 ±10%	0.3702	37.02
1900MHz(2021-09-20)	1:1	39.71 ±10%	0.4024	40.24
2450MHz(2021-09-15)	1:1	53.71 ±10%	0.5306	53.06
2600MHz(2021-09-16)	1:1	56.47 ±10%	0.5596	55.96
5200MHz(2021-09-17)	1:1	151.11 ±10%	1.5076	150.76
5400MHz(2021-09-17)	1:1	159.92 ±10%	1.6117	161.17
5600MHz(2021-09-18)	1:1	165.99 ±10%	1.6898	168.98
5800MHz(2021-09-18)	1:1	176.86 ±10%	1.7477	174.77
750MHz(2021-11-09)	1:1	8.73 ±10%	0.0882	8.82

Body SAR system validation (1g)

Frequency	Duty cycle	Target value (W/kg)	Test value (W/kg)	
			10 mW	1W
750MHz(2021-09-09)	1:1	8.82 ±10%	0.0896	8.96
835MHz(2021-09-10)	1:1	9.97 ±10%	0.0983	9.83
1800MHz(2021-09-13)	1:1	38.57 ±10%	0.3840	38.40
1900MHz(2021-09-20)	1:1	40.69 ±10%	0.4036	40.36
2450MHz(2021-09-15)	1:1	54.83 ±10%	0.5532	55.32
2600MHz(2021-09-16)	1:1	57.16 ±10%	0.5745	57.45
5200MHz(2021-09-17)	1:1	150.13 ±10%	1.5172	151.72
5400MHz(2021-09-17)	1:1	152.16 ±10%	1.4987	149.87
5600MHz(2021-09-18)	1:1	154.92 ±10%	1.5583	155.83
5800MHz(2021-09-18)	1:1	158.10 ±10%	1.5674	156.74
750MHz(2021-11-09)	1:1	8.82 ±10%	0.0892	8.92

* Note: Target value was referring to the measured value in the calibration certificate of reference dipole.

Note: All SAR values are normalized to 1W forward power.

6. SAR measurement procedure

The SAR test against the head phantom was carried out as follow:

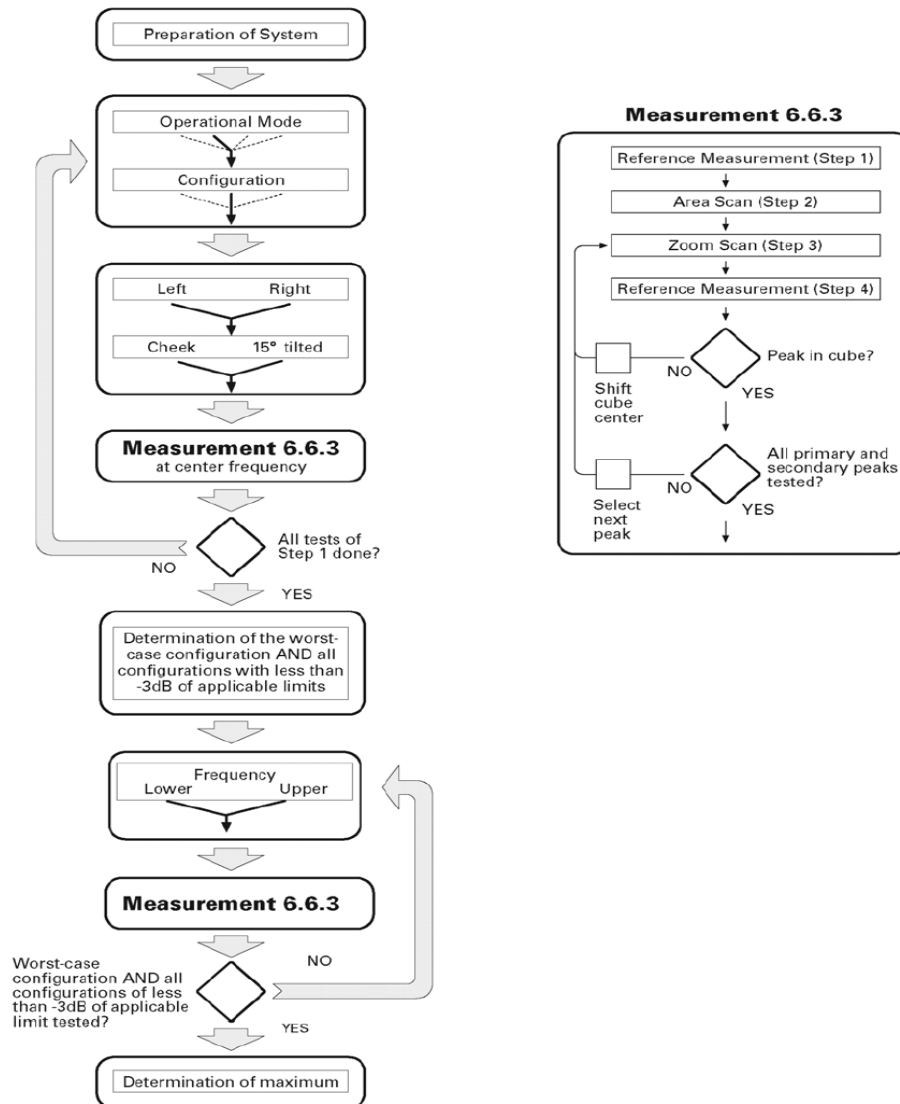

Establish a call with the maximum output power with a base station simulator, the connection between the EUT and the base station simulator is established via air interface.

After an area scan has been done at a fixed distance of 2mm from the surface of the phantom on the source side, a 3D scan is set up around the location of the maximum spot SAR. First, a point within the scan area is visited by the probe and a SAR reading taken at the start of testing. At the end of testing, the probe is returned to the same point and a second reading is taken. Comparison between these start and end readings enables the power drift during measurement to be assessed.

Above is the scanning procedure flow chart and table from the IEEE p1528 standard. This is the procedure for which all compliant testing should be carried out to ensure that all variations of the device position and transmission behavior are tested.



7. Conducted RF Output Power

7.1 GSM Conducted Power

GSM850		Burst-Averaged output Power (dBm)			Division Factors	Frame-Averaged output Power (dBm)		
		128CH	190CH	251CH		28CH	190CH	251CH
GSM (CS)		32.97	32.89	33.01	-9.03	23.94	23.86	23.98
GPRS (GMSK)	1 Tx Slot	32.87	32.78	32.76	-9.03	23.84	23.75	23.73
	2 Tx Slots	30.12	30.26	30.20	-6.02	24.10	24.24	24.18
	3 Tx Slots	28.54	28.66	28.60	-4.26	24.28	24.40	24.34
	4 Tx Slots	27.32	27.47	27.41	-3.01	24.31	24.46	24.40
EDGE (8PSK)	1 Tx Slot	27.58	27.54	27.57	-9.03	18.55	18.51	18.54
	2 Tx Slots	25.06	25.13	25.15	-6.02	19.04	19.11	19.13
	3 Tx Slots	23.51	23.63	23.56	-4.26	19.25	19.37	19.30
	4 Tx Slots	22.28	22.41	22.34	-3.01	19.27	19.40	19.33
GSM1900		Burst-Averaged output Power (dBm)			Division Factors	Frame-Averaged output Power (dBm)		
		512CH	661CH	810CH		512CH	661CH	810CH
GSM (CS)		30.12	30.36	30.47	-9.03	21.09	21.33	21.44
GPRS (GMSK)	1 Tx Slot	29.87	29.29	29.62	-9.03	20.84	20.26	20.59
	2 Tx Slots	27.34	27.42	27.38	-6.02	21.32	21.40	21.36
	3 Tx Slots	25.72	25.80	25.81	-4.26	21.46	21.54	21.55
	4 Tx Slots	24.51	24.72	24.63	-3.01	21.50	21.71	21.62
EDGE (8PSK)	1 Tx Slot	27.52	27.59	27.62	-9.03	18.49	18.56	18.59
	2 Tx Slots	25.08	25.14	25.20	-6.02	19.06	19.12	19.18
	3 Tx Slots	23.45	23.52	23.55	-4.26	19.19	19.26	19.29
	4 Tx Slots	22.23	22.38	22.40	-3.01	19.22	19.37	19.39

Note: Per KDB 447498 D01 v06, the maximum output power channel is used for SAR testing and for further SAR test reduction.

For hotspot SAR, EUT was performed at GPRS Class 12 multi-slots(4Tx) mode

For Head and Body-worn SAR testing, EUT was set in GSM Voice mode for both GSM850 and GSM1900

Timeslot consignations

No. Of Slots	Slot 1	Slot 2	Slot 3	Slot 4
Slot Consignation	1Up4Down	2UpDown	3UpDown	4Up1Down
Duty Cycle	1:8	1:4	1:2.67	1:2
Crest Factor	-9.03dB	-6.02dB	-4.26dB	-3.01dB

7.2 WCDMA Conducted output Power

UMTS1900 (Band II)		Average Power (dBm)		
		9262CH	9400CH	9538cH
WCDMA	12.2kbps RMC	24.35	24.25	24.3
HSDPA	Subtest 1	24.27	23.57	23.62
	Subtest 2	23.86	23.16	23.21
	Subtest 3	23.47	22.77	22.82
	Subtest 4	23.26	22.56	22.61
HSUPA	Subtest 1	24.17	24.07	23.85
	Subtest 2	23.72	23.62	23.4
	Subtest 3	23.33	23.23	23.01
	Subtest 4	23.05	22.95	22.73
	Subtest 5	22.86	22.76	22.54
UMTS1700 (Band IV)		Average Power (dBm)		
		1313CH	1413CH	1513CH
WCDMA	12.2kbps RMC	24.51	24.38	24.56
HSDPA	Subtest 1	23.83	23.7	23.88
	Subtest 2	23.42	23.29	23.47
	Subtest 3	23.03	22.9	23.08
	Subtest 4	22.82	22.69	22.87
HSUPA	Subtest 1	24.06	24.26	24.45
	Subtest 2	23.61	23.46	24.33
	Subtest 3	23.22	23.07	23.94
	Subtest 4	22.94	22.79	23.66
	Subtest 5	22.75	22.6	23.47
UMTS850 (Band V)		Average Power (dBm)		
		4132CH	4183CH	4233CH
WCDMA	12.2kbps RMC	23.98	23.89	23.94
HSDPA	Subtest 1	23.3	23.21	23.26
	Subtest 2	22.89	22.8	22.85
	Subtest 3	22.5	22.41	22.46
	Subtest 4	22.29	22.2	22.25
HSUPA	Subtest 1	23.87	23.81	22.32
	Subtest 2	23.75	23.74	23.76
	Subtest 3	23.36	23.35	23.37
	Subtest 4	23.08	23.07	23.09
	Subtest 5	22.89	22.88	22.9

Note:

- WCDMA SAR was tested under RMC 12.2kbps with HSPA Inactive per KDB Publication 941225 D01v03r01. HSPA SAR was not required since the average output power of the HSPA subtests was not more than 0.25dB higher than the RMC level and SAR was less than 1.2W/kg.
- It is expected by the manufacturer that MPR for some HSPA subtests may be up to 2dB more than specified by 3GPP, but also as low as 0dB according to the chipset implementation in this model

7.3 LTE Conducted peak output Power

LTE Test Configurations

The CMW500 Wide Band Radio Communication Tester was used for LTE output power measurements and SAR testing. Closed loop power control was used so the UE transmits with maximum output power during SAR testing. SAR test were performed with the same number of RB and RB offsets transmitting on all frames.

1) Spectrum Plots for RB configurations

A properly configured base station simulator was used for LTE output power measurements and SAR testing. Therefore, spectrum plots for RB configurations were not required to be included in this report.

2) MPR

When MPR is implemented permanently within the UE, regardless of network requirements, only those RB configurations allowed by 3GPP for the channel bandwidth and modulation combinations may be tested with MPR active. Configurations with RB allocations less than the RB thresholds required by 3GPP must be tested without MPR.

The allowed Maximum Power Reduction(MPR) for the maximum output power due to higher order modulation and transmit bandwidth configuration (resource blocks) is specified in Table 6.2.3-1 of the 3GPP TS36.101:

Table 6.2.3-1: Maximum Power Reduction (MPR) for Power Class 3

Modulation	Channel bandwidth / Transmission bandwidth configuration [RB]						MPR (dB)
	1.4 MHz	3.0 MHz	5 MHz	10 MHz	15 MHz	20 MHz	
QPSK	> 5	> 4	> 8	> 12	> 16	> 18	≤ 1
16 QAM	≤ 5	≤ 4	≤ 8	≤ 12	≤ 16	≤ 18	≤ 1
16 QAM	> 5	> 4	> 8	> 12	> 16	> 18	≤ 2

3)A-MPR LTE procedures for SAR testing

A-MPR(Additional MPR) has been disabled for all SAR tests by using Network Signaling Value of “NS_01” on the base station simulator.

4)LTE procedures for SAR testing

A) Largest channel bandwidthstandalone SARtestrequirements

i)QPSK with 1RBallocation

StartwiththelargestchannelbandwidthandmeasureSARfor

QPSKwith1RBallocation,usingtheRBoffsetandrequiredtestchannelcombinationwiththehighestmaximumoutp utpowerforRB offsets at the upper edge, middle and lower edge of each required test channel. When the reported SAR is $\leq 0.8\text{W/kg}$, testing of the remaining RB offset configurations and required test channels is not required for 1RB allocation; otherwise, SAR is required for the remaining required test channels and only for the RB offset configuration with the highest output power for that channel. When the reported SAR of a required test channel is $> 1.45\text{W/kg}$, SAR is required for all three RB offset configurations for that required test channel.



1. LTE Band 2 Conducted Power Test Verdict:

LTE FDD Band 2				Conducted Power(dBm)			Tune up
Bandwidth	Modulation	RB size	RB offset	Channel/Frequency			
				18607/1850.7	18900/1880	19193/1909.3	
1.4MHz	QPSK	1	0	21.22	21.38	21.2	20.5±1.0
		1	3	21.16	21.18	21.09	
		1	5	21.03	21.3	21.19	
		3	0	20.89	21.06	20.94	20.5±1.0
		3	2	20.74	20.93	20.92	
		3	3	20.75	20.99	20.81	
	6	0	20.47	20.73	20.55	20.0±1.0	
	16QAM	1	0	20	20.17	19.95	19.5±1.0
		1	3	19.94	19.97	19.84	
		1	5	19.81	20.09	19.94	
		3	0	19.67	19.85	19.69	19.5±1.0
		3	2	19.52	19.72	19.67	
		3	3	19.53	19.78	19.56	
		6	0	19.25	19.52	19.3	19.0±1.0
Bandwidth	Modulation	RB size	RB offset	Channel/Frequency			Tune up
3MHz	QPSK	1	0	21.29	21.43	21.28	20.5±1.0
		1	7	21.23	21.23	21.17	
		1	14	21.1	21.35	21.27	
		8	0	20.96	21.11	21.02	20.5±1.0
		8	4	20.81	20.98	21	
		8	7	20.82	21.04	20.89	
		15	0	20.54	20.78	20.63	20.0±1.0
	16QAM	1	0	20.07	20.22	20.03	19.5±1.0
		1	7	20.01	20.02	19.92	
		1	14	19.88	20.14	20.02	
		8	0	19.74	19.9	19.77	19.5±1.0
		8	4	19.59	19.77	19.75	
		8	7	19.6	19.83	19.64	
		15	0	19.32	19.57	19.38	19.0±1.0



LTE FDD Band 2				Conducted Power(dBm)				
Bandwidth	Modulation	RB size	RB offset	Channel/Frequency			Tune up	
				18625/1852.5	18900/1880	19175/1907.5		
5MHz	QPSK	1	0	21.34	21.46	21.32	20.5±1.0	
		1	13	21.28	21.26	21.21		
		1	24	21.15	21.38	21.31		
		12	0	21.01	21.14	21.06	20.5±1.0	
		12	6	20.86	21.01	21.04		
		12	13	20.87	21.07	20.93		
	25	0	20.59	20.81	20.67	20.0±1.0		
	16QAM	1	0	20.12	20.25	20.07	19.5±1.0	
		1	13	20.06	20.05	19.96		
		1	24	19.93	20.17	20.06		
		12	0	19.79	19.93	19.81	19.5±1.0	
		12	6	19.64	19.8	19.79		
		12	13	19.65	19.86	19.68		
		25	0	19.37	19.6	19.42	19.0±1.0	
Bandwidth	Modulation	RB size	RB offset	Channel/Frequency			Tune up	
10MHz	QPSK	1	0	21.39	21.49	21.36	20.5±1.0	
		1	25	21.33	21.29	21.25		
		1	49	21.2	21.41	21.35		
		25	0	21.06	21.17	21.1	20.5±1.0	
		25	13	20.91	21.04	21.08		
		25	25	20.92	21.1	20.97		
		50	0	20.64	20.84	20.71	20.0±1.0	
	16QAM	1	0	20.17	20.28	20.11	19.5±1.0	
		1	25	20.11	20.08	20		
		1	49	19.98	20.2	20.1		
		25	0	19.84	19.96	19.85	19.5±1.0	
		25	13	19.69	19.83	19.83		
		25	25	19.7	19.89	19.72		
		50	0	19.42	19.63	19.46	19.0±1.0	
	Bandwidth	Modulation	RB size	RB offset	18650/1855	18900/1880	19150/1905	Tune up



LTE FDD Band 2				Conducted Power(dBm)			
Bandwidth	Modulation	RB size	RB offset	Channel/Frequency			Tune up
				18675/1857.5	18900/1880	19125/1902.5	
15MHz	QPSK	1	0	21.45	21.53	21.42	20.8±1.0
		1	38	21.39	21.33	21.31	
		1	74	21.26	21.45	21.41	
		36	0	21.12	21.21	21.16	20.5±1.0
		36	18	20.97	21.08	21.14	
		36	39	20.98	21.14	21.03	
	75	0	20.7	20.88	20.77	20.0±1.0	
	16QAM	1	0	20.23	20.32	20.17	19.5±1.0
		1	38	20.17	20.12	20.06	
		1	74	20.04	20.24	20.16	
		36	0	19.9	20	19.91	19.5±1.0
		36	18	19.75	19.87	19.89	
		36	39	19.76	19.93	19.78	
		75	0	19.48	19.67	19.52	19.0±1.0
Bandwidth	Modulation	RB size	RB offset	Channel/Frequency			Tune up
20MHz	QPSK	1	0	21.53	21.66	21.48	20.8±1.0
		1	50	21.47	21.36	21.37	
		1	99	21.34	21.48	21.47	
		50	0	21.2	21.24	21.22	20.5±1.0
		50	25	21.05	21.11	21.2	
		50	50	21.06	21.17	21.09	
		100	0	20.78	20.91	20.83	20.0±1.0
	16QAM	1	0	20.31	20.45	20.23	19.5±1.0
		1	50	20.25	20.15	20.12	
		1	99	20.12	20.27	20.22	
		50	0	19.98	20.03	19.97	19.5±1.0
		50	25	19.83	19.9	19.95	
		50	50	19.84	19.96	19.84	
		100	0	19.56	19.7	19.58	19.0±1.0



2. LTE Band 4 Conducted Power Test Verdict:

LTE FDD Band 4				Conducted Power(dBm)			Tune up
Bandwidth	Modulation	RB size	RB offset	Channel/Frequency			
				19957/1710.7	20175/1732.5	20393/1754.3	
1.4MHz	QPSK	1	0	21.48	21.64	21.41	21.0±1.0
		1	3	21.42	21.25	21.31	
		1	5	21.16	21.51	21.44	
		3	0	20.98	21.13	20.86	20.5±1.0
		3	2	20.82	20.87	20.94	
		3	3	20.89	20.99	20.93	
		6	0	20.29	20.49	20.28	19.5±1.0
	16QAM	1	0	20.15	20.34	20.06	20.0±1.0
		1	3	20.09	19.95	19.96	
		1	5	19.83	20.21	20.09	
		3	0	19.65	19.83	19.51	19.5±1.0
		3	2	19.49	19.57	19.59	
		3	3	19.56	19.69	19.58	
		6	0	18.96	19.19	18.93	19.0±1.0
Bandwidth	Modulation	RB size	RB offset	Channel/Frequency			Tune up
3MHz	QPSK	1	0	21.54	21.69	21.46	21.0±1.0
		1	7	21.48	21.3	21.36	
		1	14	21.22	21.56	21.49	
		8	0	21.04	21.18	20.91	20.5±1.0
		8	4	20.88	20.92	20.99	
		8	7	20.95	21.04	20.98	
		15	0	20.35	20.54	20.33	19.5±1.0
	16QAM	1	0	20.21	20.39	20.11	20.0±1.0
		1	7	20.15	20	20.01	
		1	14	19.89	20.26	20.14	
		8	0	19.71	19.88	19.56	19.5±1.0
		8	4	19.55	19.62	19.64	
		8	7	19.62	19.74	19.63	
		15	0	19.02	19.24	18.98	19.0±1.0



LTE FDD Band 4				Conducted Power(dBm)			
Bandwidth	Modulation	RB size	RB offset	Channel/Frequency			Tune up
				19975/1712.5	20175/1732.5	20375/1752.5	
5MHz	QPSK	1	0	21.6	21.73	21.51	21.0±1.0
		1	13	21.54	21.34	21.41	
		1	24	21.28	21.6	21.54	
		12	0	21.1	21.22	20.96	20.5±1.0
		12	6	20.94	20.96	21.04	
		12	13	21.01	21.08	21.03	
		25	0	20.41	20.58	20.38	19.5±1.0
	16QAM	1	0	20.27	20.43	20.16	20.0±1.0
		1	13	20.21	20.04	20.06	
		1	24	19.95	20.3	20.19	
		12	0	19.77	19.92	19.61	19.5±1.0
		12	6	19.61	19.66	19.69	
		12	13	19.68	19.78	19.68	
		25	0	19.08	19.28	19.03	19.0±1.0
Bandwidth	Modulation	RB size	RB offset	Channel/Frequency			Tune up
10MHz	QPSK	1	0	21.66	21.77	21.56	21.0±1.0
		1	25	21.6	21.38	21.46	
		1	49	21.34	21.64	21.59	
		25	0	21.16	21.26	21.01	20.5±1.0
		25	13	21	21	21.09	
		25	25	21.07	21.12	21.08	
		50	0	20.47	20.62	20.43	19.5±1.0
	16QAM	1	0	20.33	20.47	20.21	20.0±1.0
		1	25	20.27	20.08	20.11	
		1	49	20.01	20.34	20.24	
		25	0	19.83	19.96	19.66	19.5±1.0
		25	13	19.67	19.7	19.74	
		25	25	19.74	19.82	19.73	
		50	0	19.14	19.32	19.08	19.0±1.0
Bandwidth	Modulation	RB size	RB offset	20000/1715	20175/1732.5	20350/1750	Tune up



LTE FDD Band 4				Conducted Power(dBm)			
Bandwidth	Modulation	RB size	RB offset	Channel/Frequency			Tune up
				20025/1717.5	20175/1732.5	20325/1747.5	
15MHz	QPSK	1	0	21.73	21.82	21.64	21.0±1.0
		1	38	21.67	21.43	21.54	
		1	74	21.41	21.69	21.67	
		36	0	21.23	21.31	21.09	20.5±1.0
		36	18	21.07	21.05	21.17	
		36	39	21.14	21.17	21.16	
		75	0	20.54	20.67	20.51	19.5±1.0
	16QAM	1	0	20.4	20.52	20.29	20.0±1.0
		1	38	20.34	20.13	20.19	
		1	74	20.08	20.39	20.32	
		36	0	19.9	20.01	19.74	19.5±1.0
		36	18	19.74	19.75	19.82	
		36	39	19.81	19.87	19.81	
		75	0	19.21	19.37	19.16	19.0±1.0
Bandwidth	Modulation	RB size	RB offset	Channel/Frequency			Tune up
				20050/1720	20175/1732.5	20300/1745	
20MHz	QPSK	1	0	21.76	21.86	21.67	21.0±1.0
		1	50	21.5	21.69	21.66	
		1	99	21.64	21.63	21.51	
		50	0	21.27	21.32	21.08	20.5±1.0
		50	25	21.07	21.18	21.16	
		50	50	21.08	21.14	21.01	
		100	0	20.61	20.74	20.52	19.5±1.0
	16QAM	1	0	20.43	20.56	20.32	20.0±1.0
		1	50	20.07	20.28	20.06	
		1	99	20.18	20.36	20.25	
		50	0	19.94	20.02	19.73	19.5±1.0
		50	25	19.82	19.71	19.7	
		50	50	19.87	19.79	19.67	
		100	0	19.28	19.44	19.17	19.0±1.0



3. LTE Band 5 Conducted Power Test Verdict:

LTE FDD Band 5				Conducted Power(dBm)			Tune up
Bandwidth	Modulation	RB size	RB offset	Channel/Frequency			
				20407/824.7	20525/836.5	20643/848.3	
1.4MHz	QPSK	1	0	21.43	21.55	21.48	20.8±1.0
		1	3	21.42	21.43	21.29	
		1	5	21.42	21.57	21.31	
		3	0	21.12	21.2	20.98	20.5±1.0
		3	2	20.88	20.96	21.03	
		3	3	20.98	21.07	21.05	
	6	0	20.6	20.75	20.73	20.0±1.0	
	16QAM	1	0	20.18	20.32	20.22	19.5±1.0
		1	3	20.14	20.18	20.02	
		1	5	20.14	20.32	20.04	
		3	0	19.84	19.97	19.68	19.5±1.0
		3	2	19.6	19.71	19.76	
		3	3	19.7	19.82	19.78	
	6	0	19.32	19.5	19.46	19.0±1.0	
Bandwidth	Modulation	RB size	RB offset	Channel/Frequency			Tune up
3MHz	QPSK	1	0	21.52	21.60	21.56	20.8±1.0
		1	7	21.51	21.48	21.37	
		1	14	21.51	21.62	21.39	
		8	0	21.21	21.25	21.06	20.5±1.0
		8	4	20.97	21.01	21.11	
		8	7	21.07	21.12	21.13	
	15	0	20.69	20.8	20.81	20.0±1.0	
	16QAM	1	0	20.27	20.37	20.3	19.5±1.0
		1	7	20.23	20.23	20.1	
		1	14	20.23	20.37	20.12	
		8	0	19.93	20.02	19.76	19.5±1.0
		8	4	19.69	19.76	19.84	
		8	7	19.79	19.87	19.86	
	15	0	19.41	19.55	19.54	19.0±1.0	



LTE FDD Band 5				Conducted Power(dBm)			
Bandwidth	Modulation	RB size	RB offset	Channel/Frequency			Tune up
				20425/826.5	20525/836.5	20625/846.5	
5MHz	QPSK	1	0	21.55	21.62	21.57	20.8±1.0
		1	13	21.53	21.48	21.45	
		1	24	21.48	21.41	21.55	
		12	0	21.21	21.27	21.03	20.5±1.0
		12	6	20.96	21.12	21.12	
		12	13	21.05	21.06	20.96	
	25	0	20.71	20.73	20.77	20.0±1.0	
	16QAM	1	0	20.27	20.37	20.3	19.5±1.0
		1	13	20.25	20.23	20.18	
		1	24	20.2	20.16	20.28	
		12	0	19.93	20.02	19.76	19.5±1.0
		12	6	19.68	19.87	19.85	
		12	13	19.77	19.81	19.69	
		25	0	19.43	19.48	19.5	19.0±1.0
Bandwidth	Modulation	RB size	RB offset	Channel/Frequency			Tune up
10MHz	QPSK	1	0	21.61	21.67	21.62	20.8±1.0
		1	25	21.59	21.53	21.5	
		1	49	21.54	21.46	21.6	
		25	0	21.27	21.32	21.08	20.5±1.0
		25	13	21.02	21.17	21.17	
		25	25	21.11	21.11	21.01	
	50	0	20.77	20.78	20.82	20.0±1.0	
	16QAM	1	0	20.33	20.42	20.35	19.5±1.0
		1	25	20.31	20.28	20.23	
		1	49	20.26	20.21	20.33	
		25	0	19.99	20.07	19.81	19.5±1.0
		25	13	19.74	19.92	19.9	
		25	25	19.83	19.86	19.74	
		50	0	19.49	19.53	19.55	19.0±1.0
Bandwidth	Modulation	RB size	RB offset	20450/829	20525/836.5	20600/844	Tune up



4. LTE Band 7 Conducted Power Test Verdict:

LTE FDD Band 7				Conducted Power(dBm)			Tune up
Bandwidth	Modulation	RB size	RB offset	Channel/Frequency			
				20775/2502.5	21100/2535	21425/2567.5	
5MHz	QPSK	1	0	21.32	21.46	21.41	20.5±1.0
		1	13	21.19	21.25	21.17	
		1	24	21.39	21.43	21.27	
		12	0	21.11	20.98	20.87	20.5±1.0
		12	6	20.77	20.87	20.94	
		12	13	20.82	20.86	20.78	
		25	0	20.51	20.61	20.61	20.0±1.0
	16QAM	1	0	20.04	20.21	20.14	19.5±1.0
		1	13	19.91	20	19.9	
		1	24	20.11	20.18	20	
		12	0	19.83	19.73	19.6	19.5±1.0
		12	6	19.49	19.62	19.67	
		12	13	19.54	19.61	19.51	
		25	0	19.23	19.36	19.34	19.0±1.0
Bandwidth	Modulation	RB size	RB offset	Channel/Frequency			Tune up
10MHz	QPSK	1	0	21.41	21.51	21.49	20.7±1.0
		1	25	21.28	21.3	21.25	
		1	49	21.48	21.48	21.35	
		25	0	21.2	21.03	20.95	20.5±1.0
		25	13	20.86	20.92	21.02	
		25	25	20.91	20.91	20.86	
		50	0	20.6	20.66	20.69	20.0±1.0
	16QAM	1	0	20.13	20.26	20.22	19.5±1.0
		1	25	20	20.05	19.98	
		1	49	20.2	20.23	20.08	
		25	0	19.92	19.78	19.68	19.5±1.0
		25	13	19.58	19.67	19.75	
		25	25	19.63	19.66	19.59	
		50	0	19.32	19.41	19.42	19.0±1.0



LTE FDD Band 7				Conducted Power(dBm)			
Bandwidth	Modulation	RB size	RB offset	Channel/Frequency			Tune up
				20825/2507.5	21100/2535	21375/2562.5	
15MHz	QPSK	1	0	21.5	21.56	21.57	20.7±1.0
		1	38	21.37	21.35	21.33	
		1	74	21.57	21.53	21.43	
		36	0	21.29	21.08	21.03	20.5±1.0
		36	18	20.95	20.97	21.1	
		36	39	21	20.96	20.94	
		75	0	20.69	20.71	20.77	20.0±1.0
	16QAM	1	0	20.22	20.31	20.3	19.5±1.0
		1	38	20.09	20.1	20.06	
		1	74	20.29	20.28	20.16	
		36	0	20.01	19.83	19.76	19.5±1.0
		36	18	19.67	19.72	19.83	
		36	39	19.72	19.71	19.67	
		75	0	19.41	19.46	19.5	19.0±1.0
Bandwidth	Modulation	RB size	RB offset	Channel/Frequency			Tune up
				20850/2510	21100/2535	21350/2560	
20MHz	QPSK	1	0	21.59	21.61	21.65	20.7±1.0
		1	50	21.46	21.4	21.41	
		1	99	21.66	21.58	21.51	
		50	0	21.38	21.13	21.11	20.5±1.0
		50	25	21.04	21.02	21.18	
		50	50	21.09	21.01	21.02	
		100	0	20.78	20.76	20.85	20.0±1.0
	16QAM	1	0	20.31	20.36	20.38	19.5±1.0
		1	50	20.18	20.15	20.14	
		1	99	20.38	20.33	20.24	
		50	0	20.1	19.88	19.84	19.5±1.0
		50	25	19.76	19.77	19.91	
		50	50	19.81	19.76	19.75	
		100	0	19.5	19.51	19.58	19.0±1.0



5. LTE Band 12 Conducted Power Test Verdict:

LTE FDD Band 12				Conducted Power(dBm)			Tune up
Bandwidth	Modulation	RB size	RB offset	Channel/Frequency			
				23017/699.7	23095/707.5	23173/715.3	
1.4MHz	QPSK	1	0	21.58	21.61	21.43	21.0±1.0
		1	3	21.25	21.5	21.41	
		1	5	21.25	21.5	21.34	
		3	0	20.98	21.15	20.94	20.5±1.0
		3	2	20.9	20.86	20.87	
		3	3	20.8	20.86	20.94	
		6	0	20.55	20.68	20.51	20.0±1.0
	16QAM	1	0	20.3	20.36	20.16	20.0±1.0
		1	3	19.99	20.05	20.16	
		1	5	20.12	20.03	20.05	
		3	0	19.7	19.9	19.67	19.5±1.0
		3	2	19.62	19.61	19.6	
		3	3	19.52	19.61	19.67	
		6	0	19.27	19.43	19.24	19.0±1.0
Bandwidth	Modulation	RB size	RB offset	Channel/Frequency			Tune up
3MHz	QPSK	1	0	21.67	21.66	21.51	21.0±1.0
		1	7	21.34	21.55	21.49	
		1	14	21.34	21.55	21.42	
		8	0	21.07	21.2	21.02	20.5±1.0
		8	4	20.99	20.91	20.95	
		8	7	20.89	20.91	21.02	
		15	0	20.64	20.73	20.59	20.0±1.0
	16QAM	1	0	20.39	20.41	20.24	20.0±1.0
		1	7	20.08	20.1	20.24	
		1	14	20.21	20.08	20.13	
		8	0	19.79	19.95	19.75	19.5±1.0
		8	4	19.71	19.66	19.68	
		8	7	19.61	19.66	19.75	
		15	0	19.36	19.48	19.32	19.0±1.0



LTE FDD Band 12				Conducted Power(dBm)			
Bandwidth	Modulation	RB size	RB offset	Channel/Frequency			Tune up
				23035/701.5	23095/707.5	23155/713.5	
5MHz	QPSK	1	0	21.76	21.71	21.59	21.0±1.0
		1	13	21.43	21.6	21.57	
		1	24	21.43	21.6	21.5	
		12	0	21.16	21.25	21.1	20.5±1.0
		12	6	21.08	20.96	21.03	
		12	13	20.98	20.96	21.1	
	25	0	20.73	20.78	20.67	20.0±1.0	
	16QAM	1	0	20.48	20.46	20.32	20.0±1.0
		1	13	20.17	20.15	20.32	
		1	24	20.3	20.13	20.21	
		12	0	19.88	20	19.83	19.5±1.0
		12	6	19.8	19.71	19.76	
		12	13	19.7	19.71	19.83	
		25	0	19.45	19.53	19.4	19.0±1.0
Bandwidth	Modulation	RB size	RB offset	Channel/Frequency			Tune up
				23060/704	23095/707.5	23130/711	
10MHz	QPSK	1	0	21.85	21.76	21.67	21.0±1.0
		1	25	21.52	21.65	21.65	
		1	49	21.52	21.65	21.58	
		25	0	21.25	21.30	21.18	20.5±1.0
		25	13	21.17	21.01	21.11	
		25	25	21.07	21.01	21.18	
		50	0	20.82	20.83	20.75	20.0±1.0
	16QAM	1	0	20.57	20.51	20.40	20.0±1.0
		1	25	20.26	20.20	20.40	
		1	49	20.39	20.18	20.29	
		25	0	19.97	20.05	19.91	19.5±1.0
		25	13	19.89	19.76	19.84	
		25	25	19.79	19.76	19.91	
		50	0	19.54	19.58	19.48	19.0±1.0



6. LTE Band 17 Conducted Power Test Verdict:

LTE FDD Band 17				Conducted Power(dBm)			Tune up
Bandwidth	Modulation	RB size	RB offset	Channel/Frequency			
				23755/706.5	23790/710	23825/713.5	
5MHz	QPSK	1	0	21.59	21.76	21.68	21.0±1.0
		1	13	21.49	21.51	21.57	
		1	24	21.34	21.63	21.44	
		12	0	21.23	21.08	21.23	20.5±1.0
		12	6	21.1	21.02	21.07	
		12	13	20.98	21.03	21.1	
	16QAM	25	0	20.69	20.84	20.68	20.0±1.0
		1	0	20.31	20.51	20.41	20.0±1.0
		1	13	20.21	20.26	20.3	
		1	24	20.06	20.38	20.17	
		12	0	19.95	19.83	19.96	19.5±1.0
		12	6	19.82	19.77	19.8	
		12	13	19.7	19.78	19.83	
		25	0	19.41	19.59	19.41	19.0±1.0
Bandwidth	Modulation	RB size	RB offset	Channel/Frequency			Tune up
				23780/709	23790/710	23800/711	
10MHz	QPSK	1	0	21.68	21.81	21.76	21.0±1.0
		1	25	21.58	21.56	21.65	
		1	49	21.43	21.68	21.52	
		25	0	21.32	21.13	21.31	20.5±1.0
		25	13	21.19	21.07	21.15	
		25	25	21.07	21.08	21.18	
	16QAM	50	0	20.78	20.89	20.76	20.0±1.0
		1	0	20.4	20.56	20.49	20.0±1.0
		1	25	20.3	20.31	20.38	
		1	49	20.15	20.43	20.25	
		25	0	20.04	19.88	20.04	19.5±1.0
		25	13	19.91	19.82	19.88	
		25	25	19.79	19.83	19.91	
		50	0	19.5	19.64	19.49	19.0±1.0



7. LTE Band 41 Conducted Power Test Verdict:

LTE FDD Band 41				Conducted Power(dBm)			Tune up
Bandwidth	Modulation	RB size	RB offset	Channel/Frequency			
				39675/2498.5	40620/2593	41565/2687.5	
5MHz	QPSK	1	0	21.14	21.3	21.18	20.5±1.0
		1	13	21.13	21.17	21.12	
		1	24	20.93	21.22	20.97	
		12	0	20.97	21.13	21.08	20.5±1.0
		12	6	20.89	21.05	20.91	
		12	13	20.86	20.97	20.77	
		25	0	20.49	20.65	20.55	20.0±1.0
	16QAM	1	0	19.86	20.05	19.91	19.5±1.0
		1	13	19.85	19.92	19.85	
		1	24	19.65	19.97	19.7	
		12	0	19.69	19.88	19.81	19.5±1.0
		12	6	19.61	19.8	19.64	
		12	13	19.58	19.72	19.5	
		25	0	19.21	19.4	19.28	19.0±1.0
Bandwidth	Modulation	RB size	RB offset	Channel/Frequency			Tune up
10MHz	QPSK	1	0	21.23	21.35	21.26	20.5±1.0
		1	25	21.22	21.22	21.2	
		1	49	21.02	21.27	21.05	
		25	0	21.06	21.18	21.16	20.5±1.0
		25	13	20.98	21.1	20.99	
		25	25	20.95	21.02	20.85	
		50	0	20.58	20.7	20.63	20.0±1.0
	16QAM	1	0	19.95	20.1	19.99	19.5±1.0
		1	25	19.94	19.97	19.93	
		1	49	19.74	20.02	19.78	
		25	0	19.78	19.93	19.89	19.5±1.0
		25	13	19.7	19.85	19.72	
		25	25	19.67	19.77	19.58	
		50	0	19.3	19.45	19.36	19.0±1.0



LTE FDD Band 41				Conducted Power(dBm)			
Bandwidth	Modulation	RB size	RB offset	Channel/Frequency			Tune up
				39725/2503.5	40620/2593	41515/2682.5	
15MHz	QPSK	1	0	21.32	21.4	21.34	20.5±1.0
		1	38	21.31	21.27	21.28	
		1	74	21.11	21.32	21.13	
		36	0	21.15	21.23	21.24	20.5±1.0
		36	18	21.07	21.15	21.07	
		36	39	21.04	21.07	20.93	
		75	0	20.67	20.75	20.71	20.0±1.0
	16QAM	1	0	20.04	20.15	20.07	19.5±1.0
		1	38	20.03	20.02	20.01	
		1	74	19.83	20.07	19.86	
		36	0	19.87	19.98	19.97	19.5±1.0
		36	18	19.79	19.9	19.8	
		36	39	19.76	19.82	19.66	
		75	0	19.39	19.5	19.44	19.0±1.0
Bandwidth	Modulation	RB size	RB offset	Channel/Frequency			Tune up
				39750/2506	40620/2593	41490/2680	
20MHz	QPSK	1	0	21.41	21.45	21.42	20.5±1.0
		1	50	21.4	21.32	21.36	
		1	99	21.2	21.37	21.21	
		50	0	21.24	21.28	21.32	20.5±1.0
		50	25	21.16	21.2	21.15	
		50	50	21.13	21.12	21.01	
		100	0	20.76	20.8	20.79	20.0±1.0
	16QAM	1	0	20.13	20.2	20.15	19.5±1.0
		1	50	20.12	20.07	20.09	
		1	99	19.92	20.12	19.94	
		50	0	19.96	20.03	20.05	19.5±1.0
		50	25	19.88	19.95	19.88	
		50	50	19.85	19.87	19.74	
		100	0	19.48	19.55	19.52	19.0±1.0



8. LTE Band 66 Conducted Power Test Verdict:

LTE FDD Band 66				Conducted Power(dBm)			Tune up
Bandwidth	Modulation	RB size	RB offset	Channel/Frequency			
				131979/1710.7	132322/1745	132665/1779.3	
1.4MHz	QPSK	1	0	21.07	21.18	20.95	20.5±1.0
		1	3	20.89	21.18	20.96	
		1	5	20.98	21.12	20.98	
		3	0	20.64	20.68	20.45	20.0±1.0
		3	2	20.58	20.69	20.41	
		3	3	20.51	20.53	20.35	
		6	0	20.34	20.45	20.22	20.0±1.0
	16QAM	1	0	20.07	20.08	19.85	19.5±1.0
		1	3	20.1	20.22	20.04	
		1	5	19.96	20.2	19.89	
		3	0	19.71	19.8	19.59	19.5±1.0
		3	2	19.72	19.81	19.6	
		3	3	19.8	19.71	19.68	
		6	0	19.45	19.55	19.42	19.0±1.0
Bandwidth	Modulation	RB size	RB offset	Channel/Frequency			Tune up
3MHz	QPSK	1	0	21.12	21.21	21.01	20.5±1.0
		1	7	20.94	21.21	21.02	
		1	14	21.03	21.15	21.04	
		8	0	20.69	20.71	20.51	20.0±1.0
		8	4	20.63	20.72	20.47	
		8	7	20.56	20.56	20.41	
		15	0	20.39	20.48	20.28	20.0±1.0
	16QAM	1	0	20.12	20.11	19.91	19.5±1.0
		1	7	20.15	20.25	20.1	
		1	14	20.01	20.23	19.95	
		8	0	19.76	19.83	19.65	19.5±1.0
		8	4	19.77	19.84	19.66	
		8	7	19.85	19.74	19.74	
		15	0	19.5	19.58	19.48	19.0±1.0



LTE FDD Band 66				Conducted Power(dBm)			
Bandwidth	Modulation	RB size	RB offset	Channel/Frequency			Tune up
				131997/1712.5	132322/1745	132647/1777.5	
5MHz	QPSK	1	0	21.17	21.24	21.07	20.5±1.0
		1	13	20.99	21.24	21.08	
		1	24	21.08	21.18	21.1	
		12	0	20.74	20.74	20.57	20.0±1.0
		12	6	20.68	20.75	20.53	
		12	13	20.61	20.59	20.47	
		25	0	20.44	20.51	20.34	20.0±1.0
	16QAM	1	0	20.17	20.14	19.97	19.5±1.0
		1	13	20.2	20.28	20.16	
		1	24	20.06	20.26	20.01	
		12	0	19.81	19.86	19.71	19.5±1.0
		12	6	19.82	19.87	19.72	
		12	13	19.9	19.77	19.8	
		25	0	19.55	19.61	19.54	19.0±1.0
Bandwidth	Modulation	RB size	RB offset	Channel/Frequency			Tune up
10MHz	QPSK	1	0	21.23	21.28	21.15	20.5±1.0
		1	25	21.05	21.28	21.16	
		1	49	21.14	21.22	21.18	
		25	0	20.8	20.78	20.65	20.0±1.0
		25	13	20.74	20.79	20.61	
		25	25	20.67	20.63	20.55	
		50	0	20.5	20.55	20.42	20.0±1.0
	16QAM	1	0	20.23	20.18	20.05	19.5±1.0
		1	25	20.26	20.32	20.24	
		1	49	20.12	20.3	20.09	
		25	0	19.87	19.9	19.79	19.5±1.0
		25	13	19.88	19.91	19.8	
		25	25	19.96	19.81	19.88	
		50	0	19.61	19.65	19.62	19.0±1.0
Bandwidth	Modulation	RB size	RB offset	132022/1715	132322/1745	132622/1775	Tune up



LTE FDD Band 66				Conducted Power(dBm)			
Bandwidth	Modulation	RB size	RB offset	Channel/Frequency			Tune up
				132047/1717.5	132322/1745	132597/1772.5	
15MHz	QPSK	1	0	21.29	21.32	21.23	20.5±1.0
		1	38	21.11	21.32	21.24	
		1	74	21.2	21.26	21.26	
		36	0	20.86	20.82	20.73	20.0±1.0
		36	18	20.8	20.83	20.69	
		36	39	20.73	20.67	20.63	
		75	0	20.56	20.59	20.5	20.0±1.0
	16QAM	1	0	20.29	20.22	20.13	19.5±1.0
		1	38	20.32	20.36	20.32	
		1	74	20.18	20.34	20.17	
		36	0	19.93	19.94	19.87	19.5±1.0
		36	18	19.94	19.95	19.88	
		36	39	20.02	19.85	19.96	
		75	0	19.67	19.69	19.7	19.0±1.0
Bandwidth	Modulation	RB size	RB offset	Channel/Frequency			Tune up
20MHz	QPSK	1	0	21.35	21.36	21.31	20.5±1.0
		1	50	21.17	21.36	21.32	
		1	99	21.26	21.3	21.34	
		50	0	20.92	20.86	20.81	20.0±1.0
		50	25	20.86	20.87	20.77	
		50	50	20.79	20.71	20.71	
		100	0	20.62	20.63	20.58	20.0±1.0
	16QAM	1	0	20.35	20.26	20.21	19.5±1.0
		1	50	20.38	20.4	20.4	
		1	99	20.24	20.38	20.25	
		50	0	19.99	19.98	19.95	19.5±1.0
		50	25	20	19.99	19.96	
		50	50	20.08	19.89	20.04	
		100	0	19.73	19.73	19.78	19.0±1.0
Bandwidth	Modulation	RB size	RB offset	132072/1720	132322/1745	132572/1770	Tune up



9. LTE Band 71 Conducted Power Test Verdict:

LTE FDD Band 71				Conducted Power(dBm)			Tune up
Bandwidth	Modulation	RB size	RB offset	Channel/Frequency			
				133147/665.5	133297/680.5	133447/695.5	
5MHz	QPSK	1	0	22.09	22.17	21.95	21.5±1.0
		1	13	22.13	21.91	21.98	
		1	24	22.03	22.12	22.11	
		12	0	21.8	21.78	21.65	21.0±1.0
		12	6	21.69	21.72	21.78	
		12	13	21.73	21.84	21.84	
		25	0	21.48	21.48	21.49	20.5±1.0
	16QAM	1	0	21.27	21.3	21.1	20.5±1.0
		1	13	21.09	21.09	21.25	
		1	24	21.15	21.22	21.23	
		12	0	20.9	20.96	20.81	20.0±1.0
		12	6	20.92	20.98	20.72	
		12	13	20.9	20.81	20.8	
		25	0	20.56	20.55	20.56	20.0±1.0
Bandwidth	Modulation	RB size	RB offset	Channel/Frequency			Tune up
10MHz	QPSK	1	0	22.14	21.91	21.98	21.5±1.0
		1	25	22.04	21.97	21.94	
		1	49	22.11	21.94	21.99	
		25	0	21.61	21.84	21.65	21.0±1.0
		25	13	21.7	21.6	21.8	
		25	25	21.68	21.84	21.79	
		50	0	21.46	21.45	21.47	20.5±1.0
	16QAM	1	0	21.15	21.14	21.09	20.5±1.0
		1	25	21.27	21.18	21.33	
		1	49	21.27	21.07	21.07	
		25	0	20.78	20.72	20.79	20.5±1.0
		25	13	20.72	21	20.82	
		25	25	20.95	20.76	20.74	
		50	0	20.64	20.61	20.59	20.0±1.0



LTE FDD Band 71				Conducted Power(dBm)			
Bandwidth	Modulation	RB size	RB offset	Channel/Frequency			Tune up
				133197/670.5	133297/680.5	133397/690.5	
15MHz	QPSK	1	0	21.91	22.03	21.99	21.5±1.0
		1	38	21.98	22.13	21.94	
		1	74	22.11	21.97	21.94	
		36	0	21.61	21.56	21.66	21.0±1.0
		36	18	21.76	21.66	21.84	
		36	39	21.57	21.75	21.61	
		75	0	21.49	21.42	21.48	20.5±1.0
	16QAM	1	0	21.26	21.29	21.33	20.5±1.0
		1	38	21.3	21.05	21.14	
		1	74	21.15	21.17	21.32	
		36	0	20.85	20.89	20.81	20.5±1.0
		36	18	20.8	20.82	20.79	
		36	39	20.78	20.99	21	
		75	0	20.61	20.65	20.59	20.0±1.0
Bandwidth	Modulation	RB size	RB offset	Channel/Frequency			Tune up
				133222/673.0	133322/683.0	133372/688.0	
20MHz	QPSK	1	0	22.19	22.26	22.21	21.5±1.0
		1	50	22.08	22.02	22.08	
		1	99	22.02	21.94	22	
		50	0	21.78	21.82	21.66	21.0±1.0
		50	25	21.8	21.76	21.64	
		50	50	21.69	21.66	21.65	
		100	0	21.42	21.47	21.43	20.5±1.0
	16QAM	1	0	21.13	21.31	21.26	20.5±1.0
		1	50	21.27	21.23	21.3	
		1	99	21.35	21.28	21.11	
		50	0	21	20.76	20.77	20.5±1.0
		50	25	20.7	20.94	20.73	
		50	50	20.95	20.75	20.95	
		100	0	20.56	20.56	20.62	20.0±1.0

7.4 WIFI Conducted Power

WLAN 2.4GHz Band Conducted Power

Channel/Freq.(MHz)	Maximum Conducted Out Power (dBm)		
	802.11b	802.11g	802.11n(HT20)
1(2412)	18.00	15.74	14.03
6(2437)	17.45	14.60	12.79
11(2462)	17.70	15.70	13.77

WLAN 5GHz Band Conducted Power

U-NII-1 AVGSA Output Power

Mode	Test Frequency (MHz)	Max Power (dBm)
802.11n (20MHz)	5180	14.89
802.11n (20MHz)	5220	14.87
802.11n (20MHz)	5240	15.43
802.11n (40MHz)	5190	14.38
802.11n (40MHz)	5230	14.61
802.11ac (20MHz)	5180	14.55
802.11ac (20MHz)	5220	14.24
802.11ac (20MHz)	5240	14.99
802.11ac (40MHz)	5190	14.23
802.11ac (40MHz)	5230	14.77
802.11ac (80MHz)	5210	12.93
802.11a (20MHz)	5180	14.68
802.11a (20MHz)	5220	14.42
802.11a (20MHz)	5240	15.05



U-NII-2a AVGSA Output Power

Mode	Test Frequency (MHz)	Max Power (dBm)
802.11n (20MHz)	5260	14.75
802.11n (20MHz)	5300	14.40
802.11n (20MHz)	5320	14.31
802.11n (40MHz)	5270	14.50
802.11n (40MHz)	5310	13.86
802.11ac (20MHz)	5260	13.19
802.11ac (20MHz)	5300	14.41
802.11ac (20MHz)	5320	14.40
802.11ac (40MHz)	5270	14.24
802.11ac (40MHz)	5310	13.91
802.11ac (80MHz)	5290	12.80
802.11a (20MHz)	5260	14.69
802.11a (20MHz)	5300	14.48
802.11a (20MHz)	5320	14.29

U-NII-2c AVGSA Output Power

Mode	Test Frequency (MHz)	Max Power (dBm)
802.11n (20MHz)	5500	14.51
802.11n (20MHz)	5580	13.78
802.11n (20MHz)	5700	16.67
802.11n (40MHz)	5510	13.79
802.11n (40MHz)	5670	14.20
802.11ac (20MHz)	5500	14.66
802.11ac (20MHz)	5580	15.63
802.11ac (20MHz)	5700	16.74
802.11ac (40MHz)	5510	13.93
802.11ac (40MHz)	5670	13.72
802.11ac (80MHz)	5530	12.83
802.11a (20MHz)	5500	14.56
802.11a (20MHz)	5580	15.85
802.11a (20MHz)	5700	14.65



U-NII-3 AVGSA Output Power

Mode	Test Frequency (MHz)	Max Power (dBm)
802.11n (20MHz)	5745	13.75
802.11n (20MHz)	5785	13.85
802.11n (20MHz)	5825	13.64
802.11n (40MHz)	5755	13.86
802.11n (40MHz)	5795	13.75
802.11ac (20MHz)	5745	13.72
802.11ac (20MHz)	5785	13.76
802.11ac (20MHz)	5825	13.65
802.11ac (40MHz)	5755	13.55
802.11ac (40MHz)	5795	13.56
802.11ac (80MHz)	5775	12.16
802.11a (20MHz)	5745	14.05
802.11a (20MHz)	5785	14.07
802.11a (20MHz)	5825	13.76

7.5 Bluetooth Output Power

Channel	Frequency (MHz)	BT3.0 Output Power(dBm)		
		GFSK	$\pi/4$ -DQPSK	8-DPSK
CH 0	2402	7.59	7.66	10.51
CH 39	2441	8.33	8.45	10.43
CH 78	2480	6.44	6.53	9.88
Channel	Frequency (MHz)	BT4.0 Output Power(dBm)		
		GFSK		
CH 0	2402	1.369		
CH 20	2442	0.535		
CH 39	2480	0.072		

Note:

1. Per KDB248227 D01 v02r02, choose the highest output power channel to test SAR and determine further SAR exclusion
2. For each frequency band, testing at higher data rates and higher order modulations is not required when the maximum average output power for each of these configurations is less than 1/4dB higher than those measured at lowest data rate
3. Per KDB248227 D01 v02r02, 802.11g /11n-HT20/11n-HT40 is not required.. When the highest reported SAR for DSSS is adjusted by the ratio of OFDM to DSSS specified maximum output power and the adjusted SAR is $\leq 1.2\text{W/Kg}$. Thus the SAR can be excluded.

Antenna Location:

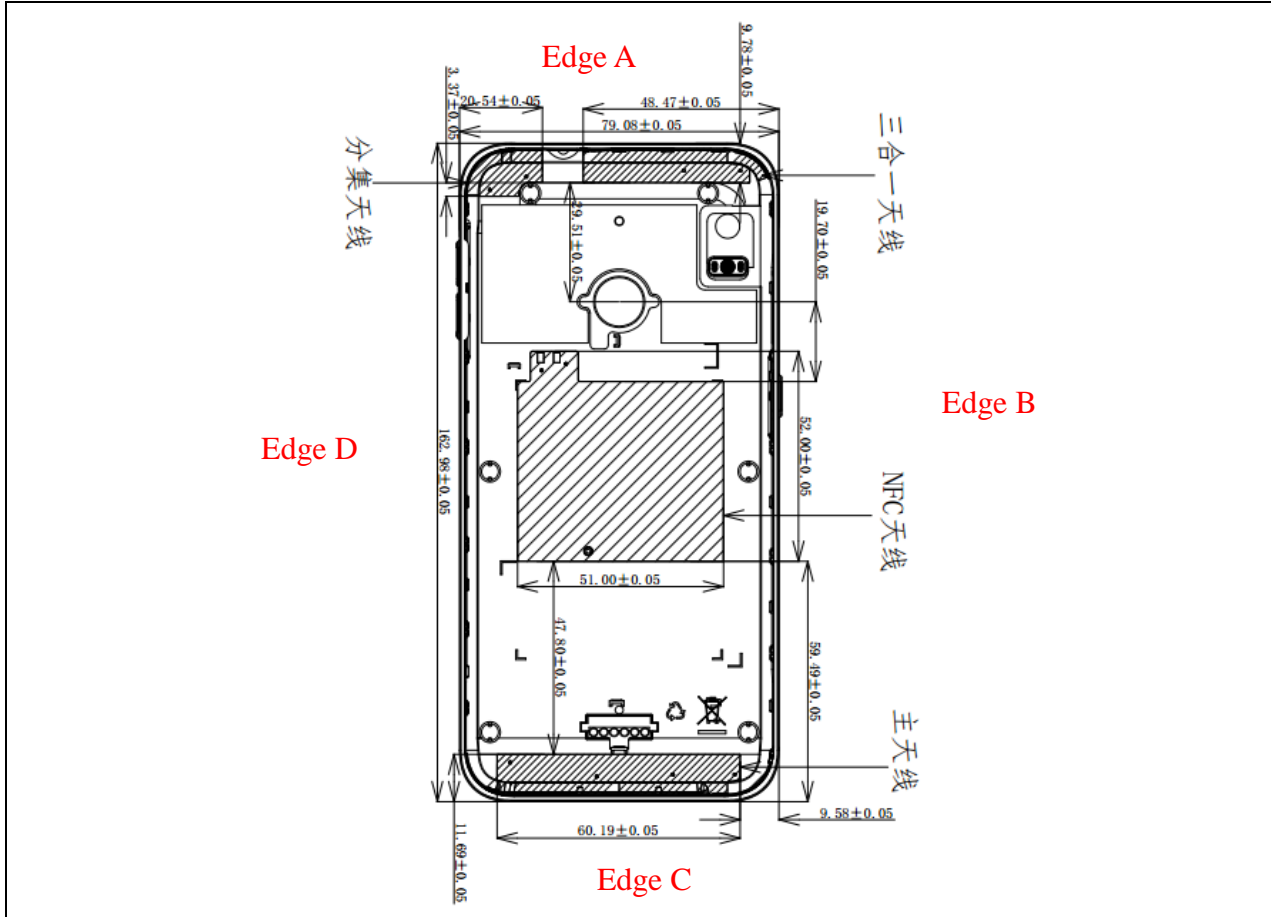

Antenna-to-User (Edge Side) distance (mm):

Antenna	Front	Back	Edge A	Edge B	Edge C	Edge D
WWAN Main Antenna	6	2	151	10	2	10
WIFI/BT	6	2	2	2	153	31

Note: The diagonal distance of the overall section is 15.5cm.

The Body SAR measurement positions of each band are as below:

Antenna	Front	Back	Edge A	Edge B	Edge C	Edge D
WWAN Antenna Body-worn	Yes	Yes	No	No	No	No
WWAN Antenna hotspot	Yes	Yes	No	Yes	Yes	Yes
WIFI Antenna Body-worn	Yes	Yes	No	No	No	No
WIFI 2.4G Antenna hotspot	Yes	Yes	Yes	Yes	No	No

Note: According to KDB 941225 D06 v02r01, when antenna-to-edge>2.5cm, SAR is not required.

8. Scaling Factor calculation

Operation Mode	Channel /Frequency	Output Power(dBm)	Tune up Power in tolerance (dBm)	Max. Tune up(dBm)	Scaling Factor
GSM850	128/824.2	32.97	32.1 ± 1.0	33.10	1.030
	190/836.6	32.89	32.1 ± 1.0	33.10	1.050
	251/848.8	33.01	32.1 ± 1.0	33.10	1.021
GPRS850 (GPRS 4Tx)	128/824.2	27.32	26.5 ± 1.0	27.50	1.042
	190/836.6	27.47	26.5 ± 1.0	27.50	1.007
	251/848.8	27.41	26.5 ± 1.0	27.50	1.021
GSM1900	512/1850.2	30.12	29.5 ± 1.0	30.50	1.091
	661/1880.0	30.36	29.5 ± 1.0	30.50	1.033
	810/1909.8	30.47	29.5 ± 1.0	30.50	1.007
GPRS1900 (GPRS 4Tx)	512/1850.2	24.51	23.9 ± 1.0	24.90	1.094
	661/1880.0	24.72	23.9 ± 1.0	24.90	1.042
	810/1909.8	24.63	23.9 ± 1.0	24.90	1.064
WCDMA850	4132/826.4	23.98	23.0 ± 1.0	24.00	1.005
	4183/836.6	23.89	23.0 ± 1.0	24.00	1.026
	4233/846.6	23.94	23.0 ± 1.0	24.00	1.014
WCDMA1900	9262/1852.4	24.35	23.5 ± 1.0	24.50	1.035
	9400/1880.0	24.25	23.5 ± 1.0	24.50	1.059
	9538/1907.6	24.30	23.5 ± 1.0	24.50	1.047
WCDMA1700	1312/1712.4	24.51	24.0 ± 1.0	25.00	1.119
	1413/1732.6	24.38	24.0 ± 1.0	25.00	1.153
	1513/1752.6	24.56	24.0 ± 1.0	25.00	1.107
LTE B2 20MHz 1RB#50	18700/1860	21.53	21.0 ± 1.0	22.00	1.114
	18900/1880	21.66	21.0 ± 1.0	22.00	1.081
	19100/1900	21.48	21.0 ± 1.0	22.00	1.127
LTE B2 20MHz 50RB#0	18700/1860	21.20	20.5 ± 1.0	21.50	1.072
	18900/1880	21.24	20.5 ± 1.0	21.50	1.062
	19100/1900	21.22	20.5 ± 1.0	21.50	1.067
LTE B4 20MHz 1RB#50	20050/1720	21.76	21.0 ± 1.0	22.00	1.057
	20175/1732.5	21.86	21.0 ± 1.0	22.00	1.033
	20300/1745	21.67	21.0 ± 1.0	22.00	1.079
LTE B4 20MHz 50RB#0	20050/1720	21.27	20.5 ± 1.0	21.50	1.054
	20175/1732.5	21.32	20.5 ± 1.0	21.50	1.042
	20300/1745	21.08	20.5 ± 1.0	21.50	1.102



LTE B5 10MHz 1RB#25	20450/829	21.61	21.0±1.0	22.00	1.094
	20525/836.5	21.67	21.0±1.0	22.00	1.079
	20600/844	21.62	21.0±1.0	22.00	1.091
LTE B5 10MHz 25RB#25	20450/829	21.27	20.5 ±1.0	21.50	1.054
	20525/836.5	21.32	20.5 ±1.0	21.50	1.042
	20600/844	21.08	20.5 ±1.0	21.50	1.102
LTE B7 20MHz 1RB#50	20850/2510	21.59	21.0±1.0	22.00	1.099
	21100/2535	21.61	21.0±1.0	22.00	1.094
	21350/2560	21.65	21.0±1.0	22.00	1.084
LTE B7 20MHz 50RB#25	20850/2510	21.38	20.5 ±1.0	21.50	1.028
	21100/2535	21.13	20.5 ±1.0	21.50	1.089
	21350/2560	21.11	20.5 ±1.0	21.50	1.094
LTE B12 10MHz 1RB#25	23060/704	21.85	21.0±1.0	22.00	1.035
	23095/707.5	21.76	21.0±1.0	22.00	1.057
	23130/711	21.67	21.0±1.0	22.00	1.079
LTE B12 10MHz 25RB#25	23060/704	21.25	20.5 ±1.0	21.50	1.059
	23095/707.5	21.30	20.5 ±1.0	21.50	1.047
	23130/711	21.18	20.5 ±1.0	21.50	1.076
LTE B17 10MHz 1RB#0	23780/709	21.68	21.0±1.0	22.00	1.076
	23790/710	21.81	21.0±1.0	22.00	1.045
	23800/711	21.76	21.0±1.0	22.00	1.057
LTE B17 10MHz 25RB#0	23780/709	21.32	20.5 ±1.0	21.50	1.042
	23790/710	21.13	20.5 ±1.0	21.50	1.089
	23800/711	21.31	20.5 ±1.0	21.50	1.045
LTE B41 20MHz 1RB#0	39750/2506	21.41	20.5 ±1.0	21.50	1.021
	40620/2593	21.45	20.5 ±1.0	21.50	1.012
	41490/2680	21.42	20.5 ±1.0	21.50	1.019
LTE B41 20MHz 50RB#0	39750/2506	21.24	20.5 ±1.0	21.50	1.062
	40620/2593	21.28	20.5 ±1.0	21.50	1.052
	41490/2680	21.32	20.5 ±1.0	21.50	1.042
LTE B66 20MHz 1RB#50	132072/1720	21.35	20.5 ±1.0	21.50	1.035
	132322/1745	21.36	20.5 ±1.0	21.50	1.033
	132572/1770	21.31	20.5 ±1.0	21.50	1.045
LTE B66 20MHz 50RB#0	132072/1720	20.92	20.0 ±1.0	21.00	1.019
	132322/1745	20.86	20.0 ±1.0	21.00	1.033
	132572/1770	20.81	20.0 ±1.0	21.00	1.045



LTE B71 20MHz 1RB#0	133222/673	22.19	21.5 ±1.0	22.5	1.074
	133322/683	22.26	21.5 ±1.0	22.5	1.057
	133372/688	22.21	21.5 ±1.0	22.5	1.069
LTE B71 20MHz 50RB#0	133222/673	21.80	21.0 ±1.0	22.0	1.047
	133322/683	21.82	21.0 ±1.0	22.0	1.042
	133372/688	21.66	21.0 ±1.0	22.0	1.081
WIFI 2.4G 802.11b	1/2412	18.00	17.0 ±1.0	18.00	1.000
	6/2437	17.45	17.0 ±1.0	18.00	1.135
	11/2462	17.70	17.0 ±1.0	18.00	1.072
BT 3.0 GFSK	0/2402	10.51	9.6 ±1.0	10.60	1.021
	39/2441	10.43	9.6 ±1.0	10.60	1.040
	78/2480	9.88	9.6 ±1.0	10.60	1.180
WIFI 5G BAND I	48/5240	15.43	14.5 ±1.0	15.50	1.016
WIFI 5G BANDII	52/5260	14.75	14.0 ±1.0	15.00	1.059
WIFI5G BANDIII	140/5700	16.74	16.0 ±1.0	17.00	1.062
WIFI5G BANDIV	157/5785	14.07	13.1 ±1.0	14.10	1.007

Note: for LTE power tolerance, only QPSK modulation mode was provide here.

9. Test Results

Results overview of GSM850

Test Position of Head	Channel /Frequency	Mode	SAR Value (W/kg)1-g	Power drift(%)	Scaled Factor	Scaled SAR (W/Kg)1-g	SAR Plot.
Right Cheek	190/836.6	Voice	0.101	-2.40	1.050	0.106	Yes
Right Tilt 15 °	190/836.6	Voice	0.075	3.61	1.050	0.079	/
Left Cheek	190/836.6	Voice	0.100	1.97	1.050	0.105	/
Left Tilt 15 °	190/836.6	Voice	0.073	2.72	1.050	0.077	/
Body-worn(10mm)	Channel /Frequency	Mode	SAR Value (W/kg)1-g	Power drift(%)	Scaled Factor	Scaled SAR (W/Kg)1-g	SAR Plot.
Back Upward	190/836.6	GPRS 4Tx	0.334	3.18	1.007	0.336	Yes
Face Upward	190/836.6	GPRS 4Tx	0.293	0.56	1.007	0.295	/
Hotspot(10mm)	Channel /Frequency	Mode	SAR Value (W/kg)1-g	Power drift(%)	Scaled Factor	Scaled SAR (W/Kg)1-g	SAR Plot.
Back Upward	190/836.6	GPRS 4Tx	0.334	3.18	1.007	0.336	Yes
Face Upward	190/836.6	GPRS 4Tx	0.293	0.56	1.007	0.295	/
Edge B	190/836.6	GPRS 4Tx	0.328	1.70	1.007	0.330	/
Edge C	190/836.6	GPRS 4Tx	0.095	-4.20	1.007	0.096	/
Edge D	190/836.6	GPRS 4Tx	0.279	-4.18	1.007	0.281	/

Results overview of GSM1900

Test Position of Head	Channel /Frequency	Mode	SAR Value (W/kg)1-g	Power drift(%)	Scaled Factor	Scaled SAR (W/Kg)1-g	SAR Plot.
Left Cheek	661/1880.0	Voice	0.076	3.24	1.033	0.078	/
Left Tilt 15 °	661/1880.0	Voice	0.043	1.07	1.033	0.044	/
Right Cheek	661/1880.0	Voice	0.081	-4.12	1.033	0.084	Yes
Right Tilt 15 °	661/1880.0	Voice	0.047	-4.42	1.033	0.049	/
Body-worn(10mm)	Channel /Frequency	Mode	SAR Value (W/kg)1-g	Power drift(%)	Scaled Factor	Scaled SAR (W/Kg)1-g	SAR Plot.
Back Upward	661/1880.0	GPRS 4Tx	0.559	-0.29	1.042	0.583	Yes
Face Upward	661/1880.0	GPRS 4Tx	0.390	-4.03	1.042	0.407	/
Hotspot(10mm)	Channel /Frequency	Mode	SAR Value (W/kg)1-g	Power drift(%)	Scaled Factor	Scaled SAR (W/Kg)1-g	SAR Plot.
Back Upward	661/1880.0	GPRS 4Tx	0.559	-0.29	1.042	0.583	/
Face Upward	661/1880.0	GPRS 4Tx	0.390	-4.03	1.042	0.407	/
Edge B	661/1880.0	GPRS 4Tx	0.372	-1.52	1.042	0.388	/
Edge C	512/1850.2	GPRS 4Tx	0.901	-2.67	1.094	0.986	/
Edge C	661/1880.0	GPRS 4Tx	0.953	0.37	1.042	0.993	Yes
Edge C	810/1909.8	GPRS 4Tx	0.924	-1.12	1.064	0.983	/
Edge C (Repeated)	512/1850.2	GPRS 4Tx	0.787	-3.37	1.094	0.861	/
	661/1880.0	GPRS 4Tx	0.830	-4.61	1.042	0.865	/
	810/1909.8	GPRS 4Tx	0.806	-2.42	1.064	0.858	/
Edge D	661/1880.0	GPRS 4Tx	0.321	2.91	1.042	0.335	/

**Results overview of WCDMA850**

Test Position of Head	Channel /Frequency	Mode	SAR Value (W/kg)1-g	Power drift(%)	Scaled Factor	Scaled SAR (W/Kg)1-g	SAR Plot.
Right Cheek	4183/836.6	RMC	0.042	-0.04	1.026	0.043	/
Right Tilt 15 °	4183/836.6	RMC	0.029	1.11	1.026	0.030	/
Left Cheek	4183/836.6	RMC	0.045	-2.17	1.026	0.046	Yes
Left Tilt 15 °	4183/836.6	RMC	0.030	-4.96	1.026	0.031	/
Body-worn(10mm)	Channel /Frequency	Mode	SAR Value (W/kg)1-g	Power drift(%)	Scaled Factor	Scaled SAR (W/Kg)1-g	SAR Plot.
Back Upward	4183/836.6	RMC	0.033	2.34	1.026	0.034	/
Face Upward	4183/836.6	RMC	0.034	-2.41	1.026	0.035	Yes
Hotspot(10mm)	Channel /Frequency	Mode	SAR Value (W/kg)1-g	Power drift(%)	Scaled Factor	Scaled SAR (W/Kg)1-g	SAR Plot.
Back Upward	4183/836.6	RMC	0.033	2.34	1.026	0.034	/
Face Upward	4183/836.6	RMC	0.034	-2.41	1.026	0.035	/
Edge B	4183/836.6	RMC	0.044	-2.73	1.026	0.045	Yes
Edge C	4183/836.6	RMC	0.013	0.81	1.026	0.013	/
Edge D	4183/836.6	RMC	0.026	3.45	1.026	0.027	/

Results overview of WCDMA1700

Test Position of Head	Channel /Frequency	Mode	SAR Value (W/kg)1-g	Power drift(%)	Scaled Factor	Scaled SAR (W/Kg)1-g	SAR Plot.
Left Cheek	1413/1732.6	RMC	0.026	-3.21	1.153	0.030	Yes
Left Tilt 15 °	1413/1732.6	RMC	0.018	-3.20	1.153	0.021	/
Right Cheek	1413/1732.6	RMC	0.022	-1.59	1.153	0.025	/
Right Tilt 15 °	1413/1732.6	RMC	0.016	-3.66	1.153	0.018	/
Body-worn(10mm)	Channel /Frequency	Mode	SAR Value (W/kg)1-g	Power drift(%)	Scaled Factor	Scaled SAR (W/Kg)1-g	SAR Plot.
Back Upward	1413/1732.6	RMC	0.161	-2.83	1.153	0.186	Yes
Face Upward	1413/1732.6	RMC	0.085	1.49	1.153	0.098	/
Hotspot(10mm)	Channel /Frequency	Mode	SAR Value (W/kg)1-g	Power drift(%)	Scaled Factor	Scaled SAR (W/Kg)1-g	SAR Plot.
Back Upward	1413/1732.6	RMC	0.161	-2.83	1.153	0.186	/
Face Upward	1413/1732.6	RMC	0.085	1.49	1.153	0.098	/
Edge B	1413/1732.6	RMC	0.062	-0.90	1.153	0.072	/
Edge C	1413/1732.6	RMC	0.258	-1.08	1.153	0.298	Yes
Edge D	1413/1732.6	RMC	0.043	-1.10	1.153	0.050	/

Results overview of WCDMA1900

Test Position of Head	Channel /Frequency	Mode	SAR Value (W/kg)1-g	Power drift(%)	Scaled Factor	Scaled SAR (W/Kg)1-g	SAR Plot.
Left Cheek	9400/1880.0	RMC	0.046	-3.76	1.059	0.049	/
Left Tilt 15 °	9400/1880.0	RMC	0.023	3.18	1.059	0.024	/
Right Cheek	9400/1880.0	RMC	0.050	-4.69	1.059	0.053	Yes
Right Tilt 15 °	9400/1880.0	RMC	0.031	3.29	1.059	0.033	/
Body-worn(10mm)	Channel /Frequency	Mode	SAR Value (W/kg)1-g	Power drift(%)	Scaled Factor	Scaled SAR (W/Kg)1-g	SAR Plot.
Back Upward	9400/1880.0	RMC	0.112	2.65	1.059	0.119	Yes
Face Upward	9400/1880.0	RMC	0.082	-3.93	1.059	0.087	/
Hotspot(10mm)	Channel /Frequency	Mode	SAR Value (W/kg)1-g	Power drift(%)	Scaled Factor	Scaled SAR (W/Kg)1-g	SAR Plot.
Back Upward	9400/1880.0	RMC	0.112	2.65	1.059	0.119	/
Face Upward	9400/1880.0	RMC	0.082	-3.93	1.059	0.087	/
Edge B	9400/1880.0	RMC	0.049	-2.74	1.059	0.052	/
Edge C	9400/1880.0	RMC	0.177	4.41	1.059	0.187	Yes
Edge D	9400/1880.0	RMC	0.031	1.05	1.059	0.033	/



Results overview of FDD LTE Band 2, QPSK, 20MHz Bandwidth

Test Position of Head	Channel /Frequency	Mode	SAR Value (W/kg)1-g	Power drift(%)	Scaled Factor	Scaled SAR (W/Kg)1-g	SAR Plot.
1RB#0							
Left Cheek	18900/1880	Data	0.039	-2.59	1.081	0.042	/
Left Tilt 15 °	18900/1880	Data	0.018	-3.51	1.081	0.019	/
Right Cheek	18900/1880	Data	0.059	-3.98	1.081	0.064	Yes
Right Tilt 15 °	18900/1880	Data	0.040	4.87	1.081	0.043	/
50%RB#0							
Left Cheek	18900/1880	Data	0.031	4.55	1.062	0.033	/
Left Tilt 15 °	18900/1880	Data	0.013	-2.65	1.062	0.014	/
Right Cheek	18900/1880	Data	0.050	-1.23	1.062	0.053	/
Right Tilt 15 °	18900/1880	Data	0.032	-2.80	1.062	0.034	/
Body-worn(10mm)	Channel /Frequency	Mode	SAR Value (W/kg)1-g	Power drift(%)	Scaled Factor	Scaled SAR (W/Kg)1-g	SAR Plot.
1RB#0							
Back Upward	18900/1880	Data	0.111	-2.51	1.081	0.120	Yes
Face Upward	18900/1880	Data	0.076	-4.71	1.081	0.082	/
50%RB#0							
Back Upward	18900/1880	Data	0.090	2.94	1.062	0.096	/
Face Upward	18900/1880	Data	0.052	-4.73	1.062	0.055	/
Hotspot(10mm)	Channel /Frequency	Mode	SAR Value (W/kg)1-g	Power drift(%)	Scaled Factor	Scaled SAR (W/Kg)1-g	Limit (W/kg)
1RB#50							
Back Upward	18900/1880	Data	0.111	-2.51	1.081	0.120	/
Face Upward	18900/1880	Data	0.076	-4.71	1.081	0.082	/
Edge B	18900/1880	Data	0.048	-1.97	1.081	0.052	/
Edge C	18900/1880	Data	0.188	-2.66	1.081	0.203	Yes
Edge D	18900/1880	Data	0.023	3.83	1.081	0.025	/
50%RB#0							
Back Upward	18900/1880	Data	0.090	2.94	1.062	0.096	/
Face Upward	18900/1880	Data	0.052	-4.73	1.062	0.055	/
Edge B	18900/1880	Data	0.034	1.25	1.062	0.036	/
Edge C	18900/1880	Data	0.152	4.28	1.062	0.161	/
Edge D	18900/1880	Data	0.015	2.39	1.062	0.016	/



Results overview of FDD LTE Band 4, QPSK, 20MHz Bandwidth

Test Position of Head	Channel /Frequency	Mode	SAR Value (W/kg)1-g	Power drift(%)	Scaled Factor	Scaled SAR (W/Kg)1-g	SAR Plot.
1RB#0							
Left Cheek	20175/1732.5	Data	0.045	-3.99	1.033	0.046	Yes
Left Tilt 15 °	20175/1732.5	Data	0.030	2.75	1.033	0.031	/
Right Cheek	20175/1732.5	Data	0.029	-2.27	1.033	0.030	/
Right Tilt 15 °	20175/1732.5	Data	0.018	0.47	1.033	0.019	/
50%RB#0							
Left Cheek	20175/1732.5	Data	0.036	1.13	1.042	0.038	/
Left Tilt 15 °	20175/1732.5	Data	0.023	-4.48	1.042	0.024	/
Right Cheek	20175/1732.5	Data	0.021	0.06	1.042	0.022	/
Right Tilt 15 °	20175/1732.5	Data	0.012	0.73	1.042	0.013	/
Body-worn(10mm)	Channel /Frequency	Mode	SAR Value (W/kg)1-g	Power drift(%)	Scaled Factor	Scaled SAR (W/Kg)1-g	SAR Plot.
1RB#0							
Back Upward	20175/1732.5	Data	0.251	-0.52	1.033	0.259	Yes
Face Upward	20175/1732.5	Data	0.134	-3.23	1.033	0.138	/
50%RB#0							
Back Upward	20175/1732.5	Data	0.205	1.53	1.042	0.214	/
Face Upward	20175/1732.5	Data	0.089	3.95	1.042	0.093	/
Hotspot(10mm)	Channel /Frequency	Mode	SAR Value (W/kg)1-g	Power drift(%)	Scaled Factor	Scaled SAR (W/Kg)1-g	Limit (W/kg)
1RB#0							
Back Upward	20175/1732.5	Data	0.251	-0.52	1.033	0.259	/
Face Upward	20175/1732.5	Data	0.134	-3.23	1.033	0.138	/
Edge B	20175/1732.5	Data	0.034	1.19	1.033	0.035	/
Edge C	20175/1732.5	Data	0.370	-4.30	1.033	0.382	Yes
Edge D	20175/1732.5	Data	0.033	0.26	1.033	0.034	/
50%RB#0							
Back Upward	20175/1732.5	Data	0.205	1.53	1.042	0.214	/
Face Upward	20175/1732.5	Data	0.089	3.95	1.042	0.093	/
Edge B	20175/1732.5	Data	0.022	2.33	1.042	0.023	/
Edge C	20175/1732.5	Data	0.323	0.12	1.042	0.337	/
Edge D	20175/1732.5	Data	0.020	-1.99	1.042	0.021	/



Results overview of FDD LTE Band 5, QPSK, 10MHz Bandwidth

Test Position of Head	Channel /Frequency	Mode	SAR Value (W/kg)1-g	Power drift(%)	Scaled Factor	Scaled SAR (W/Kg)1-g	SAR Plot.
1RB#0							
Left Cheek	20525/836.5	Data	0.036	-3.15	1.079	0.039	Yes
Left Tilt 15 °	20525/836.5	Data	0.021	3.92	1.079	0.023	/
Right Cheek	20525/836.5	Data	0.030	2.14	1.079	0.032	/
Right Tilt 15 °	20525/836.5	Data	0.016	1.77	1.079	0.017	/
50%RB#0							
Left Cheek	20525/836.5	Data	0.030	-4.31	1.042	0.031	/
Left Tilt 15 °	20525/836.5	Data	0.014	2.70	1.042	0.015	/
Right Cheek	20525/836.5	Data	0.022	-0.33	1.042	0.023	/
Right Tilt 15 °	20525/836.5	Data	0.010	-0.36	1.042	0.010	/
Body-worn(10mm)	Channel /Frequency	Mode	SAR Value (W/kg)1-g	Power drift(%)	Scaled Factor	Scaled SAR (W/Kg)1-g	SAR Plot.
1RB#0							
Face Upward	20525/836.5	Data	0.023	-0.87	1.079	0.025	/
Back Upward	20525/836.5	Data	0.031	-1.75	1.079	0.033	Yes
50%RB#0							
Face Upward	20525/836.5	Data	0.015	4.82	1.042	0.016	/
Back Upward	20525/836.5	Data	0.020	-3.70	1.042	0.021	/
Hotspot(10mm)	Channel /Frequency	Mode	SAR Value (W/kg)1-g	Power drift(%)	Scaled Factor	Scaled SAR (W/Kg)1-g	Limit (W/kg)
1RB#0							
Face Upward	20525/836.5	Data	0.023	-0.87	1.079	0.025	/
Back Upward	20525/836.5	Data	0.031	-1.75	1.079	0.033	Yes
Edge B	20525/836.5	Data	0.028	2.94	1.079	0.030	/
Edge C	20525/836.5	Data	0.010	-3.44	1.079	0.011	/
Edge D	20525/836.5	Data	0.024	-1.11	1.079	0.026	/
50%RB#0							
Face Upward	20525/836.5	Data	0.015	4.82	1.042	0.016	/
Back Upward	20525/836.5	Data	0.020	-3.70	1.042	0.021	/
Edge B	20525/836.5	Data	0.017	-1.31	1.042	0.018	/
Edge C	20525/836.5	Data	0.007	0.86	1.042	0.007	/
Edge D	20525/836.5	Data	0.013	-1.05	1.042	0.014	/



Results overview of FDD LTE Band 7, QPSK, 20MHz Bandwidth

Test Position of Head	Channel /Frequency	Mode	SAR Value (W/kg)1-g	Power drift(%)	Scaled Factor	Scaled SAR (W/Kg)1-g	SAR Plot.
1RB#0							
Left Cheek	21100/2535	Data	0.012	-1.50	1.094	0.013	Yes
Left Tilt 15 °	21100/2535	Data	0.010	2.61	1.094	0.011	/
Right Cheek	21100/2535	Data	0.011	-3.08	1.094	0.012	/
Right Tilt 15 °	21100/2535	Data	0.009	-4.19	1.094	0.010	/
50%RB#0							
Left Cheek	21100/2535	Data	0.011	1.73	1.089	0.012	/
Left Tilt 15 °	21100/2535	Data	0.010	-1.05	1.089	0.011	/
Right Cheek	21100/2535	Data	0.010	0.50	1.089	0.011	/
Right Tilt 15 °	21100/2535	Data	0.007	-4.20	1.089	0.008	/
Body-worn(10mm)	Channel /Frequency	Mode	SAR Value (W/kg)1-g	Power drift(%)	Scaled Factor	Scaled SAR (W/Kg)1-g	SAR Plot.
1RB#0							
Face Upward	21100/2535	Data	0.068	1.87	1.094	0.074	/
Back Upward	21100/2535	Data	0.215	-0.11	1.094	0.235	Yes
50%RB#0							
Face Upward	21100/2535	Data	0.051	4.33	1.089	0.056	/
Back Upward	21100/2535	Data	0.189	-4.63	1.089	0.206	/
Hotspot(10mm)	Channel /Frequency	Mode	SAR Value (W/kg)1-g	Power drift(%)	Scaled Factor	Scaled SAR (W/Kg)1-g	Limit (W/kg)
1RB#0							
Face Upward	21100/2535	Data	0.068	1.87	1.094	0.074	/
Back Upward	21100/2535	Data	0.215	-0.11	1.094	0.235	/
Edge B	21100/2535	Data	0.020	-2.84	1.094	0.022	/
Edge C	21100/2535	Data	0.216	-0.67	1.094	0.236	Yes
Edge D	21100/2535	Data	0.028	4.43	1.094	0.031	/
50%RB#0							
Face Upward	21100/2535	Data	0.051	4.33	1.089	0.056	/
Back Upward	21100/2535	Data	0.189	-4.63	1.089	0.206	/
Edge B	21100/2535	Data	0.012	4.23	1.089	0.013	/
Edge C	21100/2535	Data	0.194	-2.22	1.089	0.211	/
Edge D	21100/2535	Data	0.020	2.25	1.089	0.022	/



Results overview of FDD LTE Band 12, QPSK, 10MHz Bandwidth

Test Position of Head	Channel /Frequency	Mode	SAR Value (W/kg)1-g	Power drift(%)	Scaled Factor	Scaled SAR (W/Kg)1-g	SAR Plot.
1RB#0							
Left Cheek	23095/707.5	Data	0.045	-2.98	1.057	0.048	Yes
Left Tilt 15 °	23095/707.5	Data	0.030	-1.21	1.057	0.032	/
Right Cheek	23095/707.5	Data	0.038	-3.54	1.057	0.040	/
Right Tilt 15 °	23095/707.5	Data	0.023	0.63	1.057	0.024	/
50%RB#0							
Left Cheek	23095/707.5	Data	0.038	-1.43	1.047	0.040	/
Left Tilt 15 °	23095/707.5	Data	0.023	3.95	1.047	0.024	/
Right Cheek	23095/707.5	Data	0.028	-1.52	1.047	0.029	/
Right Tilt 15 °	23095/707.5	Data	0.015	-2.67	1.047	0.016	/
Body-worn(10mm)	Channel /Frequency	Mode	SAR Value (W/kg)1-g	Power drift(%)	Scaled Factor	Scaled SAR (W/Kg)1-g	SAR Plot.
1RB#0							
Back Upward	23095/707.5	Data	0.048	-1.05	1.057	0.051	Yes
Face Upward	23095/707.5	Data	0.045	-3.41	1.057	0.048	/
50%RB#0							
Back Upward	23095/707.5	Data	0.033	2.12	1.047	0.035	/
Face Upward	23095/707.5	Data	0.030	2.68	1.047	0.031	/
Hotspot(10mm)	Channel /Frequency	Mode	SAR Value (W/kg)1-g	Power drift(%)	Scaled Factor	Scaled SAR (W/Kg)1-g	Limit (W/kg)
1RB#0							
Back Upward	23095/707.5	Data	0.048	-1.05	1.057	0.051	Yes
Face Upward	23095/707.5	Data	0.045	-3.41	1.057	0.048	/
Edge B	23095/707.5	Data	0.032	3.42	1.057	0.034	/
Edge C	23095/707.5	Data	0.011	4.78	1.057	0.012	/
Edge D	23095/707.5	Data	0.036	3.64	1.057	0.038	/
50%RB#0							
Back Upward	23095/707.5	Data	0.033	2.12	1.047	0.035	/
Face Upward	23095/707.5	Data	0.030	2.68	1.047	0.031	/
Edge B	23095/707.5	Data	0.019	-2.25	1.047	0.020	/
Edge C	23095/707.5	Data	0.007	4.36	1.047	0.007	/
Edge D	23095/707.5	Data	0.022	-2.04	1.047	0.023	/



Results overview of FDD LTE Band 17, QPSK, 10MHz Bandwidth

Test Position of Head	Channel /Frequency	Mode	SAR Value (W/kg)1-g	Power drift(%)	Scaled Factor	Scaled SAR (W/Kg)1-g	SAR Plot.
1RB#0							
Left Cheek	23790/710	Data	0.037	-4.27	1.045	0.039	Yes
Left Tilt 15 °	23790/710	Data	0.024	-4.81	1.045	0.025	/
Right Cheek	23790/710	Data	0.036	3.68	1.045	0.038	/
Right Tilt 15 °	23790/710	Data	0.022	2.26	1.045	0.023	/
50%RB#0							
Left Cheek	23790/710	Data	0.030	-1.31	1.089	0.033	/
Left Tilt 15 °	23790/710	Data	0.016	2.79	1.089	0.017	/
Right Cheek	23790/710	Data	0.027	-3.88	1.089	0.029	/
Right Tilt 15 °	23790/710	Data	0.013	0.59	1.089	0.014	/
Body-worn(10mm)	Channel /Frequency	Mode	SAR Value (W/kg)1-g	Power drift(%)	Scaled Factor	Scaled SAR (W/Kg)1-g	SAR Plot.
1RB#0							
Back Upward	23790/710	Data	0.041	-1.93	1.045	0.043	Yes
Face Upward	23790/710	Data	0.033	-0.34	1.045	0.034	/
50%RB#0							
Back Upward	23790/710	Data	0.032	4.86	1.089	0.035	/
Face Upward	23790/710	Data	0.021	-1.39	1.089	0.023	/
Body-worn(10mm)	Channel /Frequency	Mode	SAR Value (W/kg)1-g	Power drift(%)	Scaled Factor	Scaled SAR (W/Kg)1-g	Limit (W/kg)
1RB#0							
Back Upward	23790/710	Data	0.041	-1.93	1.045	0.043	Yes
Face Upward	23790/710	Data	0.033	-0.34	1.045	0.034	/
Edge B	23790/710	Data	0.023	-1.55	1.045	0.024	/
Edge C	23790/710	Data	0.008	-1.69	1.045	0.008	/
Edge D	23790/710	Data	0.030	2.16	1.045	0.031	/
50%RB#0							
Back Upward	23790/710	Data	0.032	4.86	1.089	0.035	/
Face Upward	23790/710	Data	0.021	-1.39	1.089	0.023	/
Edge B	23790/710	Data	0.012	0.26	1.089	0.013	/
Edge C	23790/710	Data	0.006	4.65	1.089	0.007	/
Edge D	23790/710	Data	0.017	-3.44	1.089	0.019	/



Results overview of TDD LTE Band 41, QPSK, 20MHz Bandwidth

Test Position of Head	Channel /Frequency	Mode	SAR Value (W/kg)1-g	Power drift(%)	Scaled Factor	Scaled SAR (W/Kg)1-g	SAR Plot.
1RB#0							
Left Cheek	40620/2593	Data	0.019	+2.70	1.012	0.019	Yes
Left Tilt 15 °	40620/2593	Data	0.013	-1.40	1.012	0.013	/
Right Cheek	40620/2593	Data	0.016	-3.48	1.012	0.016	/
Right Tilt 15 °	40620/2593	Data	0.012	4.81	1.012	0.012	/
50%RB#0							
Left Cheek	40620/2593	Data	0.015	4.10	1.052	0.016	/
Left Tilt 15 °	40620/2593	Data	0.010	-4.53	1.052	0.011	/
Right Cheek	40620/2593	Data	0.013	-1.24	1.052	0.014	/
Right Tilt 15 °	40620/2593	Data	0.008	0.25	1.052	0.008	/
Body-worn(10mm)	Channel /Frequency	Mode	SAR Value (W/kg)1-g	Power drift(%)	Scaled Factor	Scaled SAR (W/Kg)1-g	SAR Plot.
1RB#0							
Face Upward	40620/2593	Data	0.032	-4.95	1.012	0.032	/
Back Upward	40620/2593	Data	0.066	-1.31	1.012	0.067	Yes
50%RB#0							
Face Upward	40620/2593	Data	0.023	0.89	1.052	0.024	/
Back Upward	40620/2593	Data	0.051	-1.40	1.052	0.054	/
Hotspot(10mm)	Channel /Frequency	Mode	SAR Value (W/kg)1-g	Power drift(%)	Scaled Factor	Scaled SAR (W/Kg)1-g	Limit (W/kg)
1RB#0							
Face Upward	40620/2593	Data	0.032	-4.95	1.012	0.032	/
Back Upward	40620/2593	Data	0.066	-1.31	1.012	0.067	/
Edge B	40620/2593	Data	0.016	-0.13	1.012	0.016	/
Edge C	40620/2593	Data	0.075	-2.02	1.012	0.076	Yes
Edge D	40620/2593	Data	0.024	-3.91	1.012	0.024	/
50%RB#0							
Face Upward	40620/2593	Data	0.023	0.89	1.052	0.024	/
Back Upward	40620/2593	Data	0.051	-1.40	1.052	0.054	/
Edge B	40620/2593	Data	0.011	1.19	1.052	0.012	/
Edge C	40620/2593	Data	0.058	-4.10	1.052	0.061	/
Edge D	40620/2593	Data	0.015	2.74	1.052	0.016	/



Results overview of FDD LTE Band 66, QPSK, 20MHz Bandwidth

Test Position of Head	Channel /Frequency	Mode	SAR Value (W/kg)1-g	Power drift(%)	Scaled Factor	Scaled SAR (W/Kg)1-g	SAR Plot.
1RB#0							
Left Cheek	132322/1745	Data	0.060	-3.34	1.033	0.062	Yes
Left Tilt 15 °	132322/1745	Data	0.037	1.98	1.033	0.038	/
Right Cheek	132322/1745	Data	0.046	1.78	1.033	0.048	/
Right Tilt 15 °	132322/1745	Data	0.030	-1.71	1.033	0.031	/
50%RB#0							
Left Cheek	132322/1745	Data	0.044	-2.09	1.033	0.045	/
Left Tilt 15 °	132322/1745	Data	0.025	-0.79	1.033	0.026	/
Right Cheek	132322/1745	Data	0.037	3.48	1.033	0.038	/
Right Tilt 15 °	132322/1745	Data	0.020	1.73	1.033	0.021	/
Body-worn(10mm)	Channel /Frequency	Mode	SAR Value (W/kg)1-g	Power drift(%)	Scaled Factor	Scaled SAR (W/Kg)1-g	SAR Plot.
1RB#0							
Back Upward	132322/1745	Data	0.660	-1.29	1.033	0.682	Yes
Face Upward	132322/1745	Data	0.382	0.32	1.033	0.395	/
50%RB#0							
Back Upward	132322/1745	Data	0.594	-4.68	1.033	0.613	/
Face Upward	132322/1745	Data	0.303	-3.31	1.033	0.313	/
Hotspot(10mm)	Channel /Frequency	Mode	SAR Value (W/kg)1-g	Power drift(%)	Scaled Factor	Scaled SAR (W/Kg)1-g	Limit (W/kg)
1RB#0							
Back Upward	132322/1745	Data	0.660	-1.29	1.033	0.682	Yes
Face Upward	132322/1745	Data	0.382	0.32	1.033	0.395	/
Edge B	132322/1745	Data	0.121	-2.91	1.033	0.125	/
Edge C	132322/1745	Data	0.646	0.16	1.033	0.667	/
Edge D	132322/1745	Data	0.103	4.47	1.033	0.106	/
50%RB#0							
Back Upward	132322/1745	Data	0.594	-4.68	1.033	0.613	/
Face Upward	132322/1745	Data	0.303	-3.31	1.033	0.313	/
Edge B	132322/1745	Data	0.090	0.36	1.033	0.093	/
Edge C	132322/1745	Data	0.567	-2.21	1.033	0.586	/
Edge D	132322/1745	Data	0.078	2.83	1.033	0.081	/



Results overview of FDD LTE Band 71, QPSK, 20MHz Bandwidth

Test Position of Head	Channel /Frequency	Mode	SAR Value (W/kg)1-g	Power drift(%)	Scaled Factor	Scaled SAR (W/Kg)1-g	SAR Plot.
1RB#0							
Left Cheek	133322/683	Data	0.166	-3.56	1.057	0.175	Yes
Left Tilt 15 °	133322/683	Data	0.137	-1.57	1.057	0.145	/
Right Cheek	133322/683	Data	0.124	0.91	1.057	0.131	/
Right Tilt 15 °	133322/683	Data	0.102	0.29	1.057	0.108	/
50%RB#0							
Left Cheek	133322/683	Data	0.144	-4.13	1.042	0.150	/
Left Tilt 15 °	133322/683	Data	0.121	1.49	1.042	0.126	/
Right Cheek	133322/683	Data	0.117	-1.58	1.042	0.122	/
Right Tilt 15 °	133322/683	Data	0.097	4.13	1.042	0.101	/
Body-worn(10mm)	Channel /Frequency	Mode	SAR Value (W/kg)1-g	Power drift(%)	Scaled Factor	Scaled SAR (W/Kg)1-g	SAR Plot.
1RB#0							
Back Upward	133322/683	Data	0.178	-3.09	1.057	0.188	Yes
Face Upward	133322/683	Data	0.145	-2.85	1.057	0.153	/
50%RB#0							
Back Upward	133322/683	Data	0.136	-0.61	1.042	0.142	/
Face Upward	133322/683	Data	0.109	4.03	1.042	0.114	/
Hotspot(10mm)	Channel /Frequency	Mode	SAR Value (W/kg)1-g	Power drift(%)	Scaled Factor	Scaled SAR (W/Kg)1-g	Limit (W/kg)
1RB#0							
Back Upward	133322/683	Data	0.178	-3.09	1.057	0.188	Yes
Face Upward	133322/683	Data	0.145	-2.85	1.057	0.153	/
Edge B	133322/683	Data	0.072	-2.85	1.057	0.076	/
Edge C	133322/683	Data	0.126	-3.59	1.057	0.133	/
Edge D	133322/683	Data	0.065	-2.16	1.057	0.069	/
50%RB#0							
Back Upward	133322/683	Data	0.152	2.70	1.042	0.158	/
Face Upward	133322/683	Data	0.118	0.34	1.042	0.123	/
Edge B	133322/683	Data	0.058	1.68	1.042	0.060	/
Edge C	133322/683	Data	0.114	3.85	1.042	0.119	/
Edge D	133322/683	Data	0.041	-2.70	1.042	0.043	/

Results overview of WIFI2.4G 802.11b

Test Position of Head	Channel /Frequency	Mode	SAR Value (W/kg)1-g	Power drift(%)	Scaled Factor	Scaled SAR (W/Kg)1-g	SAR Plot.
Left Cheek	6/2437	DSSS	0.071	4.90	1.135	0.081	/
Left Tilt 15 °	6/2437	DSSS	0.090	-4.42	1.135	0.102	/
Right Cheek	6/2437	DSSS	0.076	-0.80	1.135	0.086	/
Right Tilt 15 °	6/2437	DSSS	0.092	-1.71	1.135	0.104	Yes
Body-worn(10mm)	Channel /Frequency	Mode	SAR Value (W/kg)1-g	Power drift(%)	Scaled Factor	Scaled SAR (W/Kg)1-g	SAR Plot.
Face Upward	6/2437	DSSS	0.061	-4.27	1.135	0.069	/
Back Upward	6/2437	DSSS	0.088	-1.77	1.135	0.100	Yes
Hotspot(10mm)	Channel /Frequency	Mode	SAR Value (W/kg)1-g	Power drift(%)	Scaled Factor	Scaled SAR (W/Kg)1-g	SAR Plot.
Face Upward	6/2437	DSSS	0.061	-4.27	1.135	0.069	/
Back Upward	6/2437	DSSS	0.088	-1.77	1.135	0.100	Yes
Edge A	6/2437	DSSS	0.075	-1.65	1.135	0.085	/
Edge B	6/2437	DSSS	0.050	-2.56	1.135	0.057	/

Results overview of BT

Test Position of Head	Channel /Frequency	Mode	SAR Value (W/kg)1-g	Power drift(%)	Scaled Factor	Scaled SAR (W/Kg)1-g	SAR Plot.
Left Cheek	39/2441	DH5	0.040	-0.89	1.040	0.042	/
Left Tilt 15 °	39/2441	DH5	0.048	-4.28	1.040	0.050	Yes
Right Cheek	39/2441	DH5	0.031	4.11	1.040	0.032	/
Right Tilt 15 °	39/2441	DH5	0.036	-0.09	1.040	0.037	/
Body-worn(10mm)	Channel /Frequency	Mode	SAR Value (W/kg)1-g	Power drift(%)	Scaled Factor	Scaled SAR (W/Kg)1-g	SAR Plot.
Back Upward	39/2441	DH5	0.018	-2.59	1.040	0.019	Yes
Face Upward	39/2441	DH5	0.012	-1.76	1.040	0.012	/

Results overview of WIFI 5G 802.11n 20MHz-5240

Test Position of Head	Channel /Frequency	Mode	SAR Value (W/kg)1-g	Power drift(%)	Scaled Factor	Scaled SAR (W/Kg)1-g	SAR Plot.
Left Cheek	48/5240	OFDM	0.066	-3.28	1.016	0.067	/
Left Tilt 15 °	48/5240	OFDM	0.078	4.57	1.016	0.079	/
Right Cheek	48/5240	OFDM	0.070	3.98	1.016	0.071	/
Right Tilt 15 °	48/5240	OFDM	0.082	1.20	1.016	0.083	/
Body-worn(10mm)	Channel /Frequency	Mode	SAR Value (W/kg)1-g	Power drift(%)	Scaled Factor	Scaled SAR (W/Kg)1-g	SAR Plot.
Back Upward	48/5240	OFDM	0.068	-3.53	1.016	0.069	/
Face Upward	48/5240	OFDM	0.050	3.08	1.016	0.051	/

Results overview of WIFI 5G 802.11n 20MHz-5260

Test Position of Head	Channel /Frequency	Mode	SAR Value (W/kg)1-g	Power drift(%)	Scaled Factor	Scaled SAR (W/Kg)1-g	SAR Plot.
Left Cheek	52/5260	OFDM	0.057	-0.94	1.012	0.058	/
Left Tilt 15 °	52/5260	OFDM	0.066	-1.29	1.012	0.067	/
Right Cheek	52/5260	OFDM	0.060	3.01	1.012	0.061	/
Right Tilt 15 °	52/5260	OFDM	0.071	0.94	1.012	0.072	/
Body-worn(10mm)	Channel /Frequency	Mode	SAR Value (W/kg)1-g	Power drift(%)	Scaled Factor	Scaled SAR (W/Kg)1-g	SAR Plot.
Back Upward	52/5260	OFDM	0.055	2.95	1.012	0.056	/
Face Upward	52/5260	OFDM	0.037	0.99	1.012	0.037	/

Results overview of WIFI 5G 802.11ac 20MHz-5700

Test Position of Head	Channel /Frequency	Mode	SAR Value (W/kg)1-g	Power drift(%)	Scaled Factor	Scaled SAR (W/Kg)1-g	SAR Plot.
Left Cheek	140/5700	OFDM	0.089	1.76	1.014	0.090	/
Left Tilt 15 °	140/5700	OFDM	0.101	-4.18	1.014	0.102	/
Right Cheek	140/5700	OFDM	0.093	-4.13	1.014	0.094	/
Right Tilt 15 °	140/5700	OFDM	0.104	-3.62	1.014	0.105	Yes
Body-worn(10mm)	Channel /Frequency	Mode	SAR Value (W/kg)1-g	Power drift(%)	Scaled Factor	Scaled SAR (W/Kg)1-g	SAR Plot.
Back Upward	120/5600	OFDM	0.094	-1.92	1.014	0.095	Yes
Face Upward	120/5600	OFDM	0.071	-2.37	1.014	0.072	/

Results overview of WIFI 5G 802.11a 20MHz-5785

Test Position of Head	Channel /Frequency	Mode	SAR Value (W/kg)1-g	Power drift(%)	Scaled Factor	Scaled SAR (W/Kg)1-g	SAR Plot.
Left Cheek	157/5785	OFDM	0.040	3.78	1.007	0.040	/
Left Tilt 15 °	157/5785	OFDM	0.047	-3.95	1.007	0.047	/
Right Cheek	157/5785	OFDM	0.046	0.98	1.007	0.046	/
Right Tilt 15 °	157/5785	OFDM	0.052	-0.51	1.007	0.052	/
Body-worn(10mm)	Channel /Frequency	Mode	SAR Value (W/kg)1-g	Power drift(%)	Scaled Factor	Scaled SAR (W/Kg)1-g	SAR Plot.
Back Upward	157/5785	OFDM	0.048	0.04	1.007	0.048	/
Face Upward	157/5785	OFDM	0.023	4.39	1.007	0.023	/

Note:

Per KDB941225 D06 v02r01, When the antenna-to-edge distance is greater than 2.5cm, such position does not need to be tested. As the manufacture requirement the separation distance use 5mm for Hotspot mode.

Per KDB Publication 941225 D01v03r01. RMC 12.2kbps was as primary mode SAR, when the primary mode SAR less than 1.2W/kg, secondary SAR (HSPA) was not requires.

When the 1-g SAR for the mid-band channel or the channel with the highest output power satisfy the following conditions, testing of the other channels in the band is not required. (Per KDB 447498 D01 General RF Exposure Guidance v06)

- ≤ 0.8 W/kg, when the transmission band is ≤ 100 MHz
- ≤ 0.6 W/kg, when the transmission band is between 100 MHz and 200 MHz
- ≤ 0.4 W/kg, when the transmission band is ≥ 200 MHz



10. Simultaneous Transmissions Analysis

Localized Specific Absorption Rate (SAR) of this portable wireless device has been measured in all cases requested by the relevant standards cited in Clause 6 of this report. Maximum localized SAR is **below** exposure limits specified in the relevant standards.

Simultaneous SAR

No.	Transmitter Combinations	Scenario Supported or not	Supported for Mobile Hotspot or not
1	GSM + BT	Yes	No
2	GSM + WIFI 2.4G	Yes	Yes
3	WCDMA +BT	Yes	No
4	WCDMA +WIFI 2.4G	Yes	Yes
5	LTE+BT	Yes	No
6	LTE+WIFI 2.4G	Yes	Yes
7	WIFI+BT	No	No

Simultaneous Tx Combination of GSM/WCDMA/LTE and BT/WIFI (Head)

Test Position/Freq.	Right Cheek	Right Tilt 15 °	Left Cheek	Left Tilt 15 °	
Head MAX 1-g SAR(W/Kg)	GSM850	0.106	0.079	0.105	0.077
	GSM1900	0.084	0.049	0.078	0.044
	WCDMA 850	0.043	0.030	0.046	0.031
	WCDMA 1700	0.025	0.018	0.030	0.021
	WCDMA 1900	0.053	0.033	0.049	0.024
	LTE Band2	0.064	0.043	0.042	0.019
	LTE Band4	0.030	0.019	0.046	0.031
	LTE Band5	0.032	0.017	0.039	0.023
	LTE Band7	0.012	0.010	0.013	0.011
	LTE Band12	0.040	0.024	0.048	0.032
	LTE Band17	0.038	0.023	0.039	0.025
	LTE Band41	0.016	0.012	0.019	0.013
	LTE Band66	0.048	0.031	0.062	0.038
	LTE Band71	0.131	0.108	0.175	0.145
	WIFI 2.4G	0.086	0.104	0.081	0.102
	WIFI 5G	0.094	0.105	0.090	0.102
BT	0.032	0.037	0.042	0.050	
WIFI2.4G Simultaneous \sum 1-g SAR(W/Kg)	0.217	0.212	0.256	0.247	
WIFI5G Simultaneous \sum 1-g SAR(W/Kg)	0.225	0.213	0.265	0.247	
BT Simultaneous \sum 1-g SAR(W/Kg)	0.163	0.145	0.217	0.195	



Simultaneous Tx Combination of GSM/WCDMA/LTE and BT/WIFI (Body).

Test Position/Freq.	BACK	FACE	Edge A	Edge B	Edge C	Edge D
Body MAX 1-g SAR(W/Kg) 10mm distance	GSM850	0.336	0.295	/	/	/
	GSM1900	0.583	0.407	/	/	/
	WCDMA 850	0.034	0.035	/	/	/
	WCDMA 1700	0.186	0.098	/	/	/
	WCDMA 1900	0.119	0.087	/	/	/
	LTE Band2	0.120	0.082	/	/	/
	LTE Band4	0.259	0.138	/	/	/
	LTE Band5	0.033	0.025	/	/	/
	LTE Band7	0.235	0.074	/	/	/
	LTE Band12	0.051	0.048	/	/	/
	LTE Band17	0.043	0.034	/	/	/
	LTE Band41	0.067	0.032	/	/	/
	LTE Band66	0.682	0.395	/	/	/
	LTE Band71	0.188	0.153	/	/	/
	WIFI 2.4G	0.100	0.069	/	/	/
	WIFI 5G	0.095	0.072	/	/	/
	BT	0.019	0.012	/	/	/
WIFI2.4G Simultaneous \sum 1-g SAR(W/Kg)	0.782	0.476	/	/	/	
WIFI5G Simultaneous \sum 1-g SAR(W/Kg)	0.777	0.479	/	/	/	
BT Simultaneous \sum 1-gSAR(W/Kg)	0.701	0.419	/	/	/	



Simultaneous Tx Combination of GSM/WCDMA/LTE and WIFI (Body).

Test Position/Freq.		BACK	FACE	Edge A	Edge B	Edge C	Edge D
Hotspot MAX 1-g SAR(W/Kg) 10mm distance	GSM850	0.336	0.295	/	0.330	0.096	0.281
	GSM1900	0.583	0.407	/	0.388	0.993	0.335
	WCDMA 850	0.034	0.035	/	0.045	0.013	0.027
	WCDMA 1700	0.186	0.098	/	0.072	0.298	0.050
	WCDMA 1900	0.119	0.087	/	0.052	0.187	0.033
	LTE Band2	0.120	0.082	/	0.052	0.203	0.025
	LTE Band4	0.259	0.138	/	0.035	0.382	0.034
	LTE Band5	0.033	0.025	/	0.030	0.011	0.026
	LTE Band7	0.235	0.074	/	0.022	0.236	0.031
	LTE Band12	0.051	0.048	/	0.034	0.012	0.038
	LTE Band17	0.043	0.034	/	0.024	0.008	0.031
	LTE Band41	0.067	0.032	/	0.016	0.076	0.024
	LTE Band66	0.682	0.395	/	0.125	0.667	0.106
	LTE Band71	0.188	0.153		0.076	0.133	0.069
WIFI 2.4G	0.100	0.069	0.085	0.057	/	/	
WIFI2.4G Simultaneous \sum 1-g SAR(W/Kg)		0.782	0.476	/	0.445	/	/

SAR to Peak Location Separation Ratio (SPLSR)

As the Sum of the SAR is not greater than 1.6 W/kg SPLSR assessment is not required

11. Measurement Uncertainty

No.	Uncertainty Component	Type	Uncertainty Value (%)	Probability Distribution	k	ci	Standard Uncertainty (%) $u_i(\%)$	Degree of freedom ν_{eff} or ν_i
Measurement System								
1	– Probe Calibration	B	5.8	N	1	1	5.8	∞
2	– Axial isotropy	B	3.5	R	$\sqrt{3}$	0.5	1.43	∞
3	– Hemispherical Isotropy	B	5.9	R	$\sqrt{3}$	0.5	2.41	∞
4	– Boundary Effect	B	1	R	$\sqrt{3}$	1	0.58	∞
5	– Linearity	B	4.7	R	$\sqrt{3}$	1	2.71	∞
6	– System Detection Limits	B	1.0	R	$\sqrt{3}$	1	0.58	∞
7	Modulation response	B	3	N	1	1	3.00	
8	– Readout Electronics	B	0.5	N	1	1	0.50	∞
9	– Response Time	B	1.4	R	$\sqrt{3}$	1	0.81	∞
10	– Integration Time	B	3.0	R	$\sqrt{3}$	1	1.73	∞
11	– RF Ambient Conditions	B	3.0	R	$\sqrt{3}$	1	1.73	∞
12	– Probe Position Mechanical tolerance	B	1.4	R	$\sqrt{3}$	1	0.81	∞
13	– Probe Position with respect to Phantom Shell	B	1.4	R	$\sqrt{3}$	1	0.81	∞
14	– Extrapolation, Interpolation and Integration Algorithms for Max. SAR evaluation	B	2.3	R	$\sqrt{3}$	1	1.33	∞
Uncertainties of the DUT								



15	- Position of the DUT	A	2.6	N	$\sqrt{3}$	1	2.6	5
16	- Holder of the DUT	A	3	N	$\sqrt{3}$	1	3.0	5
17	- Output Power Variation -SAR drift measurement	B	5.0	R	$\sqrt{3}$	1	2.89	∞
Phantom and Tissue Parameters								
18	- Phantom Uncertainty(shape and thickness tolerances)	B	4	R	$\sqrt{3}$	1	2.31	∞
19	Uncertainty in SAR correction for deviation(in permittivity and conductivity)	B	2	N	1	1	2.00	
20	- Liquid Conductivity Target -tolerance	B	2.5	R	$\sqrt{3}$	0.6	1.95	∞
21	- Liquid Conductivity -measurement Uncertainty)	B	4	N	$\sqrt{3}$	1	0.92	9
22	- Liquid Permittivity Target tolerance	B	2.5	R	$\sqrt{3}$	0.6	1.95	∞
23	- Liquid Permittivity -measurement uncertainty	B	5	N	$\sqrt{3}$	1	1.15	∞
Combined Standard Uncertainty				RSS			10.63	
Expanded uncertainty (Confidence interval of 95 %)				K=2			21.26	

System Check Uncertainty

No.	Uncertainty Component	Type	Uncertainty Value (%)	Probability Distribution	k	ci	Standard Uncertainty (%) $u_i(\%)$	Degree of freedom V_{eff} or v_i
Measurement System								
1	- Probe Calibration	B	5.8	N	1	1	5.8	∞
2	- Axial isotropy	B	3.5	R	$\sqrt{3}$	0.5	1.43	∞



3	– Hemispherical Isotropy	B	5.9	R	$\sqrt{3}$	0.5	2.41	∞
4	– Boundary Effect	B	1	R	$\sqrt{3}$	1	0.58	∞
5	– Linearity	B	4.7	R	$\sqrt{3}$	1	2.71	∞
6	– System Detection Limits	B	1	R	$\sqrt{3}$	1	0.58	∞
7	Modulation response	B	0	N	1	1	0.00	
8	– Readout Electronics	B	0.5	N	1	1	0.50	∞
9	– Response Time	B	0.00	R	$\sqrt{3}$	1	0.00	∞
10	– Integration Time	B	1.4	R	$\sqrt{3}$	1	0.81	∞
11	– RF Ambient Conditions	B	3.0	R	$\sqrt{3}$	1	1.73	∞
12	– Probe Position Mechanical tolerance	B	1.4	R	$\sqrt{3}$	1	0.81	∞
13	– Probe Position with respect to Phantom Shell	B	1.4	R	$\sqrt{3}$	1	0.81	∞
14	– Extrapolation, Interpolation and Integration Algorithms for Max. SAR evaluation	B	2.3	R	$\sqrt{3}$	1	1.33	∞
Uncertainties of the DUT								
15	Deviation of experimental source from numerical source	A	4	N	1	1	4.00	5
16	Input Power and SAR drift measurement	A	5	R	$\sqrt{3}$	1	2.89	5
17	Dipole Axis to Liquid Distance	B	2	R	$\sqrt{3}$	1	1.2	∞
Phantom and Tissue Parameters								
18	– Phantom Uncertainty(shape	B	4	R	$\sqrt{3}$	1	2.31	∞



	and thickness tolerances)							
19	Uncertainty in SAR correction for deviation(in permittivity and conductivity)	B	2	N	1	1	2.00	
20	– Liquid Conductivity Target –tolerance	B	2.5	R	$\sqrt{3}$	0.6	1.95	∞
21	– Liquid Conductivity –measurement Uncertainty)	B	4	N	$\sqrt{3}$	1	0.92	9
22	– Liquid Permittivity Target tolerance	B	2.5	R	$\sqrt{3}$	0.6	1.95	∞
23	– Liquid Permittivity –measurement uncertainty	B	5	N	$\sqrt{3}$	1	1.15	∞
Combined Standard Uncertainty				RSS			10.15	
Expanded uncertainty (Confidence interval of 95 %)				K=2			20.29	



12. Equipment List

This table is a complete overview of the SAR measurement equipment. Devices used during the test described are marked .

	EQUIPMENT	Model	Serial number	Calibration Date	Due Date
<input checked="" type="checkbox"/>	SAR Probe	SSE2	SN36/20 EPG0348	2020/12/14	2021/12/13
<input checked="" type="checkbox"/>	Dipole	SID750	SN23/15 DIP0G750-378	2020/06/25	2023/06/24
<input checked="" type="checkbox"/>	Dipole	SID835	SN09/13DIP0G835-217	2020/06/25	2023/06/24
<input checked="" type="checkbox"/>	Dipole	SID900	SN09/13DIP0G900-215	2020/06/25	2023/06/24
<input checked="" type="checkbox"/>	Dipole	SID1800	SN09/13DIP1G800-216	2020/06/25	2023/06/24
<input checked="" type="checkbox"/>	Dipole	SID2000	SN09/13DIP2G000-219	2020/06/25	2023/06/24
<input checked="" type="checkbox"/>	Dipole	SID2450	SN_09/13_DIP2G450-220	2020/06/25	2023/06/24
<input checked="" type="checkbox"/>	Dipole	SID2600	SN 32/14_DIP2G600-338	2020/06/25	2023/06/24
<input checked="" type="checkbox"/>	Dipole	SWG5500	SN15/15 WGA39	2020/06/25	2023/06/24
<input checked="" type="checkbox"/>	Multimeter	Keithley-2000	4014020	2021/04/02	2022/04/01
<input checked="" type="checkbox"/>	System Simulator(R&S)	CMW500	130805	2021/03/19	2022/03/18
<input checked="" type="checkbox"/>	KEYSIGHT	E7515A	MY56040357	2021/04/02	2022/04/01
<input checked="" type="checkbox"/>	Vector Network Analyzer(R&S)	ZVB8	A0802530	2021/04/02	2022/04/01
<input checked="" type="checkbox"/>	PC 3.5 Fixed Match Calibration Kit	ZV-Z32	100571	2020/11/26	2021/11/25
<input checked="" type="checkbox"/>	Dielectric Probe Kit	SCLMP	SN 09/13 OCPG51	2020/11/26	2021/11/25
<input checked="" type="checkbox"/>	Signal Generator	SMU200A	A140801888	2021/03/12	2022/03/11
<input checked="" type="checkbox"/>	Amplifier	Nucletudes	143060	2021/03/12	2022/03/11
<input checked="" type="checkbox"/>	Directional Coupler	DC6180A	305827	2021/03/12	2022/03/11
<input checked="" type="checkbox"/>	Power Meter	NRP2	A140401673	2021/03/12	2022/03/11
<input checked="" type="checkbox"/>	Power Sensor	NPR-Z11	1138.3004.02-114072-nq	2021/03/12	2022/03/11
<input checked="" type="checkbox"/>	Power Meter	NRVS	A0802531	2021/03/12	2022/03/11
<input checked="" type="checkbox"/>	Power Sensor	NRV-Z4	100069	2021/03/12	2022/03/11



ANNEX A: Appendix A: SAR System performance Check Plots

(Please See Appendix A)

ANNEX B: Appendix B: SAR Measurement results Plots

(Please See Appendix B)

ANNEX C: Appendix C: Calibration reports

(Please See Appendix C)

ANNEX D: Appendix D: SAR Test Setup

(Please See Appendix D)

—End of the Report—