



TEST REPORT

Report Reference No...... : **CHEW21110244** Report Verification: 
Project No...... : **SHT2109071201EW**
FCC ID..... : **2AJZP-A4100**
Applicant's name..... : **Mason America, Inc**
 Address..... : 2101 4TH AVE STE 1550 SEATTLE, WA 98121-2316
Test item description : **Mason Wearable**
 Trade Mark : Mason
 Model/Type reference..... : A4100
 Listed Model(s) : -
Standard : **47 CFR FCC Part 15 Subpart B**
 Date of receipt of test sample..... : Sep. 29, 2021
 Date of testing..... : Sep. 30, 2021- Nov. 30, 2021
 Date of issue..... : Dec. 01, 2021
Result..... : **Pass**

Compiled by
 (position+printed name+signature)...: File administrators Silvia Li
 Supervised by
 (position+printed name+signature)...: Project Engineer Aaron Fang
 Approved by
 (position+printed name+signature)...: RF Manager Hans Hu

Silvia Li

Aaron.Fang

Hans Hu

Testing Laboratory Name : **Shenzhen Huatongwei International Inspection Co., Ltd.**
 Address..... : 1/F, Bldg 3, Hongfa Hi-tech Industrial Park, Genyu Road, Tianliao,
 Gongming, Shenzhen, China

Shenzhen Huatongwei International Inspection Co., Ltd. All rights reserved.

This publication may be reproduced in whole or in part for non-commercial purposes as long as the Shenzhen Huatongwei International Inspection Co., Ltd. is acknowledged as copyright owner and source of the material. Shenzhen Huatongwei International Inspection Co., Ltd. takes no responsibility for and will not assume liability for damages resulting from the reader's interpretation of the reproduced material due to its placement and context.

The test report merely corresponds to the test sample.

Contents

1.	<u>TEST STANDARDS AND REPORT VERSION</u>	<u>3</u>
1.1.	Test Standards	3
1.2.	Report version information	3
2.	<u>TEST DESCRIPTION</u>	<u>4</u>
3.	<u>SUMMARY.....</u>	<u>5</u>
3.1.	Client Information	5
3.2.	Product Description	5
3.3.	EUT operation mode	5
4.	<u>TEST ENVIRONMENT</u>	<u>6</u>
4.1.	Testing Laboratory Information	6
4.2.	Environmental conditions	6
4.3.	Statement of the measurement uncertainty	6
4.4.	Equipments Used during the Test	7
5.	<u>TEST CONDITIONS AND RESULTS</u>	<u>8</u>
5.1.	Conducted Emissions Test	8
5.2.	Radiated Emissions Test	11
6.	<u>TEST SETUP PHOTOS OF THE EUT</u>	<u>15</u>
7.	<u>EXTERNAL AND INTERNAL PHOTOS OF THE EUT</u>	<u>16</u>

1. TEST STANDARDS AND REPORT VERSION

1.1. Test Standards

The tests were performed according to following standards:

[47 CFR FCC Part 15 Subpart B](#) - Unintentional Radiators

[ANSI C63.4: 2014](#) – American National Standard for Methods of Measurement of Radio-Noise Emissions from Low-Voltage Electrical and Electronic Equipment in the Range of 9 kHz to 40GHz

1.2. Report version information

Revision No.	Date of issue	Description
N/A	2021-12-01	Original

2. TEST DESCRIPTION

Test Item	Section in CFR 47	Result	Test Engineer
Conducted Emissions	15.107(a)	PASS	Jiongsheng Feng
Radiated Emissions	15.109(a)	PASS	Pan Xie

Note: The measurement uncertainty is not included in the test result.

3. SUMMARY

3.1. Client Information

Applicant:	Mason America, Inc
Address:	2101 4TH AVE STE 1550 SEATTLE, WA 98121-2316
Manufacturer:	Mason America, Inc
Address:	2101 4TH AVE STE 1550 SEATTLE, WA 98121-2316

3.2. Product Description

Name of EUT:	Mason Wearable
Trade Mark:	Mason
Model No.:	A4100
Listed Model(s)	-
Power supply:	DC 3.85V
Adapter information:	Model: TPA-147C050100UU01 Input: AC100-240V, 50/60Hz, 0.2A Output: 5.0Vdc, 1.0A

3.3. EUT operation mode

Test mode	Describe
Camera recording mode	Keep the EUT in Camera recording status
Video Playing mode	Keep the EUT in Video Playing status

Pre-scan all of above modes. Only show Camera recording mode which is the worst case on the report.

4. TEST ENVIRONMENT

4.1. Testing Laboratory Information

Laboratory Name	Shenzhen Huatongwei International Inspection Co., Ltd.	
Laboratory Location	1/F, Bldg 3, Hongfa Hi-tech Industrial Park, Genyu Road, Tianliao, Gongming, Shenzhen, China	
Connect information:	Tel: 86-755-26715499 E-mail: cs@szhtw.com.cn http://www.szhtw.com.cn	
Qualifications	Type	Accreditation Number
	FCC	762235

4.2. Environmental conditions

During the measurement the environmental conditions were within the listed ranges:

Temperature:	15~35°C
Relative Humidity:	30~60 %
Air Pressure:	950~1050mba

4.3. Statement of the measurement uncertainty

The data and results referenced in this document are true and accurate. The reader is cautioned that there may be errors within the calibration limits of the equipment and facilities. The measurement uncertainty was calculated for all measurements listed in this test report acc. to CISPR 16 - 4 „Specification for radio disturbance and immunity measuring apparatus and methods – Part 4: Uncertainty in EMC Measurements“ and is documented in the Shenzhen Huatongwei International Inspection Co., Ltd quality system acc. to DIN EN ISO/IEC 17025. Furthermore, component and process variability of devices similar to that tested may result in additional deviation. The manufacturer has the sole responsibility of continued compliance of the device.

Hereafter the best measurement capability for Shenzhen Huatongwei laboratory is reported:

Test	Range	Measurement Uncertainty	Notes
Radiated Emissions	30~1000MHz	4.90 dB	(1)
Radiated Emissions	1~18GHz	4.96 dB	(1)
Conducted Disturbance	0.15~30MHz	3.02 dB	(1)

(1) This uncertainty represents an expanded uncertainty expressed at approximately the 95% confidence level using a coverage factor of k=1.96.

4.4. Equipments Used during the Test

● Conducted Emission							
Used	Test Equipment	Manufacturer	Equipment No.	Model No.	Serial No.	Last Cal. Date (YY-MM-DD)	Next Cal. Date (YY-MM-DD)
●	Shielded Room	Albatross projects	HTWE0114	N/A	N/A	2018/09/28	2023/09/27
●	EMI Test Receiver	R&S	HTWE0111	ESCI	101247	2021/9/14	2022/9/13
●	Artificial Mains	SCHWARZBECK	HTWE0113	NNLK 8121	573	2021/9/17	2022/9/16
●	Pulse Limiter	R&S	HTWE0033	ESH3-Z2	100499	2021/9/13	2022/9/12
●	RF Connection Cable	HUBER+SUHNER	HTWE0113-02	ENVIROFLE X_142	EF-NM-BNCM-2M	2021/9/17	2022/9/16
●	Test Software	R&S	N/A	ES-K1	N/A	N/A	N/A

● Radiated Emission-6th test site							
Used	Test Equipment	Manufacturer	Equipment No.	Model No.	Serial No.	Last Cal. Date (YY-MM-DD)	Next Cal. Date (YY-MM-DD)
●	Semi-Anechoic Chamber	Albatross projects	HTWE0127	SAC-3m-02	C11121	2018/09/30	2022/09/29
●	EMI Test Receiver	R&S	HTWE0099	ESCI	100900	2021/9/14	2022/9/13
●	Ultra-Broadband Antenna	SCHWARZBECK	HTWE0119	VULB9163	546	2020/04/28	2023/04/27
●	Pre-Amplifier	SCHWARZBECK	HTWE0295	BBV 9742	N/A	2021/11/5	2022/11/4
●	RF Connection Cable	HUBER+SUHNER	HTWE0062-01	N/A	N/A	2021/02/26	2022/02/25
●	RF Connection Cable	HUBER+SUHNER	HTWE0062-02	SUCOFLEX104	501184/4	2021/02/26	2022/02/25
●	Test Software	R&S	N/A	ES-K1	N/A	N/A	N/A

● Radiated emission-7th test site							
Used	Test Equipment	Manufacturer	Equipment No.	Model No.	Serial No.	Last Cal. Date (YY-MM-DD)	Next Cal. Date (YY-MM-DD)
●	Semi-Anechoic Chamber	Albatross projects	HTWE0122	SAC-3m-01	N/A	2018/09/27	2022/09/26
●	Spectrum Analyzer	R&S	HTWE0098	FSP40	100597	2021/9/13	2022/9/12
●	Horn Antenna	SCHWARZBECK	HTWE0126	9120D	1011	2020/04/01	2023/03/31
●	Broadband Pre-amplifier	SCHWARZBECK	HTWE0201	BBV 9718	9718-248	2021/03/05	2022/03/04
●	RF Connection Cable	HUBER+SUHNER	HTWE0121-01	RE-7-FH	N/A	2021/03/05	2022/03/04
●	Test Software	Audix	N/A	E3	N/A	N/A	N/A

5. TEST CONDITIONS AND RESULTS

5.1. Conducted Emissions Test

LIMIT

FCC CFR Title 47 Part 15 Subpart B Section 15.107:

Frequency range (MHz)	Limit (dBuV)	
	Quasi-peak	Average
0.15-0.5	66 to 56*	56 to 46*
0.5-5	56	46
5-30	60	50

* Decreases with the logarithm of the frequency.

TEST CONFIGURATION

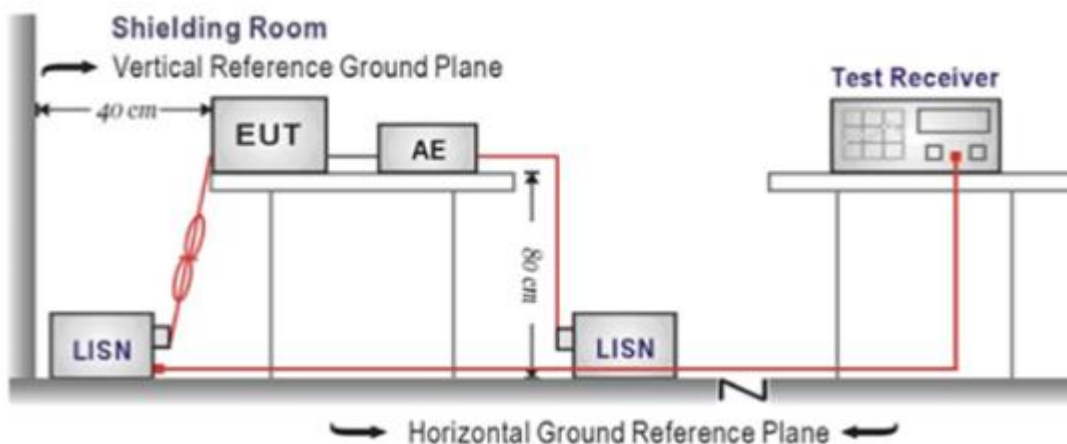

TEST PROCEDURE

1. The EUT was setup according to ANSI C63.4:2014
2. The EUT was placed on a plat form of nominal size, 1 m by 1.5 m, raised 10 cm above the conducting ground plane. The vertical conducting plane was located 40 cm to the rear of the EUT. All other surfaces of EUT were at least 10 cm from any other grounded conducting surface.
3. The EUT and simulators are connected to the main power through a line impedance stabilization network (LISN). The LISN provides a 50ohm / 50uH coupling impedance for the measuring equipment.
4. The peripheral devices are also connected to the main power through a LISN. (Please refer to the block diagram of the test setup and photographs)
5. Each current-carrying conductor of the EUT power cord, except the ground (safety) conductor, was individually connected through a LISN to the input power source.
6. The excess length of the power cord between the EUT and the LISN receptacle were folded back and forth at the center of the lead to form a bundle not exceeding 40 cm in length.
7. Conducted emissions were investigated over the frequency range from 0.15MHz to 30MHz using a receiver bandwidth of 9 kHz.
8. During the above scans, the emissions were maximized by cable manipulation.

TEST MODE:

Please refer to the clause 3.3

TEST RESULTS

Passed Not Applicable

Test Line:

L

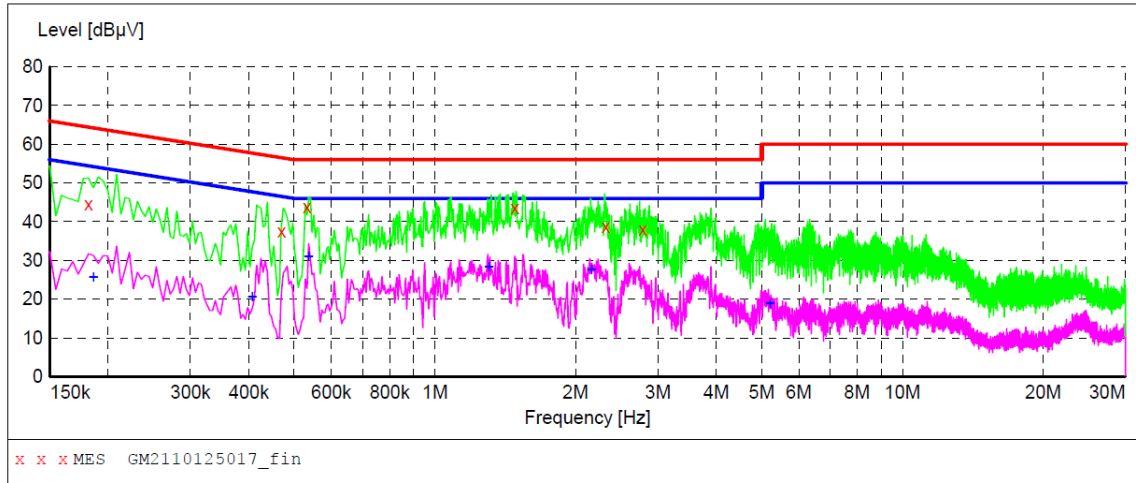

MEASUREMENT RESULT: "GM2110125017_fin"

10/12/2021 2:11PM

Frequency MHz	Level dBµV	Transd dB	Limit dBµV	Margin dB	Detector	Line	PE
0.181500	44.50	10.2	64	19.9	QP	L1	GND
0.469500	37.50	10.2	57	19.0	QP	L1	GND
0.532500	43.80	10.2	56	12.2	QP	L1	GND
1.482000	43.50	10.2	56	12.5	QP	L1	GND
2.319000	38.80	10.2	56	17.2	QP	L1	GND
2.782500	37.90	10.2	56	18.1	QP	L1	GND

MEASUREMENT RESULT: "GM2110125017_fin2"

10/12/2021 2:11PM

Frequency MHz	Level dBµV	Transd dB	Limit dBµV	Margin dB	Detector	Line	PE
0.186000	25.70	10.2	54	28.5	AV	L1	GND
0.406500	20.70	10.2	48	27.0	AV	L1	GND
0.537000	31.00	10.2	46	15.0	AV	L1	GND
1.306500	28.30	10.2	46	17.7	AV	L1	GND
2.161500	27.50	10.2	46	18.5	AV	L1	GND
5.203500	18.90	10.2	50	31.1	AV	L1	GND

Test Line:

N

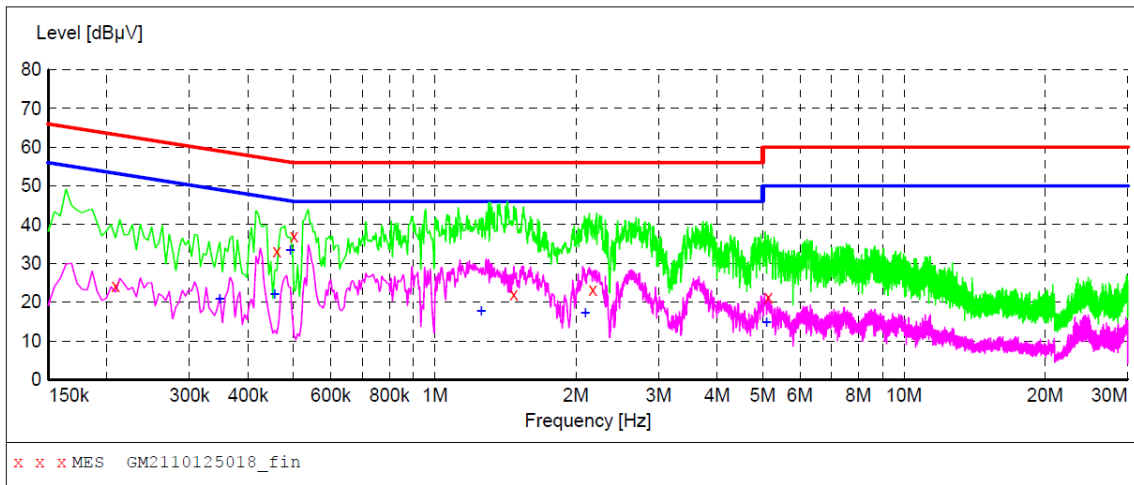

MEASUREMENT RESULT: "GM2110125018_fin"

10/12/2021 2:14PM

Frequency MHz	Level dBµV	Transd dB	Limit dBµV	Margin dB	Detector	Line	PE
0.208500	24.30	10.2	63	39.0	QP	N	GND
0.460500	33.10	10.2	57	23.6	QP	N	GND
0.501000	37.10	10.2	56	18.9	QP	N	GND
1.473000	22.10	10.2	56	33.9	QP	N	GND
2.170500	23.30	10.2	56	32.7	QP	N	GND
5.145000	21.30	10.2	60	38.7	QP	N	GND

MEASUREMENT RESULT: "GM2110125018_fin2"

10/12/2021 2:14PM

Frequency MHz	Level dBµV	Transd dB	Limit dBµV	Margin dB	Detector	Line	PE
0.348000	20.90	10.2	49	28.1	AV	N	GND
0.456000	22.00	10.2	47	24.8	AV	N	GND
0.492000	33.40	10.2	46	12.7	AV	N	GND
1.257000	17.60	10.2	46	28.4	AV	N	GND
2.094000	17.30	10.2	46	28.7	AV	N	GND
5.091000	14.80	10.2	50	35.2	AV	N	GND

5.2. Radiated Emissions Test

LIMIT

FCC CFR Title 47 Part 15 Subpart B Section 15.109

Frequency	Limit (dBuV/m @3m)	Value
30MHz-88MHz	40.00	Quasi-peak
88MHz-216MHz	43.50	Quasi-peak
216MHz-960MHz	46.00	Quasi-peak
960MHz-1GHz	54.00	Quasi-peak
Above 1GHz	54.00	Average
	74.00	Peak

TEST CONFIGURATION

➤ 30MHz ~ 1GHz

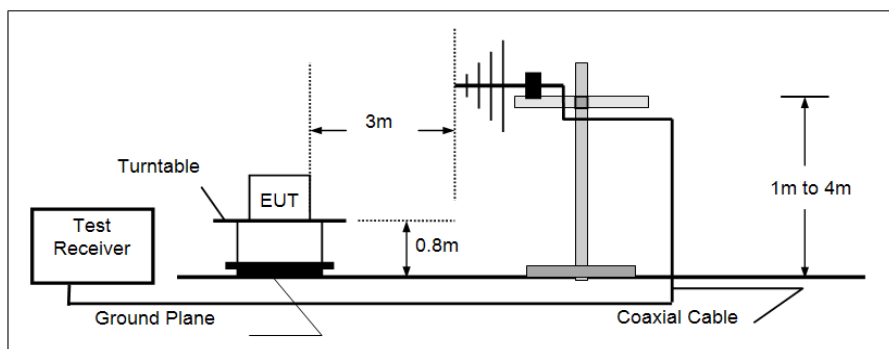

➤ Above 1GHz

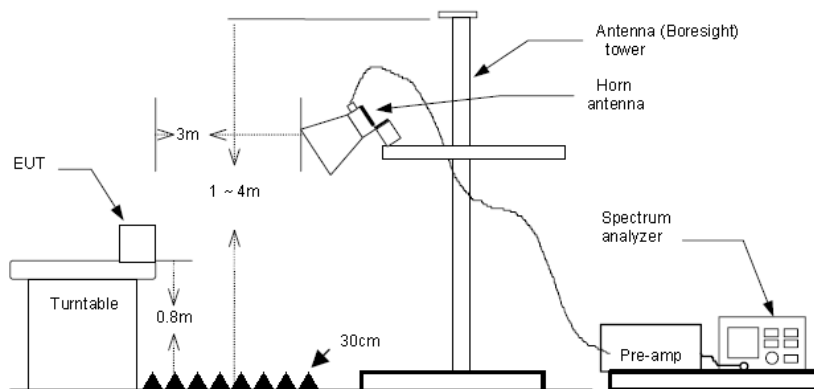

TEST PROCEDURE

- The EUT was tested according to ANSI C63.4:2014.
- The EUT is placed on a turn table which is 0.8 meter above ground.
- The turn table is rotated 360 degrees to determine the position of the maximum emission level.
- The EUT was positioned such that the distance from antenna to the EUT was 3 meters.
- The antenna is scanned from 1 meter to 4 meters to find out the maximum emission level. This is repeated for both horizontal and vertical polarization of the antenna.
- Use the following spectrum analyzer settings
 - Span shall wide enough to fully capture the emission being measured;
 - Below 1GHz,
 - RBW=120KHz, VBW=300KHz, Sweep=auto, Detector function=peak, Trace=max hold;
 - If the emission level of the EUT measured by the peak detector is 3 dB lower than the applicable limit, the peak emission level will be reported. Otherwise, the emission measurement will be repeated using the quasi-peak detector and reported.
 - From 1GHz to 5th harmonic, RBW=1MHz, VBW=3MHz

TEST MODE:

Please refer to the clause 3.3

TEST RESULTS

Passed **Not Applicable**

Note: Final Level = Receiver Read level + Antenna Factor + Cable Loss – Preamplifier Factor
The emission levels of frequency above 6GHz are very lower than limit and not show in test report.

Polarization: Horizontal

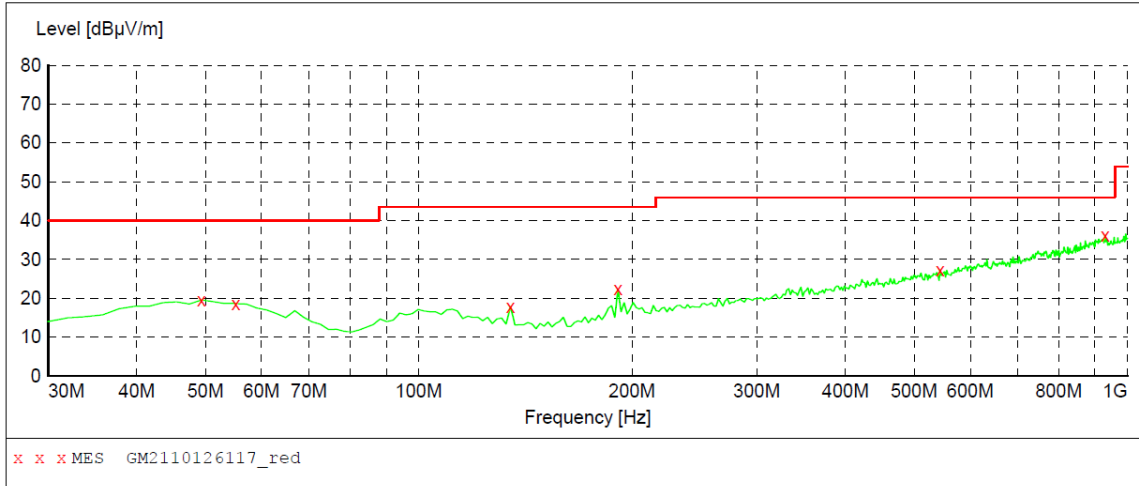

MEASUREMENT RESULT: "GM2110126117_red"

10/12/2021 10:10PM

Frequency MHz	Level dBµV/m	Transd dB	Limit dBµV/m	Margin dB	Det.	Height cm	Azimuth deg	Polarization
49.400000	19.60	-8.8	40.0	20.4	QP	100.0	51.00	HORIZONTAL
55.220000	18.60	-9.1	40.0	21.4	QP	300.0	75.00	HORIZONTAL
134.760000	17.90	-13.9	43.5	25.6	QP	300.0	354.00	HORIZONTAL
191.020000	22.30	-10.8	43.5	21.2	QP	300.0	100.00	HORIZONTAL
544.100000	27.30	-0.6	46.0	18.7	QP	300.0	320.00	HORIZONTAL
930.160000	36.30	7.7	46.0	9.7	QP	300.0	6.00	HORIZONTAL

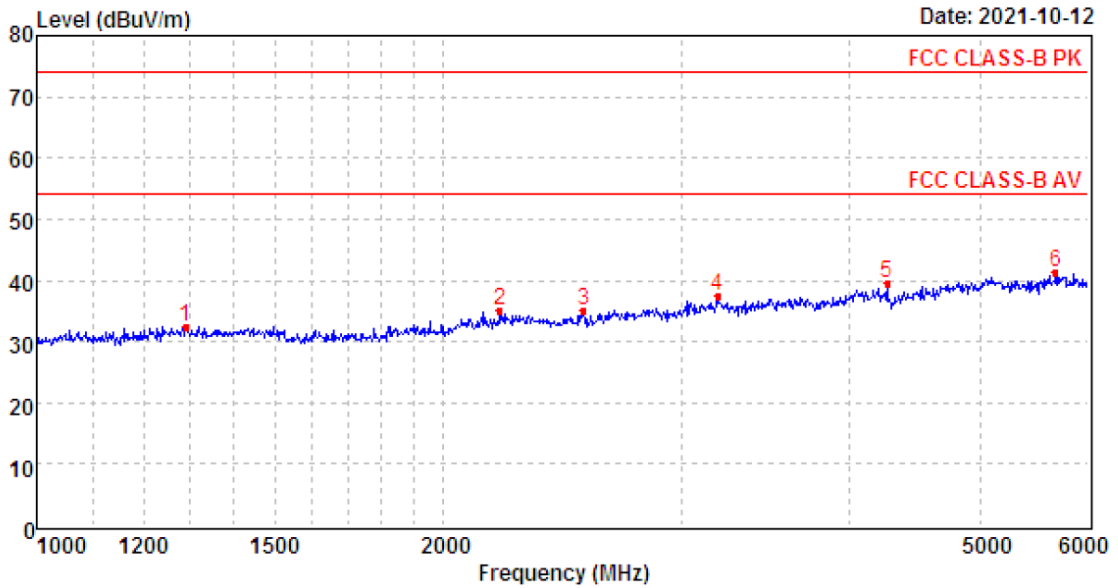

Mark	Frequency MHz	Reading dBuV/m	Antenna dB	Cable dB	Preamp dB	Level dBuV/m	Limit dBuV/m	Over limit	Remark
1	1289.73	38.87	25.98	4.01	36.33	32.53	74.00	-41.47	Peak
2	2203.76	38.98	28.19	5.31	37.41	35.07	74.00	-38.93	Peak
3	2538.86	39.18	27.40	5.73	37.16	35.15	74.00	-38.85	Peak
4	3193.32	39.25	28.91	6.45	37.01	37.60	74.00	-36.40	Peak
5	4261.13	37.76	30.22	7.73	36.12	39.59	74.00	-34.41	Peak
6	5675.82	34.76	31.90	9.51	34.95	41.22	74.00	-32.78	Peak

Polarization:

Vertical

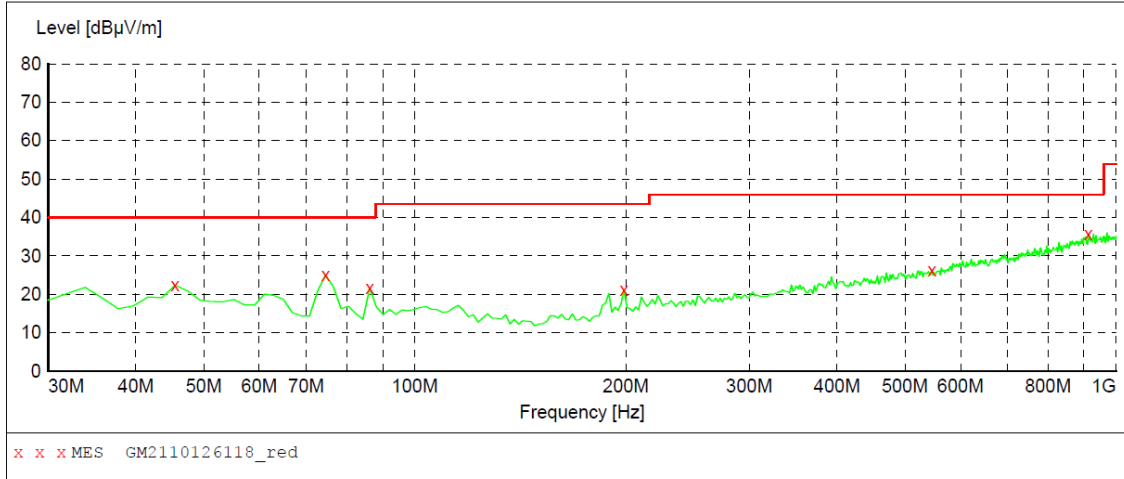

MEASUREMENT RESULT: "GM2110126118_red"

10/12/2021 10:12PM

Frequency MHz	Level dBuV/m	Transd dB	Limit dBuV/m	Margin dB	Det.	Height cm	Azimuth deg	Polarization
45.520000	22.40	-8.8	40.0	17.6	QP	100.0	323.00	VERTICAL
74.620000	25.00	-14.8	40.0	15.0	QP	100.0	163.00	VERTICAL
86.260000	21.60	-14.0	40.0	18.4	QP	100.0	260.00	VERTICAL
198.780000	21.10	-9.7	43.5	22.4	QP	100.0	0.00	VERTICAL
546.040000	26.30	-0.6	46.0	19.7	QP	100.0	152.00	VERTICAL
912.700000	35.70	7.6	46.0	10.3	QP	100.0	0.00	VERTICAL

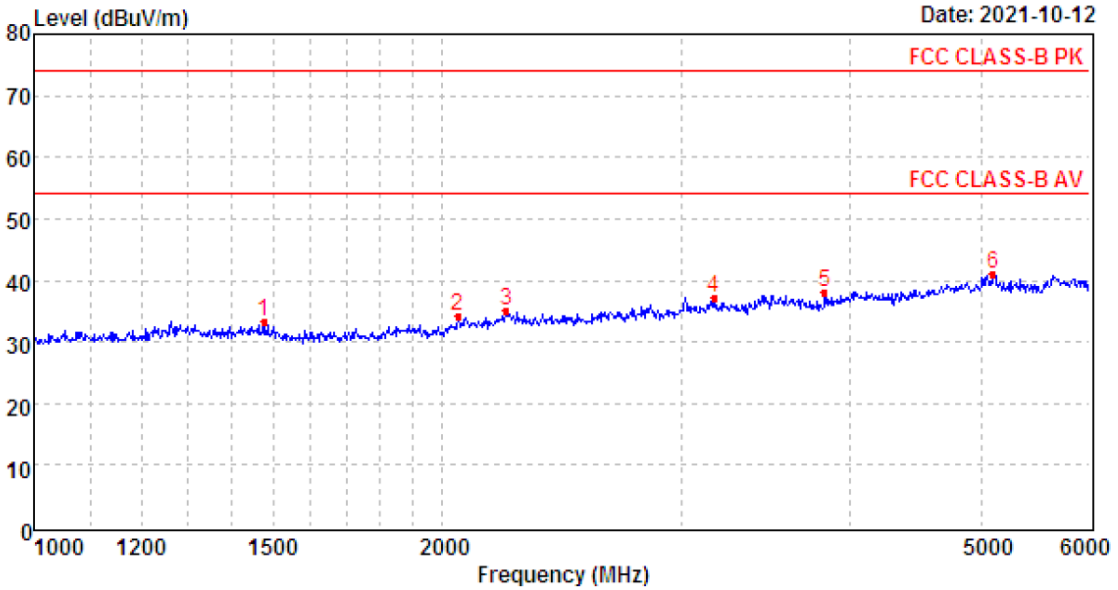

Mark	Frequency MHz	Reading dBuV/m	Antenna dB	Cable dB	Preamp dB	Level dBuV/m	Limit dBuV/m	Over limit	Remark
1	1477.87	39.95	25.99	4.29	36.80	33.43	74.00	-40.57	Peak
2	2055.02	39.80	26.56	5.09	37.14	34.31	74.00	-39.69	Peak
3	2231.58	39.07	28.14	5.34	37.41	35.14	74.00	-38.86	Peak
4	3170.51	38.80	28.96	6.41	37.11	37.06	74.00	-36.94	Peak
5	3826.80	38.06	29.71	7.17	36.96	37.98	74.00	-36.02	Peak
6	5097.29	35.50	32.20	8.93	35.48	41.15	74.00	-32.85	Peak

6. TEST SETUP PHOTOS OF THE EUT

Conducted Emissions (AC Mains)



Radiated Emissions (30MHz-1GHz)

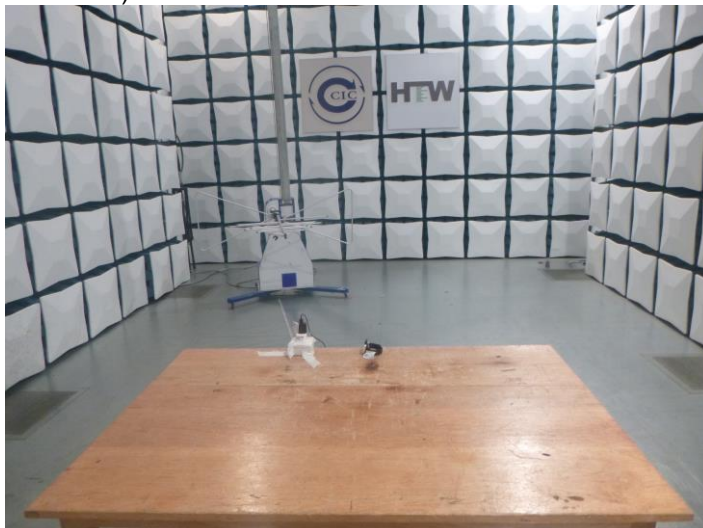

Radiated Emissions (Above 1GHz)

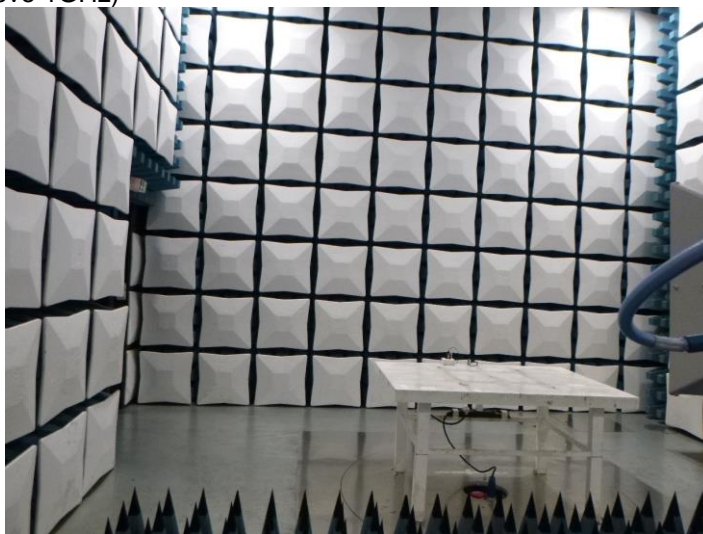

7. EXTERNAL AND INTERNAL PHOTOS OF THE EUT

Reference to the test report No.: CHTEW21110239

-----End of Report-----