



FCC RADIO TEST REPORT

FCC ID : 2AJZB-0308
Equipment : Digital Media Streaming Device
Model Name : EX69VW
Applicant : Verdegrass LLC
233 South 13th Street, Suite 1100, Lincoln,
Nebraska 68508
Standard : FCC Part 15 Subpart E §15.407

The product was completed on Aug. 21, 2017. We, SPORTON INTERNATIONAL INC., would like to declare that the tested sample has been evaluated in accordance with the test procedures and has been in compliance with the applicable technical standards.

The report must not be used by the client to claim product certification, approval, or endorsement by TAF or any agency of government.

The test results in this report apply exclusively to the tested model / sample. Without written approval of SPORTON INTERTIONAL INC. EMC & Wireless Communications Laboratory, the test report shall not be reproduced except in full.

Approved by: Jones Tsai

SPORTON INTERTIONAL INC. EMC & Wireless Communications Laboratory

No. 52, Huaya 1st Rd., Guishan Dist., Taoyuan City, Taiwan (R.O.C.)



Table of Contents

History of this test report	3
Summary of Test Result	4
1 General Description	5
1.1 Product Feature of Equipment Under Test.....	5
1.2 Product Specification of Equipment Under Test.....	5
1.3 Modification of EUT.....	5
1.4 Testing Location.....	6
1.5 Applicable Standards	6
2 Test Configuration of Equipment Under Test	7
2.1 Carrier Frequency and Channel	7
2.2 Test Mode	8
2.3 Connection Diagram of Test System.....	9
2.4 Support Unit used in test configuration and system.....	10
2.5 EUT Operation Test Setup	10
2.6 Measurement Results Explanation Example.....	10
3 Test Result.....	11
3.1 26dB & 99% Occupied Bandwidth Measurement	11
3.2 Maximum Conducted Output Power Measurement	13
3.3 Power Spectral Density Measurement	14
3.4 Unwanted Emissions Measurement	16
3.5 AC Conducted Emission Measurement.....	21
3.6 Automatically Discontinue Transmission	23
3.7 Antenna Requirements	25
4 List of Measuring Equipment	26
5 Uncertainty of Evaluation	27
Appendix A. Conducted Test Results	
Appendix B. AC Conducted Emission Test Results	
Appendix C. Radiated Spurious Emission	
Appendix D. Radiated Spurious Emission Plots	
Appendix E. Duty Cycle Plots	



History of this test report

Report No.	Version	Description	Issued Date
FR742534-04A	01	Initial issue of report	May 18, 2018



Summary of Test Result

Report Clause	Ref Std. Clause	Test Items	Result (PASS/FAIL)
3.1	15.403(i)	26dB Bandwidth	Pass
3.1	2.1049	99% Occupied Bandwidth	Reporting only
3.2	15.407(a)	Maximum Conducted Output Power	Pass
3.3	15.407(a)	Power Spectral Density	Pass
3.4	15.407(b)	Unwanted Emissions	Pass
3.5	15.207	AC Conducted Emission	Pass
3.6	15.407(c)	Automatically Discontinue Transmission	Pass
3.7	15.203 15.407(a)	Antenna Requirement	Pass

Reviewed by: Louis Wu

Report Producer: Wii Chang



1 General Description

1.1 Product Feature of Equipment Under Test

Product Feature	
Equipment	Digital Media Streaming Device
Model Name	EX69VW
FCC ID	2AJZB-0308
EUT supports Radios application	WLAN 11a/b/g/n HT20 HT40 WLAN 11ac VHT20/VHT40/VHT80 Bluetooth BR/EDR/LE

1.2 Product Specification of Equipment Under Test

Standards-related Product Specification							
Tx/Rx Frequency Range	5180 MHz ~ 5240 MHz						
Maximum Output Power to Antenna <CDD Modes>	MIMO <Ant. 1 + 2> 802.11a : 21.34 dBm / 0.1361 W 802.11n HT20 : 21.21 dBm / 0.1321 W 802.11n HT40 : 18.86 dBm / 0.0769 W 802.11ac VHT20: 21.32 dBm / 0.1355 W 802.11ac VHT40: 18.82 dBm / 0.0762 W 802.11ac VHT80: 11.54 dBm / 0.0143 W						
99% Occupied Bandwidth	MIMO<Ant. 1> 802.11a : 18.45 MHz 802.11n HT20 : 19.15 MHz 802.11n HT40 : 36.80 MHz 802.11ac VHT80: 75.96 MHz MIMO<Ant. 2> 802.11a : 18.60 MHz 802.11n HT20 : 19.25 MHz 802.11n HT40 : 36.80 MHz 802.11ac VHT80: 75.84 MHz						
Antenna Type / Gain	Ant. 1 : Fixed internal Antenna with gain 3.19 dBi Ant. 2 : Fixed internal Antenna with gain 4.88 dBi						
Type of Modulation	802.11a/n : OFDM (BPSK / QPSK / 16QAM / 64QAM) 802.11ac : OFDM (BPSK / QPSK / 16QAM / 64QAM / 256QAM)						
Antenna Function Description	<table border="1"> <thead> <tr> <th></th> <th>Ant. 1</th> <th>Ant. 2</th> </tr> </thead> <tbody> <tr> <td>802.11 a/n/ac MIMO</td> <td>V</td> <td>V</td> </tr> </tbody> </table>		Ant. 1	Ant. 2	802.11 a/n/ac MIMO	V	V
	Ant. 1	Ant. 2					
802.11 a/n/ac MIMO	V	V					

Note: MIMO Ant. 1+2 is a calculated result from sum of the power MIMO Ant. 1 and MIMO Ant. 2.

1.3 Modification of EUT

No modifications are made to the EUT during all test items.



1.4 Testing Location

Sporton Lab is accredited to ISO 17025 by Taiwan Accreditation Foundation (TAF code : 1190) and the FCC designation No. TW1190 and TW0007 under the FCC 2.948(e) by Mutual Recognition Agreement (MRA) in FCC Test.

Test Site	SPORTON INTERNATIONAL INC.	
Test Site Location	No.52, Huaya 1st Rd., Guishan Dist., Taoyuan City, Taiwan (R.O.C.) TEL: +886-3-327-3456 FAX: +886-3-328-4978	
Test Site No.	Sporton Site No.	
	TH05-HY	CO05-HY

Note: The test site complies with ANSI C63.4 2014 requirement.

Test Site	SPORTON INTERNATIONAL INC.	
Test Site Location	No.58, Aly. 75, Ln. 564, Wenhua 3rd, Rd., Guishan Dist., Taoyuan City, Taiwan (R.O.C.) TEL: +886-3-327-3456 FAX: +886-3-328-4978	
Test Site No.	Sporton Site No.	
	03CH13-HY	

Note: The test site complies with ANSI C63.4 2014 requirement.

1.5 Applicable Standards

According to the specifications of the manufacturer, the EUT must comply with the requirements of the following standards:

- ♦ FCC Part 15 Subpart E
- ♦ FCC KDB 789033 D02 General UNII Test Procedures New Rules v02r01.
- ♦ FCC KDB 662911 D01 Multiple Transmitter Output v02r01.
- ♦ ANSI C63.10-2013

Remark: All test items were verified and recorded according to the standards and without any deviation during the test..



2 Test Configuration of Equipment Under Test

- a. The EUT has been associated with peripherals and configuration operated in a manner tended to maximize its emission characteristics in a typical application. Frequency range investigated: conduction emission (150 kHz to 30 MHz), radiation emission (9 kHz to the 10th harmonic of the highest fundamental frequency or to 40 GHz, whichever is lower). For radiated measurement, all the possible configuration was pre-scanned with power adaptor and peripherals (HDMI, USB and IR connector). It was determined that the worst configuration was EUT with adaptor but no peripherals. The final radiated testing was performed with EUT with adaptor but no peripherals.

- b. AC power line Conducted Emission was tested under maximum output power.

2.1 Carrier Frequency and Channel

Frequency Band	Channel	Freq. (MHz)	Channel	Freq. (MHz)
5150-5250 MHz Band 1 (U-NII-1)	36	5180	44	5220
	38*	5190	46*	5230
	-	-	48	5240
	42#	5210		

Note:

- 1. The above Frequency and Channel in "*" were 802.11n HT40 and 802.11ac VHT40.
- 2. The above Frequency and Channel in "#n" were 802.11ac VHT80.



2.2 Test Mode

Final test mode of conducted test items and radiated spurious emissions are considering the modulation and worse data rates as below table.

MIMO Antenna

Modulation	Data Rate
802.11a	6 Mbps
802.11n HT20	MCS0
802.11n HT40	MCS0
802.11ac VHT20	MCS0
802.11ac VHT40	MCS0
802.11ac VHT80	MCS0

Test Cases	
AC Conducted Emission	Mode 1 : WLAN (5GHz) Link + Bluetooth Link + LED on + MPEG4 (Maximum Resolution) + IR on + Adapter

Ch. #	Band I : 5150-5250 MHz			
	802.11a	802.11n HT20	802.11n HT40	802.11ac VHT80
L Low	36	36	38	-
M Middle	44	44	-	42
H High	48	48	46	-

2.3 Connection Diagram of Test System

<WLAN Tx Mode>

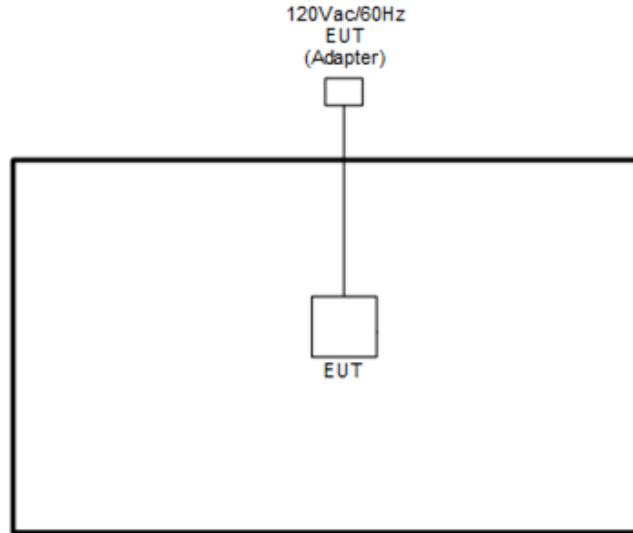

<AC Conducted Emission Mode>

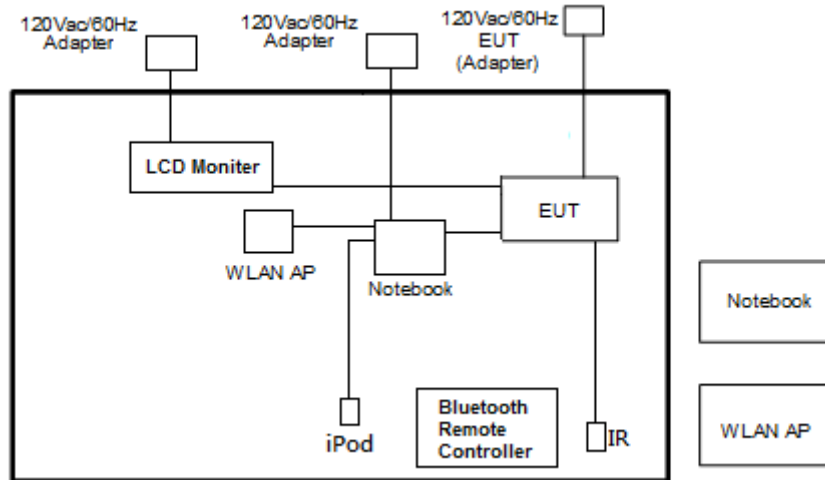



2.4 Support Unit used in test configuration and system

Item	Equipment	Trade Name	Model Name	FCC ID	Data Cable	Power Cord
1.	WLAN AP	ASUS	RT-AC66U	MSQ-RTAC66U	N/A	Unshielded, 1.8 m
2.	iPod	Apple	A1285	DoC	Shielded, 1.0m	N/A
3.	NOTE BOOK	DELL	E5570	FCC DoC	N/A	AC I/P: Unshielded, 1.2 m DC O/P: Shielded, 1.8 m
4.	NOTE BOOK	DELL	Latitude E6320	FCC DoC	N/A	AC I/P: Unshielded, 1.2 m DC O/P: Shielded, 1.8 m
5.	LCD Monitor	Sony	KD-55X8500D	FCC DoC	Shielded, 1.6 m	Unshielded, 1.8 m

2.5 EUT Operation Test Setup

The RF test items, programmed RF utility, "CMD" installed in the notebook make the EUT provide functions like channel selection and power level for continuous transmitting and receiving signals.

2.6 Measurement Results Explanation Example

For all conducted test items:

The offset level is set in the spectrum analyzer to compensate the RF cable loss and attenuator factor between EUT conducted output port and spectrum analyzer. With the offset compensation, the spectrum analyzer reading level is exactly the EUT RF output level.

Example :

The spectrum analyzer offset is derived from RF cable loss and attenuator factor.

Offset = RF cable loss + attenuator factor.

Following shows an offset computation example with cable loss 4.2 dB and 10dB attenuator.

$$\begin{aligned} \text{Offset(dB)} &= \text{RF cable loss(dB)} + \text{attenuator factor(dB)}. \\ &= 4.2 + 10 = 14.2 \text{ (dB)} \end{aligned}$$

3 Test Result

3.1 26dB & 99% Occupied Bandwidth Measurement

3.1.1 Description of 26dB & 99% Occupied Bandwidth

This section is for reporting purpose only.
There is no restriction limits for bandwidth.

3.1.2 Measuring Instruments

The measuring equipment is listed in the section 4 of this test report.

3.1.3 Test Procedures

1. The testing follows FCC KDB 789033 D02 General UNII Test Procedures New Rules v02r01. Section C) Emission bandwidth
2. Set RBW = approximately 1% of the emission bandwidth.
3. Set the VBW > RBW.
4. Detector = Peak.
5. Trace mode = max hold
6. Measure the maximum width of the emission that is 26 dB down from the peak of the emission. Compare this with the RBW setting of the analyzer. Readjust RBW and repeat measurement as needed until the RBW/EBW ratio is approximately 1%.
7. For 99% Bandwidth Measurement, the spectrum analyzer's resolution bandwidth (RBW) is set 1MHz and set the Video bandwidth (VBW) $\geq 3 * RBW$.
8. Measure and record the results in the test report.

3.1.4 Test Setup

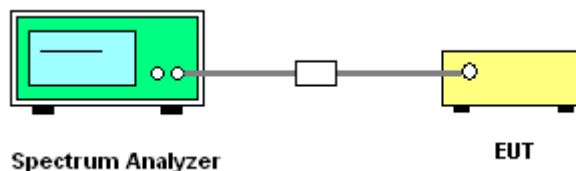



3.1.5 Test Result of 26dB & 99% Occupied Bandwidth

Please refer to Appendix A.

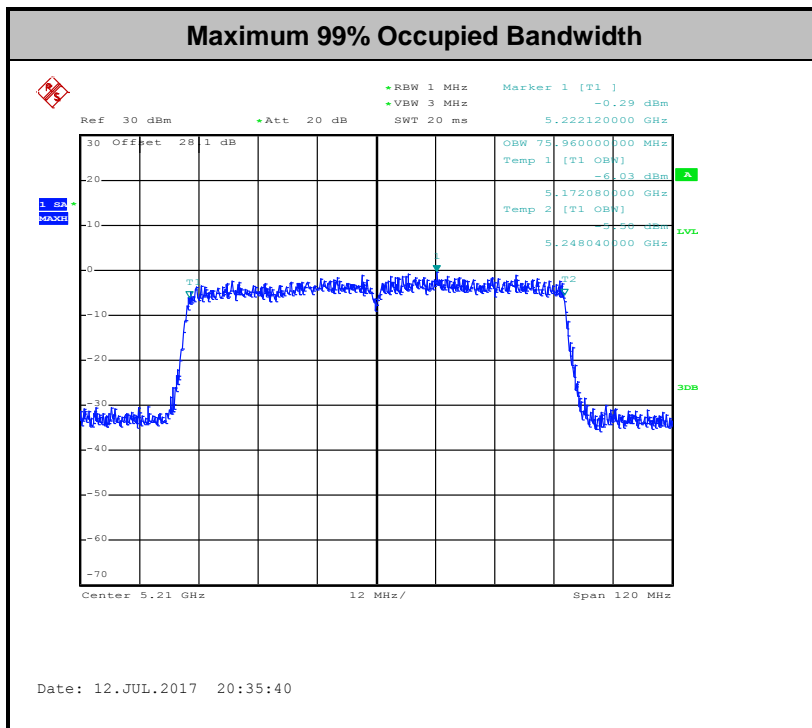
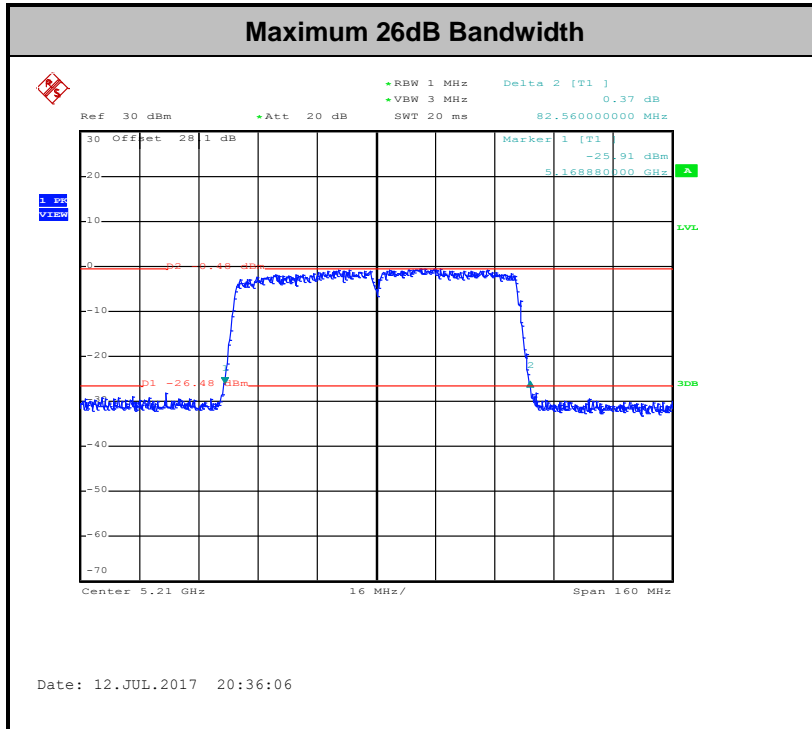

Note: The occupied channel bandwidth is maintained within the band of operation for all of the modulations.

3.2 Maximum Conducted Output Power Measurement

3.2.1 Limit of Maximum Conducted Output Power

<FCC 14-30 CFR 15.407>

For the 5.15–5.25 GHz bands:

- For mobile and portable client devices in the 5.15–5.25 GHz band, the maximum conducted output power over the frequency band of operation shall not exceed 250 mW. For an indoor access point operating in the band 5.15-5.25 GHz, the maximum conducted output power over the frequency band of operation shall not exceed 1 W.

If transmitting antennas of directional gain greater than 6 dBi are used, the peak output power shall be reduced by the amount in dB that the directional gain of the antenna exceeds 6 dBi.

3.2.2 Measuring Instruments

The measuring equipment is listed in the section 4 of this test report.

3.2.3 Test Procedures

CDD modes

The testing follows Method PM of FCC KDB 789033 D02 General UNII Test Procedures New Rules v02r01 for CDD modes.

Method PM (Measurement using an RF average power meter):

1. Measurement is performed using a wideband RF power meter.
2. The EUT is configured to transmit continuously with a consistent duty cycle at its maximum power control level.
3. Measure the average power of the transmitter, and the average power is corrected with duty factor, $10 \log(1/x)$, where x is the duty cycle.

3.2.4 Test Setup

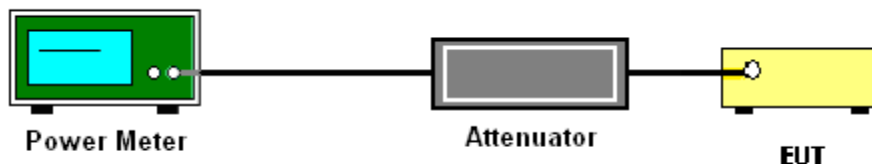

3.2.5 Test Result of Maximum Conducted Output Power

Please refer to Appendix A.



3.3 Power Spectral Density Measurement

3.3.1 Limit of Power Spectral Density

<FCC 14-30 CFR 15.407>

For the 5.15–5.25 GHz bands:

For mobile and portable client devices in the 5.15–5.25 GHz band, the maximum power spectral density shall not exceed 11 dBm in any 1.0 MHz band. For an indoor access point operating in the band 5.15-5.25 GHz, the maximum power spectral density shall not exceed 17 dBm in any 1.0 MHz band.

If transmitting antennas of directional gain greater than 6 dBi are used, the peak output power shall be reduced by the amount in dB that the directional gain of the antenna exceeds 6 dBi.

3.3.2 Measuring Instruments

The measuring equipment is listed in the section 4 of this test report.

3.3.3 Test Procedures

The testing follows FCC KDB 789033 D02 General UNII Test Procedures New Rules v02r01.

Section F) Maximum power spectral density.

CDD modes

Method SA-2

(trace averaging across on and off times of the EUT transmissions, followed by duty cycle correction).

- Measure the duty cycle.
 - Set span to encompass the entire emission bandwidth (EBW) of the signal.
 - Set RBW = 1 MHz.
 - Set VBW \geq 3 MHz.
 - Number of points in sweep \geq 2 Span / RBW.
 - Sweep time = auto.
 - Detector = RMS
 - Trace average at least 100 traces in power averaging mode.
 - Add $10 \log(1/x)$, where x is the duty cycle, to the measured power in order to compute the average power during the actual transmission times. For example, add $10 \log(1/0.25) = 6$ dB if the duty cycle is 25 percent.
1. The RF output of EUT was connected to the spectrum analyzer by a low loss cable.
 2. Each plot has already offset with cable loss, and attenuator loss. Measure the PPSD and record it.

3. For MIMO mode, calculation method follows FCC KDB 662911 D01 Multiple Transmitter Output v02r01.

Method (a): Measure and sum the spectra across the outputs.

The total final Power Spectral Density is from a device with 2 transmitter outputs. The spectrum measurements of the individual outputs are all performed with the same span and number of points, the spectrum value in the first spectral bin of output 1 is summed with that in the first spectral bin of output 2 to obtain the value for the first frequency bin of the summed spectrum.

3.3.4 Test Setup

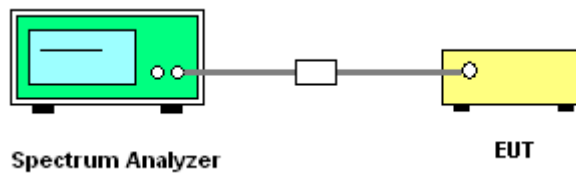

3.3.5 Test Result of Power Spectral Density

Please refer to Appendix A.

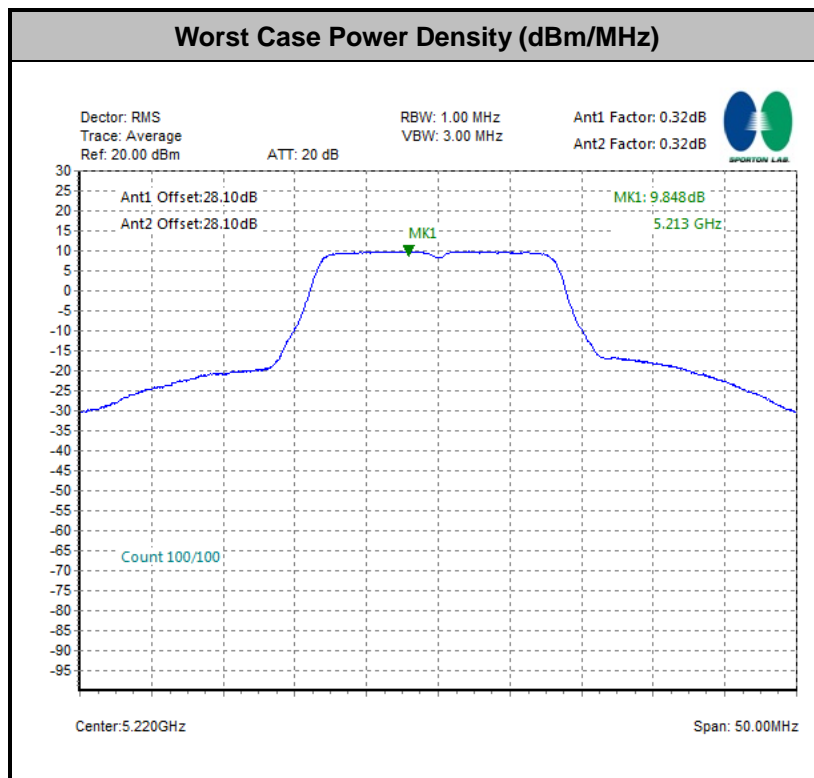

Note: Average Power Density (dB) = Measured value+ Duty Factor



3.4 Unwanted Emissions Measurement

This section is to measure unwanted emissions through radiated measurement for band edge spurious emissions and out of band emissions measurement.

3.4.1 Limit of Unwanted Emissions

- (1) For transmitters operating in the 5150-5250 MHz band: all emissions outside of the 5150-5350 MHz band shall not exceed an EIRP of -27dBm/MHz.
- (2) Unwanted spurious emissions fallen in restricted bands shall comply with the general field strength limits as below table.

Frequency (MHz)	Field Strength (microvolts/meter)	Measurement Distance (meters)
0.009 – 0.490	2400/F(kHz)	300
0.490 – 1.705	24000/F(kHz)	30
1.705 – 30.0	30	30
30 – 88	100	3
88 – 216	150	3
216 - 960	200	3
Above 960	500	3

Note: The following formula is used to convert the EIRP to field strength.

$$E = \frac{1000000\sqrt{30P}}{3} \mu V/m, \text{ where } P \text{ is the eirp (Watts)}$$

EIRP (dBm)	Field Strength at 3m (dBμV/m)
- 27	68.3



(1) KDB789033 D02 v02r01 G)2)c)

- (i) Section 15.407(b)(1) to (b)(3) specify the unwanted emission limits for the U-NII-1 and U-NII-2 bands. As specified, emissions above 1000 MHz that are outside of the restricted bands are subject to a peak emission limit of -27 dBm/MHz.³
- (ii) Section 15.407(b)(4) specifies the unwanted emission limit for the U-NII-3 band. A band emissions mask is specified in Section 15.407(b)(4)(i). The emission limits are in terms of a Peak detector. An alternative to the band emissions mask is specified in Section 15.407(b)(4)(ii). The alternative limits are based on the highest antenna gain specified in the filing. There are also marketing and importation restrictions for the devices using the alternative limit.⁴

Note 3: An out-of-band emission that complies with both the average and peak limits of Section 15.209 is not required to satisfy the -27 dBm/MHz peak emission limit.

Note 4: Only devices with antenna gains of 10 dBi or less may be approved using the emission limits specified in Section 15.247(d) till March 2, 2018; all other devices operating in this band must use the mask specified in Section 15.407(b)(4)(i).

3.4.2 Measuring Instruments

The measuring equipment is listed in the section 4 of this test report.

3.4.3 Test Procedures

1. The testing follows FCC KDB 789033 D02 General UNII Test Procedures New Rules v02r01. Section G) Unwanted emissions measurement.

(1) Procedure for Unwanted Emissions Measurements Below 1000MHz

- RBW = 120 kHz
- VBW = 300 kHz
- Detector = Peak
- Trace mode = max hold

(2) Procedure for Peak Unwanted Emissions Measurements Above 1000 MHz

- RBW = 1 MHz
- VBW ≥ 3 MHz
- Detector = Peak
- Sweep time = auto
- Trace mode = max hold



(3) Procedures for Average Unwanted Emissions Measurements Above 1000MHz

- RBW = 1 MHz
 - VBW = 10 Hz, when duty cycle is no less than 98 percent.
 - $VBW \geq 1/T$, when duty cycle is less than 98 percent where T is the minimum transmission duration over which the transmitter is on and is transmitting at its maximum power control level for the tested mode of operation.
2. The EUT was placed on a turntable with 0.8 meter for frequency below 1GHz and 1.5 meter for frequency above 1GHz respectively above ground.
 3. The EUT was set 3 meters from the interference receiving antenna which was mounted on the top of a variable height antenna tower.
 4. The antenna is a broadband antenna and its height is adjusted between one meter and four meters above ground to find the maximum value of the field strength for both horizontal polarization and vertical polarization of the antenna.
 5. For each suspected emission, the EUT was arranged to its worst case and then adjust the antenna tower (from 1 m to 4 m) and turntable (from 0 degree to 360 degrees) to find the maximum reading.
 6. For testing below 1GHz, if the emission level of the EUT in peak mode was 3 dB lower than the limit specified, then peak values of EUT will be reported, otherwise, the emissions will be repeated one by one using the CISPR quasi-peak method and reported.
 7. For testing above 1GHz, the emission level of the EUT in peak mode was 20dB lower than average limit (that means the emission level in average mode also complies with the limit in average mode), then peak values of EUT will be reported, otherwise, the emissions will be measured in average mode again and reported.

3.4.4 Test Setup

For radiated emissions below 30MHz

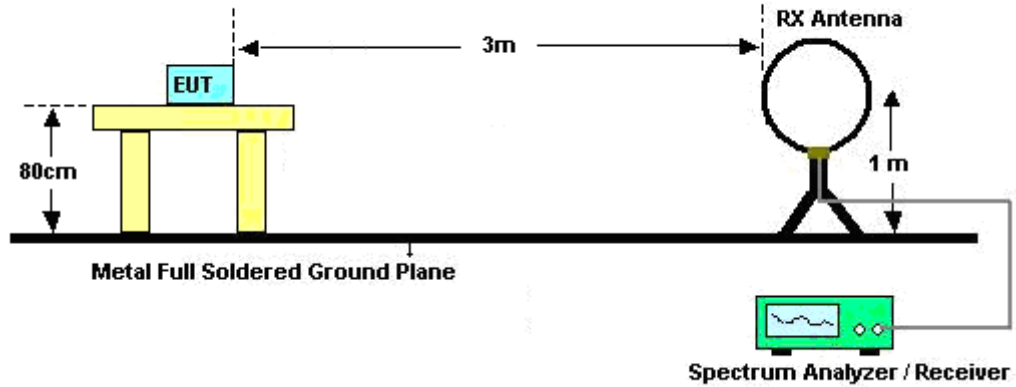

For radiated emissions from 30MHz to 1GHz

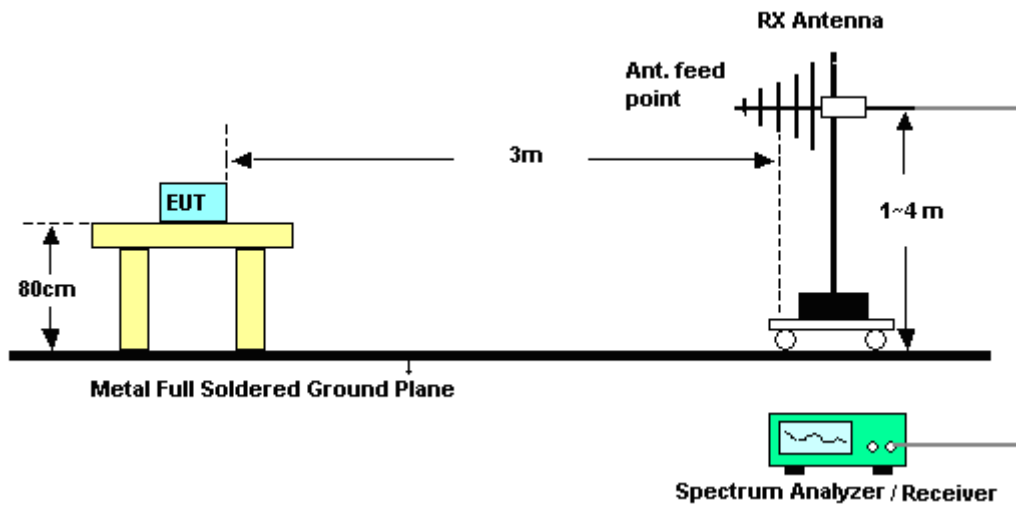

For radiated emissions above 1GHz

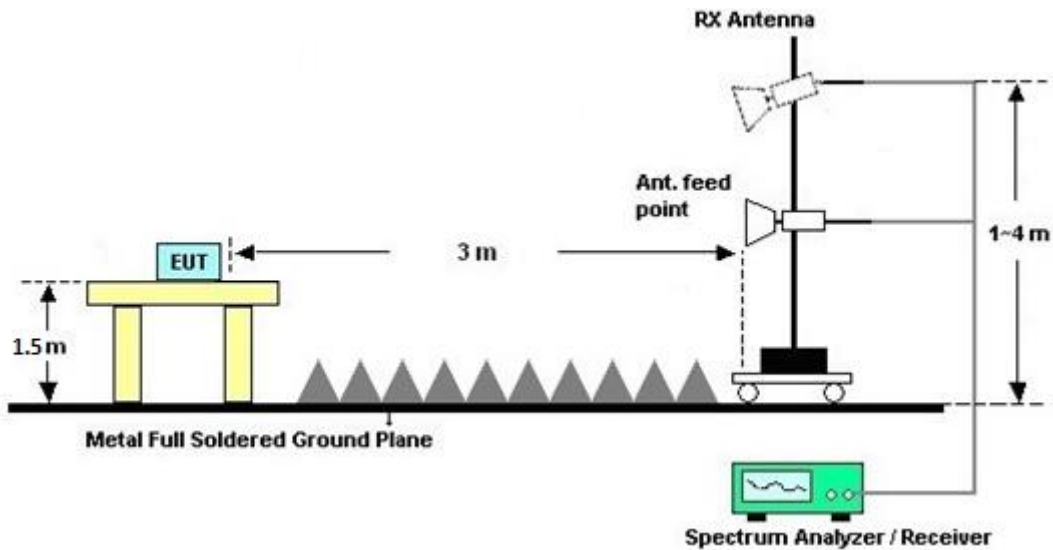

3.4.5 Test Results of Radiated Spurious Emissions (9 kHz ~ 30 MHz)

The low frequency, which started from 9 kHz to 30MHz, was pre-scanned and the result which was 20dB lower than the limit line was not reported.

There is a comparison data of both open-field test site and semi-Anechoic chamber, and the result came out very similar.

3.4.6 Test Result of Radiated Spurious at Band Edges

Please refer to Appendix C and D.

3.4.7 Duty Cycle

Please refer to Appendix E.

3.4.8 Test Result of Radiated Spurious Emissions (30MHz ~ 10th Harmonic)

Please refer to Appendix C and D.



3.5 AC Conducted Emission Measurement

3.5.1 Limit of AC Conducted Emission

For equipment that is designed to be connected to the public utility (AC) power line, the radio frequency voltage that is conducted back onto the AC power line on any frequency or frequencies within the band 150 kHz to 30 MHz shall not exceed the limits in the following table.

Frequency of emission (MHz)	Conducted limit (dB μ V)	
	Quasi-peak	Average
0.15-0.5	66 to 56*	56 to 46*
0.5-5	56	46
5-30	60	50

*Decreases with the logarithm of the frequency.

3.5.2 Measuring Instruments

The measuring equipment is listed in the section 4 of this test report.

3.5.3 Test Procedures

1. The EUT was placed 0.4 meter from the conducting wall of the shielding room was kept at least 80 centimeters from any other grounded conducting surface.
2. Connect EUT to the power mains through a line impedance stabilization network (LISN).
3. All the support units are connecting to the other LISN.
4. The LISN provides 50 ohm coupling impedance for the measuring instrument.
5. The FCC states that a 50 ohm, 50 microhenry LISN should be used.
6. Both sides of AC line were checked for maximum conducted interference.
7. The frequency range from 150 kHz to 30 MHz was searched.
8. Set the test-receiver system to Peak Detect Function and specified bandwidth with Maximum Hold Mode.

3.5.4 Test Setup

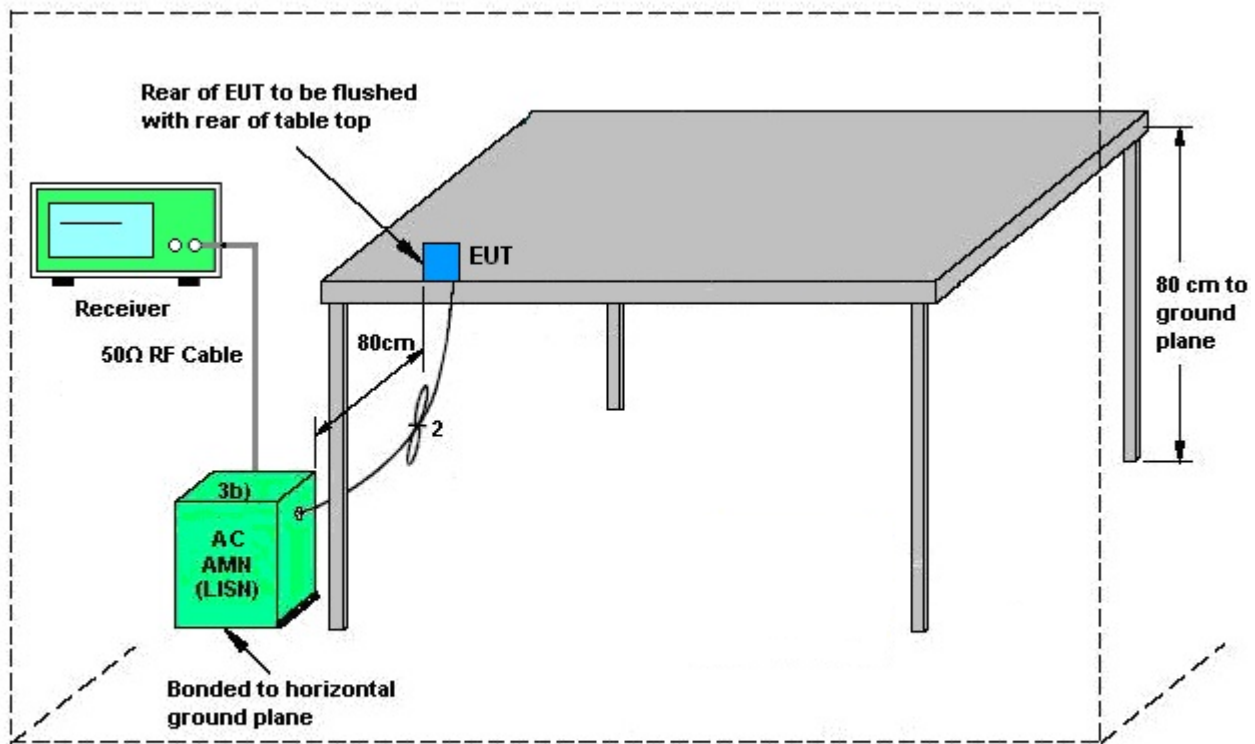

AMN = Artificial mains network (LISN)
AE = Associated equipment
EUT = Equipment under test
ISN = Impedance stabilization network

3.5.5 Test Result of AC Conducted Emission

Please refer to Appendix B.



3.6 Automatically Discontinue Transmission

3.6.1 Limit of Automatically Discontinue Transmission

The device shall automatically discontinue transmission in case of either absence of information to transmit or operational failure. These provisions are not intended to preclude the transmission of control or signaling information or the use of repetitive codes used by certain digital technologies to complete frame or burst intervals. Applicants shall include in their application for equipment authorization to describe how this requirement is met.

3.6.2 Measuring Instruments

The measuring equipment is listed in the section 4 of this test report.

3.6.3 Test Result of Automatically Discontinue Transmission

EUT is verified this characteristic during the function check of normal sample associated with an access point:

- A. Information start: make EUT supply information to the access point.
- B. Information stop: stop supplying information to the access point.

While the EUT is not transmitting any information, the EUT can automatically discontinue transmission and become standby mode for power saving.

- C. Information start: make EUT supply information to the access point again.

The EUT can detect the controlling signal of ACK message transmitting from remote device and verify whether it shall resend or discontinue transmission.

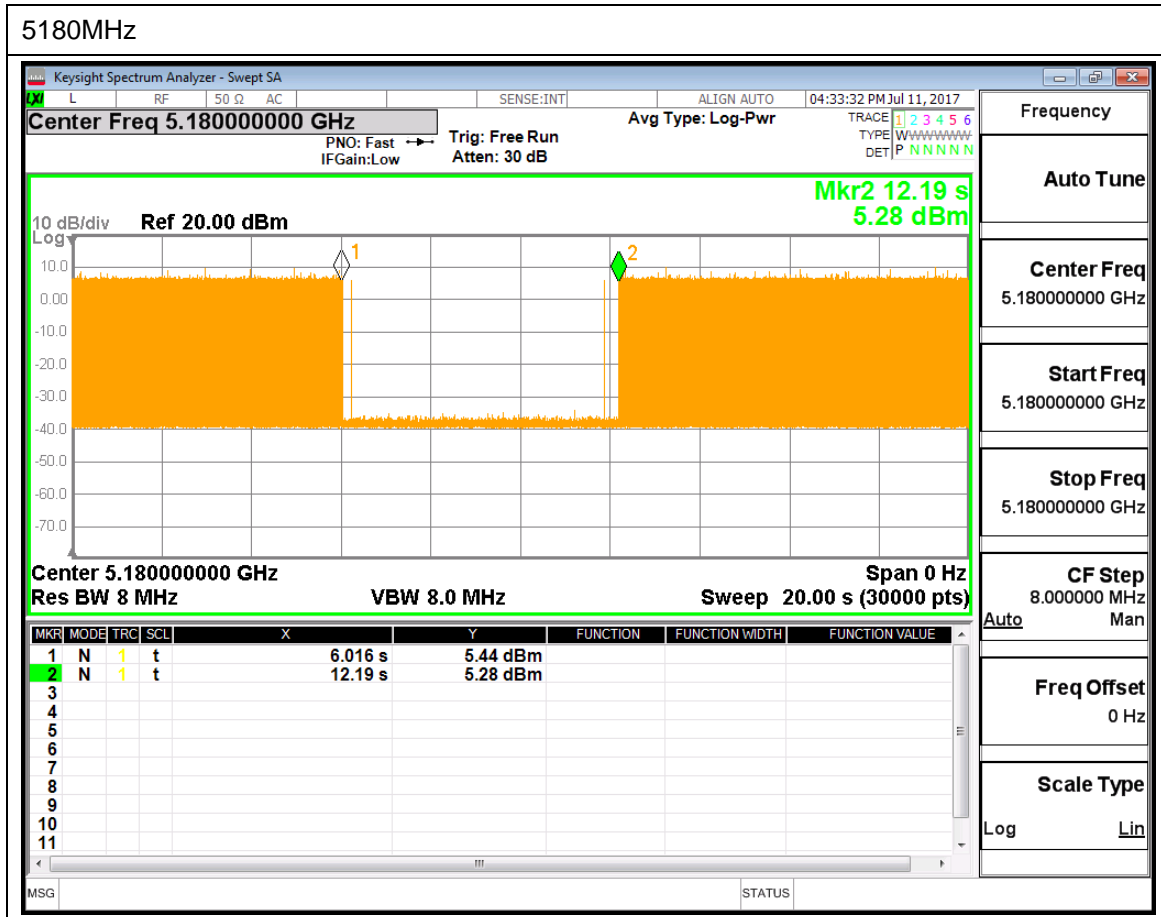

Note : The control / signalling information during the period B is precluded.



3.7 Antenna Requirements

3.7.1 Standard Applicable

If transmitting antenna directional gain is greater than 6 dBi, both the peak transmit power and the peak power spectral density shall be reduced by the amount in dB that the directional gain of the antenna exceeds 6 dBi.

3.7.2 Antenna Anti-Replacement Construction

An embedded-in antenna design is used.

3.7.3 Antenna Gain

CDD modes

FCC KDB 662911 D01 Multiple Transmitter Output v02r01

For CDD transmissions, directional gain is calculated as

Directional gain = $G_{ANT} + \text{Array Gain}$, where Array Gain is as follows.

For power spectral density (PSD) measurements on all devices,

Array Gain = $10 \log(N_{ANT}/N_{SS}=1)$ dB.

For power measurements on IEEE 802.11 devices,

Array Gain = 0 dB (i.e., no array gain) for $N_{ANT} \leq 4$.

Directional gain may be calculated by using the formulas applicable to equal gain antennas with G_{ANT} set equal to the gain of the antenna having the highest gain;

The EUT supports CDD mode.

For power, the directional gain G_{ANT} is set equal to the antenna having the highest gain, i.e., F)2)f)i).

For PSD, the directional gain calculation is following F)2)f)ii) of KDB 662911 D01 v02r01.

The power and PSD limit should be modified if the directional gain of EUT is over 6 dBi,

The directional gain "DG" is calculated as following table.

			DG	DG	Power	PSD
			for	for	Limit	Limit
	Ant 1	Ant 2	Power	PSD	Reduction	Reduction
	(dBi)	(dBi)	(dBi)	(dBi)	(dB)	(dB)
Band I	3.19	4.88	4.88	7.09	0.00	1.09

Power limit reduction = Composite gain – 6dBi, (min = 0)

PSD limit reduction = Composite gain + PSD Array gain – 6dBi, (min = 0)



4 List of Measuring Equipment

Instrument	Manufacturer	Model No.	Serial No.	Characteristics	Calibration Date	Test Date	Due Date	Remark
Power Meter	Anritsu	ML2495A	0932001	300MHz~40GHz	Sep. 29, 2016	Jul. 05, 2017~ Aug. 21, 2017	Sep. 28, 2017	Conducted (TH05-HY)
Power Sensor	Anritsu	MA2411B	0846202	300MHz~40GHz	Sep. 29, 2016	Jul. 05, 2017~ Aug. 21, 2017	Sep. 28, 2017	Conducted (TH05-HY)
Spectrum Analyzer	Rohde & Schwarz	FSP40	100057	9kHz-40GHz	Nov. 25, 2016	Jul. 05, 2017~ Aug. 21, 2017	Nov. 24, 2017	Conducted (TH05-HY)
Temperature Chamber	ESPEC	SH-641	92013720	-40℃ ~90℃	Sep. 01, 2016	Jul. 05, 2017~ Aug. 21, 2017	Aug. 31, 2017	Conducted (TH05-HY)
Programmable Power Supply	GW Instek	PSS-2005	EL890094	1V~20V 0.5A~5A	Oct. 11, 2016	Jul. 05, 2017~ Aug. 21, 2017	Oct. 10, 2017	Conducted (TH05-HY)
AC Power Source	AC POWER	AFC-500W	F104070011	50Hz~60Hz	Dec. 01, 2016	Jul. 05, 2017~ Aug. 21, 2017	Nov. 30, 2017	Conducted (TH05-HY)
AC Power Source	ChainTek	APC-1000W	N/A	N/A	N/A	Jul. 07, 2017	N/A	Conduction (CO05-HY)
EMI Test Receiver	Rohde & Schwarz	ESCI 7	100724	9kHz~7GHz	Aug. 30, 2016	Jul. 07, 2017	Aug. 29, 2017	Conduction (CO05-HY)
LISN	Rohde & Schwarz	ENV216	100080	9kHz~30MHz	Nov. 29, 2016	Jul. 07, 2017	Nov. 28, 2017	Conduction (CO05-HY)
LISN	Rohde & Schwarz	ENV216	100081	9kHz~30MHz	Dec. 06, 2016	Jul. 07, 2017	Dec. 05, 2017	Conduction (CO05-HY)
Spectrum Analyzer	Keysight	N9010A	MY55370526	N/A	Mar. 15, 2017	Jul. 07, 2017~ Jul. 30, 2017	Mar. 14, 2018	Radiation (03CH13-HY)
EMI Test Receiver	Agilent	N9038A(MXE)	MY53290053	20Hz to 26.5GHz	Jan. 12, 2017	Jul. 07, 2017~ Jul. 30, 2017	Jan. 11, 2018	Radiation (03CH13-HY)
Loop Antenna	Rohde & Schwarz	HFH2-Z2	100315	9 kHz~30 MHz	May 15, 2017	Jul. 07, 2017~ Jul. 30, 2017	May 14, 2019	Radiation (03CH13-HY)
Bilog Antenna	TESEQ	CBL 6111D&00800 N1D01N-06	40103&04	30MHz to 1GHz	Jan. 07, 2017	Jul. 07, 2017~ Jul. 30, 2017	Jan. 06, 2018	Radiation (03CH13-HY)
Horn Antenna	SCHWARZBECK	BBHA 9120 D	9120D-1241	1GHz ~ 18GHz	May 02, 2017	Jul. 07, 2017~ Jul. 30, 2017	May 01, 2018	Radiation (03CH13-HY)
SHF-EHF Horn Antenna	SCHWARZBECK	BBHA 9170	BBHA917058 4	18GHz- 40GHz	Nov. 08, 2016	Jul. 07, 2017~ Jul. 30, 2017	Nov. 07, 2017	Radiation (03CH13-HY)
Amplifier	Sonoma-Instrument	310 N	187282	9KHz~1GHz	Dec. 21, 2016	Jul. 07, 2017~ Jul. 30, 2017	Dec. 20, 2017	Radiation (03CH13-HY)
Preamplifier	Keysight	83017A	MY53270147	1GHz~26.5GHz	Jan. 09, 2017	Jul. 07, 2017~ Jul. 30, 2017	Jan. 08, 2018	Radiation (03CH13-HY)
Preamplifier	MITEQ	AMF-7D-0010 1800-30-10P	1590074	1GHz~18GHz	May 22, 2017	Jul. 07, 2017~ Jul. 30, 2017	May 21, 2018	Radiation (03CH13-HY)
Preamplifier	MITEQ	TTA 1840-35-HG	1887435	18GHz ~ 40GHz	Oct. 13, 2016	Jul. 07, 2017~ Jul. 30, 2017	Oct. 12, 2017	Radiation (03CH13-HY)
Antenna Mast	EMEC	AM-BS-4500-B	N/A	1m~4m	N/A	Jul. 07, 2017~ Jul. 30, 2017	N/A	Radiation (03CH13-HY)
Turn Table	EMEC	TT2000	N/A	0~360 Degree	N/A	Jul. 07, 2017~ Jul. 30, 2017	N/A	Radiation (03CH13-HY)



5 Uncertainty of Evaluation

Uncertainty of Conducted Emission Measurement (150kHz ~ 30MHz)

Measuring Uncertainty for a Level of Confidence of 95% ($U = 2Uc(y)$)	2.26
---	------

Uncertainty of Radiated Emission Measurement (30 MHz ~ 1000 MHz)

Measuring Uncertainty for a Level of Confidence of 95% ($U = 2Uc(y)$)	4.90
---	------

Uncertainty of Radiated Emission Measurement (1000 MHz ~ 18000 MHz)

Measuring Uncertainty for a Level of Confidence of 95% ($U = 2Uc(y)$)	5.40
---	------

Uncertainty of Radiated Emission Measurement (18000 MHz ~ 40000 MHz)

Measuring Uncertainty for a Level of Confidence of 95% ($U = 2Uc(y)$)	4.30
---	------

Appendix A. Test Result of Conducted Test Items

Test Engineer:	Aking chang	Temperature:	21~25	°C
Test Date:	2017/07/05~2017/08/21	Relative Humidity:	51~54	%

TEST RESULTS DATA
26dB and 99% OBW

Band I													
Mod.	Data Rate	NTX	CH.	Freq. (MHz)	99% Bandwidth (MHz)		26 dB Bandwidth (MHz)		IC 99% Bandwidth Power Limit (dBm)		IC 99% Bandwidth EIRP Limit (dBm)		Note
					Ant 1	Ant 2	Ant 1	Ant 2	Ant 1	Ant 2	Ant 1	Ant 2	
11a	6Mbps	2	36	5180	18.40	17.90	22.80	22.90	-	-	22.53	-	
11a	6Mbps	2	44	5220	18.45	18.35	27.10	34.75	-	-	22.64	-	
11a	6Mbps	2	48	5240	18.10	18.60	27.20	31.80	-	-	22.58	-	
HT20	MCS0	2	36	5180	19.15	18.85	23.45	23.10	-	-	22.75	-	
HT20	MCS0	2	44	5220	18.95	19.20	25.00	38.25	-	-	22.78	-	
HT20	MCS0	2	48	5240	19.05	19.25	32.20	42.45	-	-	22.80	-	
HT40	MCS0	2	38	5190	36.70	36.70	41.76	41.22	-	-	23.01	-	
HT40	MCS0	2	46	5230	36.80	36.80	41.40	41.04	-	-	23.01	-	
VHT80	MCS0	2	42	5210	75.96	75.84	82.56	82.24	-	-	23.01	-	

TEST RESULTS DATA
Average Power Table

FCC Band I														
Mod.	Data Rate	NTX	CH.	Freq. (MHz)	Duty Factor (dB)		Average Conducted Power (dBm)			FCC Conducted Power Limit (dBm)		DG (dBi)		Pass/Fail
					Ant 1	Ant 2	Ant 1	Ant 2	SUM	Ant 1	Ant 2	Ant 1	Ant 2	
11a	6Mbps	2	36	5180	0.32	0.32	13.85	14.31	17.10	24.00	24.00	4.88	4.88	Pass
11a	6Mbps	2	44	5220	0.32	0.32	17.62	18.94	21.34	24.00	24.00	4.88	4.88	Pass
11a	6Mbps	2	48	5240	0.32	0.32	17.50	18.93	21.29	24.00	24.00	4.88	4.88	Pass
HT20	MCS0	2	36	5180	0.34	0.34	13.80	14.27	17.05	24.00	24.00	4.88	4.88	Pass
HT20	MCS0	2	44	5220	0.34	0.34	17.53	18.77	21.21	24.00	24.00	4.88	4.88	Pass
HT20	MCS0	2	48	5240	0.34	0.34	17.94	19.33	21.70	24.00	24.00	4.88	4.88	Pass
HT40	MCS0	2	38	5190	0.67	0.67	9.02	9.97	12.53	24.00	24.00	4.88	4.88	Pass
HT40	MCS0	2	46	5230	0.67	0.67	15.22	16.39	18.86	24.00	24.00	4.88	4.88	Pass
VHT20	MCS0	2	36	5180	0.34	0.31	13.50	14.31	16.93	24.00	24.00	4.88	4.88	Pass
VHT20	MCS0	2	44	5220	0.34	0.31	17.59	18.72	21.20	24.00	24.00	4.88	4.88	Pass
VHT20	MCS0	2	48	5240	0.34	0.31	17.61	18.91	21.32	24.00	24.00	4.88	4.88	Pass
VHT40	MCS0	2	38	5190	0.60	0.66	8.95	9.96	12.50	24.00	24.00	4.88	4.88	Pass
VHT40	MCS0	2	46	5230	0.60	0.66	15.15	16.38	18.82	24.00	24.00	4.88	4.88	Pass
VHT80	MCS0	2	42	5210	1.20	1.14	7.96	9.04	11.54	24.00	24.00	4.88	4.88	Pass

TEST RESULTS DATA
Power Spectral Density

FCC Band I														
Mod.	Data Rate	NTX	CH.	Freq. (MHz)	Duty Factor (dB)		Average Power Density (dBm/MHz)			Average PSD Limit (dBm/MHz)		DG (dBi)		Pass /Fail
					Ant 1	Ant 2	Ant 1	Ant 2	SUM	Ant 1	Ant 2	Ant 1	Ant 2	
11a	6Mbps	2	36	5180	0.32	0.32			6.45	9.91	7.09		Pass	
11a	6Mbps	2	44	5220	0.32	0.32			9.85	9.91	7.09		Pass	
11a	6Mbps	2	48	5240	0.32	0.32			9.77	9.91	7.09		Pass	
HT20	MCS0	2	36	5180	0.34	0.34			6.40	9.91	7.09		Pass	
HT20	MCS0	2	44	5220	0.34	0.34			9.37	9.91	7.09		Pass	
HT20	MCS0	2	48	5240	0.34	0.34			9.78	9.91	7.09		Pass	
HT40	MCS0	2	38	5190	0.67	0.67			-1.64	9.91	7.09		Pass	
HT40	MCS0	2	46	5230	0.67	0.67			4.46	9.91	7.09		Pass	
VHT80	MCS0	2	42	5210	1.20	1.14			-5.19	9.91	7.09		Pass	



Appendix B. AC Conducted Emission Test Results

Test Engineer : Eric Jeng	Temperature :	22~24°C
	Relative Humidity :	51~53%

EUT Information

Test Mode : Mode 1
 Test Voltage : 120Vac/60Hz
 Phase : Line

ENV216 Auto Test FCC Power Bar - L

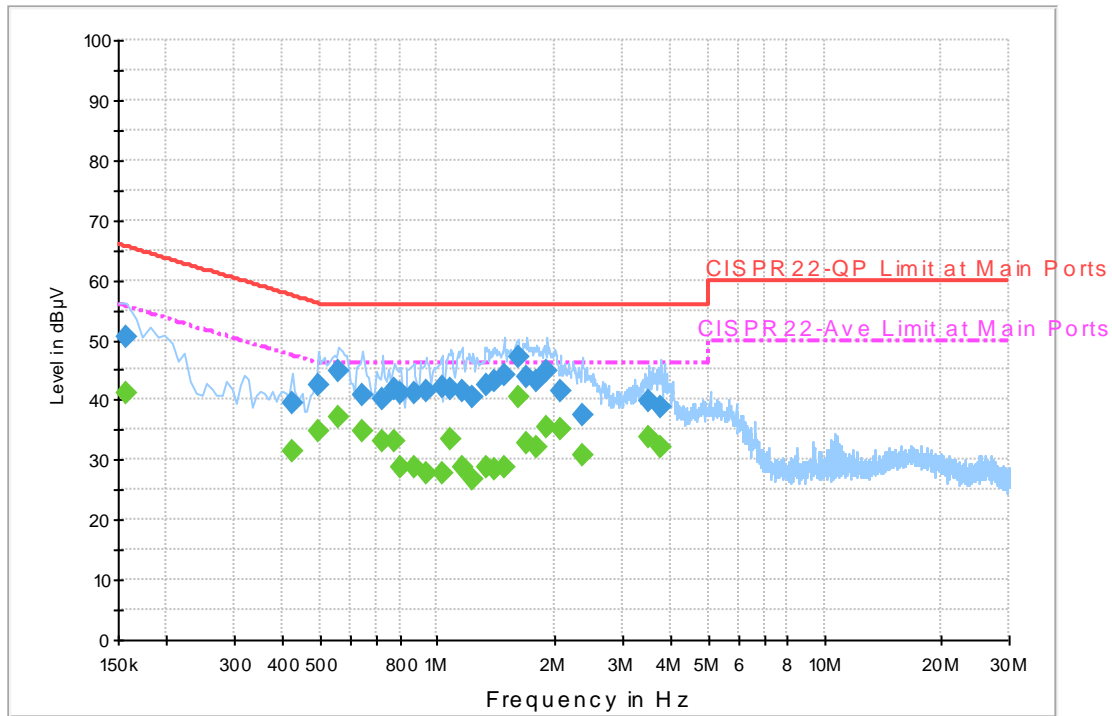

Final Result 1

Frequency (MHz)	QuasiPeak (dBµV)	Filter	Line	Corr. (dB)	Margin (dB)	Limit (dBµV)
0.158000	50.6	Off	L1	19.6	15.0	65.6
0.422000	39.6	Off	L1	19.6	17.8	57.4
0.494000	42.3	Off	L1	19.6	13.8	56.1
0.558000	44.9	Off	L1	19.6	11.1	56.0
0.638000	40.7	Off	L1	19.6	15.3	56.0
0.726000	40.1	Off	L1	19.6	15.9	56.0
0.774000	41.8	Off	L1	19.6	14.2	56.0
0.806000	41.3	Off	L1	19.6	14.7	56.0
0.870000	41.3	Off	L1	19.6	14.7	56.0
0.934000	41.5	Off	L1	19.6	14.5	56.0
1.030000	42.0	Off	L1	19.6	14.0	56.0
1.086000	41.8	Off	L1	19.6	14.2	56.0
1.158000	41.5	Off	L1	19.6	14.5	56.0
1.238000	40.4	Off	L1	19.6	15.6	56.0
1.334000	42.5	Off	L1	19.6	13.5	56.0
1.406000	43.1	Off	L1	19.6	12.9	56.0
1.486000	44.3	Off	L1	19.6	11.7	56.0
1.614000	47.1	Off	L1	19.6	8.9	56.0
1.710000	43.8	Off	L1	19.6	12.2	56.0
1.806000	43.2	Off	L1	19.6	12.8	56.0
1.926000	44.8	Off	L1	19.6	11.2	56.0
2.086000	41.5	Off	L1	18.0	14.5	56.0
2.366000	37.4	Off	L1	19.0	18.6	56.0
3.510000	39.7	Off	L1	19.7	16.3	56.0
3.798000	38.7	Off	L1	19.7	17.3	56.0

Final Result 2

Frequency (MHz)	Average (dB μ V)	Filter	Line	Corr. (dB)	Margin (dB)	Limit (dB μ V)
0.158000	41.2	Off	L1	19.6	14.4	55.6
0.422000	31.4	Off	L1	19.6	16.0	47.4
0.494000	34.8	Off	L1	19.6	11.3	46.1
0.558000	37.0	Off	L1	19.6	9.0	46.0
0.638000	34.9	Off	L1	19.6	11.1	46.0
0.726000	33.1	Off	L1	19.6	12.9	46.0
0.774000	33.1	Off	L1	19.6	12.9	46.0
0.806000	28.6	Off	L1	19.6	17.4	46.0
0.870000	28.7	Off	L1	19.6	17.3	46.0
0.934000	27.8	Off	L1	19.6	18.2	46.0
1.030000	27.7	Off	L1	19.6	18.3	46.0
1.086000	33.6	Off	L1	19.6	12.4	46.0
1.158000	28.8	Off	L1	19.6	17.2	46.0
1.238000	26.8	Off	L1	19.6	19.2	46.0
1.334000	28.7	Off	L1	19.6	17.3	46.0
1.406000	28.3	Off	L1	19.6	17.7	46.0
1.486000	28.7	Off	L1	19.6	17.3	46.0
1.614000	40.4	Off	L1	19.6	5.6	46.0
1.710000	32.7	Off	L1	19.6	13.3	46.0
1.806000	32.1	Off	L1	19.6	13.9	46.0
1.926000	35.6	Off	L1	19.6	10.4	46.0
2.086000	35.2	Off	L1	18.0	10.8	46.0
2.366000	30.7	Off	L1	19.0	15.3	46.0
3.510000	33.7	Off	L1	19.7	12.3	46.0
3.798000	32.0	Off	L1	19.7	14.0	46.0

EUT Information

Test Mode : Mode 1
 Test Voltage : 120Vac/60Hz
 Phase : Neutral

ENV216 Auto Test FCC Power Bar - N

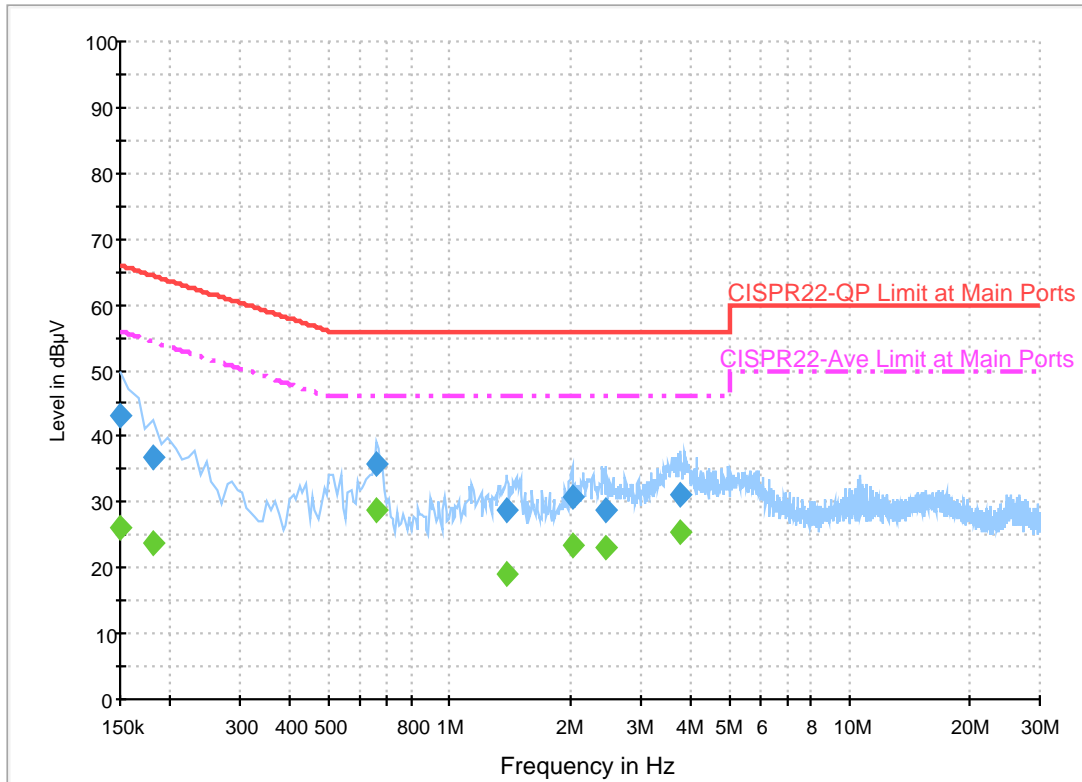

Final Result 1

Frequency (MHz)	QuasiPeak (dBµV)	Filter	Line	Corr. (dB)	Margin (dB)	Limit (dBµV)
0.150000	43.0	Off	N	19.5	23.0	66.0
0.182000	36.7	Off	N	19.5	27.7	64.4
0.654000	35.9	Off	N	19.6	20.1	56.0
1.390000	28.9	Off	N	19.6	27.1	56.0
2.030000	30.7	Off	N	19.6	25.3	56.0
2.462000	28.8	Off	N	19.2	27.2	56.0
3.774000	31.2	Off	N	19.7	24.8	56.0

Final Result 2

Frequency (MHz)	Average (dBµV)	Filter	Line	Corr. (dB)	Margin (dB)	Limit (dBµV)
0.150000	26.0	Off	N	19.5	30.0	56.0
0.182000	23.8	Off	N	19.5	30.6	54.4
0.654000	28.7	Off	N	19.6	17.3	46.0
1.390000	19.0	Off	N	19.6	27.0	46.0
2.030000	23.3	Off	N	19.6	22.7	46.0
2.462000	23.0	Off	N	19.2	23.0	46.0
3.774000	25.4	Off	N	19.7	20.6	46.0



Appendix C Radiated Spurious Emission

Test Engineer :	Alex Jheng, Bill Chang and Wilson Wu	Temperature :	24.0~24.3°C
		Relative Humidity :	50~52%

Band 1 - 5150~5250MHz

WIFI 802.11a (Band Edge @ 3m)

WIFI Ant. 1+2	Note	Frequency (MHz)	Level (dBμV/m)	Over Limit (dB)	Limit Line (dBμV/m)	Read Level (dBμV)	Antenna Factor (dB/m)	Cable Loss (dB)	Preamp Factor (dB)	Ant Pos (cm)	Table Pos (deg)	Peak Avg. (P/A)	Pol. (H/V)
802.11a CH 36 5180MHz		5146.38	56.61	-17.39	74	47.48	32.34	7.35	30.56	229	181	P	H
		5150	50.1	-3.9	54	40.97	32.34	7.35	30.56	229	181	A	H
	*	5180	113.12	-	-	103.92	32.39	7.37	30.56	229	181	P	H
	*	5180	106.12	-	-	96.92	32.39	7.37	30.56	229	181	A	H
		5338	59.05	-9.15	68.2	49.56	32.63	7.45	30.59	229	181	P	H
		5392	58.58	-15.42	74	48.99	32.71	7.48	30.6	352	166	P	H
		5392	14.18	-39.82	54	4.59	32.71	7.48	30.6	352	166	A	H
		5608	56.81	-11.39	68.2	46.91	32.88	7.68	30.66	229	181	P	H
		5149.24	52.38	-21.62	74	43.25	32.34	7.35	30.56	399	28	P	V
		5148.72	44.71	-9.29	54	35.58	32.34	7.35	30.56	399	28	A	V
	*	5180	106.29	-	-	97.09	32.39	7.37	30.56	399	28	P	V
	*	5180	99.29	-	-	90.09	32.39	7.37	30.56	399	28	A	V
802.11a CH 44 5220MHz		5066.04	56.03	-17.97	74	47.07	32.21	7.3	30.55	234	184	P	H
		5148.2	47.79	-6.21	54	38.66	32.34	7.35	30.56	234	184	A	H
	*	5220	118.26	-	-	108.99	32.45	7.39	30.57	234	184	P	H
	*	5220	110.98	-	-	101.71	32.45	7.39	30.57	234	184	A	H
		5382.72	58.16	-15.84	74	48.56	32.71	7.48	30.59	234	184	P	H
		5443.76	50.95	-3.05	54	41.24	32.79	7.52	30.6	234	184	A	H
		5064.48	52.06	-21.94	74	43.1	32.21	7.3	30.55	395	75	P	V
		5058.76	43.34	-10.66	54	34.38	32.21	7.3	30.55	395	75	A	V
	*	5220	110.76	-	-	101.49	32.45	7.39	30.57	395	75	P	V
	*	5220	103.19	-	-	93.92	32.45	7.39	30.57	395	75	A	V
		5442.92	52.65	-21.35	74	42.94	32.79	7.52	30.6	395	75	P	V
		5442.36	45.3	-8.7	54	35.59	32.79	7.52	30.6	395	75	A	V



802.11a CH 48 5240MHz		5083.2	55.18	-18.82	74	46.19	32.23	7.31	30.55	231	183	P	H
		5074.36	47.31	-6.69	54	38.32	32.23	7.31	30.55	231	183	A	H
	*	5240	118.89	-	-	109.6	32.47	7.4	30.58	231	183	P	H
	*	5240	111.55	-	-	102.26	32.47	7.4	30.58	231	183	A	H
		5464	60.29	-7.91	68.2	50.51	32.85	7.54	30.61	222	177	P	H
		5686	60.33	-7.87	68.2	50.39	32.86	7.77	30.69	212	184	P	H
		5459.44	58.54	-15.46	74	48.78	32.82	7.54	30.6	231	183	P	H
		5459.72	50.82	-3.18	54	41.06	32.82	7.54	30.6	231	183	A	H
		5082.42	51.46	-22.54	74	42.47	32.23	7.31	30.55	392	75	P	V
		5082.42	43.37	-10.63	54	34.38	32.23	7.31	30.55	392	75	A	V
	*	5240	110.64	-	-	101.35	32.47	7.4	30.58	392	75	P	V
	*	5240	103.74	-	-	94.45	32.47	7.4	30.58	392	75	A	V
		5451.32	51.69	-22.31	74	41.93	32.82	7.54	30.6	392	75	P	V
		5458.88	44.73	-9.27	54	34.97	32.82	7.54	30.6	392	75	A	V
Remark	1. No other spurious found. 2. All results are PASS against Peak and Average limit line.												



Band 1 5150~5250MHz

WIFI 802.11a (Harmonic @ 3m)

WIFI Ant.	Note	Frequency	Level	Over Limit	Limit Line	Read Level	Antenna Factor	Cable Loss	Preamp Factor	Ant Pos	Table Pos	Peak Avg.	Pol.
1+2		(MHz)	(dBμV/m)	(dB)	(dBμV/m)	(dBμV)	(dB/m)	(dB)	(dB)	(cm)	(deg)	(P/A)	(H/V)
802.11a CH 36 5180MHz		10360	53.15	-15.05	68.2	60.32	38.57	10.75	57.03	100	0	P	H
		15540	49.62	-24.38	74	53.66	38.68	13	56.48	100	0	P	H
		10360	49.71	-18.49	68.2	56.88	38.57	10.75	57.03	100	0	P	V
		15540	49.21	-24.79	74	53.25	38.68	13	56.48	100	0	P	V
802.11a CH 44 5220MHz		10440	65.17	-3.03	68.2	72.25	38.59	10.8	57.01	100	0	P	H
		15660	58.6	-15.4	74	62.95	38.24	13.07	56.41	182	245	P	H
		15660	49.12	-4.88	54	53.47	38.24	13.07	56.41	182	245	A	H
		10440	59.43	-8.77	68.2	66.51	38.59	10.8	57.01	100	0	P	V
		15660	57.68	-16.32	74	62.03	38.24	13.07	56.41	170	177	P	V
		15660	48.92	-5.08	54	53.27	38.24	13.07	56.41	170	177	A	V
802.11a CH 48 5240MHz		10480	64.01	-4.19	68.2	71.04	38.6	10.83	57	100	0	P	H
		15720	62.58	-11.42	74	67.12	37.99	13.1	56.37	177	240	P	H
		15720	50.56	-3.44	54	55.1	37.99	13.1	56.37	177	240	A	H
		10480	58.48	-9.72	68.2	65.51	38.6	10.83	57	100	0	P	V
		15720	60.79	-13.21	74	65.33	37.99	13.1	56.37	166	177	P	V
		15720	48.98	-5.02	54	53.52	37.99	13.1	56.37	166	177	A	V
Remark	1. No other spurious found. 2. All results are PASS against Peak and Average limit line.												



Band 1 5150~5250MHz
WIFI 802.11n HT20 (Band Edge @ 3m)

WIFI Ant.	Note	Frequency	Level	Over Limit	Limit Line	Read Level	Antenna Factor	Cable Loss	Preamp Factor	Ant Pos	Table Pos	Peak Avg.	Pol.
1+2		(MHz)	(dBμV/m)	(dB)	(dBμV/m)	(dBμV)	(dB/m)	(dB)	(dB)	(cm)	(deg)	(P/A)	(H/V)
802.11n HT20 CH 36 5180MHz		5148.2	56.32	-17.68	74	47.19	32.34	7.35	30.56	233	179	P	H
		5150	50.91	-3.09	54	41.78	32.34	7.35	30.56	233	179	A	H
	*	5180	111.94	-	-	102.74	32.39	7.37	30.56	233	179	P	H
	*	5180	104.4	-	-	95.2	32.39	7.37	30.56	233	179	A	H
		5344	58.1	-10.1	68.2	48.57	32.66	7.46	30.59	233	179	P	H
		5404	58.9	-15.1	74	49.27	32.74	7.49	30.6	244	174	P	H
		5404	51	-3	54	41.37	32.74	7.49	30.6	244	174	A	H
		5614	55.82	-12.38	68.2	45.91	32.88	7.7	30.67	233	179	P	H
		5144.56	51.59	-22.41	74	42.46	32.34	7.35	30.56	397	73	P	V
		5150	44.78	-9.22	54	35.65	32.34	7.35	30.56	397	73	A	V
	*	5180	104.4	-	-	95.2	32.39	7.37	30.56	397	73	P	V
	*	5180	96.91	-	-	87.71	32.39	7.37	30.56	397	73	A	V
802.11n HT20 CH 44 5220MHz		5150	54.95	-19.05	74	45.82	32.34	7.35	30.56	242	184	P	H
		5149.24	48.15	-5.85	54	39.02	32.34	7.35	30.56	242	184	A	H
	*	5220	117.11	-	-	107.84	32.45	7.39	30.57	242	184	P	H
	*	5220	109.71	-	-	100.44	32.45	7.39	30.57	242	184	A	H
		5656	57.79	-10.41	68.2	47.87	32.87	7.73	30.68	242	184	P	H
		5446	56.94	-17.06	74	47.2	32.82	7.52	30.6	242	184	P	H
		5442.92	49.93	-4.07	54	40.22	32.79	7.52	30.6	242	184	A	H
		5063.96	51.23	-22.77	74	42.27	32.21	7.3	30.55	392	76	P	V
		5068.12	42.93	-11.07	54	33.97	32.21	7.3	30.55	392	76	A	V
	*	5220	109.59	-	-	100.32	32.45	7.39	30.57	392	76	P	V
	*	5220	102.14	-	-	92.87	32.45	7.39	30.57	392	76	A	V
		5442.64	52.99	-21.01	74	43.28	32.79	7.52	30.6	392	76	P	V
	5444.88	44.4	-9.6	54	34.69	32.79	7.52	30.6	392	76	A	V	



802.11n HT20 CH 48 5240MHz		5082.42	54.03	-19.97	74	45.04	32.23	7.31	30.55	236	178	P	H
		5084.24	46.48	-7.52	54	37.49	32.23	7.31	30.55	236	178	A	H
	*	5240	118.07	-	-	108.78	32.47	7.4	30.58	236	178	P	H
	*	5240	110.32	-	-	101.03	32.47	7.4	30.58	236	178	A	H
		5464	58.79	-9.41	68.2	49.01	32.85	7.54	30.61	236	178	P	H
		5668	56.73	-11.47	68.2	46.8	32.87	7.75	30.69	236	178	P	H
		5398.12	57.16	-16.84	74	47.53	32.74	7.49	30.6	236	178	P	H
		5456.64	49.66	-4.34	54	39.9	32.82	7.54	30.6	236	178	A	H
		5073.58	51.32	-22.68	74	42.33	32.23	7.31	30.55	390	77	P	V
		5081.38	43.32	-10.68	54	34.33	32.23	7.31	30.55	390	77	A	V
	*	5240	109.47	-	-	100.18	32.47	7.4	30.58	390	77	P	V
	*	5240	102.38	-	-	93.09	32.47	7.4	30.58	390	77	A	V
		5450.76	50.4	-23.6	74	40.64	32.82	7.54	30.6	390	77	P	V
		5455.8	43.91	-10.09	54	34.15	32.82	7.54	30.6	390	77	A	V
Remark	3. No other spurious found. 4. All results are PASS against Peak and Average limit line.												



Band 1 5150~5250MHz
WIFI 802.11n HT20 (Harmonic @ 3m)

WIFI Ant.	Note	Frequency	Level	Over Limit	Limit Line	Read Level	Antenna Factor	Cable Loss	Preamp Factor	Ant Pos	Table Pos	Peak Avg.	Pol.	
1+2		(MHz)	(dBμV/m)	(dB)	(dBμV/m)	(dBμV)	(dB/m)	(dB)	(dB)	(cm)	(deg)	(P/A)	(H/V)	
802.11n HT20 CH 36		10360	52.07	-16.13	68.2	59.24	38.57	10.75	57.03	100	0	P	H	
		15540	48.75	-25.25	74	52.79	38.68	13	56.48	100	0	P	H	
5180MHz		10360	48.77	-19.43	68.2	55.94	38.57	10.75	57.03	100	0	P	V	
		15540	48.12	-25.88	74	52.16	38.68	13	56.48	100	0	P	V	
802.11n HT20 CH 44		10440	64.52	-3.68	68.2	71.6	38.59	10.8	57.01	100	0	P	H	
		15660	59.03	-14.97	74	63.38	38.24	13.07	56.41	179	246	P	H	
		15660	48.32	-5.68	54	52.67	38.24	13.07	56.41	179	246	A	H	
		10440	57	-11.2	68.2	64.08	38.59	10.8	57.01	100	0	P	V	
5220MHz		15660	58.25	-15.75	74	62.6	38.24	13.07	56.41	167	175	P	V	
		15660	47.91	-6.09	54	52.26	38.24	13.07	56.41	167	175	A	V	
802.11n HT20 CH 48		10480	66.95	-1.25	68.2	73.98	38.6	10.83	57	180	144	P	H	
		15720	59.37	-14.63	74	63.91	37.99	13.1	56.37	176	241	P	H	
		15720	51.17	-2.83	54	55.71	37.99	13.1	56.37	176	241	A	H	
		10480	60.17	-8.03	68.2	67.2	38.6	10.83	57	100	0	P	V	
	5240MHz		15720	58.8	-15.2	74	63.34	37.99	13.1	56.37	164	177	P	V
			15720	50.26	-3.74	54	54.8	37.99	13.1	56.37	164	177	A	V
Remark	1. No other spurious found. 2. All results are PASS against Peak and Average limit line.													



Band 1 5150~5250MHz
WIFI 802.11n HT40 (Band Edge @ 3m)

WIFI Ant. 1+2	Note	Frequency (MHz)	Level (dBµV/m)	Over Limit (dB)	Limit Line (dBµV/m)	Read Level (dBµV)	Antenna Factor (dB/m)	Cable Loss (dB)	Preamp Factor (dB)	Ant Pos (cm)	Table Pos (deg)	Peak Avg. (P/A)	Pol. (H/V)
802.11n HT40 CH 38 5190MHz		5145.6	58.52	-15.48	74	49.39	32.34	7.35	30.56	204	184	P	H
		5150	51.74	-2.26	54	42.61	32.34	7.35	30.56	204	184	A	H
	*	5190	104.23	-	-	95.04	32.39	7.37	30.57	204	184	P	H
	*	5190	97.42	-	-	88.23	32.39	7.37	30.57	204	184	A	H
		5362.84	52.06	-21.94	74	42.49	32.69	7.47	30.59	204	184	P	H
		5363.4	44.25	-9.75	54	34.68	32.69	7.47	30.59	204	184	A	H
		5021.58	51.11	-22.89	74	42.22	32.15	7.28	30.54	331	29	P	V
		5146.38	45.46	-8.54	54	36.33	32.34	7.35	30.56	331	29	A	V
	*	5190	95.21	-	-	86.02	32.39	7.37	30.57	331	29	P	V
	*	5190	88.4	-	-	79.21	32.39	7.37	30.57	331	29	A	V
		5385.8	49.64	-24.36	74	40.04	32.71	7.48	30.59	331	29	P	V
		5442.08	41.5	-12.5	54	31.79	32.79	7.52	30.6	331	29	A	V
	802.11n HT40 CH 46 5230MHz		5149.76	56.81	-17.19	74	47.68	32.34	7.35	30.56	242	185	P
		5150	51.08	-2.92	54	41.95	32.34	7.35	30.56	242	185	A	H
*		5230	111.79	-	-	102.5	32.47	7.39	30.57	242	185	P	H
*		5230	104.9	-	-	95.61	32.47	7.39	30.57	242	185	A	H
		5395.04	53.5	-20.5	74	43.87	32.74	7.49	30.6	242	185	P	H
		5382.16	46.93	-7.07	54	37.33	32.71	7.48	30.59	242	185	A	H
		5145.34	51.04	-22.96	74	41.91	32.34	7.35	30.56	391	75	P	V
		5149.76	44.58	-9.42	54	35.45	32.34	7.35	30.56	391	75	A	V
*		5230	104.29	-	-	95	32.47	7.39	30.57	391	75	P	V
*		5230	97.09	-	-	87.8	32.47	7.39	30.57	391	75	A	V
	5444.32	50.27	-23.73	74	40.56	32.79	7.52	30.6	391	75	P	V	
	5387.2	42.01	-11.99	54	32.41	32.71	7.48	30.59	391	75	A	V	
Remark	1. No other spurious found. 2. All results are PASS against Peak and Average limit line.												



**Band 1 5150~5250MHz
WIFI 802.11n HT40 (Harmonic @ 3m)**

WIFI Ant.	Note	Frequency	Level	Over Limit	Limit Line	Read Level	Antenna Factor	Cable Loss	Preamp Factor	Ant Pos	Table Pos	Peak Avg.	Pol.
1+2		(MHz)	(dB μ V/m)	(dB)	(dB μ V/m)	(dB μ V)	(dB/m)	(dB)	(dB)	(cm)	(deg)	(P/A)	(H/V)
802.11n		10380	46.78	-21.42	68.2	53.92	38.58	10.76	57.02	100	0	P	H
HT40		15570	46.68	-27.32	74	50.82	38.55	13.02	56.46	100	0	P	H
CH 38		10380	45.75	-22.45	68.2	52.89	38.58	10.76	57.02	100	0	P	V
5190MHz		15570	46.99	-27.01	74	51.13	38.55	13.02	56.46	100	0	P	V
802.11n		10460	59.6	-8.6	68.2	66.67	38.59	10.81	57.01	100	0	P	H
HT40		15690	49.4	-24.6	74	53.85	38.12	13.08	56.39	100	0	P	H
CH 46		10460	52.82	-15.38	68.2	59.89	38.59	10.81	57.01	100	0	P	V
5230MHz		15690	48.76	-25.24	74	53.21	38.12	13.08	56.39	100	0	P	V
Remark	1. No other spurious found. 2. All results are PASS against Peak and Average limit line.												



Band 1 5150~5250MHz
WIFI 802.11ac VHT80 (Band Edge @ 3m)

WIFI Ant. 1+2	Note	Frequency (MHz)	Level (dBμV/m)	Over Limit (dB)	Limit Line (dBμV/m)	Read Level (dBμV)	Antenna Factor (dB/m)	Cable Loss (dB)	Preamp Factor (dB)	Ant Pos (cm)	Table Pos (deg)	Peak Avg. (P/A)	Pol. (H/V)
802.11ac VHT80 CH 42 5210MHz		5140.4	56.17	-17.83	74	47.05	32.34	7.34	30.56	228	184	P	H
		5145.6	52.18	-1.82	54	43.05	32.34	7.35	30.56	228	184	A	H
	*	5210	101.14	-	-	91.88	32.45	7.38	30.57	228	184	P	H
	*	5210	94.79	-	-	85.53	32.45	7.38	30.57	228	184	A	H
		5358.36	50.28	-23.72	74	40.74	32.66	7.47	30.59	228	184	P	H
		5354.44	44.11	-9.89	54	34.58	32.66	7.46	30.59	228	184	A	H
		5116.48	50.89	-23.11	74	41.83	32.29	7.33	30.56	393	74	P	V
		5147.42	44.83	-9.17	54	35.7	32.34	7.35	30.56	393	74	A	V
	*	5210	93.98	-	-	84.72	32.45	7.38	30.57	393	74	P	V
	*	5210	87.19	-	-	77.93	32.45	7.38	30.57	393	74	A	V
		5437.6	48.8	-25.2	74	39.09	32.79	7.52	30.6	393	74	P	V
	5350.52	42.97	-11.03	54	33.44	32.66	7.46	30.59	393	74	A	V	
Remark	1. No other spurious found. 2. All results are PASS against Peak and Average limit line.												



Band 1 5150~5250MHz

WIFI 802.11ac VHT80 (Harmonic @ 3m)

WIFI Ant.	Note	Frequency	Level	Over Limit	Limit Line	Read Level	Antenna Factor	Cable Loss	Preamp Factor	Ant Pos	Table Pos	Peak Avg.	Pol.
1+2		(MHz)	(dBμV/m)	(dB)	(dBμV/m)	(dBμV)	(dB/m)	(dB)	(dB)	(cm)	(deg)	(P/A)	(H/V)
802.11ac		10420	47.02	-21.18	68.2	54.13	38.58	10.79	57.02	100	0	P	H
VHT80		15630	46.78	-27.22	74	51.1	38.3	13.05	56.42	100	0	P	H
CH 42		10420	48.3	-19.9	68.2	55.41	38.58	10.79	57.02	100	0	P	V
5210MHz		15630	47.13	-26.87	74	51.45	38.3	13.05	56.42	100	0	P	V
Remark	1. No other spurious found. 2. All results are PASS against Peak and Average limit line.												



Emission below 1GHz

WIFI 802.11ac VHT80 (LF @ 3m)

WIFI Ant. 1+2	Note	Frequency (MHz)	Level (dBμV/m)	Over Limit (dB)	Limit Line (dBμV/m)	Read Level (dBμV)	Antenna Factor (dB/m)	Cable Loss (dB)	Preamp Factor (dB)	Ant Pos (cm)	Table Pos (deg)	Peak Avg. (P/A)	Pol. (H/V)
802.11n HT40 LF		93.99	33.54	-9.96	43.5	54.05	10.66	1	32.29	-	-	93.99	H
		133.95	32.29	-11.21	43.5	49.56	13.77	1.19	32.28	-	-	133.95	H
		283.26	32.59	-13.41	46	47.53	15.46	1.68	32.15	-	-	283.26	H
		660.5	42.85	-3.15	46	49.07	23.34	2.51	32.19	100	0	660.5	H
		706.7	42.47	-3.53	46	48.03	23.86	2.64	32.16	-	-	706.7	H
		758.5	40.85	-5.15	46	44.92	25.19	2.71	32.07	-	-	758.5	H
		78.6	32.16	-7.84	40	52.99	10.43	0.95	32.3	-	-	78.6	V
		108.03	31.13	-12.37	43.5	47.98	14.33	1	32.29	-	-	108.03	V
		281.64	28.91	-17.09	46	43.88	15.44	1.68	32.16	-	-	281.64	V
		538	36.28	-9.72	46	44.73	21.36	2.29	32.2	-	-	538	V
		650	36.72	-9.28	46	42.86	23.42	2.51	32.19	-	-	650	V
		708.8	39.77	-6.23	46	45.24	23.94	2.64	32.15	100	0	708.8	V
Remark	1. No other spurious found. 2. All results are PASS against limit line.												



Note symbol

*	Fundamental Frequency which can be ignored. However, the level of any unwanted emissions shall not exceed the level of the fundamental frequency.
!	Test result is over limit line.
P/A	Peak or Average
H/V	Horizontal or Vertical



A calculation example for radiated spurious emission is shown as below:

WIFI	Note	Frequency	Level	Over	Limit	Read	Antenna	Cable	Preamp	Ant	Table	Peak	Pol.
Ant.				Limit	Line	Level	Factor	Loss	Factor	Pos	Pos	Avg.	
1+2		(MHz)	(dBμV/m)	(dB)	(dBμV/m)	(dBμV)	(dB/m)	(dB)	(dB)	(cm)	(deg)	(P/A)	(H/V)
802.11b		2390	55.45	-18.55	74	54.51	32.22	4.58	35.86	103	308	P	H
CH 01													
2412MHz		2390	43.54	-10.46	54	42.6	32.22	4.58	35.86	103	308	A	H

- 1. Level(dBμV/m) =
Antenna Factor(dB/m) + Cable Loss(dB) + Read Level(dBμV) - Preamp Factor(dB)
- 2. Over Limit(dB) = Level(dBμV/m) – Limit Line(dBμV/m)

For Peak Limit @ 2390MHz:

- 1. Level(dBμV/m)
= Antenna Factor(dB/m) + Cable Loss(dB) + Read Level(dBμV) - Preamp Factor(dB)
= 32.22(dB/m) + 4.58(dB) + 54.51(dBμV) – 35.86 (dB)
= 55.45 (dBμV/m)
- 2. Over Limit(dB)
= Level(dBμV/m) – Limit Line(dBμV/m)
= 55.45(dBμV/m) – 74(dBμV/m)
= -18.55(dB)

For Average Limit @ 2390MHz:

- 1. Level(dBμV/m)
= Antenna Factor(dB/m) + Cable Loss(dB) + Read Level(dBμV) - Preamp Factor(dB)
= 32.22(dB/m) + 4.58(dB) + 42.6(dBμV) – 35.86 (dB)
= 43.54 (dBμV/m)
- 2. Over Limit(dB)
= Level(dBμV/m) – Limit Line(dBμV/m)
= 43.54(dBμV/m) – 54(dBμV/m)
= -10.46(dB)

Both peak and average measured complies with the limit line, so test result is “PASS”.



Appendix D. Radiated Spurious Emission

Test Engineer :	Alex Jheng, Bill Chang and Wilson Wu	Temperature :	24.0~24.3°C
		Relative Humidity :	50~52%

Band 1 - 5150~5250MHz
WIFI 802.11a (Band Edge @ 3m)

WIFI	Band 1 5150~5250MHz Band Edge @ 3m	
ANT	802.11a CH36 5180MHz	
1+2	Horizontal	Fundamental
Peak	<p>Site : 03CH13-HY Condition : PEAK_BE_74 3m HORN_91200_1522 HORIZONTAL Detector : RBW:1000.000KHz VBW:3000.000KHz SWT:Auto Peak</p>	<p>Site : 03CH13-HY Condition : PEAK(UNIT) 3m HORN_91200_1522 HORIZONTAL Detector : RBW:1000.000KHz VBW:3000.000KHz SWT:Auto Peak</p>

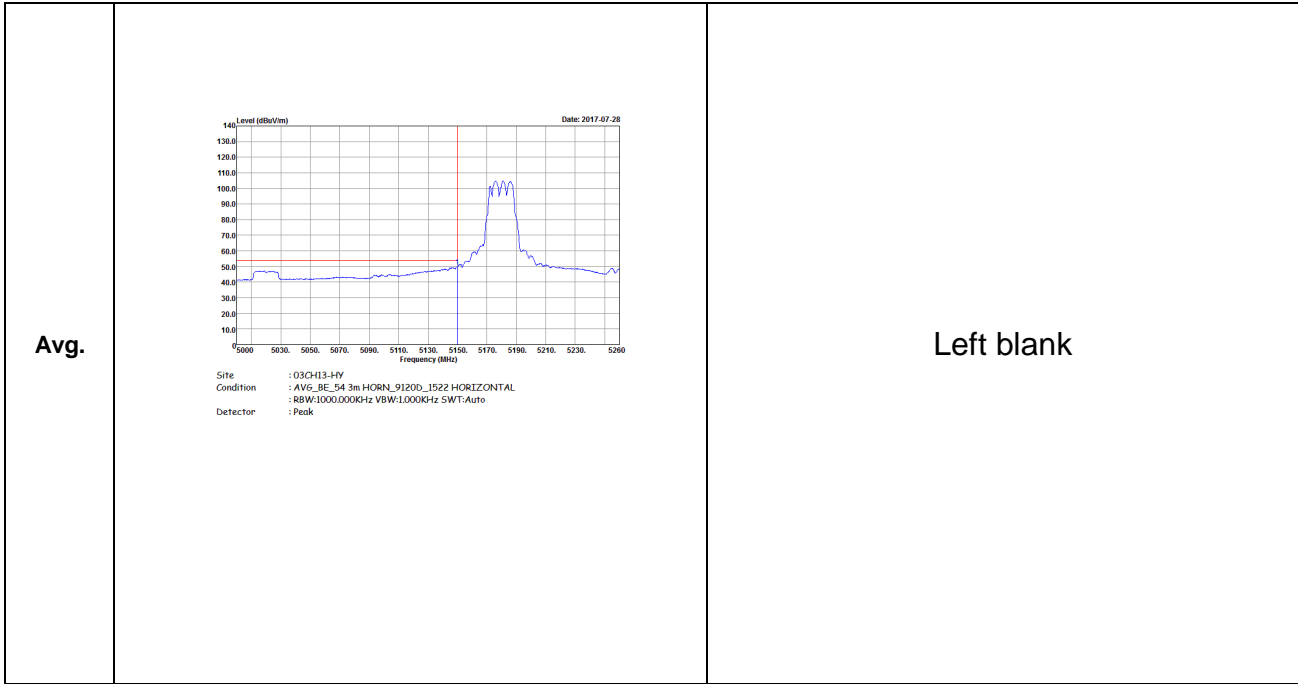

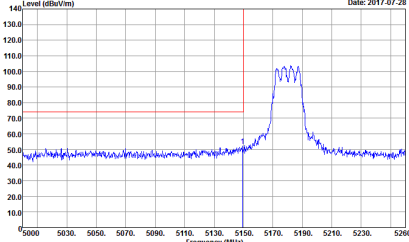
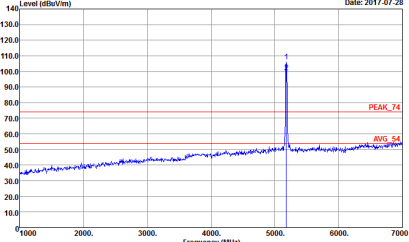
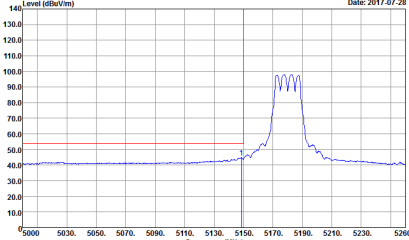

WIFI	Band 1 5150~5250MHz Band Edge @ 3m	
ANT	802.11a CH36 5180MHz	
1+2	Vertical	Fundamental
Peak	 <p>Level (dBuV/m) vs Frequency (MHz) plot for Peak Vertical. The plot shows a signal peak at approximately 5180 MHz. The y-axis ranges from 10.0 to 140.0 dBuV/m, and the x-axis ranges from 5000 to 5260 MHz. A red vertical line is drawn at 5180 MHz. The date is 2017-07-28.</p> <p>Site : 03CH13-HY Condition : PEAK_BE_74 3m HORN_91200_1522 VERTICAL RBW:1000.000KHz VBW:3000.000KHz SWT:Auto Detector : Peak</p>	 <p>Level (dBuV/m) vs Frequency (MHz) plot for Peak Fundamental. The plot shows a signal peak at approximately 5180 MHz. The y-axis ranges from 10.0 to 140.0 dBuV/m, and the x-axis ranges from 1000 to 7000 MHz. A red vertical line is drawn at 5180 MHz. The date is 2017-07-28.</p> <p>Site : 03CH13-HY Condition : PEAK_74 3m HORN_91200_1522 VERTICAL RBW:1000.000KHz VBW:3000.000KHz SWT:Auto Detector : Peak</p>
Avg.	 <p>Level (dBuV/m) vs Frequency (MHz) plot for Avg Vertical. The plot shows a signal peak at approximately 5180 MHz. The y-axis ranges from 10.0 to 140.0 dBuV/m, and the x-axis ranges from 5000 to 5260 MHz. A red vertical line is drawn at 5180 MHz. The date is 2017-07-28.</p> <p>Site : 03CH13-HY Condition : AVG_BE_54 3m HORN_91200_1522 VERTICAL RBW:1000.000KHz VBW:1.000KHz SWT:Auto Detector : Peak</p>	Left blank

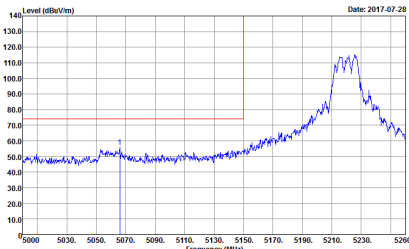
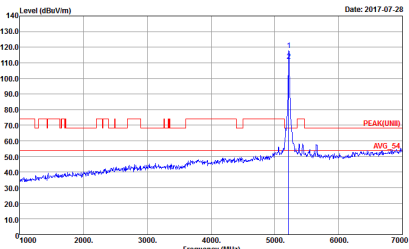
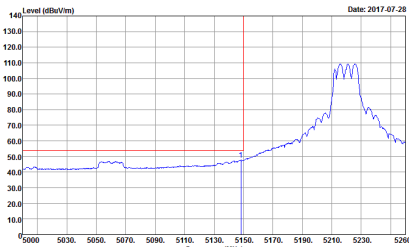

WIFI	Band 1 5150~5250MHz Band Edge @ 3m	
ANT	802.11a CH44 5220MHz - L	
1+2	Horizontal	Fundamental
Peak	 <p>Date: 2017-07-28</p> <p>Site : 03CH13-HY Condition : PEAK_BE_74 3m HORN_91200_1522 HORIZONTAL RBW:1000.000KHz VBW:3000.000KHz SWT:Auto Detector : Peak</p>	 <p>Date: 2017-07-28</p> <p>Site : 03CH13-HY Condition : PEAK(UNIT) 3m HORN_91200_1522 HORIZONTAL RBW:1000.000KHz VBW:3000.000KHz SWT:Auto Detector : Peak</p>
Avg.	 <p>Date: 2017-07-28</p> <p>Site : 03CH13-HY Condition : AVG_BE_54 3m HORN_91200_1522 HORIZONTAL RBW:1000.000KHz VBW:1.000KHz SWT:Auto Detector : Peak</p>	Left blank



WIFI	Band 1 5150~5250MHz Band Edge @ 3m	
ANT	802.11a CH44 5220MHz - R	
1+2	Horizontal	Fundamental
<p>Peak</p>	<p>Date: 2017-07-28</p> <p>PEAK_BE_74</p> <p>Site : 03CH13-HY Condition : PEAK_BE_74 3m HORN_91200_1522 HORIZONTAL RBW:1000.000KHz VBW:3000.000KHz SWT:Auto Detector : Peak</p>	<p>Left blank</p>
<p>Avg.</p>	<p>Date: 2017-07-28</p> <p>AVG_BE_54</p> <p>Site : 03CH13-HY Condition : AVG_BE_54 3m HORN_91200_1522 HORIZONTAL RBW:1000.000KHz VBW:1.000KHz SWT:Auto Detector : Peak</p>	<p>Left blank</p>

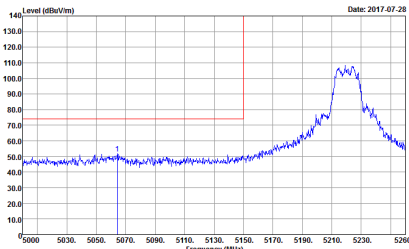
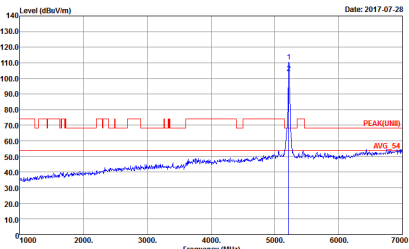
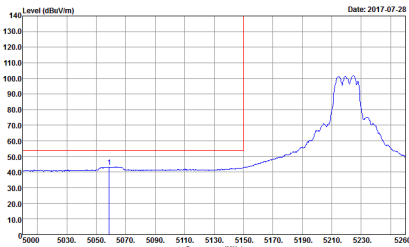

WIFI	Band 1 5150~5250MHz Band Edge @ 3m	
ANT	802.11a CH44 5220MHz - L	
1+2	Vertical	Fundamental
Peak	 <p>Date: 2017-07-28</p> <p>Site : 03CH13-HY Condition : PEAK_BE_74 3m HORN_91200_1522 VERTICAL RBW:1000.000KHz VBW:3000.000KHz SWT:Auto Detector : Peak</p>	 <p>Date: 2017-07-28</p> <p>Site : 03CH13-HY Condition : PEAK(UNIT) 3m HORN_91200_1522 VERTICAL RBW:1000.000KHz VBW:3000.000KHz SWT:Auto Detector : Peak</p>
Avg.	 <p>Date: 2017-07-28</p> <p>Site : 03CH13-HY Condition : AVG_BE_54 3m HORN_91200_1522 VERTICAL RBW:1000.000KHz VBW:1.000KHz SWT:Auto Detector : Peak</p>	Left blank

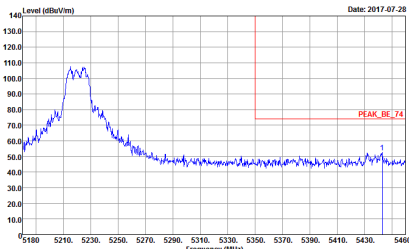
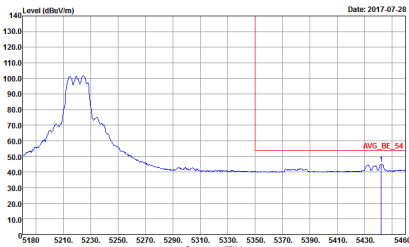

WIFI	Band 1 5150~5250MHz Band Edge @ 3m	
ANT	802.11a CH44 5220MHz - R	
1+2	Vertical	Fundamental
Peak	 <p>Site : 03CH13-HY Condition : PEAK_BE_74 3m HORN_91200_1522 VERTICAL Detector : Peak</p>	Left blank
Avg.	 <p>Site : 03CH13-HY Condition : AVG_BE_54 3m HORN_91200_1522 VERTICAL Detector : Peak</p>	Left blank

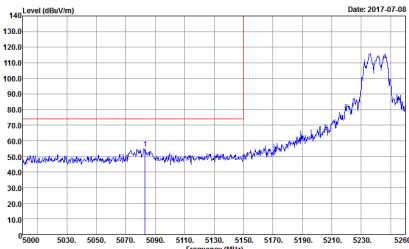
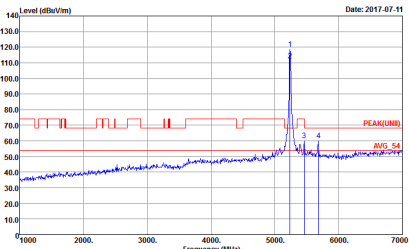
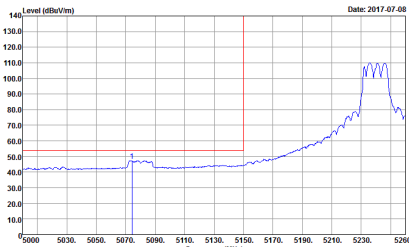

WIFI	Band 1 5150~5250MHz Band Edge @ 3m	
ANT	802.11a CH48 5240MHz - L	
1+2	Horizontal	Fundamental
Peak	 <p>Level (dBuV/m) vs Frequency (MHz) plot for Peak Horizontal. The plot shows a rising signal level from 50 dBuV/m at 5150 MHz to approximately 110 dBuV/m at 5240 MHz. A red vertical line is at 5150 MHz. A blue peak is marked at 5240 MHz.</p> <p>Date: 2017-07-08</p> <p>Site : 03CH13-HY Condition : PEAK_BE_74 3m HORN_91200_1522 HORIZONTAL RBW:1000.000KHz VBW:3000.000KHz SWT:Auto Detector : Peak</p>	 <p>Level (dBuV/m) vs Frequency (MHz) plot for Peak Fundamental. The plot shows a sharp peak at 5240 MHz reaching approximately 110 dBuV/m. A red horizontal line is at 70 dBuV/m. A blue peak is marked at 5240 MHz.</p> <p>Date: 2017-07-11</p> <p>Site : 03CH13-HY Condition : PEAK(UNIT) 3m HORN_91200_1522 HORIZONTAL RBW:1000.000KHz VBW:3000.000KHz SWT:Auto Detector : Peak</p>
Avg.	 <p>Level (dBuV/m) vs Frequency (MHz) plot for Avg Horizontal. The plot shows a rising signal level from 50 dBuV/m at 5150 MHz to approximately 110 dBuV/m at 5240 MHz. A red vertical line is at 5150 MHz. A blue peak is marked at 5240 MHz.</p> <p>Date: 2017-07-08</p> <p>Site : 03CH13-HY Condition : AVG_BE_54 3m HORN_91200_1522 HORIZONTAL RBW:1000.000KHz VBW:1.000KHz SWT:Auto Detector : Peak</p>	Left blank

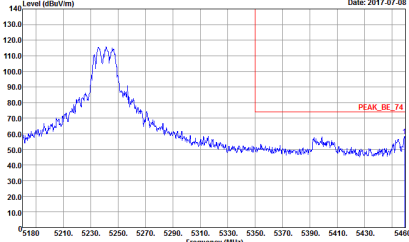
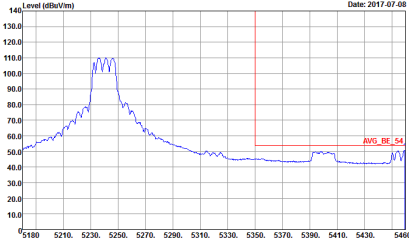

WIFI	Band 1 5150~5250MHz Band Edge @ 3m	
ANT	802.11a CH48 5240MHz - R	
1+2	Horizontal	Fundamental
<p>Peak</p>	 <p>Site : 03CH13-HY Condition : PEAK_BE_74 3m HORN_91200_1522 HORIZONTAL : RBW:1000.000KHz VBW:3000.000KHz SWT:Auto Detector : Peak</p>	<p>Left blank</p>
<p>Avg.</p>	 <p>Site : 03CH13-HY Condition : AVG_BE_54 3m HORN_91200_1522 HORIZONTAL : RBW:1000.000KHz VBW:1.000KHz SWT:Auto Detector : Peak</p>	<p>Left blank</p>

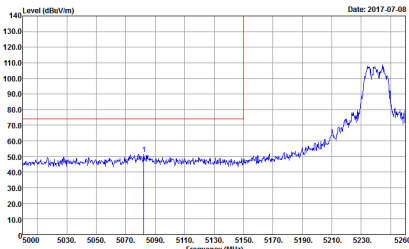
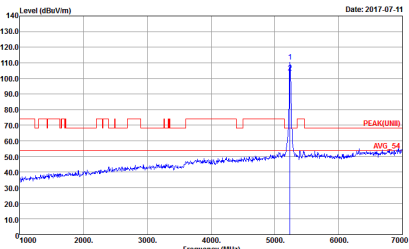
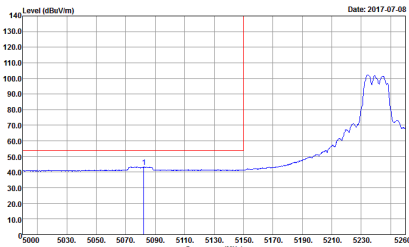

WIFI	Band 1 5150~5250MHz Band Edge @ 3m	
ANT	802.11a CH48 5240MHz - L	
1+2	Vertical	Fundamental
Peak	 <p>Date: 2017-07-08</p> <p>Site : 03CH13-HY Condition : PEAK_BE_74 3m HORN_91200_1522 VERTICAL RBW:1000.000KHz VBW:3000.000KHz SWT:Auto Detector : Peak</p>	 <p>Date: 2017-07-11</p> <p>Site : 03CH13-HY Condition : PEAK(UNIT) 3m HORN_91200_1522 VERTICAL RBW:1000.000KHz VBW:3000.000KHz SWT:Auto Detector : Peak</p>
Avg.	 <p>Date: 2017-07-08</p> <p>Site : 03CH13-HY Condition : AVG_BE_54 3m HORN_91200_1522 VERTICAL RBW:1000.000KHz VBW:1.000KHz SWT:Auto Detector : Peak</p>	Left blank



WIFI	Band 1 5150~5250MHz Band Edge @ 3m	
ANT	802.11a CH48 5240MHz - R	
1+2	Vertical	Fundamental
<p>Peak</p>	<p>Site : 03CH13-HY Condition : PEAK_BE_74 3m HORN_91200_1522 VERTICAL RBW:1000.000KHz VBW:3000.000KHz SWT:Auto Detector : Peak</p>	<p>Left blank</p>
<p>Avg.</p>	<p>Site : 03CH13-HY Condition : AVG_BE_54 3m HORN_91200_1522 VERTICAL RBW:1000.000KHz VBW:1.000KHz SWT:Auto Detector : Peak</p>	<p>Left blank</p>

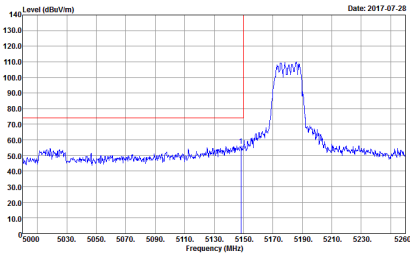
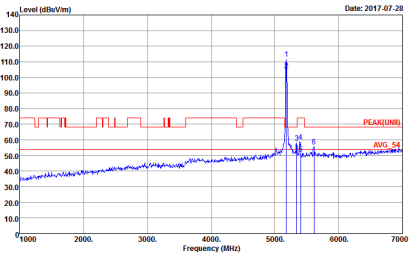
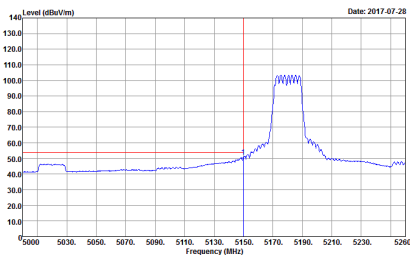

Band 1 5150~5250MHz
WIFI 802.11n HT20 (Band Edge @ 3m)

WIFI	Band 1 5150~5250MHz Band Edge @ 3m	
ANT	802.11n HT20 CH36 5180MHz	
1+2	Horizontal	Fundamental
<p>Peak</p>	 <p>Level (dBuV/m) vs Frequency (MHz) plot showing a peak at 5180 MHz. The y-axis ranges from 10.0 to 140.0 dBuV/m, and the x-axis ranges from 5000 to 5260 MHz. A red vertical line marks the peak at 5180 MHz. The plot shows a blue signal line with a sharp peak at 5180 MHz. Below the plot, the following text is present: Date: 2017-07-28 Site : 03CH13-HY Condition : PEAK_BE_74 3m HORN_9120D_1522 HORIZONTAL RBW:1000.000KHz VBW:3000.000KHz SWT:Auto Detector : Peak</p>	 <p>Level (dBuV/m) vs Frequency (MHz) plot showing a peak at 5180 MHz. The y-axis ranges from 10.0 to 140.0 dBuV/m, and the x-axis ranges from 1000 to 7000 MHz. A red vertical line marks the peak at 5180 MHz. The plot shows a blue signal line with a sharp peak at 5180 MHz. Below the plot, the following text is present: Date: 2017-07-28 Site : 03CH13-HY Condition : PEAK(UNB) 3m HORN_9120D_1522 HORIZONTAL RBW:1000.000KHz VBW:3000.000KHz SWT:Auto Detector : Peak</p>
<p>Avg.</p>	 <p>Level (dBuV/m) vs Frequency (MHz) plot showing a peak at 5180 MHz. The y-axis ranges from 10.0 to 140.0 dBuV/m, and the x-axis ranges from 5000 to 5260 MHz. A red vertical line marks the peak at 5180 MHz. The plot shows a blue signal line with a sharp peak at 5180 MHz. Below the plot, the following text is present: Date: 2017-07-28 Site : 03CH13-HY Condition : AVG_BE_54 3m HORN_9120D_1522 HORIZONTAL RBW:1000.000KHz VBW:1000KHz SWT:Auto Detector : Peak</p>	<p>Left blank</p>

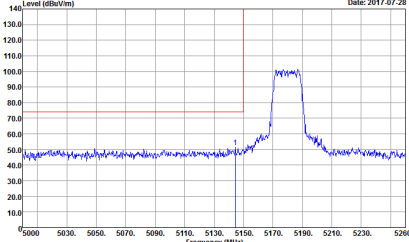
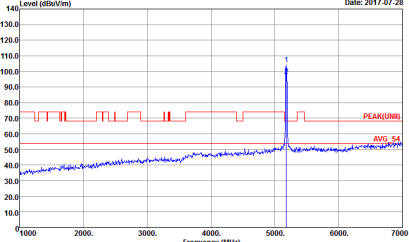
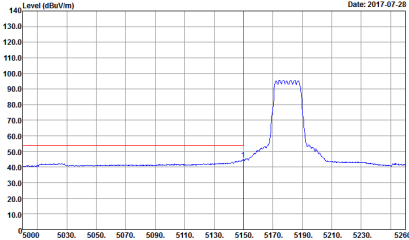

WIFI	Band 1 5150~5250MHz Band Edge @ 3m	
ANT	802.11n HT20 CH36 5180MHz	
1+2	Vertical	Fundamental
Peak	 <p>Level (dBuV/m) vs Frequency (MHz) plot showing a peak at 5180 MHz. The y-axis ranges from 10.0 to 140.0 dBuV/m, and the x-axis ranges from 5000 to 5260 MHz. A red vertical line marks the peak at 5180 MHz. The plot shows a sharp peak at 5180 MHz with a level of approximately 100 dBuV/m. The background noise is around 50 dBuV/m.</p> <p>Date: 2017-07-28</p> <p>Site : 03CH13-HY Condition : PEAK_BE_74 3m HORN_91200_1522 VERTICAL RBW:1000.000KHz VBW:3000.000KHz SWT:Auto Detector : Peak</p>	 <p>Level (dBuV/m) vs Frequency (MHz) plot showing a peak at 5180 MHz. The y-axis ranges from 10.0 to 140.0 dBuV/m, and the x-axis ranges from 1000 to 7000 MHz. A red vertical line marks the peak at 5180 MHz. The plot shows a sharp peak at 5180 MHz with a level of approximately 100 dBuV/m. The background noise is around 50 dBuV/m.</p> <p>Date: 2017-07-28</p> <p>Site : 03CH13-HY Condition : PEAK(UNIT) 3m HORN_91200_1522 VERTICAL RBW:1000.000KHz VBW:3000.000KHz SWT:Auto Detector : Peak</p>
Avg.	 <p>Level (dBuV/m) vs Frequency (MHz) plot showing an average spectrum. The y-axis ranges from 10.0 to 140.0 dBuV/m, and the x-axis ranges from 5000 to 5260 MHz. A red vertical line marks the peak at 5180 MHz. The plot shows a sharp peak at 5180 MHz with a level of approximately 100 dBuV/m. The background noise is around 50 dBuV/m.</p> <p>Date: 2017-07-28</p> <p>Site : 03CH13-HY Condition : AVG_BE_54 3m HORN_91200_1522 VERTICAL RBW:1000.000KHz VBW:1.000KHz SWT:Auto Detector : Peak</p>	Left blank

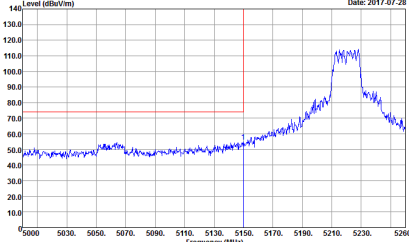
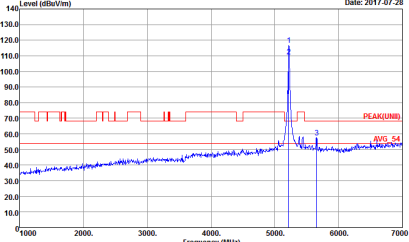
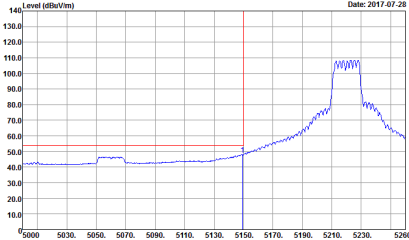

WIFI	Band 1 5150~5250MHz Band Edge @ 3m	
ANT	802.11n HT20 CH44 5220MHz - L	
1+2	Horizontal	Fundamental
Peak	 <p>Site : 03CH13-HY Condition : PEAK_BE_74 3m HORN_91200_1522 HORIZONTAL RBW:1000.000KHz VBW:3000.000KHz SWT:Auto Detector : Peak</p>	 <p>Site : 03CH13-HY Condition : PEAK(UNIT) 3m HORN_91200_1522 HORIZONTAL RBW:1000.000KHz VBW:3000.000KHz SWT:Auto Detector : Peak</p>
Avg.	 <p>Site : 03CH13-HY Condition : AVG_BE_54 3m HORN_91200_1522 HORIZONTAL RBW:1000.000KHz VBW:1.000KHz SWT:Auto Detector : Peak</p>	Left blank

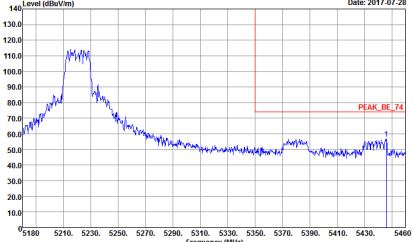
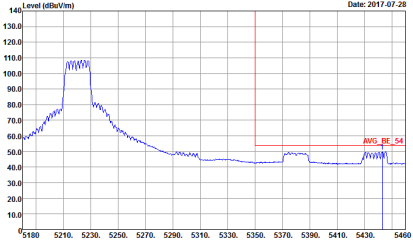

WIFI	Band 1 5150~5250MHz Band Edge @ 3m	
ANT	802.11n HT20 CH44 5220MHz - R	
1+2	Horizontal	Fundamental
Peak	 <p>Site : 03CH13-HY Condition : PEAK_BE_74 3m HORN_91200_1522 HORIZONTAL RBW:1000.000KHz VBW:3000.000KHz SWT:Auto Detector : Peak</p>	Left blank
Avg.	 <p>Site : 03CH13-HY Condition : AVG_BE_54 3m HORN_91200_1522 HORIZONTAL RBW:1000.000KHz VBW:1.000KHz SWT:Auto Detector : Peak</p>	Left blank

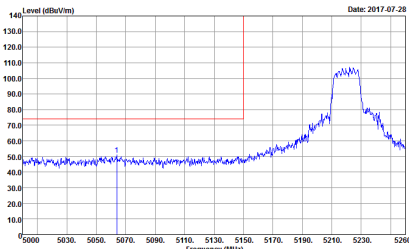
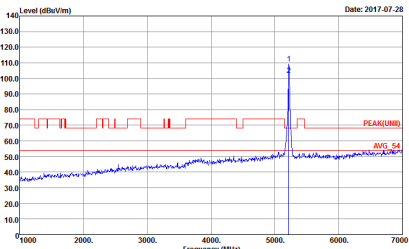
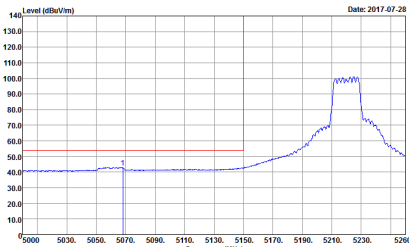

WIFI	Band 1 5150~5250MHz Band Edge @ 3m	
ANT	802.11n HT20 CH44 5220MHz - L	
1+2	Vertical	Fundamental
Peak	 <p>Date: 2017-07-28</p> <p>Site : 03CH13-HY Condition : PEAK_BE_74 3m HORN_91200_1522 VERTICAL Detector : RBW:1000.000KHz VBW:3000.000KHz SWT:Auto Detector : Peak</p>	 <p>Date: 2017-07-28</p> <p>Site : 03CH13-HY Condition : PEAK(UNIT) 3m HORN_91200_1522 VERTICAL Detector : RBW:1000.000KHz VBW:3000.000KHz SWT:Auto Detector : Peak</p>
Avg.	 <p>Date: 2017-07-28</p> <p>Site : 03CH13-HY Condition : AVG_BE_54 3m HORN_91200_1522 VERTICAL Detector : RBW:1000.000KHz VBW:1.000KHz SWT:Auto Detector : Peak</p>	Left blank

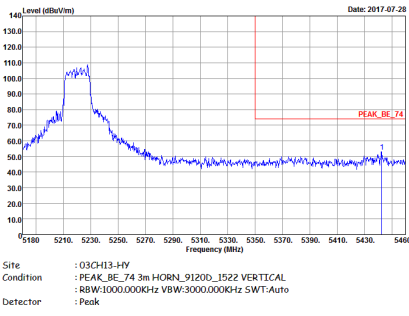
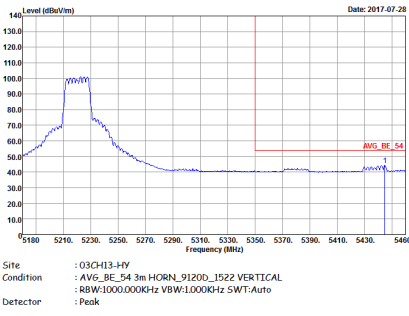

WIFI	Band 1 5150~5250MHz Band Edge @ 3m	
ANT	802.11n HT20 CH44 5220MHz - R	
1+2	Vertical	Fundamental
Peak		Left blank
Avg.		Left blank

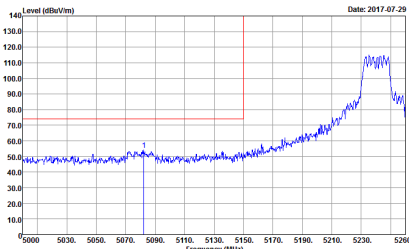
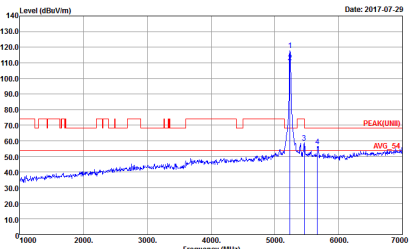
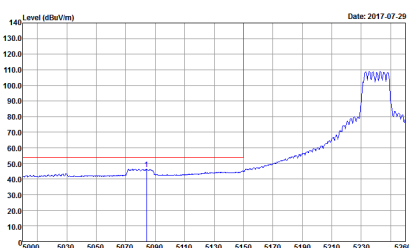

WIFI	Band 1 5150~5250MHz Band Edge @ 3m	
ANT	802.11n HT20 CH48 5240MHz - L	
1+2	Horizontal	Fundamental
Peak	 <p>Level (dBuV/m) vs Frequency (MHz) plot showing a peak at approximately 5240 MHz. The y-axis ranges from 10.0 to 140.0 dBuV/m, and the x-axis ranges from 5000 to 5260 MHz. A red vertical line is at 5150 MHz. A red horizontal line is at approximately 75 dBuV/m. A blue peak is visible at 5240 MHz.</p> <p>Date: 2017-07-29</p> <p>Site : 03CH13-HY Condition : PEAK_BE_74 3m HORN_91200_1522 HORIZONTAL RBW:1000.000KHz VBW:3000.000KHz SWT:Auto Detector : Peak</p>	 <p>Level (dBuV/m) vs Frequency (MHz) plot showing a peak at approximately 5240 MHz. The y-axis ranges from 10.0 to 140.0 dBuV/m, and the x-axis ranges from 1000 to 7000 MHz. A red horizontal line is at approximately 75 dBuV/m. A blue peak is visible at 5240 MHz.</p> <p>Date: 2017-07-29</p> <p>Site : 03CH13-HY Condition : PEAK(UNIT) 3m HORN_91200_1522 HORIZONTAL RBW:1000.000KHz VBW:3000.000KHz SWT:Auto Detector : Peak</p>
Avg.	 <p>Level (dBuV/m) vs Frequency (MHz) plot showing a peak at approximately 5240 MHz. The y-axis ranges from 10.0 to 140.0 dBuV/m, and the x-axis ranges from 5000 to 5260 MHz. A red vertical line is at 5150 MHz. A red horizontal line is at approximately 75 dBuV/m. A blue peak is visible at 5240 MHz.</p> <p>Date: 2017-07-29</p> <p>Site : 03CH13-HY Condition : AVG_BE_54 3m HORN_91200_1522 HORIZONTAL RBW:1000.000KHz VBW:1.000KHz SWT:Auto Detector : Peak</p>	Left blank

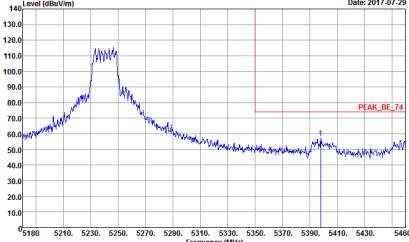
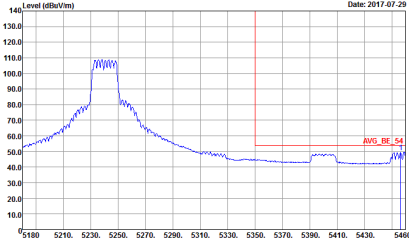

WIFI	Band 1 5150~5250MHz Band Edge @ 3m	
ANT	802.11n HT20 CH48 5240MHz - R	
1+2	Horizontal	Fundamental
Peak	 <p>Date: 2017-07-29</p> <p>Site : 03CH13-HY Condition : PEAK_BE_74 3m HORN_91200_1522 HORIZONTAL RBW:1000.000KHz VBW:3000.000KHz SWT:Auto Detector : Peak</p>	Left blank
Avg.	 <p>Date: 2017-07-29</p> <p>Site : 03CH13-HY Condition : AVG_BE_54 3m HORN_91200_1522 HORIZONTAL RBW:1000.000KHz VBW:1.000KHz SWT:Auto Detector : Peak</p>	Left blank



WIFI	Band 1 5150~5250MHz Band Edge @ 3m	
ANT	802.11n HT20 CH48 5240MHz - L	
1+2	Vertical	Fundamental
Peak	<p>Site : 03CH13-HY Condition : PEAK_BE_74 3m HORN_91200_1522 VERTICAL Detector : Peak</p>	<p>Site : 03CH13-HY Condition : PEAK(UNIT) 3m HORN_91200_1522 VERTICAL Detector : Peak</p>
Avg.	<p>Site : 03CH13-HY Condition : AVG_BE_54 3m HORN_91200_1522 VERTICAL Detector : Peak</p>	Left blank

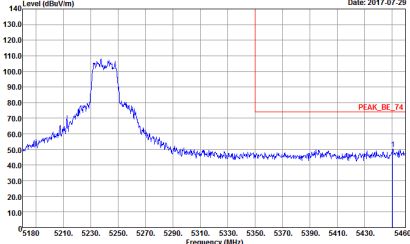
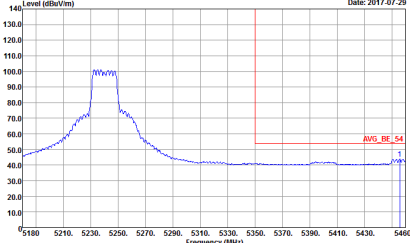

WIFI	Band 1 5150~5250MHz Band Edge @ 3m	
ANT	802.11n HT20 CH48 5240MHz - R	
1+2	Vertical	Fundamental
Peak	 <p>Site : 03CH13-HY Condition : PEAK_BE_74 3m HORN_91200_1522 VERTICAL RBW:1000.000KHz VBW:3000.000KHz SWT:Auto Detector : Peak</p>	Left blank
Avg.	 <p>Site : 03CH13-HY Condition : AVG_BE_54 3m HORN_91200_1522 VERTICAL RBW:1000.000KHz VBW:1.000KHz SWT:Auto Detector : Peak</p>	Left blank

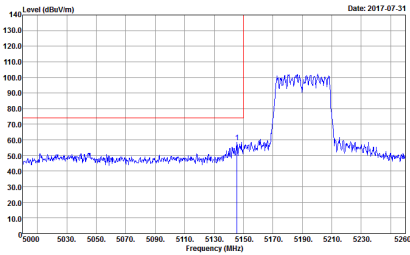
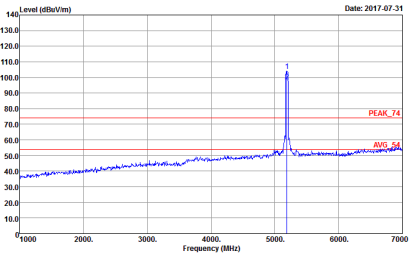
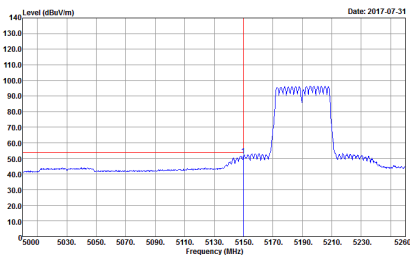

Band 1 5150~5250MHz
WIFI 802.11n HT40 (Band Edge @ 3m)

WIFI	Band 1 5150~5250MHz Band Edge @ 3m	
ANT	802.11n HT40 CH38 5190MHz - L	
1+2	Horizontal	Fundamental
Peak	 <p>Site : 03CH13-HY Condition : PEAK_BE_74 3m HORN_9120D_1522 HORIZONTAL RBW:1000.000KHz VBW:3000.000KHz SWT:Auto Detector : Peak</p>	 <p>Site : 03CH13-HY Condition : PEAK_74 3m HORN_9120D_1522 HORIZONTAL RBW:1000.000KHz VBW:3000.000KHz SWT:Auto Detector : Peak</p>
Avg.	 <p>Site : 03CH13-HY Condition : AVG_BE_54 3m HORN_9120D_1522 HORIZONTAL RBW:1000.000KHz VBW:3000.000KHz SWT:Auto Detector : Peak</p>	Left blank

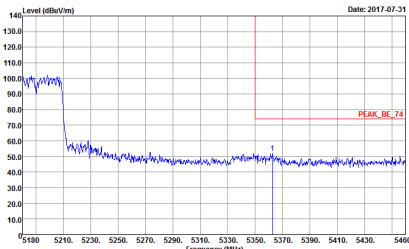
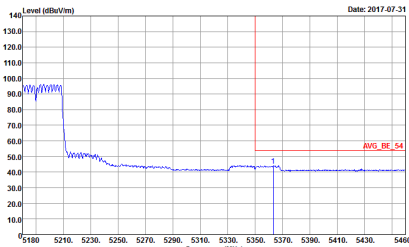

WIFI	Band 1 5150~5250MHz Band Edge @ 3m	
ANT	802.11n HT40 CH38 5190MHz - R	
1+2	Horizontal	Fundamental
Peak	 <p>Date: 2017-07-31</p> <p>Site : 03CH13-HY Condition : PEAK_BE_74 3m HORN_91200_1522 HORIZONTAL RBW:1000.000KHz VBW:3000.000KHz SWT:Auto Detector : Peak</p>	Left blank
Avg.	 <p>Date: 2017-07-31</p> <p>Site : 03CH13-HY Condition : AVG_BE_54 3m HORN_91200_1522 HORIZONTAL RBW:1000.000KHz VBW:3.000KHz SWT:Auto Detector : Peak</p>	Left blank

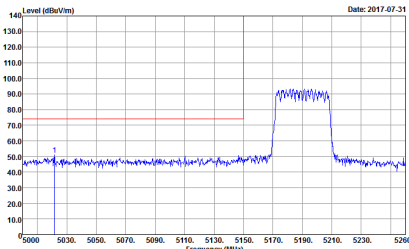
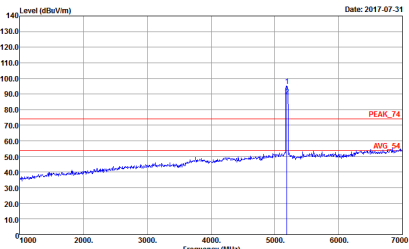
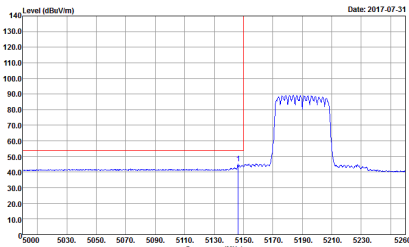

WIFI	Band 1 5150~5250MHz Band Edge @ 3m	
ANT	802.11n HT40 CH38 5190MHz - L	
1+2	Vertical	Fundamental
Peak	 <p>Date: 2017-07-31</p> <p>Site : 03CH13-HY Condition : PEAK_BE_74 3m HORN_91200_1522 VERTICAL RBW:1000.000KHz VBW:3000.000KHz SWT:Auto Detector : Peak</p>	 <p>Date: 2017-07-31</p> <p>Site : 03CH13-HY Condition : PEAK_74 3m HORN_91200_1522 VERTICAL RBW:1000.000KHz VBW:3000.000KHz SWT:Auto Detector : Peak</p>
Avg.	 <p>Date: 2017-07-31</p> <p>Site : 03CH13-HY Condition : AVG_BE_54 3m HORN_91200_1522 VERTICAL RBW:1000.000KHz VBW:3.000KHz SWT:Auto Detector : Peak</p>	Left blank

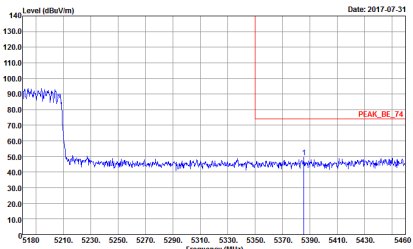
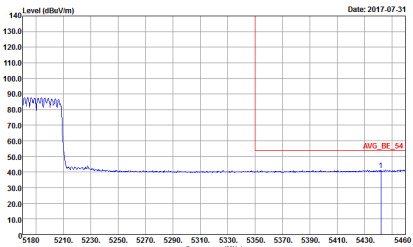

WIFI	Band 1 5150~5250MHz Band Edge @ 3m	
ANT	802.11n HT40 CH38 5190MHz - R	
1+2	Vertical	Fundamental
<p>Peak</p>	 <p>Date: 2017-07-31</p> <p>Site : 03CH13-HY Condition : PEAK_BE_74 3m HORN_91200_1522 VERTICAL RBW:1000.000KHz VBW:3000.000KHz SWT:Auto Detector : Peak</p>	<p>Left blank</p>
<p>Avg.</p>	 <p>Date: 2017-07-31</p> <p>Site : 03CH13-HY Condition : AVG_BE_54 3m HORN_91200_1522 VERTICAL RBW:1000.000KHz VBW:3.000KHz SWT:Auto Detector : Peak</p>	<p>Left blank</p>

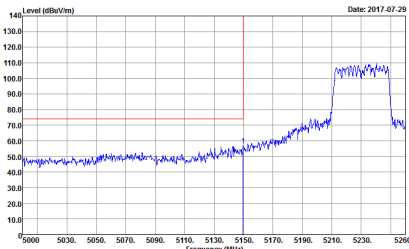
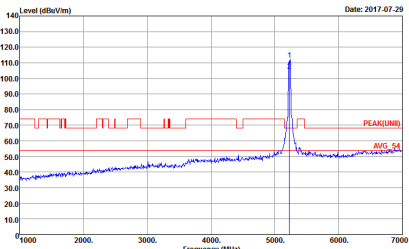
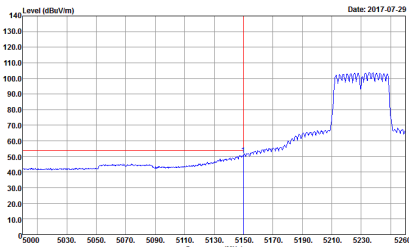

WIFI	Band 1 5150~5250MHz Band Edge @ 3m	
ANT	802.11n HT40 CH46 5230MHz - L	
1+2	Horizontal	Fundamental
Peak	 <p>Site : 03CH13-HY Condition : PEAK_BE_74 3m HORN_91200_1522 HORIZONTAL Detector : RBW:1000.000KHz VBW:3000.000KHz SWT:Auto : Peak</p>	 <p>Site : 03CH13-HY Condition : PEAK(UNIT) 3m HORN_91200_1522 HORIZONTAL Detector : RBW:1000.000KHz VBW:3000.000KHz SWT:Auto : Peak</p>
Avg.	 <p>Site : 03CH13-HY Condition : AVG_BE_54 3m HORN_91200_1522 HORIZONTAL Detector : RBW:1000.000KHz VBW:3.000KHz SWT:Auto : Peak</p>	Left blank

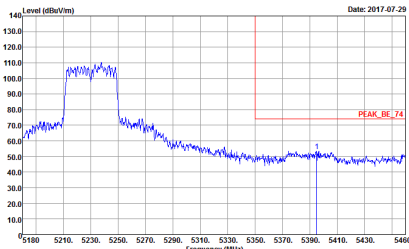
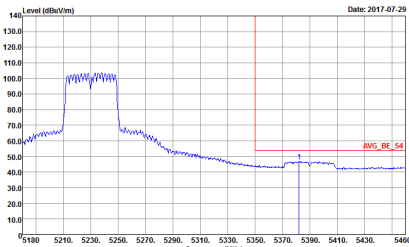

WIFI	Band 1 5150~5250MHz Band Edge @ 3m	
ANT	802.11n HT40 CH46 5230MHz - R	
1+2	Horizontal	Fundamental
Peak	 <p>Date: 2017-07-29</p> <p>Site : 03CH13-HY Condition : PEAK_BE_74 3m HORN_91200_1522 HORIZONTAL RBW:1000.000KHz VBW:3000.000KHz SWT:Auto Detector : Peak</p>	Left blank
Avg.	 <p>Date: 2017-07-29</p> <p>Site : 03CH13-HY Condition : AVG_BE_54 3m HORN_91200_1522 HORIZONTAL RBW:1000.000KHz VBW:3.000KHz SWT:Auto Detector : Peak</p>	Left blank

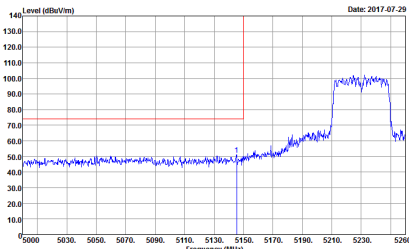
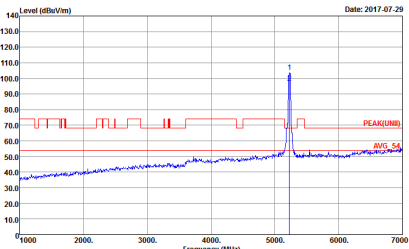
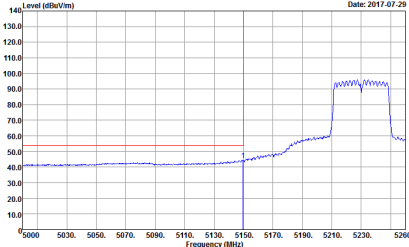

WIFI	Band 1 5150~5250MHz Band Edge @ 3m	
ANT	802.11n HT40 CH46 5230MHz - L	
1+2	Vertical	Fundamental
Peak	 <p>Level (dBuV/m) vs Frequency (MHz) plot showing a peak at 5230 MHz. The y-axis ranges from 10.0 to 140.0 dBuV/m, and the x-axis ranges from 5000 to 5260 MHz. A red vertical line is at 5150 MHz. The plot shows a rising signal starting around 5150 MHz, peaking at approximately 100 dBuV/m at 5230 MHz, and then dropping off.</p> <p>Site : 03CH13-HY Condition : PEAK_BE_74 3m HORN_91200_1522 VERTICAL RBW:1000.000KHz VBW:3000.000KHz SWT:Auto Detector : Peak</p>	 <p>Level (dBuV/m) vs Frequency (MHz) plot showing a peak at 5230 MHz. The y-axis ranges from 10.0 to 140.0 dBuV/m, and the x-axis ranges from 1000 to 7000 MHz. A red vertical line is at 5150 MHz. The plot shows a sharp peak at 5230 MHz reaching approximately 100 dBuV/m. There are also some lower-level signals between 1000 and 5000 MHz.</p> <p>Site : 03CH13-HY Condition : PEAK(UNIT) 3m HORN_91200_1522 VERTICAL RBW:1000.000KHz VBW:3000.000KHz SWT:Auto Detector : Peak</p>
Avg.	 <p>Level (dBuV/m) vs Frequency (MHz) plot showing a peak at 5230 MHz. The y-axis ranges from 10.0 to 140.0 dBuV/m, and the x-axis ranges from 5000 to 5260 MHz. A red vertical line is at 5150 MHz. The plot shows a rising signal starting around 5150 MHz, peaking at approximately 100 dBuV/m at 5230 MHz, and then dropping off.</p> <p>Site : 03CH13-HY Condition : AVG_BE_54 3m HORN_91200_1522 VERTICAL RBW:1000.000KHz VBW:3.000KHz SWT:Auto Detector : Peak</p>	Left blank

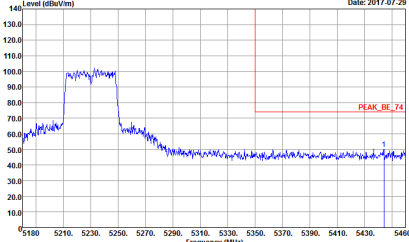
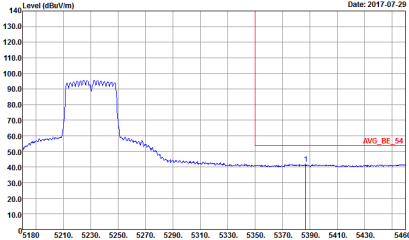

WIFI	Band 1 5150~5250MHz Band Edge @ 3m	
ANT	802.11n HT40 CH46 5230MHz - R	
1+2	Vertical	Fundamental
Peak	 <p>Site : 03CH13-HY Condition : PEAK_BE_74 3m HORN_91200_1522 VERTICAL RBW:1000.000KHz VBW:3000.000KHz SWT:Auto Detector : Peak</p>	Left blank
Avg.	 <p>Site : 03CH13-HY Condition : AVG_BE_54 3m HORN_91200_1522 VERTICAL RBW:1000.000KHz VBW:3.000KHz SWT:Auto Detector : Peak</p>	Left blank



Band 1 5150~5250MHz
WIFI 802.11ac VHT80 (Band Edge @ 3m)

Table with 2 columns (Horizontal, Fundamental) and 2 rows (Peak, Avg.). Each cell contains a spectral plot and technical details like Site, Condition, and Detector.

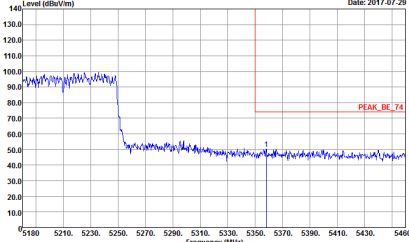
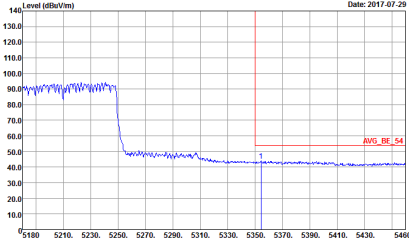

WIFI	Band 1 5150~5250MHz Band Edge @ 3m	
ANT	802.11ac VHT80 CH42 5210MHz - R	
1+2	Horizontal	Fundamental
<p>Peak</p>	 <p>Site : 03CH13-HY Condition : PEAK_BE_74 3m HORN_91200_1522 HORIZONTAL : RBW:1000.000KHz VBW:3000.000KHz SWT:Auto Detector : Peak</p>	<p>Left blank</p>
<p>Avg.</p>	 <p>Site : 03CH13-HY Condition : AVG_BE_54 3m HORN_91200_1522 HORIZONTAL : RBW:1000.000KHz VBW:10.000KHz SWT:Auto Detector : Peak</p>	<p>Left blank</p>

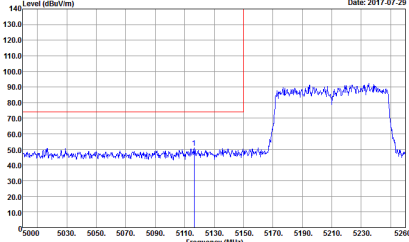
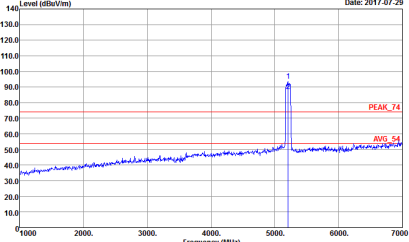
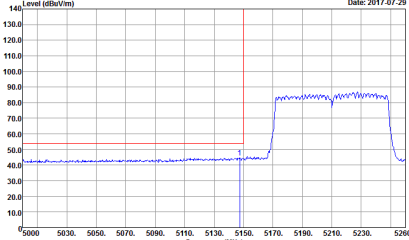

WIFI	Band 1 5150~5250MHz Band Edge @ 3m	
ANT	802.11ac VHT80 CH42 5210MHz - L	
1+2	Vertical	Fundamental
Peak	 <p>Level (dBuV/m) vs Frequency (MHz) plot for Peak Vertical. The plot shows a signal level around 80 dBuV/m between 5150 and 5210 MHz. A red vertical line is at 5150 MHz. The date is 2017-07-29.</p> <p>Site : 03CH13-HY Condition : PEAK_BE_74 3m HORN_91200_1522 VERTICAL Detector : RBW:1000.000KHz VBW:3000.000KHz SWT:Auto Detector : Peak</p>	 <p>Level (dBuV/m) vs Frequency (MHz) plot for Peak Fundamental. The plot shows a sharp peak at 5210 MHz. A red horizontal line is at 80 dBuV/m labeled 'PEAK_74'. A red horizontal line is at 50 dBuV/m labeled 'AVG_54'. The date is 2017-07-29.</p> <p>Site : 03CH13-HY Condition : PEAK_74 3m HORN_91200_1522 VERTICAL Detector : RBW:1000.000KHz VBW:3000.000KHz SWT:Auto Detector : Peak</p>
Avg.	 <p>Level (dBuV/m) vs Frequency (MHz) plot for Avg. Vertical. The plot shows a signal level around 80 dBuV/m between 5150 and 5210 MHz. A red vertical line is at 5150 MHz. The date is 2017-07-29.</p> <p>Site : 03CH13-HY Condition : AVG_BE_54 3m HORN_91200_1522 VERTICAL Detector : RBW:1000.000KHz VBW:10.000KHz SWT:Auto Detector : Peak</p>	Left blank



WIFI	Band 1 5150~5250MHz Band Edge @ 3m	
ANT	802.11ac VHT80 CH42 5210MHz - R	
1+2	Vertical	Fundamental
<p>Peak</p>	<p>Date: 2017-07-29</p> <p>Site : 03CH13-HY Condition : PEAK_BE_74 3m HORN_91200_1522 VERTICAL RBW:1000.000KHz VBW:3000.000KHz SWT:Auto Detector : Peak</p>	<p>Left blank</p>
<p>Avg.</p>	<p>Date: 2017-07-29</p> <p>Site : 03CH13-HY Condition : AVG_BE_54 3m HORN_91200_1522 VERTICAL RBW:1000.000KHz VBW:10.000KHz SWT:Auto Detector : Peak</p>	<p>Left blank</p>



Band 1 - 5150~5250MHz
WIFI 802.11a (Harmonic @ 3m)

WIFI	Band 1 5150~5250MHz Harmonic @ 3m	
ANT	802.11a CH36 5180MHz	
1+2	Horizontal	Vertical
<p>Peak</p> <p>Avg.</p>	<p>Site : 03CH13-HY Condition : PEAK(UMI) 3m SHF_HORN_584 HORIZONTAL Detector : Peak</p>	<p>Site : 03CH13-HY Condition : PEAK(UMI) 3m SHF_HORN_584 VERTICAL Detector : Peak</p>



WIFI	Band 1 5150~5250MHz Harmonic @ 3m	
ANT	802.11a CH44 5220MHz	
1+2	Horizontal	Vertical
Peak Avg.	<p>Site : 03CH13-HY Condition : PEAK(UNII) 3m SHF_HORN_584 HORIZONTAL Detector : Peak</p>	<p>Site : 03CH13-HY Condition : PEAK(UNII) 3m SHF_HORN_584 VERTICAL Detector : Peak</p>

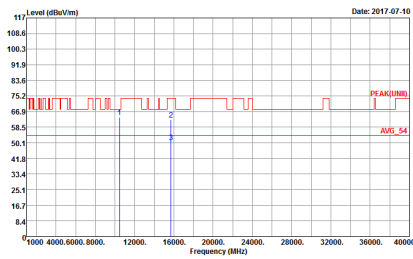
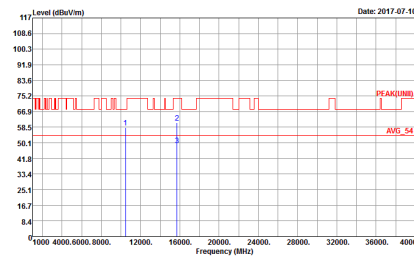

WIFI	Band 1 5150~5250MHz Harmonic @ 3m	
ANT	802.11a CH48 5240MHz	
1+2	Horizontal	Vertical
<p>Peak</p> <p>Avg.</p>	 <p>Date: 2017-07-10</p> <p>Site : 03CH13-HY Condition : PEAK(UNII) 3m SHF_HORN_584 HORIZONTAL Detector : Peak</p>	 <p>Date: 2017-07-10</p> <p>Site : 03CH13-HY Condition : PEAK(UNII) 3m SHF_HORN_584 VERTICAL Detector : Peak</p>



Band 1 5150~5250MHz
WIFI 802.11n HT20 (Harmonic @ 3m)

WIFI	Band 1 5150~5250MHz Harmonic @ 3m	
ANT	802.11n HT20 CH36 5180MHz	
1+2	Horizontal	Vertical
Peak Avg.	<p>Site : 03CH13-HY Condition : PEAK(UNII) 3m SHF_HORN_584 HORIZONTAL Detector : Peak</p>	<p>Site : 03CH13-HY Condition : PEAK(UNII) 3m SHF_HORN_584 VERTICAL Detector : Peak</p>

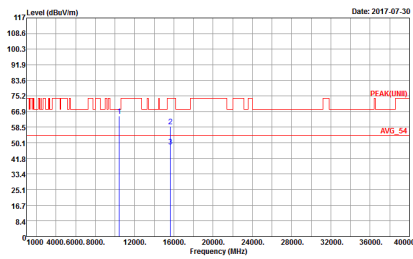
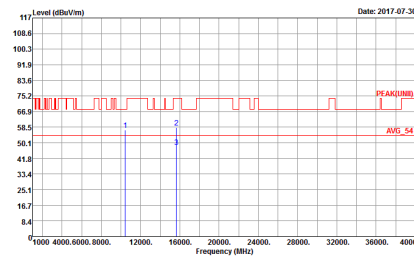

WIFI	Band 1 5150~5250MHz Harmonic @ 3m	
ANT	802.11n HT20 CH44 5220MHz	
1+2	Horizontal	Vertical
<p>Peak</p> <p>Avg.</p>	 <p>Site : 03CH13-HY Condition : PEAK(UNII) 3m SHF_HORN_584 HORIZONTAL Detector : Peak</p>	 <p>Site : 03CH13-HY Condition : PEAK(UNII) 3m SHF_HORN_584 VERTICAL Detector : Peak</p>

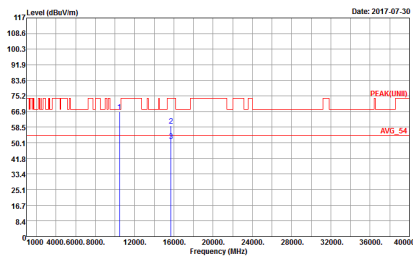
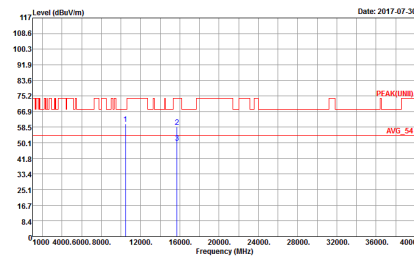

WIFI	Band 1 5150~5250MHz Harmonic @ 3m	
ANT	802.11n HT20 CH48 5240MHz	
1+2	Horizontal	Vertical
<p>Peak</p> <p>Avg.</p>	 <p>Site : 03CH13-HY Condition : PEAK(UNII) 3m SHF_HORN_584 HORIZONTAL Detector : Peak</p>	 <p>Site : 03CH13-HY Condition : PEAK(UNII) 3m SHF_HORN_584 VERTICAL Detector : Peak</p>



**Band 1 5150~5250MHz
WIFI 802.11n HT40 (Harmonic @ 3m)**

WIFI	Band 1 5150~5250MHz Harmonic @ 3m	
ANT	802.11n HT40 CH38 5190MHz	
1+2	Horizontal	Vertical
Peak Avg.	<p>Site : 03CH13-HY Condition : PEAK(UNII) 3m SHF_HORN_584 HORIZONTAL Detector : Peak</p>	<p>Site : 03CH13-HY Condition : PEAK(UNII) 3m SHF_HORN_584 VERTICAL Detector : Peak</p>



WIFI	Band 1 5150~5250MHz Harmonic @ 3m	
ANT	802.11n HT40 CH46 5230MHz	
1+2	Horizontal	Vertical
Peak Avg.	<p>Site : 03CH13-HY Condition : PEAK(UNII) 3m SHF_HORN_584 HORIZONTAL Detector : Peak</p>	<p>Site : 03CH13-HY Condition : PEAK(UNII) 3m SHF_HORN_584 VERTICAL Detector : Peak</p>



Band 1 5150~5250MHz
WIFI 802.11ac VHT80 (Harmonic @ 3m)

WIFI	Band 1 5150~5250MHz Harmonic @ 3m	
ANT	802.11ac VHT80 CH42 5210MHz	
1+2	Horizontal	Vertical
Peak Avg.	<p>Site : 03CH13-HY Condition : PEAK(UNII) 3m SHF_HORN_584 HORIZONTAL Detector : Peak</p>	<p>Site : 03CH13-HY Condition : PEAK(UNII) 3m SHF_HORN_584 VERTICAL Detector : Peak</p>



Emission below 1GHz
5GHz WIFI 802.11ac VHT80 (LF)

Table with 4 columns: WIFI, ANT, 1+2, and two sub-columns for Horizontal and Vertical. It contains two spectral plots showing Level (dBuV/m) vs Frequency (MHz) for 5GHz WIFI 802.11ac VHT80 LF. The plots show a peak level of approximately 45.7 dBuV/m. The left plot is for Horizontal polarization and the right plot is for Vertical polarization. Both plots include site information: 03CH13-HY, Condition: QP 3m BILOG_40103, and Detector: Peak.



Appendix E. Duty Cycle Plots

Antenna	Band	Duty Cycle(%)	T(us)	1/T(kHz)	VBW Setting
1 + 2	802.11a for Ant. 1	92.86	1430	0.70	1kHz
1 + 2	802.11a for Ant. 2	92.86	1430	0.70	1kHz
1 + 2	5GHz 802.11n HT20 for Ant. 1	92.41	1340	0.75	1kHz
1 + 2	5GHz 802.11n HT20 for Ant. 2	92.41	1340	0.75	1kHz
1 + 2	5GHz 802.11n HT40 for Ant. 1	85.62	655	1.53	3kHz
1 + 2	5GHz 802.11n HT40 for Ant. 2	85.71	660	1.52	3kHz
1 + 2	5GHz 802.11ac VHT20 for Ant. 1	92.47	1350	0.74	1kHz
1 + 2	5GHz 802.11ac VHT20 for Ant. 2	93.10	1350	0.74	1kHz
1 + 2	5GHz 802.11ac VHT40 for Ant. 1	87.01	670	1.49	3kHz
1 + 2	5GHz 802.11ac VHT40 for Ant. 2	85.90	670	1.49	3kHz
1 + 2	5GHz 802.11ac VHT80 for Ant. 1	75.93	328	3.05	10kHz
1 + 2	5GHz 802.11ac VHT80 for Ant. 2	76.85	332	3.01	10kHz



MIMO <Ant. 1>

802.11a

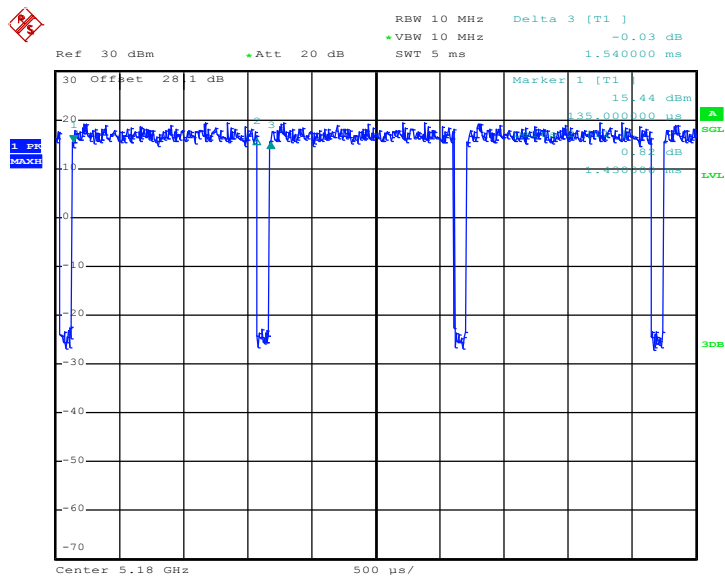

Date: 5.JUL.2017 23:46:58

802.11n HT20

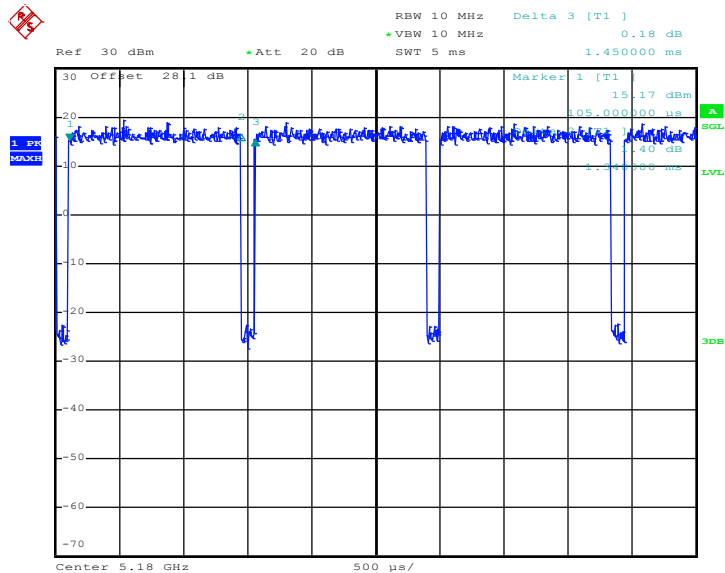

Date: 5.JUL.2017 23:50:54



802.11n HT40

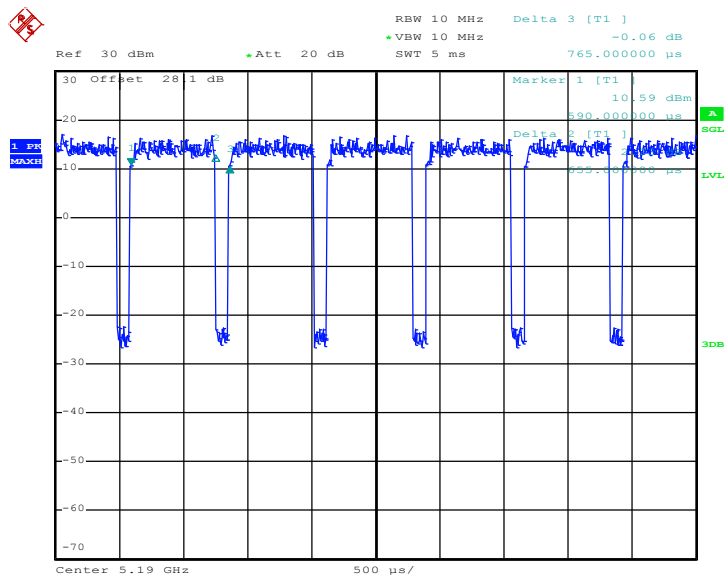

Date: 5.JUL.2017 23:52:51

802.11ac VHT20

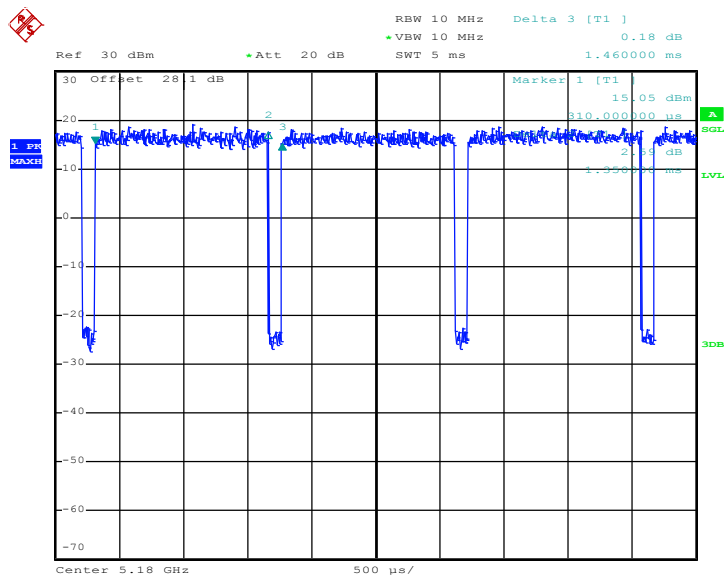

Date: 5.JUL.2017 23:55:28



802.11ac VHT40

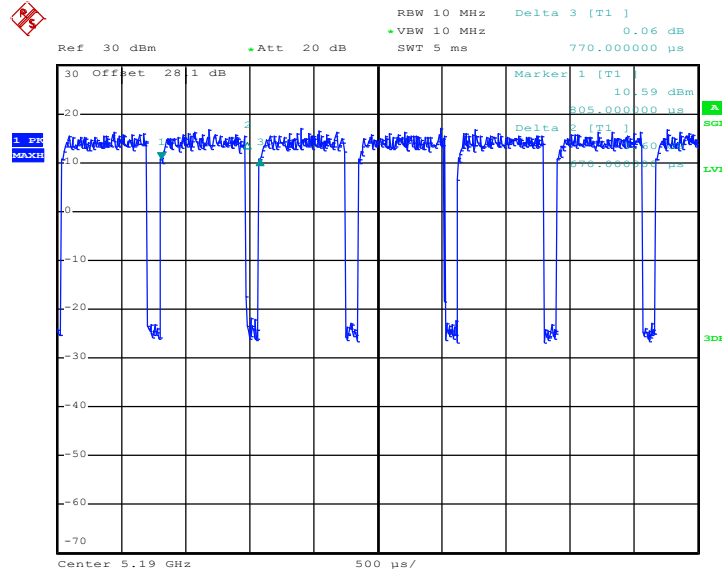

Date: 5.JUL.2017 23:59:14

802.11ac VHT80

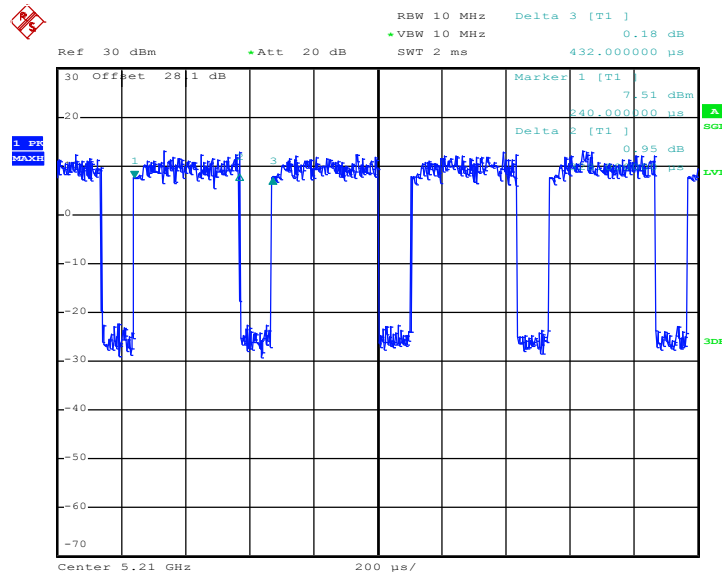

Date: 6.JUL.2017 00:01:58



MIMO <Ant. 2>

802.11a

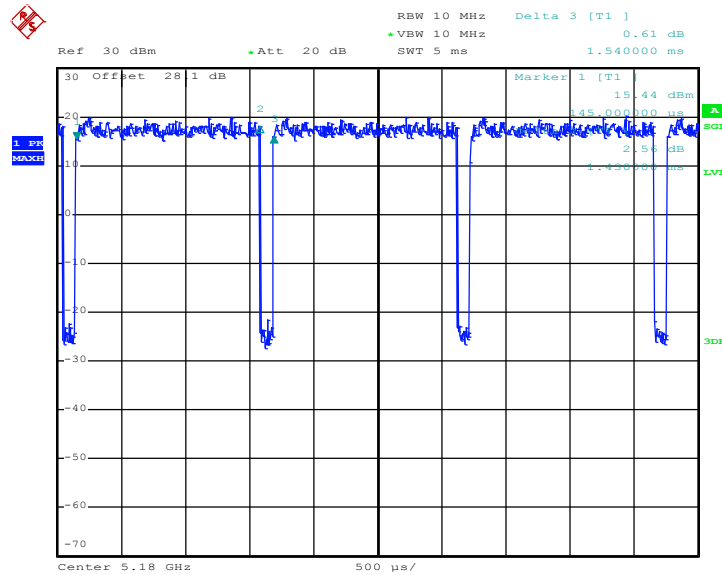

Date: 5.JUL.2017 23:47:47

802.11n HT20

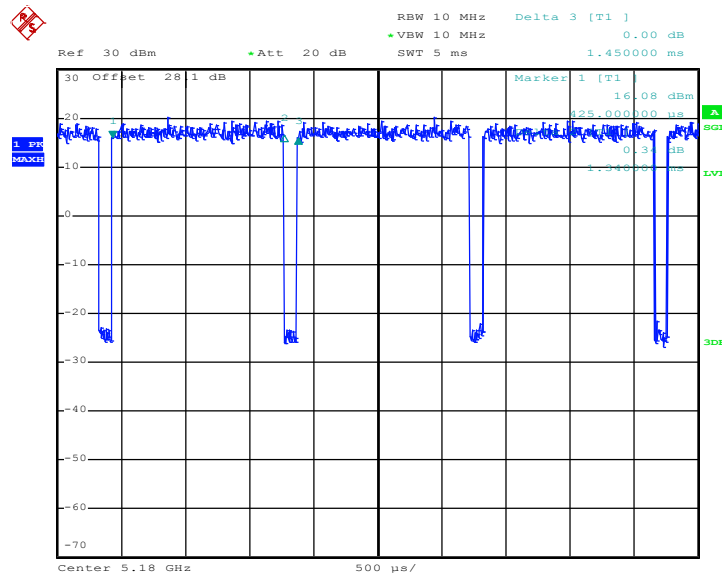

Date: 5.JUL.2017 23:51:33





802.11n HT40

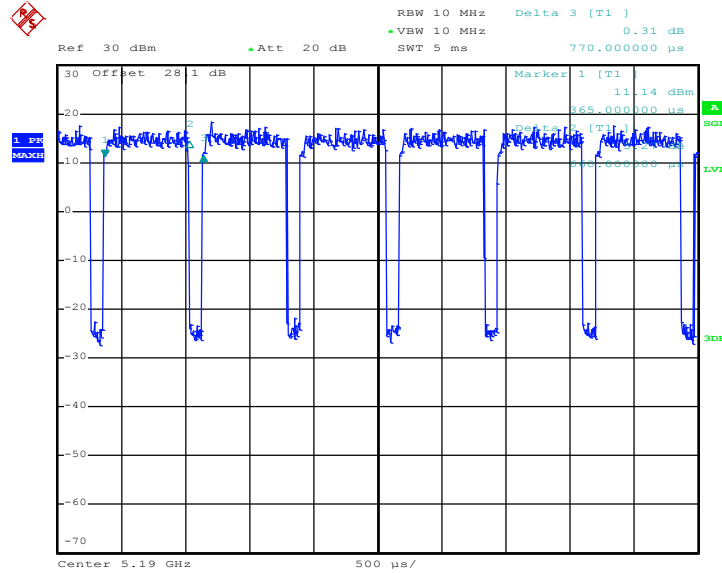

Date: 5.JUL.2017 23:53:45

802.11ac VHT20

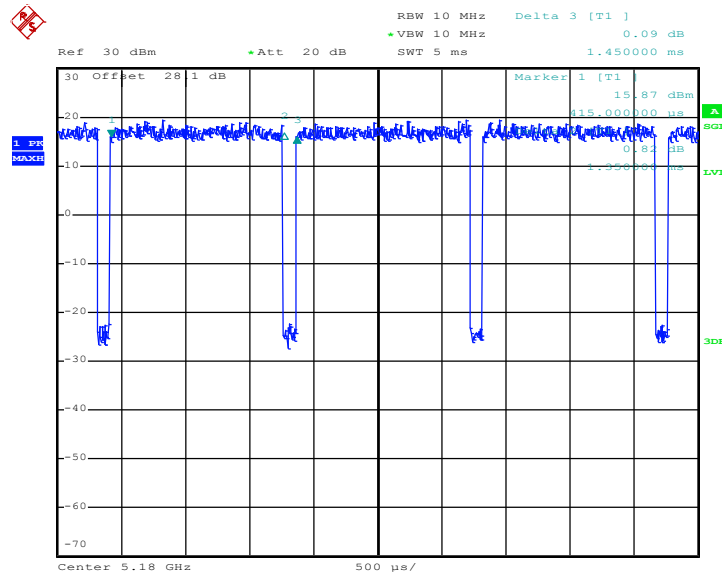

Date: 5.JUL.2017 23:56:22



802.11ac VHT40

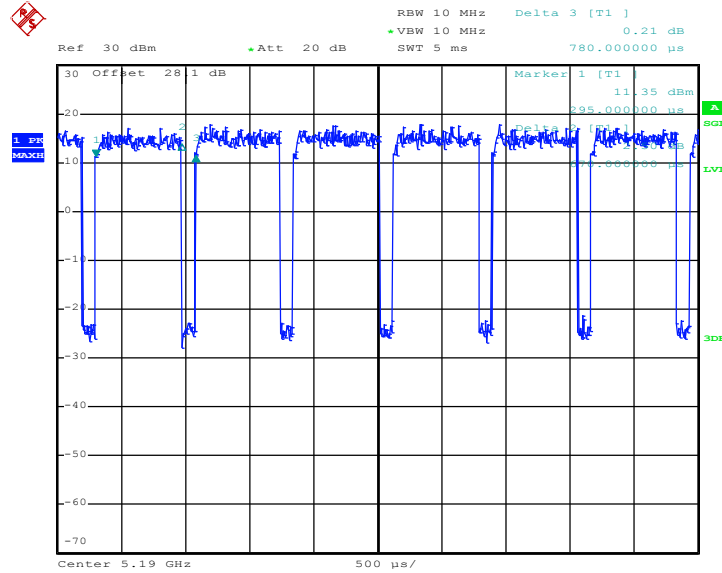

Date: 5.JUL.2017 23:59:53

802.11ac VHT80

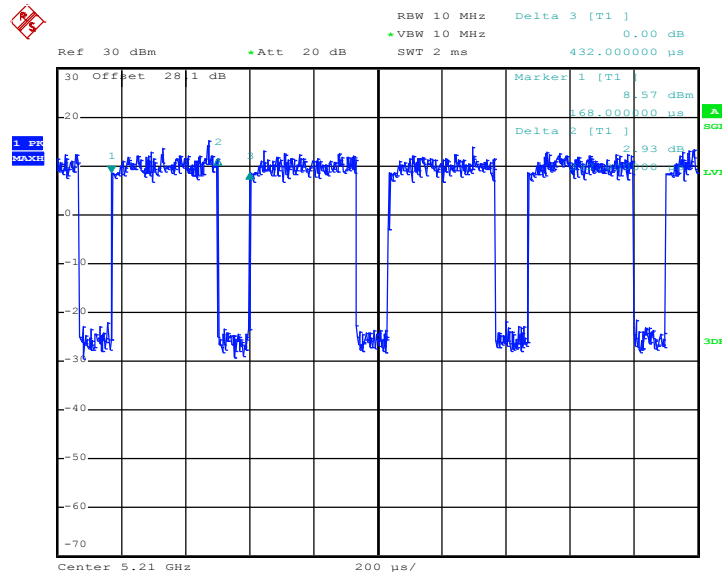

Date: 6.JUL.2017 00:02:30

THE END