



FCC RF Test Report

APPLICANT : Verdegrass LLC
EQUIPMENT : Digital Media Streaming Device
MODEL NAME : EX69VW
FCC ID : 2AJZB-0308
STANDARD : FCC Part 15 Subpart C §15.247
CLASSIFICATION : (DTS) Digital Transmission System

The product was completed on Jul. 30, 2017. We, SPORTON INTERNATIONAL INC., would like to declare that the tested sample has been evaluated in accordance with the test procedures and has been in compliance with the applicable technical standards.

The test results in this report apply exclusively to the tested model / sample. Without written approval of SPORTON INTERNATIONAL INC., the test report shall not be reproduced except in full.

Reviewed by: Joseph Lin / Supervisor

Approved by: Jones Tsai / Manager



SPORTON INTERNATIONAL INC.

No. 52, Hwa Ya 1st Rd., Hwa Ya Technology Park, Kwei-Shan District, Tao Yuan City, Taiwan, R.O.C.

SPORTON INTERNATIONAL INC.

TEL : 886-3-327-3456

FAX : 886-3-328-4978

FCC ID : 2AJZB-0308

Page Number : 1 of 56

Report Issued Date : Aug. 17, 2017

Report Version : Rev. 01

Report Template No.: BU5-FR15CWL MA Version 1.3



TABLE OF CONTENTS

REVISION HISTORY..... 3

SUMMARY OF TEST RESULT 4

1 GENERAL DESCRIPTION 5

 1.1 Applicant 5

 1.2 Product Feature of Equipment Under Test..... 5

 1.3 Product Specification of Equipment Under Test..... 6

 1.4 Modification of EUT 6

 1.5 Testing Location 7

 1.6 Applicable Standards..... 7

2 TEST CONFIGURATION OF EQUIPMENT UNDER TEST 8

 2.1 Carrier Frequency and Channel 8

 2.2 Test Mode..... 9

 2.3 Connection Diagram of Test System..... 10

 2.4 Support Unit used in test configuration and system 11

 2.5 EUT Operation Test Setup 11

 2.6 Measurement Results Explanation Example..... 11

3 TEST RESULT 12

 3.1 6dB and 99% Bandwidth Measurement 12

 3.2 Peak Output Power Measurement 14

 3.3 Power Spectral Density Measurement 15

 3.4 Conducted Band Edges and Spurious Emission Measurement 17

 3.5 Radiated Band Edges and Spurious Emission Measurement 48

 3.6 AC Conducted Emission Measurement..... 52

 3.7 Antenna Requirements 54

4 LIST OF MEASURING EQUIPMENT 55

5 UNCERTAINTY OF EVALUATION 56

APPENDIX A. CONDUCTED TEST RESULTS

APPENDIX B. AC CONDUCTED EMISSION TEST RESULTS

APPENDIX C. RADIATED SPURIOUS EMISSION

APPENDIX D. RADIATED SPURIOUS EMISSION PLOTS

APPENDIX E. DUTY CYCLE PLOTS



SUMMARY OF TEST RESULT

Report Section	FCC Rule	Description	Limit	Result
3.1	15.247(a)(2)	6dB Bandwidth	$\geq 0.5\text{MHz}$	Pass
3.1	-	99% Bandwidth	-	Pass
3.2	15.247(b)	Power Output Measurement	$\leq 30\text{dBm}$	Pass
3.3	15.247(e)	Power Spectral Density	$\leq 8\text{dBm}/3\text{kHz}$	Pass
3.4	15.247(d)	Conducted Band Edges	$\leq 20\text{dBc}$	Pass
		Conducted Spurious Emission		Pass
3.5	15.247(d)	Radiated Band Edges and Radiated Spurious Emission	15.209(a) & 15.247(d)	Pass
3.6	15.207	AC Conducted Emission	15.207(a)	Pass
3.7	15.203 & 15.247(b)	Antenna Requirement	N/A	Pass



1 General Description

1.1 Applicant

Verdegrass LLC

233 South 13th Street, Suite 1100, Lincoln, Nebraska 68508

1.2 Product Feature of Equipment Under Test

Product Feature	
Equipment	Digital Media Streaming Device
Model Name	EX69VW
FCC ID	2AJZB-0308
EUT supports Radios application	WLAN 11a/b/g/n HT20/HT40 WLAN 11ac VHT20/VHT40/VHT80 Bluetooth BR/EDR/LE



1.3 Product Specification of Equipment Under Test

Standards-related Product Specification										
Tx/Rx Channel Frequency Range	2412 MHz ~ 2472 MHz									
Maximum (Peak) Output Power to antenna	<p><Ant. 1> 802.11b : 22.62 dBm (0.1828 W)</p> <p><Ant. 2> 802.11b : 22.31 dBm (0.1702 W)</p> <p>MIMO <Ant. 1 + 2> 802.11g : 27.76 dBm (0.5970 W) 802.11n HT20 : 27.06 dBm (0.5082 W)</p>									
99% Occupied Bandwidth	<p><Ant. 1> 802.11b : 11.70MHz</p> <p><Ant. 2> 802.11b : 11.65MHz</p> <p>MIMO<Ant. 1> 802.11g : 18.55MHz 802.11n HT20 : 19.25MHz</p> <p>MIMO<Ant. 2> 802.11g : 18.15MHz 802.11n HT20 : 19.20MHz</p>									
Antenna Type / Gain	<p><Ant 1> Fixed internal Antenna with gain 2.43 dBi</p> <p><Ant 2> Fixed internal Antenna with gain 2.07 dBi</p>									
Type of Modulation	802.11b : DSSS (DBPSK / DQPSK / CCK) 802.11g/n : OFDM (BPSK / QPSK / 16QAM / 64QAM)									
Antenna Function for Transmitter	<table border="1"> <thead> <tr> <th></th> <th>Ant. 1</th> <th>Ant. 2</th> </tr> </thead> <tbody> <tr> <td>802.11 b</td> <td>V</td> <td>V</td> </tr> <tr> <td>802.11 g/n MIMO</td> <td>V</td> <td>V</td> </tr> </tbody> </table>		Ant. 1	Ant. 2	802.11 b	V	V	802.11 g/n MIMO	V	V
	Ant. 1	Ant. 2								
802.11 b	V	V								
802.11 g/n MIMO	V	V								

Note: MIMO Ant. 1+2 is a calculated result from sum of the power MIMO Ant. 1 and MIMO Ant. 2.

1.4 Modification of EUT

No modifications are made to the EUT during all test items.



1.5 Testing Location

Sporton Lab is accredited to ISO 17025 by Taiwan Accreditation Foundation (TAF code : 1190) and the FCC designation No. TW0007 under the FCC 2.948(e) by Mutual Recognition Agreement (MRA) in FCC Test.

Test Site	SPORTON INTERNATIONAL INC.	
Test Site Location	No. 52, Hwa Ya 1 st Rd., Hwa Ya Technology Park, Kwei-Shan District, Tao Yuan City, Taiwan, R.O.C. TEL: +886-3-327-3456 FAX: +886-3-328-4978	
Test Site No.	Sporton Site No.	
	TH05-HY	CO05-HY

Note: The test site complies with ANSI C63.4 2014 requirement.

Test Site	SPORTON INTERNATIONAL INC.	
Test Site Location	No.58, Aly. 75, Ln. 564, Wenhua 3rd Rd. Guishan Dist, Taoyuan City, Taiwan (R.O.C.) TEL: +886-3-327-0868 FAX: +886-3-327-0855	
Test Site No.	Sporton Site No.	
	03CH13-HY	

Note: The test site complies with ANSI C63.4 2014 requirement.

1.6 Applicable Standards

According to the specifications of the manufacturer, the EUT must comply with the requirements of the following standards:

- ♦ FCC Part 15 Subpart C §15.247
- ♦ FCC KDB Publication No. 558074 D01 DTS Meas. Guidance v04
- ♦ FCC KDB 662911 D01 Multiple Transmitter Output v02r01.
- ♦ ANSI C63.10-2013

Remark: All test items were verified and recorded according to the standards and without any deviation during the test.



2 Test Configuration of Equipment Under Test

The EUT has been associated with peripherals and configuration operated in a manner tended to maximize its emission characteristics in a typical application. Frequency range investigated: conducted emission (150 kHz to 30 MHz) and radiated emission (9 kHz to the 10th harmonic of the highest fundamental frequency or to 40 GHz, whichever is lower). For radiated measurement, all the possible configuration was pre-scanned with power adaptor and peripherals (HDMI, USB and IR connector). It was determined that the worst configuration was EUT with adaptor but no peripherals. The final radiated testing was performed with EUT with adaptor but no peripherals.

2.1 Carrier Frequency and Channel

Frequency Band	Channel	Freq. (MHz)	Channel	Freq. (MHz)
2400-2483.5 MHz	1	2412	8	2447
	2	2417	9	2452
	3	2422	10	2457
	4	2427	11	2462
	5	2432	12	2467
	6	2437	13	2472
	7	2442		



2.2 Test Mode

Final test mode of conducted test items and radiated spurious emissions are considering the modulation and worse data rates as below table.

Single Antenna

Modulation	Data Rate
802.11b	1 Mbps

MIMO Antenna

Modulation	Data Rate
802.11g	6 Mbps
802.11n HT20	MCS0

Test Cases	
AC Conducted Emission	Mode 1 : WLAN (2.4GHz) Link + Bluetooth Link + LED On + MPEG4 (Maximum Resolution) + IR On + Adapter

2.3 Connection Diagram of Test System

<WLAN Tx Mode>

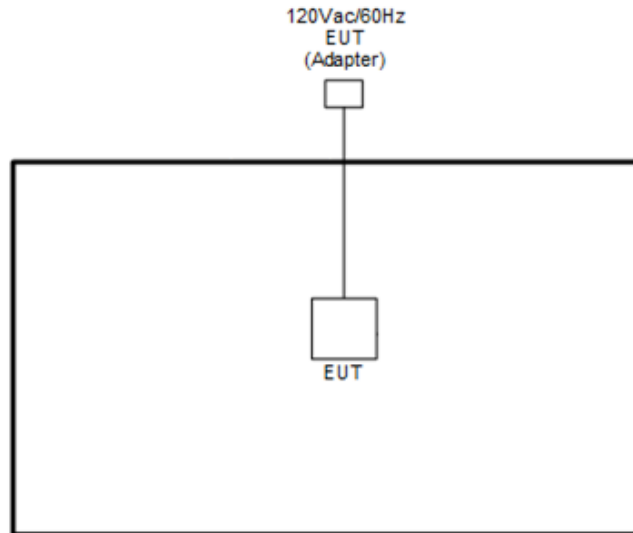

<AC Conducted Emission Mode>

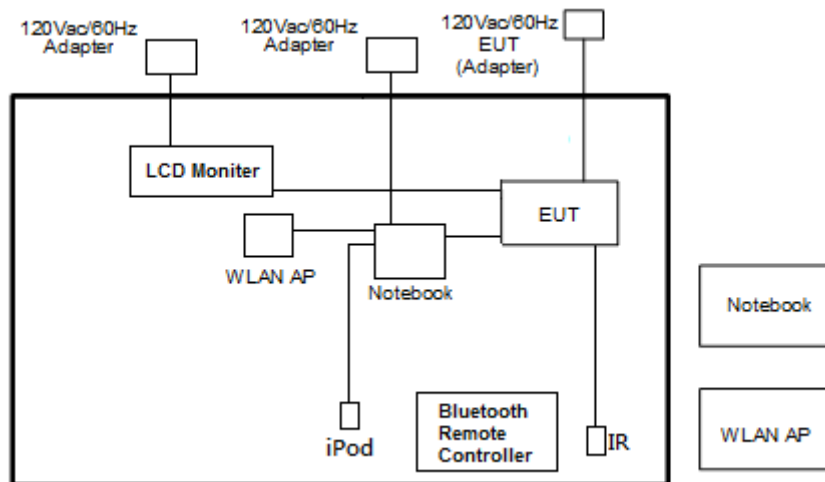



2.4 Support Unit used in test configuration and system

Item	Equipment	Trade Name	Model Name	FCC ID	Data Cable	Power Cord
1.	WLAN AP	ASUS	RT-AC66U	MSQ-RTAC66U	N/A	Unshielded, 1.8 m
2.	iPod	Apple	A1285	DoC	Shielded, 1.0m	N/A
3.	NOTE BOOK	DELL	E5570	FCC DoC	N/A	AC I/P: Unshielded, 1.2 m DC O/P: Shielded, 1.8 m
4.	NOTE BOOK	DELL	Latitude E6320	FCC DoC	N/A	AC I/P: Unshielded, 1.2 m DC O/P: Shielded, 1.8 m
5.	LCD Monitor	Sony	KD-55X8500D	FCC DoC	Shielded, 1.6 m	Unshielded, 1.8 m

2.5 EUT Operation Test Setup

The RF test items, programmed RF utility, "CMD" installed in the notebook make the EUT provide functions like channel selection and power level for continuous transmitting and receiving signals.

2.6 Measurement Results Explanation Example

For all conducted test items:

The offset level is set in the spectrum analyzer to compensate the RF cable loss and attenuator factor between EUT conducted output port and spectrum analyzer. With the offset compensation, the spectrum analyzer reading level is exactly the EUT RF output level.

Example:

The spectrum analyzer offset is derived from RF cable loss and attenuator factor.

Offset = RF cable loss + attenuator factor.

Following shows an offset computation example with cable loss 4.2 dB and 10dB attenuator.

$$\begin{aligned} \text{Offset(dB)} &= \text{RF cable loss(dB)} + \text{attenuator factor(dB)}. \\ &= 4.2 + 10 = 14.2 \text{ (dB)} \end{aligned}$$

3 Test Result

3.1 6dB and 99% Bandwidth Measurement

3.1.1 Limit of 6dB and 99% Bandwidth

The minimum 6 dB bandwidth shall be at least 500 kHz.

3.1.2 Measuring Instruments

The measuring equipment is listed in the section 4 of this test report.

3.1.3 Test Procedures

1. The testing follows FCC KDB Publication No. 558074 DTS D01 Meas. Guidance v04.
2. The RF output of EUT was connected to the spectrum analyzer by RF cable and attenuator. The path loss was compensated to the results for each measurement.
3. Set to the maximum power setting and enable the EUT transmit continuously.
4. Make the measurement with the spectrum analyzer's resolution bandwidth (RBW) = 100 kHz. Set the Video bandwidth (VBW) = 300 kHz. In order to make an accurate measurement. The 6 dB bandwidth must be greater than 500 kHz.
5. For 99% Bandwidth Measurement, the spectrum analyzer's resolution bandwidth (RBW) = 1MHz and set the Video bandwidth (VBW) = 3MHz
6. Measure and record the results in the test report.

3.1.4 Test Setup





3.1.5 Test Result of 6dB and 99% Occupied Bandwidth

Please refer to Appendix A.

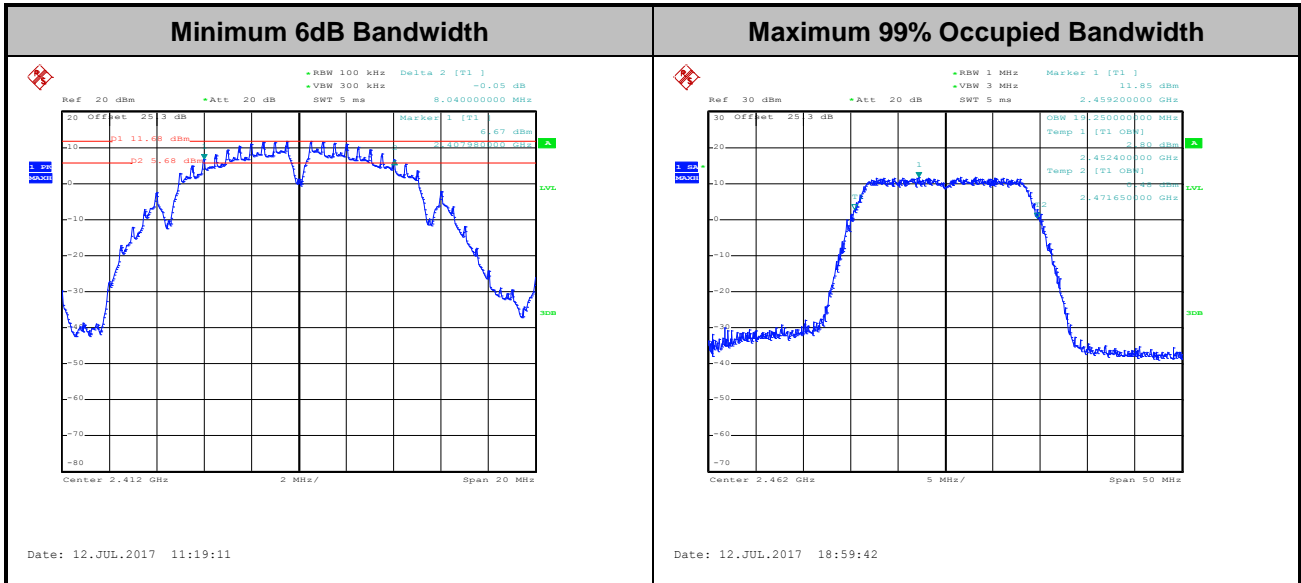

Note : The occupied channel bandwidth is maintained within the band of operation for all of the modulations.

3.2 Peak Output Power Measurement

3.2.1 Limit of Peak Output Power

For systems using digital modulation in the 2400-2483.5MHz, the limit for peak output power is 30dBm. If transmitting antenna with directional gain greater than 6dBi is used, the peak output power from the intentional radiator shall be reduced below the above stated value by the amount in dB that the directional gain of the antenna exceeds 6 dBi. In case of point-to-point operation, the limit has to be reduced by 1dB for every 3dB that the directional gain of the antenna exceeds 6dBi.

3.2.2 Measuring Instruments

The measuring equipment is listed in the section 4 of this test report.

3.2.3 Test Procedures

1. The testing follows the Measurement Procedure of FCC KDB No. 558074 DTS D01 Meas. Guidance v04 section 9.1.3 PKPM1 Peak power meter method.
2. The RF output of EUT was connected to the power meter by RF cable and attenuator. The path loss was compensated to the results for each measurement.
3. Set to the maximum power setting and enable the EUT transmit continuously.
4. Measure the conducted output power and record the results in the test report.
5. For MIMO mode, calculation method follows FCC KDB 662911 D01 Multiple Transmitter Output v02r01.

3.2.4 Test Setup

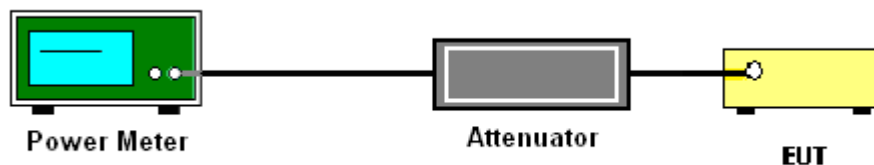

3.2.5 Test Result of Peak Output Power

Please refer to Appendix A.

3.2.6 Test Result of Average output Power (Reporting Only)

Please refer to Appendix A



3.3 Power Spectral Density Measurement

3.3.1 Limit of Power Spectral Density

The peak power spectral density shall not be greater than 8dBm in any 3kHz band at any time interval of continuous transmission.

3.3.2 Measuring Instruments

The measuring equipment is listed in the section 4 of this test report.

3.3.3 Test Procedures

1. The testing follows Measurement Procedure 10.2 Method PKPSD of FCC KDB Publication No. 558074 D01 DTS Meas. Guidance v04.
2. The RF output of EUT was connected to the spectrum analyzer by RF cable and attenuator. The path loss was compensated to the results for each measurement.
3. Set to the maximum power setting and enable the EUT transmit continuously.
4. Make the measurement with the spectrum analyzer's resolution bandwidth (RBW) = 3 kHz. Video bandwidth VBW = 10 kHz In order to make an accurate measurement, set the span to 1.5 times DTS Channel Bandwidth. (6dB BW)
5. Detector = peak, Sweep time = auto couple, Trace mode = max hold, Allow trace to fully stabilize. Use the peak marker function to determine the maximum power level.
6. Measure and record the results in the test report.
7. For MIMO mode, calculation method follows FCC KDB 662911 D01 Multiple Transmitter Output v02r01.

If measurements performed using method (2) plus $10 \log(N)$ exceeds the emission limit, the test should choose method (1) before declaring that the device fails the emission limit.

Method (1): Measure and sum the spectra across the outputs.

The total final Power Spectral Density is from a device with 2 transmitter outputs. The spectrum measurements of the individual outputs are all performed with the same span and number of points, the spectrum value in the first spectral bin of output 1 is summed with that in the first spectral bin of output 2 to obtain the value for the first frequency bin of the summed spectrum.

Method (2): Measure and add $10 \log(N)$ dB, where N is the number of outputs. (N=2)

3.4 Conducted Band Edges and Spurious Emission Measurement

3.4.1 Limit of Conducted Band Edges and Spurious Emission Measurement

In any 100 kHz bandwidth outside of the authorized frequency band, the emissions which fall in the non-restricted bands shall be attenuated at least 20 dB / 30dB relative to the maximum PSD level in 100 kHz by RF conducted measurement

3.4.2 Measuring Instruments

The measuring equipment is listed in the section 4 of this test report.

3.4.3 Test Procedures

1. The testing follows FCC KDB Publication No. 558074 D01 DTS Meas. Guidance v04.
2. The RF output of EUT was connected to the spectrum analyzer by RF cable and attenuator. The path loss was compensated to the results for each measurement.
3. Set to the maximum power setting and enable the EUT transmit continuously.
4. Set RBW = 100 kHz, VBW=300 kHz, Peak Detector. Unwanted Emissions measured in any 100 kHz bandwidth outside of the authorized frequency band shall be attenuated by at least 20 dB relative to the maximum in-band peak PSD level in 100 kHz when maximum peak conducted output power procedure is used. If the transmitter complies with the conducted power limits based on the use of RMS averaging over a time interval, the attenuation required under this paragraph shall be 30 dB instead of 20 dB.
5. Measure and record the results in the test report.
6. The RF fundamental frequency should be excluded against the limit line in the operating frequency band.

3.4.4 Test Setup

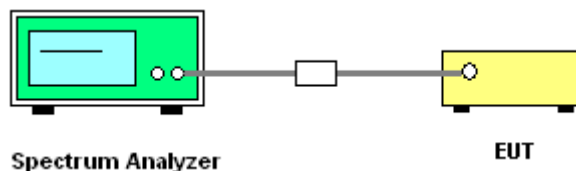



3.4.5 Test Result of Conducted Band Edges and Spurious Emission

Number of TX = 1, Ant. 1 (Measured)

Number of TX	1	Ant. :	1
Test Mode :	802.11b	Temperature :	21~25°C
Test Band :	2.4GHz Low	Relative Humidity :	51~54%
Test Channel :	01	Test Engineer :	Aking Chang

WLAN 802.11b Channel 01

100kHz PSD reference Level

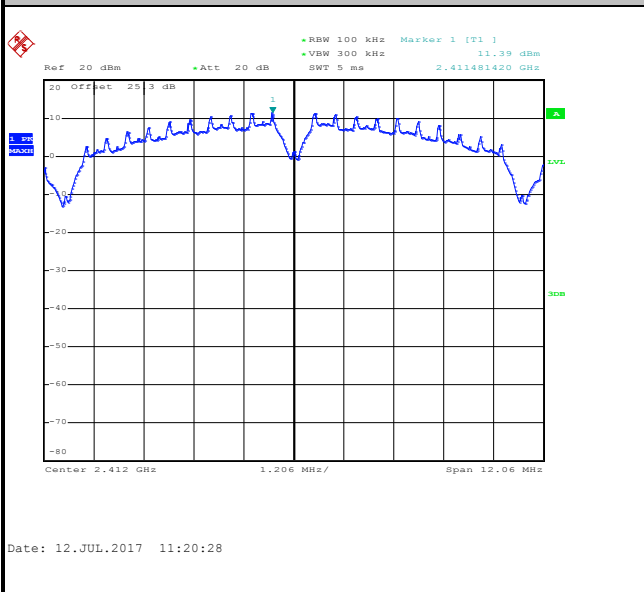

Low Channel Plot

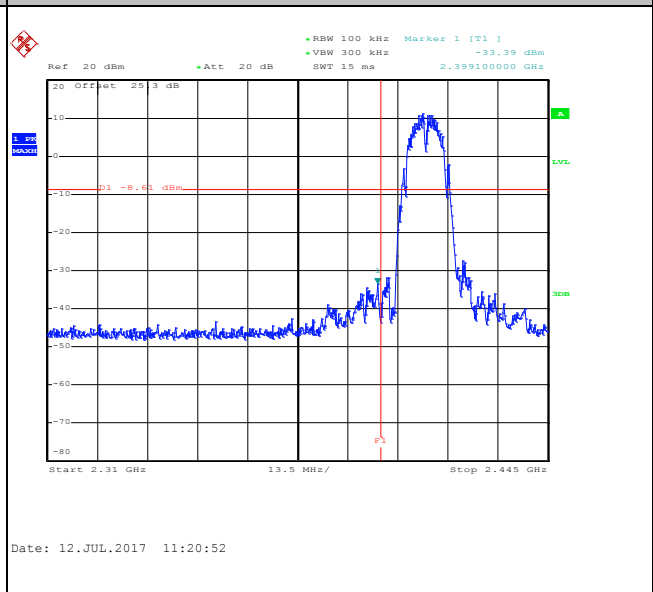

Spurious Emission 30MHz~3GHz

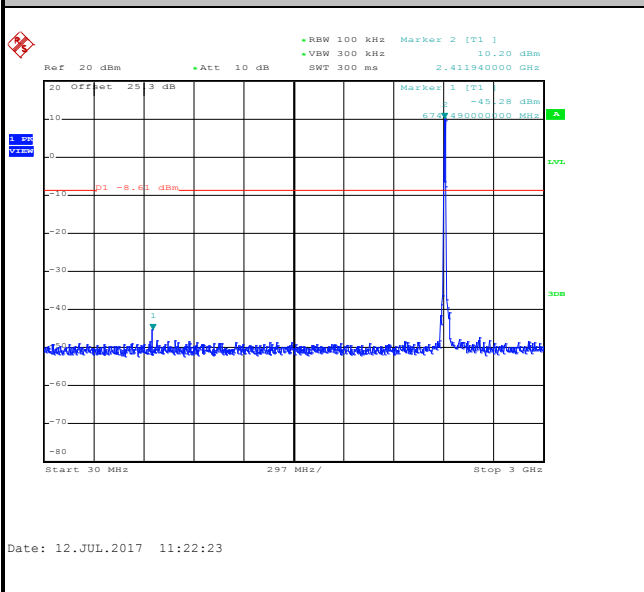

Spurious Emission 2GHz~25GHz

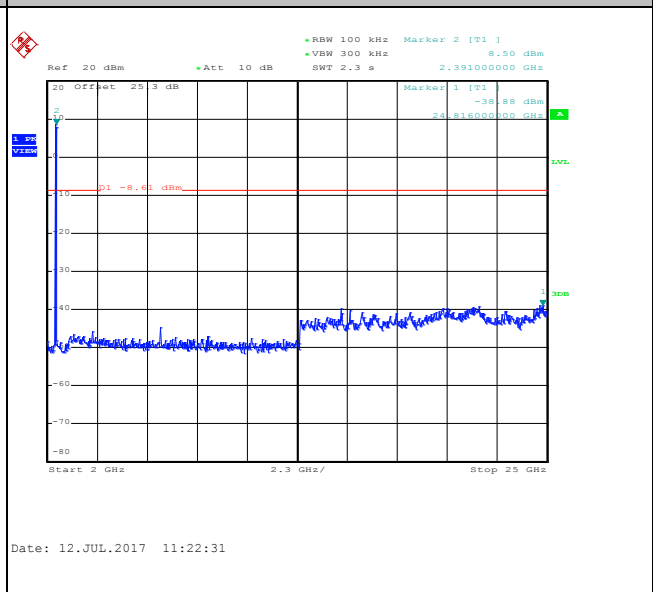



Number of TX :	1	Ant. :	1
Test Mode :	802.11b	Temperature :	21~25°C
Test Band :	2.4GHz Mid	Relative Humidity :	51~54%
Test Channel :	06	Test Engineer :	Aking Chang

WLAN 802.11b Channel 06

100kHz PSD reference Level

Mid Channel Plot

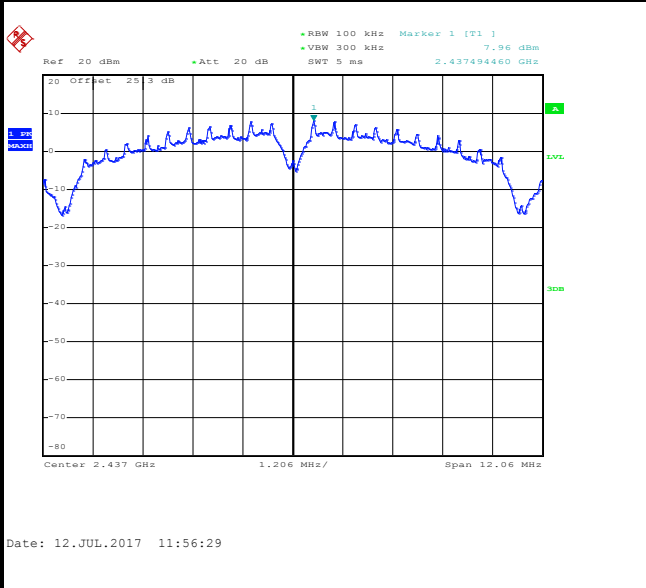

Spurious Emission 30MHz~3GHz

Spurious Emission 2GHz~25GHz

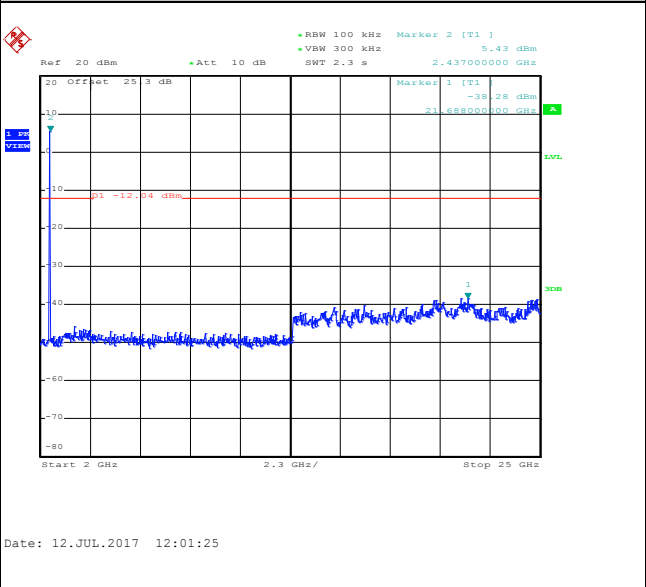
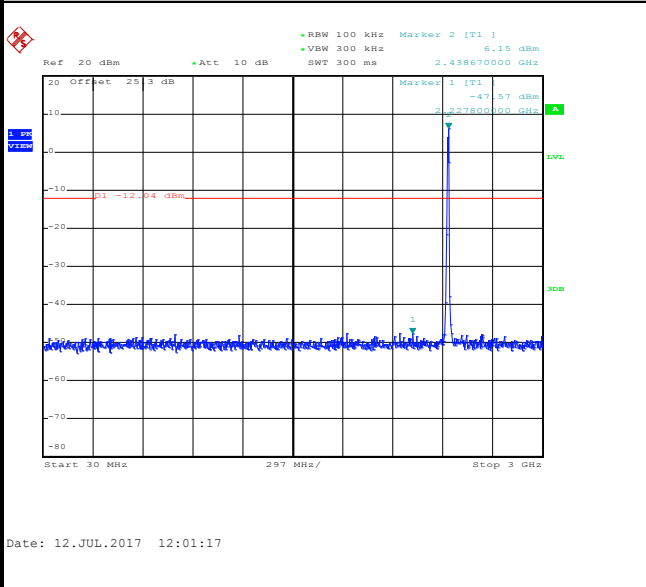



Number of TX :	1	Ant. :	1
Test Mode :	802.11b	Temperature :	21~25°C
Test Band :	2.4GHz High	Relative Humidity :	51~54%
Test Channel :	11	Test Engineer :	Aking Chang

WLAN 802.11b Channel 11

100kHz PSD reference Level

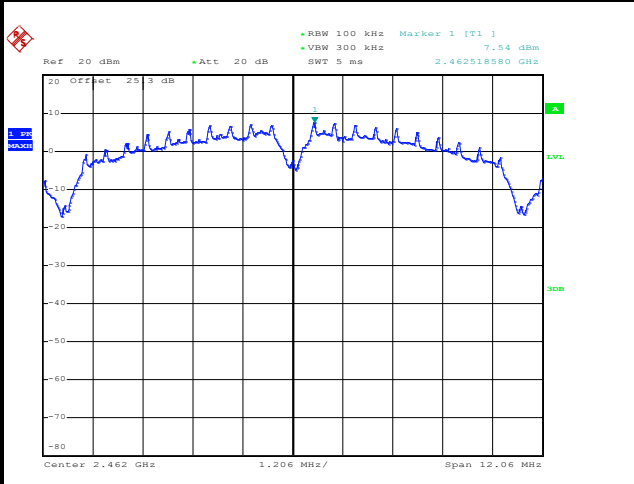

Date: 12.JUL.2017 14:50:29

High Channel Plot

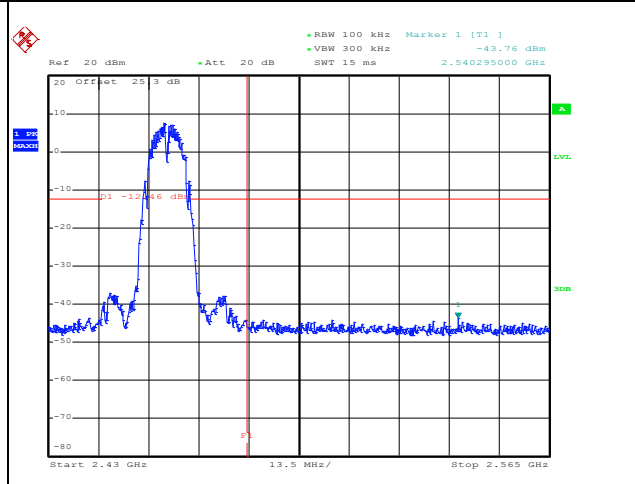

Date: 12.JUL.2017 14:50:59

Spurious Emission 30MHz~3GHz

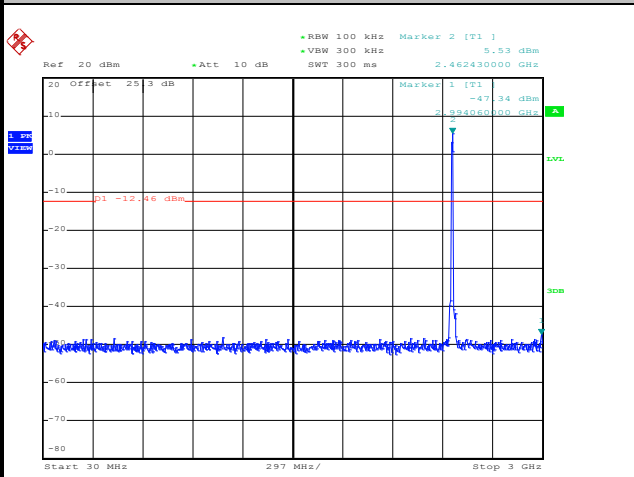

Date: 12.JUL.2017 14:51:42

Spurious Emission 2GHz~25GHz

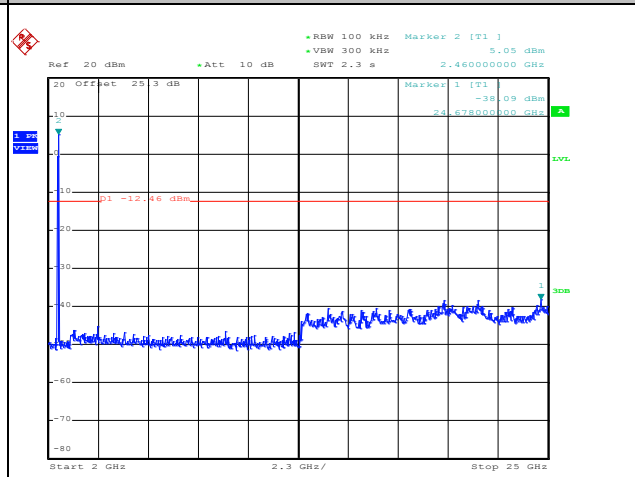

Date: 12.JUL.2017 14:51:51



Number of TX :	1	Ant. :	1
Test Mode :	802.11b	Temperature :	21~25°C
Test Band :	2.4GHz High	Relative Humidity :	51~54%
Test Channel :	12	Test Engineer :	Aking Chang

WLAN 802.11b Channel 12

100kHz PSD reference Level

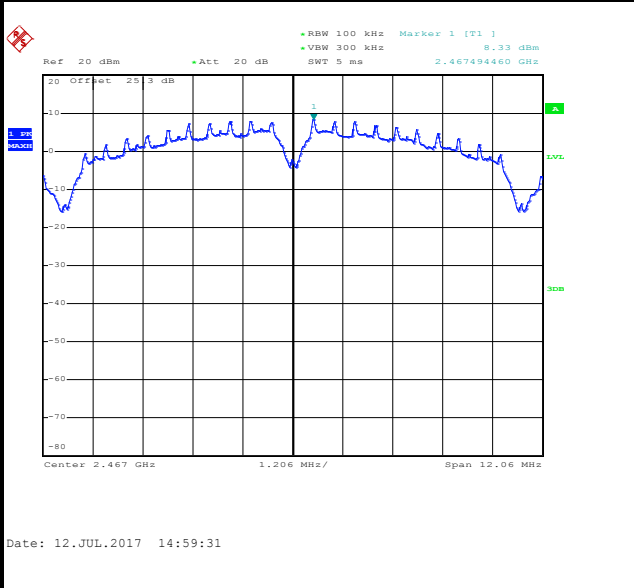

High Channel Plot

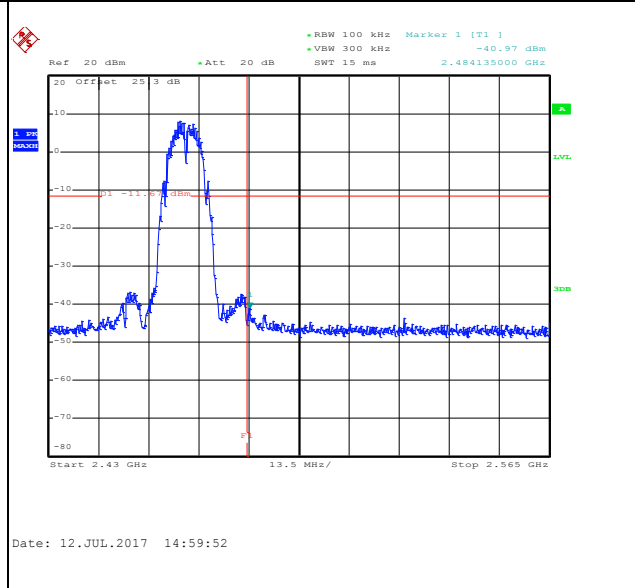

Spurious Emission 30MHz~3GHz

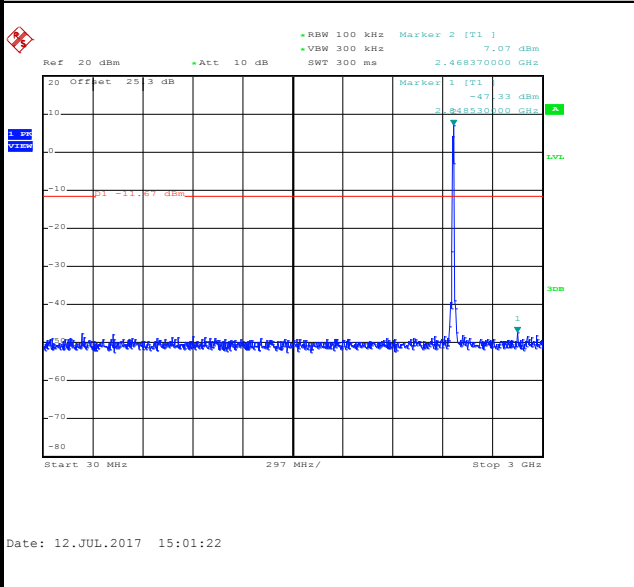

Spurious Emission 2GHz~25GHz

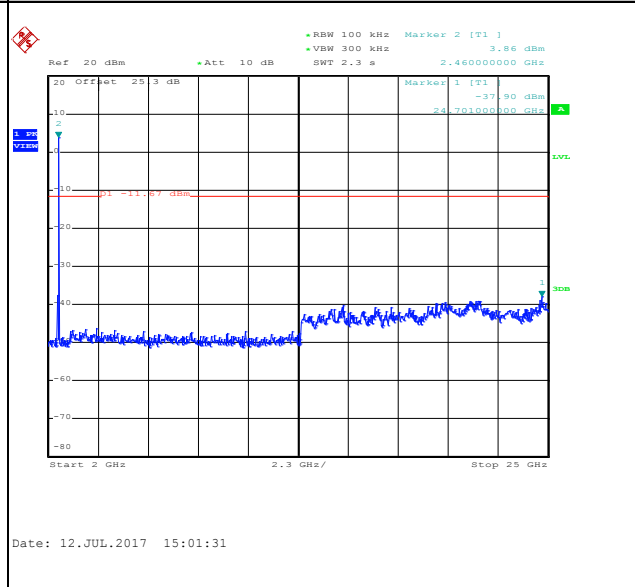



Number of TX :	1	Ant. :	1
Test Mode :	802.11b	Temperature :	21~25°C
Test Band :	2.4GHz High	Relative Humidity :	51~54%
Test Channel :	13	Test Engineer :	Aking Chang

WLAN 802.11b Channel 13

100kHz PSD reference Level

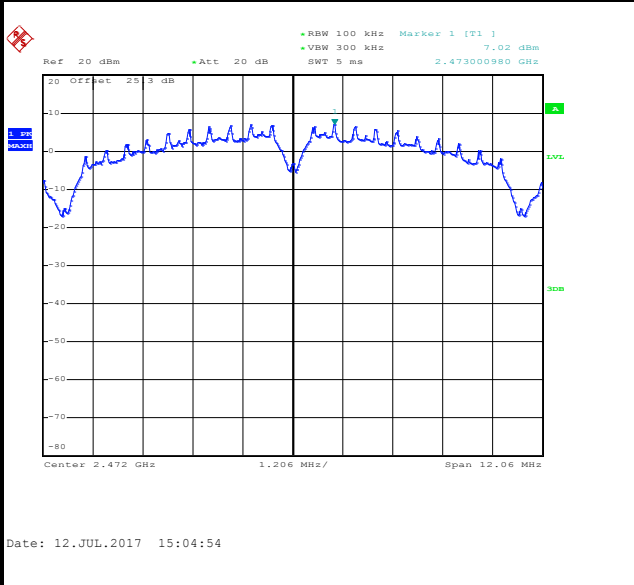

High Channel Plot

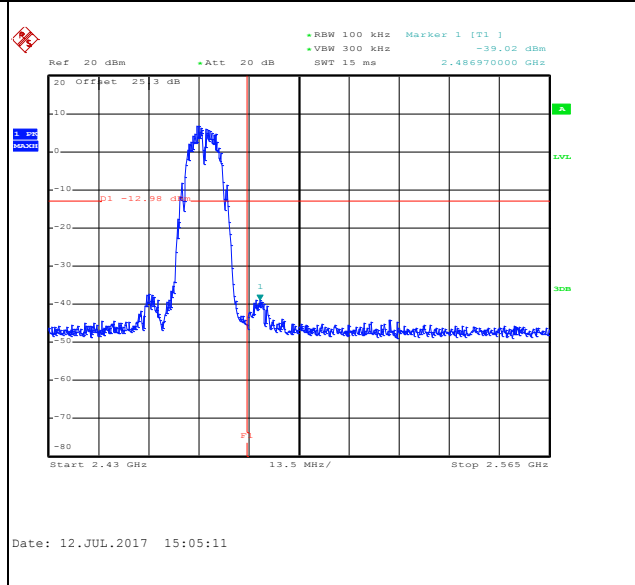

Spurious Emission 30MHz~3GHz

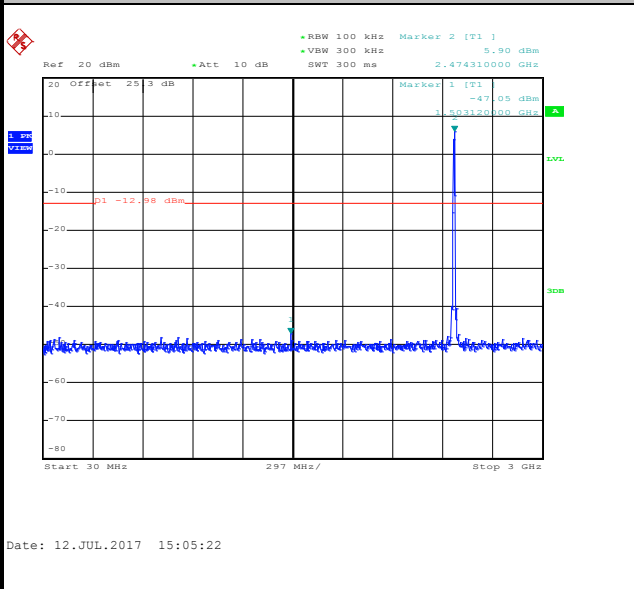

Spurious Emission 2GHz~25GHz

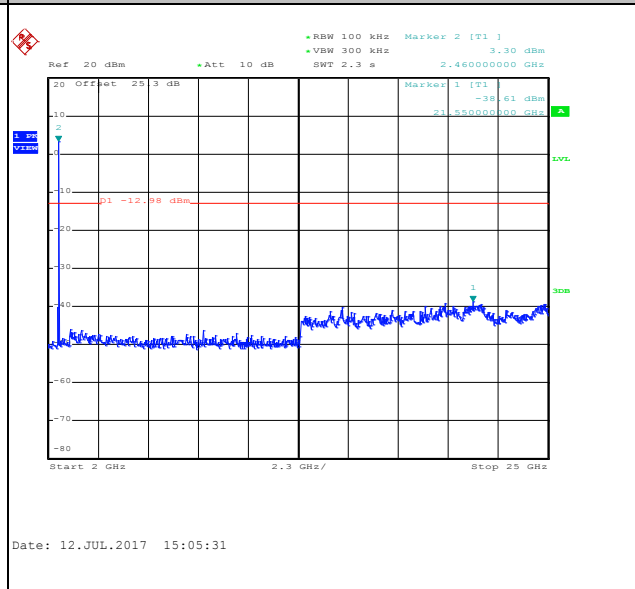



Number of TX = 1, Ant. 2 (Measured)

Number of TX :	1	Ant. :	2
Test Mode :	802.11b	Temperature :	21~25°C
Test Band :	2.4GHz Low	Relative Humidity :	51~54%
Test Channel :	01	Test Engineer :	Aking Chang

WLAN 802.11b Channel 01

100kHz PSD reference Level

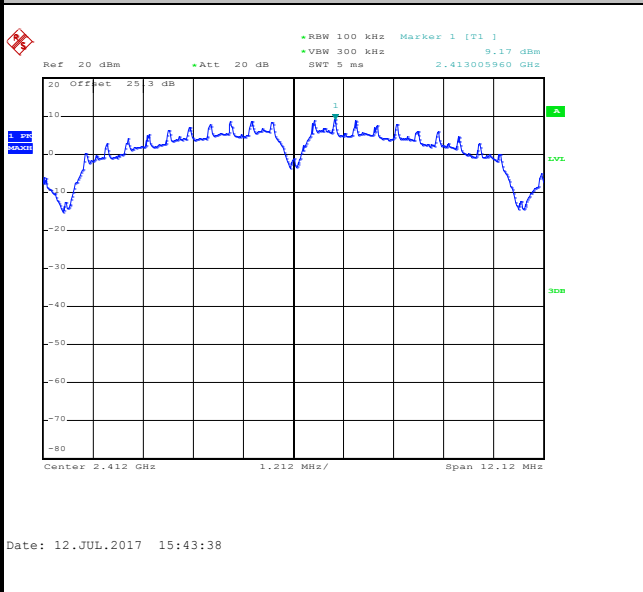

Low Channel Plot

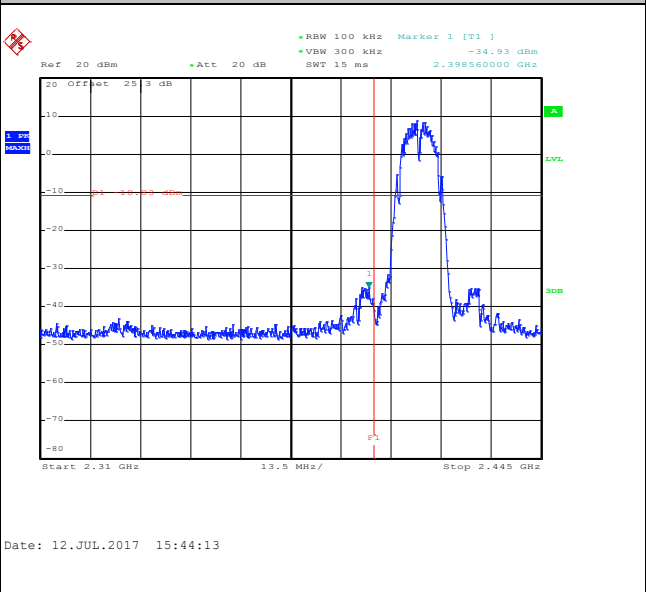

Spurious Emission 30MHz~3GHz

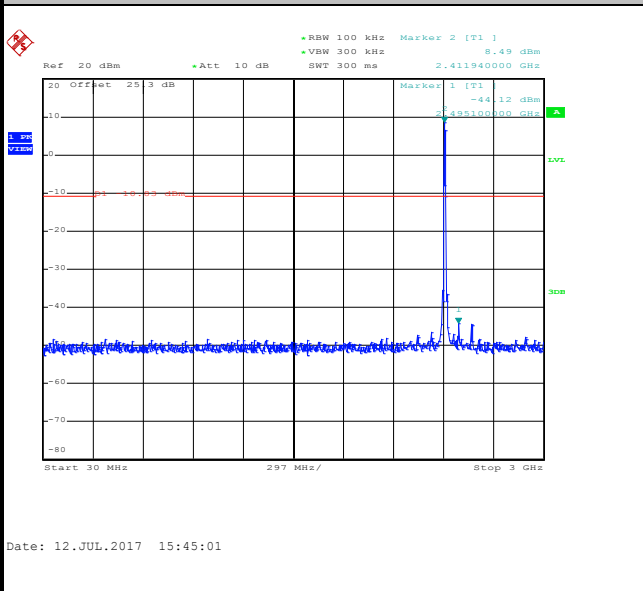

Spurious Emission 2GHz~25GHz

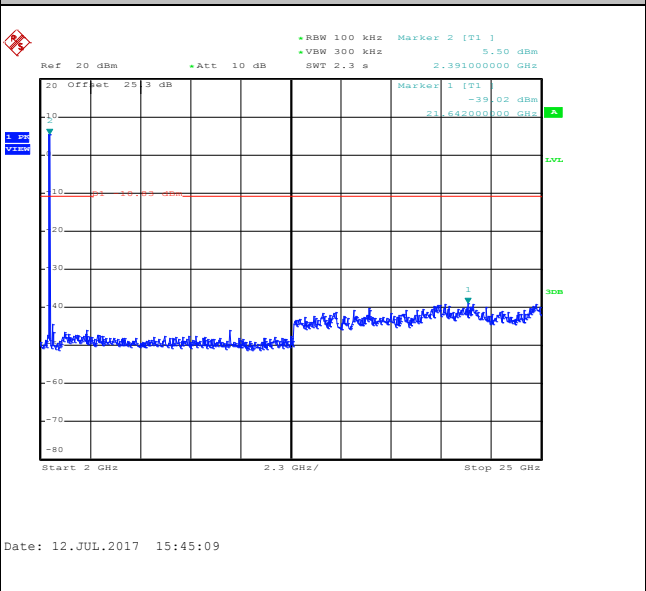



Number of TX :	1	Ant. :	2
Test Mode :	802.11b	Temperature :	21~25°C
Test Band :	2.4GHz Mid	Relative Humidity :	51~54%
Test Channel :	06	Test Engineer :	Aking Chang

WLAN 802.11b Channel 06

100kHz PSD reference Level

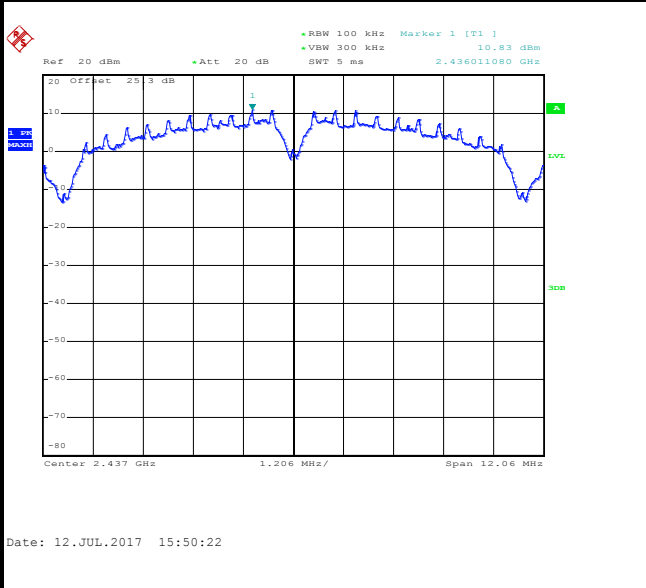

Spurious Emission 30MHz~3GHz

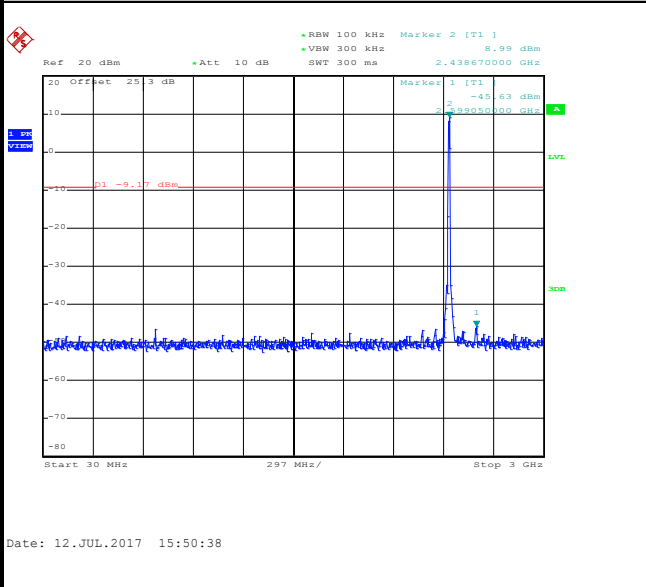

Spurious Emission 2GHz~25GHz

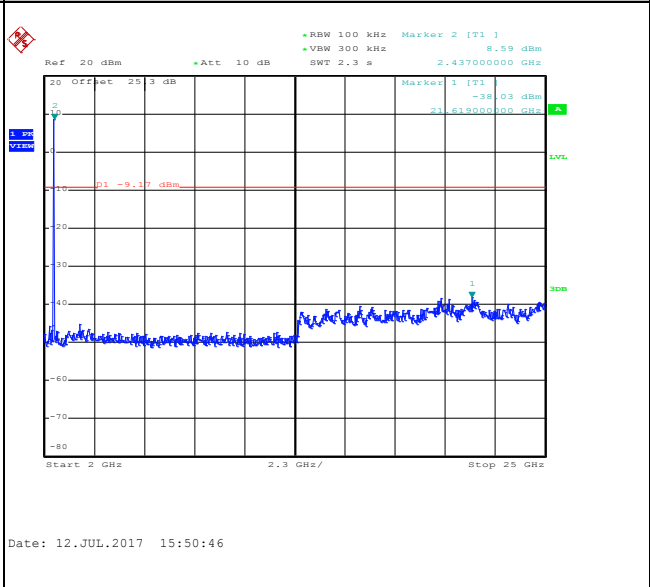



Number of TX :	1	Ant. :	2
Test Mode :	802.11b	Temperature :	21~25°C
Test Band :	2.4GHz High	Relative Humidity :	51~54%
Test Channel :	11	Test Engineer :	Aking Chang

WLAN 802.11b Channel 11

100kHz PSD reference Level

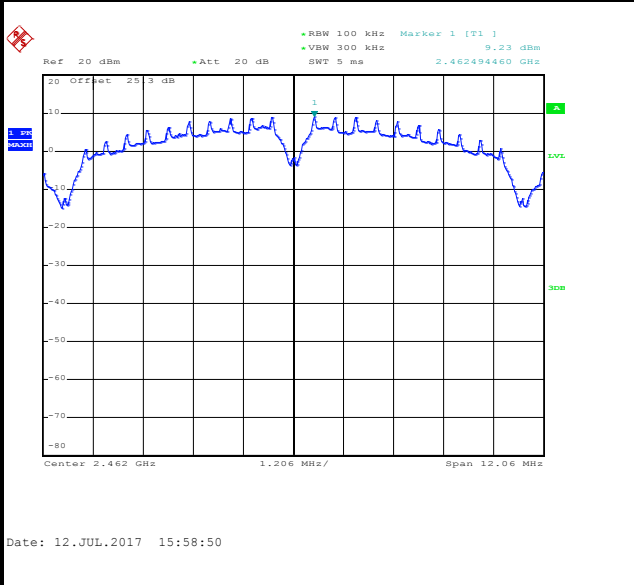

High Channel Plot

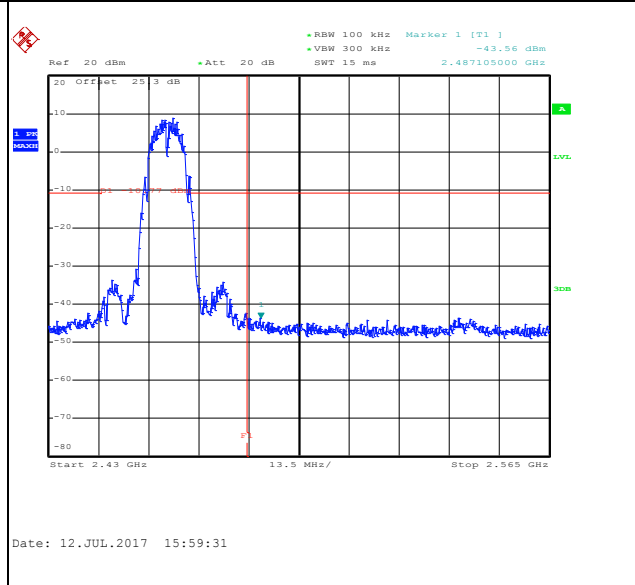

Spurious Emission 30MHz~3GHz

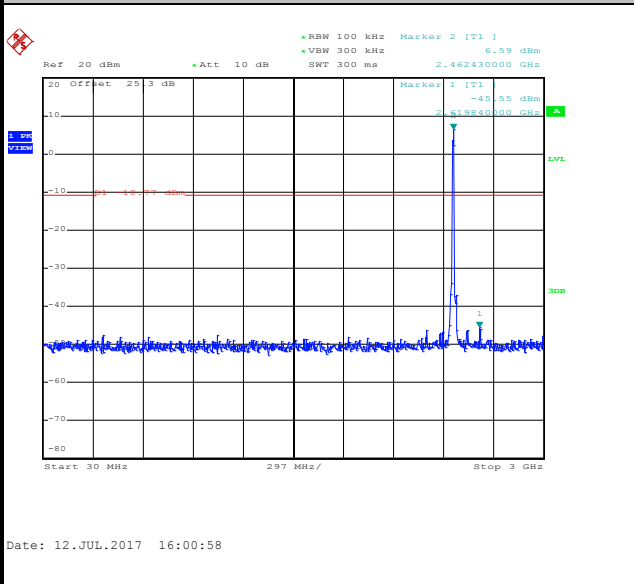

Spurious Emission 2GHz~25GHz

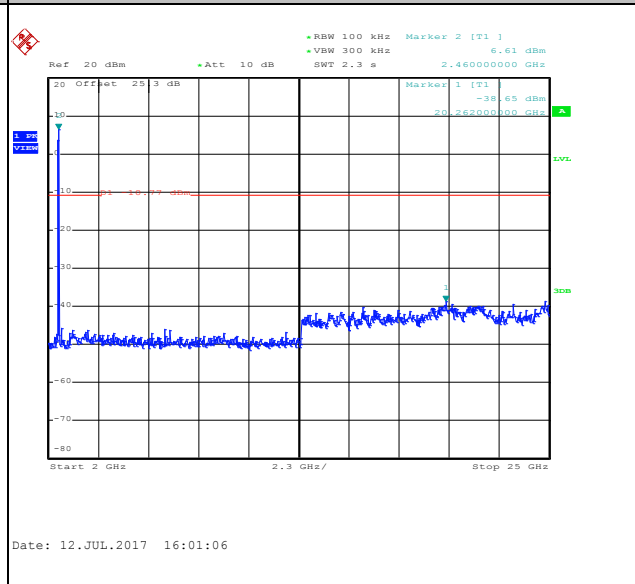



Number of TX :	1	Ant. :	2
Test Mode :	802.11b	Temperature :	21~25°C
Test Band :	2.4GHz High	Relative Humidity :	51~54%
Test Channel :	12	Test Engineer :	Aking Chang

WLAN 802.11b Channel 12

100kHz PSD reference Level

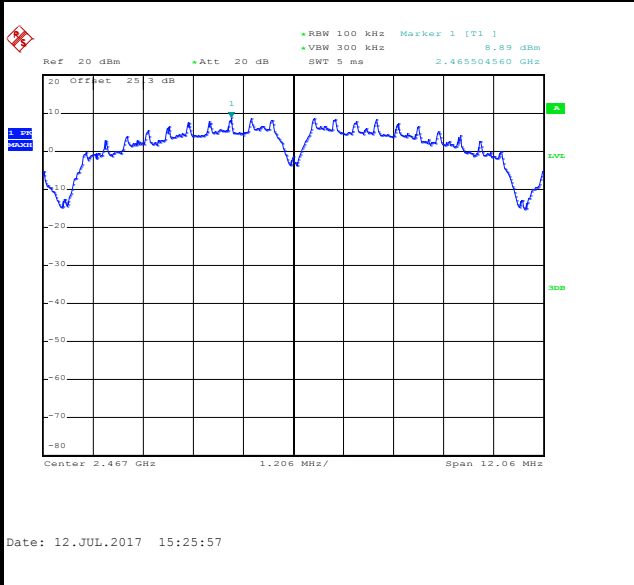

High Channel Plot

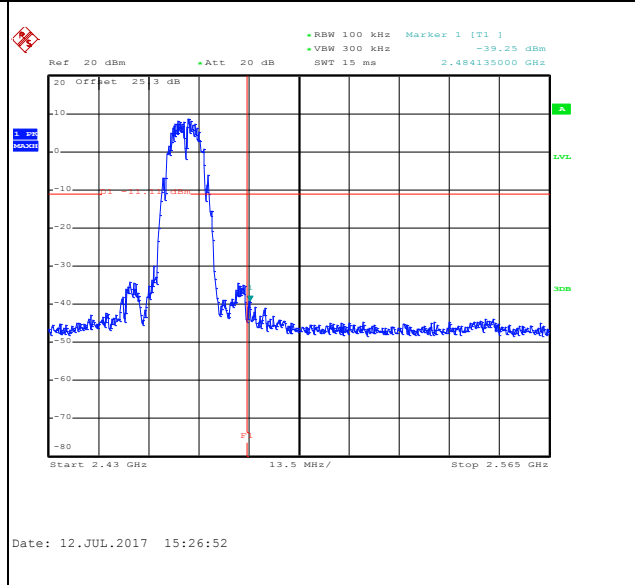

Spurious Emission 30MHz~3GHz

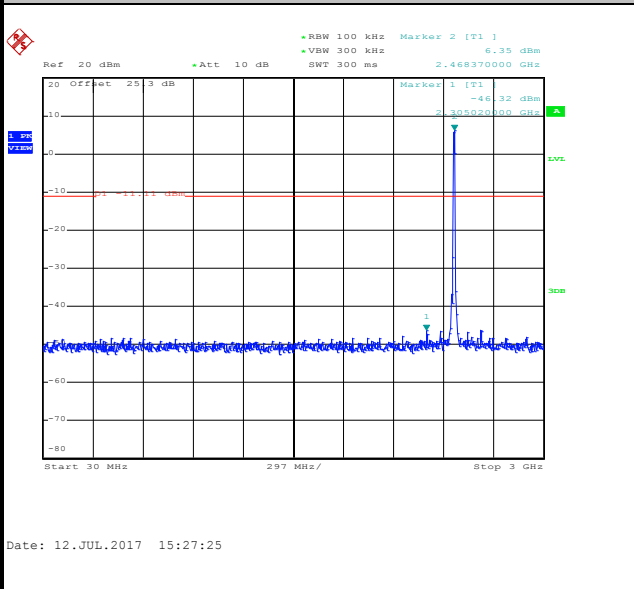

Spurious Emission 2GHz~25GHz

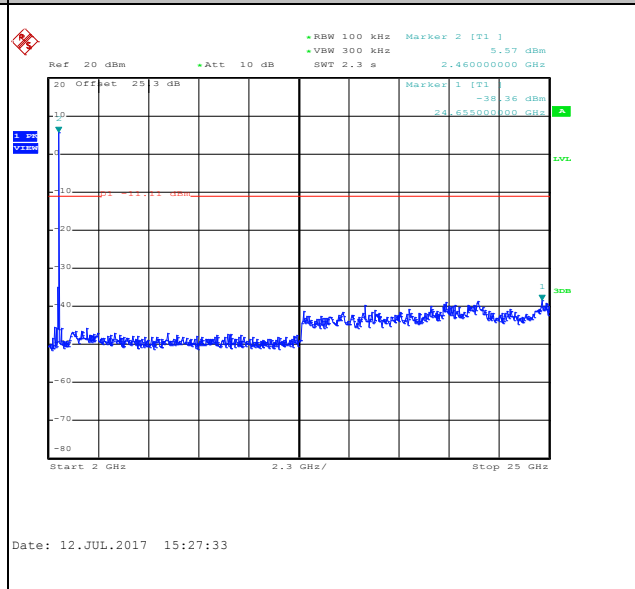



Number of TX :	1	Ant. :	2
Test Mode :	802.11b	Temperature :	21~25°C
Test Band :	2.4GHz High	Relative Humidity :	51~54%
Test Channel :	13	Test Engineer :	Aking Chang

WLAN 802.11b Channel 13

100kHz PSD reference Level

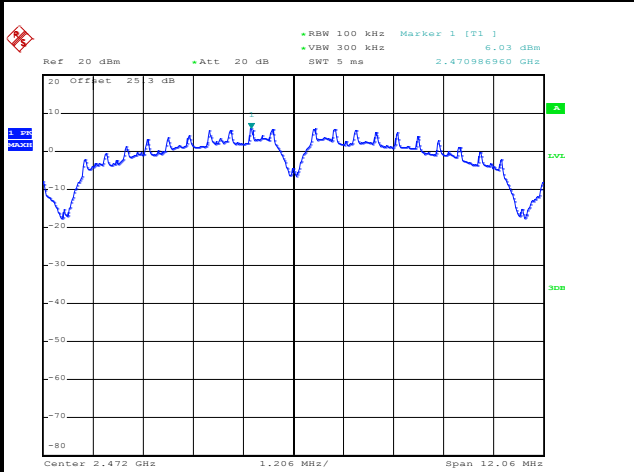

Date: 12.JUL.2017 15:14:15

High Channel Plot

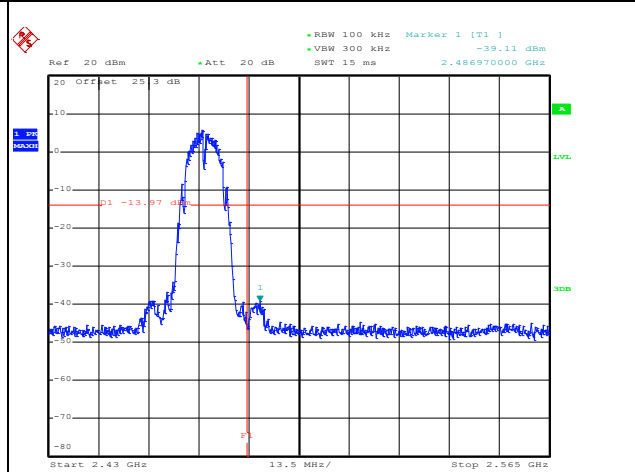

Date: 12.JUL.2017 15:14:36

Spurious Emission 30MHz~3GHz

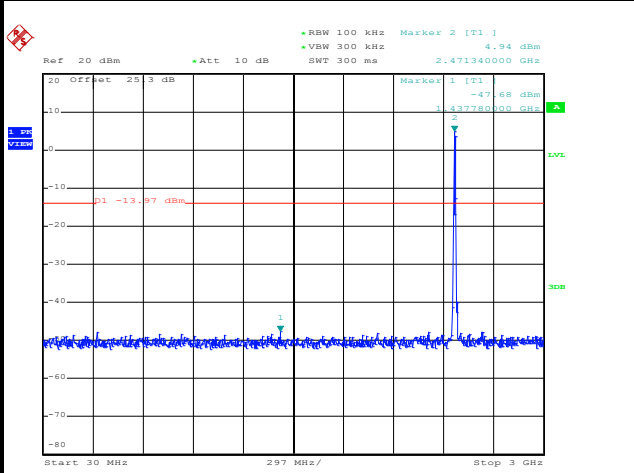

Date: 12.JUL.2017 15:15:26

Spurious Emission 2GHz~25GHz

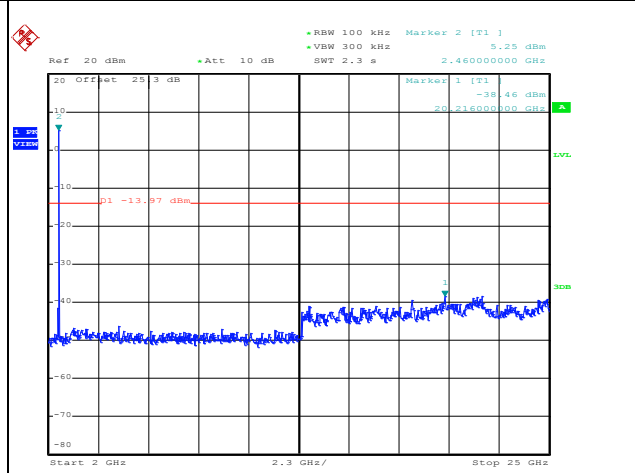

Date: 12.JUL.2017 15:15:35



Number of TX = 2, Ant. 1 (Measured)

Number of TX :	2	Ant. :	1
Test Mode :	802.11g	Temperature :	21~25°C
Test Band :	2.4GHz Low	Relative Humidity :	51~54%
Test Channel :	01	Test Engineer :	Aking Chang

WLAN 802.11g Channel 01

100kHz PSD reference Level

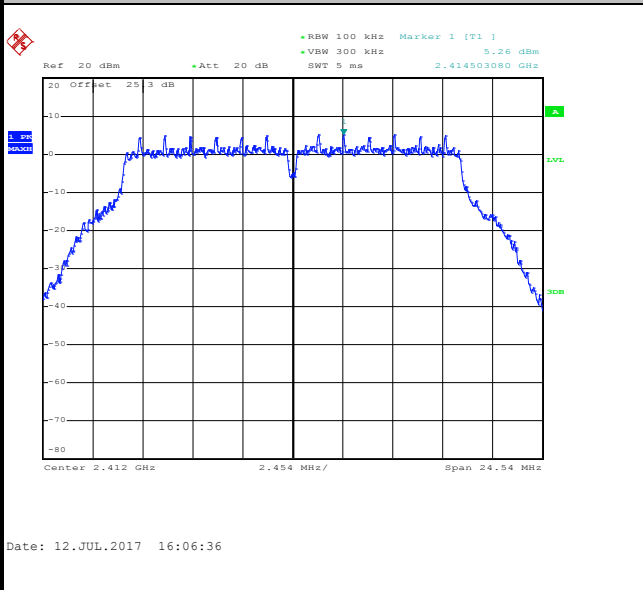

Low Channel Plot

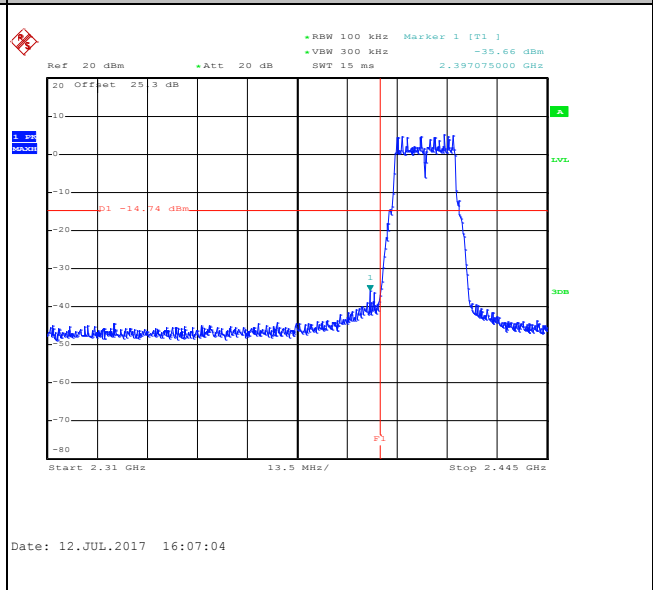

Spurious Emission 30MHz~3GHz

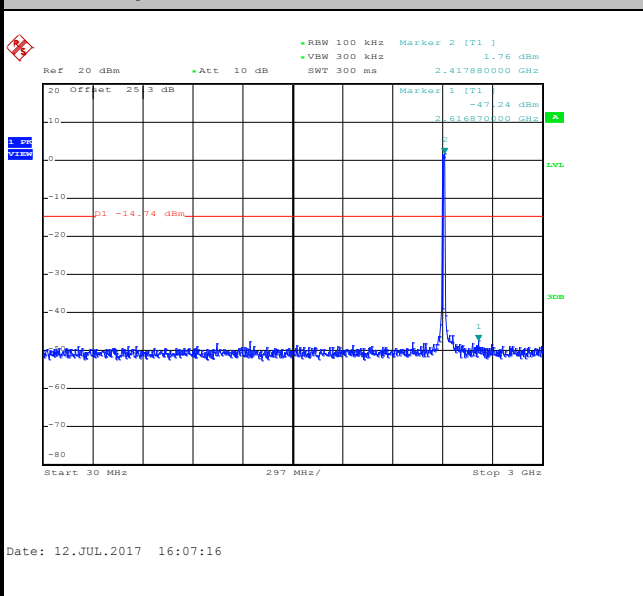

Spurious Emission 2GHz~25GHz

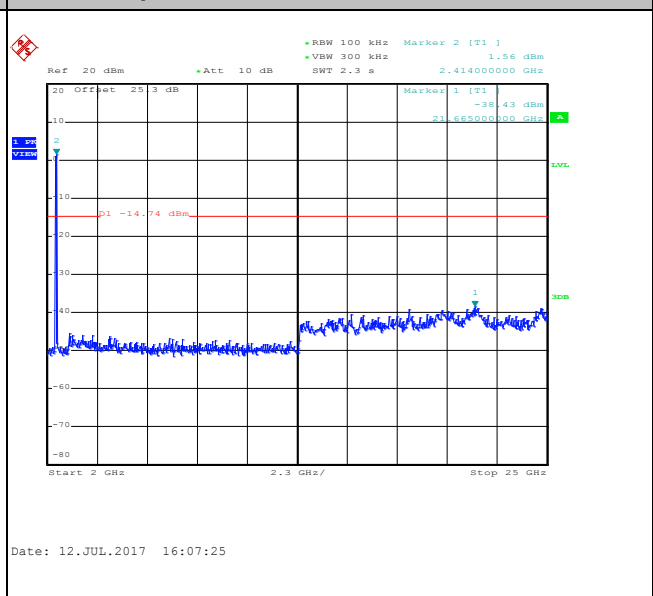



Number of TX :	2	Ant. :	1
Test Mode :	802.11g	Temperature :	21~25°C
Test Band :	2.4GHz Mid	Relative Humidity :	51~54%
Test Channel :	06	Test Engineer :	Aking Chang

WLAN 802.11g Channel 06

100kHz PSD reference Level

Mid Channel Plot

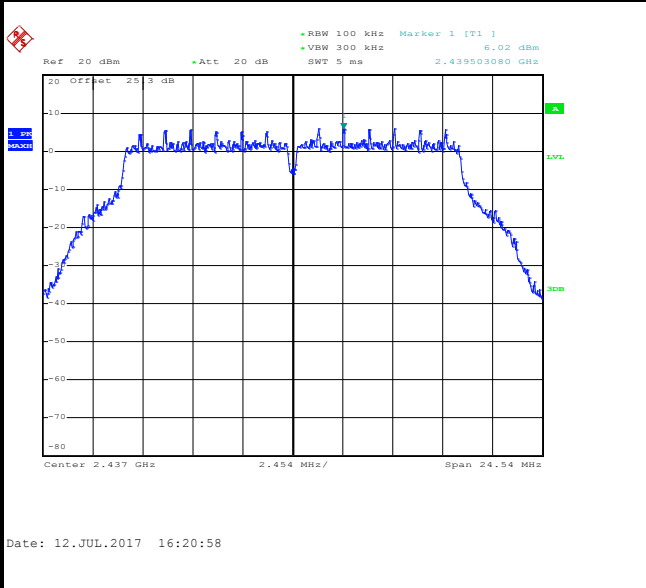

Spurious Emission 30MHz~3GHz

Spurious Emission 2GHz~25GHz

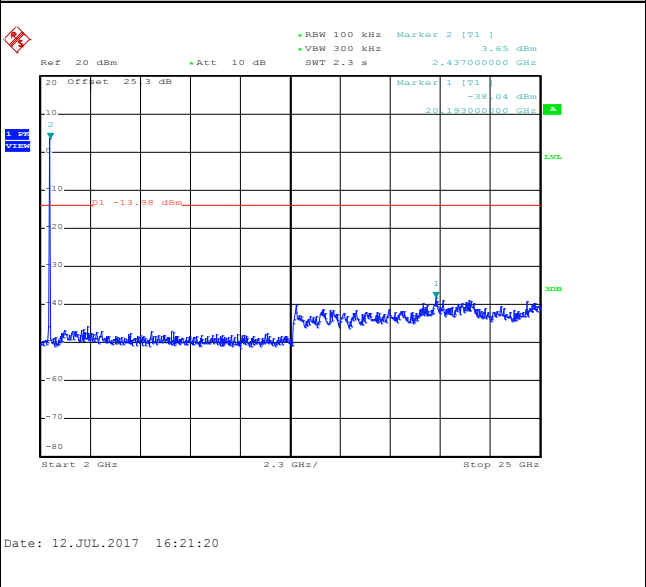
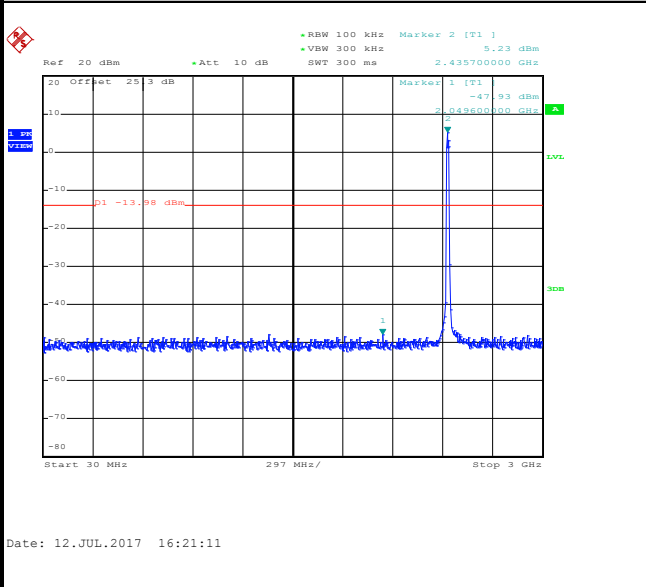



Number of TX :	2	Ant. :	1
Test Mode :	802.11g	Temperature :	21~25°C
Test Band :	2.4GHz High	Relative Humidity :	51~54%
Test Channel :	11	Test Engineer :	Aking Chang

WLAN 802.11g Channel 11

100kHz PSD reference Level

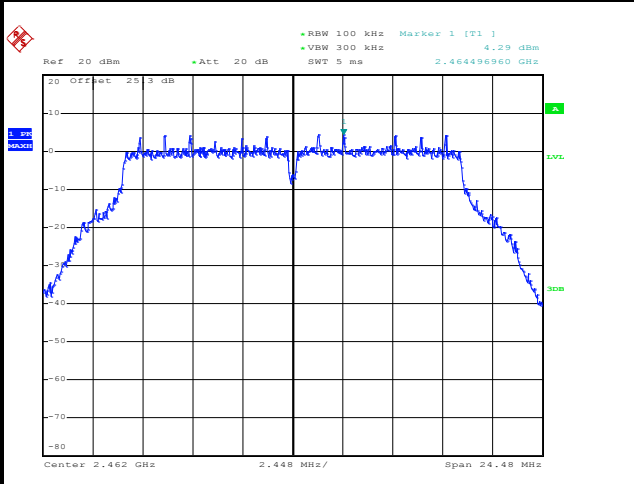

Date: 12.JUL.2017 17:28:54

High Channel Plot

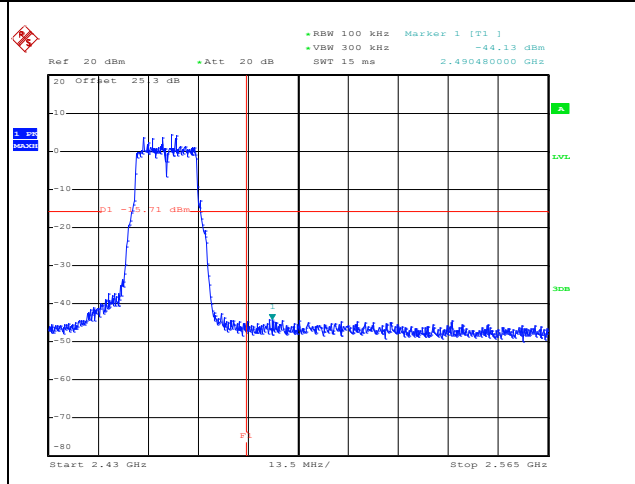

Date: 12.JUL.2017 17:29:06

Spurious Emission 30MHz~3GHz

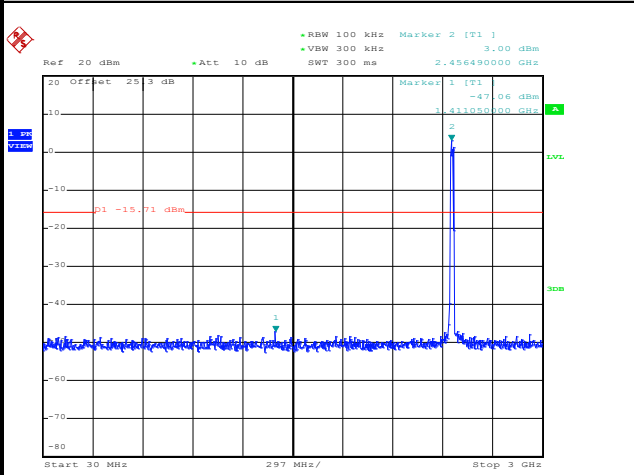

Date: 12.JUL.2017 17:29:18

Spurious Emission 2GHz~25GHz

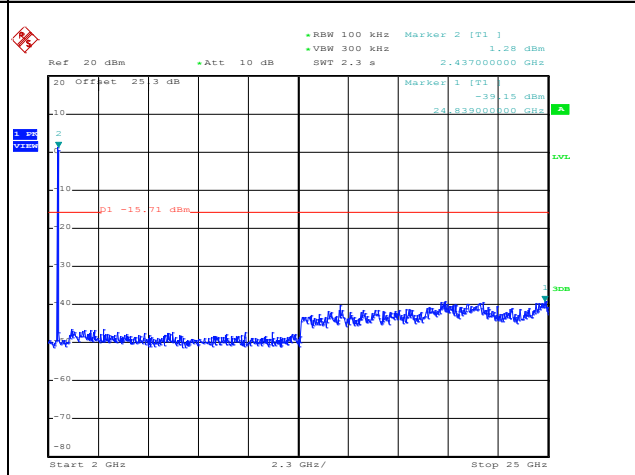

Date: 12.JUL.2017 17:29:27



Number of TX :	2	Ant. :	1
Test Mode :	802.11g	Temperature :	21~25°C
Test Band :	2.4GHz High	Relative Humidity :	51~54%
Test Channel :	12	Test Engineer :	Aking Chang

WLAN 802.11g Channel 12

100kHz PSD reference Level

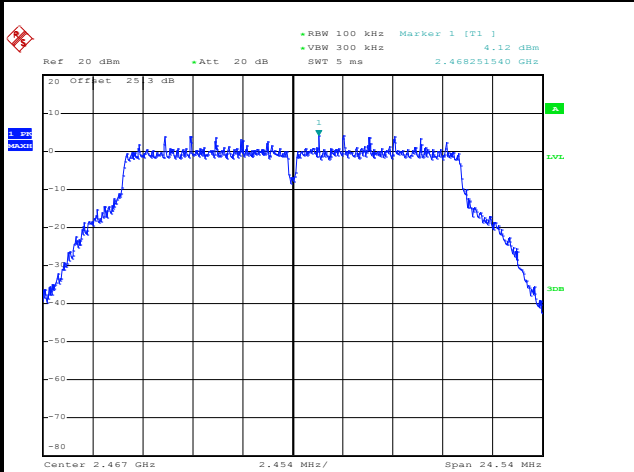

Date: 12.JUL.2017 17:49:18

High Channel Plot

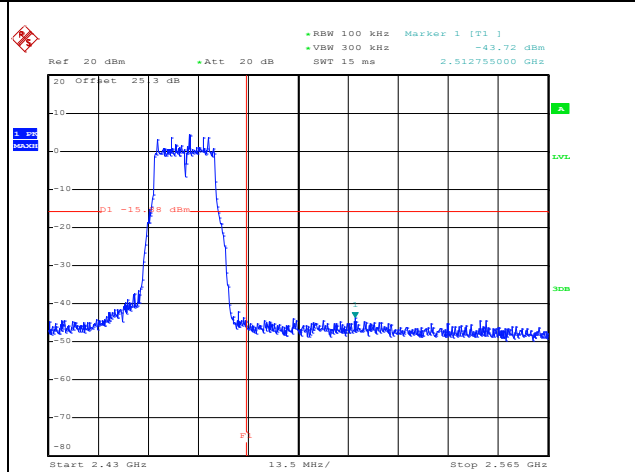

Date: 12.JUL.2017 17:49:32

Spurious Emission 30MHz~3GHz

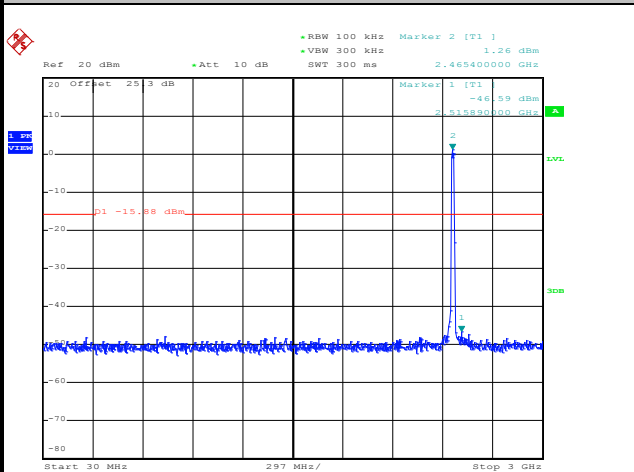

Date: 12.JUL.2017 17:50:20

Spurious Emission 2GHz~25GHz

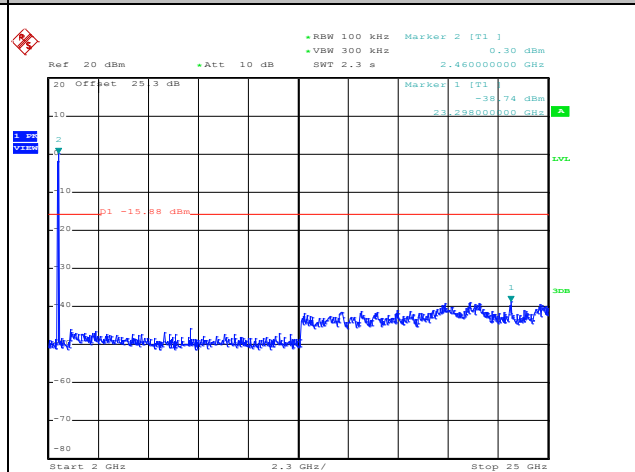

Date: 12.JUL.2017 17:50:29



Number of TX :	2	Ant. :	1
Test Mode :	802.11g	Temperature :	21~25°C
Test Band :	2.4GHz High	Relative Humidity :	51~54%
Test Channel :	13	Test Engineer :	Aking Chang

WLAN 802.11g Channel 13

100kHz PSD reference Level

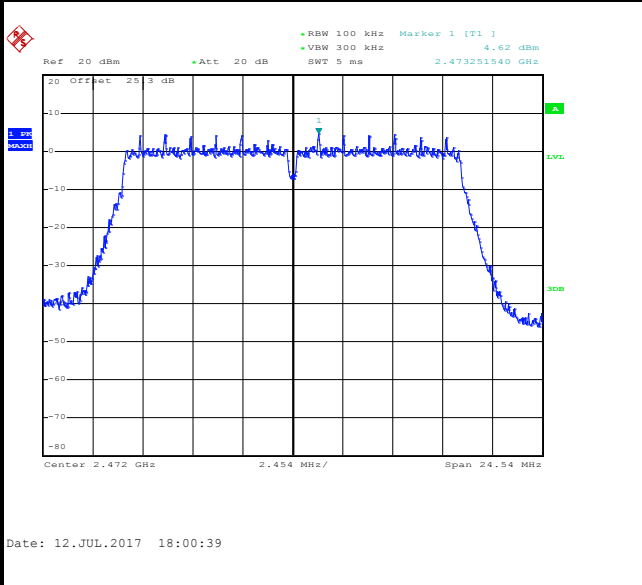

High Channel Plot

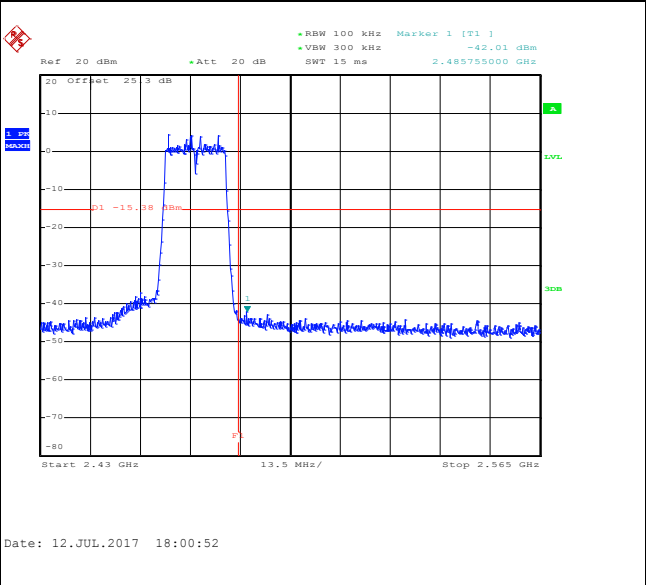

Spurious Emission 30MHz~3GHz

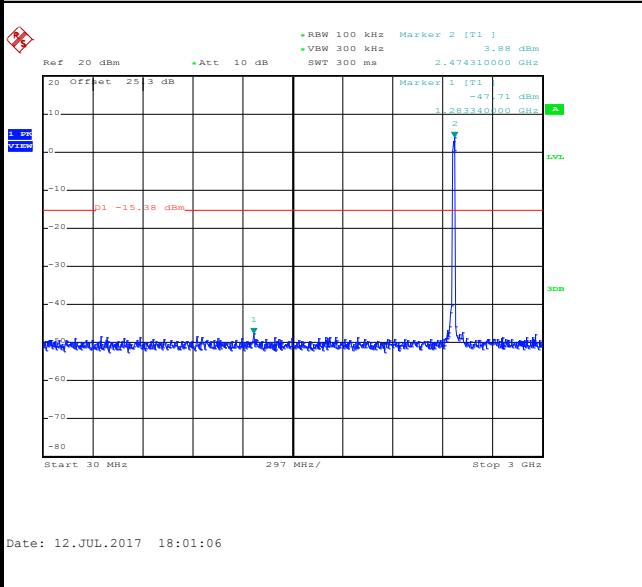

Spurious Emission 2GHz~25GHz

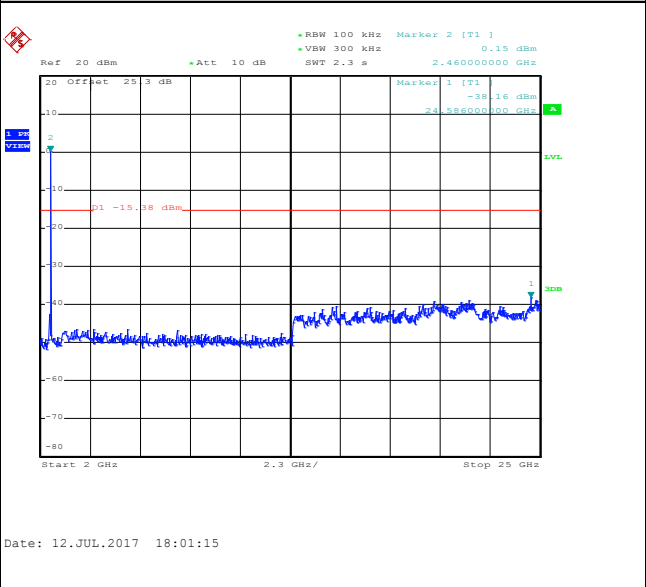



Number of TX :	2	Ant. :	1
Test Mode :	802.11n HT20	Temperature :	21~25°C
Test Band :	2.4GHz Low	Relative Humidity :	51~54%
Test Channel :	01	Test Engineer :	Aking Chang

WLAN 802.11n HT20 Channel 01

100kHz PSD reference Level

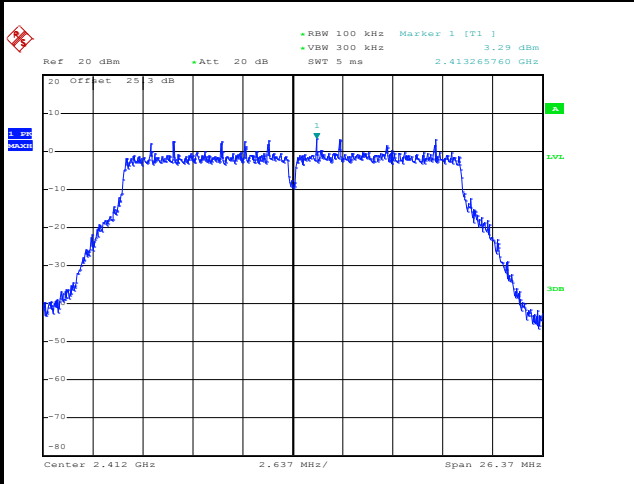

Date: 12.JUL.2017 18:45:05

Low Channel Plot

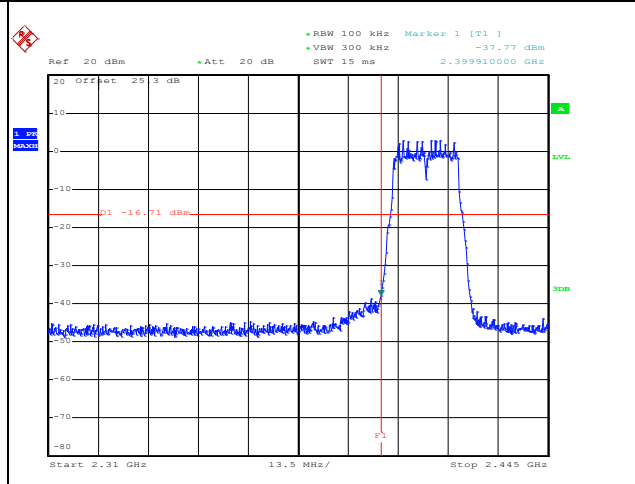

Date: 12.JUL.2017 18:45:17

Spurious Emission 30MHz~3GHz

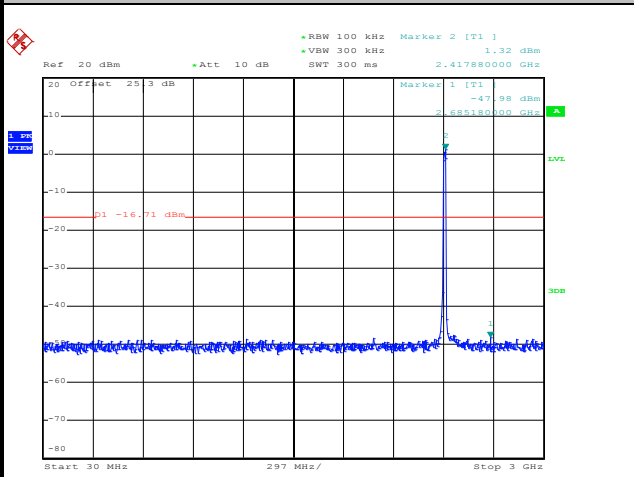

Date: 12.JUL.2017 18:45:52

Spurious Emission 2GHz~25GHz

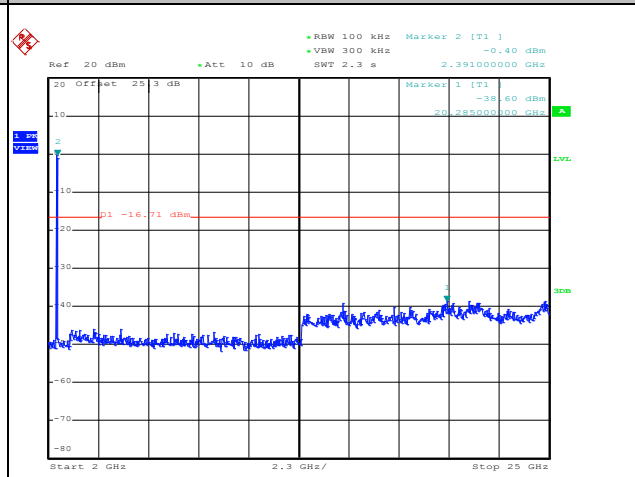

Date: 12.JUL.2017 18:46:00



Number of TX :	2	Ant. :	1
Test Mode :	802.11n HT20	Temperature :	21~25°C
Test Band :	2.4GHz Mid	Relative Humidity :	51~54%
Test Channel :	06	Test Engineer :	Aking Chang

WLAN 802.11n HT20 Channel 06

100kHz PSD reference Level

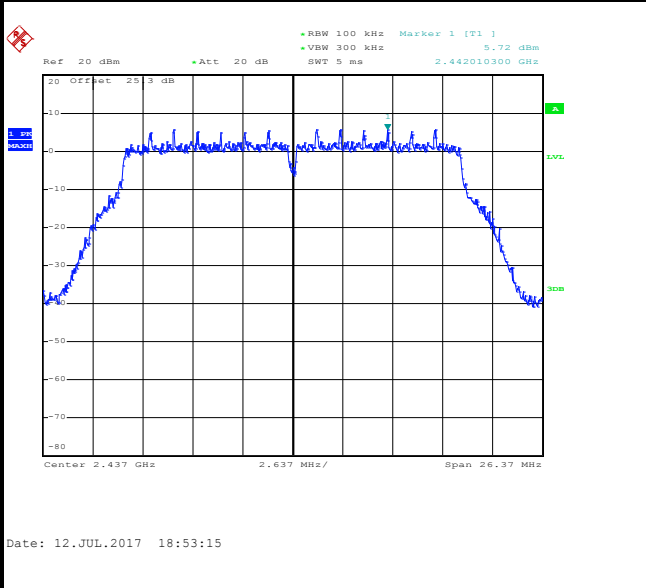

Spurious Emission 30MHz~3GHz

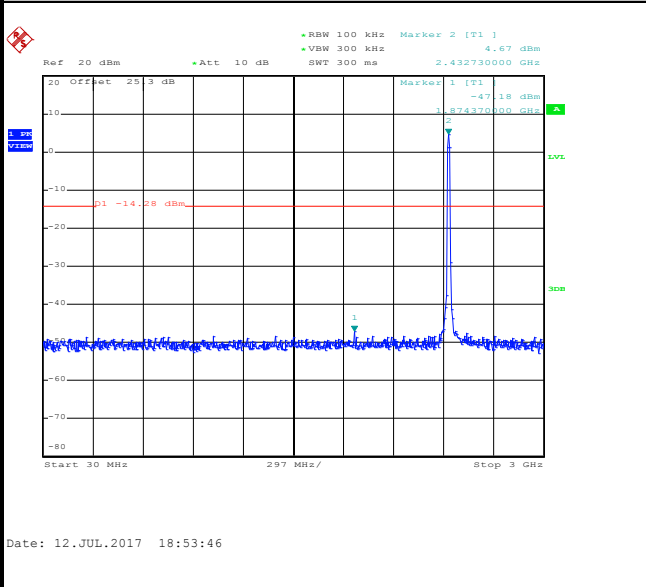

Spurious Emission 2GHz~25GHz

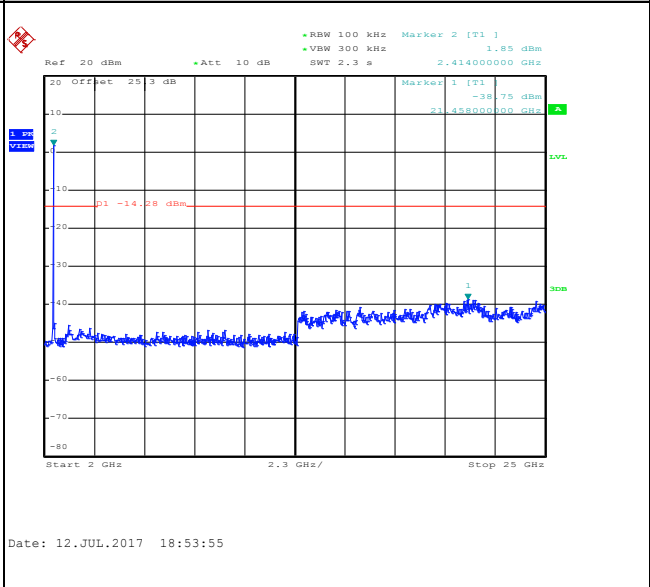



Number of TX :	2	Ant. :	1
Test Mode :	802.11n HT20	Temperature :	21~25°C
Test Band :	2.4GHz High	Relative Humidity :	51~54%
Test Channel :	11	Test Engineer :	Aking Chang

WLAN 802.11n HT20 Channel 11

100kHz PSD reference Level

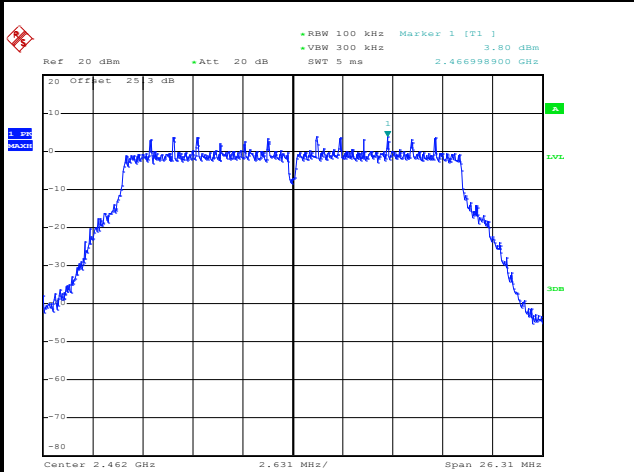

Date: 12.JUL.2017 18:58:28

High Channel Plot

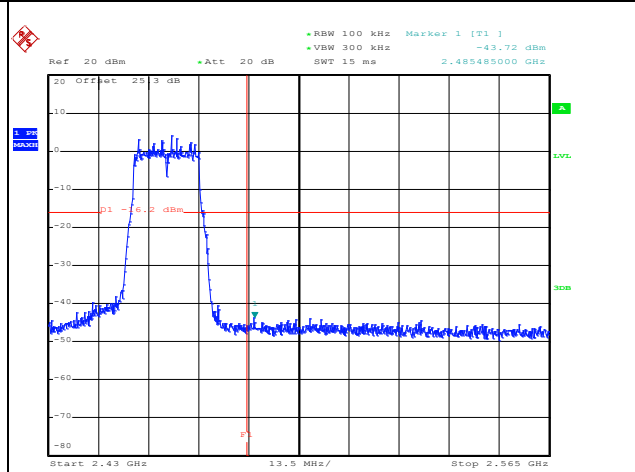

Date: 12.JUL.2017 18:58:38

Spurious Emission 30MHz~3GHz

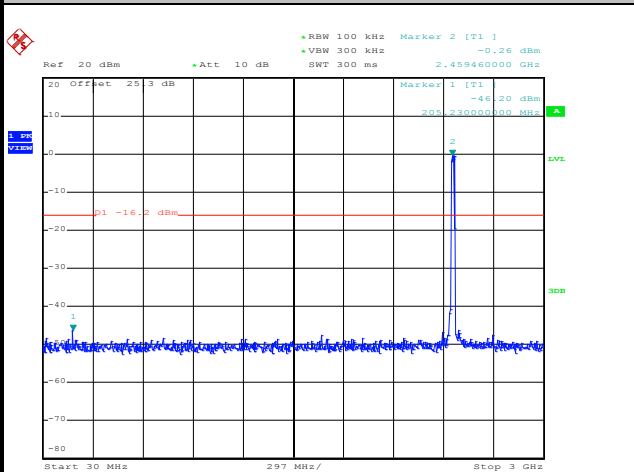

Date: 12.JUL.2017 18:58:51

Spurious Emission 2GHz~25GHz

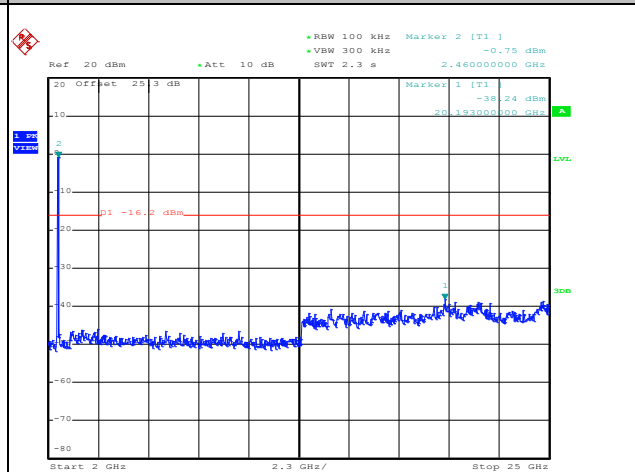

Date: 12.JUL.2017 18:58:59



Number of TX :	2	Ant. :	1
Test Mode :	802.11n HT20	Temperature :	21~25°C
Test Band :	2.4GHz High	Relative Humidity :	51~54%
Test Channel :	12	Test Engineer :	Aking Chang

WLAN 802.11n HT20 Channel 12

100kHz PSD reference Level



High Channel Plot

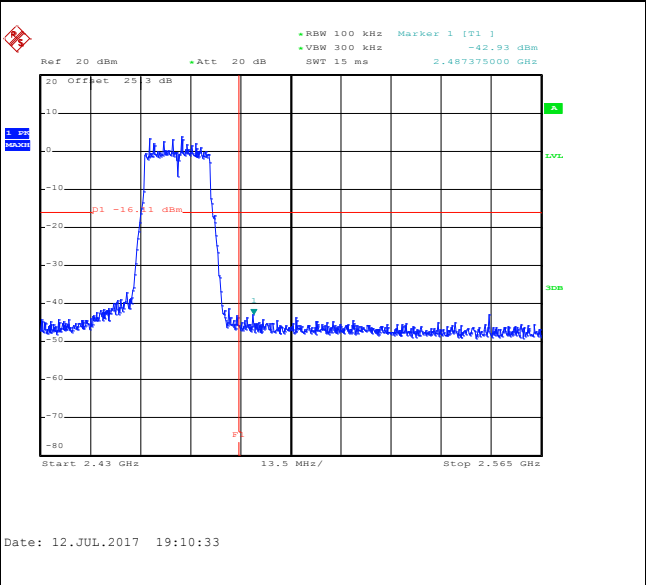

Spurious Emission 30MHz~3GHz

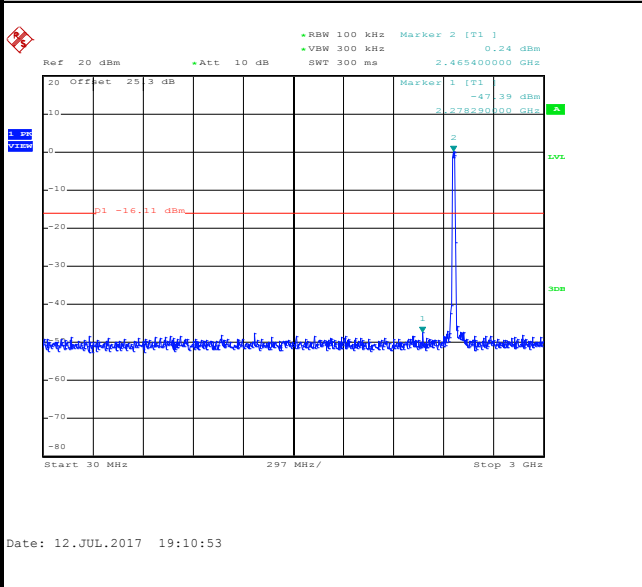

Spurious Emission 2GHz~25GHz

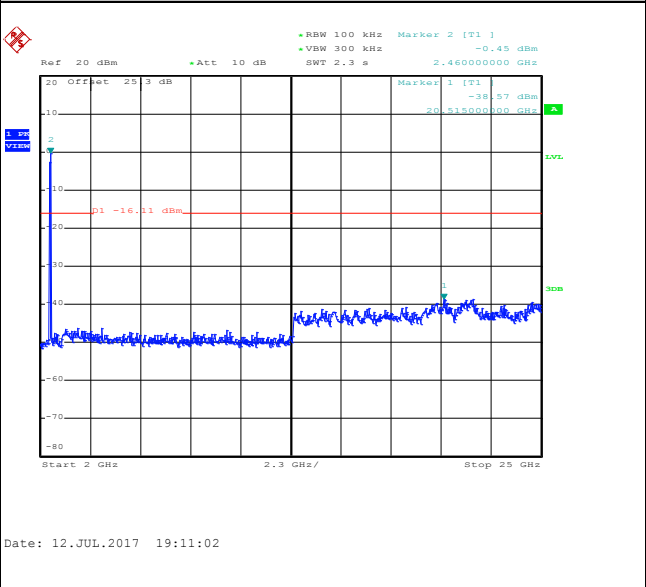



Number of TX :	2	Ant. :	1
Test Mode :	802.11n HT20	Temperature :	21~25°C
Test Band :	2.4GHz High	Relative Humidity :	51~54%
Test Channel :	13	Test Engineer :	Aking Chang

WLAN 802.11n HT20 Channel 13

100kHz PSD reference Level

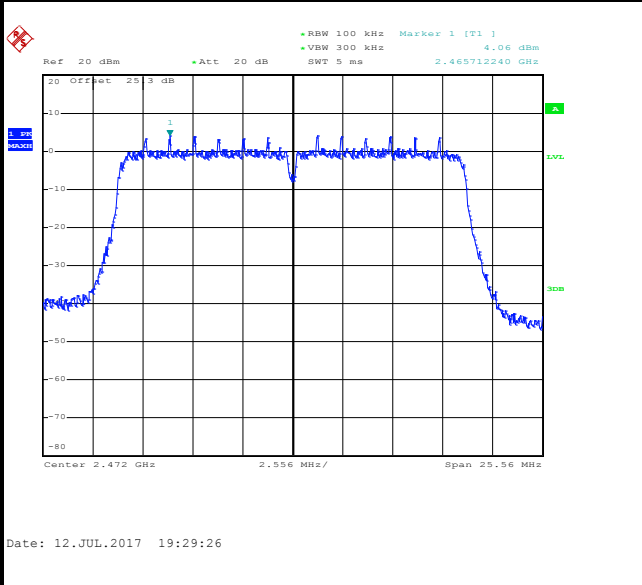

High Channel Plot

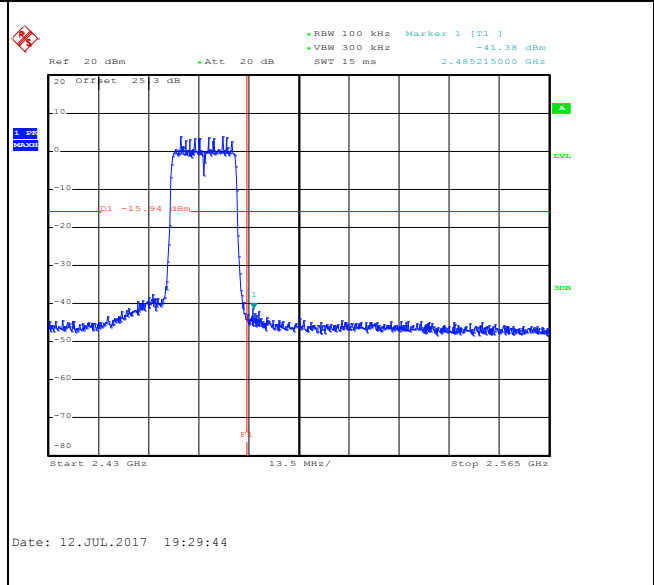

Spurious Emission 30MHz~3GHz

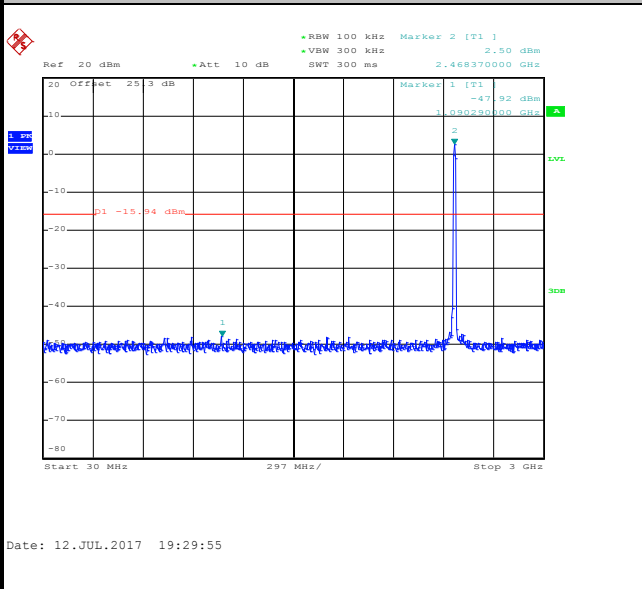

Spurious Emission 2GHz~25GHz

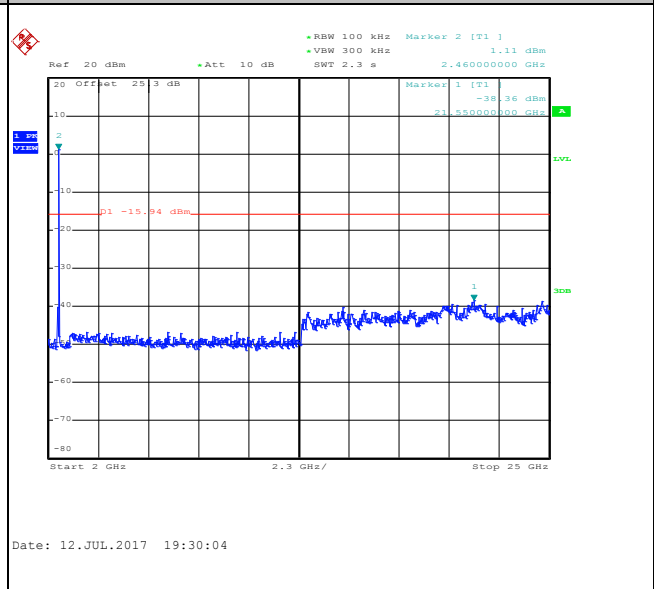



Number of TX = 2, Ant. 2 (Measured)

Number of TX :	2	Ant. :	2
Test Mode :	802.11g	Temperature :	21~25°C
Test Band :	2.4GHz Low	Relative Humidity :	51~54%
Test Channel :	01	Test Engineer :	Aking Chang

WLAN 802.11g Channel 01

100kHz PSD reference Level

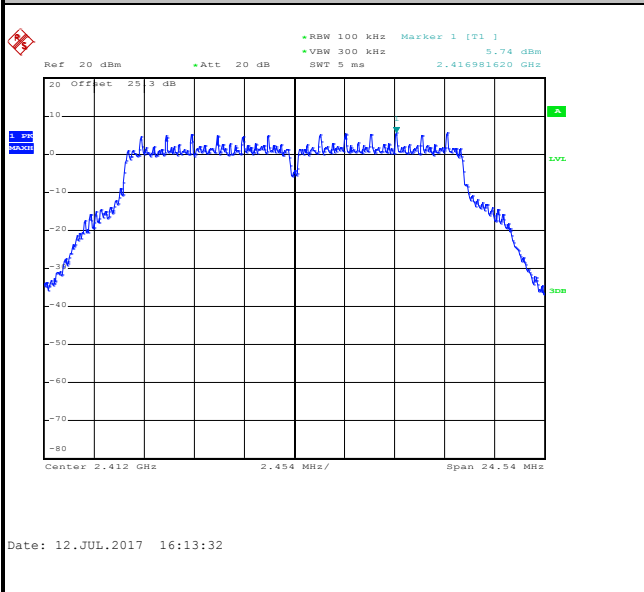

Low Channel Plot

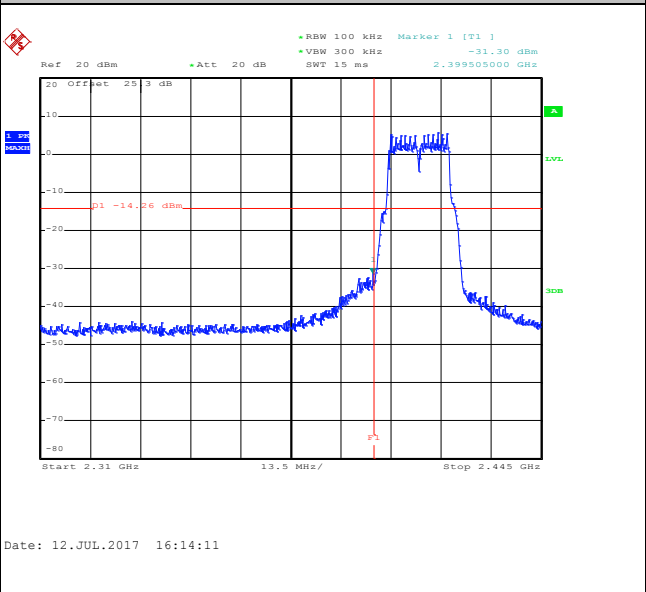

Spurious Emission 30MHz~3GHz

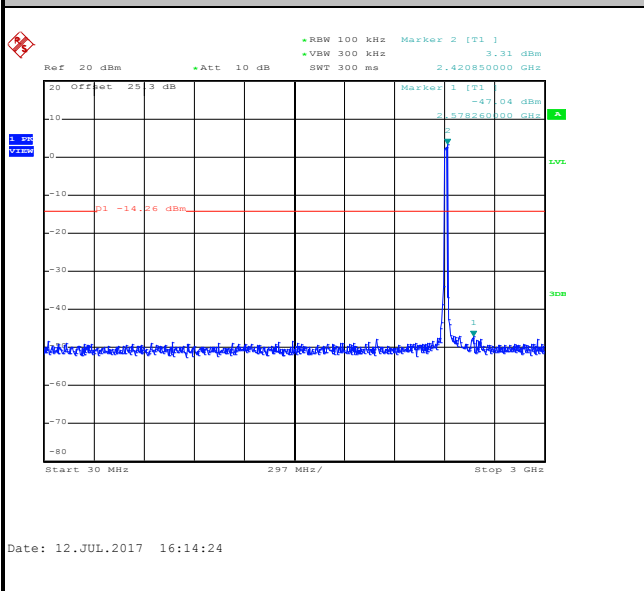

Spurious Emission 2GHz~25GHz

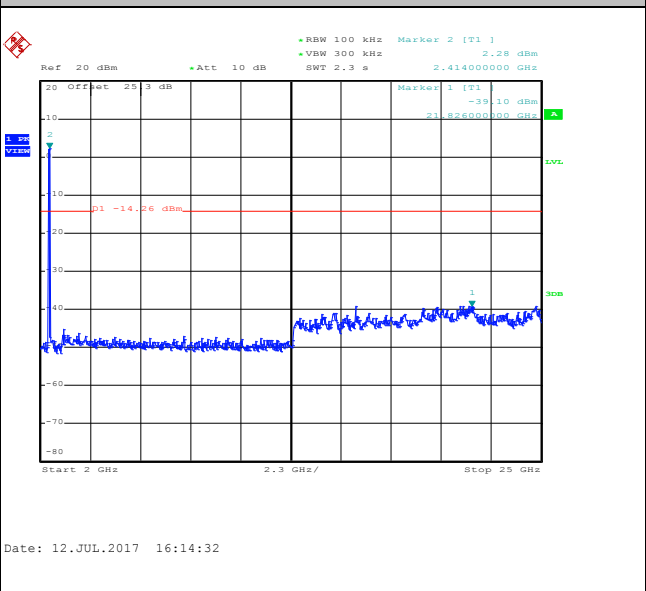



Number of TX :	2	Ant. :	2
Test Mode :	802.11g	Temperature :	21~25°C
Test Band :	2.4GHz Mid	Relative Humidity :	51~54%
Test Channel :	06	Test Engineer :	Aking Chang

WLAN 802.11g Channel 06

100kHz PSD reference Level

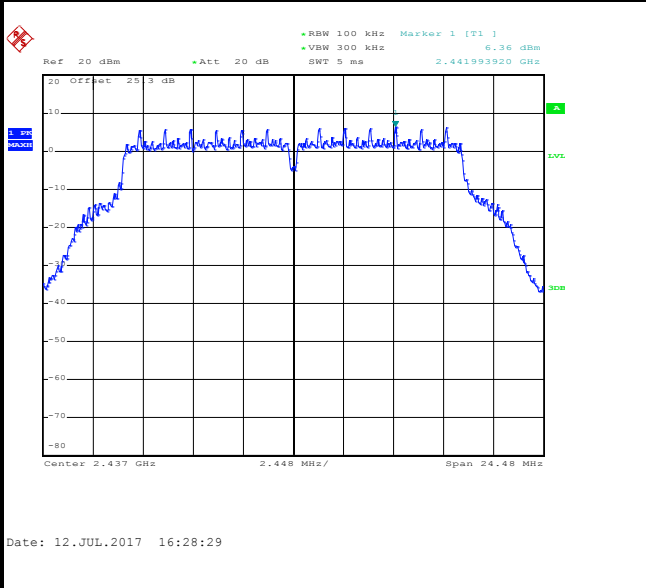

Spurious Emission 30MHz~3GHz

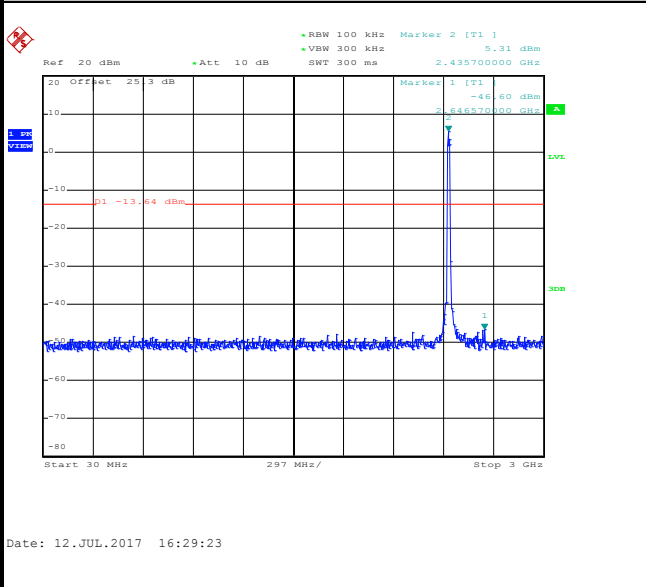

Spurious Emission 2GHz~25GHz

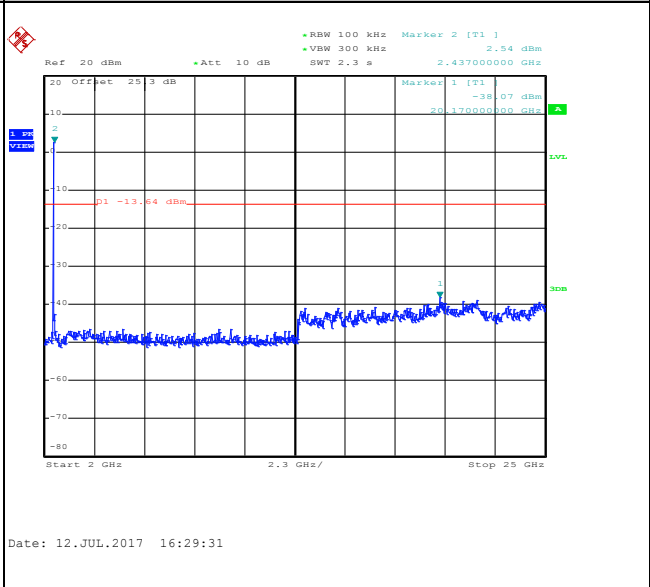



Number of TX :	2	Ant. :	2
Test Mode :	802.11g	Temperature :	21~25°C
Test Band :	2.4GHz High	Relative Humidity :	51~54%
Test Channel :	11	Test Engineer :	Aking Chang

WLAN 802.11g Channel 11

100kHz PSD reference Level

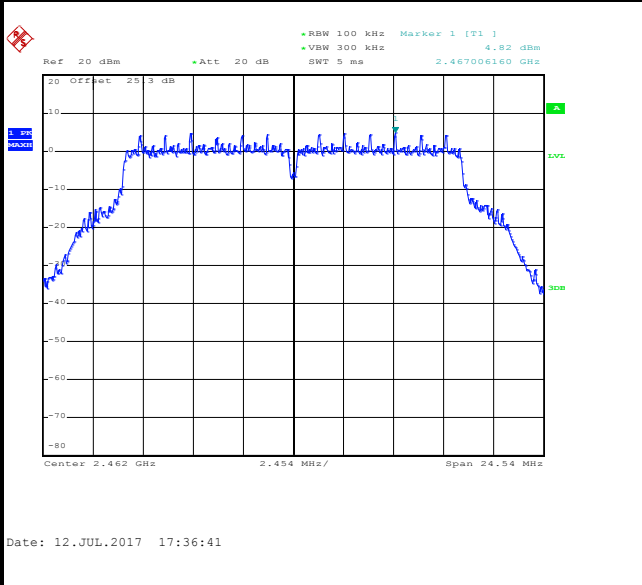

High Channel Plot

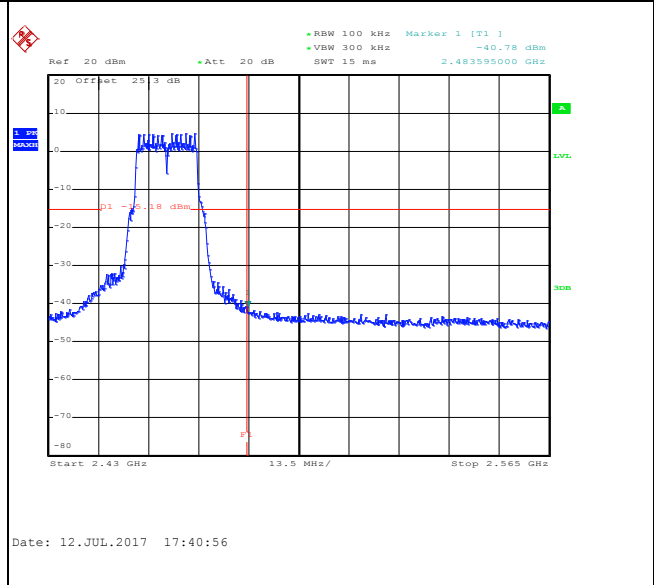

Spurious Emission 30MHz~3GHz

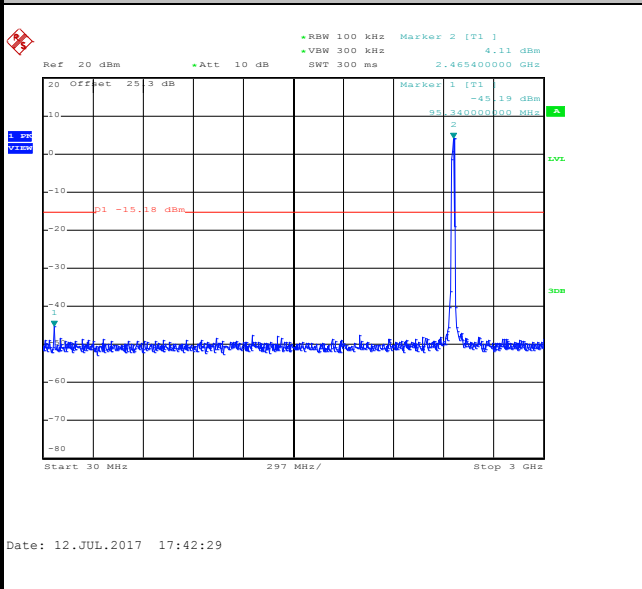

Spurious Emission 2GHz~25GHz

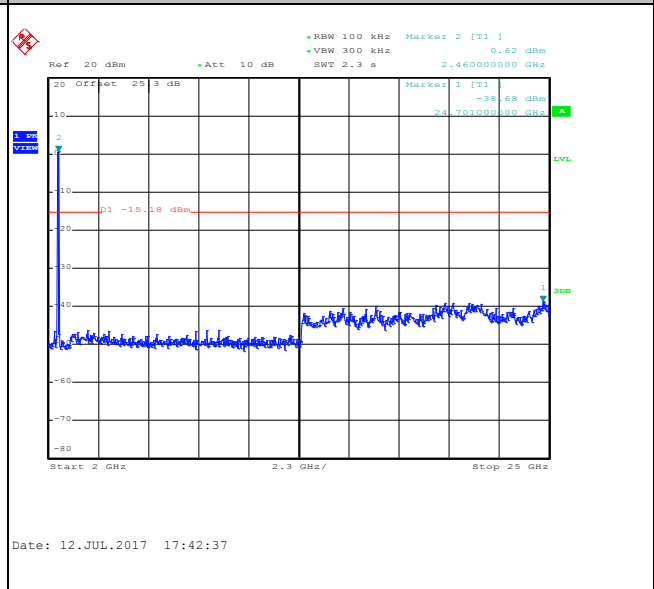



Number of TX :	2	Ant. :	2
Test Mode :	802.11g	Temperature :	21~25°C
Test Band :	2.4GHz High	Relative Humidity :	51~54%
Test Channel :	12	Test Engineer :	Aking Chang

WLAN 802.11g Channel 12

100kHz PSD reference Level

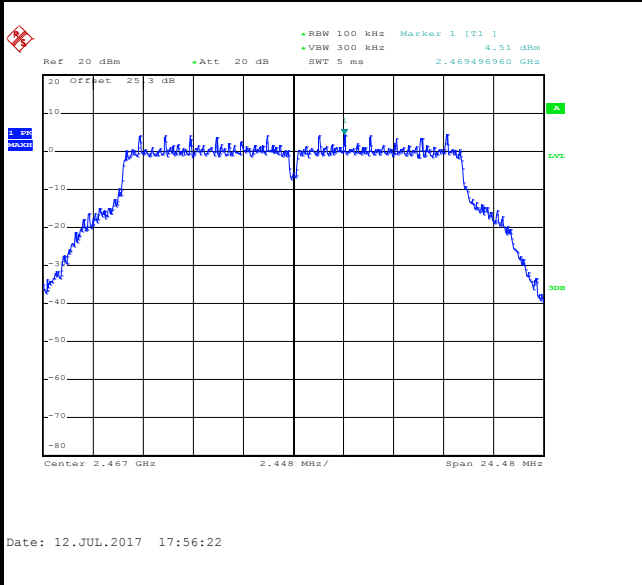

High Channel Plot

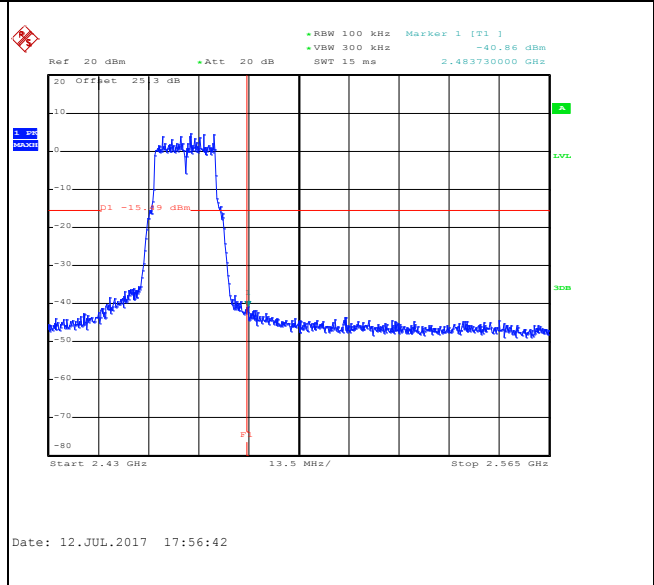

Spurious Emission 30MHz~3GHz

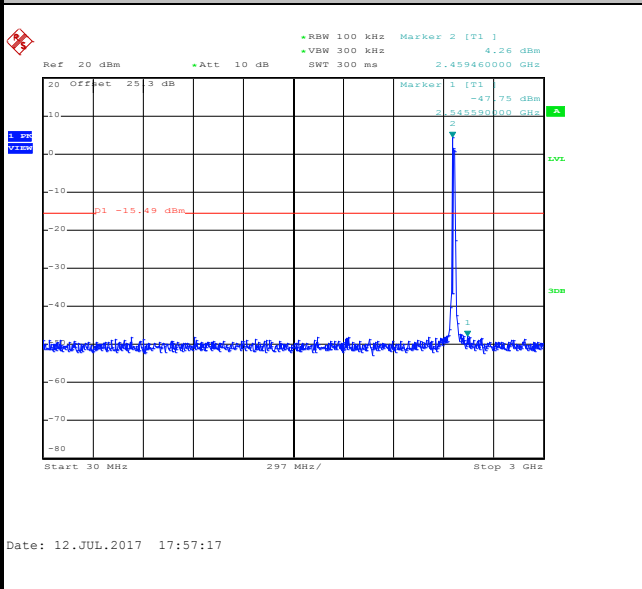

Spurious Emission 2GHz~25GHz

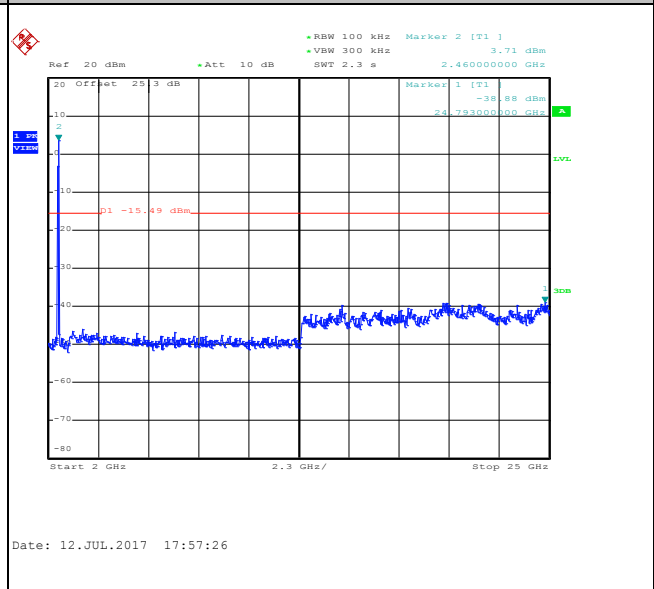



Number of TX :	2	Ant. :	2
Test Mode :	802.11g	Temperature :	21~25°C
Test Band :	2.4GHz High	Relative Humidity :	51~54%
Test Channel :	13	Test Engineer :	Aking Chang

WLAN 802.11g Channel 13

100kHz PSD reference Level

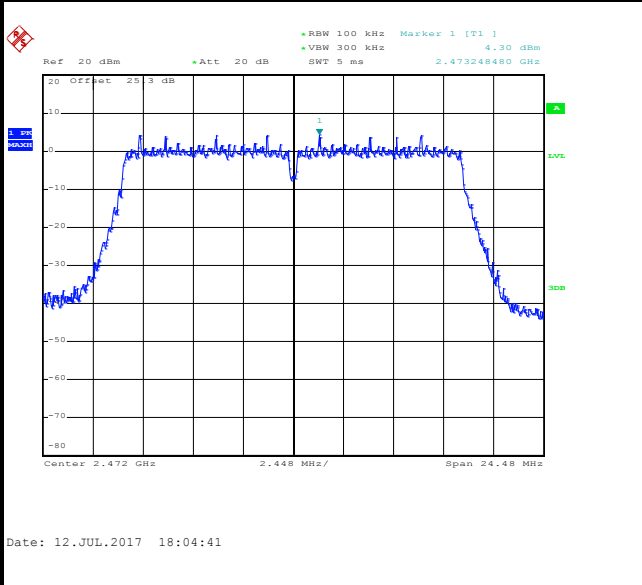

High Channel Plot

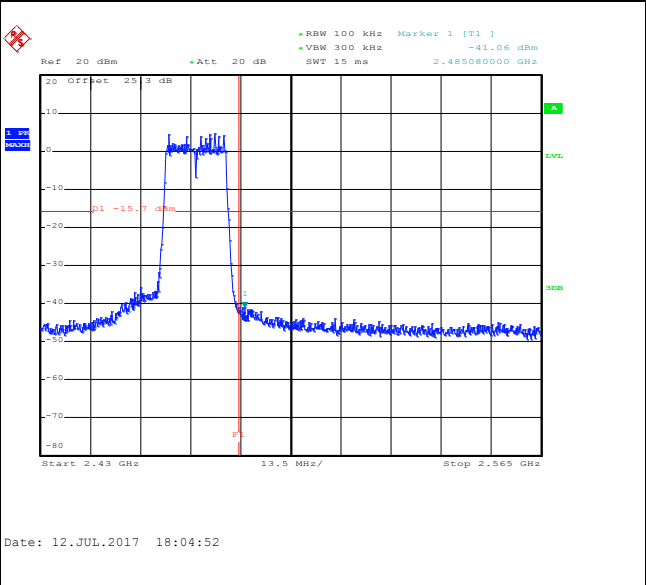

Spurious Emission 30MHz~3GHz

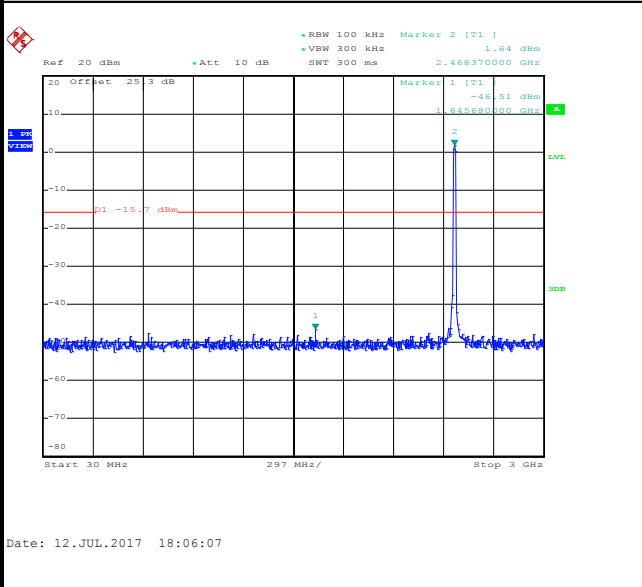

Spurious Emission 2GHz~25GHz

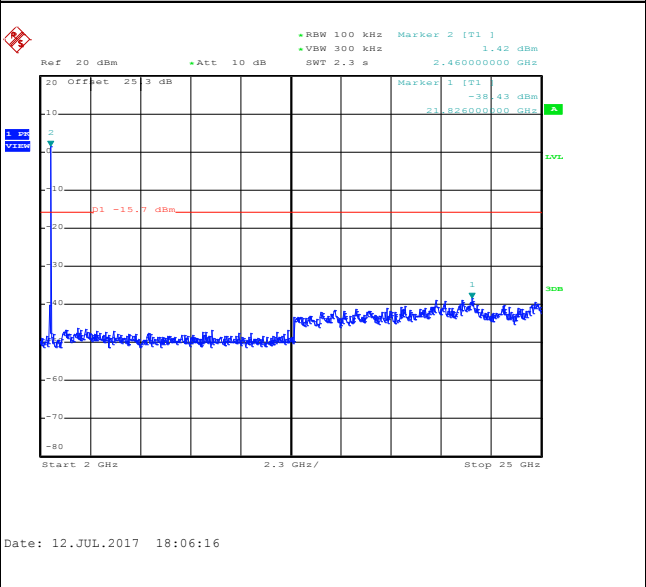



Number of TX :	2	Ant. :	2
Test Mode :	802.11n HT20	Temperature :	21~25°C
Test Band :	2.4GHz Low	Relative Humidity :	51~54%
Test Channel :	01	Test Engineer :	Aking Chang

WLAN 802.11n HT20 Channel 01

100kHz PSD reference Level

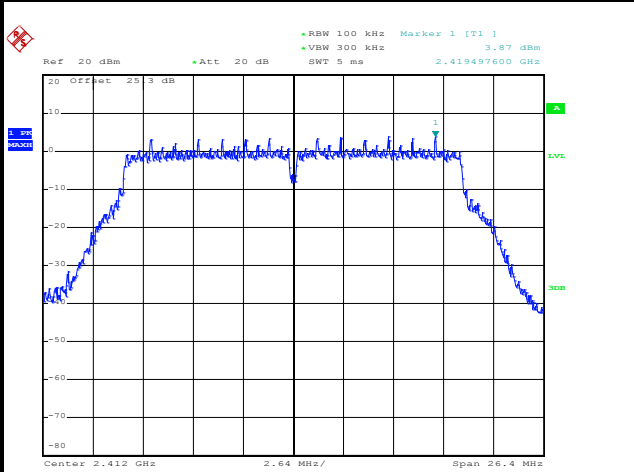

Date: 12.JUL.2017 18:48:45

Low Channel Plot

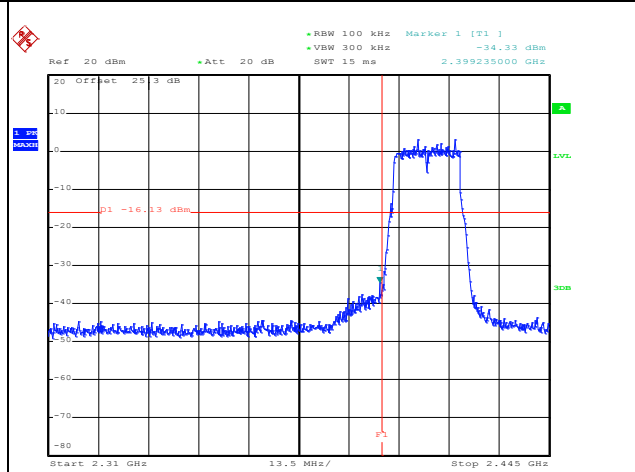

Date: 12.JUL.2017 18:48:58

Spurious Emission 30MHz~3GHz

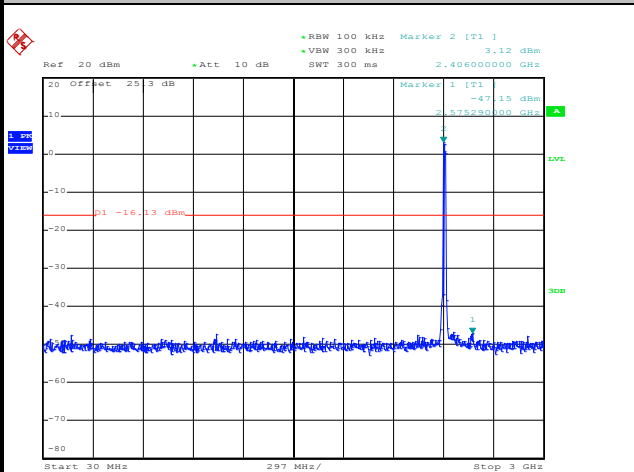

Date: 12.JUL.2017 18:49:09

Spurious Emission 2GHz~25GHz

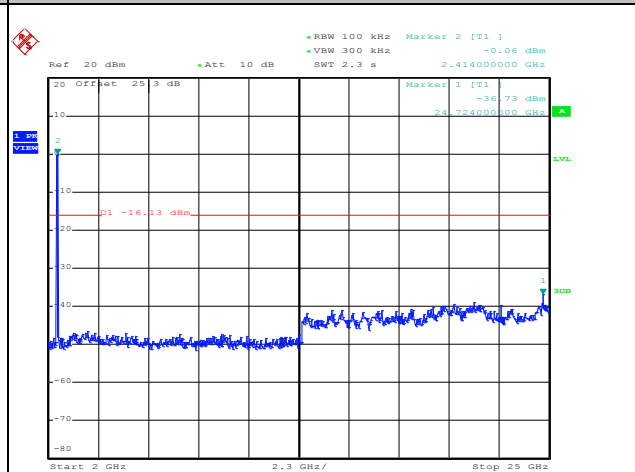

Date: 12.JUL.2017 18:49:18



Number of TX :	2	Ant. :	2
Test Mode :	802.11n HT20	Temperature :	21~25°C
Test Band :	2.4GHz Mid	Relative Humidity :	51~54%
Test Channel :	06	Test Engineer :	Aking Chang

WLAN 802.11n HT20 Channel 06

100kHz PSD reference Level

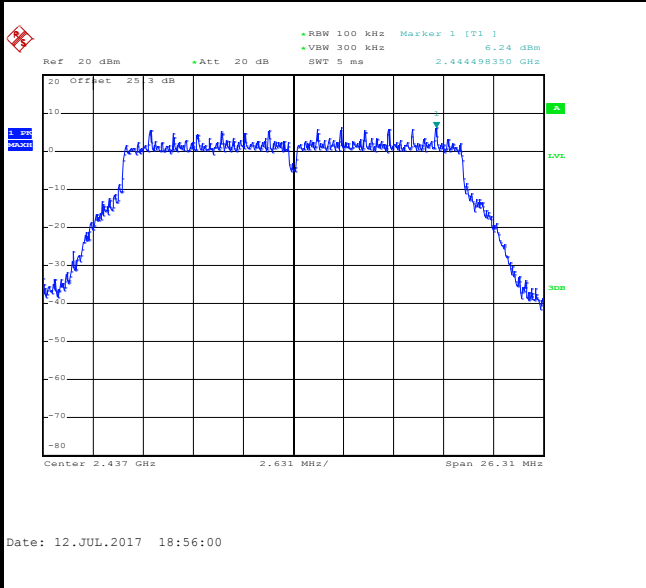

Spurious Emission 30MHz~3GHz

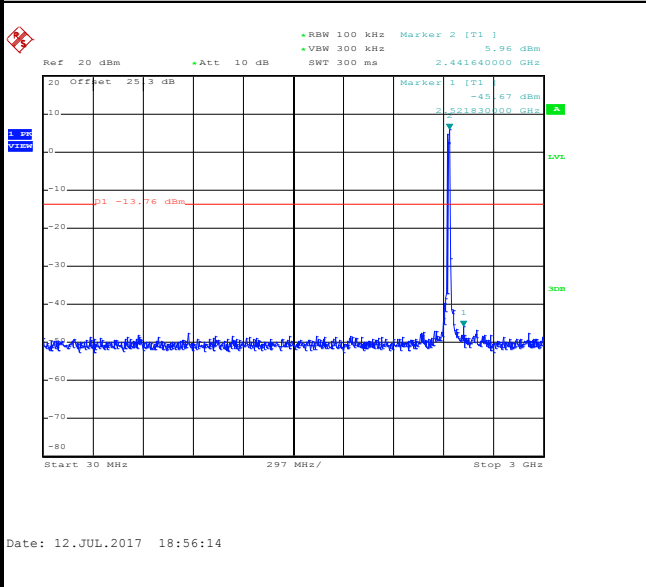

Spurious Emission 2GHz~25GHz

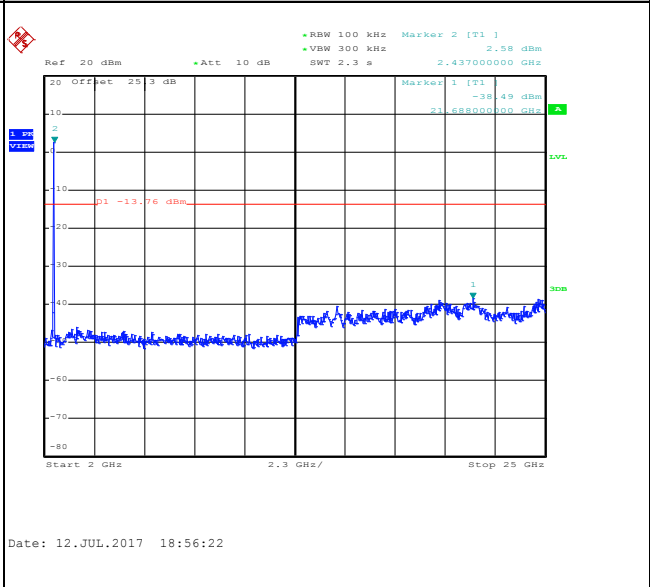



Number of TX :	2	Ant. :	2
Test Mode :	802.11n HT20	Temperature :	21~25°C
Test Band :	2.4GHz High	Relative Humidity :	51~54%
Test Channel :	11	Test Engineer :	Aking Chang

WLAN 802.11n HT20 Channel 11

100kHz PSD reference Level

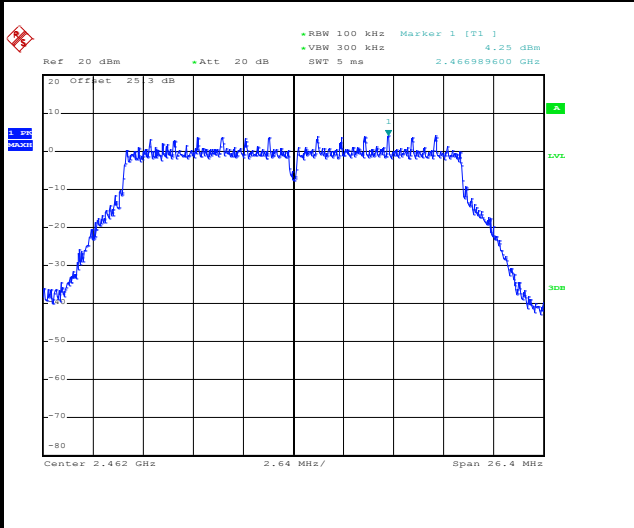

Date: 12.JUL.2017 19:04:08

High Channel Plot

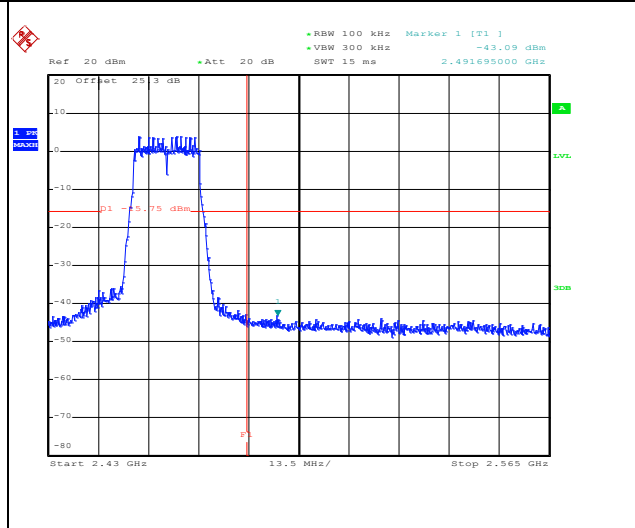

Date: 12.JUL.2017 19:04:26

Spurious Emission 30MHz~3GHz

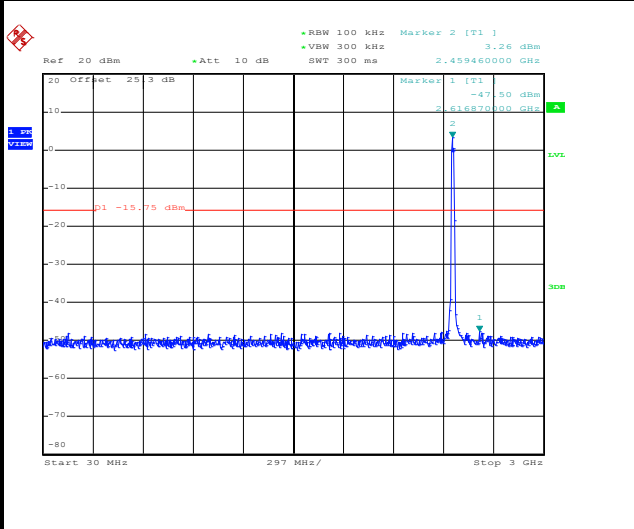

Date: 12.JUL.2017 19:04:43

Spurious Emission 2GHz~25GHz

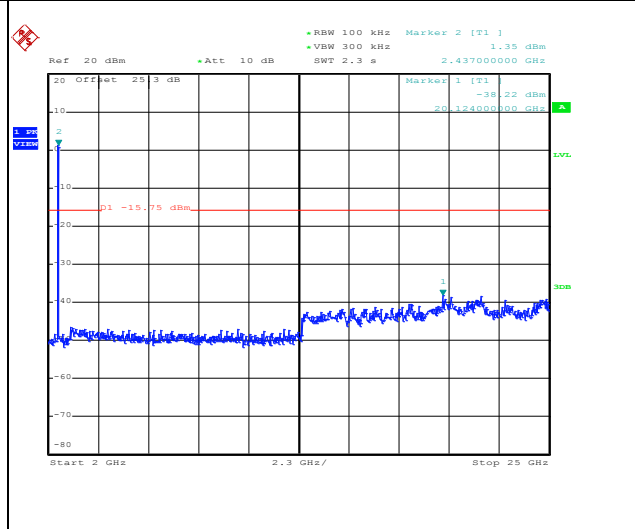

Date: 12.JUL.2017 19:04:52



Number of TX :	2	Ant. :	2
Test Mode :	802.11n HT20	Temperature :	21~25°C
Test Band :	2.4GHz High	Relative Humidity :	51~54%
Test Channel :	12	Test Engineer :	Aking Chang

WLAN 802.11n HT20 Channel 12

100kHz PSD reference Level

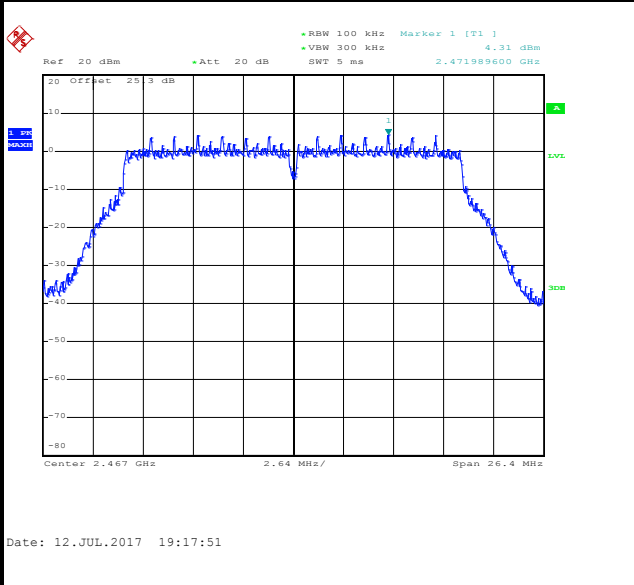

High Channel Plot

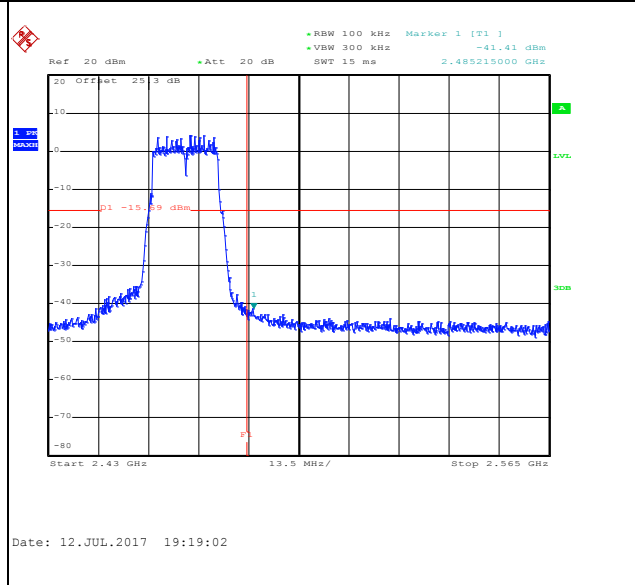

Spurious Emission 30MHz~3GHz

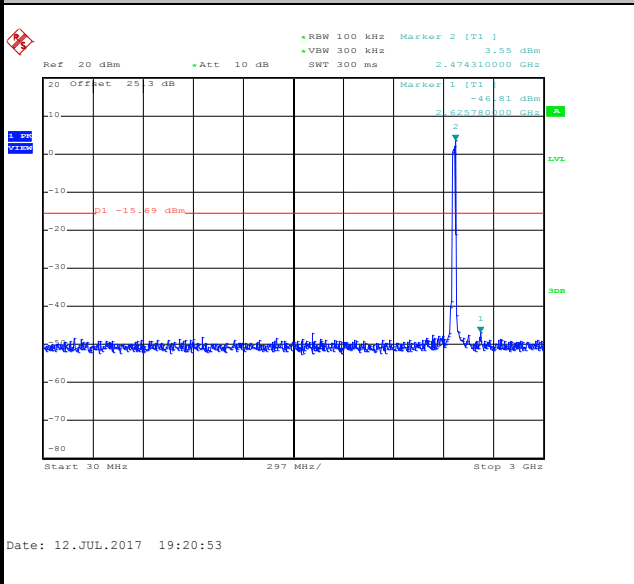

Spurious Emission 2GHz~25GHz

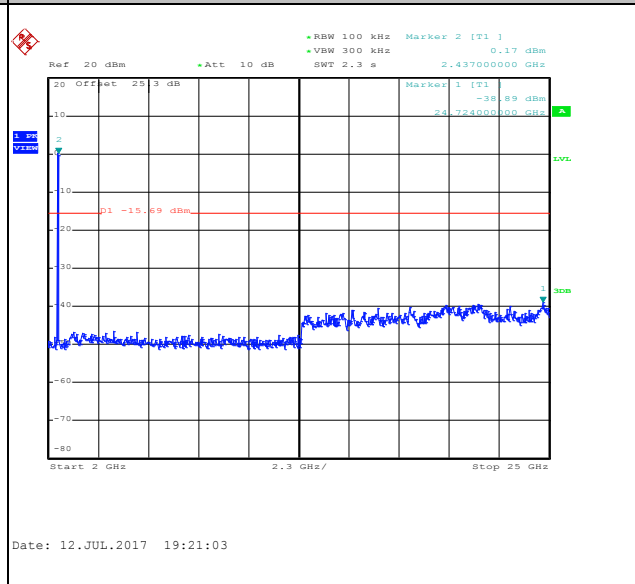



Number of TX :	2	Ant. :	2
Test Mode :	802.11n HT20	Temperature :	21~25°C
Test Band :	2.4GHz High	Relative Humidity :	51~54%
Test Channel :	13	Test Engineer :	Aking Chang

WLAN 802.11n HT20 Channel 13

100kHz PSD reference Level

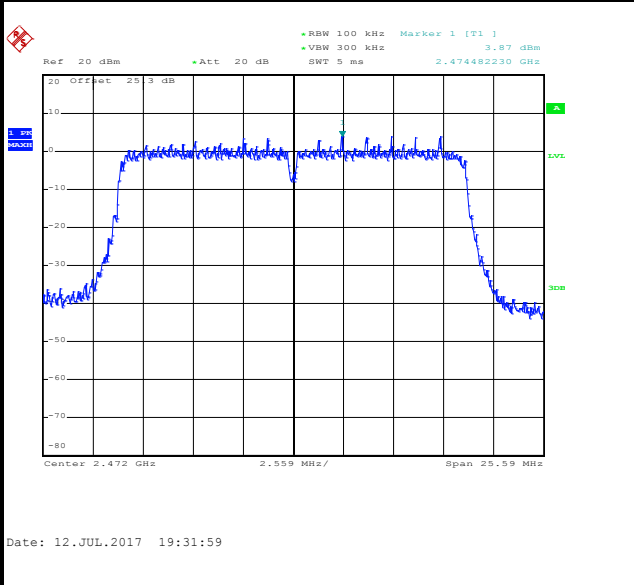

High Channel Plot

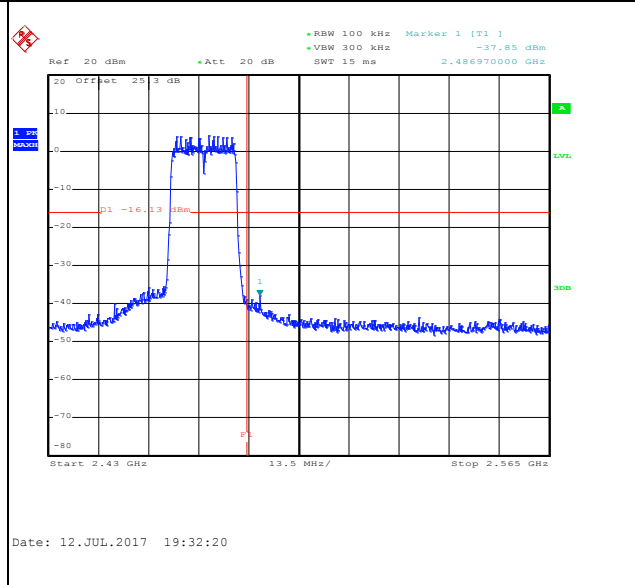

Spurious Emission 30MHz~3GHz

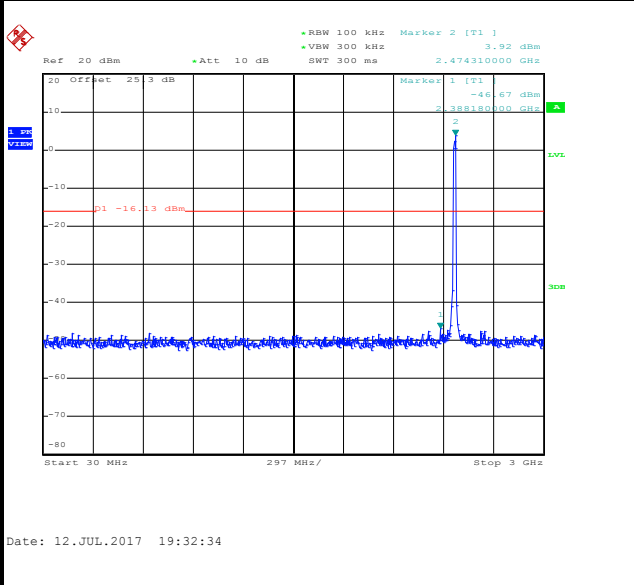

Spurious Emission 2GHz~25GHz

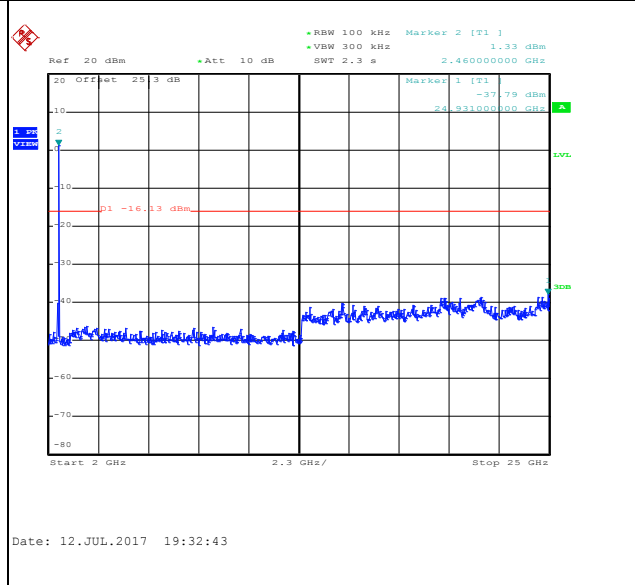



3.5 Radiated Band Edges and Spurious Emission Measurement

3.5.1 Limit of Radiated band edge and Spurious Emission Measurement

In any 100 kHz bandwidth outside the intentional radiator frequency band, all harmonics/spurious must be at least 20 dB below the highest emission level within the authorized band. If the output power of this device was measured by spectrum analyzer, the attenuation under this paragraph shall be 30 dB instead of 20 dB. In addition, radiated emissions which fall in the restricted bands must also comply with the limits as below.

Frequency (MHz)	Field Strength (microvolts/meter)	Measurement Distance (meters)
0.009 – 0.490	2400/F(kHz)	300
0.490 – 1.705	24000/F(kHz)	30
1.705 – 30.0	30	30
30 – 88	100	3
88 – 216	150	3
216 - 960	200	3
Above 960	500	3

3.5.2 Measuring Instruments

The measuring equipment is listed in the section 4 of this test report.



3.5.3 Test Procedures

1. The testing follows FCC KDB Publication No. 558074 D01 DTS Meas. Guidance v04.
2. The EUT was arranged to its worst case and then tune the antenna tower (from 1 m to 4 m) and turntable (from 0 degree to 360 degrees) to find the maximum reading. A pre-amp and a high pass filter are used for the test in order to get better signal level.
3. The EUT was placed on a turntable with 0.8 meter for frequency below 1GHz and 1.5 meter for frequency above 1GHz respectively above ground.
4. The EUT was set 3 meters from the interference receiving antenna, which was mounted on the top of a variable height antenna tower.
5. Corrected Reading: Antenna Factor + Cable Loss + Read Level - Preamp Factor = Level
6. For testing below 1GHz, if the emission level of the EUT in peak mode was 3 dB lower than the limit specified, then peak values of EUT will be reported, otherwise, the emissions will be repeated one by one using the CISPR quasi-peak method and reported.
7. For testing above 1GHz, the emission level of the EUT in peak mode was 20dB lower than average limit (that means the emission level in average mode also complies with the limit in average mode), then peak values of EUT will be reported, otherwise, the emissions will be measured in average mode again and reported.
8. Use the following spectrum analyzer settings:
 - (1) Span shall wide enough to fully capture the emission being measured;
 - (2) Set RBW=100 kHz for $f < 1$ GHz; VBW \geq RBW; Sweep = auto; Detector function = peak; Trace = max hold;
 - (3) Set RBW = 1 MHz, VBW= 3MHz for $f \geq 1$ GHz for peak measurement.
For average measurement:
 - VBW = 10 Hz, when duty cycle is no less than 98 percent.
 - VBW $\geq 1/T$, when duty cycle is less than 98 percent where T is the minimum transmission duration over which the transmitter is on and is transmitting at its maximum power control level for the tested mode of operation.

3.5.4 Test Setup

For radiated emissions below 30MHz

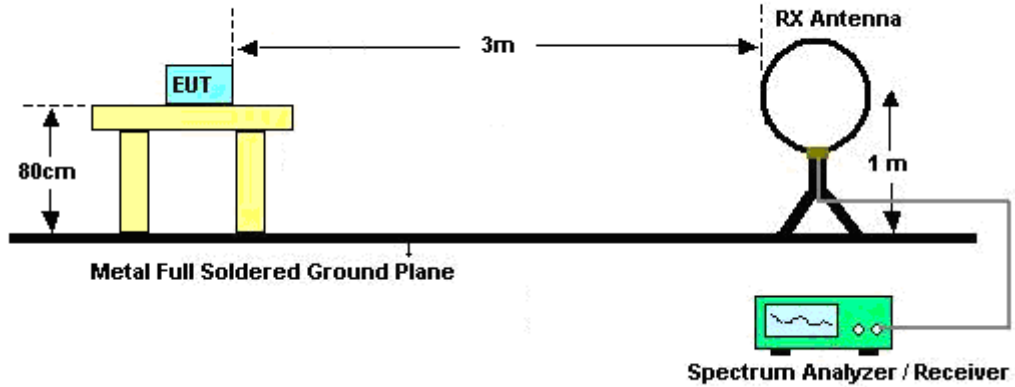

For radiated emissions from 30MHz to 1GHz

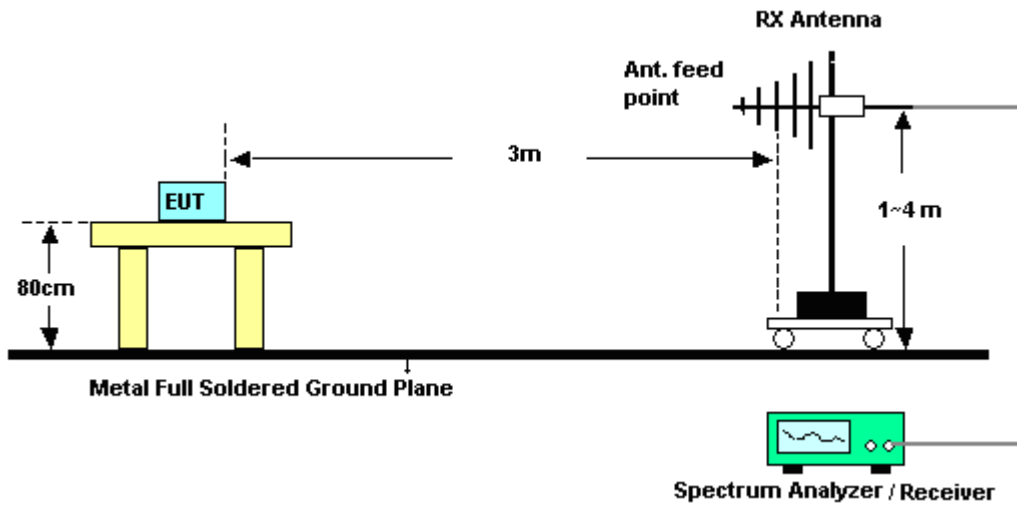

For radiated emissions above 1GHz

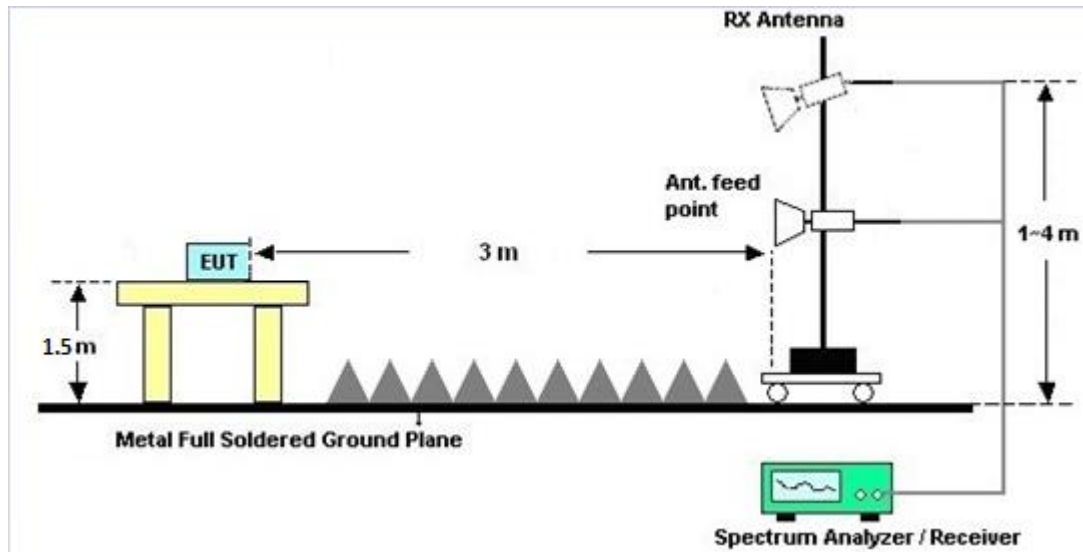

3.5.5 Test Results of Radiated Spurious Emissions (9kHz ~ 30MHz)

The low frequency, which started from 9 kHz to 30MHz, was pre-scanned and the result which was 20dB lower than the limit line was not reported.

There is a comparison data of both open-field test site and semi-Anechoic chamber, and the result came out very similar.

3.5.6 Test Result of Radiated Spurious at Band Edges

Please refer to Appendix C and D.

3.5.7 Duty Cycle

Please refer to Appendix E.

3.5.8 Test Result of Radiated Spurious Emission (30MHz ~ 10th Harmonic)

Please refer to Appendix C and D.



3.6 AC Conducted Emission Measurement

3.6.1 Limit of AC Conducted Emission

For equipment that is designed to be connected to the public utility (AC) power line, the radio frequency voltage that is conducted back onto the AC power line on any frequency or frequencies within the band 150 kHz to 30 MHz shall not exceed the limits in the following table.

Frequency of Emission (MHz)	Conducted Limit (dB μ V)	
	Quasi-Peak	Average
0.15-0.5	66 to 56*	56 to 46*
0.5-5	56	46
5-30	60	50

*Decreases with the logarithm of the frequency.

3.6.2 Measuring Instruments

The measuring equipment is listed in the section 4 of this test report.

3.6.3 Test Procedures

1. The EUT was placed 0.4 meter from the conducting wall of the shielding room, and it was kept at least 80 centimeters from any other grounded conducting surface.
2. Connect EUT to the power mains through a line impedance stabilization network (LISN).
3. All the support units are connecting to the other LISN.
4. The LISN provides 50 ohm coupling impedance for the measuring instrument.
5. The FCC states that a 50 ohm, 50 microhenry LISN should be used.
6. Both sides of AC line were checked for maximum conducted interference.
7. The frequency range from 150 kHz to 30 MHz was searched.
8. Set the test-receiver system to Peak Detect Function and specified bandwidth (IF Bandwidth = 9kHz) with Maximum Hold Mode. Then measurement is also conducted by Average Detector and Quasi-Peak Detector Function respectively.

3.6.4 Test Setup

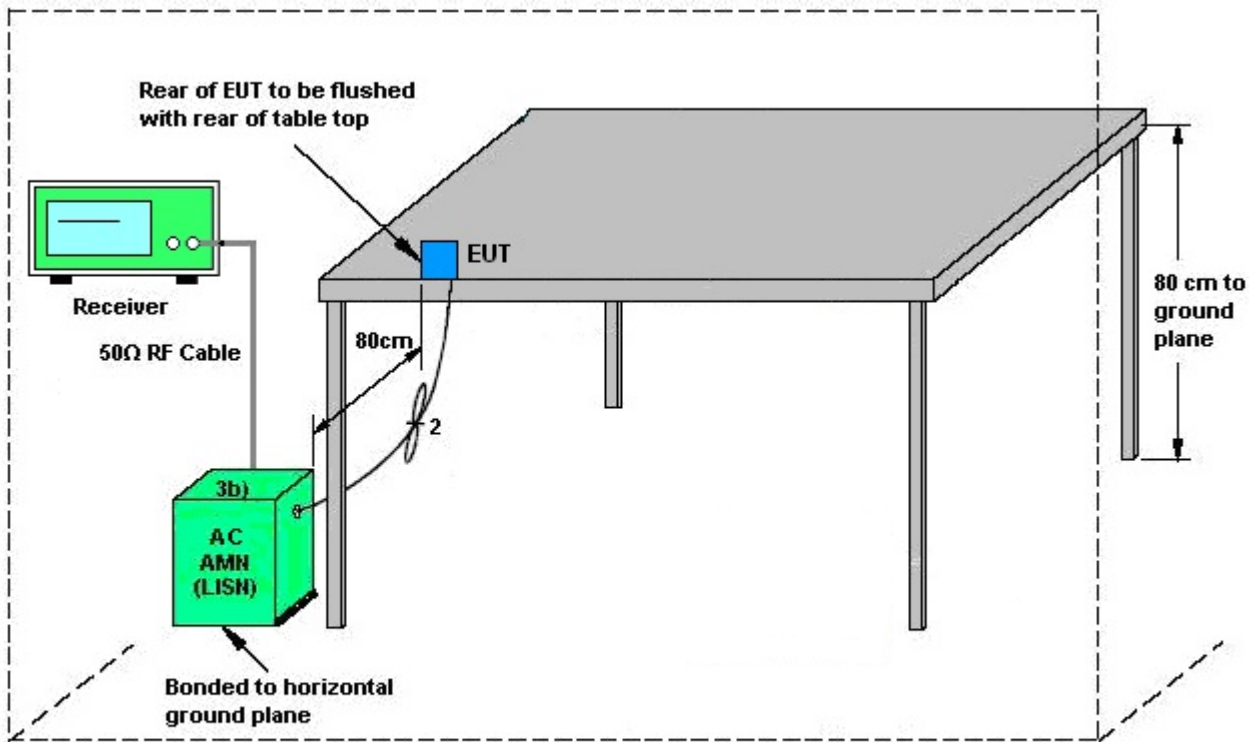

AMN = Artificial mains network (LISN)
 AE = Associated equipment
 EUT = Equipment under test
 ISN = Impedance stabilization network

3.6.5 Test Result of AC Conducted Emission

Please refer to Appendix B.



3.7 Antenna Requirements

3.7.1 Standard Applicable

If directional gain of transmitting Antennas is greater than 6dBi, the power shall be reduced by the same level in dB comparing to gain minus 6dBi. For the fixed point-to-point operation, the power shall be reduced by one dB for every 3 dB that the directional gain of the Antenna exceeds 6 dBi. The use of a permanently attached Antenna or of an Antenna that uses a unique coupling to the intentional radiator shall be considered sufficient to comply with the rule.

3.7.2 Antenna Anti-Replacement Construction

An embedded-in antenna design is used.

3.7.3 Antenna Gain

FCC KDB 662911 D01 Multiple Transmitter Output v02r01

For CDD transmissions, directional gain is calculated as

Directional gain = $G_{ANT} + \text{Array Gain}$, where Array Gain is as follows.

For power spectral density (PSD) measurements on all devices,

Array Gain = $10 \log(N_{ANT}/N_{SS}=1)$ dB.

For power measurements on IEEE 802.11 devices,

Array Gain = 0 dB (i.e., no array gain) for $N_{ANT} \leq 4$.

Directional gain may be calculated by using the formulas applicable to equal gain antennas with G_{ANT} set equal to the gain of the antenna having the highest gain;

The EUT supports CDD mode.

For power, the directional gain G_{ANT} is set equal to the antenna having the highest gain, i.e., F)2)f)i).

For PSD, the directional gain calculation is following F)2)f)ii) of KDB 662911 D01 v02r01.

The power and PSD limit should be modified if the directional gain of EUT is over 6 dBi,

The directional gain "DG" is calculated as following table.

	Ant. 1 (dBi)	Ant. 2 (dBi)	DG for Power (dBi)	DG for PSD (dBi)	Power Limit Reduction (dB)	PSD Limit Reduction (dB)
2.4 GHz	2.43	2.07	2.43	5.26	0.00	0.00

$Power\ Limit\ Reduction = DG(Power) - 6dBi, (min = 0)$

$PSD\ Limit\ Reduction = DG(PSD) - 6dBi, (min = 0)$



4 List of Measuring Equipment

Instrument	Manufacturer	Model No.	Serial No.	Characteristics	Calibration Date	Test Date	Due Date	Remark
Power Meter	Anritsu	ML2495A	0932001	N/A	Sep. 29, 2016	Jul. 05, 2017~ Jul. 12, 2017	Sep. 28, 2017	Conducted (TH05-HY)
Power Sensor	Anritsu	MA2411B	0846202	300MHz~40GHz	Sep. 29, 2016	Jul. 05, 2017~ Jul. 12, 2017	Sep. 28, 2017	Conducted (TH05-HY)
Spectrum Analyzer	Rohde & Schwarz	FSP40	100055	9kHz-40GHz	Jul. 17, 2016	Jul. 05, 2017~ Jul. 12, 2017	Jul. 16, 2017	Conducted (TH05-HY)
AC Power Source	ChainTek	APC-1000W	N/A	N/A	N/A	Jul. 07, 2017	N/A	Conduction (CO05-HY)
EMI Test Receiver	Rohde & Schwarz	ESCI 7	100724	9kHz~7GHz	Aug. 30, 2016	Jul. 07, 2017	Aug. 29, 2017	Conduction (CO05-HY)
LISN	Rohde & Schwarz	ENV216	100080	9kHz~30MHz	Nov. 29, 2016	Jul. 07, 2017	Nov. 28, 2017	Conduction (CO05-HY)
LISN	Rohde & Schwarz	ENV216	100081	9kHz~30MHz	Dec. 06, 2016	Jul. 07, 2017	Dec. 05, 2017	Conduction (CO05-HY)
Spectrum Analyzer	Keysight	N9010A	MY553705 26	N/A	Mar. 15, 2017	Jul. 07, 2017 ~ Jul. 30, 2017	Mar. 14, 2018	Radiation (03CH13-HY)
EMI Test Receiver	Agilent	N9038A(MXE)	MY532900 53	20Hz to 26.5GHz	Jan. 12, 2017	Jul. 07, 2017 ~ Jul. 30, 2017	Jan. 11, 2018	Radiation (03CH13-HY)
Loop Antenna	Rohde & Schwarz	HFH2-Z2	100315	9 kHz~30 MHz	May 15, 2017	Jul. 07, 2017 ~ Jul. 30, 2017	May 14, 2019	Radiation (03CH13-HY)
Bilog Antenna	TESEQ	CBL 6111D&00800 N1D01N-06	40103&04	30MHz to 1GHz	Jan. 07, 2017	Jul. 07, 2017 ~ Jul. 30, 2017	Jan. 06, 2018	Radiation (03CH13-HY)
Horn Antenna	SCHWARZBE CK	BBHA 9120 D	9120D-124 1	1GHz ~ 18GHz	May 02, 2017	Jul. 07, 2017 ~ Jul. 30, 2017	May 01, 2018	Radiation (03CH13-HY)
SHF-EHF Horn Antenna	SCHWARZBE CK	BBHA 9170	BBHA9170 584	18GHz- 40GHz	Nov. 08, 2016	Jul. 07, 2017 ~ Jul. 30, 2017	Nov. 07, 2017	Radiation (03CH13-HY)
Amplifier	Sonoma-Instru ment	310 N	187282	9KHz~1GHz	Dec. 21, 2016	Jul. 07, 2017 ~ Jul. 30, 2017	Dec. 20, 2017	Radiation (03CH13-HY)
Preamplifier	Keysight	83017A	MY532701 47	1GHz~26.5GHz	Jan. 09, 2017	Jul. 07, 2017 ~ Jul. 30, 2017	Jan. 08, 2018	Radiation (03CH13-HY)
Preamplifier	MITEQ	AMF-7D-0010 1800-30-10P	1590074	1GHz~18GHz	May 22, 2017	Jul. 07, 2017 ~ Jul. 30, 2017	May 21, 2018	Radiation (03CH13-HY)
Preamplifier	MITEQ	TTA 1840-35-HG	1887435	18GHz ~ 40GHz	Oct. 13, 2016	Jul. 07, 2017 ~ Jul. 30, 2017	Oct. 12, 2017	Radiation (03CH13-HY)
Antenna Mast	EMEC	AM-BS-4500- B	N/A	1m~4m	N/A	Jul. 07, 2017 ~ Jul. 30, 2017	N/A	Radiation (03CH13-HY)
Turn Table	EMEC	TT2000	N/A	0~360 Degree	N/A	Jul. 07, 2017 ~ Jul. 30, 2017	N/A	Radiation (03CH13-HY)



5 Uncertainty of Evaluation

Uncertainty of Conducted Emission Measurement (150kHz ~ 30MHz)

Measuring Uncertainty for a Level of Confidence of 95% ($U = 2Uc(y)$)	2.70
---	------

Uncertainty of Radiated Emission Measurement (30 MHz ~ 1000 MHz)

Measuring Uncertainty for a Level of Confidence of 95% ($U = 2Uc(y)$)	4.90
---	------

Uncertainty of Radiated Emission Measurement (1000 MHz ~ 18000 MHz)

Measuring Uncertainty for a Level of Confidence of 95% ($U = 2Uc(y)$)	5.40
---	------

Uncertainty of Radiated Emission Measurement (18000 MHz ~ 40000 MHz)

Measuring Uncertainty for a Level of Confidence of 95% ($U = 2Uc(y)$)	4.30
---	------

Appendix A. Test Result of Conducted Test Items

Test Engineer:	Aking chang	Temperature:	21~25	°C
Test Date:	2017/7/5~2017/7/12	Relative Humidity:	51~54	%

TEST RESULTS DATA
6dB and 99% Occupied Bandwidth

2.4GHz Band										
Mod.	Data Rate	NTX	CH.	Freq. (MHz)	99% Occupied BW (MHz)		6dB BW (MHz)		6dB BW Limit (MHz)	Pass/Fail
					Ant 1	Ant 2	Ant 1	Ant 2		
11b	1Mbps	1	1	2412	11.70	11.60	8.04	8.08	0.50	Pass
11b	1Mbps	1	6	2437	11.55	11.65	8.04	8.04	0.50	Pass
11b	1Mbps	1	11	2462	11.55	11.65	8.04	8.04	0.50	Pass
11b	1Mbps	1	12	2467	11.55	11.65	8.04	8.04	0.50	Pass
11b	1Mbps	1	13	2472	11.60	11.65	8.04	8.04	0.50	Pass
11g	6Mbps	2	1	2412	18.30	18.15	16.36	16.36	0.50	Pass
11g	6Mbps	2	6	2437	18.55	18.05	16.36	16.32	0.50	Pass
11g	6Mbps	2	11	2462	18.35	18.10	16.32	16.36	0.50	Pass
11g	6Mbps	2	12	2467	18.35	18.15	16.36	16.32	0.50	Pass
11g	6Mbps	2	13	2472	17.30	17.25	16.36	16.32	0.50	Pass
HT20	MCS0	2	1	2412	19.15	18.95	17.58	17.60	0.50	Pass
HT20	MCS0	2	6	2437	19.00	18.80	17.58	17.54	0.50	Pass
HT20	MCS0	2	11	2462	19.25	18.85	17.54	17.60	0.50	Pass
HT20	MCS0	2	12	2467	19.20	19.20	17.56	17.60	0.50	Pass
HT20	MCS0	2	13	2472	17.95	18.00	17.04	17.06	0.50	Pass

TEST RESULTS DATA
Peak Output Power

2.4GHz Band																
Mod.	Data Rate	N _{TX}	CH.	Freq. (MHz)	Peak Conducted Power (dBm)			Conducted Power Limit (dBm)		DG (dBi)		EIRP Power (dBm)		EIRP Power Limit (dBm)		Pass /Fail
					Ant 1	Ant 2	SUM	Ant 1	Ant 2	Ant 1	Ant 2	Ant 1	Ant 2	Ant 1	Ant 2	
11b	1Mbps	1	1	2412	22.62	21.40		30.00	30.00	2.43	2.07	25.05	23.47	36.00	36.00	Pass
11b	1Mbps	1	6	2437	18.35	22.31		30.00	30.00	2.43	2.07	20.78	24.38	36.00	36.00	Pass
11b	1Mbps	1	11	2462	19.66	21.48		30.00	30.00	2.43	2.07	22.09	23.55	36.00	36.00	Pass
11b	1Mbps	1	12	2467	19.50	20.49		30.00	30.00	2.43	2.07	21.93	22.56	36.00	36.00	Pass
11b	1Mbps	1	13	2472	18.30	17.56		30.00	30.00	2.43	2.07	20.73	19.63	36.00	36.00	Pass
11g	6Mbps	2	1	2412	24.30	24.56	27.44	30.00		2.43		29.87		36.00		Pass
11g	6Mbps	2	6	2437	23.30	23.73	26.53	30.00		2.43		28.96		36.00		Pass
11g	6Mbps	2	11	2462	24.59	24.90	27.76	30.00		2.43		30.19		36.00		Pass
11g	6Mbps	2	12	2467	22.60	23.11	25.87	30.00		2.43		28.30		36.00		Pass
11g	6Mbps	2	13	2472	23.30	23.53	26.43	30.00		2.43		28.86		36.00		Pass
HT20	MCS0	2	1	2412	23.05	23.35	26.21	30.00		2.43		28.64		36.00		Pass
HT20	MCS0	2	6	2437	23.63	24.25	26.96	30.00		2.43		29.39		36.00		Pass
HT20	MCS0	2	11	2462	23.94	24.15	27.06	30.00		2.43		29.49		36.00		Pass
HT20	MCS0	2	12	2467	22.51	22.60	25.57	30.00		2.43		28.00		36.00		Pass
HT20	MCS0	2	13	2472	23.20	23.45	26.34	30.00		2.43		28.77		36.00		Pass

Note: Measured power (dBm) has offset with cable loss.

TEST RESULTS DATA
Average Output Power

2.4GHz Band									
Mod.	Data Rate	N _{TX}	CH.	Freq. (MHz)	Duty Factor (dB)		Average Conducted Power (dBm)		
					Ant 1	Ant 2	Ant 1	Ant 2	SUM
11b	1Mbps	1	1	2412	0.06	0.06	19.41	18.21	
11b	1Mbps	1	6	2437	0.06	0.06	15.20	19.08	
11b	1Mbps	1	11	2462	0.06	0.06	16.46	18.27	
11b	1Mbps	1	12	2467	0.06	0.06	16.43	17.21	
11b	1Mbps	1	13	2472	0.06	0.06	15.11	14.27	
11g	6Mbps	2	1	2412	0.35	0.30	17.58	17.69	20.64
11g	6Mbps	2	6	2437	0.35	0.30	16.65	16.97	19.82
11g	6Mbps	2	11	2462	0.35	0.30	17.65	17.82	20.75
11g	6Mbps	2	12	2467	0.35	0.30	15.63	15.94	18.80
11g	6Mbps	2	13	2472	0.35	0.30	15.65	15.95	18.81
HT20	MCS0	2	1	2412	0.38	0.38	15.97	16.41	19.20
HT20	MCS0	2	6	2437	0.38	0.38	17.01	17.48	20.26
HT20	MCS0	2	11	2462	0.38	0.38	17.08	17.35	20.23
HT20	MCS0	2	12	2467	0.38	0.38	15.20	15.38	18.30
HT20	MCS0	2	13	2472	0.38	0.38	15.14	15.36	18.26

Note: Measured power (dBm) has offset with cable loss.

TEST RESULTS DATA
Peak Power Spectral Density

2.4GHz Band												
Mod.	Data Rate	NTX	CH.	Freq. (MHz)	Peak PSD (dBm/3kHz)			DG (dBi)		Peak PSD Limit (dBm/3kHz)		Pass/Fail
					Ant 1	Ant 2	Worse + 3.01	Ant 1	Ant 2	Ant 1	Ant 2	
11b	1Mbps	1	1	2412	-2.02	-4.87	-	2.43	2.07	8.00	8.00	Pass
11b	1Mbps	1	6	2437	-6.42	-3.00		2.43	2.07	8.00	8.00	Pass
11b	1Mbps	1	11	2462	-7.15	-4.86		2.43	2.07	8.00	8.00	Pass
11b	1Mbps	1	12	2467	-6.12	-4.14		2.43	2.07	8.00	8.00	Pass
11b	1Mbps	1	13	2472	-6.94	-8.20		2.43	2.07	8.00	8.00	Pass
11g	6Mbps	2	1	2412	-8.25	-8.47	-5.24	5.26		8.00		Pass
11g	6Mbps	2	6	2437	-7.39	-7.72	-4.38	5.26		8.00		Pass
11g	6Mbps	2	11	2462	-10.38	-8.62	-5.61	5.26		8.00		Pass
11g	6Mbps	2	12	2467	-10.31	-8.82	-5.81	5.26		8.00		Pass
11g	6Mbps	2	13	2472	-9.42	-9.17	-6.16	5.26		8.00		Pass
HT20	MCS0	2	1	2412	-10.10	-9.22	-6.21	5.26		8.00		Pass
HT20	MCS0	2	6	2437	-8.49	-8.70	-5.48	5.26		8.00		Pass
HT20	MCS0	2	11	2462	-10.42	-9.28	-6.27	5.26		8.00		Pass
HT20	MCS0	2	12	2467	-9.83	-10.56	-6.82	5.26		8.00		Pass
HT20	MCS0	2	13	2472	-10.24	-10.05	-7.04	5.26		8.00		Pass

Measured power density (dBm) has offset with cable loss.



Appendix B. Test Result of AC Conducted Emission

Test Engineer :	Eric Jeng	Temperature :	22~24°C
		Relative Humidity :	51~53%

EUT Information

Report NO : 742534-01
 Test Mode : Mode 1
 Test Voltage : 120Vac/60Hz
 Phase : Line

ENV216 Auto Test FCC Power Bar - L

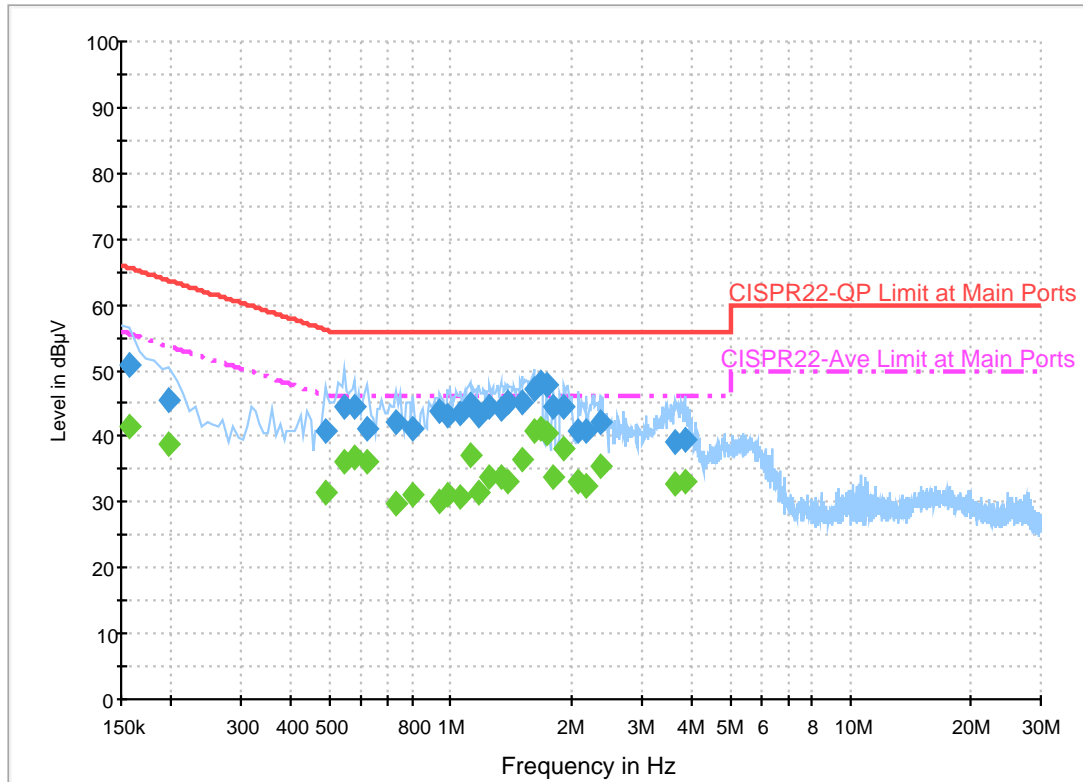

Final Result 1

Frequency (MHz)	QuasiPeak (dBµV)	Filter	Line	Corr. (dB)	Margin (dB)	Limit (dBµV)
0.158000	51.0	Off	L1	19.6	14.6	65.6
0.198000	45.5	Off	L1	19.6	18.2	63.7
0.486000	40.9	Off	L1	19.6	15.3	56.2
0.542000	44.4	Off	L1	19.6	11.6	56.0
0.574000	44.6	Off	L1	19.6	11.4	56.0
0.622000	41.2	Off	L1	19.6	14.8	56.0
0.734000	42.0	Off	L1	19.6	14.0	56.0
0.806000	41.2	Off	L1	19.6	14.8	56.0
0.942000	43.8	Off	L1	19.6	12.2	56.0
0.982000	43.3	Off	L1	19.6	12.7	56.0
1.062000	43.4	Off	L1	19.6	12.6	56.0
1.118000	45.0	Off	L1	19.6	11.0	56.0
1.174000	43.2	Off	L1	19.6	12.8	56.0
1.254000	44.6	Off	L1	19.6	11.4	56.0
1.334000	44.3	Off	L1	19.6	11.7	56.0
1.398000	45.1	Off	L1	19.6	10.9	56.0
1.510000	45.1	Off	L1	19.6	10.9	56.0
1.614000	47.1	Off	L1	19.6	8.9	56.0
1.686000	48.0	Off	L1	19.6	8.0	56.0
1.734000	47.7	Off	L1	19.6	8.3	56.0
1.814000	44.5	Off	L1	19.6	11.5	56.0
1.926000	44.3	Off	L1	19.6	11.7	56.0
2.094000	40.7	Off	L1	18.0	15.3	56.0

Frequency (MHz)	QuasiPeak (dBμV)	Filter	Line	Corr. (dB)	Margin (dB)	Limit (dBμV)
2.190000	40.8	Off	L1	18.5	15.2	56.0
2.366000	42.1	Off	L1	19.0	13.9	56.0
3.662000	39.2	Off	L1	19.7	16.8	56.0
3.854000	39.6	Off	L1	19.7	16.4	56.0

Final Result 2

Frequency (MHz)	Average (dBμV)	Filter	Line	Corr. (dB)	Margin (dB)	Limit (dBμV)
0.158000	41.4	Off	L1	19.6	14.2	55.6
0.198000	38.9	Off	L1	19.6	14.8	53.7
0.486000	31.5	Off	L1	19.6	14.7	46.2
0.542000	36.1	Off	L1	19.6	9.9	46.0
0.574000	37.0	Off	L1	19.6	9.0	46.0
0.622000	36.1	Off	L1	19.6	9.9	46.0
0.734000	29.9	Off	L1	19.6	16.1	46.0
0.806000	31.1	Off	L1	19.6	14.9	46.0
0.942000	30.2	Off	L1	19.6	15.8	46.0
0.982000	31.0	Off	L1	19.6	15.0	46.0
1.062000	30.9	Off	L1	19.6	15.1	46.0
1.118000	37.2	Off	L1	19.6	8.8	46.0
1.174000	31.6	Off	L1	19.6	14.4	46.0
1.254000	33.8	Off	L1	19.6	12.2	46.0
1.334000	33.8	Off	L1	19.6	12.2	46.0
1.398000	33.1	Off	L1	19.6	12.9	46.0
1.510000	36.6	Off	L1	19.6	9.4	46.0
1.614000	40.7	Off	L1	19.6	5.3	46.0
1.686000	41.2	Off	L1	19.6	4.8	46.0
1.734000	40.5	Off	L1	19.6	5.5	46.0
1.814000	33.9	Off	L1	19.6	12.1	46.0
1.926000	38.3	Off	L1	19.6	7.7	46.0
2.094000	33.2	Off	L1	18.0	12.8	46.0
2.190000	32.3	Off	L1	18.5	13.7	46.0
2.366000	35.5	Off	L1	19.0	10.5	46.0
3.662000	32.9	Off	L1	19.7	13.1	46.0
3.854000	33.0	Off	L1	19.7	13.0	46.0

EUT Information

Report NO : 742534-01
 Test Mode : Mode 1
 Test Voltage : 120Vac/60Hz
 Phase : Neutral

ENV216 Auto Test FCC Power Bar - N

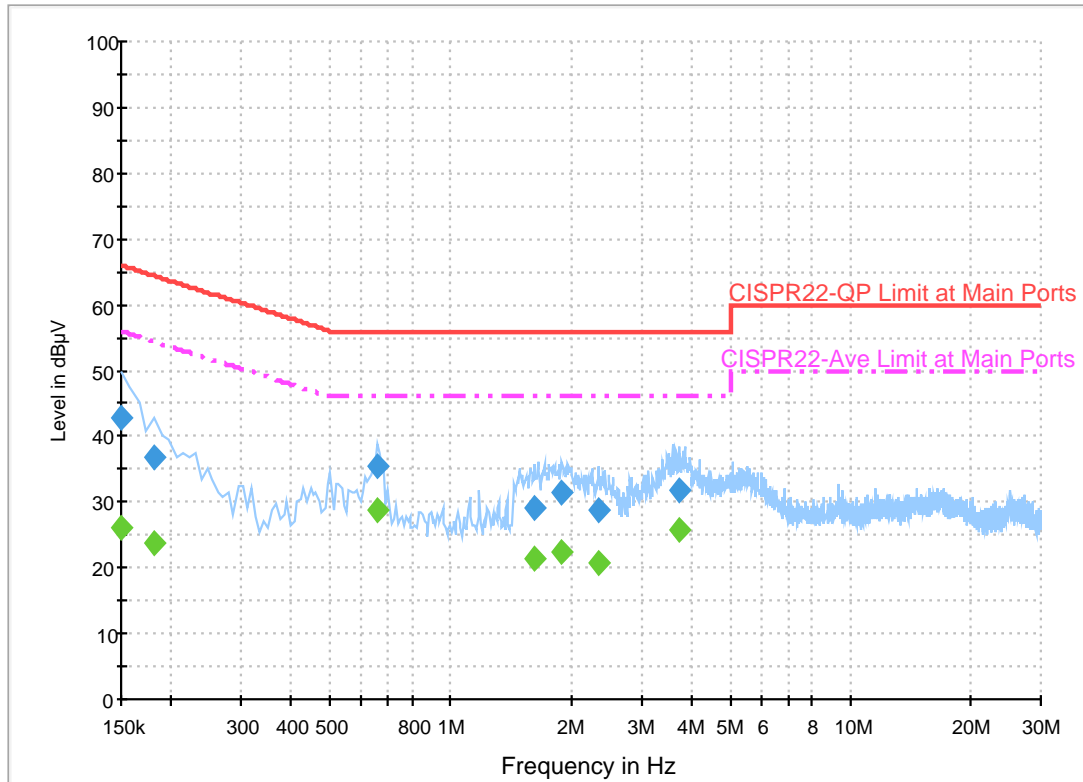

Final Result 1

Frequency (MHz)	QuasiPeak (dBµV)	Filter	Line	Corr. (dB)	Margin (dB)	Limit (dBµV)
0.150000	42.9	Off	N	19.5	23.1	66.0
0.182000	36.7	Off	N	19.5	27.7	64.4
0.654000	35.6	Off	N	19.6	20.4	56.0
1.622000	29.1	Off	N	19.6	26.9	56.0
1.902000	31.4	Off	N	19.6	24.6	56.0
2.350000	28.8	Off	N	19.0	27.2	56.0
3.742000	31.8	Off	N	19.7	24.2	56.0

Final Result 2

Frequency (MHz)	Average (dBµV)	Filter	Line	Corr. (dB)	Margin (dB)	Limit (dBµV)
0.150000	26.2	Off	N	19.5	29.8	56.0
0.182000	23.9	Off	N	19.5	30.5	54.4
0.654000	28.9	Off	N	19.6	17.1	46.0
1.622000	21.5	Off	N	19.6	24.5	46.0
1.902000	22.5	Off	N	19.6	23.5	46.0
2.350000	20.8	Off	N	19.0	25.2	46.0
3.742000	25.6	Off	N	19.7	20.4	46.0



Appendix C. Radiated Spurious Emission

Test Engineer :	Alex Jheng, Bill Chang and Wilson Wu	Temperature :	24.0~24.3°C
		Relative Humidity :	50~52%

2.4GHz 2400~2483.5MHz

WIFI 802.11b (Band Edge @ 3m)

WIFI Ant. 1	Note	Frequency (MHz)	Level (dBμV/m)	Over Limit (dB)	Limit Line (dBμV/m)	Read Level (dBμV)	Antenna Factor (dB/m)	Cable Loss (dB)	Preamp Factor (dB)	Ant Pos (cm)	Table Pos (deg)	Peak Avg. (P/A)	Pol. (H/V)
802.11b CH 01 2412MHz		2389.38	54.36	-19.64	74	43.22	27.37	4.83	30.99	395	59	P	H
		2387.28	46.13	-7.87	54	34.99	27.37	4.83	30.99	395	59	A	H
	*	2412	107.38	-	-	96.15	27.42	4.87	30.99	395	59	P	H
	*	2412	104.03	-	-	92.8	27.42	4.87	30.99	395	59	A	H
		2387.07	54.41	-19.59	74	43.27	27.37	4.83	30.99	336	288	P	V
		2387.28	46.32	-7.68	54	35.18	27.37	4.83	30.99	336	288	A	V
	*	2412	106.08	-	-	94.85	27.42	4.87	30.99	336	288	P	V
	*	2412	102.74	-	-	91.51	27.42	4.87	30.99	336	288	A	V
802.11b CH 06 2437MHz		2385.6	53.16	-20.84	74	42.02	27.37	4.83	30.99	385	68	P	H
		2389.38	41.51	-12.49	54	30.37	27.37	4.83	30.99	385	68	A	H
	*	2437	103.7	-	-	92.34	27.53	4.88	30.98	385	68	P	H
	*	2437	100.58	-	-	89.22	27.53	4.88	30.98	385	68	A	H
		2499.16	52.77	-21.23	74	41.17	27.7	4.93	30.96	385	68	P	H
		2491.25	41.14	-12.86	54	29.54	27.7	4.93	30.96	385	68	A	H
		2316.58	52.01	-21.99	74	41.26	27.09	4.74	31.01	338	311	P	V
		2389.24	41.23	-12.77	54	30.09	27.37	4.83	30.99	338	311	A	V
	*	2437	100.94	-	-	89.58	27.53	4.88	30.98	338	311	P	V
	*	2437	97.84	-	-	86.48	27.53	4.88	30.98	338	311	A	V
		2494.26	52.68	-21.32	74	41.08	27.7	4.93	30.96	338	311	P	V
	2491.88	40.84	-13.16	54	29.24	27.7	4.93	30.96	338	311	A	V	



802.11b CH 11 2462MHz	*	2462	106.33	-	-	94.88	27.59	4.9	30.97	376	65	P	H
	*	2462	103.18	-	-	91.73	27.59	4.9	30.97	376	65	A	H
		2483.64	53.78	-20.22	74	42.25	27.64	4.93	30.97	376	65	P	H
		2483.52	45.59	-8.41	54	34.06	27.64	4.93	30.97	376	65	A	H
	*	2462	104.21	-	-	92.76	27.59	4.9	30.97	110	314	P	V
	*	2462	101.34	-	-	89.89	27.59	4.9	30.97	110	314	A	V
		2483.6	53.08	-20.92	74	41.55	27.64	4.93	30.97	110	314	P	V
		2483.52	44.09	-9.91	54	32.56	27.64	4.93	30.97	110	314	A	V
802.11b CH 12 2467MHz	*	2467	106.2	-	-	94.73	27.59	4.92	30.97	376	63	P	H
	*	2467	103.08	-	-	91.61	27.59	4.92	30.97	376	63	A	H
		2483.56	57.67	-16.33	74	46.14	27.64	4.93	30.97	376	63	P	H
		2484.12	50.26	-3.74	54	38.73	27.64	4.93	30.97	376	63	A	H
	*	2467	103.33	-	-	91.86	27.59	4.92	30.97	108	316	P	V
	*	2467	100.13	-	-	88.66	27.59	4.92	30.97	108	316	A	V
		2483.56	55.64	-18.36	74	44.11	27.64	4.93	30.97	108	316	P	V
		2484.12	48.47	-5.53	54	36.94	27.64	4.93	30.97	108	316	A	V
802.11b CH 13 2472MHz	*	2472	104	30	-	-	27.64	4.92	30.97	374	61	P	H
	*	2472	100.88	46.88	-	-	27.64	4.92	30.97	374	61	A	H
		2487.48	58.62	-15.38	74	47.09	27.64	4.93	30.97	374	61	P	H
		2487.2	53.12	-0.88	54	41.59	27.64	4.93	30.97	374	61	A	H
	*	2472	104.11	30.11	-	-	27.64	4.92	30.97	379	317	P	V
	*	2472	100.93	46.93	-	-	27.64	4.92	30.97	379	317	A	V
		2484.48	61.32	-12.68	74	49.79	27.64	4.93	30.97	379	317	P	V
		2487.2	52.12	-1.88	54	40.59	27.64	4.93	30.97	379	317	A	V
Remark	<ol style="list-style-type: none"> No other spurious found. All results are PASS against Peak and Average limit line. 												



**2.4GHz 2400~2483.5MHz
WIFI 802.11b (Harmonic @ 3m)**

WIFI Ant. 1	Note	Frequency (MHz)	Level (dBμV/m)	Over Limit (dB)	Limit Line (dBμV/m)	Read Level (dBμV)	Antenna Factor (dB/m)	Cable Loss (dB)	Preamp Factor (dB)	Ant Pos (cm)	Table Pos (deg)	Peak Avg. (P/A)	Pol. (H/V)
802.11b CH 01 2412MHz		4824	41.15	-32.85	74	58.76	31.79	7.33	57.24	100	0	P	H
		4824	39.52	-34.48	74	57.13	31.79	7.33	57.24	100	0	P	V
802.11b CH 06 2437MHz		4874	39.35	-34.65	74	56.7	31.88	7.44	57.17	100	0	P	H
		7311	53.84	-20.16	74	64.35	37.17	9.13	57.27	197	162	P	H
		7311	47.7	-6.3	54	58.21	37.17	9.13	57.27	197	162	A	H
		4874	38.11	-35.89	74	55.46	31.88	7.44	57.17	100	0	P	V
802.11b CH 11 2462MHz		7311	49.24	-24.76	74	59.75	37.17	9.13	57.27	100	0	P	V
		4924	40.15	-33.85	74	57.25	31.98	7.52	57.1	100	0	P	H
		7386	55.26	-18.74	74	65.61	37.41	9.18	57.38	220	162	P	H
		7386	51.06	-2.94	54	61.41	37.41	9.18	57.38	220	162	A	H
802.11b CH 12 2467MHz		4924	39.1	-34.9	74	56.2	31.98	7.52	57.1	100	0	P	V
		7386	49.16	-24.84	74	59.51	37.41	9.18	57.38	100	0	P	V
		4934	41.13	-32.87	74	58.21	31.98	7.55	57.1	100	0	P	H
		7401	56.08	-17.92	74	66.39	37.46	9.19	57.4	196	180	P	H
		7401	52.09	-1.91	54	62.4	37.46	9.19	57.4	196	180	A	H
802.11b CH 13 2472MHz		3696	48.93	-25.07	74	70.26	29.32	6.39	57.87	100	0	P	V
		4934	38.56	-35.44	74	55.64	31.98	7.55	57.1	100	0	P	V
		7401	49.11	-24.89	74	59.42	37.46	9.19	57.4	100	0	P	V
		4944	40.87	-33.13	74	57.89	32.01	7.55	57.07	100	0	P	H
802.11b CH 13 2472MHz		7416	53.72	-20.28	74	64.01	37.46	9.2	57.4	212	188	P	H
		7416	48.99	-5.01	54	59.28	37.46	9.2	57.4	212	188	A	H
		4944	40.01	-33.99	74	57.03	32.01	7.55	57.07	100	0	P	V
		7416	47.71	-26.29	74	58	37.46	9.2	57.4	113	178	P	V
Remark	1. No other spurious found. 2. All results are PASS against Peak and Average limit line.												



Emission below 1GHz

2.4GHz WIFI 802.11b (LF)

WIFI	Note	Frequency	Level	Over	Limit	Read	Antenna	Cable	Preamp	Ant	Table	Peak	Pol.
Ant.				Limit	Line	Level	Factor	Loss	Factor	Pos	Pos	Avg.	
1		(MHz)	(dBμV/m)	(dB)	(dBμV/m)	(dBμV)	(dB/m)	(dB)	(dB)	(cm)	(deg)	(P/A)	(H/V)
2.4GHz 802.11b LF		77.25	21.51	-18.49	40	42.46	10.31	0.95	32.3			P	H
		92.1	34.63	-8.87	43.5	55.46	10.39	0.95	32.29			P	H
		283.26	29.67	-16.33	46	44.61	15.46	1.68	32.15			P	H
		661.2	39.8	-6.2	46	46.02	23.34	2.51	32.19	100	0	P	H
		707.4	38.72	-7.28	46	44.28	23.86	2.64	32.16			P	H
		755.7	36.56	-9.44	46	40.71	25.14	2.68	32.07			P	H
		77.25	30.27	-9.73	40	51.22	10.31	0.95	32.3			P	V
		108.03	31.84	-11.66	43.5	48.69	14.33	1	32.29			P	V
		282.99	26.48	-19.52	46	41.42	15.46	1.68	32.15			P	V
		500.2	34.18	-11.82	46	43.18	20.92	2.2	32.2			P	V
		673.1	34.24	-11.76	46	40.37	23.37	2.57	32.18			P	V
	706.7	37.97	-8.03	46	43.53	23.86	2.64	32.16	100	0	P	V	
Remark	1. No other spurious found. 2. All results are PASS against limit line.												



2.4GHz 2400~2483.5MHz
WIFI 802.11b (Band Edge @ 3m)

WIFI Ant.	Note	Frequency	Level	Over Limit	Limit Line	Read Level	Antenna Factor	Cable Loss	Preamp Factor	Ant Pos	Table Pos	Peak Avg.	Pol.
2		(MHz)	(dBμV/m)	(dB)	(dBμV/m)	(dBμV)	(dB/m)	(dB)	(dB)	(cm)	(deg)	(P/A)	(H/V)
802.11b CH 01 2412MHz		2386.86	56.44	-17.56	74	45.3	27.37	4.83	30.99	398	298	P	H
		2387.175	49.69	-4.31	54	38.55	27.37	4.83	30.99	398	298	A	H
	*	2412	107.93	-	-	96.7	27.42	4.87	30.99	398	298	P	H
	*	2412	104.8	-	-	93.57	27.42	4.87	30.99	398	298	A	
		2492	56.08	-17.92	74	44.48	27.7	4.93	30.96	398	298	P	H
		2492	48.5	-5.5	54	36.9	27.7	4.93	30.96	398	298	A	H
		2386.755	55.78	-18.22	74	44.64	27.37	4.83	30.99	101	225	P	V
		2387.175	48.37	-5.63	54	37.23	27.37	4.83	30.99	101	225	A	V
	*	2412	106.97	-	-	95.74	27.42	4.87	30.99	101	225	P	V
	*	2412	103.8	-	-	92.57	27.42	4.87	30.99	101	225	A	V
		2492	57.19	-16.81	74	45.59	27.7	4.93	30.96	101	225	P	V
		2492	49.75	-4.25	54	38.15	27.7	4.93	30.96	101	225	A	V
802.11b CH 06 2437MHz		2358.3	54.78	-19.22	74	43.79	27.26	4.8	31	336	301	P	H
		2357.88	45.41	-8.59	54	34.42	27.26	4.8	31	336	301	A	H
		2280	53.32	-20.68	74	42.74	26.98	4.69	31.02	336	301	P	H
		2280	44.59	-9.41	54	34.01	26.98	4.69	31.02	336	301	A	H
	*	2437	108.72	-	-	97.36	27.53	4.88	30.98	336	301	P	H
	*	2437	105.63	-	-	94.27	27.53	4.88	30.98	336	301	A	H
		2499.44	53.18	-20.82	74	41.58	27.7	4.93	30.96	336	301	P	H
		2489.15	42.73	-11.27	54	31.13	27.7	4.93	30.96	336	301	A	H
		2358.3	54.35	-19.65	74	43.36	27.26	4.8	31	117	243	P	V
		2358.02	46.36	-7.64	54	35.37	27.26	4.8	31	117	243	A	V
		2280	53.5	-20.5	74	42.92	26.98	4.69	31.02	117	243	P	V
		2280	44.46	-9.54	54	33.88	26.98	4.69	31.02	117	243	A	V
	*	2437	108.41	-	-	97.05	27.53	4.88	30.98	117	243	P	V
	*	2437	105.29	-	-	93.93	27.53	4.88	30.98	117	243	A	V
	2483.9	53.2	-20.8	74	41.67	27.64	4.93	30.97	117	243	P	V	
	2483.55	42.73	-11.27	54	31.2	27.64	4.93	30.97	117	243	A	V	



802.11b CH 11 2462MHz		2382	54.5	-19.5	74	43.42	27.31	4.83	30.99	387	317	P	H
		2382	46.11	-7.89	54	35.03	27.31	4.83	30.99	387	317	A	H
	*	2462	106.92	-	-	95.47	27.59	4.9	30.97	387	317	P	H
	*	2462	103.86	-	-	92.41	27.59	4.9	30.97	387	317	A	H
		2483.68	55.33	-18.67	74	43.8	27.64	4.93	30.97	387	317	P	H
		2483.52	47.97	-6.03	54	36.44	27.64	4.93	30.97	387	317	A	H
		2384	55.11	-18.89	74	44.03	27.31	4.83	30.99	111	244	P	V
		2384	47.75	-6.25	54	36.67	27.31	4.83	30.99	111	244	A	V
	*	2462	107.39	-	-	95.94	27.59	4.9	30.97	111	244	P	V
	*	2462	104.27	-	-	92.82	27.59	4.9	30.97	111	244	A	V
		2485.6	56.95	-17.05	74	45.42	27.64	4.93	30.97	111	244	P	V
		2483.52	49.89	-4.11	54	38.36	27.64	4.93	30.97	111	244	A	V
802.11b CH 12 2467MHz		2388	56.28	-17.72	74	45.14	27.37	4.83	30.99	340	308	P	H
		2388	48.86	-5.14	54	37.72	27.37	4.83	30.99	340	308	A	H
	*	2467	106.9	-	-	95.43	27.59	4.92	30.97	340	308	P	H
	*	2467	103.8	-	-	92.33	27.59	4.92	30.97	340	308	A	H
		2483.64	58.89	-15.11	74	47.36	27.64	4.93	30.97	340	308	P	H
		2484.12	52.33	-1.67	54	40.8	27.64	4.93	30.97	340	308	A	H
		2388	56.22	-17.78	74	45.08	27.37	4.83	30.99	110	242	A	V
		2386	48.02	-5.98	54	36.88	27.37	4.83	30.99	110	242	P	V
	*	2467	106.72	-	-	95.25	27.59	4.92	30.97	110	242	P	V
	*	2467	103.56	-	-	92.09	27.59	4.92	30.97	110	242	A	V
		2483.84	59.24	-14.76	74	47.71	27.64	4.93	30.97	110	242	P	V
		2484.12	53.38	-0.62	54	41.85	27.64	4.93	30.97	110	242	A	V



802.11b CH 13 2472MHz		2314	52.65	-21.35	74	41.9	27.09	4.74	31.01	333	307	P	H
		2314	44.7	-9.3	54	33.95	27.09	4.74	31.01	333	307	A	H
	*	2472	103.09	-	-	91.57	27.64	4.92	30.97	333	307	P	H
	*	2472	100	-	-	88.48	27.64	4.92	30.97	333	307	A	H
		2483.6	61.8	-12.2	74	50.27	27.64	4.93	30.97	333	307	P	H
		2487	53.32	-0.68	54	41.79	27.64	4.93	30.97	333	307	A	H
		2314	53.37	-20.63	74	42.62	27.09	4.74	31.01	107	244	P	V
		2314	45.23	-8.77	54	34.48	27.09	4.74	31.01	107	244	A	V
	*	2472	103.56	-	-	92.04	27.64	4.92	30.97	107	244	P	
	*	2472	100.39	-	-	88.87	27.64	4.92	30.97	107	244	A	
		2483.52	59.01	-14.99	74	47.48	27.64	4.93	30.97	107	244	P	V
		2485.84	53.34	-0.66	54	41.81	27.64	4.93	30.97	107	244	A	V
	Remark	1. No other spurious found. 2. All results are PASS against Peak and Average limit line.											



**2.4GHz 2400~2483.5MHz
WIFI 802.11b (Harmonic @ 3m)**

WIFI Ant. 2	Note	Frequency (MHz)	Level (dBμV/m)	Over Limit (dB)	Limit Line (dBμV/m)	Read Level (dBμV)	Antenna Factor (dB/m)	Cable Loss (dB)	Preamp Factor (dB)	Ant Pos (cm)	Table Pos (deg)	Peak Avg. (P/A)	Pol. (H/V)
802.11b CH 01 2412MHz		4824	41.58	-32.42	74	59.19	31.79	7.33	57.24	100	0	P	H
		4824	40.99	-33.01	74	58.6	31.79	7.33	57.24	100	0	P	V
802.11b CH 06 2437MHz		4874	40.76	-33.24	74	58.11	31.88	7.44	57.17	100	0	P	H
		7311	54.26	-19.74	74	64.77	37.17	9.13	57.27	219	197	P	H
		7311	47.94	-6.06	54	58.45	37.17	9.13	57.27	219	197	A	H
		3696	48.77	-25.23	74	70.1	29.32	6.39	57.87	100	0	P	V
		4874	40.74	-33.26	74	58.09	31.88	7.44	57.17	100	0	P	V
		7311	53.9	-20.1	74	64.41	37.17	9.13	57.27	106	208	P	V
		7311	46.93	-7.07	54	57.44	37.17	9.13	57.27	106	208	A	V
802.11b CH 11 2462MHz		4924	42.25	-31.75	74	59.35	31.98	7.52	57.1	100	0	P	H
		7386	52.77	-21.23	74	63.12	37.41	9.18	57.38	198	195	P	H
		7386	45.64	-8.36	54	55.99	37.41	9.18	57.38	198	195	A	H
		4924	41.98	-32.02	74	59.08	31.98	7.52	57.1	100	0	P	V
		7386	49.66	-24.34	74	60.01	37.41	9.18	57.38	100	0	P	V
802.11b CH 12 2467MHz		4934	40.26	-33.74	74	57.34	31.98	7.55	57.1	100	0	P	H
		7401	49.03	-24.97	74	59.34	37.46	9.19	57.4	100	0	P	H
		4934	40.15	-33.85	74	57.23	31.98	7.55	57.1	100	0	P	V
		7401	46.62	-27.38	74	56.93	37.46	9.19	57.4	100	0	P	V
802.11b CH 13 2472MHz		4944	39.82	-34.18	74	56.84	32.01	7.55	57.07	100	0	P	H
		7416	46.17	-27.83	74	56.46	37.46	9.2	57.4	100	0	P	H
		4944	38.55	-35.45	74	55.57	32.01	7.55	57.07	100	0	P	V
		7416	46.29	-27.71	74	56.58	37.46	9.2	57.4	100	0	P	V
Remark	1. No other spurious found. 2. All results are PASS against Peak and Average limit line.												



Emission below 1GHz

2.4GHz WIFI 802.11b (LF)

WIFI Ant. 2	Note	Frequency (MHz)	Level (dBμV/m)	Over Limit (dB)	Limit Line (dBμV/m)	Read Level (dBμV)	Antenna Factor (dB/m)	Cable Loss (dB)	Preamp Factor (dB)	Ant Pos (cm)	Table Pos (deg)	Peak Avg. (P/A)	Pol. (H/V)
2.4GHz 802.11b LF		93.72	33.88	-9.62	43.5	54.39	10.66	1	32.29			P	H
		134.22	30.89	-12.61	43.5	48.16	13.77	1.19	32.28			P	H
		281.91	29.6	-16.4	46	44.56	15.45	1.68	32.16			P	H
		675.2	38.46	-7.54	46	44.59	23.37	2.57	32.18			P	H
		709.5	39.14	-6.86	46	44.57	23.98	2.64	32.15	100	0	P	H
		755	36.38	-9.62	46	40.55	25.12	2.68	32.07			P	H
		78.06	30.86	-9.14	40	51.69	10.43	0.95	32.3	100	0	P	V
		108.03	30.29	-13.21	43.5	47.14	14.33	1	32.29			P	V
		282.99	28.46	-17.54	46	43.4	15.46	1.68	32.15			P	V
		497.4	34.45	-11.55	46	43.55	20.82	2.2	32.2			P	V
		647.9	34.85	-11.15	46	41	23.44	2.48	32.19			P	V
		704.6	36.71	-9.29	46	42.39	23.74	2.64	32.16			P	V
Remark	1. No other spurious found. 2. All results are PASS against limit line.												



2.4GHz 2400~2483.5MHz
WIFI 802.11g (Band Edge @ 3m)

WIFI Ant.	Note	Frequency	Level	Over Limit	Limit Line	Read Level	Antenna Factor	Cable Loss	Preamp Factor	Ant Pos	Table Pos	Peak Avg.	Pol.
1+2		(MHz)	(dBμV/m)	(dB)	(dBμV/m)	(dBμV)	(dB/m)	(dB)	(dB)	(cm)	(deg)	(P/A)	(H/V)
802.11g CH 01 2412MHz		2388.12	61.75	-12.25	74	50.61	27.37	4.83	30.99	400	300	P	H
		2390	50.78	-3.22	54	39.64	27.37	4.83	30.99	400	300	A	H
	*	2412	109.59	-	-	98.36	27.42	4.87	30.99	400	300	P	H
	*	2412	102.12	-	-	90.89	27.42	4.87	30.99	400	300	A	H
		2390	60.71	-13.29	74	49.57	27.37	4.83	30.99	100	225	P	V
		2387.7	50.28	-3.72	54	39.14	27.37	4.83	30.99	100	225	A	V
	*	2412	109.71	-	-	98.48	27.42	4.87	30.99	100	225	P	V
	*	2412	102.2	-	-	90.97	27.42	4.87	30.99	100	225	A	V
802.11g CH 06 2437MHz		2389.24	53.69	-20.31	74	42.55	27.37	4.83	30.99	385	306	P	H
		2389.8	43.94	-10.06	54	32.8	27.37	4.83	30.99	385	306	A	H
	*	2437	109.49	-	-	98.13	27.53	4.88	30.98	385	306	P	H
	*	2437	101.88	-	-	90.52	27.53	4.88	30.98	385	306	A	H
		2485.93	54.17	-19.83	74	42.64	27.64	4.93	30.97	385	306	P	H
		2489.36	45.03	-8.97	54	33.43	27.7	4.93	30.96	385	306	A	H
		2380.7	53.17	-20.83	74	42.09	27.31	4.83	30.99	114	247	P	V
		2389.94	44.64	-9.36	54	33.5	27.37	4.83	30.99	114	247	A	V
	*	2437	108.24	-	-	96.88	27.53	4.88	30.98	114	247	P	V
	*	2437	100.89	-	-	89.53	27.53	4.88	30.98	114	247	A	V
		2491.53	55.66	-18.34	74	44.06	27.7	4.93	30.96	114	247	P	V
		2484.81	45.38	-8.62	54	33.85	27.64	4.93	30.97	114	247	A	V



802.11g CH 11 2462MHz	*	2462	109.21	-	-	97.76	27.59	4.9	30.97	386	303	P	H
	*	2462	101.79	-	-	90.34	27.59	4.9	30.97	386	303	A	H
		2486.2	59.92	-14.08	74	48.39	27.64	4.93	30.97	386	303	P	H
		2485.48	49	-5	54	37.47	27.64	4.93	30.97	386	303	A	H
	*	2462	110	-	-	98.55	27.59	4.9	30.97	110	227	P	V
	*	2462	102.4	-	-	90.95	27.59	4.9	30.97	110	227	A	V
		2491	62.46	-11.54	74	50.86	27.7	4.93	30.96	110	227	P	V
		2485.52	50.35	-3.65	54	38.82	27.64	4.93	30.97	110	227	A	V
802.11g CH 12 2467MHz	*	2467	108.19	-	-	96.72	27.59	4.92	30.97	379	300	P	H
	*	2467	100.67	-	-	89.2	27.59	4.92	30.97	379	300	A	H
		2486.32	59.21	-14.79	74	47.68	27.64	4.93	30.97	379	300	P	H
		2485.4	48.31	-5.69	54	36.78	27.64	4.93	30.97	379	300	A	H
	*	2467	108.95	-	-	97.48	27.59	4.92	30.97	111	243	P	V
	*	2467	101.35	-	-	89.88	27.59	4.92	30.97	111	243	A	V
		2484.56	59.95	-14.05	74	48.42	27.64	4.93	30.97	111	243	P	V
		2483.6	48.91	-5.09	54	37.38	27.64	4.93	30.97	111	243	A	V
802.11g CH 13 2472MHz	*	2472	108.42	-	-	96.9	27.64	4.92	30.97	378	301	P	H
	*	2472	100.72	-	-	89.2	27.64	4.92	30.97	378	301	A	H
		2485.76	58.79	-15.21	74	47.26	27.64	4.93	30.97	378	301	P	H
		2483.52	49.25	-4.75	54	37.72	27.64	4.93	30.97	378	301	A	H
	*	2472	109.5	-	-	97.98	27.64	4.92	30.97	109	244	P	V
	*	2472	101.9	-	-	90.38	27.64	4.92	30.97	109	244	A	V
		2484.08	60.03	-13.97	74	48.5	27.64	4.93	30.97	109	244	P	V
		2483.52	49.97	-4.03	54	38.44	27.64	4.93	30.97	109	244	A	V
Remark	<ol style="list-style-type: none"> No other spurious found. All results are PASS against Peak and Average limit line. 												



**2.4GHz 2400~2483.5MHz
WIFI 802.11g (Harmonic @ 3m)**

WIFI Ant. 1+2	Note	Frequency (MHz)	Level (dBμV/m)	Over Limit (dB)	Limit Line (dBμV/m)	Read Level (dBμV)	Antenna Factor (dB/m)	Cable Loss (dB)	Preamp Factor (dB)	Ant Pos (cm)	Table Pos (deg)	Peak Avg. (P/A)	Pol. (H/V)
802.11g CH 01 2412MHz		4824	40.52	-33.48	74	58.13	31.79	7.33	57.24	100	0	P	H
		4824	39.68	-34.32	74	57.29	31.79	7.33	57.24	100	0	P	V
802.11g CH 06 2437MHz		4874	40.4	-33.6	74	57.75	31.88	7.44	57.17	100	0	P	H
		7311	58.84	-15.16	74	69.35	37.17	9.13	57.27	229	183	P	H
		7311	50.67	-3.33	54	61.18	37.17	9.13	57.27	229	183	A	H
		4874	38.4	-35.6	74	55.75	31.88	7.44	57.17	100	0	P	V
		7311	53.63	-20.37	74	64.14	37.17	9.13	57.27	231	159	P	V
		7311	44.49	-9.51	54	55	37.17	9.13	57.27	231	159	A	V
802.11g CH 11 2462MHz		4924	39.35	-34.65	74	56.45	31.98	7.52	57.1	100	0	P	H
		7386	61.08	-12.92	74	71.43	37.41	9.18	57.38	212	189	P	H
		7386	52.12	-1.88	54	62.47	37.41	9.18	57.38	212	189	A	H
		4924	39.24	-34.76	74	56.34	31.98	7.52	57.1	100	0	P	V
		7386	52.81	-21.19	74	63.16	37.41	9.18	57.38	200	208	P	V
		7386	44.67	-9.33	54	55.02	37.41	9.18	57.38	200	208	A	V



802.11g CH 12 2467MHz		4934	38.76	-35.24	74	55.84	31.98	7.55	57.1	100	0	P	H
		7401	56.54	-17.46	74	66.85	37.46	9.19	57.4	228	192	P	H
		7401	48.23	-5.77	54	58.54	37.46	9.19	57.4	228	192	A	H
		4704	42.3	-31.7	74	60.26	31.57	7.36	57.41	100	0	P	V
		4934	39.17	-34.83	74	56.25	31.98	7.55	57.1	100	0	P	V
		7401	49.73	-24.27	74	60.04	37.46	9.19	57.4	100	0	P	V
802.11g CH 13 2472MHz		3708	39.73	-34.27	74	61.06	29.32	6.4	57.87	100	0	P	H
		4944	38.82	-35.18	74	55.84	32.01	7.55	57.07	100	0	P	H
		7416	56.63	-17.37	74	66.92	37.46	9.2	57.4	207	188	P	H
		7416	48.19	-5.81	54	58.48	37.46	9.2	57.4	207	188	A	H
		4704	45.11	-28.89	74	63.07	31.57	7.36	57.41	100	0	P	V
		4944	37.8	-36.2	74	54.82	32.01	7.55	57.07	100	0	P	V
	7416	47.32	-26.68	74	57.61	37.46	9.2	57.4	100	0	P	V	
Remark	1. No other spurious found. 2. All results are PASS against Peak and Average limit line.												



**2.4GHz 2400~2483.5MHz
WIFI 802.11n HT20 (Band Edge @ 3m)**

WIFI Ant. 1+2	Note	Frequency (MHz)	Level (dBμV/m)	Over Limit (dB)	Limit Line (dBμV/m)	Read Level (dBμV)	Antenna Factor (dB/m)	Cable Loss (dB)	Preamp Factor (dB)	Ant Pos (cm)	Table Pos (deg)	Peak Avg. (P/A)	Pol. (H/V)
802.11n HT20 CH 01 2412MHz		2389.485	59.86	-14.14	74	48.72	27.37	4.83	30.99	397	301	P	H
		2389.905	49.31	-4.69	54	38.17	27.37	4.83	30.99	397	301	A	H
	*	2414	107.68	-	-	96.44	27.42	4.87	30.98	397	301	P	H
	*	2412	100.14	-	-	88.91	27.42	4.87	30.99	397	301	A	H
		2389.17	58.34	-15.66	74	47.2	27.37	4.83	30.99	100	221	P	V
		2389.485	49.94	-4.06	54	38.8	27.37	4.83	30.99	100	221	A	V
	*	2412	108.11	-	-	96.88	27.42	4.87	30.99	100	221	P	V
	*	2412	100.35	-	-	89.12	27.42	4.87	30.99	100	221	A	V
802.11n HT20 CH 06 2437MHz		2389.66	54.87	-19.13	74	43.73	27.37	4.83	30.99	393	299	P	H
		2389.38	44.59	-9.41	54	33.45	27.37	4.83	30.99	393	299	A	H
	*	2437	110.15	-	-	98.79	27.53	4.88	30.98	393	299	P	H
	*	2437	101.73	-	-	90.37	27.53	4.88	30.98	393	299	A	H
		2490.83	53.62	-20.38	74	42.02	27.7	4.93	30.96	393	299	P	H
		2487.26	43.95	-10.05	54	32.42	27.64	4.93	30.97	393	299	A	H
		2381.54	55.63	-18.37	74	44.55	27.31	4.83	30.99	118	243	P	V
		2389.38	46.32	-7.68	54	35.18	27.37	4.83	30.99	118	243	A	V
	*	2437	110.61	-	-	99.25	27.53	4.88	30.98	118	243	P	V
	*	2437	102.77	-	-	91.41	27.53	4.88	30.98	118	243	A	V
		2486.14	56.01	-17.99	74	44.48	27.64	4.93	30.97	118	243	P	V
		2484.11	46.07	-7.93	54	34.54	27.64	4.93	30.97	118	243	A	V



802.11n HT20 CH 11 2462MHz	*	2462	108.27	-	-	96.82	27.59	4.9	30.97	379	286	P	H
	*	2462	101.38	-	-	89.93	27.59	4.9	30.97	379	286	A	H
		2484	61.82	-12.18	74	50.29	27.64	4.93	30.97	379	286	P	H
		2483.64	50.61	-3.39	54	39.08	27.64	4.93	30.97	379	286	A	H
	*	2462	108.55	-	-	97.1	27.59	4.9	30.97	111	230	P	V
	*	2462	101.39	-	-	89.94	27.59	4.9	30.97	111	230	A	V
		2484.52	61.77	-12.23	74	50.24	27.64	4.93	30.97	111	230	P	V
		2483.88	50.59	-3.41	54	39.06	27.64	4.93	30.97	111	230	A	V
802.11n HT20 CH 12 2467MHz	*	2467	106.6	-	-	95.13	27.59	4.92	30.97	379	301	P	H
	*	2467	99.4	-	-	87.93	27.59	4.92	30.97	379	301	A	H
		2484.6	57.69	-16.31	74	46.16	27.64	4.93	30.97	379	301	P	H
		2484.12	47.62	-6.38	54	36.09	27.64	4.93	30.97	379	301	A	H
	*	2467	108.38	-	-	96.91	27.59	4.92	30.97	110	244	P	V
	*	2467	100.81	-	-	89.34	27.59	4.92	30.97	110	244	A	V
		2483.96	58.49	-15.51	74	46.96	27.64	4.93	30.97	110	244	P	V
		2483.52	48.79	-5.21	54	37.26	27.64	4.93	30.97	110	244	A	V
802.11n HT20 CH 13 2472MHz	*	2472	106.5	-	-	94.98	27.64	4.92	30.97	371	299	P	H
	*	2472	99.35	-	-	87.83	27.64	4.92	30.97	371	299	A	H
		2484.6	61.07	-12.93	74	49.54	27.64	4.93	30.97	371	299	P	H
		2483.92	51.08	-2.92	54	39.55	27.64	4.93	30.97	371	299	A	H
	*	2472	107.76	-	-	96.24	27.64	4.92	30.97	112	244	P	V
	*	2472	100.52	-	-	89	27.64	4.92	30.97	112	244	A	V
		2484.2	62.92	-11.08	74	51.39	27.64	4.93	30.97	112	244	P	V
		2484.24	50.95	-3.05	54	39.42	27.64	4.93	30.97	112	244	A	V
Remark	1. No other spurious found. 2. All results are PASS against Peak and Average limit line.												



**2.4GHz 2400~2483.5MHz
WIFI 802.11n HT20 (Harmonic @ 3m)**

WIFI Ant. 1+2	Note	Frequency (MHz)	Level (dBμV/m)	Over Limit (dB)	Limit Line (dBμV/m)	Read Level (dBμV)	Antenna Factor (dB/m)	Cable Loss (dB)	Preamp Factor (dB)	Ant Pos (cm)	Table Pos (deg)	Peak Avg. (P/A)	Pol. (H/V)
802.11n HT20 CH 01 2412MHz		4824	39.52	-34.48	74	57.13	31.79	7.33	57.24	100	0	P	H
		4824	38.99	-35.01	74	56.6	31.79	7.33	57.24	100	0	P	V
802.11n HT20 CH 06 2437MHz		4874	40.33	-33.67	74	57.68	31.88	7.44	57.17	100	0	P	H
		7311	60.16	-13.84	74	70.67	37.17	9.13	57.27	195	195	P	H
		7311	51.54	-2.46	54	62.05	37.17	9.13	57.27	195	195	A	H
		3696	42.27	-31.73	74	63.6	29.32	6.39	57.87	100	0	P	V
		4874	39.43	-34.57	74	56.78	31.88	7.44	57.17	100	0	P	V
		7311	52.62	-21.38	74	63.13	37.17	9.13	57.27	400	176	P	V
802.11n HT20 CH 11 2462MHz		7311	44.18	-9.82	54	54.69	37.17	9.13	57.27	400	176	A	V
		4924	40.59	-33.41	74	57.69	31.98	7.52	57.1	100	0	P	H
		7386	58.76	-15.24	74	69.11	37.41	9.18	57.38	237	191	P	H
		7386	49.91	-4.09	54	60.26	37.41	9.18	57.38	237	191	A	H
		4924	40.3	-33.7	74	57.4	31.98	7.52	57.1	100	0	P	V
		7386	52.57	-21.43	74	62.92	37.41	9.18	57.38	101	207	P	V
		7386	44.84	-9.16	54	55.19	37.41	9.18	57.38	101	207	P	V



802.11n HT20 CH 12 2467MHz		4934	41.44	-32.56	74	58.52	31.98	7.55	57.1	100	0	P	H
		7401	58.62	-15.38	74	68.93	37.46	9.19	57.4	212	187	P	H
		7401	46.45	-7.55	54	56.76	37.46	9.19	57.4	212	187	A	H
		3696	40.12	-33.88	74	61.45	29.32	6.39	57.87	100	0	P	V
		4934	39.71	-34.29	74	56.79	31.98	7.55	57.1	100	0	P	V
		7401	47.38	-26.62	74	57.69	37.46	9.19	57.4	100	0	P	V
802.11n HT20 CH 13 2472MHz		4944	39.89	-34.11	74	56.91	32.01	7.55	57.07	100	0	P	H
		7416	57.66	-16.34	74	67.95	37.46	9.2	57.4	213	188	P	H
		7416	45.85	-8.15	54	56.14	37.46	9.2	57.4	213	188	A	H
		4944	38.65	-35.35	74	55.67	32.01	7.55	57.07	100	0	P	V
		7416	47.7	-26.3	74	57.99	37.46	9.2	57.4	100	0	P	V
Remark	1. No other spurious found. 2. All results are PASS against Peak and Average limit line.												



Emission below 1GHz
2.4GHz WIFI 802.11g (LF)

Table with 14 columns: WIFI, Note, Frequency, Level, Over, Limit, Read, Antenna, Cable, Preamp, Ant, Table, Peak, Pol. It contains 12 rows of test data for 2.4GHz WIFI 802.11g LF and a Remark section at the bottom.



Note symbol

*	Fundamental Frequency which can be ignored. However, the level of any unwanted emissions shall not exceed the level of the fundamental frequency.
!	Test result is over limit line.
P/A	Peak or Average
H/V	Horizontal or Vertical



A calculation example for radiated spurious emission is shown as below:

WIFI	Note	Frequency	Level	Over	Limit	Read	Antenna	Cable	Preamp	Ant	Table	Peak	Pol.
Ant.				Limit	Line	Level	Factor	Loss	Factor	Pos	Pos	Avg.	
1+2		(MHz)	(dBμV/m)	(dB)	(dBμV/m)	(dBμV)	(dB/m)	(dB)	(dB)	(cm)	(deg)	(P/A)	(H/V)
802.11b		2390	55.45	-18.55	74	54.51	32.22	4.58	35.86	103	308	P	H
CH 01													
2412MHz		2390	43.54	-10.46	54	42.6	32.22	4.58	35.86	103	308	A	H

- Level(dBμV/m) =
Antenna Factor(dB/m) + Cable Loss(dB) + Read Level(dBμV) - Preamp Factor(dB)
- Over Limit(dB) = Level(dBμV/m) – Limit Line(dBμV/m)

For Peak Limit @ 2390MHz:

- Level(dBμV/m)
= Antenna Factor(dB/m) + Cable Loss(dB) + Read Level(dBμV) - Preamp Factor(dB)
= 32.22(dB/m) + 4.58(dB) + 54.51(dBμV) – 35.86 (dB)
= 55.45 (dBμV/m)
- Over Limit(dB)
= Level(dBμV/m) – Limit Line(dBμV/m)
= 55.45(dBμV/m) – 74(dBμV/m)
= -18.55(dB)

For Average Limit @ 2390MHz:

- Level(dBμV/m)
= Antenna Factor(dB/m) + Cable Loss(dB) + Read Level(dBμV) - Preamp Factor(dB)
= 32.22(dB/m) + 4.58(dB) + 42.6(dBμV) – 35.86 (dB)
= 43.54 (dBμV/m)
- Over Limit(dB)
= Level(dBμV/m) – Limit Line(dBμV/m)
= 43.54(dBμV/m) – 54(dBμV/m)
= -10.46(dB)

Both peak and average measured complies with the limit line, so test result is “PASS”.



Appendix D. Radiated Spurious Emission Plots

Test Engineer :	Alex Jheng, Bill Chang and Wilson Wu	Temperature :	24.0~24.3°C
		Relative Humidity :	50~52%

Note symbol

-L	Low channel location
-R	High channel location



2.4GHz 2400~2483.5MHz

WIFI 802.11b (Band Edge @ 3m)

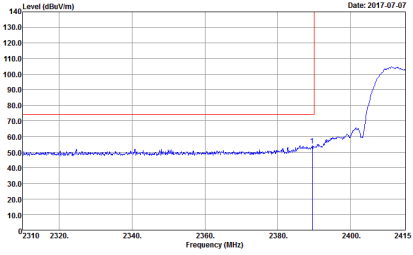
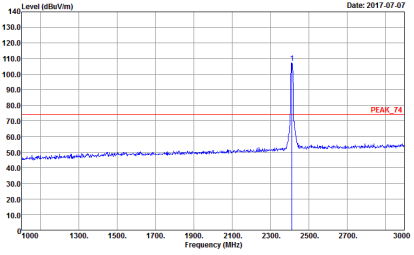
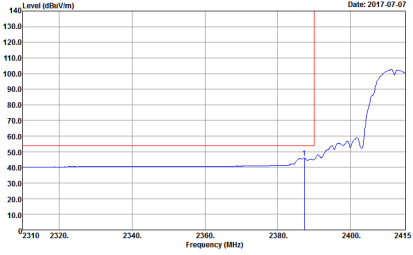
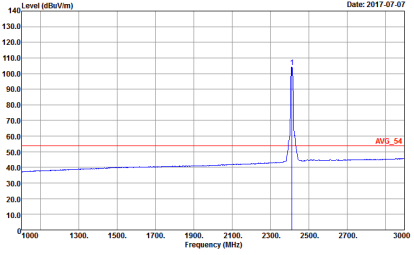
WIFI	2.4GHz 2400~2483.5MHz Band Edge @ 3m	
ANT	802.11b CH01 2412MHz	
1	Horizontal	Fundamental
Peak	 <p>Site : 03CH13-HY Condition : PEAK BE 74 3m HORN 9120d 1522 HORIZONTAL</p>	 <p>Site : 03CH13-HY Condition : PEAK 74 3m HORN 9120d 1522 HORIZONTAL</p>
Avg.	 <p>Site : 03CH13-HY Condition : AVG BE 54 3m HORN 9120d 1522 HORIZONTAL</p>	 <p>Site : 03CH13-HY Condition : AVG 54 3m HORN 9120d 1522 HORIZONTAL</p>

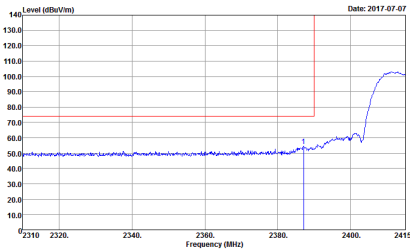
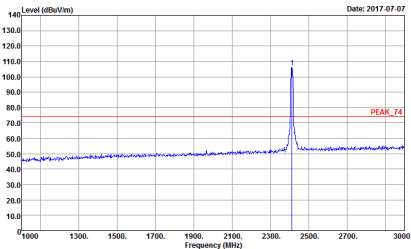
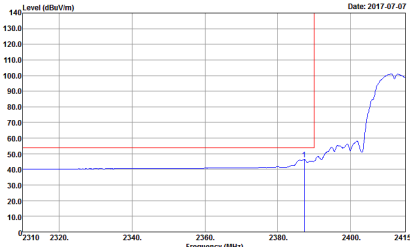
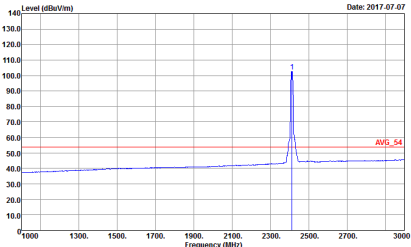

WIFI	2.4GHz 2400~2483.5MHz Band Edge @ 3m	
ANT	802.11b CH01 2412MHz	
1	Vertical	Fundamental
Peak	 <p>Date: 2017-07-07</p> <p>Site : 03CH13-HY Condition : PEAK BE 74 3m HORN 9120D 1522 VERTICAL</p>	 <p>Date: 2017-07-07</p> <p>Site : 03CH13-HY Condition : PEAK 74 3m HORN 9120D 1522 VERTICAL</p>
Avg.	 <p>Date: 2017-07-07</p> <p>Site : 03CH13-HY Condition : AV6 BE 54 3m HORN 9120D 1522 VERTICAL</p>	 <p>Date: 2017-07-07</p> <p>Site : 03CH13-HY Condition : AV6 54 3m HORN 9120D 1522 VERTICAL</p>

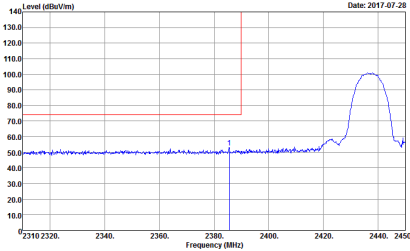
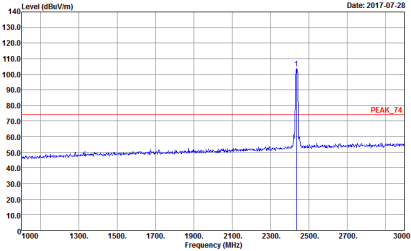
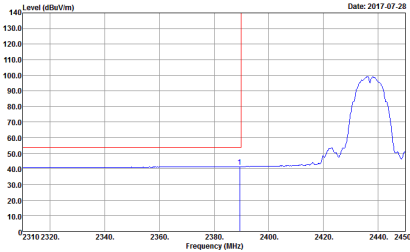
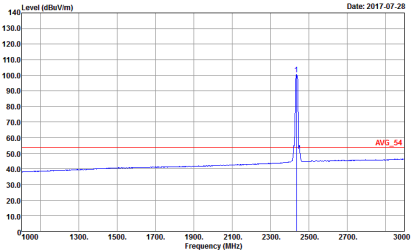

WIFI	2.4GHz 2400~2483.5MHz Band Edge @ 3m	
ANT	802.11b CH06 2437MHz - L	
1	Horizontal	Fundamental
Peak	 <p>Date: 2017-07-28</p> <p>Site : 03CH13-#Y Condition : PEAK_BE_74 3m HORN_9120D_1522 HORIZONTAL RBW:1000.000KHz VBW:3000.000KHz SWT:Auto Detector : Peak Project : 742534-01 Mode : 8</p>	 <p>Date: 2017-07-28</p> <p>Site : 03CH13-#Y Condition : PEAK_74 3m HORN_9120D_1522 HORIZONTAL RBW:1000.000KHz VBW:3000.000KHz SWT:Auto Detector : Peak Project : 742534-01 Mode : 8</p>
Avg.	 <p>Date: 2017-07-28</p> <p>Site : 03CH13-#Y Condition : AV6_BE_54 3m HORN_9120D_1522 HORIZONTAL RBW:1000.000KHz VBW:0.010KHz SWT:Auto Detector : Peak Project : 742534-01 Mode : 8</p>	 <p>Date: 2017-07-28</p> <p>Site : 03CH13-#Y Condition : AV6_54 3m HORN_9120D_1522 HORIZONTAL RBW:1000.000KHz VBW:0.010KHz SWT:Auto Detector : Peak Project : 742534-01 Mode : 8</p>



WIFI	2.4GHz 2400~2483.5MHz Band Edge @ 3m	
ANT	802.11b CH06 2437MHz - R	
1	Horizontal	Fundamental
Peak	<p>Site : 03CH13-HY Condition : PEAK_BE_74 3m HORN_9120D_1522 HORIZONTAL Detector : Peak Project : 742534-01 Mode : 8</p>	Left blank
Avg.	<p>Site : 03CH13-HY Condition : AVG_BE_54 3m HORN_9120D_1522 HORIZONTAL Detector : Peak Project : 742534-01 Mode : 8</p>	Left blank

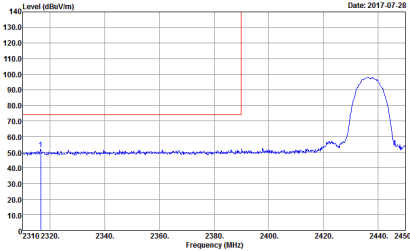
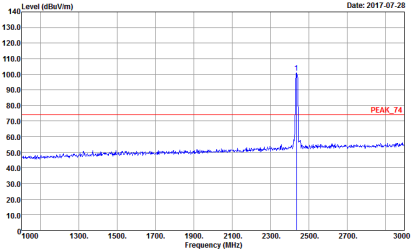
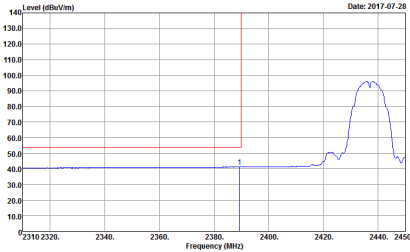
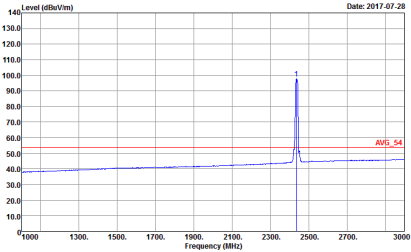

WIFI	2.4GHz 2400~2483.5MHz Band Edge @ 3m	
ANT	802.11b CH06 2437MHz - L	
1	Vertical	Fundamental
Peak	 <p>Site : 03CH13-HY Condition : PEAK_BE_74 3m HORN_9120D_1522 VERTICAL RBW:1000.000KHz VBW:3000.000KHz SWT:Auto Detector : Peak Project : 742534-01 Mode : 8</p>	 <p>Site : 03CH13-HY Condition : PEAK_74 3m HORN_9120D_1522 VERTICAL RBW:1000.000KHz VBW:3000.000KHz SWT:Auto Detector : Peak Project : 742534-01 Mode : 8</p>
Avg.	 <p>Site : 03CH13-HY Condition : AV6_BE_54 3m HORN_9120D_1522 VERTICAL RBW:1000.000KHz VBW:0.010KHz SWT:Auto Detector : Peak Project : 742534-01 Mode : 8</p>	 <p>Site : 03CH13-HY Condition : AV6_54 3m HORN_9120D_1522 VERTICAL RBW:1000.000KHz VBW:0.010KHz SWT:Auto Detector : Peak Project : 742534-01 Mode : 8</p>

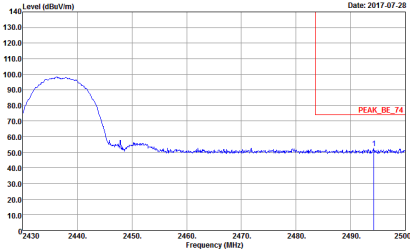
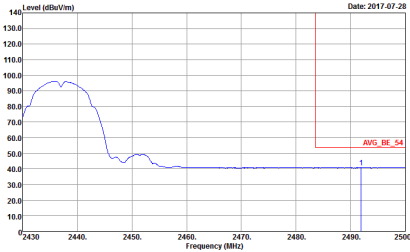

WIFI	2.4GHz 2400~2483.5MHz Band Edge @ 3m	
ANT	802.11b CH06 2437MHz - R	
1	Vertical	Fundamental
Peak	 <p> Date: 2017-07-28 Site : 03CH13-HY Condition : PEAK_BE_74 3m HORN_9120D_1522 VERTICAL Detector : Peak Project : 742534-01 Mode : 8 </p>	Left blank
Avg.	 <p> Date: 2017-07-28 Site : 03CH13-HY Condition : AVG_BE_54 3m HORN_9120D_1522 VERTICAL Detector : Peak Project : 742534-01 Mode : 8 </p>	Left blank

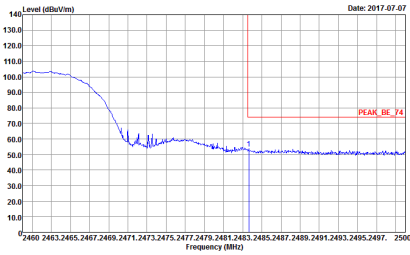
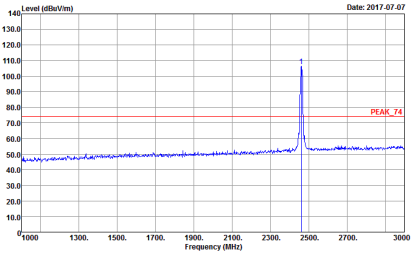
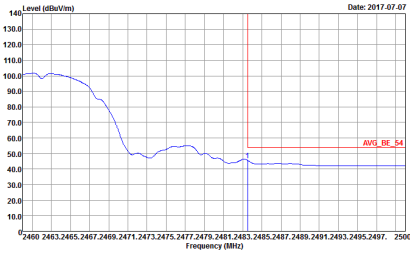
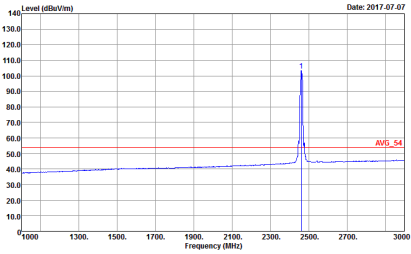

WIFI	2.4GHz 2400~2483.5MHz Band Edge @ 3m	
ANT	802.11b CH11 2462MHz	
1	Horizontal	Fundamental
Peak	 <p>Date: 2017-07-07</p> <p>Site : 03CH13-HY Condition : PEAK_BE_74 3m HORN 9120D 1522 HORIZONTAL</p>	 <p>Date: 2017-07-07</p> <p>Site : 03CH13-HY Condition : PEAK_74 3m HORN 9120D 1522 HORIZONTAL</p>
Avg.	 <p>Date: 2017-07-07</p> <p>Site : 03CH13-HY Condition : AVG_BE_54 3m HORN 9120D 1522 HORIZONTAL</p>	 <p>Date: 2017-07-07</p> <p>Site : 03CH13-HY Condition : AVG_54 3m HORN 9120D 1522 HORIZONTAL</p>



WIFI	2.4GHz 2400~2483.5MHz Band Edge @ 3m	
ANT	802.11b CH11 2462MHz	
1	Vertical	Fundamental
Peak	<p>Site : 03CH13-HY Condition : PEAK BE 74 3m HORN 9120D 1522 VERTICAL</p>	<p>Site : 03CH13-HY Condition : PEAK 74 3m HORN 9120D 1522 VERTICAL</p>
Avg.	<p>Site : 03CH13-HY Condition : AVG BE 54 3m HORN 9120D 1522 VERTICAL</p>	<p>Site : 03CH13-HY Condition : AVG 54 3m HORN 9120D 1522 VERTICAL</p>

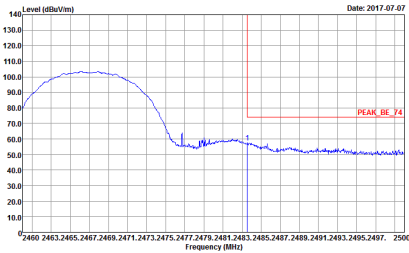
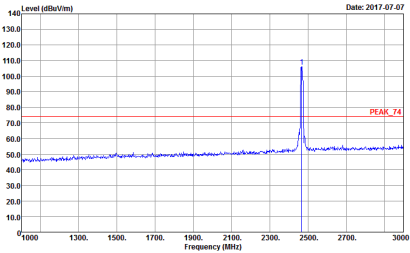
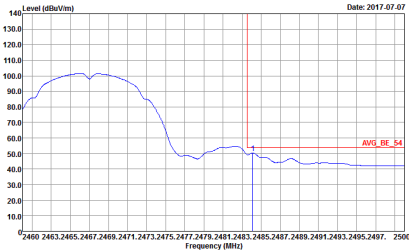
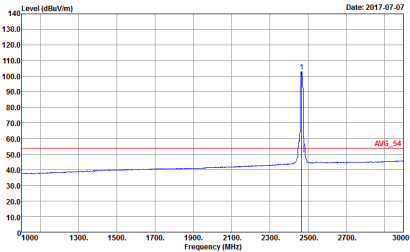

WIFI	2.4GHz 2400~2483.5MHz Band Edge @ 3m	
ANT	802.11b CH12 2467MHz	
1	Horizontal	Fundamental
Peak	 <p>Date: 2017-07-07</p> <p>Site : 03CH13-HY Condition : PEAK BE 74 3m HORN 9120D 1522 HORIZONTAL</p>	 <p>Date: 2017-07-07</p> <p>Site : 03CH13-HY Condition : PEAK 74 3m HORN 9120D 1522 HORIZONTAL</p>
Avg.	 <p>Date: 2017-07-07</p> <p>Site : 03CH13-HY Condition : AVG BE 54 3m HORN 9120D 1522 HORIZONTAL</p>	 <p>Date: 2017-07-07</p> <p>Site : 03CH13-HY Condition : AVG 54 3m HORN 9120D 1522 HORIZONTAL</p>

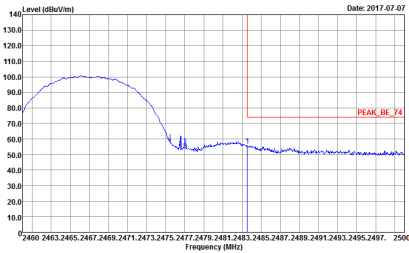
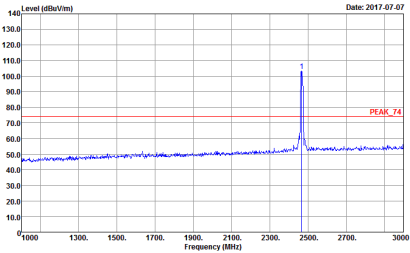
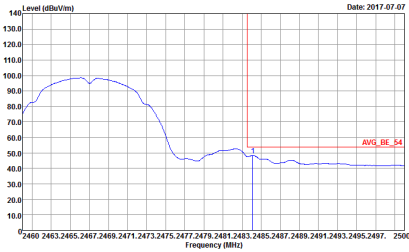
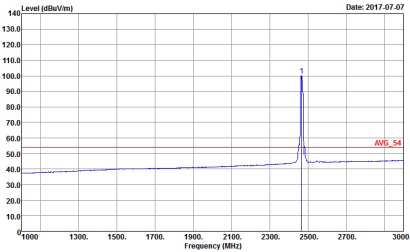

WIFI	2.4GHz 2400~2483.5MHz Band Edge @ 3m	
ANT	802.11b CH12 2467MHz	
1	Vertical	Fundamental
Peak	 <p>Date: 2017-07-07</p> <p>Site : 03CH13-HY Condition : PEAK_BE_74 3m HORN 9120D 1522 VERTICAL</p>	 <p>Date: 2017-07-07</p> <p>Site : 03CH13-HY Condition : PEAK_74 3m HORN 9120D 1522 VERTICAL</p>
Avg.	 <p>Date: 2017-07-07</p> <p>Site : 03CH13-HY Condition : AVG_BE_54 3m HORN 9120D 1522 VERTICAL</p>	 <p>Date: 2017-07-07</p> <p>Site : 03CH13-HY Condition : AVG_54 3m HORN 9120D 1522 VERTICAL</p>

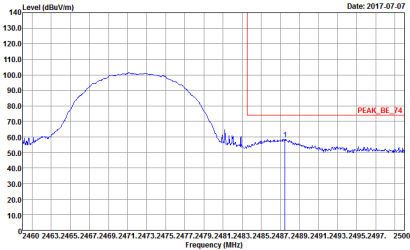
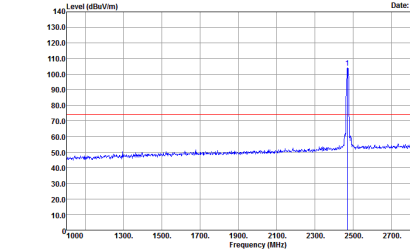
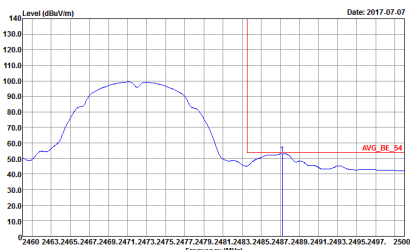
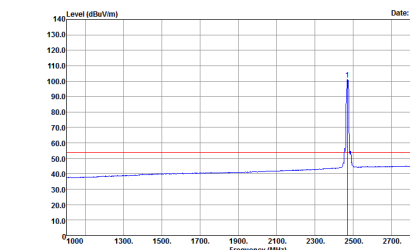

WIFI	2.4GHz 2400~2483.5MHz Band Edge @ 3m	
ANT	802.11b CH13 2472MHz	
1	Horizontal	Fundamental
Peak	 <p>Date: 2017-07-07</p> <p>Level (dBuV/m)</p> <p>Frequency (MHz)</p> <p>PEAK_BE_74</p> <p>Site : 03CH13-HY Condition : PEAK BE 74 3m HORN 9120D 1522 HORIZONTAL</p>	 <p>Date: 2017-07-07</p> <p>Level (dBuV/m)</p> <p>Frequency (MHz)</p> <p>PEAK_74</p> <p>Site : 03CH13-HY Condition : PEAK 74 3m HORN 9120D 1522 HORIZONTAL</p>
Avg.	 <p>Date: 2017-07-07</p> <p>Level (dBuV/m)</p> <p>Frequency (MHz)</p> <p>AVG_BE_54</p> <p>Site : 03CH13-HY Condition : AVG BE 54 3m HORN 9120D 1522 HORIZONTAL</p>	 <p>Date: 2017-07-07</p> <p>Level (dBuV/m)</p> <p>Frequency (MHz)</p> <p>AVG_54</p> <p>Site : 03CH13-HY Condition : AVG 54 3m HORN 9120D 1522 HORIZONTAL</p>

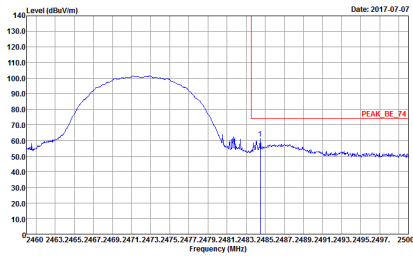
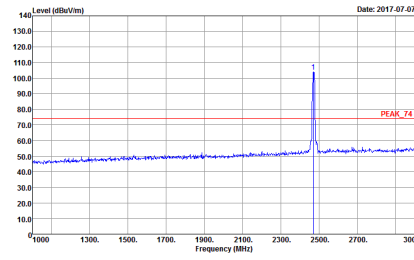
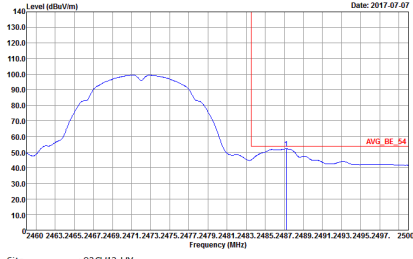
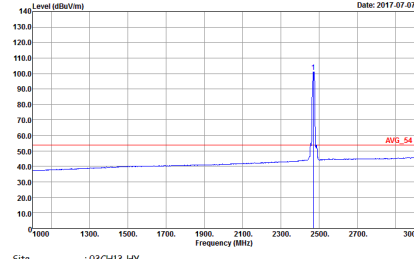

WIFI	2.4GHz 2400~2483.5MHz Band Edge @ 3m	
ANT	802.11b CH13 2472MHz	
1	Vertical	Fundamental
Peak	 <p>Date: 2017-07-07</p> <p>Site : 03CH13-HY Condition : PEAK_BE_74 3m HORN 9120D 1522 VERTICAL</p>	 <p>Date: 2017-07-07</p> <p>Site : 03CH13-HY Condition : PEAK_74 3m HORN 9120D 1522 VERTICAL</p>
Avg.	 <p>Date: 2017-07-07</p> <p>Site : 03CH13-HY Condition : AVG_BE_54 3m HORN 9120D 1522 VERTICAL</p>	 <p>Date: 2017-07-07</p> <p>Site : 03CH13-HY Condition : AVG_54 3m HORN 9120D 1522 VERTICAL</p>



2.4GHz 2400~2483.5MHz

WIFI 802.11b (Harmonic @ 3m)

WIFI	2.4GHz 2400~2483.5MHz Harmonic @ 3m	
ANT	802.11b CH01 2412MHz	
1	Horizontal	Vertical
Peak	<p>Site : 03CH13-HY Condition : PEAK 74 3m SHF HORN 584 HORIZONTAL</p>	<p>Site : 03CH13-HY Condition : PEAK 74 3m SHF HORN 584 VERTICAL</p>
Avg.		

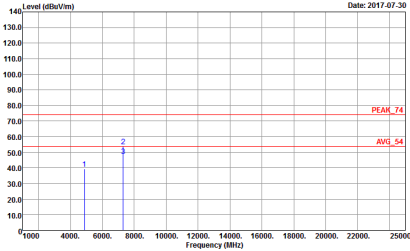
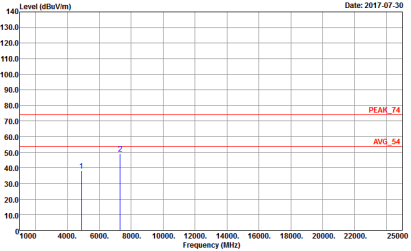

WIFI	2.4GHz 2400~2483.5MHz Harmonic @ 3m	
ANT	802.11b CH06 2437MHz	
1	Horizontal	Vertical
Peak Avg.	 <p>Site : 03CH13-#Y Condition : PEAK_74 3m SHF_HORN_584 HORIZONTAL Detector : Peak Project : 742534-01 Mode : 8</p>	 <p>Site : 03CH13-#Y Condition : PEAK_74 3m SHF_HORN_584 VERTICAL Detector : Peak Project : 742534-01 Mode : 8</p>



WIFI	2.4GHz 2400~2483.5MHz Harmonic @ 3m	
ANT	802.11b CH11 2462MHz	
1	Horizontal	Vertical
Peak Avg.	<p>Site : 03CH13-HY Condition : PEAK 74 3m SHF HORN 584 HORIZONTAL</p>	<p>Site : 03CH13-HY Condition : PEAK 74 3m SHF HORN 584 VERTICAL</p>



WIFI	2.4GHz 2400~2483.5MHz Harmonic @ 3m	
ANT	802.11b CH12 2467MHz	
1	Horizontal	Vertical
Peak Avg.	<p>Site : 03CH13-HY Condition : PEAK 74 3m SHF HORN 584 HORIZONTAL</p>	<p>Site : 03CH13-HY Condition : PEAK 74 3m SHF HORN 584 VERTICAL</p>



WIFI	2.4GHz 2400~2483.5MHz Harmonic @ 3m	
ANT	802.11b CH13 2472MHz	
1	Horizontal	Vertical
Peak Avg.	<p>Site : 03CH13-HY Condition : PEAK 74 3m SHF HORN 584 HORIZONTAL</p>	<p>Site : 03CH13-HY Condition : PEAK 74 3m SHF HORN 584 VERTICAL</p>

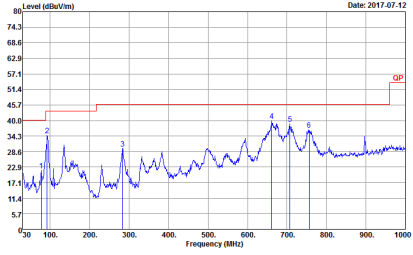
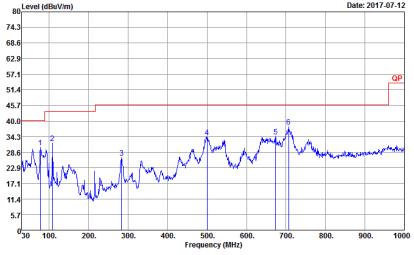

Emission below 1GHz
2.4GHz WIFI 802.11b (LF)

WIFI	2.4GHz 2400~2483.5MHz	
ANT	802.11b LF	
1	Horizontal	Vertical
<p>QP / Peak</p>	 <p>Site : 03GH13-4Y Condition : QP 3m SILEG 40103 HORIZONTAL</p>	 <p>Site : 03GH13-4Y Condition : QP 3m SILEG 40103 VERTICAL</p>



2.4GHz 2400~2483.5MHz

WIFI 802.11b (Band Edge @ 3m)

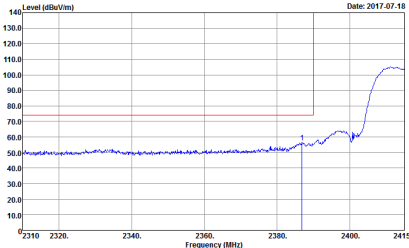
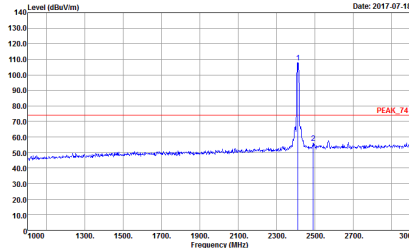
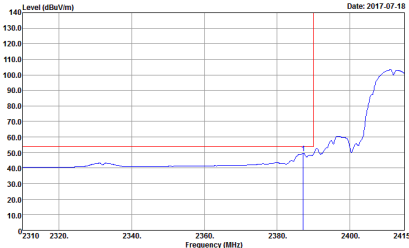
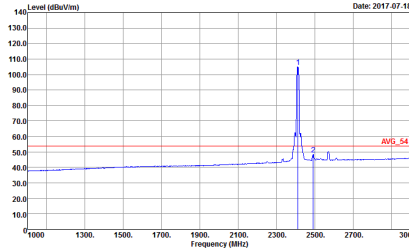
WIFI	2.4GHz 2400~2483.5MHz Band Edge @ 3m	
ANT	802.11b CH01 2412MHz	
2	Horizontal	Fundamental
Peak	 <p>Site : 03CH13-HY Condition : PEAK BE 74 3m HORN 9120D 1522 HORIZONTAL</p>	 <p>Site : 03CH13-HY Condition : PEAK 74 3m HORN 9120D 1522 HORIZONTAL</p>
Avg.	 <p>Site : 03CH13-HY Condition : AVG BE 54 3m HORN 9120D 1522 HORIZONTAL</p>	 <p>Site : 03CH13-HY Condition : AVG 54 3m HORN 9120D 1522 HORIZONTAL</p>



WIFI	2.4GHz 2400~2483.5MHz Band Edge @ 3m	
ANT	802.11b CH01 2412MHz	
2	Vertical	Fundamental
Peak	<p>Site : 03CH13-HY Condition : PEAK BE 74 3m HORN 9120D 1522 VERTICAL</p>	<p>Site : 03CH13-HY Condition : PEAK 74 3m HORN 9120D 1522 VERTICAL</p>
Avg.	<p>Site : 03CH13-HY Condition : AV6 BE 54 3m HORN 9120D 1522 VERTICAL</p>	<p>Site : 03CH13-HY Condition : AV6 54 3m HORN 9120D 1522 VERTICAL</p>

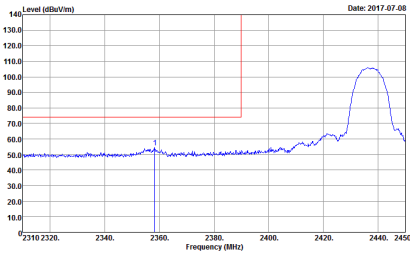
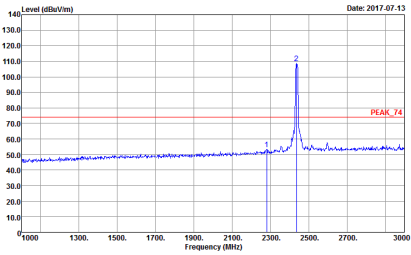
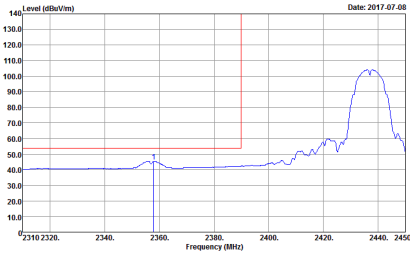
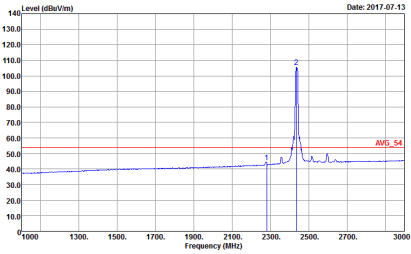

WIFI	2.4GHz 2400~2483.5MHz Band Edge @ 3m	
ANT	802.11b CH06 2437MHz - L	
2	Horizontal	Fundamental
Peak	 <p>Date: 2017-07-08</p> <p>Site : 03CH13-HY Condition : PEAK BE 74 3m HORN 9120D 1522 HORIZONTAL</p>	 <p>Date: 2017-07-13</p> <p>Site : 03CH13-HY Condition : PEAK 74 3m HORN 9120D 1522 HORIZONTAL</p>
Avg.	 <p>Date: 2017-07-08</p> <p>Site : 03CH13-HY Condition : AVG BE 54 3m HORN 9120D 1522 HORIZONTAL</p>	 <p>Date: 2017-07-13</p> <p>Site : 03CH13-HY Condition : AVG 54 3m HORN 9120D 1522 HORIZONTAL</p>



WIFI	2.4GHz 2400~2483.5MHz Band Edge @ 3m	
ANT	802.11b CH06 2437MHz - R	
2	Horizontal	Fundamental
Peak	<p>Date: 2017-07-08 Site : 03CH13-HY Condition : PEAK BE 74 3m HORN 9120D 1522 HORIZONTAL</p>	Left blank
Avg.	<p>Date: 2017-07-08 Site : 03CH13-HY Condition : AVG BE 54 3m HORN 9120D 1522 HORIZONTAL</p>	Left blank

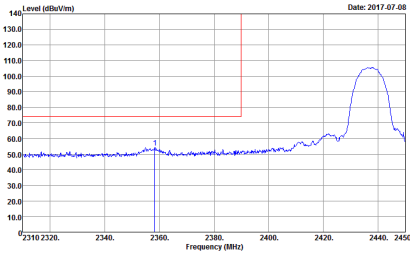
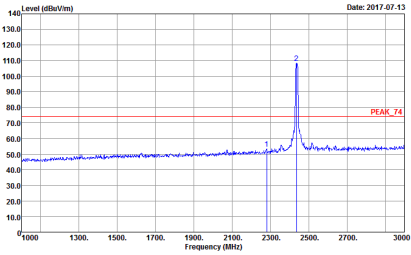
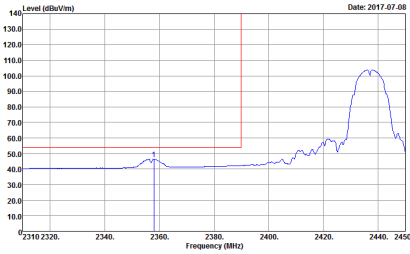
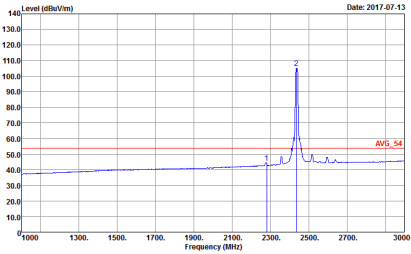

WIFI	2.4GHz 2400~2483.5MHz Band Edge @ 3m	
ANT	802.11b CH06 2437MHz - L	
2	Vertical	Fundamental
Peak	 <p>Date: 2017-07-08</p> <p>Site : 03CH13-HY Condition : PEAK BE 74 3m HORN 9120D 1522 VERTICAL</p>	 <p>Date: 2017-07-13</p> <p>Site : 03CH13-HY Condition : PEAK 74 3m HORN 9120D 1522 VERTICAL</p>
Avg.	 <p>Date: 2017-07-08</p> <p>Site : 03CH13-HY Condition : AVG BE 54 3m HORN 9120D 1522 VERTICAL</p>	 <p>Date: 2017-07-13</p> <p>Site : 03CH13-HY Condition : AVG 54 3m HORN 9120D 1522 VERTICAL</p>



WIFI	2.4GHz 2400~2483.5MHz Band Edge @ 3m	
ANT	802.11b CH06 2437MHz - R	
2	Vertical	Fundamental
Peak	<p>Date: 2017.07.08 PEAK_BE_74</p> <p>Site : 03CH13-HY Condition : PEAK_BE_74 3m HORN 9120D 1522 VERTICAL</p>	Left blank
Avg.	<p>Date: 2017.07.08 AVG_BE_54</p> <p>Site : 03CH13-HY Condition : AVG_BE_54 3m HORN 9120D 1522 VERTICAL</p>	Left blank

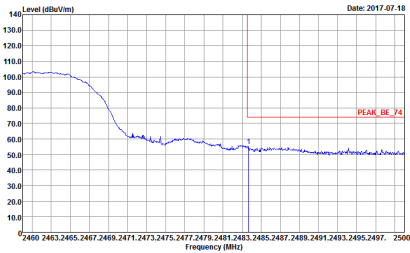
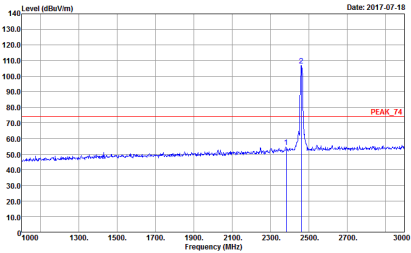
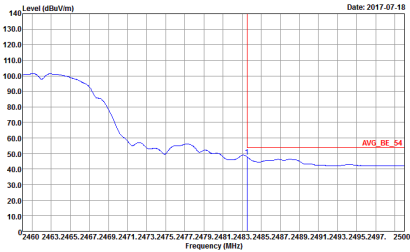
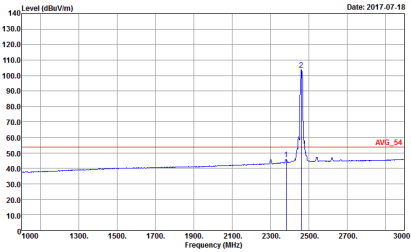

WIFI	2.4GHz 2400~2483.5MHz Band Edge @ 3m	
ANT	802.11b CH11 2462MHz	
2	Horizontal	Fundamental
Peak	 <p>Date: 2017-07-18</p> <p>Site : 03CH13-HY Condition : PEAK_BE_74 3m HORN 9120D 1522 HORIZONTAL</p>	 <p>Date: 2017-07-18</p> <p>Site : 03CH13-HY Condition : PEAK_74 3m HORN 9120D 1522 HORIZONTAL</p>
Avg.	 <p>Date: 2017-07-18</p> <p>Site : 03CH13-HY Condition : AVG_BE_54 3m HORN 9120D 1522 HORIZONTAL</p>	 <p>Date: 2017-07-18</p> <p>Site : 03CH13-HY Condition : AVG_54 3m HORN 9120D 1522 HORIZONTAL</p>

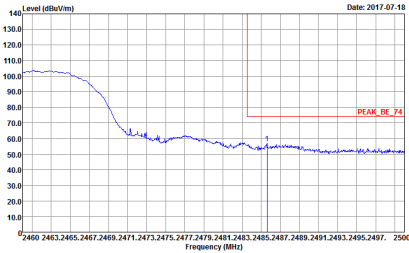
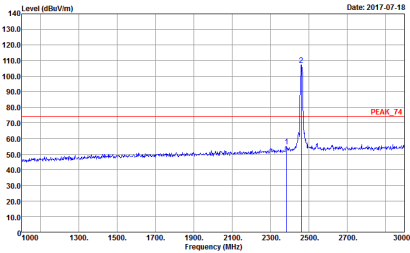
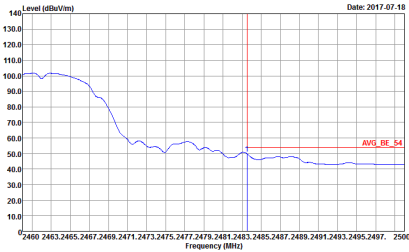
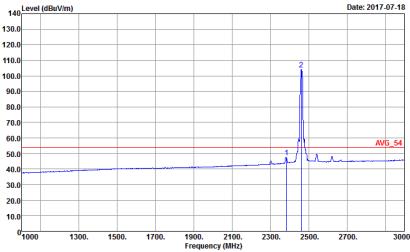

WIFI	2.4GHz 2400~2483.5MHz Band Edge @ 3m	
ANT	802.11b CH11 2462MHz	
2	Vertical	Fundamental
Peak	 <p>Date: 2017-07-18</p> <p>Site : 03CH13-HY Condition : PEAK_BE_74 3m HORN 9120D 1522 VERTICAL</p>	 <p>Date: 2017-07-18</p> <p>Site : 03CH13-HY Condition : PEAK_74 3m HORN 9120D 1522 VERTICAL</p>
Avg.	 <p>Date: 2017-07-18</p> <p>Site : 03CH13-HY Condition : AVG_BE_54 3m HORN 9120D 1522 VERTICAL</p>	 <p>Date: 2017-07-18</p> <p>Site : 03CH13-HY Condition : AVG_54 3m HORN 9120D 1522 VERTICAL</p>



WIFI	2.4GHz 2400~2483.5MHz Band Edge @ 3m	
ANT	802.11b CH12 2467MHz	
2	Horizontal	Fundamental
Peak	<p>Site : 03CH13-HY Condition : PEAK_BE_74 3m HORN 9120D 1522 HORIZONTAL</p>	<p>Site : 03CH13-HY Condition : PEAK_74 3m HORN 9120D 1522 HORIZONTAL</p>
Avg.	<p>Site : 03CH13-HY Condition : AV6_BE_54 3m HORN 9120D 1522 HORIZONTAL</p>	<p>Site : 03CH13-HY Condition : AV6_54 3m HORN 9120D 1522 HORIZONTAL</p>

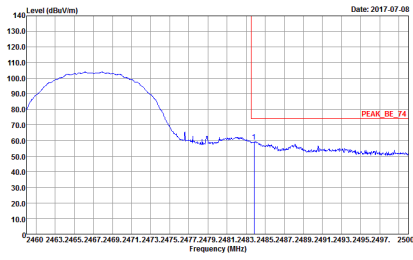
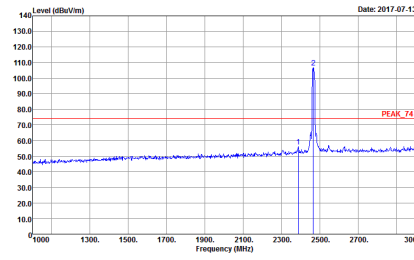
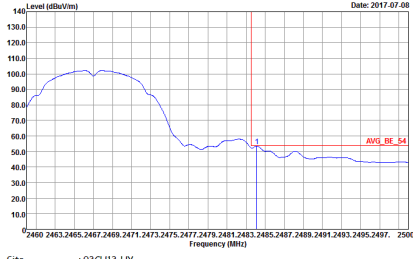
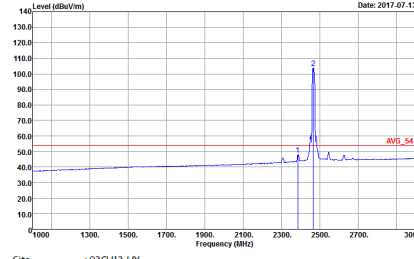

WIFI	2.4GHz 2400~2483.5MHz Band Edge @ 3m	
ANT	802.11b CH12 2467MHz	
2	Vertical	Fundamental
Peak	 <p>Date: 2017-07-08</p> <p>Site : 03CH13-HY Condition : PEAK_BE_74 3m HORN 9120D 1522 VERTICAL</p>	 <p>Date: 2017-07-13</p> <p>Site : 03CH13-HY Condition : PEAK_74 3m HORN 9120D 1522 VERTICAL</p>
Avg.	 <p>Date: 2017-07-08</p> <p>Site : 03CH13-HY Condition : AVG_BE_54 3m HORN 9120D 1522 VERTICAL</p>	 <p>Date: 2017-07-13</p> <p>Site : 03CH13-HY Condition : AVG_54 3m HORN 9120D 1522 VERTICAL</p>

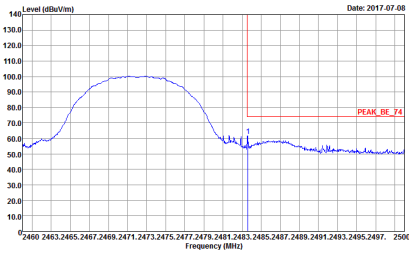
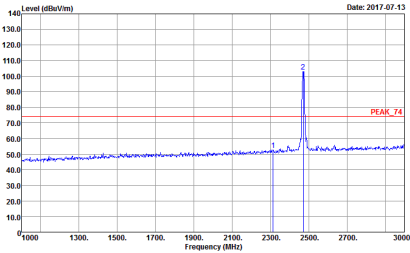
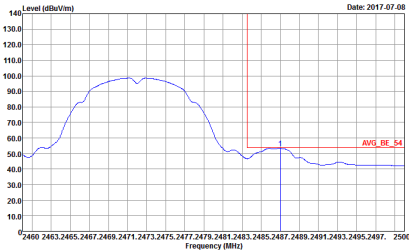
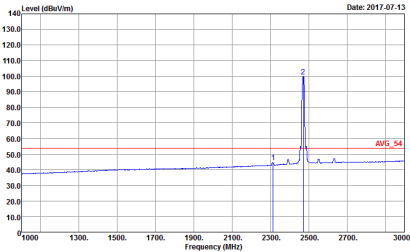

WIFI	2.4GHz 2400~2483.5MHz Band Edge @ 3m	
ANT	802.11b CH13 2472MHz	
2	Horizontal	Fundamental
Peak	 <p>Date: 2017-07-08</p> <p>Site : 03CH13-HY Condition : PEAK_BE_74 3m HORN 9120D 1522 HORIZONTAL</p>	 <p>Date: 2017-07-13</p> <p>Site : 03CH13-HY Condition : PEAK_74 3m HORN 9120D 1522 HORIZONTAL</p>
Avg.	 <p>Date: 2017-07-08</p> <p>Site : 03CH13-HY Condition : AVG_BE_54 3m HORN 9120D 1522 HORIZONTAL</p>	 <p>Date: 2017-07-13</p> <p>Site : 03CH13-HY Condition : AVG_54 3m HORN 9120D 1522 HORIZONTAL</p>



WIFI	2.4GHz 2400~2483.5MHz Band Edge @ 3m	
ANT	802.11b CH13 2472MHz	
2	Vertical	Fundamental
Peak	<p>Site : 03CH13-HY Condition : PEAK BE 74 3m HORN 9120D 1522 VERTICAL</p>	<p>Site : 03CH13-HY Condition : PEAK 74 3m HORN 9120D 1522 VERTICAL</p>
Avg.	<p>Site : 03CH13-HY Condition : AV6 BE 54 3m HORN 9120D 1522 VERTICAL</p>	<p>Site : 03CH13-HY Condition : AV6 54 3m HORN 9120D 1522 VERTICAL</p>



2.4GHz 2400~2483.5MHz

WIFI 802.11b (Harmonic @ 3m)

WIFI	2.4GHz 2400~2483.5MHz Harmonic @ 3m	
ANT	802.11b CH01 2412MHz	
2	Horizontal	Vertical
Peak Avg.	<p>Site : 03CH13-HY Condition : PEAK 74 3m SHF HORN 584 HORIZONTAL</p>	<p>Site : 03CH13-HY Condition : PEAK 74 3m SHF HORN 584 VERTICAL</p>

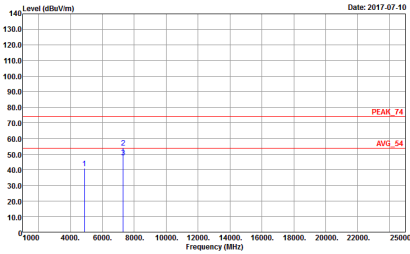
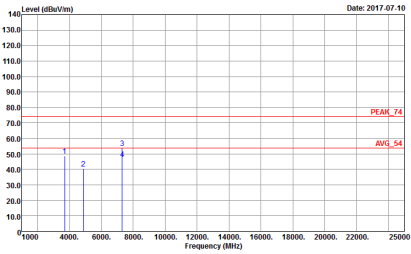

WIFI	2.4GHz 2400~2483.5MHz Harmonic @ 3m	
ANT	802.11b CH06 2437MHz	
2	Horizontal	Vertical
Peak Avg.	 <p>Site : 03CH13-HY Condition : PEAK_74 3m SHF HORN 584 HORIZONTAL</p>	 <p>Site : 03CH13-HY Condition : PEAK_74 3m SHF HORN 584 VERTICAL</p>

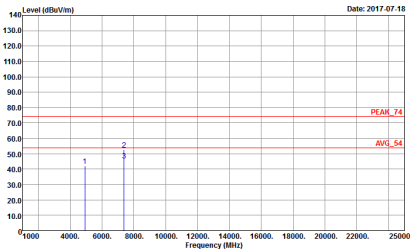
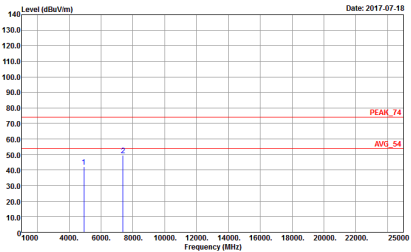

WIFI	2.4GHz 2400~2483.5MHz Harmonic @ 3m	
ANT	802.11b CH11 2462MHz	
2	Horizontal	Vertical
<p>Peak</p> <p>Avg.</p>	 <p>Site : 03CH13-HY Condition : PEAK 74 3m SHF HORN 584 HORIZONTAL</p>	 <p>Site : 03CH13-HY Condition : PEAK 74 3m SHF HORN 584 VERTICAL</p>

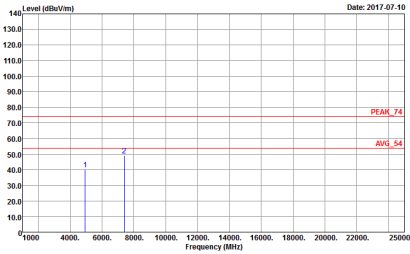
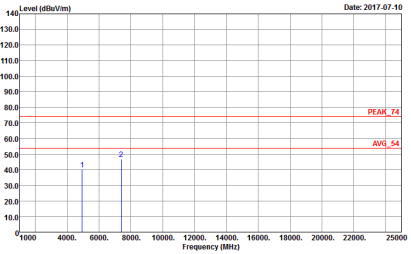

WIFI	2.4GHz 2400~2483.5MHz Harmonic @ 3m	
ANT	802.11b CH12 2467MHz	
2	Horizontal	Vertical
<p>Peak</p> <p>Avg.</p>	 <p>Site : 03CH13-HY Condition : PEAK 74 3m SHF HORN 584 HORIZONTAL</p>	 <p>Site : 03CH13-HY Condition : PEAK 74 3m SHF HORN 584 VERTICAL</p>

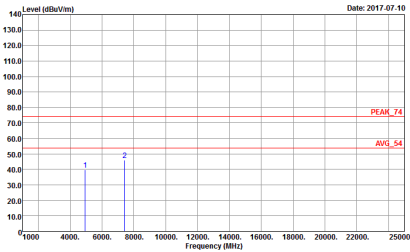
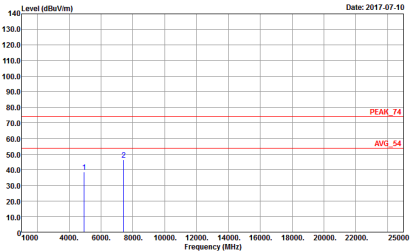

WIFI	2.4GHz 2400~2483.5MHz Harmonic @ 3m	
ANT	802.11b CH13 2472MHz	
2	Horizontal	Vertical
<p>Peak</p> <p>Avg.</p>	 <p>Site : 03CH13-HY Condition : PEAK 74 3m SHF HORN 584 HORIZONTAL</p>	 <p>Site : 03CH13-HY Condition : PEAK 74 3m SHF HORN 584 VERTICAL</p>



Emission below 1GHz
2.4GHz WIFI 802.11b (LF)

WIFI	2.4GHz 2400~2483.5MHz	
ANT	802.11b LF	
2	Horizontal	Vertical
QP / Peak	<p>Site : 03CH13-HY Condition : QP 3m BILOG 40103 HORIZONTAL</p>	<p>Site : 03CH13-HY Condition : QP 3m BILOG 40103 VERTICAL</p>



2.4GHz 2400~2483.5MHz

WIFI 802.11g (Band Edge @ 3m)

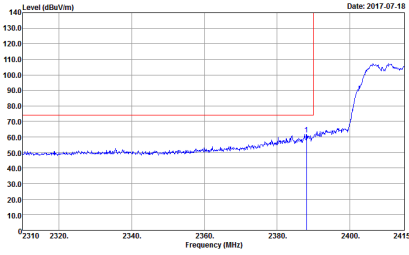
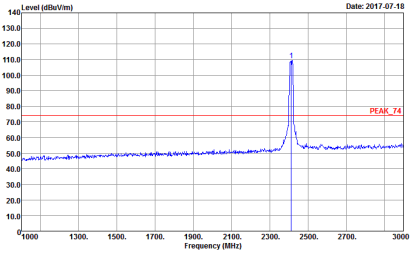
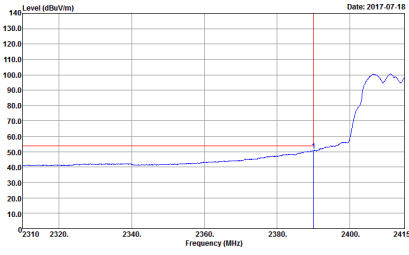
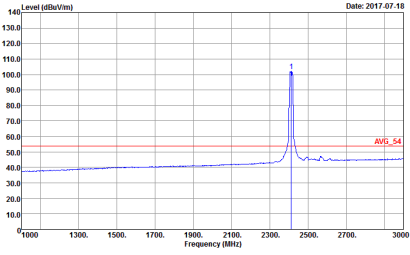
WIFI	2.4GHz 2400~2483.5MHz Band Edge @ 3m	
ANT	802.11g CH01 2412MHz	
1+2	Horizontal	Fundamental
Peak	 <p>Date: 2017-07-18</p> <p>Site : 03CH13-HY Condition : PEAK BE 74 3m HORN 9120D 1522 HORIZONTAL</p>	 <p>Date: 2017-07-18</p> <p>Site : 03CH13-HY Condition : PEAK 74 3m HORN 9120D 1522 HORIZONTAL</p>
Avg.	 <p>Date: 2017-07-18</p> <p>Site : 03CH13-HY Condition : AVG BE 54 3m HORN 9120D 1522 HORIZONTAL</p>	 <p>Date: 2017-07-18</p> <p>Site : 03CH13-HY Condition : AVG 54 3m HORN 9120D 1522 HORIZONTAL</p>



WIFI	2.4GHz 2400~2483.5MHz Band Edge @ 3m	
ANT	802.11g CH01 2412MHz	
1+2	Vertical	Fundamental
Peak	<p>Level (dBuV/m) Date: 2017-07-18</p> <p>Site : 03CH13-HY Condition : PEAK BE 74 3m HORN 9120D 1522 VERTICAL</p>	<p>Level (dBuV/m) Date: 2017-07-18</p> <p>Site : 03CH13-HY Condition : PEAK 74 3m HORN 9120D 1522 VERTICAL</p>
Avg.	<p>Level (dBuV/m) Date: 2017-07-18</p> <p>Site : 03CH13-HY Condition : AVG BE 54 3m HORN 9120D 1522 VERTICAL</p>	<p>Level (dBuV/m) Date: 2017-07-18</p> <p>Site : 03CH13-HY Condition : AVG 54 3m HORN 9120D 1522 VERTICAL</p>

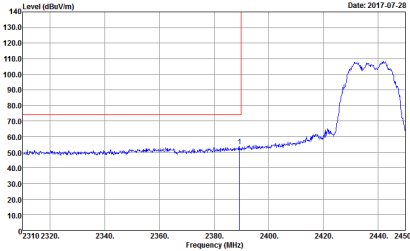
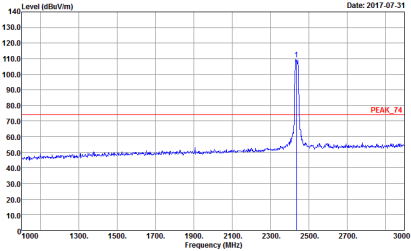
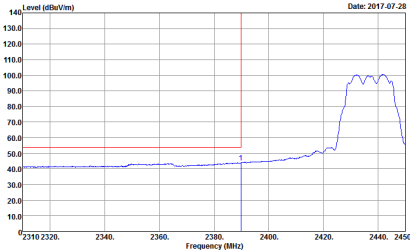
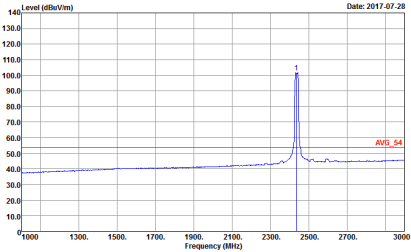

WIFI	2.4GHz 2400~2483.5MHz Band Edge @ 3m	
ANT	802.11g CH06 2437MHz - L	
1+2	Horizontal	Fundamental
Peak	 <p>Date: 2017-07-28</p> <p>Site : 03CH13-#Y Condition : PEAK_BE_74 3m HORN_9120D_1522 HORIZONTAL RBW:1000.000KHz VBW:3000.000KHz SWT:Auto Detector : Peak Project : 742534-01 Mode : 1B</p>	 <p>Date: 2017-07-31</p> <p>Site : 03CH13-#Y Condition : PEAK_74 3m HORN_9120D_1522 HORIZONTAL RBW:1000.000KHz VBW:3000.000KHz SWT:Auto Detector : Peak Project : 742534-01 Mode : 1B</p>
Avg.	 <p>Date: 2017-07-28</p> <p>Site : 03CH13-#Y Condition : AV6_BE_54 3m HORN_9120D_1522 HORIZONTAL RBW:1000.000KHz VBW:1000KHz SWT:Auto Detector : Peak Project : 742534-01 Mode : 1B</p>	 <p>Date: 2017-07-28</p> <p>Site : 03CH13-#Y Condition : AV6_54 3m HORN_9120D_1522 HORIZONTAL RBW:1000.000KHz VBW:1000KHz SWT:Auto Detector : Peak Project : 742534-01 Mode : 1B</p>

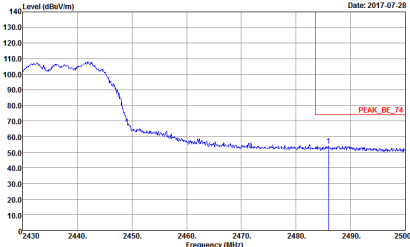
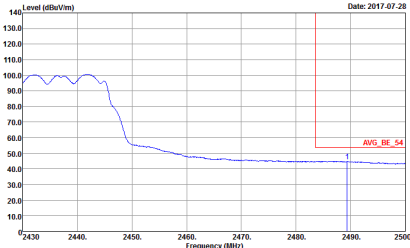

WIFI	2.4GHz 2400~2483.5MHz Band Edge @ 3m	
ANT	802.11g CH06 2437MHz - R	
1+2	Horizontal	Fundamental
Peak	 <p> Date: 2017-07-28 Site : 03CH13-HY Condition : PEAK_BE_74 3m HORN_9120D_1522 HORIZONTAL Detector : Peak Project : 742534-01 Mode : 1B </p>	Left blank
Avg.	 <p> Date: 2017-07-28 Site : 03CH13-HY Condition : AVG_BE_54 3m HORN_9120D_1522 HORIZONTAL Detector : Peak Project : 742534-01 Mode : 1B </p>	Left blank

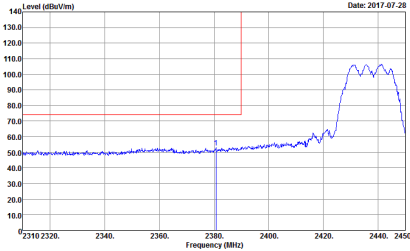
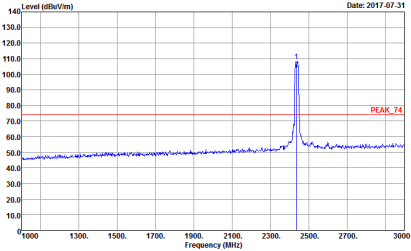
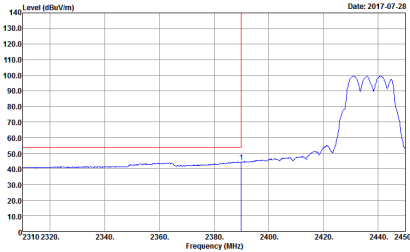
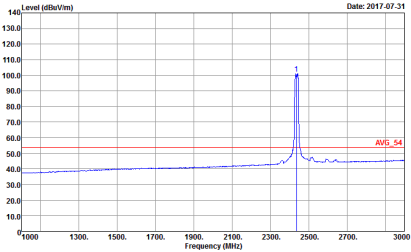

WIFI	2.4GHz 2400~2483.5MHz Band Edge @ 3m	
ANT	802.11g CH06 2437MHz - L	
1+2	Vertical	Fundamental
Peak	 <p>Date: 2017-07-28</p> <p>Site : 03CH13-#Y Condition : PEAK_BE_74 3m HORN_9120D_1522 VERTICAL RBW:1000.000KHz VBW:3000.000KHz SWT:Auto Detector : Peak Project : 742534-01 Mode : 1B</p>	 <p>Date: 2017-07-31</p> <p>Site : 03CH13-#Y Condition : PEAK_74 3m HORN_9120D_1522 VERTICAL RBW:1000.000KHz VBW:3000.000KHz SWT:Auto Detector : Peak Project : 742534-01 Mode : 1B</p>
Avg.	 <p>Date: 2017-07-28</p> <p>Site : 03CH13-#Y Condition : AV6_BE_54 3m HORN_9120D_1522 VERTICAL RBW:1000.000KHz VBW:1000KHz SWT:Auto Detector : Peak Project : 742534-01 Mode : 1B</p>	 <p>Date: 2017-07-31</p> <p>Site : 03CH13-#Y Condition : AV6_54 3m HORN_9120D_1522 VERTICAL RBW:1000.000KHz VBW:1000KHz SWT:Auto Detector : Peak Project : 742534-01 Mode : 1B</p>

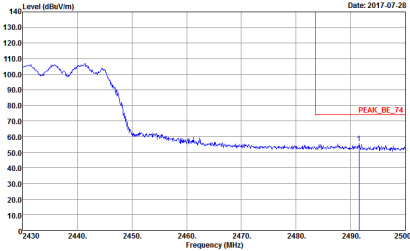
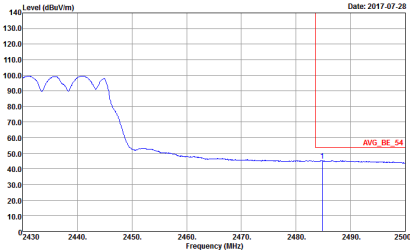

WIFI	2.4GHz 2400~2483.5MHz Band Edge @ 3m	
ANT	802.11g CH06 2437MHz - R	
1+2	Vertical	Fundamental
Peak	 <p>Date: 2017-07-28</p> <p>Site : 03CH13-HY Condition : PEAK_BE_74 3m HORN_9120D_1522 VERTICAL RBW:1000.000KHz VBW:3000.000KHz SWT:Auto Detector : Peak Project : 742534-01 Mode : 1B</p>	Left Blank
Avg.	 <p>Date: 2017-07-28</p> <p>Site : 03CH13-HY Condition : AVG_BE_54 3m HORN_9120D_1522 VERTICAL RBW:1000.000KHz VBW:1000KHz SWT:Auto Detector : Peak Project : 742534-01 Mode : 1B</p>	Left Blank

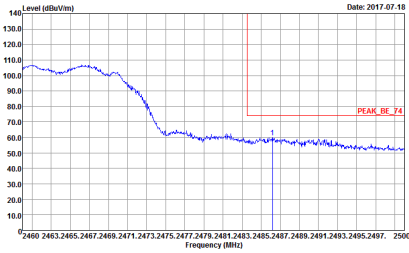
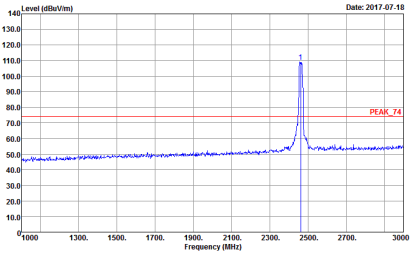
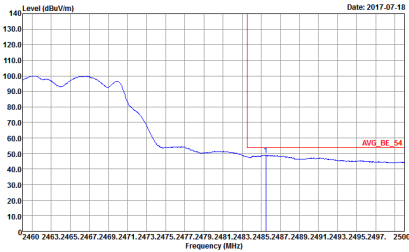
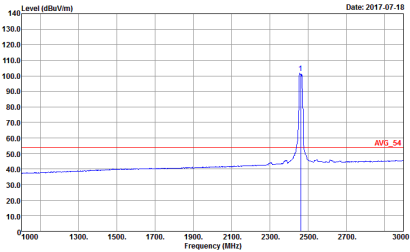

WIFI	2.4GHz 2400~2483.5MHz Band Edge @ 3m	
ANT	802.11g CH11 2462MHz	
1+2	Horizontal	Fundamental
Peak	 <p>Date: 2017-07-18</p> <p>Site : 03CH13-HY Condition : PEAK_BE_74 3m HORN 9120D 1522 HORIZONTAL</p>	 <p>Date: 2017-07-18</p> <p>Site : 03CH13-HY Condition : PEAK_74 3m HORN 9120D 1522 HORIZONTAL</p>
Avg.	 <p>Date: 2017-07-18</p> <p>Site : 03CH13-HY Condition : AVG_BE_54 3m HORN 9120D 1522 HORIZONTAL</p>	 <p>Date: 2017-07-18</p> <p>Site : 03CH13-HY Condition : AVG_54 3m HORN 9120D 1522 HORIZONTAL</p>

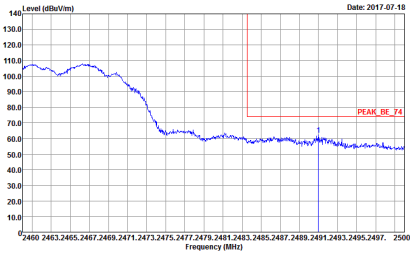
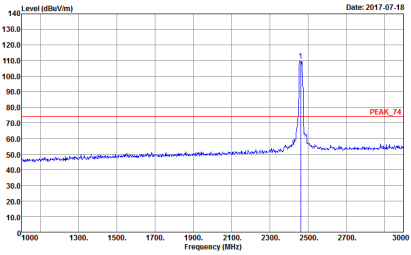
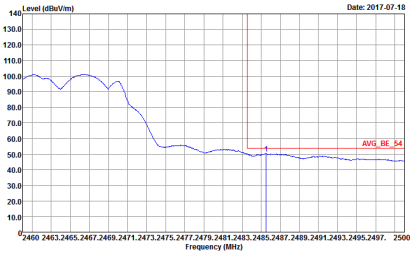
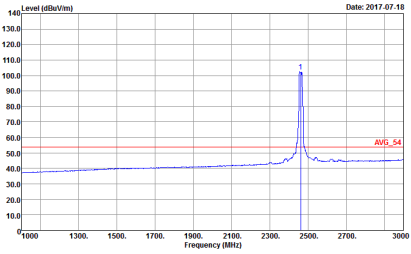

WIFI	2.4GHz 2400~2483.5MHz Band Edge @ 3m	
ANT	802.11g CH11 2462MHz	
1+2	Vertical	Fundamental
Peak	 <p>Date: 2017-07-18</p> <p>Site : 03CH13-HY Condition : PEAK_BE_74 3m HORN 9120D 1522 VERTICAL</p>	 <p>Date: 2017-07-18</p> <p>Site : 03CH13-HY Condition : PEAK_74 3m HORN 9120D 1522 VERTICAL</p>
Avg.	 <p>Date: 2017-07-18</p> <p>Site : 03CH13-HY Condition : AVG_BE_54 3m HORN 9120D 1522 VERTICAL</p>	 <p>Date: 2017-07-18</p> <p>Site : 03CH13-HY Condition : AVG_54 3m HORN 9120D 1522 VERTICAL</p>

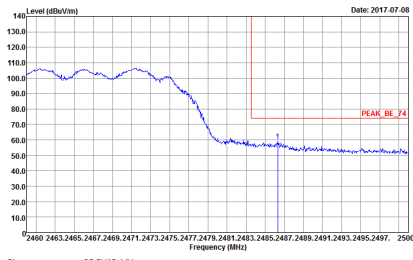
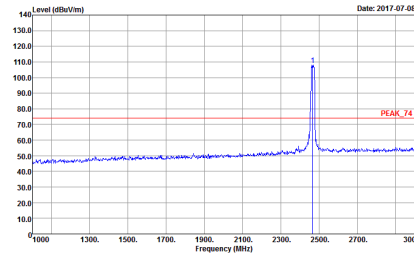
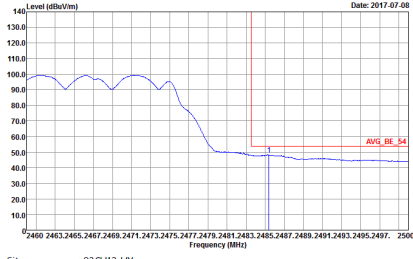
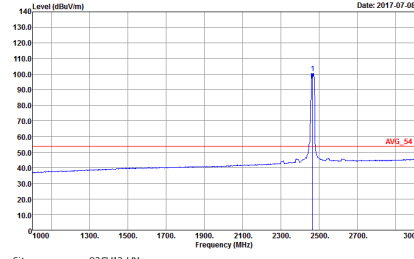

WIFI	2.4GHz 2400~2483.5MHz Band Edge @ 3m	
ANT	802.11g CH12 2467MHz	
1+2	Horizontal	Fundamental
Peak	 <p>Date: 2017-07-08</p> <p>Site : 03CH13-HY Condition : PEAK BE 74 3m HORN 9120D 1522 HORIZONTAL</p>	 <p>Date: 2017-07-08</p> <p>Site : 03CH13-HY Condition : PEAK 74 3m HORN 9120D 1522 HORIZONTAL</p>
Avg.	 <p>Date: 2017-07-08</p> <p>Site : 03CH13-HY Condition : AVG BE 54 3m HORN 9120D 1522 HORIZONTAL</p>	 <p>Date: 2017-07-08</p> <p>Site : 03CH13-HY Condition : AVG 54 3m HORN 9120D 1522 HORIZONTAL</p>

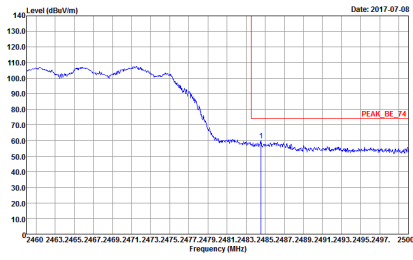
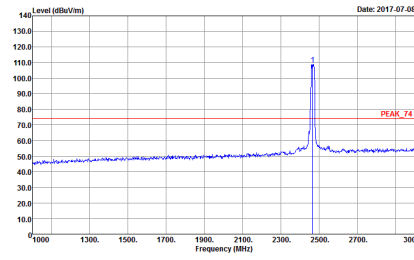
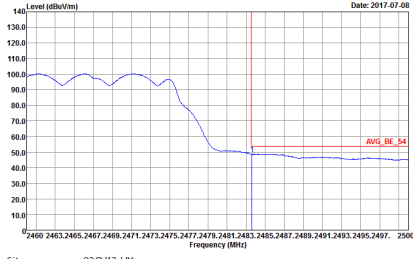
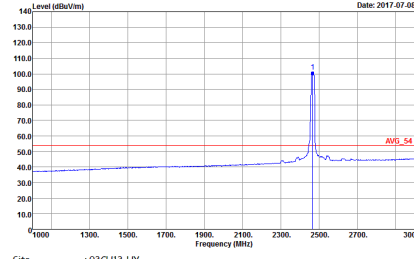

WIFI	2.4GHz 2400~2483.5MHz Band Edge @ 3m	
ANT	802.11g CH12 2467MHz	
1+2	Vertical	Fundamental
Peak	 <p>Date: 2017-07-08</p> <p>Site : 03CH13-HY Condition : PEAK BE 74 3m HORN 9120D 1522 VERTICAL</p>	 <p>Date: 2017-07-08</p> <p>Site : 03CH13-HY Condition : PEAK 74 3m HORN 9120D 1522 VERTICAL</p>
Avg.	 <p>Date: 2017-07-08</p> <p>Site : 03CH13-HY Condition : AVG BE 54 3m HORN 9120D 1522 VERTICAL</p>	 <p>Date: 2017-07-08</p> <p>Site : 03CH13-HY Condition : AVG 54 3m HORN 9120D 1522 VERTICAL</p>

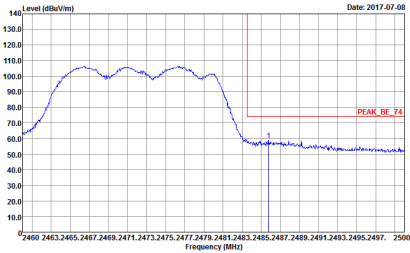
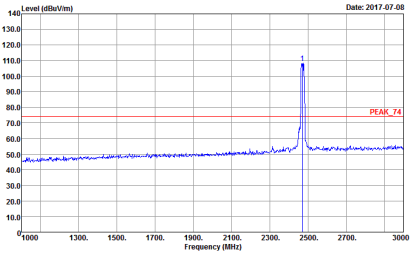
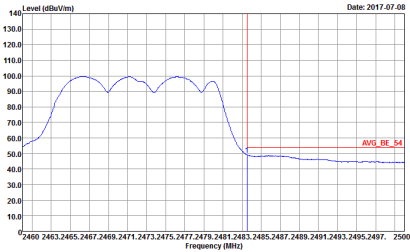
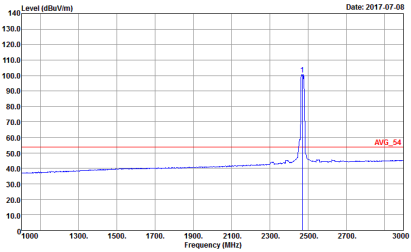

WIFI	2.4GHz 2400~2483.5MHz Band Edge @ 3m	
ANT	802.11g CH13 2472MHz	
1+2	Horizontal	Fundamental
Peak	 <p>Date: 2017-07-08</p> <p>Site : 03CH13-HY Condition : PEAK_BE_74 3m HORN 9120D 1522 HORIZONTAL</p>	 <p>Date: 2017-07-08</p> <p>Site : 03CH13-HY Condition : PEAK_74 3m HORN 9120D 1522 HORIZONTAL</p>
Avg.	 <p>Date: 2017-07-08</p> <p>Site : 03CH13-HY Condition : AVG_BE_54 3m HORN 9120D 1522 HORIZONTAL</p>	 <p>Date: 2017-07-08</p> <p>Site : 03CH13-HY Condition : AVG_54 3m HORN 9120D 1522 HORIZONTAL</p>



WIFI	2.4GHz 2400~2483.5MHz Band Edge @ 3m	
ANT	802.11g CH13 2472MHz	
1+2	Vertical	Fundamental
Peak	<p>Site : 03CH13-HY Condition : PEAK BE 74 3m HORN 9120D 1522 VERTICAL</p>	<p>Site : 03CH13-HY Condition : PEAK 74 3m HORN 9120D 1522 VERTICAL</p>
Avg.	<p>Site : 03CH13-HY Condition : AV6 BE 54 3m HORN 9120D 1522 VERTICAL</p>	<p>Site : 03CH13-HY Condition : AV6 54 3m HORN 9120D 1522 VERTICAL</p>



2.4GHz 2400~2483.5MHz

WIFI 802.11n HT20 (Band Edge @ 3m)

WIFI	2.4GHz 2400~2483.5MHz Band Edge @ 3m	
ANT	802.11n HT20 CH01 2412MHz	
1+2	Horizontal	Fundamental
Peak	<p>Site : 03CH13-HY Condition : PEAK BE 74 3m HORN 9120D 1522 HORIZONTAL</p>	<p>Site : 03CH13-HY Condition : PEAK 74 3m HORN 9120D 1522 HORIZONTAL</p>
Avg.	<p>Site : 03CH13-HY Condition : AVG BE 54 3m HORN 9120D 1522 HORIZONTAL</p>	<p>Site : 03CH13-HY Condition : AVG 54 3m HORN 9120D 1522 HORIZONTAL</p>



WIFI	2.4GHz 2400~2483.5MHz Band Edge @ 3m	
ANT	802.11n HT20 CH01 2412MHz	
1+2	Vertical	Fundamental
Peak	<p>Level (dBuV/m) vs Frequency (MHz) plot for Peak Vertical. The plot shows a signal level around 50 dBuV/m from 2310 to 2380 MHz, which then rises to approximately 100 dBuV/m between 2400 and 2415 MHz. A red vertical line is at 2412 MHz. Date: 2017-07-18.</p> <p>Site : 03CH13-HY Condition : PEAK BE 74 3m HORN 9120D 1522 VERTICAL</p>	<p>Level (dBuV/m) vs Frequency (MHz) plot for Peak Fundamental. The plot shows a sharp peak at approximately 2412 MHz with a level of about 110 dBuV/m. A red horizontal line labeled 'PEAK_74' is at approximately 75 dBuV/m. Date: 2017-07-18.</p> <p>Site : 03CH13-HY Condition : PEAK 74 3m HORN 9120D 1522 VERTICAL</p>
Avg.	<p>Level (dBuV/m) vs Frequency (MHz) plot for Avg Vertical. The plot shows a signal level around 40 dBuV/m from 2310 to 2380 MHz, which then rises to approximately 90 dBuV/m between 2400 and 2415 MHz. A red vertical line is at 2412 MHz. Date: 2017-07-18.</p> <p>Site : 03CH13-HY Condition : AVG BE 54 3m HORN 9120D 1522 VERTICAL</p>	<p>Level (dBuV/m) vs Frequency (MHz) plot for Avg Fundamental. The plot shows a sharp peak at approximately 2412 MHz with a level of about 100 dBuV/m. A red horizontal line labeled 'AVG_54' is at approximately 55 dBuV/m. Date: 2017-07-18.</p> <p>Site : 03CH13-HY Condition : AVG 54 3m HORN 9120D 1522 VERTICAL</p>

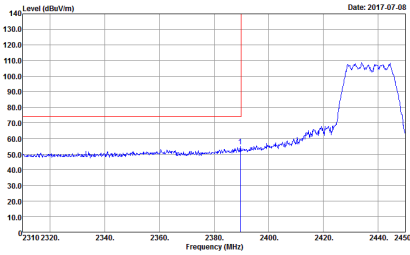
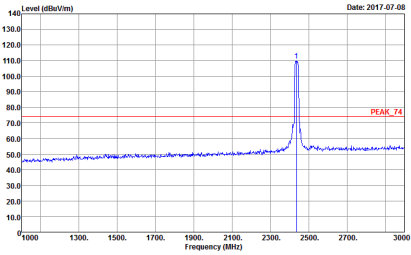
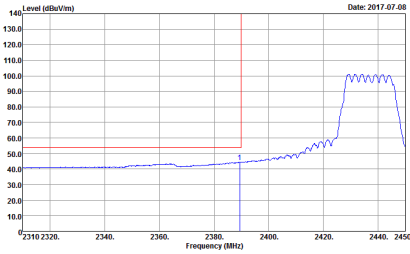
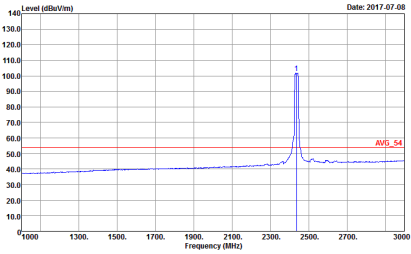

WIFI	2.4GHz 2400~2483.5MHz Band Edge @ 3m	
ANT	802.11n HT20 CH06 2437MHz - L	
1+2	Horizontal	Fundamental
Peak	 <p>Date: 2017-07-08</p> <p>Site : 03CH13-HY Condition : PEAK BE 74 3m HORN 9120D 1522 HORIZONTAL</p>	 <p>Date: 2017-07-08</p> <p>Site : 03CH13-HY Condition : PEAK 74 3m HORN 9120D 1522 HORIZONTAL</p>
Avg.	 <p>Date: 2017-07-08</p> <p>Site : 03CH13-HY Condition : AV6 BE 54 3m HORN 9120D 1522 HORIZONTAL</p>	 <p>Date: 2017-07-08</p> <p>Site : 03CH13-HY Condition : AV6 54 3m HORN 9120D 1522 HORIZONTAL</p>

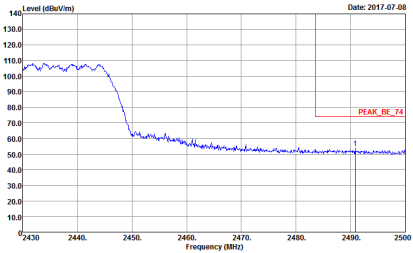
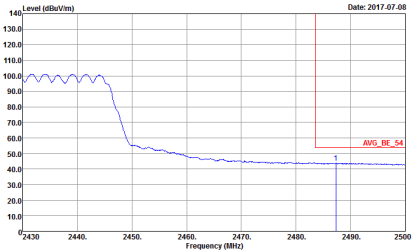

WIFI	2.4GHz 2400~2483.5MHz Band Edge @ 3m	
ANT	802.11n HT20 CH06 2437MHz - R	
1+2	Horizontal	Fundamental
Peak	 <p>Date: 2017-07-08</p> <p>Site : 03CH13-HY Condition : PEAK_BE_74 3m HORN 9120D 1522 HORIZONTAL</p>	Left blank
Avg.	 <p>Date: 2017-07-08</p> <p>Site : 03CH13-HY Condition : AVG_BE_54 3m HORN 9120D 1522 HORIZONTAL</p>	Left blank



WIFI	2.4GHz 2400~2483.5MHz Band Edge @ 3m	
ANT	802.11n HT20 CH06 2437MHz - L	
1+2	Vertical	Fundamental
Peak	<p>Level (dBuV/m) vs Frequency (MHz) plot for Vertical. The y-axis ranges from 10.0 to 140.0 dBuV/m, and the x-axis ranges from 2310 to 2450 MHz. A red horizontal line is at approximately 75 dBuV/m. A blue signal line shows a rising edge starting around 2420 MHz, peaking at approximately 110 dBuV/m around 2440 MHz. A vertical red line is at 2380 MHz. Date: 2017-07-08.</p> <p>Site : 03CH13-HY Condition : PEAK BE 74 3m HORN 9120D 1522 VERTICAL</p>	<p>Level (dBuV/m) vs Frequency (MHz) plot for Fundamental. The y-axis ranges from 10.0 to 140.0 dBuV/m, and the x-axis ranges from 1000 to 3000 MHz. A red horizontal line is at approximately 75 dBuV/m. A blue signal line shows a sharp peak at approximately 2437 MHz, reaching about 110 dBuV/m. A vertical red line is at 2437 MHz. Date: 2017-07-08.</p> <p>Site : 03CH13-HY Condition : PEAK 74 3m HORN 9120D 1522 VERTICAL</p>
Avg.	<p>Level (dBuV/m) vs Frequency (MHz) plot for Vertical. The y-axis ranges from 10.0 to 140.0 dBuV/m, and the x-axis ranges from 2310 to 2450 MHz. A red horizontal line is at approximately 55 dBuV/m. A blue signal line shows a rising edge starting around 2420 MHz, peaking at approximately 100 dBuV/m around 2440 MHz. A vertical red line is at 2380 MHz. Date: 2017-07-08.</p> <p>Site : 03CH13-HY Condition : AV6 BE 54 3m HORN 9120D 1522 VERTICAL</p>	<p>Level (dBuV/m) vs Frequency (MHz) plot for Fundamental. The y-axis ranges from 10.0 to 140.0 dBuV/m, and the x-axis ranges from 1000 to 3000 MHz. A red horizontal line is at approximately 55 dBuV/m. A blue signal line shows a sharp peak at approximately 2437 MHz, reaching about 100 dBuV/m. A vertical red line is at 2437 MHz. Date: 2017-07-08.</p> <p>Site : 03CH13-HY Condition : AV6 54 3m HORN 9120D 1522 VERTICAL</p>



WIFI	2.4GHz 2400~2483.5MHz Band Edge @ 3m	
ANT	802.11n HT20 CH06 2437MHz - R	
1+2	Vertical	Fundamental
Peak	<p>Site : 03CH13-HY Condition : PEAK_BE_74 3m HORN 9120D 1522 VERTICAL</p>	Left Blank
Avg.	<p>Site : 03CH13-HY Condition : AVG_BE_54 3m HORN 9120D 1522 VERTICAL</p>	Left Blank

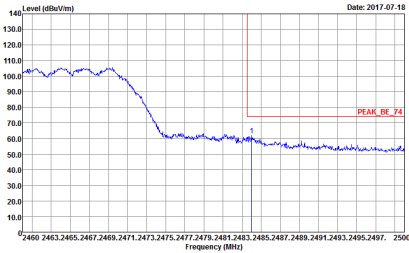
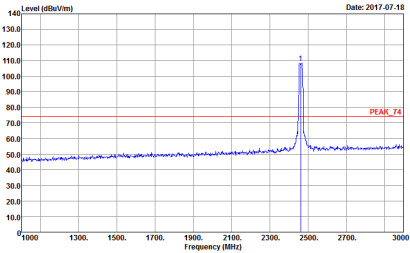
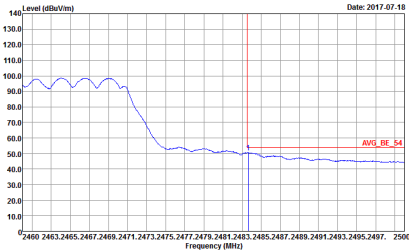
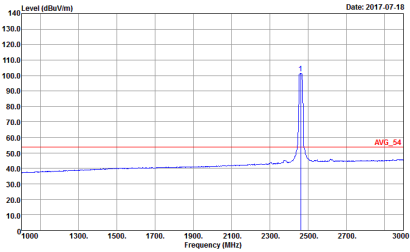

WIFI	2.4GHz 2400~2483.5MHz Band Edge @ 3m	
ANT	802.11n HT20 CH11 2462MHz	
1+2	Horizontal	Fundamental
Peak	 <p>Level (dBuV/m) vs Frequency (MHz) plot for Horizontal. The y-axis ranges from 10.0 to 140.0 dBuV/m, and the x-axis ranges from 2460 to 2500 MHz. A red vertical line marks a peak at approximately 2462 MHz, labeled 'PEAK_BE_74'. The signal level is around 60-70 dBuV/m at this frequency.</p> <p>Site : 03CH13-HY Condition : PEAK_BE_74 3m HORN 9120D 1522 HORIZONTAL</p>	 <p>Level (dBuV/m) vs Frequency (MHz) plot for Fundamental. The y-axis ranges from 10.0 to 140.0 dBuV/m, and the x-axis ranges from 1000 to 3000 MHz. A sharp red peak is visible at approximately 2462 MHz, labeled 'PEAK_74'. The signal level is approximately 110 dBuV/m.</p> <p>Site : 03CH13-HY Condition : PEAK_74 3m HORN 9120D 1522 HORIZONTAL</p>
Avg.	 <p>Level (dBuV/m) vs Frequency (MHz) plot for Horizontal (Average). The y-axis ranges from 10.0 to 140.0 dBuV/m, and the x-axis ranges from 2460 to 2500 MHz. A red vertical line marks a peak at approximately 2462 MHz, labeled 'AVG_BE_54'. The signal level is around 50-60 dBuV/m.</p> <p>Site : 03CH13-HY Condition : AVG_BE_54 3m HORN 9120D 1522 HORIZONTAL</p>	 <p>Level (dBuV/m) vs Frequency (MHz) plot for Fundamental (Average). The y-axis ranges from 10.0 to 140.0 dBuV/m, and the x-axis ranges from 1000 to 3000 MHz. A sharp red peak is visible at approximately 2462 MHz, labeled 'AVG_54'. The signal level is approximately 100 dBuV/m.</p> <p>Site : 03CH13-HY Condition : AVG_54 3m HORN 9120D 1522 HORIZONTAL</p>

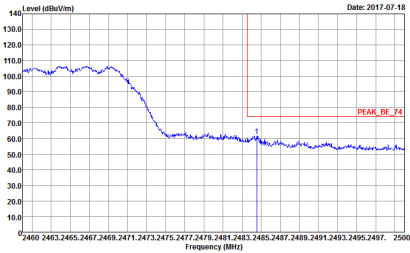
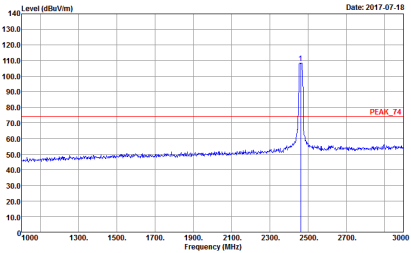
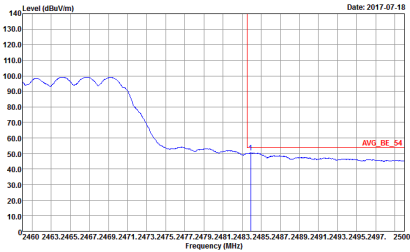
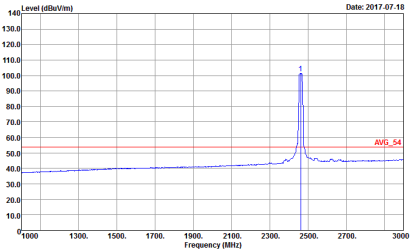

WIFI	2.4GHz 2400~2483.5MHz Fundamental @ 3m	
ANT	802.11n HT20 CH11 2462MHz	
1+2	Vertical	Fundamental
Peak	 <p>Date: 2017-07-18</p> <p>Site : 03CH13-HY Condition : PEAK_BE_74 3m HORN 9120D 1522 VERTICAL</p>	 <p>Date: 2017-07-18</p> <p>Site : 03CH13-HY Condition : PEAK_74 3m HORN 9120D 1522 VERTICAL</p>
Avg.	 <p>Date: 2017-07-18</p> <p>Site : 03CH13-HY Condition : AVG_BE_54 3m HORN 9120D 1522 VERTICAL</p>	 <p>Date: 2017-07-18</p> <p>Site : 03CH13-HY Condition : AVG_54 3m HORN 9120D 1522 VERTICAL</p>

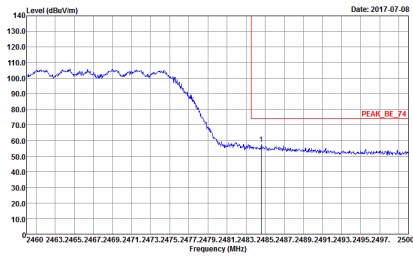
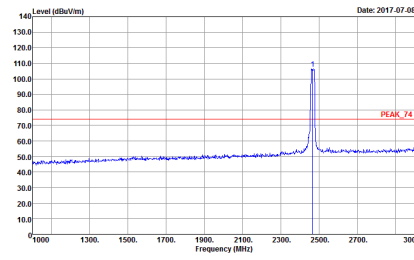
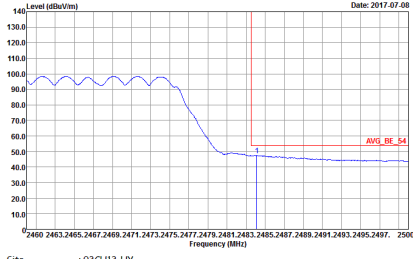
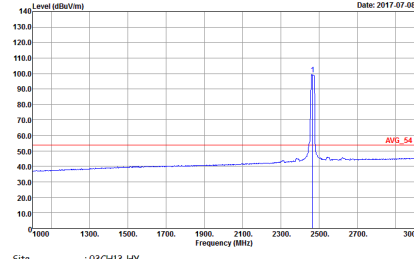

WIFI	2.4GHz 2400~2483.5MHz Band Edge @ 3m	
ANT	802.11n HT20 CH12 2467MHz	
1+2	Horizontal	Fundamental
Peak	 <p>Date: 2017-07-08</p> <p>Site : 03CH13-HY Condition : PEAK BE 74 3m HORN 9120D 1522 HORIZONTAL</p>	 <p>Date: 2017-07-08</p> <p>Site : 03CH13-HY Condition : PEAK 74 3m HORN 9120D 1522 HORIZONTAL</p>
Avg.	 <p>Date: 2017-07-08</p> <p>Site : 03CH13-HY Condition : AV6 BE 54 3m HORN 9120D 1522 HORIZONTAL</p>	 <p>Date: 2017-07-08</p> <p>Site : 03CH13-HY Condition : AV6 54 3m HORN 9120D 1522 HORIZONTAL</p>

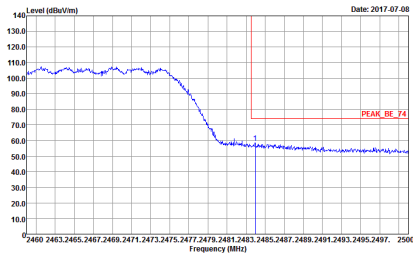
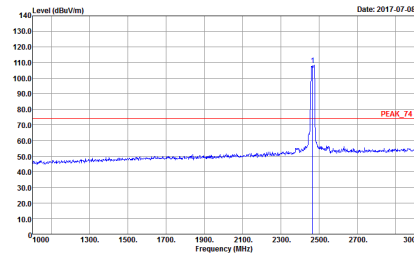
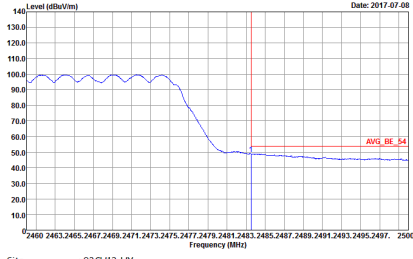
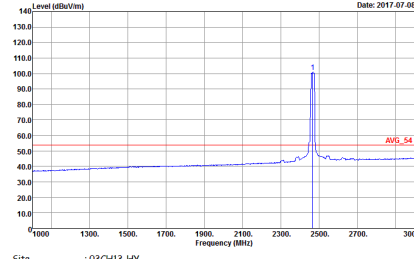

WIFI	2.4GHz 2400~2483.5MHz Fundamental @ 3m	
ANT	802.11n HT20 CH12 2467MHz	
1+2	Vertical	Fundamental
Peak	 <p>Date: 2017-07-08</p> <p>Site : 03CH13-HY Condition : PEAK_BE_74 3m HORN 9120D 1522 VERTICAL</p>	 <p>Date: 2017-07-08</p> <p>Site : 03CH13-HY Condition : PEAK_74 3m HORN 9120D 1522 VERTICAL</p>
Avg.	 <p>Date: 2017-07-08</p> <p>Site : 03CH13-HY Condition : AVG_BE_54 3m HORN 9120D 1522 VERTICAL</p>	 <p>Date: 2017-07-08</p> <p>Site : 03CH13-HY Condition : AVG_54 3m HORN 9120D 1522 VERTICAL</p>

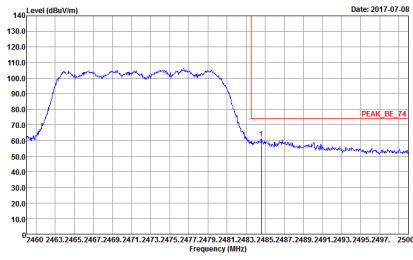
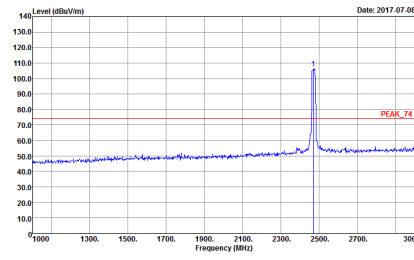
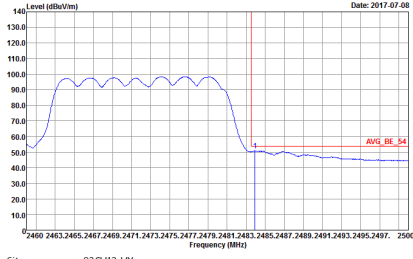
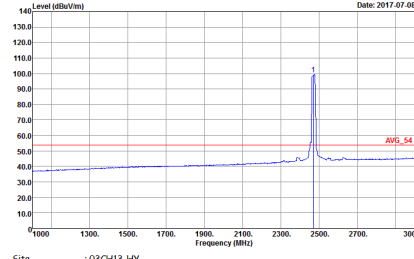

WIFI	2.4GHz 2400~2483.5MHz Band Edge @ 3m	
ANT	802.11n HT20 CH13 2472MHz	
1+2	Horizontal	Fundamental
Peak	 <p>Date: 2017-07-08</p> <p>Site : 03CH13-HY Condition : PEAK_BE_74 3m HORN 9120D 1522 HORIZONTAL</p>	 <p>Date: 2017-07-08</p> <p>Site : 03CH13-HY Condition : PEAK_74 3m HORN 9120D 1522 HORIZONTAL</p>
Avg.	 <p>Date: 2017-07-08</p> <p>Site : 03CH13-HY Condition : AVG_BE_54 3m HORN 9120D 1522 HORIZONTAL</p>	 <p>Date: 2017-07-08</p> <p>Site : 03CH13-HY Condition : AVG_54 3m HORN 9120D 1522 HORIZONTAL</p>



WIFI	2.4GHz 2400~2483.5MHz Fundamental @ 3m	
ANT	802.11n HT20 CH13 2472MHz	
1+2	Vertical	Fundamental
Peak	<p>Site : 03CH13-HY Condition : PEAK BE 74 3m HORN 9120D 1522 VERTICAL</p>	<p>Site : 03CH13-HY Condition : PEAK 74 3m HORN 9120D 1522 VERTICAL</p>
Avg.	<p>Site : 03CH13-HY Condition : AV6 BE 54 3m HORN 9120D 1522 VERTICAL</p>	<p>Site : 03CH13-HY Condition : AV6 54 3m HORN 9120D 1522 VERTICAL</p>



2.4GHz 2400~2483.5MHz
WIFI 802.11g (Harmonic @ 3m)

WIFI	2.4GHz 2400~2483.5MHz Harmonic @ 3m	
ANT	802.11g CH01 2412MHz	
1+2	Horizontal	Vertical
Peak Avg.	<p>Site : 03CH13-#Y Condition : PEAK_74 3m SHF_HORN_584 HORIZONTAL Detector : Peak Project : 742534-01 Mode : 18</p>	<p>Site : 03CH13-#Y Condition : PEAK_74 3m SHF_HORN_584 VERTICAL Detector : Peak Project : 742534-01 Mode : 18</p>



WIFI	2.4GHz 2400~2483.5MHz Harmonic @ 3m	
ANT	802.11g CH06 2437MHz	
1+2	Horizontal	Vertical
Peak Avg.	<p>Site : 03CH13-HY Condition : PEAK 74 3m SHF HORN 584 HORIZONTAL</p>	<p>Site : 03CH13-HY Condition : PEAK 74 3m SHF HORN 584 VERTICAL</p>

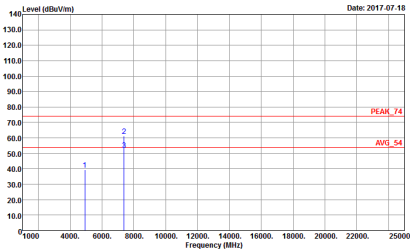
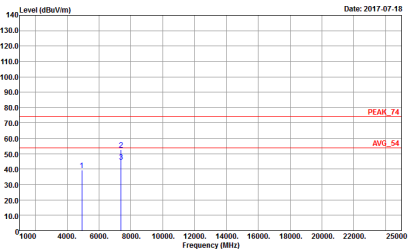

WIFI	2.4GHz 2400~2483.5MHz Harmonic @ 3m	
ANT	802.11g CH11 2462MHz	
1+2	Horizontal	Vertical
<p>Peak</p> <p>Avg.</p>	 <p>Site : 03CH13-HY Condition : PEAK 74 3m SHF HORN 584 HORIZONTAL</p>	 <p>Site : 03CH13-HY Condition : PEAK 74 3m SHF HORN 584 VERTICAL</p>



WIFI	2.4GHz 2400~2483.5MHz Harmonic @ 3m	
ANT	802.11g CH12 2467MHz	
1+2	Horizontal	Vertical
Peak Avg.	<p>Site : 03CH13-HY Condition : PEAK 74 3m SHF HORN 584 HORIZONTAL</p>	<p>Site : 03CH13-HY Condition : PEAK 74 3m SHF HORN 584 VERTICAL</p>

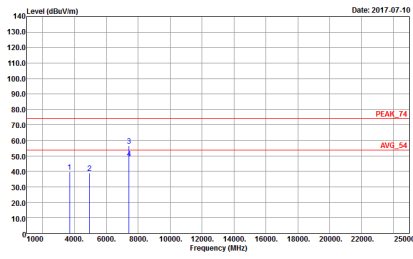
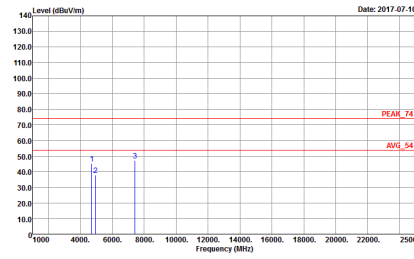

WIFI	2.4GHz 2400~2483.5MHz Harmonic @ 3m	
ANT	802.11g CH13 2472MHz	
1+2	Horizontal	Vertical
<p>Peak</p> <p>Avg.</p>	 <p>Site : 03CH13-HY Condition : PEAK 74 3m SHF HORN 584 HORIZONTAL</p>	 <p>Site : 03CH13-HY Condition : PEAK 74 3m SHF HORN 584 VERTICAL</p>



2.4GHz 2400~2483.5MHz

WIFI 802.11n HT20 (Harmonic @ 3m)

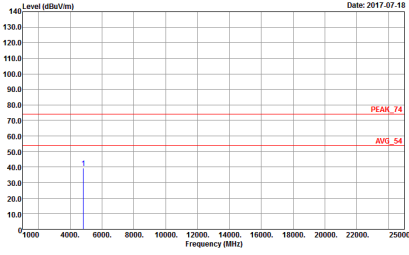
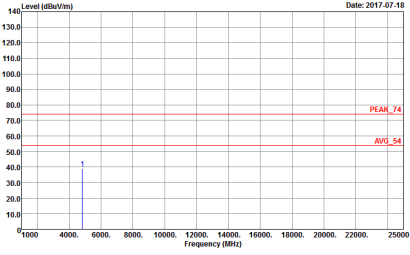
WIFI	2.4GHz 2400~2483.5MHz Harmonic @ 3m	
ANT	802.11n HT20 CH01 2412MHz	
1+2	Horizontal	Vertical
<p>Peak</p> <p>Avg.</p>	 <p>Site : 03CH13-HY Condition : PEAK 74 3m SHF HORN 584 HORIZONTAL</p>	 <p>Site : 03CH13-HY Condition : PEAK 74 3m SHF HORN 584 VERTICAL</p>

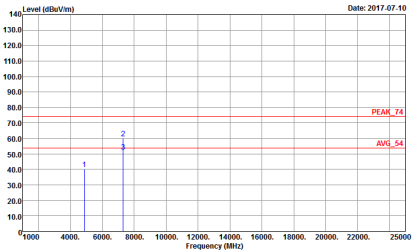
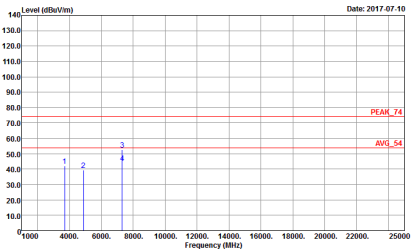

WIFI	2.4GHz 2400~2483.5MHz Harmonic @ 3m	
ANT	802.11n HT20 CH06 2437MHz	
1+2	Horizontal	Vertical
<p>Peak</p> <p>Avg.</p>	 <p>Date: 2017-07-10</p> <p>Site : 03CH13-HY Condition : PEAK 74 3m SHF HORN 584 HORIZONTAL</p>	 <p>Date: 2017-07-10</p> <p>Site : 03CH13-HY Condition : PEAK 74 3m SHF HORN 584 VERTICAL</p>

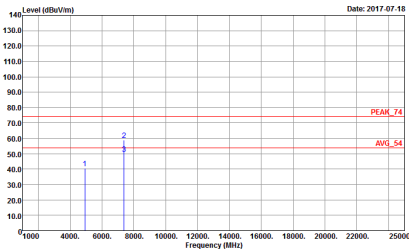
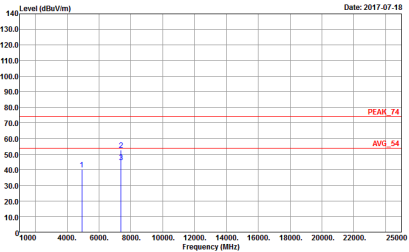

WIFI	2.4GHz 2400~2483.5MHz Harmonic @ 3m	
ANT	802.11n HT20 CH11 2462MHz	
1+2	Horizontal	Vertical
<p>Peak</p> <p>Avg.</p>	 <p>Site : 03CH13-HY Condition : PEAK 74 3m SHF HORN 584 HORIZONTAL</p>	 <p>Site : 03CH13-HY Condition : PEAK 74 3m SHF HORN 584 VERTICAL</p>



WIFI	2.4GHz 2400~2483.5MHz Harmonic @ 3m	
ANT	802.11n HT20 CH12 2467MHz	
1+2	Horizontal	Vertical
<p>Peak</p> <p>Avg.</p>	<p>Site : 03CH13-HY Condition : PEAK 74 3m SHF HORN 584 HORIZONTAL</p>	<p>Site : 03CH13-HY Condition : PEAK 74 3m SHF HORN 584 VERTICAL</p>



WIFI	2.4GHz 2400~2483.5MHz Harmonic @ 3m	
ANT	802.11n HT20 CH13 2472MHz	
1+2	Horizontal	Vertical
Peak Avg.	<p>Horizontal graph showing Level (dBuV/m) vs Frequency (MHz). The y-axis ranges from 0 to 140 dBuV/m, and the x-axis ranges from 0 to 25000 MHz. Two peaks are visible at approximately 5.5 MHz and 7.5 MHz. The peak at 7.5 MHz is labeled PEAK_74 and the peak at 5.5 MHz is labeled AVG_54. The date is 2017-07-10. Site: 03CH13-HY, Condition: PEAK_74 3m SHF HORN 584 HORIZONTAL.</p>	<p>Vertical graph showing Level (dBuV/m) vs Frequency (MHz). The y-axis ranges from 0 to 140 dBuV/m, and the x-axis ranges from 0 to 25000 MHz. Two peaks are visible at approximately 5.5 MHz and 7.5 MHz. The peak at 7.5 MHz is labeled PEAK_74 and the peak at 5.5 MHz is labeled AVG_54. The date is 2017-07-10. Site: 03CH13-HY, Condition: PEAK_74 3m SHF HORN 584 VERTICAL.</p>



Emission below 1GHz
2.4GHz WIFI 802.11g (LF)

WIFI	2.4GHz 2400~2483.5MHz	
ANT	802.11g LF	
1+2	Horizontal	Vertical
QP / Peak	<p>Site : 03CH13-14Y Condition : QP 3m 81LOG 40103 HORIZONTAL</p>	<p>Site : 03CH13-14Y Condition : QP 3m 81LOG 40103 VERTICAL</p>



Appendix E. Duty Cycle Plots

Antenna	Band	Duty Cycle(%)	T(us)	1/T(kHz)	VBW Setting
1	802.11b	98.62	-	-	10Hz
2	802.11b	98.62	-	-	10Hz
1 + 2	802.11g for Ant. 1	92.21	1420	0.70	1kHz
1 + 2	802.11g for Ant. 2	93.42	1420	0.70	1kHz
1 + 2	2.4GHz 802.11n HT20 for Ant. 1	91.67	1320	0.76	1kHz
1 + 2	2.4GHz 802.11n HT20 for Ant. 2	91.67	1320	0.76	1kHz



<Ant. 1>

802.11b

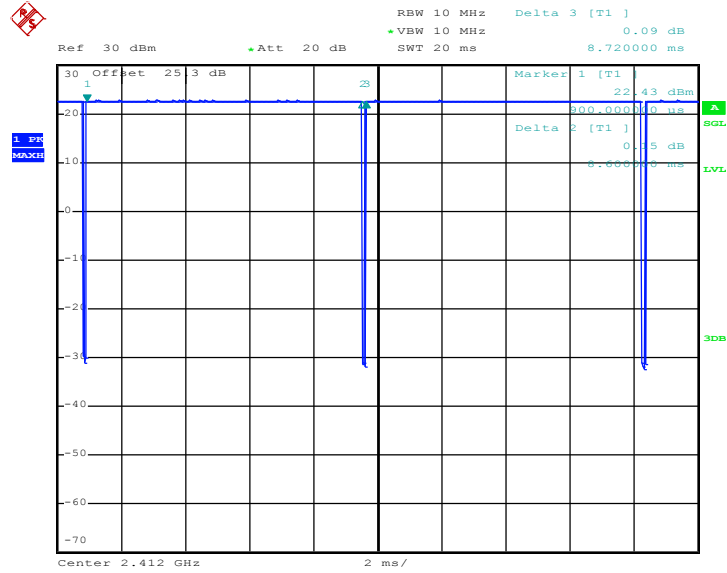

Date: 5.JUL.2017 21:33:37

<Ant. 2>

802.11b

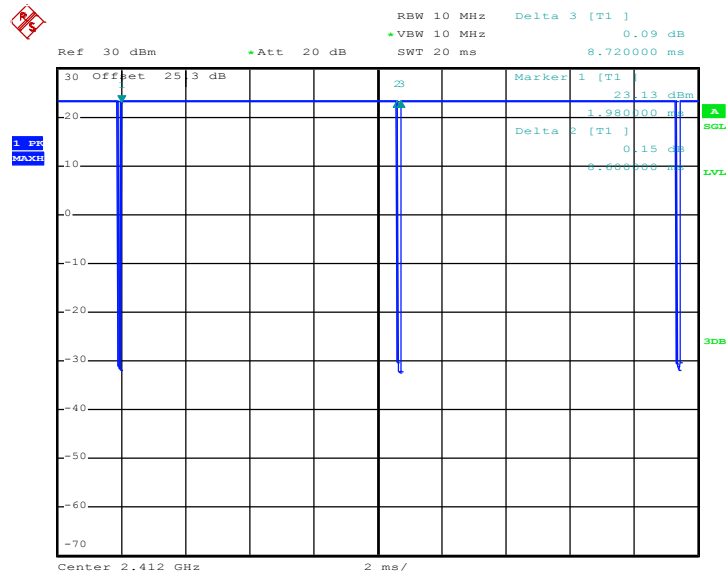

Date: 5.JUL.2017 21:35:48



MIMO <Ant. 1>

802.11g

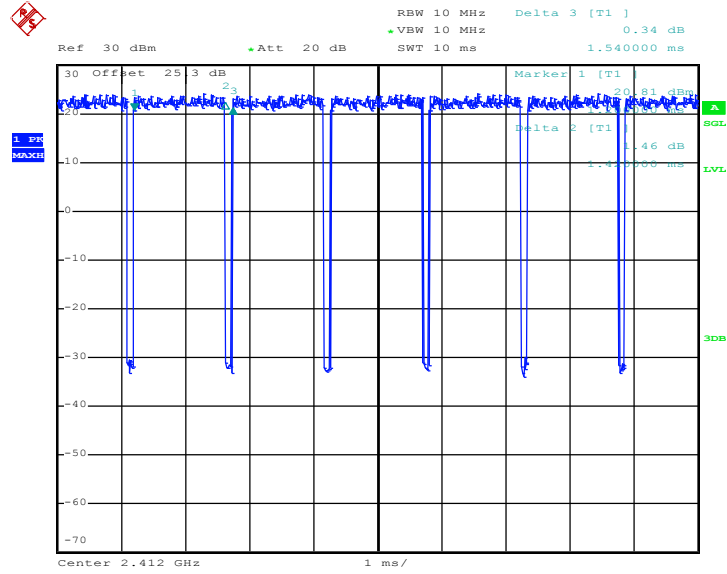

Date: 5.JUL.2017 22:18:12

802.11n HT20

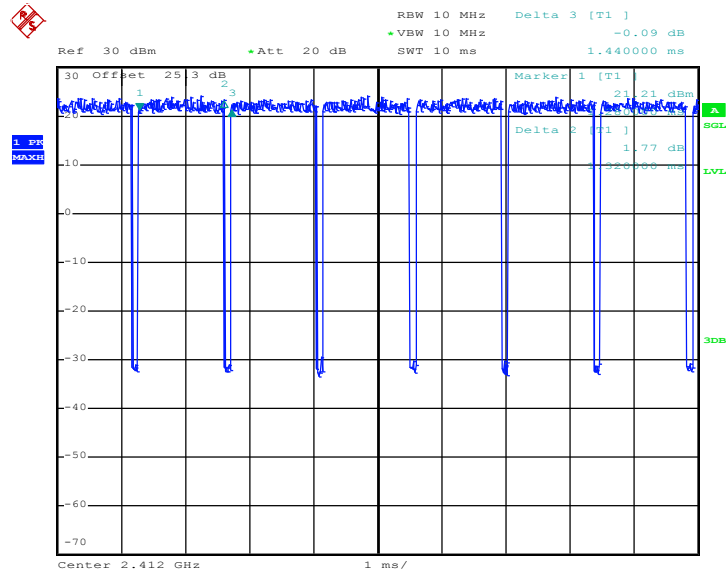

Date: 5.JUL.2017 22:25:33



MIMO <Ant. 2>

802.11g

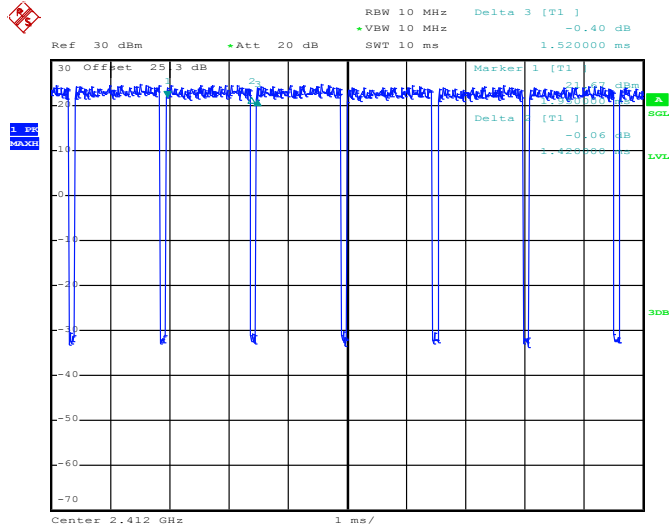

Date: 5.JUL.2017 22:18:47

802.11n HT20

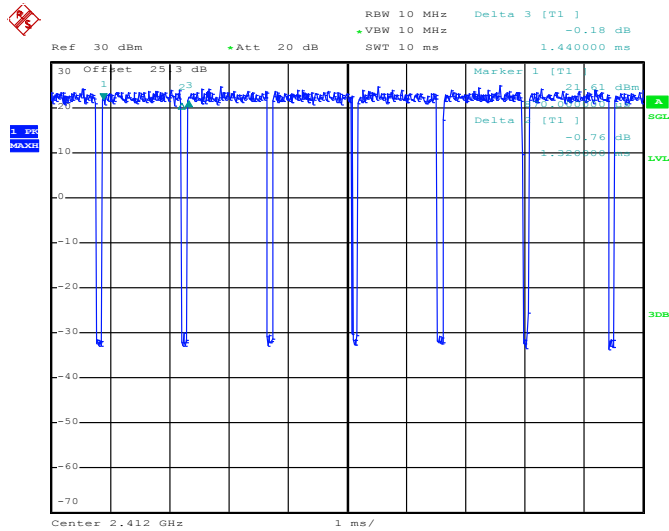

Date: 5.JUL.2017 22:26:07