

FCC Test Report

Product Name	Blood Glucose Monitoring System
Model No.	Tyson Bio HS100-B
FCC ID.	2AJZ6HS100B

Applicant	Tyson Bioresearch, Inc.
Address	5F., No. 16, 18, 20, 22, Kedong 3rd Rd., Zhunan Township, Miaoli County 35053, Taiwan

Date of Receipt	Mar. 27, 2018
Issued Date	May 25, 2018
Report No.	1830403R-RFUSP01V00
Report Version	V1.0



The test results relate only to the samples tested.

The test results shown in the test report are traceable to the national/international standard through the calibration report of the equipment and evaluated measurement uncertainty herein.

This report must not be used to claim product endorsement by TAF or any agency of the government.

The test report shall not be reproduced without the written approval of DEKRA Testing and Certification Co., Ltd.

Test Report

Issued Date: May 25, 2018

Report No.: 1830403R-RFUSP01V00



Product Name	Blood Glucose Monitoring System
Applicant	Tyson Bioresearch, Inc.
Address	5F., No. 16, 18, 20, 22, Kedong 3rd Rd., Zhunan Township, Miaoli County 35053, Taiwan
Manufacturer	Tyson Bioresearch, Inc.
Model No.	Tyson Bio HS100-B
FCC ID.	2AJZ6HS100B
EUT Rated Voltage	DC 3V (Power By Battery)
EUT Test Voltage	DC 3V (Power By Battery)
Trade Name	Tyson Bio
Applicable Standard	FCC CFR Title 47 Part 15 Subpart C: 2017 ANSI C63.4: 2014, ANSI C63.10: 2013 KDB 558074 D01 DTS Meas Guidance v04
Test Result	Complied

Documented By :



(Senior Adm. Specialist / Joanne Lin)

Tested By :

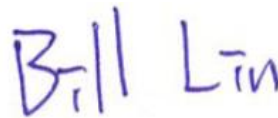

(Engineer / Bill Lin)

Approved By :



(Director / Vincent Lin)

TABLE OF CONTENTS

Description	Page
1. GENERAL INFORMATION	4
1.1. EUT Description.....	4
1.2. Operational Description.....	6
1.3. Tested System Details.....	7
1.4. Configuration of Tested System	7
1.5. EUT Exercise Software	7
1.6. Test Facility	8
1.7. List of Test Equipment.....	9
2. CONDUCTED EMISSION	10
2.1. Test Setup	10
2.2. Limits.....	10
2.3. Test Procedure	11
2.4. Uncertainty	11
2.5. Test Result of Conducted Emission.....	12
3. PEAK POWER OUTPUT	13
3.1. Test Setup	13
3.2. Limit	13
3.3. Test Procedure	13
3.4. Uncertainty	13
3.5. Test Result of Peak Power Output	14
4. RADIATED EMISSION	14
4.1. Test Setup	15
4.2. Limits.....	16
4.3. Test Procedure	17
4.4. Uncertainty	18
4.5. Test Result of Radiated Emission.....	19
5. RF ANTENNA CONDUCTED TEST	27
5.1. Test Setup	27
5.2. Limits.....	27
5.3. Test Procedure	27
5.4. Uncertainty	27
5.5. Test Result of RF Antenna Conducted Test	28
6. BAND EDGE	29
6.1. Test Setup	29
6.2. Limit	30
6.3. Test Procedure	30
6.4. Uncertainty	31
6.5. Test Result of Band Edge	32
7. 6DB BANDWIDTH	36
7.1. Test Setup	36
7.2. Limits.....	36
7.3. Test Procedure	36
7.4. Uncertainty	36
7.5. Test Result of 6dB Bandwidth.....	37
8. POWER DENSITY	39
8.1. Test Setup	39
8.2. Limits.....	39
8.3. Test Procedure	39
8.4. Uncertainty	39
8.5. Test Result of Power Density	40
9. DUTY CYCLE	42
9.1. Test Setup	42
9.2. Test Procedure	42
9.3. Uncertainty	42
9.4. Test Result of Duty Cycle.....	43
10. EMI REDUCTION METHOD DURING COMPLIANCE TESTING	44
Attachment 1: EUT Test Photographs	
Attachment 2: EUT Detailed Photographs	

1. GENERAL INFORMATION

1.1. EUT Description

Product Name	Blood Glucose Monitoring System
Trade Name	Tyson Bio
Model No.	Tyson Bio HS100-B
FCC ID.	2AJZ6HS100B
Frequency Range	2402-2480MHz
Channel Number	V4.0: 40CH
Type of Modulation	V4.0: GFSK(1Mbps)
Antenna Type	PIFA Antenna
Channel Control	Auto
Antenna Gain	Refer to the table "Antenna List"

Antenna List

No.	Manufacturer	Part No.	Antenna Type	Peak Gain
1	Tyson Bioresearch, Inc.	N/A	PIFA Antenna	5.3dBi for 2.4 GHz

Note: The antenna of EUT is conforming to FCC 15.203.

Center Frequency of Each Channel: (For V4.0)

Channel	Frequency	Channel	Frequency	Channel	Frequency	Channel	Frequency
Channel 00:	2402 MHz	Channel 01:	2404 MHz	Channel 02:	2406 MHz	Channel 03:	2408 MHz
Channel 04:	2410 MHz	Channel 05:	2412 MHz	Channel 06:	2414 MHz	Channel 07:	2416 MHz
Channel 08:	2418 MHz	Channel 09:	2420 MHz	Channel 10:	2422 MHz	Channel 11:	2424 MHz
Channel 12:	2426 MHz	Channel 13:	2428 MHz	Channel 14:	2430 MHz	Channel 15:	2432 MHz
Channel 16:	2434 MHz	Channel 17:	2436 MHz	Channel 18:	2438 MHz	Channel 19:	2440 MHz
Channel 20:	2442 MHz	Channel 21:	2444 MHz	Channel 22:	2446 MHz	Channel 23:	2448 MHz
Channel 24:	2450 MHz	Channel 25:	2452 MHz	Channel 26:	2454 MHz	Channel 27:	2456 MHz
Channel 28:	2458 MHz	Channel 29:	2460 MHz	Channel 30:	2462 MHz	Channel 31:	2464 MHz
Channel 32:	2466 MHz	Channel 33:	2468 MHz	Channel 34:	2470 MHz	Channel 35:	2472 MHz
Channel 36:	2474 MHz	Channel 37:	2476 MHz	Channel 38:	2478 MHz	Channel 39:	2480 MHz

Note:

1. The EUT is a Blood Glucose Monitoring System with a built-in Bluetooth V4.0.
2. These tests were conducted on a sample for the purpose of demonstrating compliance of Bluetooth transmitter with Part 15 Subpart C Paragraph 15.247 for spread spectrum devices.
3. Regarding to the operation frequency, the lowest, middle and highest frequency are selected to perform the test.
4. The radiation measurements are performed in X, Y, Z axis positioning. Only the worst case is shown in the report.

Test Mode	Mode 1: Transmit - BLE
-----------	------------------------

1.3. Tested System Details

The types for all equipment, plus descriptions of all cables used in the tested system (including inserted cards) are:

Product	Manufacturer	Model No.	Serial No.	Power Cord
1 Notebook PC	DELL	P62G	CY9FJC2	N/A
2 Test fixture	TEXAS INSTRUMENTS	N/A	N/A	N/A

Signal Cable Type	Signal cable Description
A Signal Cable	Non-Shielded, 0.2m
B USB Cable	Shielded, 1.5m

1.4. Configuration of Tested System

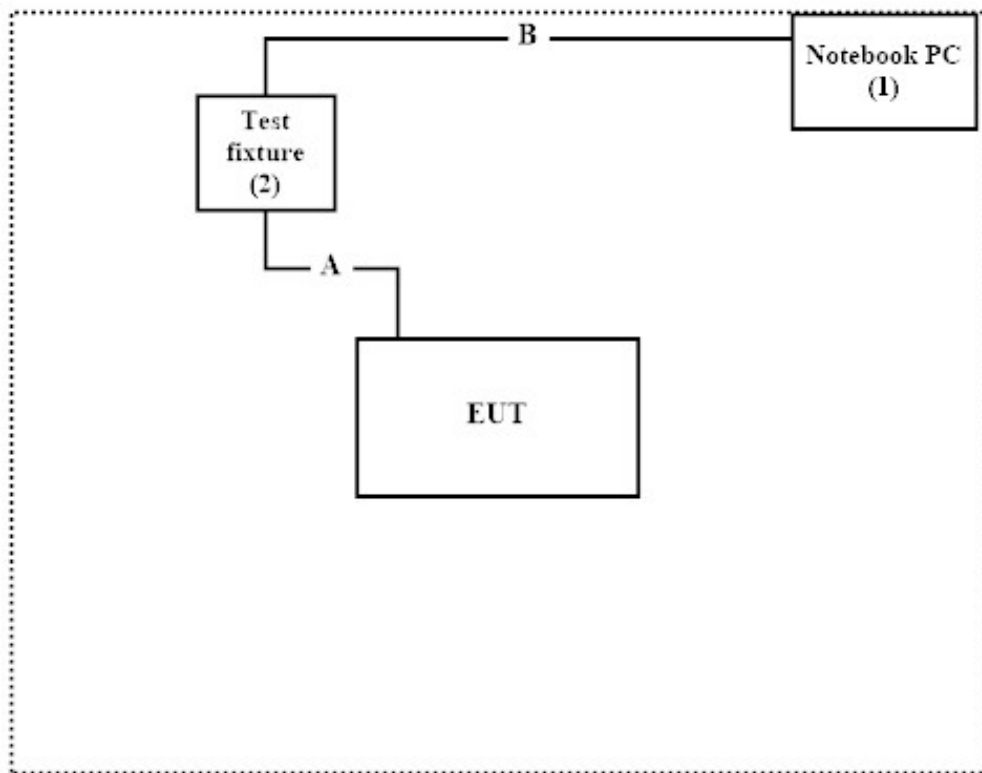

1.5. EUT Exercise Software

1. Setup the EUT as shown in Section 1.4.
2. Execute software “SmartRF Studio 7 2.2.1” on the Notebook PC.
3. Configure the test mode, the test channel, and the data rate.
4. Press “OK” to start the continuous Transmit.
5. Verify that the EUT works properly.

1.6. Test Facility

Ambient conditions in the laboratory:

Items	Required (IEC 68-1)	Actual
Temperature (°C)	15-35	20-35
Humidity (%RH)	25-75	50-65
Barometric pressure (mbar)	860-1060	950-1000

The related certificate for our laboratories about the test site and management system can be downloaded from DEKRA Testing and Certification Co., Ltd. Web Site:

<http://www.dekra.com.tw/english/about/certificates.aspx?bval=5>

The address and introduction of DEKRA Testing and Certification Co., Ltd. laboratories can be founded in our Web site: http://www.dekra.com.tw/index_en

Site Description: Accredited by TAF
Accredited Number: 3023

Site Name: DEKRA Testing and Certification Co., Ltd.
Site Address: No.159, Sec. 2, Wenhua 1st Rd., Linkou Dist.,
New Taipei City 24457, Taiwan.
TEL: 886-2-2602-7968 / FAX : 866-2-2602-3286
E-Mail : info.tw@dekra.com

FCC Accreditation Number: TW3023

1.7. List of Test Equipment

For Conduction measurements /ASR1

	Equipment	Manufacturer	Model No.	Serial No.	Cali. Data	Due. Data
X	EMI Test Receiver	R&S	ESR7	101601	2018.02.08	2019.02.07
X	Two-Line V-Network	R&S	ENV216	101306	2018.03.09	2019.03.08
X	Two-Line V-Network	R&S	ENV216	101307	2018.03.20	2019.03.19
X	Coaxial Cable	Quietek	RG400_BNC	RF001	2018.05.24	2019.05.23

Note:

1. All equipments are calibrated every one year.
2. The test instruments marked with "X" are used to measure the final test results.
3. Test Software version : QuieTek EMI 2.0 V2.1.113

For Conducted measurements /ASR4

	Equipment	Manufacturer	Model No.	Serial No.	Cali. Data	Due. Data
X	Spectrum Analyzer	R&S	FSV30	103464	2018.01.23	2019.01.22
X	Power Meter	Anritsu	ML2496A	1548003	2017.12.11	2018.12.10
X	Power Sensor	Anritsu	MA2411B	1531024	2017.12.11	2018.12.10
X	Power Sensor	Anritsu	MA2411B	1531025	2017.12.11	2018.12.10
	Bluetooth Tester	R&S	CBT	101238	2018.01.18	2019.01.17

Note:

1. All equipments are calibrated every one year.
2. The test instruments marked with "X" are used to measure the final test results.
3. Test Software version : QuieTek Conduction Test System V8.0.110

For Radiated measurements /ACB1

	Equipment	Manufacturer	Model No.	Serial No.	Cali. Data	Due. Data
X	Loop Antenna	AMETEK	HLA6121	49611	2018.01.26	2019.01.25
X	Bi-Log Antenna	SCHWARZBECK	VULB9168	9168-674	2018.04.02	2019.04.01
X	Horn Antenna	ETS-Lindgren	3117	00203800	2017.11.10	2018.11.09
X	Horn Antenna	Com-Power	AH-840	101087	2017.05.24	2018.05.23
X	Pre-Amplifier	EMCI	EMC001330	980301	2018.05.17	2019.05.16
X	Pre-Amplifier	EMCI	EMC051835SE	980312	2018.05.16	2019.05.15
X	Pre-Amplifier	EMCI	EMC05820SE	980308	2017.06.13	2018.06.12
X	Pre-Amplifier	EMCI	EMC184045SE	980314	2018.05.16	2019.05.15
X	Filter	MICRO TRONICS	BRM50702	G251	2017.08.30	2018.08.29
	Filter	MICRO TRONICS	BRM50716	G188	2017.08.30	2018.08.29
X	EMI Test Receiver	R&S	ESR7	101602	2017.12.11	2018.12.10
X	Spectrum Analyzer	R&S	FSV40	101148	2018.02.08	2019.02.07
X	Coaxial Cable	SUHNER	SUCOFLEX 106	RF002	2017.05.25	2018.05.24
X	Mircoflex Cable	HUBER SUHNER	SUCOFLEX 102	MY3381/2	2017.08.11	2018.08.10

Note:

1. Loop Antenna is calibrated every two year, the other equipments are calibrated every one year.
2. The test instruments marked with "X" are used to measure the final test results.
3. Test Software version : QuieTek EMI 2.0 V2.1.113

2. Conducted Emission

2.1. Test Setup

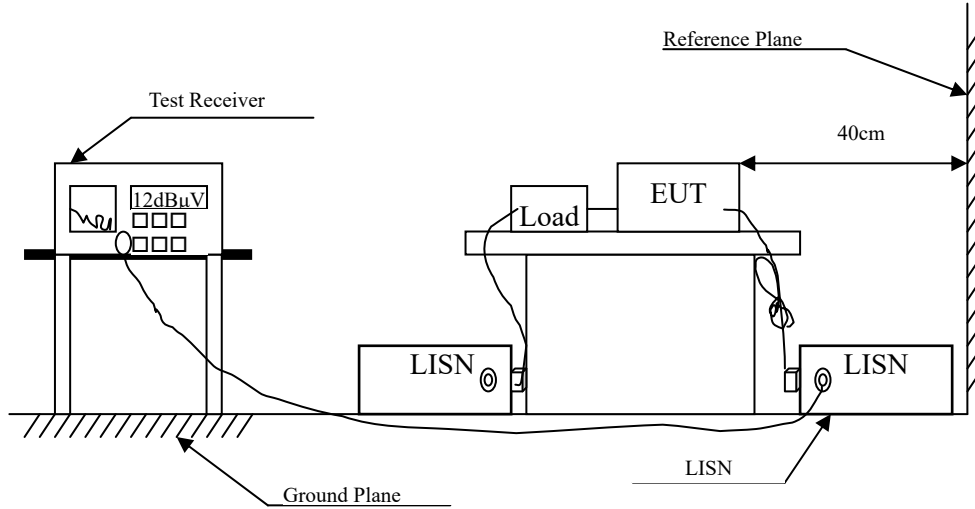

2.2. Limits

FCC Part 15 Subpart C Paragraph 15.207 (dB μ V) Limit		
Frequency MHz	Limits	
	QP	AV
0.15 - 0.50	66-56	56-46
0.50-5.0	56	46
5.0 - 30	60	50

Remarks: In the above table, the tighter limit applies at the band edges.

2.3. Test Procedure

The EUT and Peripherals are connected to the main power through a line impedance stabilization network (L.I.S.N.). This provides a 50 ohm /50uH coupling impedance for the measuring equipment. The peripheral devices are also connected to the main power through a LISN that provides a 50ohm /50uH coupling impedance with 50ohm termination. (Please refer to the block diagram of the test setup and photographs.)

Both sides of A.C. line are checked for maximum conducted interference. In order to find the maximum emission, the relative positions of equipment and all the interface cables must be changed according to ANSI C63.4: 2014 on conducted measurement.

Conducted emissions were investigated over the frequency range from 0.15MHz to 30MHz using a receiver bandwidth of 9kHz.

The EUT was setup to ANSI C63.4, 2014; tested to DTS test procedure of FCC KDB-558074 for compliance to FCC 47CFR Subpart C requirements.

2.4. Uncertainty

±2.35dB

2.5. Test Result of Conducted Emission

Owing to the DC operation of EUT, this test item is not performed.

3. Peak Power Output

3.1. Test Setup

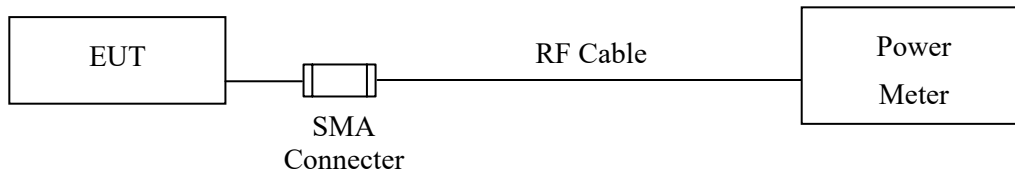

3.2. Limit

The maximum peak power shall be less 1Watt.

3.3. Test Procedure

Tested according to DTS test procedure of KDB 558074 for compliance to FCC 47CFR 15.247 requirements. The maximum peak conducted output power using KDB 558074 section 9.1.2 PKPM1 Peak power meter method.

3.4. Uncertainty

± 0.86 dB

3.5. Test Result of Peak Power Output

Product : Blood Glucose Monitoring System
Test Item : Peak Power Output
Test Mode : Mode 1: Transmit - BLE
Test Date : 2018/05/18

Channel No.	Frequency (MHz)	Measurement (dBm)	Required Limit	Result
Channel 00	2402.00	-1.77	1 Watt= 30 dBm	Pass
Channel 19	2440.00	-2.27	1 Watt= 30 dBm	Pass
Channel 39	2480.00	-2.77	1 Watt= 30 dBm	Pass

4. Radiated Emission

4.1. Test Setup

Radiated Emission Under 30MHz

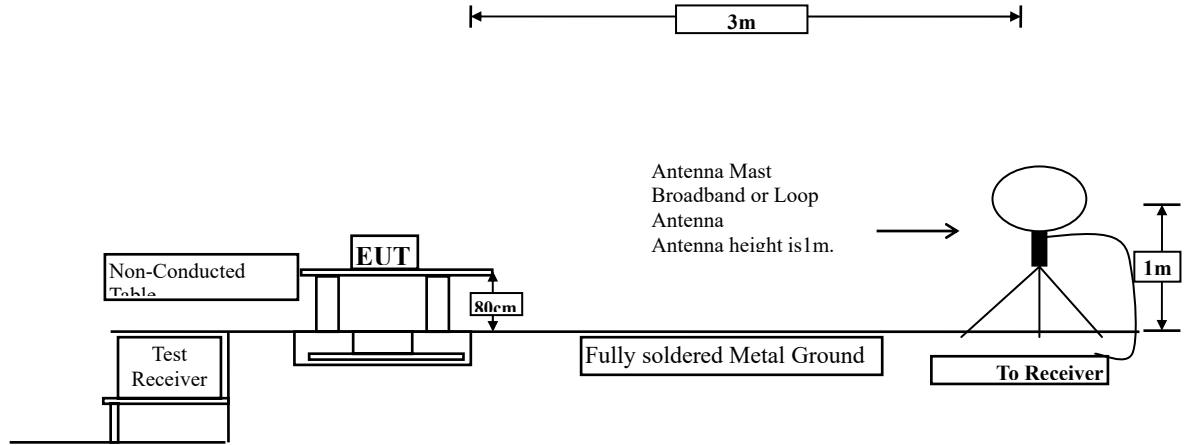

Radiated Emission Below 1GHz

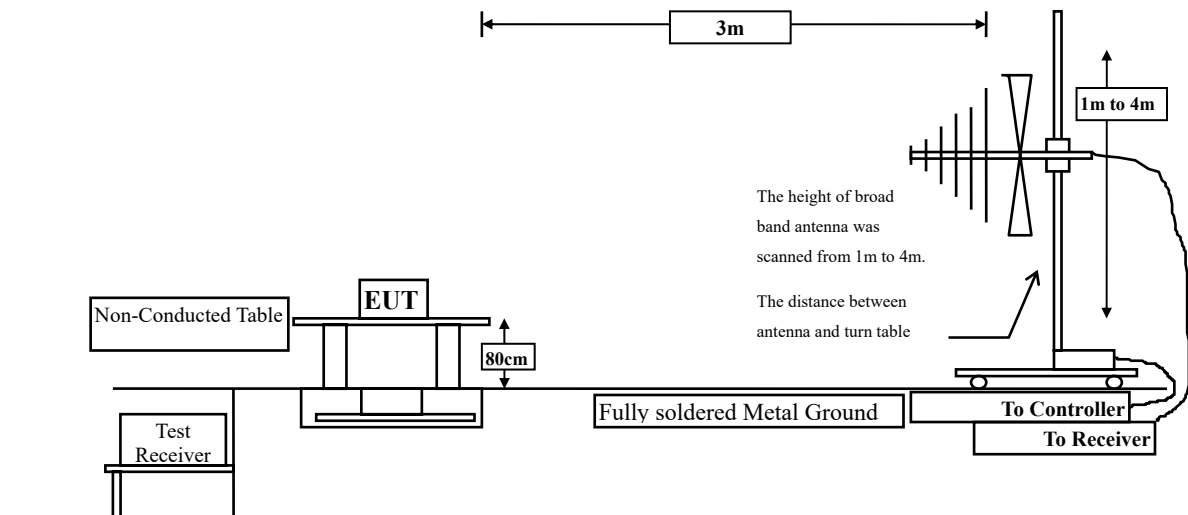

Radiated Emission Above 1GHz

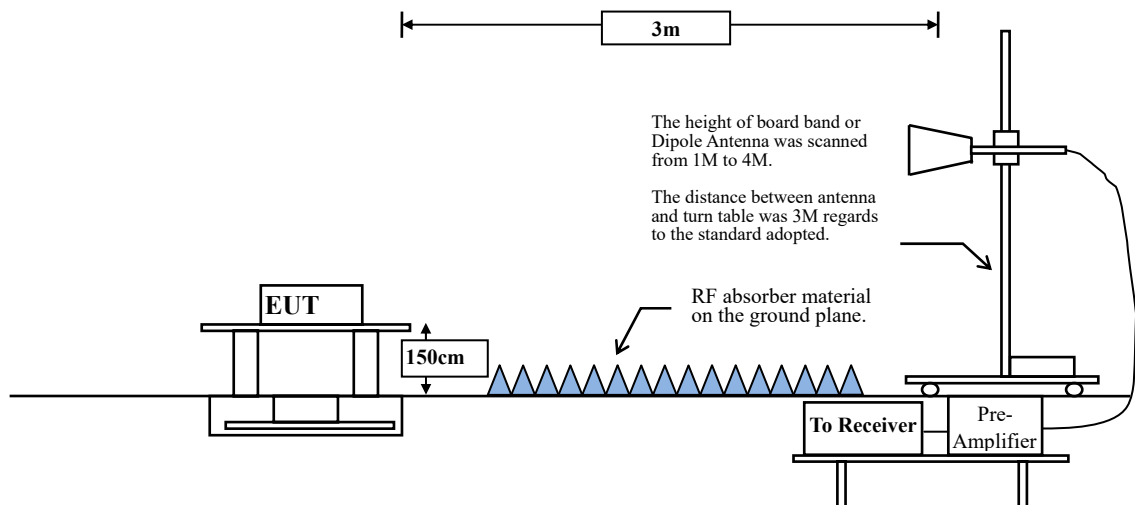

4.2. Limits

➤ General Radiated Emission Limits

Emissions radiated outside of the specified frequency bands, except for harmonics, shall be attenuated by at least 20dB below the level of the fundamental or to the general radiated emission limits in paragraph 15.209, whichever is the lesser attenuation.

FCC Part 15 Subpart C Paragraph 15.209 Limits		
Frequency MHz	Field strength (microvolts/meter)	Measurement distance (meter)
0.009-0.490	2400/F(kHz)	300
0.490-1.705	24000/F(kHz)	30
1.705-30	30	30
30-88	100	3
88-216	150	3
216-960	200	3
Above 960	500	3

- Remarks:
1. RF Voltage (dB μ V) = 20 log RF Voltage (uV)
 2. In the Above Table, the tighter limit applies at the band edges.
 3. Distance refers to the distance in meters between the measuring instrument antenna and the closed point of any part of the device or system.

4.3. Test Procedure

The EUT was setup according to ANSI C63.10: 2013 and tested according to DTS test procedure of KDB558074 for compliance to FCC 47CFR 15.247 requirements.

Measuring the frequency range below 1GHz, the EUT is placed on a turn table which is 0.8 meter above ground, when measuring the frequency range above 1GHz, the EUT is placed on a turn table which is 1.5 meter above ground.

The turn table is rotated 360 degrees to determine the position of the maximum emission level.

The EUT was positioned such that the distance from antenna to the EUT was 3 meters.

The antenna is scanned between 1 meter and 4 meters to find out the maximum emission level. This is repeated for both horizontal and vertical polarization of the antenna. In order to find the maximum emission, all of the interface cables were manipulated according to ANSI C63.10: 2013 on radiated measurement.

The resolution bandwidth below 30MHz setting on the field strength meter is 9kHz and 30MHz~1GHz is 120kHz and above 1GHz is 1MHz.

Radiated emission measurements below 30MHz are made using Loop Antenna and 30MHz~1GHz are made using broadband Bilog antenna and above 1GHz are made using Horn Antennas.

The measurement is divided into the Preliminary Measurement and the Final Measurement.

The suspected frequencies are searched for in Preliminary Measurement with the measurement antenna kept pointed at the source of the emission both in azimuth and elevation, with the polarization of the antenna oriented for maximum response. The antenna is pointed at an angle towards the source of the emission, and the EUT is rotated in both height and polarization to maximize the measured emission. The emission is kept within the illumination area of the 3 dB bandwidth of the antenna.

The measurement frequency range from 9kHz - 10th Harmonic of fundamental was investigated.

RBW and VBW Parameter setting:

According to KDB 558074 section 12.2.4. Peak power measurement procedure

RBW = as specified in Table 1.

$VBW \geq 3 \times RBW$.

Table 1 —RBW as a function of frequency

Frequency	RBW
9-150 kHz	200-300 Hz
0.15-30 MHz	9-10 kHz
30-1000 MHz	100-120 kHz
> 1000 MHz	1 MHz

According to KDB 558074 section 12.2.5. Average power measurement procedure

RBW = 1MHz.

VBW = 10Hz, when duty cycle $\geq 98\%$

$VBW \geq 1/T$, when duty cycle $< 98\%$

(T refers to the minimum transmission duration over which the transmitter is on and is transmitting at its maximum power control level for the tested mode of operation.)

2.4GHz band	Duty Cycle (%)	T (ms)	1/T (Hz)	VBW (Hz)
BLE	100.00	88.1160	11	10

Note: Duty Cycle Refer to Section 9

4.4. Uncertainty

Horizontal polarization :

30-300MHz: $\pm 4.08\text{dB}$; 300M-1GHz: $\pm 3.86\text{dB}$; 1-18GHz: $\pm 3.77\text{dB}$; 18-40GHz: $\pm 3.98\text{dB}$

Vertical polarization :

30-300MHz: $\pm 4.81\text{dB}$; 300M-1GHz: $\pm 3.87\text{dB}$; 1-18GHz: $\pm 3.83\text{dB}$; 18-40GHz: $\pm 3.98\text{dB}$

4.5. Test Result of Radiated Emission

Product : Blood Glucose Monitoring System
 Test Item : Harmonic Radiated Emission
 Test Mode : Mode 1: Transmit - BLE (2402MHz)
 Test Date : 2018/05/18

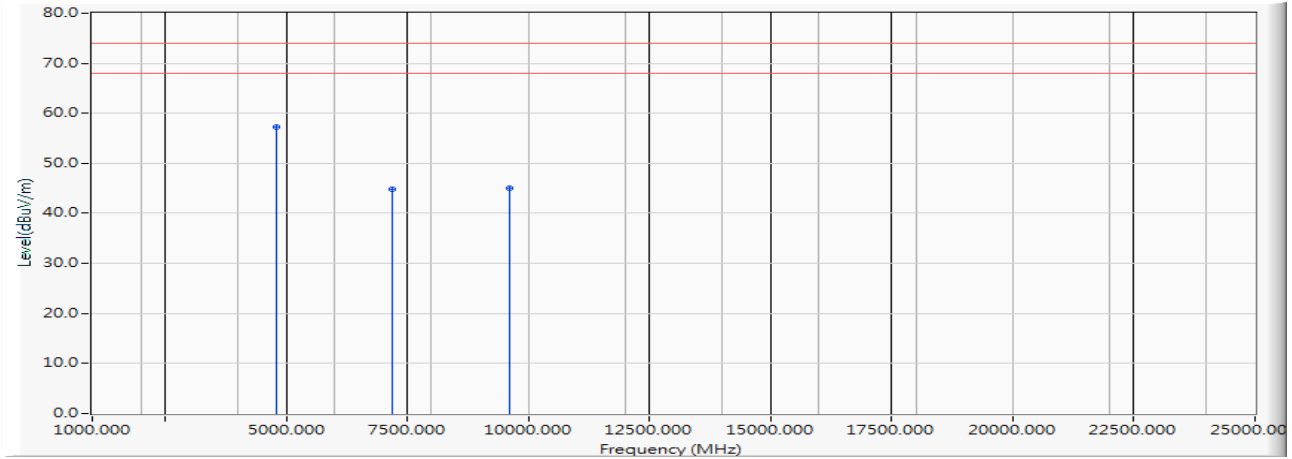

Frequency MHz	Correct Factor dB	Reading Level dBµV	Measurement Level dBµV/m	Margin dB	Limit dBµV/m
Horizontal					
Peak Detector:					
4804.000	-5.050	62.230	57.180	-16.820	74.000
7206.000	-2.558	47.370	44.812	-29.188	74.000
9608.000	-0.456	45.460	45.005	-28.995	74.000
Average					
Detector:					
4804.000	-5.050	58.670	53.620	-0.380	54.000

Note:

1. All Readings below 1GHz are Quasi-Peak, above 1GHz are performed with peak and/or average measurements as necessary.
2. Peak measurements: RBW = 1MHz, VBW = 3 MHz, Sweep: Auto.
3. Average measurements: RBW = 1MHz, VBW = 10 Hz, Sweep: Auto.
4. Measurement Level = Reading Level + Correct Factor.
5. Correct Factor = Antenna factor + Cable loss – Amplifier gain.
6. The average measurement was not performed when the peak measured data under the limit of average detection.
7. The emission levels of other frequencies are very lower than the limit and not show in test report.

Product : Blood Glucose Monitoring System
 Test Item : Harmonic Radiated Emission
 Test Mode : Mode 1: Transmit - BLE (2402MHz)
 Test Date : 2018/05/18

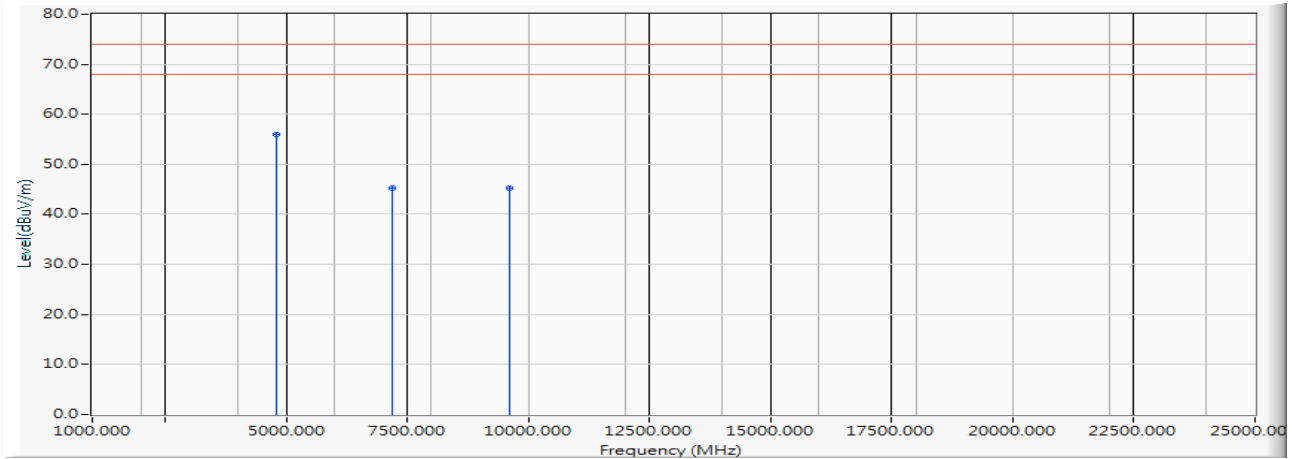

Frequency MHz	Correct Factor dB	Reading Level dBµV	Measurement Level dBµV/m	Margin dB	Limit dBµV/m
Vertical					
Peak Detector:					
4804.000	-5.050	60.930	55.880	-18.120	74.000
7206.000	-2.558	47.800	45.242	-28.758	74.000
9608.000	-0.456	45.640	45.185	-28.815	74.000
Average					
Detector:					
4804.000	-5.050	57.080	52.030	-1.970	54.000

Note:

1. All Readings below 1GHz are Quasi-Peak, above 1GHz are performed with peak and/or average measurements as necessary.
2. Peak measurements: RBW = 1MHz, VBW = 3 MHz, Sweep: Auto.
3. Average measurements: RBW = 1MHz, VBW = 10 Hz, Sweep: Auto.
4. Measurement Level = Reading Level + Correct Factor.
5. Correct Factor = Antenna factor + Cable loss – Amplifier gain.
6. The average measurement was not performed when the peak measured data under the limit of average detection.
7. The emission levels of other frequencies are very lower than the limit and not show in test report.

Product : Blood Glucose Monitoring System
 Test Item : Harmonic Radiated Emission
 Test Mode : Mode 1: Transmit - BLE (2440MHz)
 Test Date : 2018/05/18

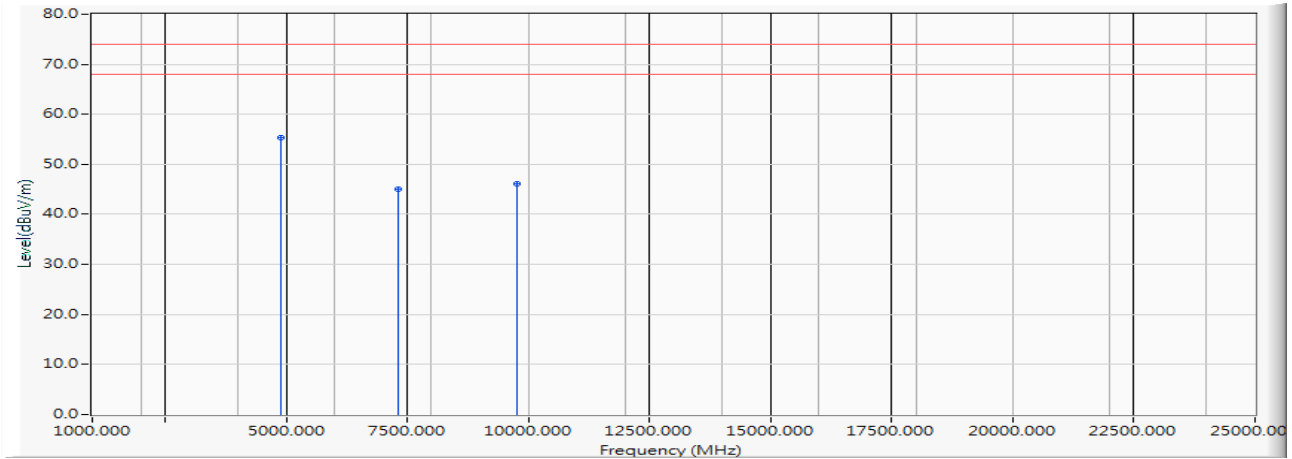

Frequency MHz	Correct Factor dB	Reading Level dBµV	Measurement Level dBµV/m	Margin dB	Limit dBµV/m
Horizontal					
Peak Detector:					
4880.000	-5.025	60.360	55.334	-18.666	74.000
7320.000	-2.522	47.490	44.968	-29.032	74.000
9760.000	-0.134	46.320	46.185	-27.815	74.000
Average					
Detector:					
4880.000	-5.025	56.350	51.324	-2.676	54.000

Note:

1. All Readings below 1GHz are Quasi-Peak, above 1GHz are performed with peak and/or average measurements as necessary.
2. Peak measurements: RBW = 1MHz, VBW = 3 MHz, Sweep: Auto.
3. Average measurements: RBW = 1MHz, VBW = 10 Hz, Sweep: Auto.
4. Measurement Level = Reading Level + Correct Factor.
5. Correct Factor = Antenna factor + Cable loss – Amplifier gain.
6. The average measurement was not performed when the peak measured data under the limit of average detection.
7. The emission levels of other frequencies are very lower than the limit and not show in test report.

Product : Blood Glucose Monitoring System
 Test Item : Harmonic Radiated Emission
 Test Mode : Mode 1: Transmit - BLE (2440MHz)
 Test Date : 2018/05/18

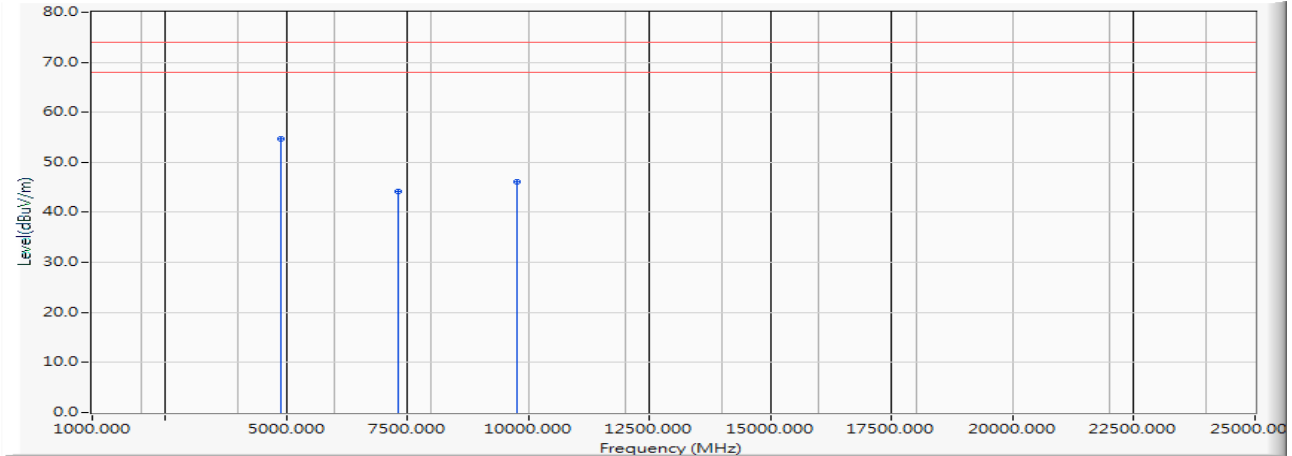

Frequency MHz	Correct Factor dB	Reading Level dBµV	Measurement Level dBµV/m	Margin dB	Limit dBµV/m
Vertical					
Peak Detector:					
4880.000	-5.025	59.640	54.614	-19.386	74.000
7320.000	-2.522	46.620	44.098	-29.902	74.000
9760.000	-0.134	46.150	46.015	-27.985	74.000
Average					
Detector:					
4880.000	-5.025	55.290	50.264	-3.736	54.000

Note:

1. All Readings below 1GHz are Quasi-Peak, above 1GHz are performed with peak and/or average measurements as necessary.
2. Peak measurements: RBW = 1MHz, VBW = 3 MHz, Sweep: Auto.
3. Average measurements: RBW = 1MHz, VBW = 10 Hz, Sweep: Auto.
4. Measurement Level = Reading Level + Correct Factor.
5. Correct Factor = Antenna factor + Cable loss – Amplifier gain.
6. The average measurement was not performed when the peak measured data under the limit of average detection.
7. The emission levels of other frequencies are very lower than the limit and not show in test report.

Product : Blood Glucose Monitoring System
 Test Item : Harmonic Radiated Emission
 Test Mode : Mode 1: Transmit - BLE (2480MHz)
 Test Date : 2018/05/18

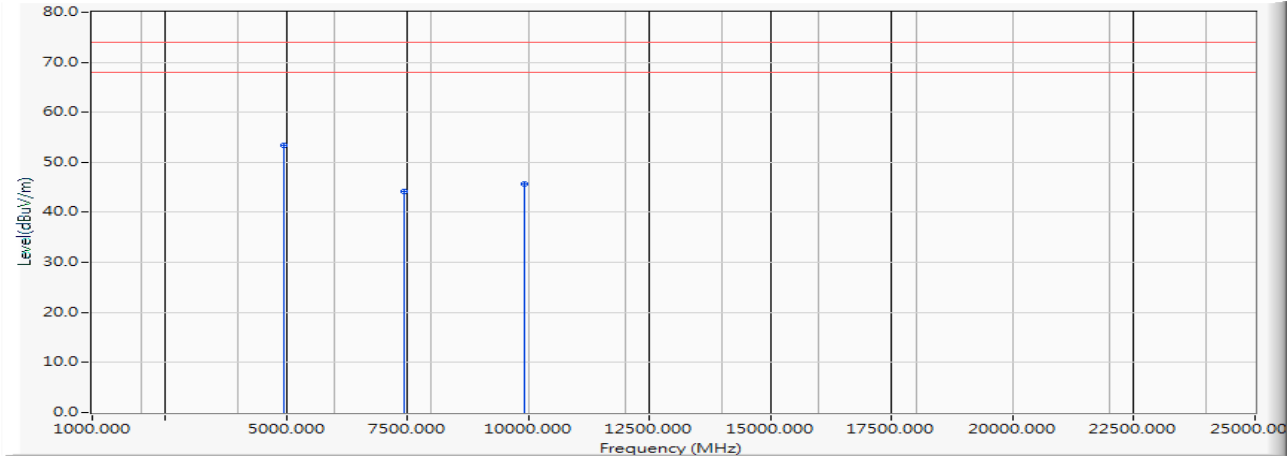

Frequency MHz	Correct Factor dB	Reading Level dBµV	Measurement Level dBµV/m	Margin dB	Limit dBµV/m
Horizontal					
Peak Detector:					
4960.000	-5.035	58.480	53.445	-20.555	74.000
7440.000	-2.406	46.650	44.244	-29.756	74.000
9920.000	0.139	45.610	45.749	-28.251	74.000
Average					
Detector:					
--					54.000

Note:

- All Readings below 1GHz are Quasi-Peak, above 1GHz are performed with peak and/or average measurements as necessary.
- Peak measurements: RBW = 1MHz, VBW = 3 MHz, Sweep: Auto.
- Average measurements: RBW = 1MHz, VBW = 10 Hz, Sweep: Auto.
- Measurement Level = Reading Level + Correct Factor.
- Correct Factor = Antenna factor + Cable loss – Amplifier gain.
- The average measurement was not performed when the peak measured data under the limit of average detection.
- The emission levels of other frequencies are very lower than the limit and not show in test report.

Product : Blood Glucose Monitoring System
 Test Item : Harmonic Radiated Emission
 Test Mode : Mode 1: Transmit - BLE (2480MHz)
 Test Date : 2018/05/18

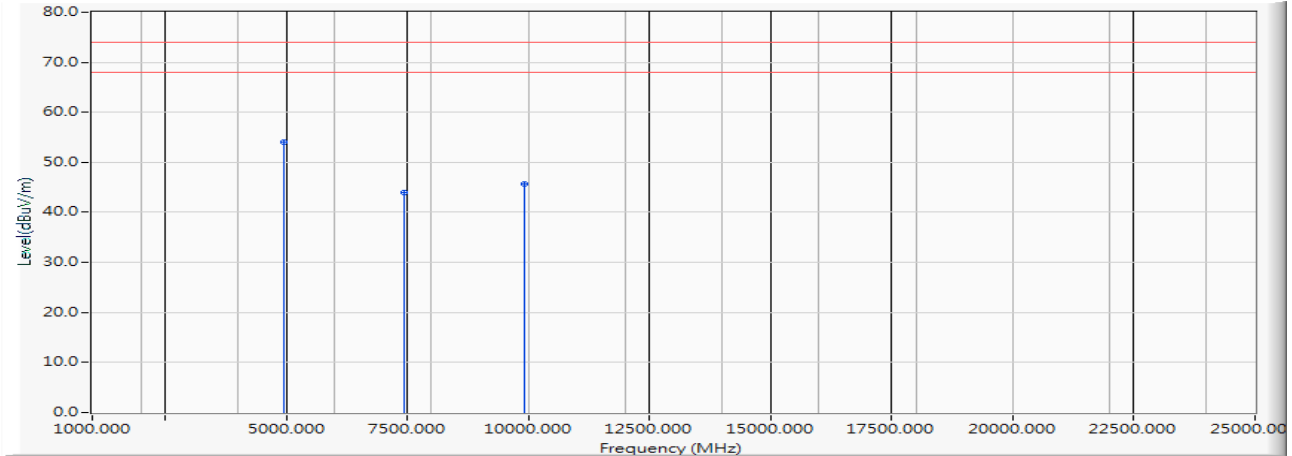

Frequency MHz	Correct Factor dB	Reading Level dBμV	Measurement Level dBμV/m	Margin dB	Limit dBμV/m
Vertical					
Peak Detector:					
4960.000	-5.035	59.170	54.135	-19.865	74.000
7440.000	-2.406	46.480	44.074	-29.926	74.000
9920.000	0.139	45.510	45.649	-28.351	74.000
Average					
Detector:					
4960.000	-5.035	54.710	49.675	-4.325	54.000

Note:

1. All Readings below 1GHz are Quasi-Peak, above 1GHz are performed with peak and/or average measurements as necessary.
2. Peak measurements: RBW = 1MHz, VBW = 3 MHz, Sweep: Auto.
3. Average measurements: RBW = 1MHz, VBW = 10 Hz, Sweep: Auto.
4. Measurement Level = Reading Level + Correct Factor.
5. Correct Factor = Antenna factor + Cable loss – Amplifier gain.
6. The average measurement was not performed when the peak measured data under the limit of average detection.
7. The emission levels of other frequencies are very lower than the limit and not show in test report.

Product : Blood Glucose Monitoring System
 Test Item : General Radiated Emission
 Test Mode : Mode 1: Transmit - BLE (2440MHz)
 Test Date : 2018/05/18

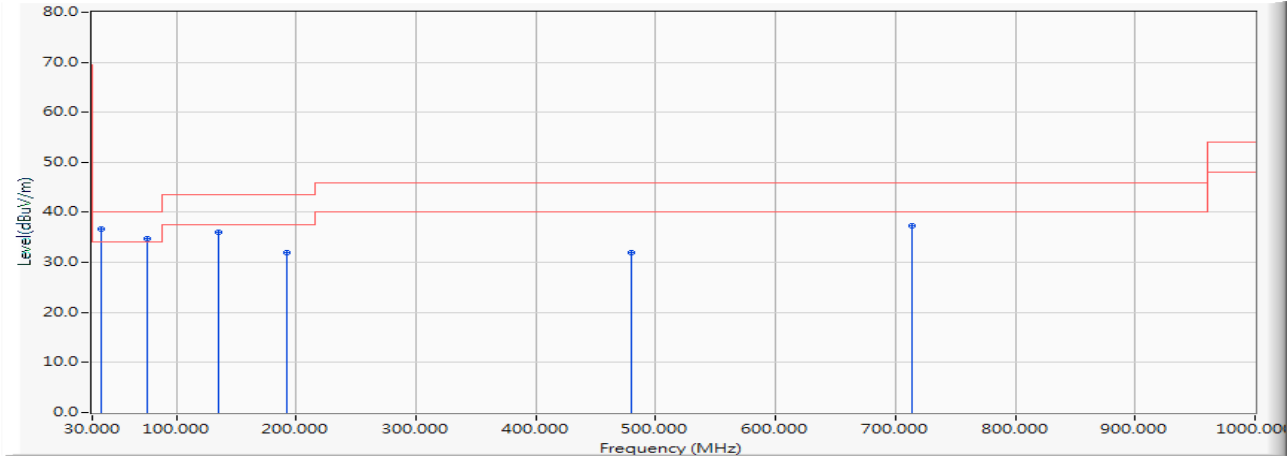

Frequency MHz	Correct Factor dB	Reading Level dBµV	Measurement Level dBµV/m	Margin dB	Limit dBµV/m
Horizontal					
37.029	-11.549	48.231	36.682	-3.318	40.000
76.391	-14.893	49.742	34.849	-5.151	40.000
135.435	-11.872	47.921	36.049	-7.451	43.500
191.667	-13.656	45.623	31.966	-11.534	43.500
479.855	-6.356	38.347	31.991	-14.009	46.000
713.217	-2.795	40.209	37.413	-8.587	46.000

Note:

1. All Readings below 1GHz are Quasi-Peak, above 1GHz are performed with peak and/or average measurements as necessary.
2. Peak measurements: RBW = 1MHz, VBW = 3 MHz, Sweep: Auto.
3. Average measurements: RBW = 1MHz, VBW = 10 Hz, Sweep: Auto.
4. Measurement Level = Reading Level + Correct Factor.
5. Correct Factor = Antenna factor + Cable loss – Amplifier gain.
6. The average measurement was not performed when the peak measured data under the limit of average detection.
7. The emission levels of other frequencies are very lower than the limit and not show in test report.
8. No emission found between lowest internal used/generated frequency to 30MHz.

Product : Blood Glucose Monitoring System
 Test Item : General Radiated Emission
 Test Mode : Mode 1: Transmit - BLE (2440MHz)
 Test Date : 2018/05/18

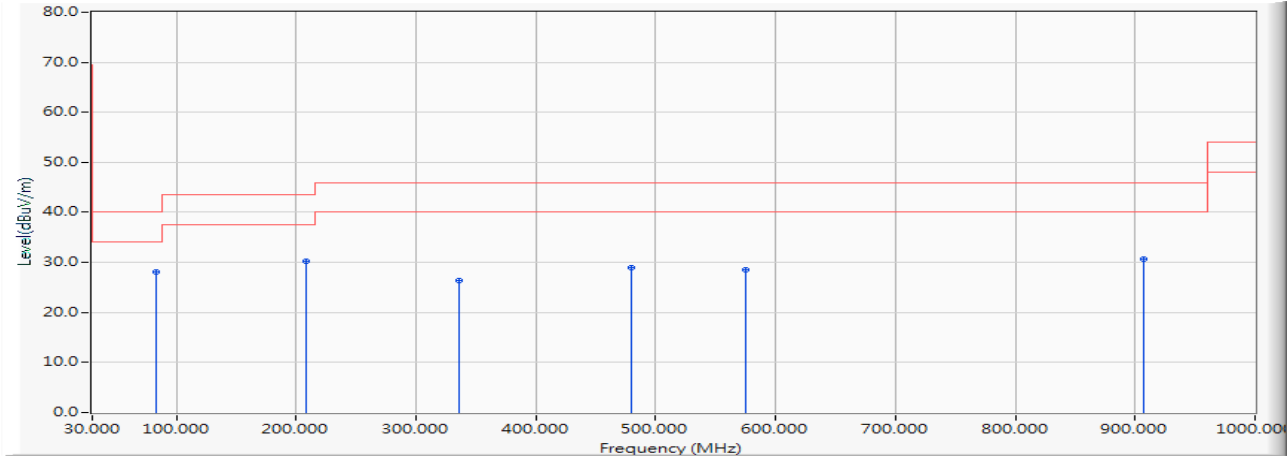

Frequency MHz	Correct Factor dB	Reading Level dBμV	Measurement Level dBμV/m	Margin dB	Limit dBμV/m
Vertical					
83.420	-16.296	44.464	28.168	-11.832	40.000
208.536	-13.590	43.785	30.195	-13.305	43.500
336.464	-9.521	35.801	26.280	-19.720	46.000
479.855	-6.356	35.387	29.031	-16.969	46.000
575.449	-4.635	33.221	28.585	-17.415	46.000
907.217	-0.243	30.861	30.618	-15.382	46.000

Note:

1. All Readings below 1GHz are Quasi-Peak, above 1GHz are performed with peak and/or average measurements as necessary.
2. Peak measurements: RBW = 1MHz, VBW = 3 MHz, Sweep: Auto.
3. Average measurements: RBW = 1MHz, VBW = 10 Hz, Sweep: Auto.
4. Measurement Level = Reading Level + Correct Factor.
5. Correct Factor = Antenna factor + Cable loss – Amplifier gain.
6. The average measurement was not performed when the peak measured data under the limit of average detection.
7. The emission levels of other frequencies are very lower than the limit and not show in test report.
8. No emission found between lowest internal used/generated frequency to 30MHz.

5. RF Antenna Conducted Test

5.1. Test Setup

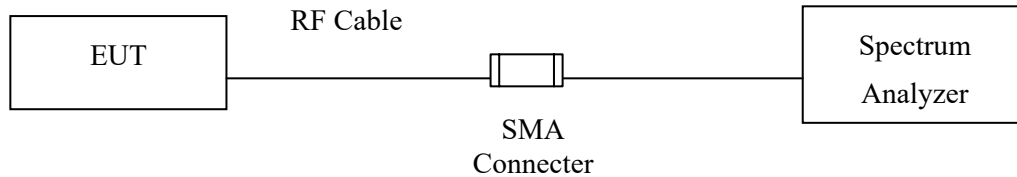

5.2. Limits

According to FCC Section 15.247(d). In any 100 kHz bandwidth outside the frequency band in which the spread spectrum or digitally modulated intentional radiator is operating, the radio frequency power that is produced by the intentional radiator shall be at least 20 dB below that in the 100 kHz bandwidth within the band that contains the highest level of the desired power, based on either an RF conducted or measurement, provided the transmitter demonstrates compliance with the peak conducted power limits. If the transmitter complies with the conducted power limits based on the use of RMS averaging over a time interval, the attenuation required under this paragraph shall be 30 dB instead of 20 dB.

5.3. Test Procedure

The EUT was tested according to DTS test procedure of KDB558074 for compliance to FCC 47CFR 15.247 requirements.

Set RBW = 100 kHz, Set VBW > RBW, scan up through 10th harmonic.

5.4. Uncertainty

±1.23dB

5.5. Test Result of RF Antenna Conducted Test

Product : Blood Glucose Monitoring System
Test Item : RF Antenna Conducted Test
Test Mode : Mode 1: Transmit - BLE
Test Date : 2018/05/11

Figure Channel 00:

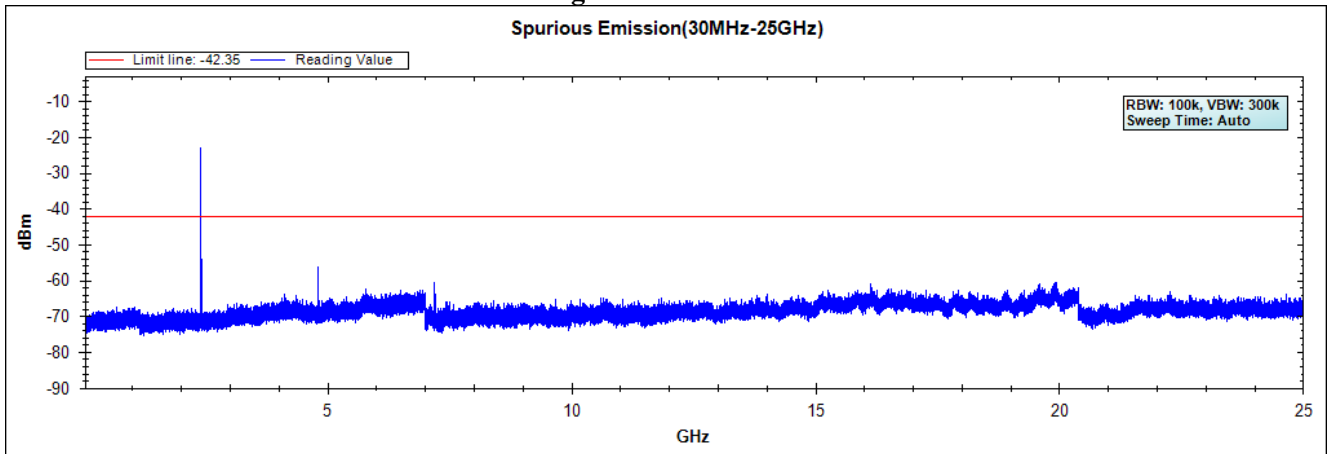

Figure Channel 19:

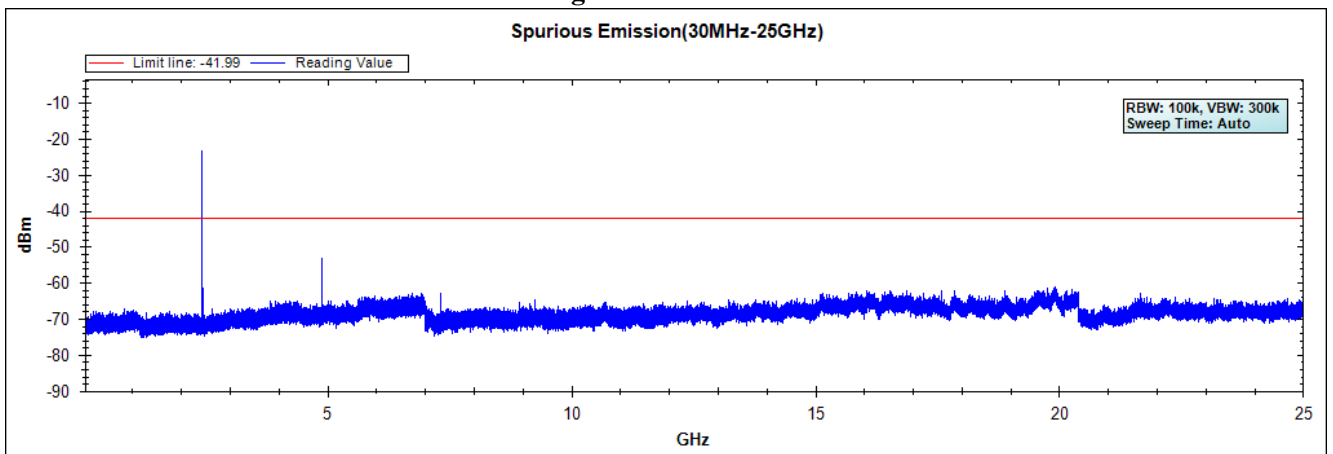
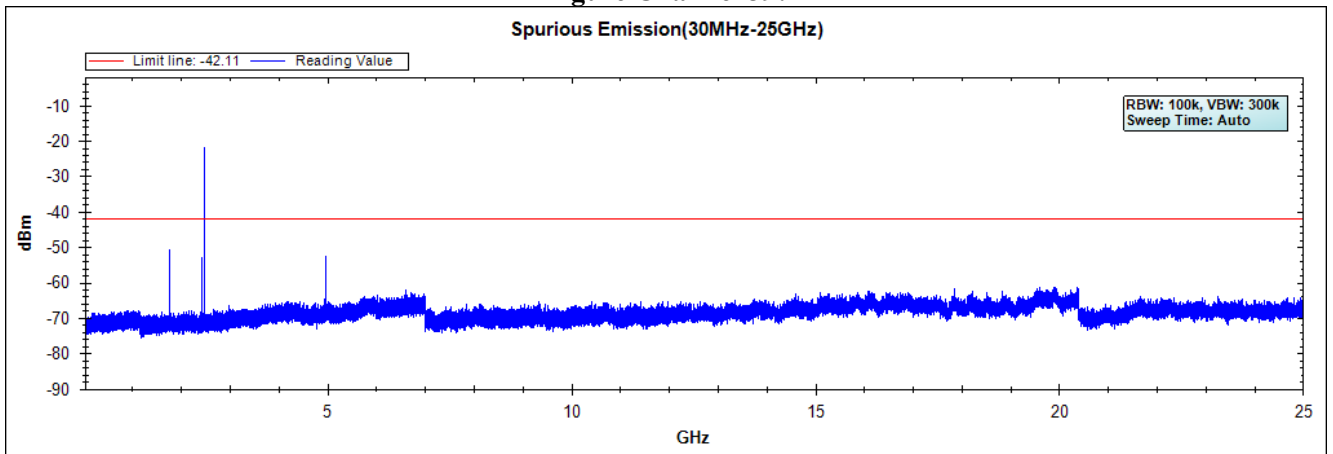

Figure Channel 39:



Note: The above test pattern is synthesized by multiple of the frequency range.

6. Band Edge

6.1. Test Setup

RF Conducted Measurement

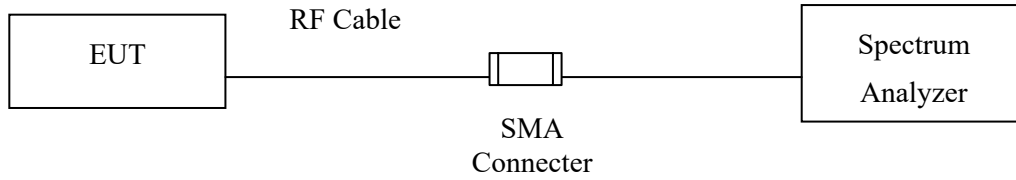

RF Radiated Measurement:

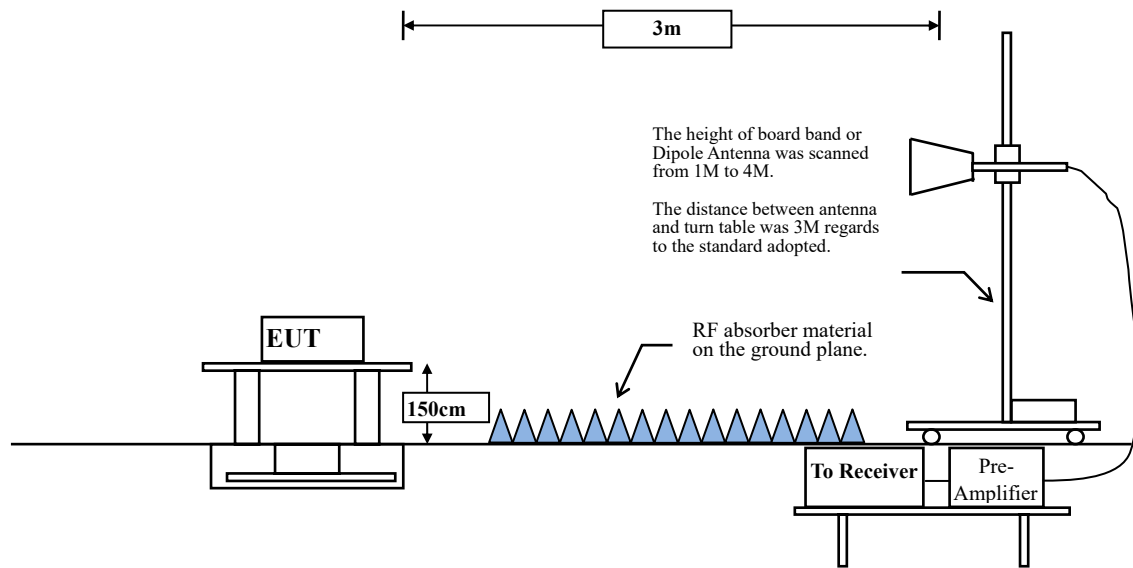

6.2. Limit

According to FCC Section 15.247(d). In any 100 kHz bandwidth outside the frequency band in which the spread spectrum or digitally modulated intentional radiator is operating, the radio frequency power that is produced by the intentional radiator shall be at least 20 dB below that in the 100 kHz bandwidth within the band that contains the highest level of the desired power, based on either an RF conducted or measurement, provided the transmitter demonstrates compliance with the peak conducted power limits. If the transmitter complies with the conducted power limits based on the use of RMS averaging over a time interval, the attenuation required under this paragraph shall be 30 dB instead of 20 dB. Attenuation below the general limits specified in Section 15.209(a) is not required. In addition, radiated emissions which fall in the restricted bands, as defined in Section 15.205(a), must also comply with the radiated emission limits specified in Section 15.209(a) (see Section 15.205(c)).

6.3. Test Procedure

The EUT was setup according to ANSI C63.10, 2013 and tested according to DTS test procedure of KDB558074 for compliance to FCC 47CFR 15.247 requirements.

The EUT is placed on a turn table which is 1.5 meter above ground. The turn table is rotated 360 degrees to determine the position of the maximum emission level. The EUT was positioned such that the distance from antenna to the EUT was 3 meters.

The antenna is scanned from 1 meter to 4 meters to find out the maximum emission level. This is repeated for both horizontal and vertical polarization of the antenna. In order to find the maximum emission, all of the interface cables were manipulated according to ANSI C63.10:2013 on radiated measurement.

RBW and VBW Parameter setting:

According to KDB 558074 section 12.2.4. Peak power measurement procedure

RBW = as specified in Table 1.

$VBW \geq 3 \times RBW$.

Table 1 —RBW as a function of frequency

Frequency	RBW
9-150 kHz	200-300 Hz
0.15-30 MHz	9-10 kHz
30-1000 MHz	100-120 kHz
> 1000 MHz	1 MHz

According to KDB 558074 section 12.2.5. Average power measurement procedure

RBW = 1MHz.

VBW = 10Hz, when duty cycle $\geq 98\%$

$VBW \geq 1/T$, when duty cycle $< 98\%$

(T refers to the minimum transmission duration over which the transmitter is on and is transmitting at its maximum power control level for the tested mode of operation.)

2.4GHz band	Duty Cycle (%)	T (ms)	1/T (Hz)	VBW (Hz)
BLE	100.00	88.1160	11	10

Note: Duty Cycle Refer to Section 9

6.4. Uncertainty

Conducted: $\pm 1.23\text{dB}$

Radiated:

Horizontal polarization : 1-18GHz: $\pm 3.77\text{dB}$

Vertical polarization : 1-18GHz : $\pm 3.83\text{dB}$

6.5. Test Result of Band Edge

Product : Blood Glucose Monitoring System
 Test Item : Band Edge
 Test Mode : Mode 1: Transmit - BLE (2402MHz)
 Test Date : 2018/05/18

RF Radiated Measurement (Horizontal):

Channel No.	Frequency (MHz)	Correct Factor (dB)	Reading Level (dBμV)	Emission Level (dBμV/m)	Peak Limit (dBμV/m)	Average Limit (dBμV/m)	Result
00 (Peak)	2387.826	10.253	31.981	42.234	74.00	54.00	Pass
00 (Peak)	2390.000	10.262	31.078	41.340	74.00	54.00	Pass
00 (Peak)	2400.000	10.304	50.384	60.687	--	--	--
00 (Peak)	2402.174	10.312	79.002	89.314	--	--	--
00 (Average)	2370.000	10.182	18.936	29.118	74.00	54.00	Pass
00 (Average)	2390.000	10.262	18.342	28.604	74.00	54.00	Pass
00 (Average)	2400.000	10.304	42.117	52.420	--	--	--
00 (Average)	2402.029	10.312	78.162	88.474	--	--	--

Figure Channel 00: Horizontal (Peak)

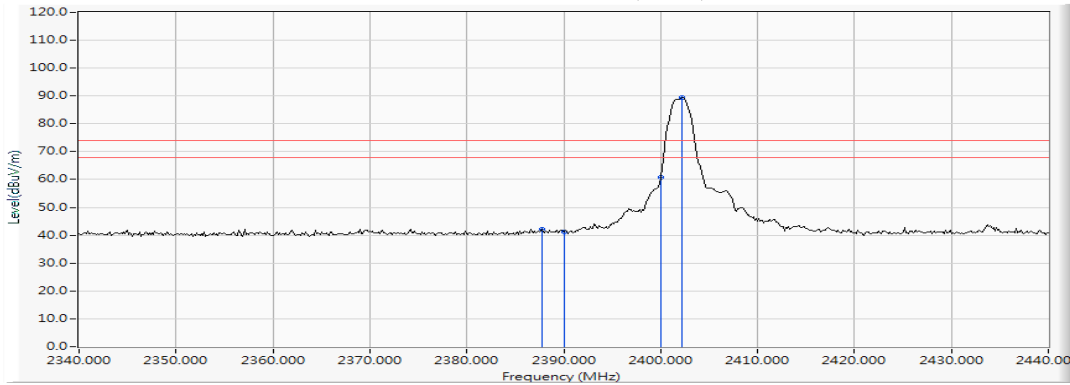
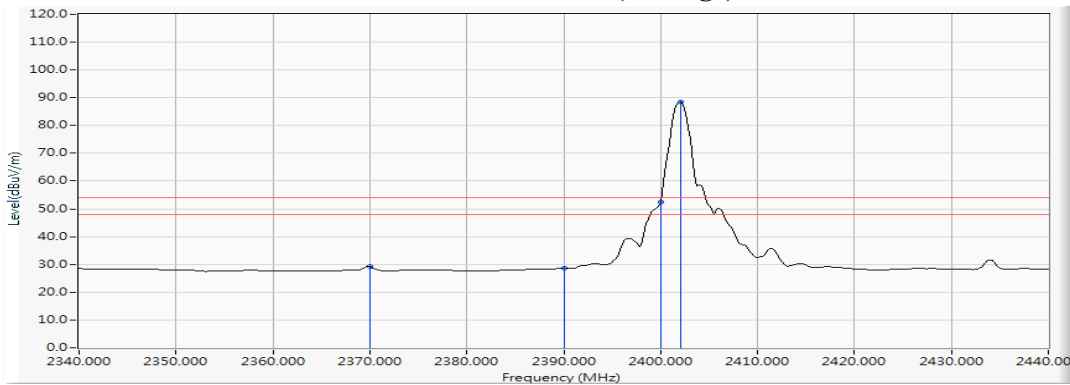

Figure Channel 00: Horizontal (Average)



Note:

1. All readings above 1GHz are performed with peak and/or average measurements as necessary.
2. Peak measurements: RBW = 1MHz, VBW = 3 MHz, Sweep: Auto.
3. Average measurements: RBW = 1MHz, VBW = 10 Hz, Sweep: Auto.
4. “ * ”, means this data is the worst emission level.
5. Measurement Level = Reading Level + Correct Factor.
6. The average measurement was not performed when the peak measured data under the limit of average detection.

Product : Blood Glucose Monitoring System
 Test Item : Band Edge
 Test Mode : Mode 1: Transmit - BLE (2402MHz)
 Test Date : 2018/05/18

RF Radiated Measurement (Vertical):

Channel No.	Frequency (MHz)	Correct Factor (dB)	Reading Level (dBμV)	Emission Level (dBμV/m)	Peak Limit (dBμV/m)	Average Limit (dBμV/m)	Result
00 (Peak)	2342.899	10.067	33.308	43.375	74.00	54.00	Pass
00 (Peak)	2390.000	10.262	31.963	42.225	74.00	54.00	Pass
00 (Peak)	2400.000	10.304	51.967	62.270	--	--	--
00 (Peak)	2402.174	10.312	80.683	90.995	--	--	--
00 (Average)	2369.855	10.181	21.071	31.253	74.00	54.00	Pass
00 (Average)	2390.000	10.262	18.816	29.078	74.00	54.00	Pass
00 (Average)	2400.000	10.304	43.702	54.005	--	--	--
00 (Average)	2402.029	10.312	79.830	90.142	--	--	--

Figure Channel 00: Vertical (Peak)

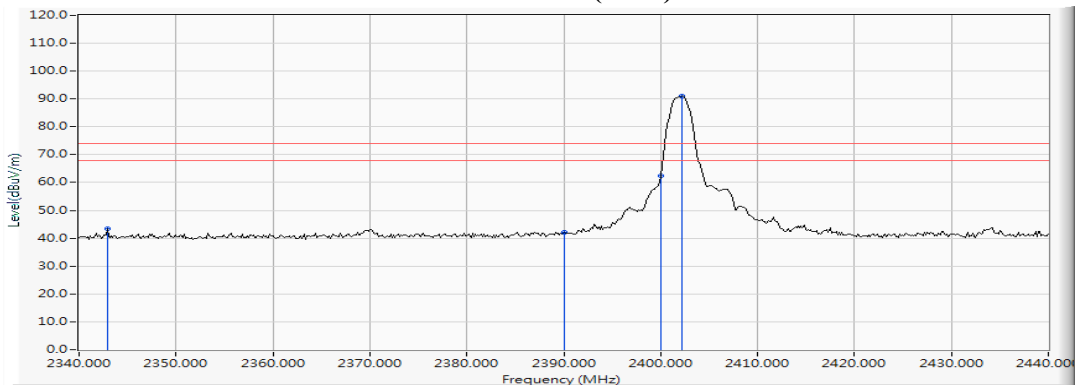
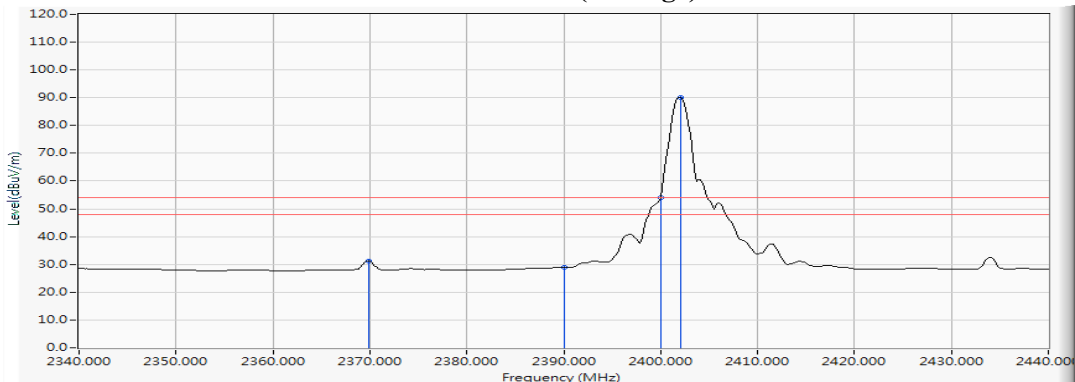

Figure Channel 00: Vertical (Average)



Note:

1. All readings above 1GHz are performed with peak and/or average measurements as necessary.
2. Peak measurements: RBW = 1MHz, VBW = 3 MHz, Sweep: Auto.
3. Average measurements: RBW = 1MHz, VBW = 10 Hz, Sweep: Auto.
4. “ * ”, means this data is the worst emission level.
5. Measurement Level = Reading Level + Correct Factor.
6. The average measurement was not performed when the peak measured data under the limit of average detection.

Product : Blood Glucose Monitoring System
 Test Item : Band Edge
 Test Mode : Mode 1: Transmit - BLE (2480MHz)
 Test Date : 2018/05/18

RF Radiated Measurement (Horizontal):

Channel No.	Frequency (MHz)	Correct Factor (dB)	Reading Level (dBμV)	Emission Level (dBμV/m)	Peak Limit (dBμV/m)	Average Limit (dBμV/m)	Result
39 (Peak)	2479.732	10.627	77.717	88.344	--	--	--
39 (Peak)	2483.500	10.640	37.807	48.448	74.00	54.00	Pass
39 (Average)	2480.022	10.628	76.795	87.423	--	--	--
39 (Average)	2483.500	10.640	29.858	40.499	74.00	54.00	Pass

Figure Channel 39: Horizontal (Peak)

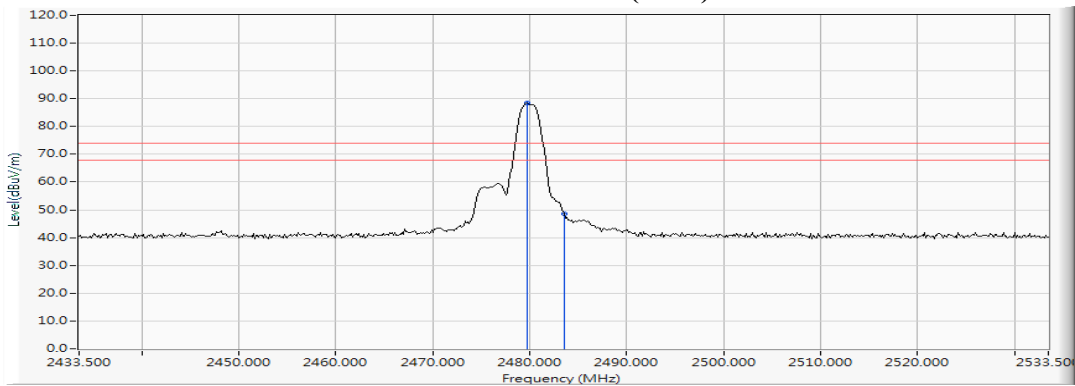
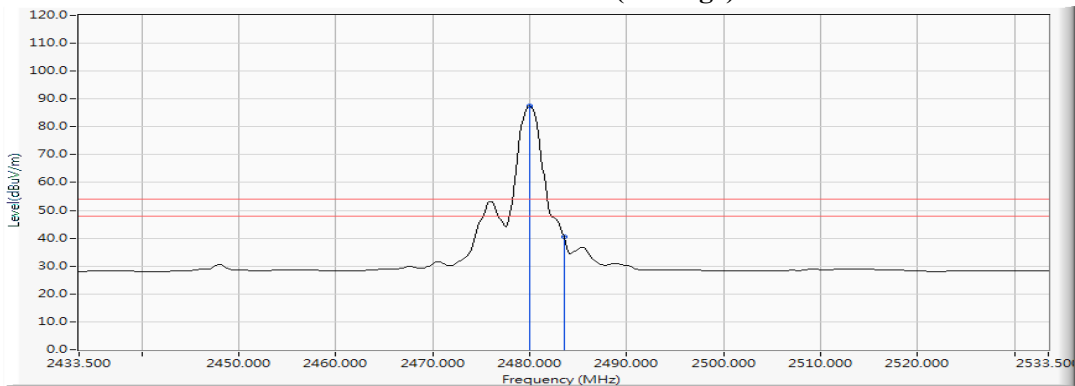

Figure Channel 39: Horizontal (Average)



Note:

1. All readings above 1GHz are performed with peak and/or average measurements as necessary.
2. Peak measurements: RBW = 1MHz, VBW = 3 MHz, Sweep: Auto.
3. Average measurements: RBW = 1MHz, VBW = 10 Hz, Sweep: Auto.
4. “ * ”, means this data is the worst emission level.
5. Measurement Level = Reading Level + Correct Factor.
6. The average measurement was not performed when the peak measured data under the limit of average detection.

Product : Blood Glucose Monitoring System
 Test Item : Band Edge
 Test Mode : Mode 1: Transmit - BLE (2480MHz)
 Test Date : 2018/05/18

RF Radiated Measurement (Vertical):

Channel No.	Frequency (MHz)	Correct Factor (dB)	Reading Level (dBμV)	Emission Level (dBμV/m)	Peak Limit (dBμV/m)	Average Limit (dBμV/m)	Result
39 (Peak)	2479.732	10.627	77.179	87.806	--	--	--
39 (Peak)	2483.500	10.640	37.293	47.934	74.00	54.00	Pass
39 (Average)	2480.022	10.628	76.235	86.863	--	--	--
39 (Average)	2483.500	10.640	29.216	39.857	74.00	54.00	Pass

Figure Channel 39: Vertical (Peak)

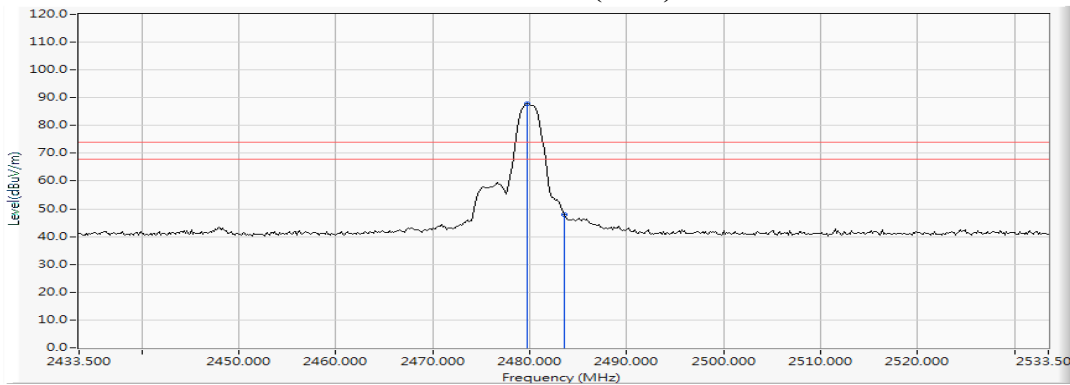
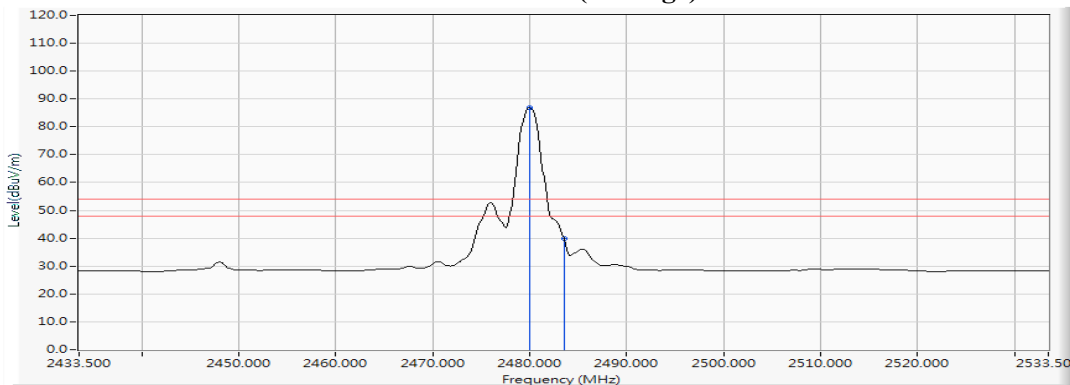

Figure Channel 39: Vertical (Average)



Note:

1. All readings above 1GHz are performed with peak and/or average measurements as necessary.
2. Peak measurements: RBW = 1MHz, VBW = 3 MHz, Sweep: Auto.
3. Average measurements: RBW = 1MHz, VBW = 10 Hz, Sweep: Auto.
4. “ * ”, means this data is the worst emission level.
5. Measurement Level = Reading Level + Correct Factor.
6. The average measurement was not performed when the peak measured data under the limit of average detection.

7. 6dB Bandwidth

7.1. Test Setup

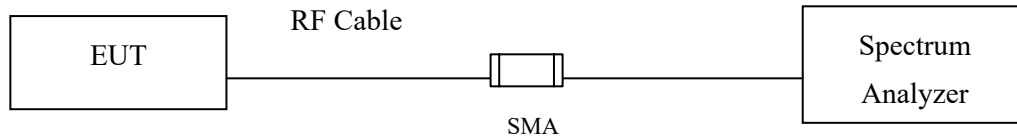

7.2. Limits

The minimum bandwidth shall be at least 500 kHz.

7.3. Test Procedure

The EUT was setup according to ANSI C63.10 2013; tested according to DTS test procedure of KDB558074 for compliance to FCC 47CFR 15.247 requirements.

Set RBW = 1-5% of the emission bandwidth, $VBW \geq 3 * RBW$

7.4. Uncertainty

$\pm 279.2\text{Hz}$

7.5. Test Result of 6dB Bandwidth

Product : Blood Glucose Monitoring System
 Test Item : 6dB Bandwidth Data
 Test Mode : Mode 1: Transmit - BLE

Channel No.	Frequency (MHz)	Measurement Level (kHz)	Required Limit (kHz)	Result
00	2402	750	>500	Pass
19	2440	760	>500	Pass
39	2480	730	>500	Pass

Figure Channel 00:

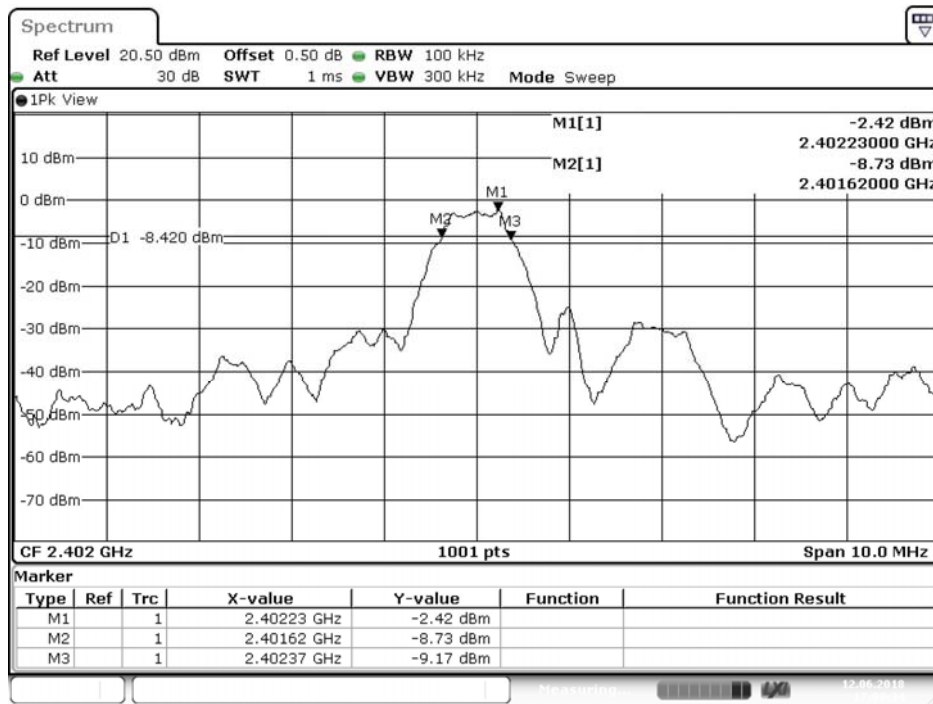

Date: 12 JUN.2018 17:08:35

Figure Channel 19:

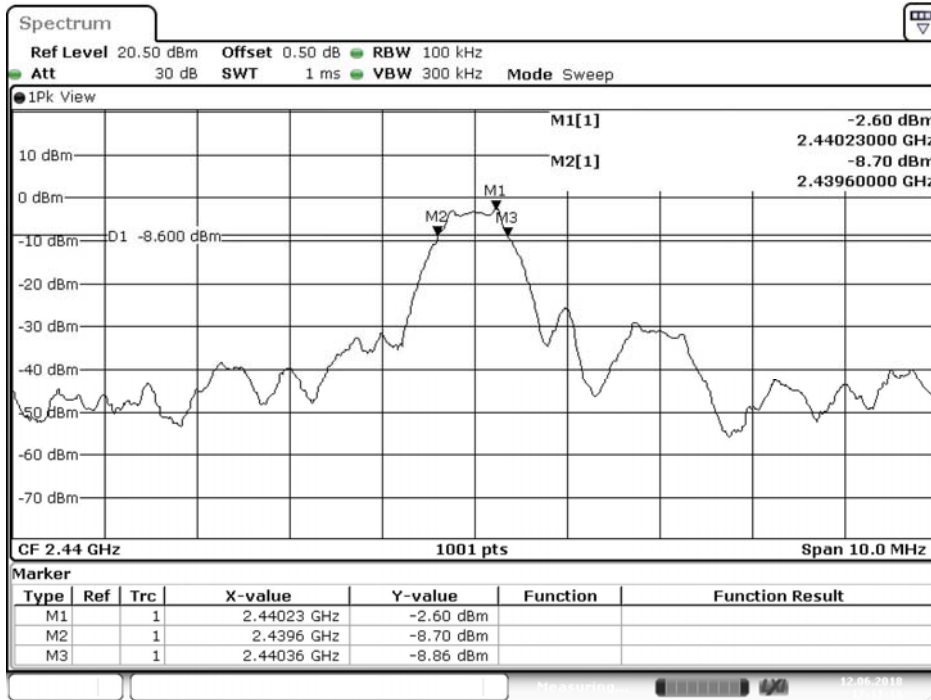

Date: 12 JUN 2018 17:11:19

Figure Channel 39:

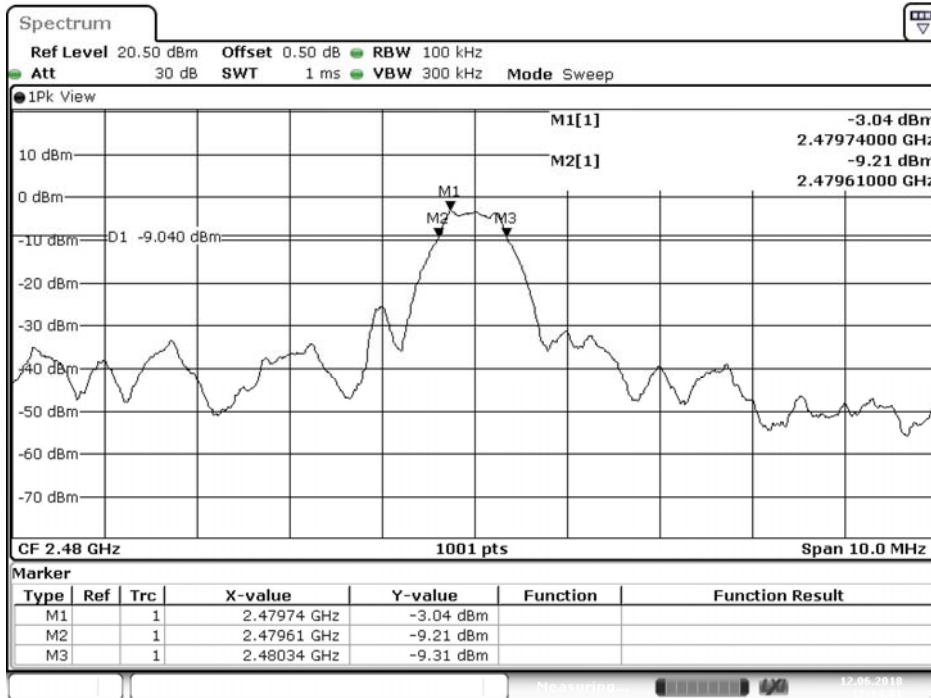

Date: 12 JUN 2018 17:14:01

8. Power Density

8.1. Test Setup

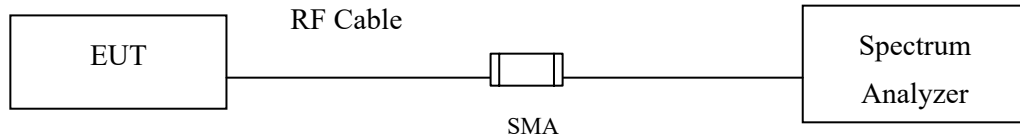

8.2. Limits

The transmitted power density averaged over any 1 second interval shall not be greater +8dBm in any 3kHz bandwidth.

8.3. Test Procedure

The EUT was setup according to ANSI C63.10: 2013, the maximum power spectral density using KDB 558074 section 10.2 PKPSD (peak PSD) method.

8.4. Uncertainty

$\pm 1.23\text{dB}$

8.5. Test Result of Power Density

Product : Blood Glucose Monitoring System
 Test Item : Power Density Data
 Test Mode : Mode 1: Transmit - BLE

Channel No.	Frequency (MHz)	Measure Level (dBm)	Limit (dBm)	Result
00	2402	-2.300	≤ 8dBm	Pass
19	2440	-2.540	≤ 8dBm	Pass
39	2480	-2.800	≤ 8dBm	Pass

Figure Channel 00:

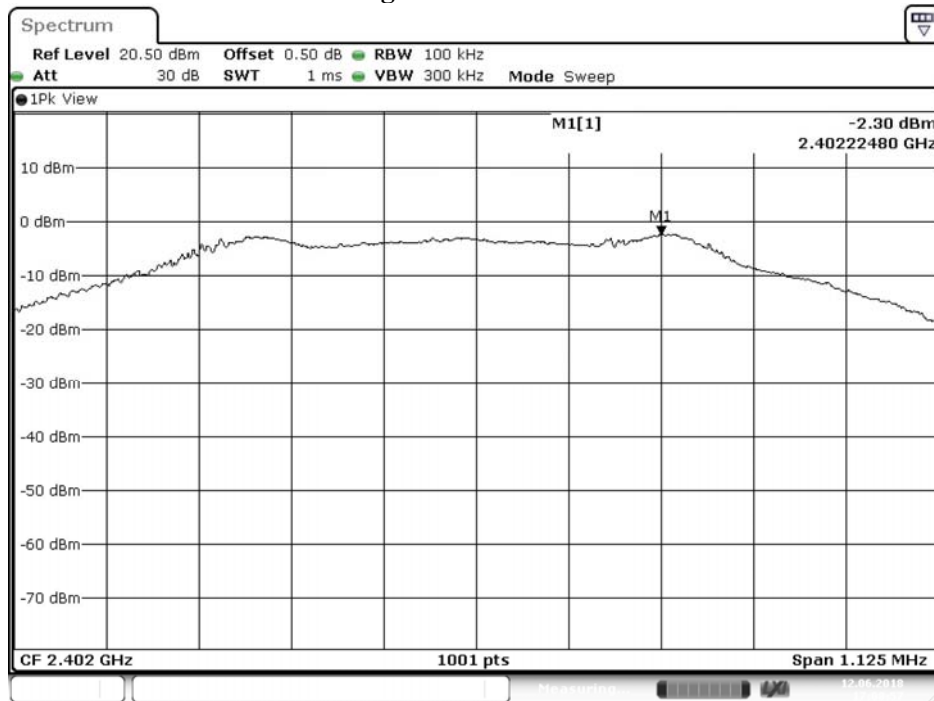

Date: 12 JUN 2018 17:08:57

Figure Channel 19:

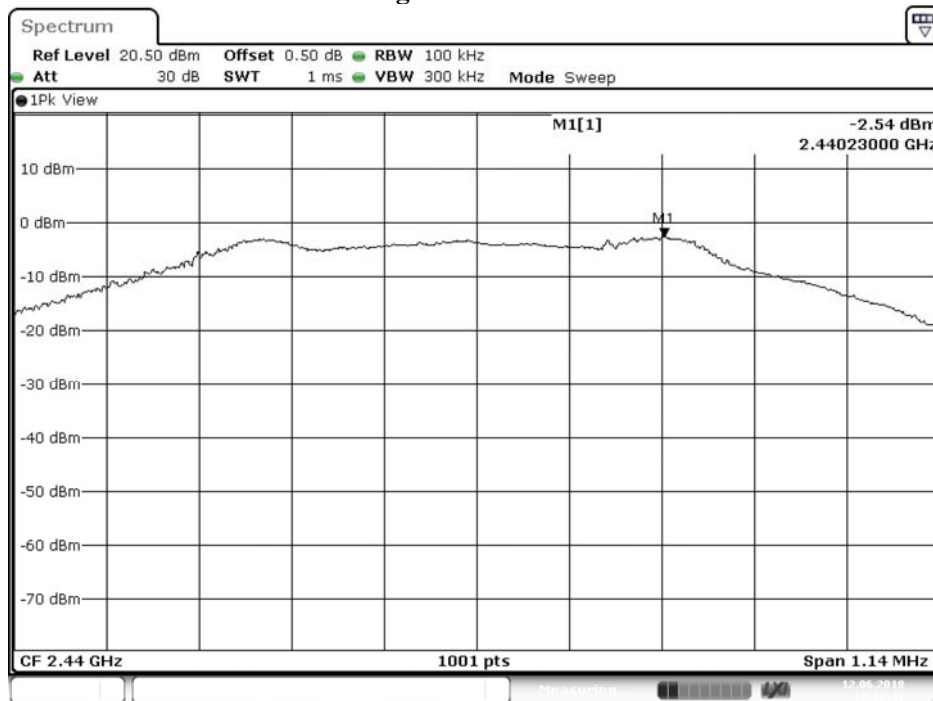

Date: 12 JUN.2018 17:11:41

Figure Channel 39:

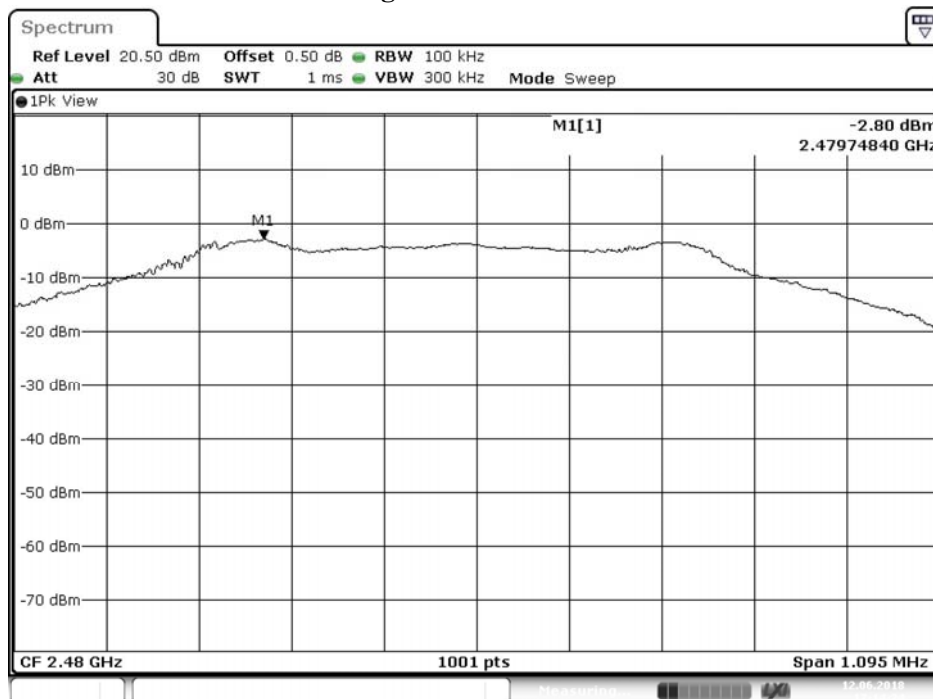

Date: 12 JUN.2018 17:14:24

9. Duty Cycle

9.1. Test Setup

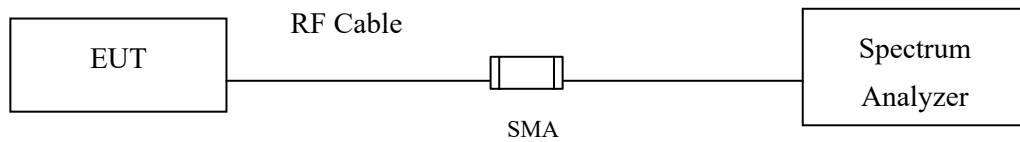

9.2. Test Procedure

The EUT was setup according to ANSI C63.10 2013; tested according to DTS test procedure of KDB558074 for compliance to FCC 47CFR 15.247 requirements.

9.3. Uncertainty

$\pm 2.31\text{msec}$

9.4. Test Result of Duty Cycle

Product : Blood Glucose Monitoring System
 Test Item : Duty Cycle
 Test Mode : Mode 1: Transmit - BLE

Duty Cycle Formula:

$$\text{Duty Cycle} = \text{Ton} / (\text{Ton} + \text{Toff})$$

$$\text{Duty Factor} = 10 \text{ Log} (1/\text{Duty Cycle})$$

Results:

2.4GHz band	Ton (ms)	Ton + Toff (ms)	Duty Cycle (%)	Duty Factor (dB)
BLE	88.1160	88.1160	100.00	0.00

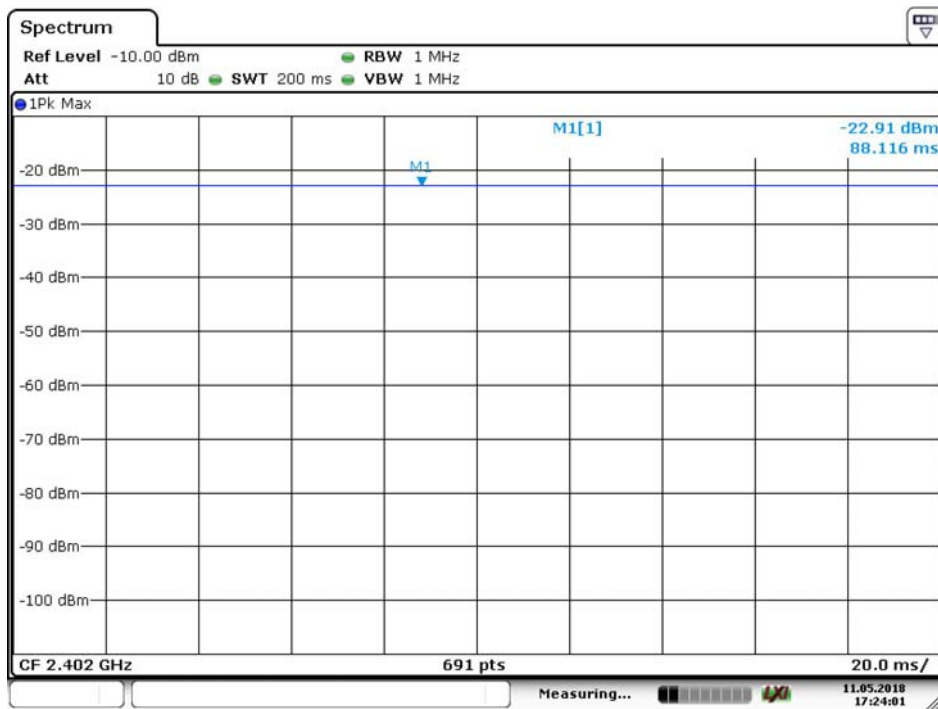

Date: 11.MAY.2018 17:24:01

10. EMI Reduction Method During Compliance Testing

No modification was made during testing.