

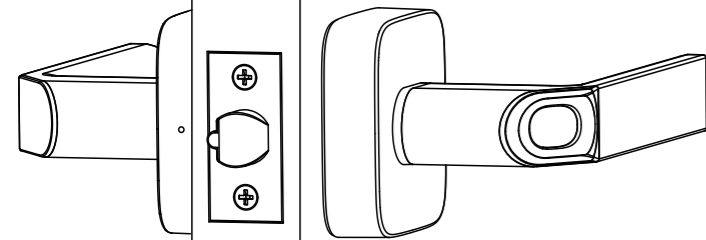

Ultraloq UL1 Smart Lock

Installation Guide (V1.0)



ultralq

What's in the Box

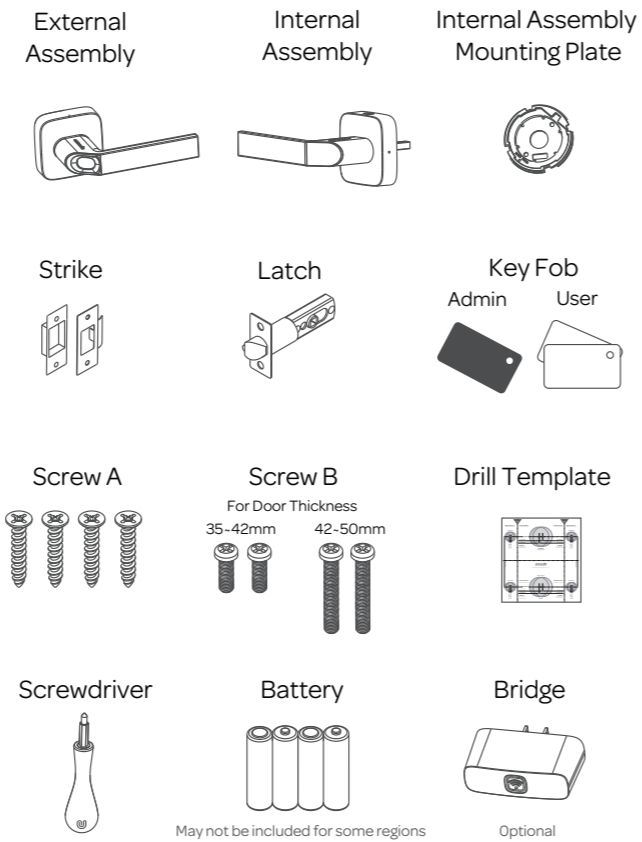

- 2 -

STEP 1

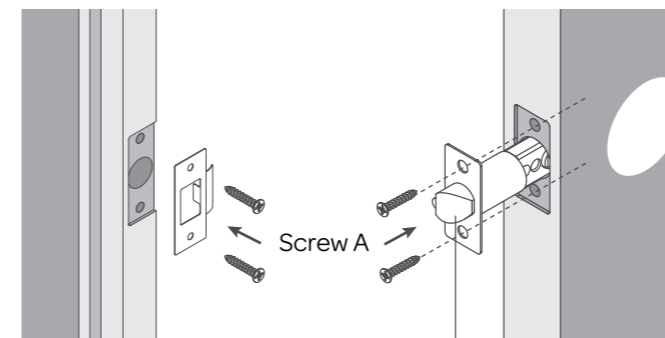

1. Insert Latch and Strike. Please align the Latch with the door's edge.
2. Tighten 2 Screw A on each side to fix the position.

Angle faces jamb

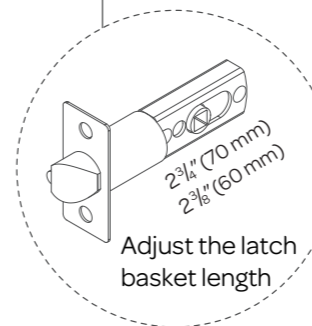

Adjust the latch basket length

- 5 -

STEP 2

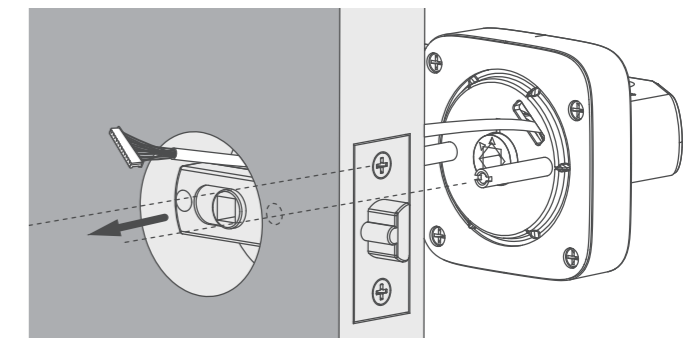

1. Install External Assembly. Align its two sticks with two holes on the latch.

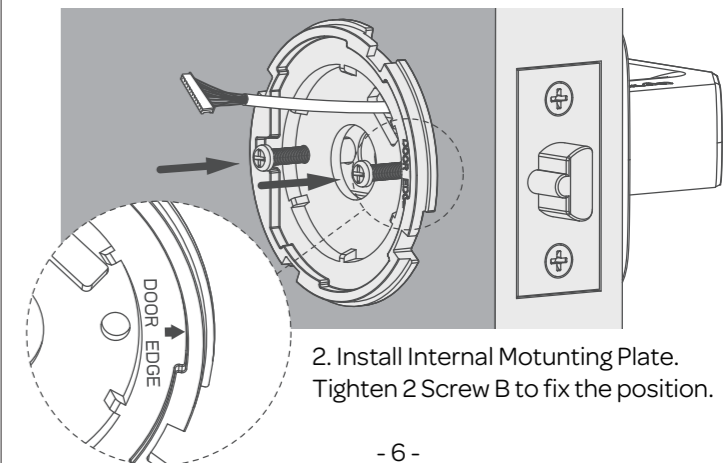

2. Install Internal Mounting Plate. Tighten 2 Screw B to fix the position.

- 6 -

Installation Video



<https://www.u-tec.com/installation/ul1>

Scan QR code to watch the installation video guide

Notes

- Install and test the lock with door open to avoid being locked out.
- Please follow the instruction in order.
- Need Help? Please contact customer support before returning the product.
- Visit www.u-tec.com/support
- Email support@u-tec.com

- 3 -

Preparing Door

Please check the door's dimensions.

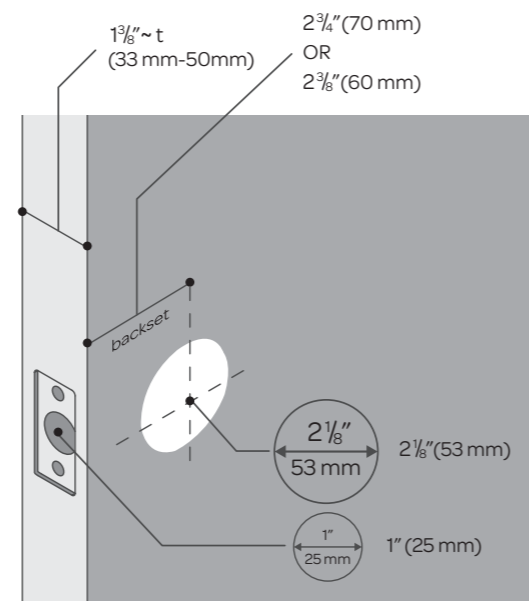

- 4 -

STEP 3

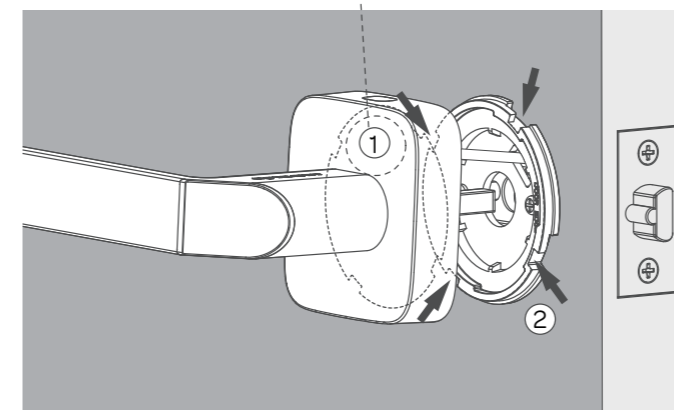
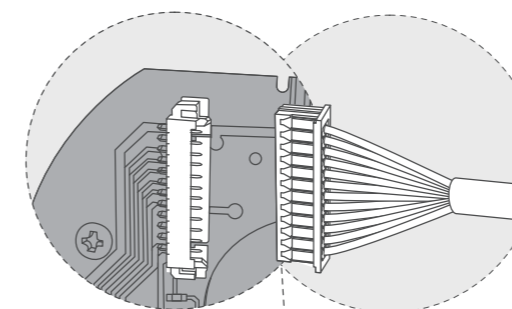

1. On Internal Assembly, connect the wire to the receiver. Insert the spindle into the hole.
2. Match and connect the gaps on Internal Mounting Plate and Internal Assembly.

- 7 -

STEP 4

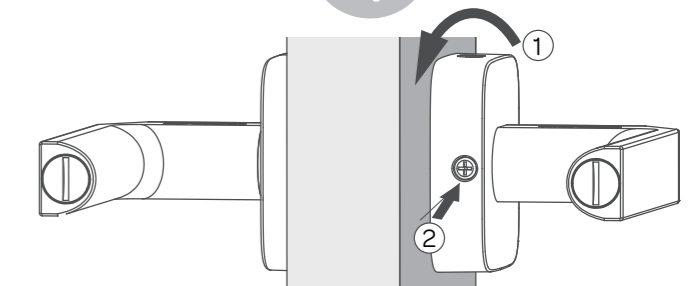

1. Turn Internal Assembly to the horizontal level.
2. Tighten the screw.

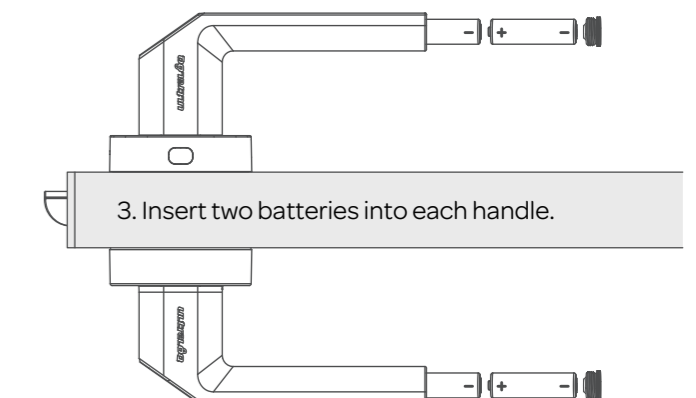

3. Insert two batteries into each handle.

Touch the fingerprint sensor to activate it. LED will blink blue. At this stage, any fingerprint will open the lock. Please go to the User Guide to set up the lock function.

- 8 -



Ultraloq UL1 Smart Lock

User Guide (V1.0)

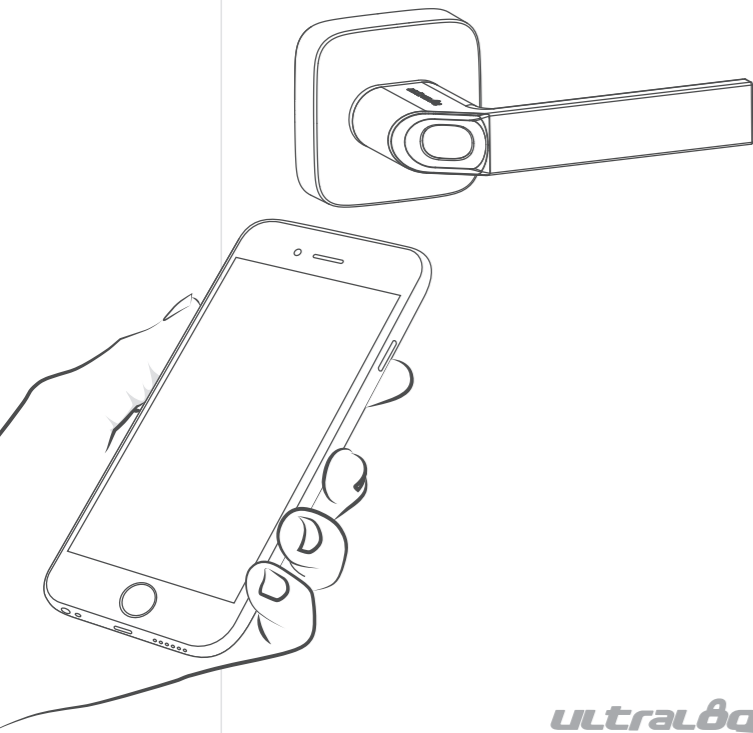

ultralq

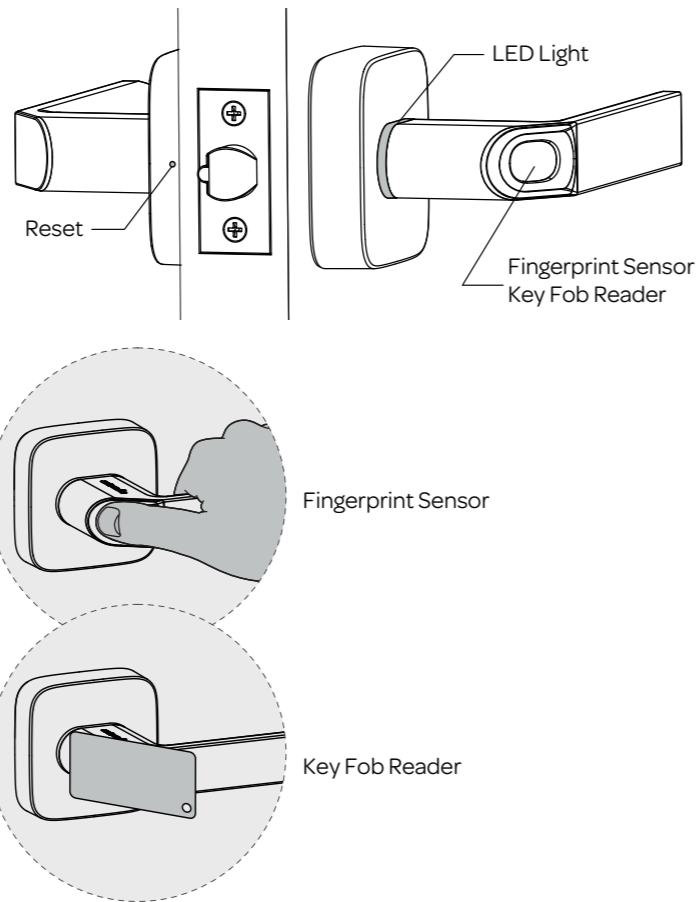

- 2 -

Use UL1 without Smartphone

- 1. Reset UL1 and Register Admin Key.**
 - 1) Pin the reset button for 3 seconds. LED will blink blue seconds.
 - 2) Tap the Black Key Fob (Admin Key) on reader. LED will flash green.
 - 3) Tap the Black Key Fob again. LED will flash green.
 - 4) Now the Black Key Fob has been registered as the Admin Key.
 - 2. Enter Register Mode.**
 - 1) Tap the Admin Key. UL1 will enter register mode. LED will blink blue.
 - 2) Now you can register new users by fingerprint or key fob.
 - 3. Register a Fingerprint User.**
 - 1) Press the finger on the sensor. LED will flash green. Repeat the process for 3 times.
 - 2) Once the fingerprint has been successfully registered, LED will blink blue as waiting for the next action.
- Register a Key Fob User.**
- 1) Pick a regular key fob as the User Key.
 - 2) Tap it on the reader. LED will flash green. Repeat the process for 2 times.
 - 3) Once the key fob has been successfully registered, LED will blink blue as waiting for the next action.

- 5 -

Use UL1 without Smartphone

- 4. Exit Register Mode.**
When LED is blinking blue, tap the Admin Key or wait 10 seconds to exit the register mode. LED will turn off.
- Notes:**
- 1) Whenever LED flash red, it means a failure has occurred.
 - 2) If a failure has occurred, the current process will be reset. Start over the process.**
 - 3) UL1 can store 99 fingerprints & 99 key fobs.

- 6 -

Perform Better Fingerprint

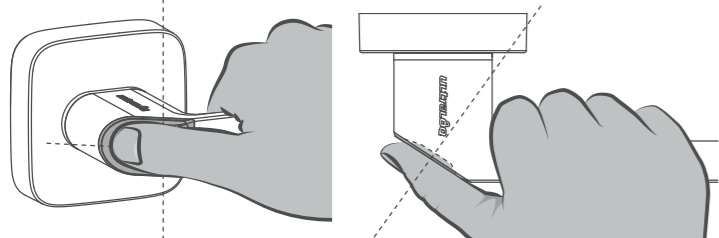

1. Follow the above illustration to register your fingerprint properly. Make sure your finger is flatly placed at the center of the reader for a better identification.
2. It is recommended that each user registers two or more fingerprints. When registering, place your finger at the center with the same gesture for three times.
3. Please note that dry, wet, oily or dirty fingers may affect the fingerprint identification.
4. Avoid the callus, peeling or injured finger to ensure the registration and identification successful.
5. In case of low recognition rate, please delete the original registered fingerprint and register it again.

- 3 -

Use UL1 with Smartphone



1. Scan the QR code to download the U-tec app, or search "U-tec" in App Store (iOS) and Google Play (Android).
 2. Open the app, register U-tec account, and log in the account.
 3. Reset UL1, turn on Bluetooth on the phone, stay near the lock, and search the lock in the app.
 4. Add the lock in the app and start to use it.
- * UL1 has another independent **Standalone Mode** that can be used without smartphone. Please check page 5 and page 6 for details.
- * UL1 has to be reset every time to switch between two modes.***
- * You can only use basic functions in Standalone Mode (Register and use fingerprint access & key fob access).

- 4 -

FAQ

- 1. What type of door does UL1 compatible with?**
UL1 is a latch lock that compatible with most of American doors (thickness 33-50mm). Please refer to Page 4 on Installation Guide for details.
UL1 cannot be installed on glass doors.
- 2. Does UL1 support left-handed/right-handed opening?**
Yes. When installing UL1, adjust its direction to your preference.
- 3. Installation completed, but there is no power on UL1.**
 - 1) Check the direction of the batteries. Positive pole should towards the latch.
 - 2) On Internal Assembly, Check if the wire is connected to the receiver correctly.
- 4. What's the difference between App Mode and Standalone Mode?**
App Mode:
Use U-tec App (iOS&Android) via Bluetooth to control lock (including register and use fingerprint access & key fob access, check activity log, set lock status, clone user information, etc). If you have a Ultraloq Bridge, you can control lock remotely.

Standalone Mode:
You can register and use fingerprint access & key fob access directly on the lock. No smartphone required and lock cannot be controlled remotely.

- 7 -



Warranty Statement

Please check www.u-tec.com for specific warranty details and limitations.

Need Help? Contact Customer Support.

- Visit www.u-tec.com/support
- Email support@u-tec.com

- 8 -

FCC ID: ZAJZ2-UL1

U-tec Group Inc.

Model name: Ultraloq Smart Lock

Model No.: UL1

This device complies with Part 15 of the FCC Rules.

Operation is subject to the following two conditions: (1) this device may not cause harmful interference, and (2) this device must accept any interference received, including interference that may cause undesired operation.

Changes or modifications not expressly approved by the party responsible for compliance could void the user's authority to operate the equipment.

Note: This equipment has been tested and found to comply with the limits for a Class B digital device, pursuant to part 15 of the FCC Rules. These limits are designed to provide reasonable protection against harmful interference in a residential installation. This equipment generates, uses and can radiate radio frequency energy and, if not installed and used in accordance with the instructions, may cause harmful interference to radio communications. However, there is no guarantee that interference will not occur in a particular installation. If this equipment does cause harmful interference to radio or television reception, which can be determined by turning the equipment off and on, the user is encouraged to try to correct the interference by one or more of the following measures:

- Reorient or relocate the receiving antenna.
- Increase the separation between the equipment and receiver.
- Connect the equipment into an outlet on a circuit different from that to which the receiver is connected.
- Consult the dealer or an experienced radio/TV technician for help.