



# SIM8918EA、SIM8918NA

## User Manual

LTE Wireless Data Module

### **SIMCom Wireless Solutions Limited**

SIMCom Headquarters Building, Building 3, No. 289 Linhong  
Road, Changning District, Shanghai P.R. China

Tel: 86-21-31575100

[support@simcom.com](mailto:support@simcom.com)

[www.simcom.com](http://www.simcom.com)

## GENERAL NOTES

SIMCOM OFFERS THIS INFORMATION AS A SERVICE TO ITS CUSTOMERS, TO SUPPORT APPLICATION AND ENGINEERING EFFORTS THAT USE THE PRODUCTS DESIGNED BY SIMCOM. THE INFORMATION PROVIDED IS BASED UPON REQUIREMENTS SPECIFICALLY PROVIDED TO SIMCOM BY THE CUSTOMERS. SIMCOM HAS NOT UNDERTAKEN ANY INDEPENDENT SEARCH FOR ADDITIONAL RELEVANT INFORMATION, INCLUDING ANY INFORMATION THAT MAY BE IN THE CUSTOMER'S POSSESSION. FURTHERMORE, SYSTEM VALIDATION OF THIS PRODUCT DESIGNED BY SIMCOM WITHIN A LARGER ELECTRONIC SYSTEM REMAINS THE RESPONSIBILITY OF THE CUSTOMER OR THE CUSTOMER'S SYSTEM INTEGRATOR. ALL SPECIFICATIONS SUPPLIED HEREIN ARE SUBJECT TO CHANGE.

## COPYRIGHT

THIS DOCUMENT CONTAINS PROPRIETARY TECHNICAL INFORMATION WHICH IS THE PROPERTY OF SIMCOM WIRELESS SOLUTIONS LIMITED. COPYING, TO OTHERS AND USING THIS DOCUMENT, ARE FORBIDDEN WITHOUT EXPRESS AUTHORITY BY SIMCOM. OFFENDERS ARE LIABLE TO THE PAYMENT OF INDEMNIFICATIONS. ALL RIGHTS RESERVED BY SIMCOM IN THE PROPRIETARY TECHNICAL INFORMATION, INCLUDING BUT NOT LIMITED TO REGISTRATION GRANTING OF A PATENT, A UTILITY MODEL OR DESIGN. ALL SPECIFICATION SUPPLIED HEREIN ARE SUBJECT TO CHANGE WITHOUT NOTICE AT ANY TIME.

### **SIMCom Wireless Solutions Limited**

SIMCom Headquarters Building, Building 3, No. 289 Linhong Road, Changning District, Shanghai P.R. China

Tel: +86 21 31575100

Email: [simcom@simcom.com](mailto:simcom@simcom.com)

### **For more information, please visit:**

[https://www.simcom.com/module/smart\\_modules.html](https://www.simcom.com/module/smart_modules.html)

### **For technical support, or to report documentation errors, please visit:**

<https://www.simcom.com/ask/> or email to: [support@simcom.com](mailto:support@simcom.com)

Copyright © 2021 SIMCom Wireless Solutions Limited All Rights Reserved.

# 1 Introduction

## 1.1 Product Outline

SIM8918x series module is a 4G Android smart module developing by the platform of Qualcomm QCM2290, a 64-bit applications processor with Arm Cortex-A53 quad-cores at 2.0GHz with 512KB L2 cache. SIM8918x series module has abundant multi-media functions, including the 1080P@30 fps video codec, the HD+ 720\*1680@60Hz displaying screen, two MIPI-CSI cameras, and the multi-channel analog and digital-audio input and output. SIM8918x series module supports multiple communication modes, including the GSM/GPRS/EDGE, the WCDMA/HSPA+, the LTE-FDD, and the LTE-TDD. It also supports the WiFi 802.11 a/b/g/n/ac, and the BT4.x short range communication. For the satellite positioning system, SIM8918x series module supports the GPS, the GLONASS, the BEIDOU, and the Galileo. In conclusion, SIM8918x series module is a highly integrated product, which is widely applying to intelligent terminal devices in the field of the Internet of Things (IOT).

Model Name: SIM8918EA, SIM8918E

Product Name: LTE Wireless Data Module

Brand name: SIMCom

## 1.2 Functional Overview

Feature	Description
<b>Processor</b>	64-bit Arm Cortex-A53 Quad-cores at 2.0GHz with 512KB L2 cache
<b>Memory</b>	1804MHz clock (2*16-bit) BUS LPDDR4x SDRAM design Built-in eMMC 5.1 Flash, 16GB eMMC + 2GB LPDDR4x Or 32GB eMMC+3GB LPDDR4x (option) Or 8GB eMMC + 1GB LPDDR3 (option)
<b>SD</b>	SDC2 external interface supports SD3.0 TF card (Maximum 256G), support hot plug detection
<b>Operation System</b>	Support Android 12/13
<b>System Upgrade</b>	Upgrade via USB interface, support forced download
<b>Power Supply</b>	Power Domain: 3.4V~4.4V, support single-cell lithium battery power supply.
<b>Charge</b>	Internal charger, supports high charging current up to 1.8A
<b>Display</b>	One 4-Lane MIPI_DSI interface, the highest resolution is 720*1680, HD+.
<b>Camera</b>	Two CSI MIPI configurable 4/4 or 4/2/1 D-PHY: 2.5 Gbps /channel

	<p>C-PHY: ~10 Gbps (3.42 Gbps/channel)          Single ISP: 13 MP 30 ZSL; dual ISP: 25 MP 30 ZSL          Real time sensor input resolution: 25MP or 13MP+13MP</p>
<b>Video Codec</b>	<p>Encode: 1080p30 8-bit HEVC(H.265),H.264          Decode: 1080p30 8-bit H.264, HEVC(H.265),VP9          Concurrency: 1080p30 decode + 720p 30 encode</p>
<b>Audio</b>	<p>1-Channel Digital Audio Interface I2S: Support Master- and Salve-Mode          3-Channel Analog Audio Input          Master Microphone MIC1: Differential Input          Headphone Microphone MIC2: Single-end Input          De-noise Microphone MIC3: Differential Input          4-Channel Digital Microphone Input          3-Channel Analog Audio Output          Headphone: Class AB Amplifier Stereo Output          Receiver: Class AB Amplifier Differential Output          Lineout: Class AB Amplifier Differential Output</p>
<b>Audio Codec</b>	<p>MP3, AAC, He-AAC v1, v2, FLAC,APE, ALAC, AIFF</p>
<b>Voice Codec</b>	<p>EVRS, EVRC, EVRC-B, and EVRC-WB          G.711 and G.729A/AB          GSM-FR, GSM-EFR, and GSM-HR          AMR-NB and AMR-WB</p>
<b>USB</b>	<p>Support USB 3.1, support USB2.0          Support USB Type-C Interface          Support OTG          USB_VBUS OTG Mode 5V Power Output (500mA Typical)</p>
<b>UART</b>	<p>Support up to 3 Serial Ports          A 2-Wire Serial Port for Debug          Two 4-Wire Serial Ports support hardware flow control, High-speed up to 4Mbps.</p>
<b>I2C</b>	<p>Support up to seven I2C for touch screen, camera, sensor and other peripherals</p>
<b>SPI</b>	<p>Support up to 2*SPI interfaces, support master mode, the highest rate 50MHz</p>
<b>UIM Card</b>	<p>Support Dual Card Dual Standby: 1.8V/3.0V Dual Voltage</p>
<b>Power Level</b>	<p>Class 4 (33dBm±2dB) for EGSM850          Class 4 (33dBm±2dB) for EGSM900          Class 1 (30dBm±2dB) for DCS1800          Class 1 (30dBm±2dB) for PCS1900          Class E2 (27dBm±3dB) for EGSM850 8-PSK          Class E2 (27dBm±3dB) for EGSM900 8-PSK          Class E2 (26dBm±3dB) for DCS1800 8-PSK          Class E2 (26dBm±3dB) for PCS1900 8-PSK          Class 3 (24dBm+1/-3dB) for WCDMA bands          Class 3 (23dBm±2dB) for LTE-FDD bands          Class 3 (23dBm±2dB) for LTE-TDD bands</p>

<b>LTE Features</b>	<p>Support 3GPP R10 CAT4 FDD and TDD</p> <p>Support 1.4 to 20 MHz RF Bandwidth</p> <p>Support Downstream 2x2 MIMO</p> <p>FDD: the maximum 150Mbps(DL) / the maximum 50Mbps(UL)</p> <p>TDD: the maximum 150Mbps(DL) / the maximum 35Mbps(UL)</p>
<b>UMTS Features</b>	<p>Support 3GPP R8 DC-HSDPA/HSPA+/HSDPA/HSUPA/WCDMA</p> <p>Support 16-QAM, 64-QAM and QPSK modulation</p> <p>DC-HSDPA: maximum 42Mbps(DL)</p> <p>HSUPA: maximum 5.76Mbps(UL)</p> <p>WCDMA: maximum 384Kbps(DL) / maximum 384bps(UL)</p>
<b>GSM Features</b>	<p>R99:</p> <p>CSD: 9.6Kbps, 14.4Kbps</p> <p>GPRS: Support GPRS Multi-Slot Level 33(Default 33)</p> <p>Coding format: CS-1, CS-2, CS-3, and CS-4</p> <p>Maximum 85.6Kbps(UL) / Maximum 107Kbps(DL)</p> <p>EDGE: Support EDGE Multi-Slot Level 33(Default 33)</p> <p>Support GMSK and 8-PSK modulation and coding Methods</p> <p>Downlink Coding Format: CS 1-4 and MCS 1-9</p> <p>Uplink Coding Format: CS 1-4 and MCS 1-9</p> <p>The maximum 236.8Kbps(UL) / The maximum 296Kbps(DL)</p>
<b>WLAN Features</b>	<p>2.4G/5G Dual Frequency Range, Support 802.11a/b/g/n/ac, Maximum 433Mbps</p> <p>Support the Wake-on-WLAN.</p> <p>Support the WAPI SMS4 hardware encryption.</p> <p>Support the AP mode and the STATION mode.</p> <p>Support the WIFI Direct.</p> <p>Support the 2.4G MCS 0~8 for HT20 and VHT20.</p> <p>Support the 2.4G MCS 0~7 for HT40 and VHT40.</p> <p>Support the 5G MCS 0~7 for HT20, HT40</p> <p>Support the 5G MCS 0~8 for VHT20.</p> <p>Support the 5G MCS 0~9 for VHT40 and VHT80.</p>
<b>BT Features</b>	<p>BT2.1+EDR /3.0 /4.2 LE/5.x</p>
<b>Satellite Positioning</b>	<p>GPS/GLONASS/BEIDOU/Galileo</p>
<b>Temperature</b>	<p>Operation Temperature: -35℃~ +75℃</p> <p>Extend Operation Temperature: -40℃ ~ +85℃ [1]</p> <p>Storage Temperature: -40℃~ +90℃</p>
<b>Physical Size</b>	<p>Size: 40.5(±0.2)*40.5(±0.2)*2.85(±0.2)mm</p>

# 2 Package Information

## 2.1 Hardware Block Diagram

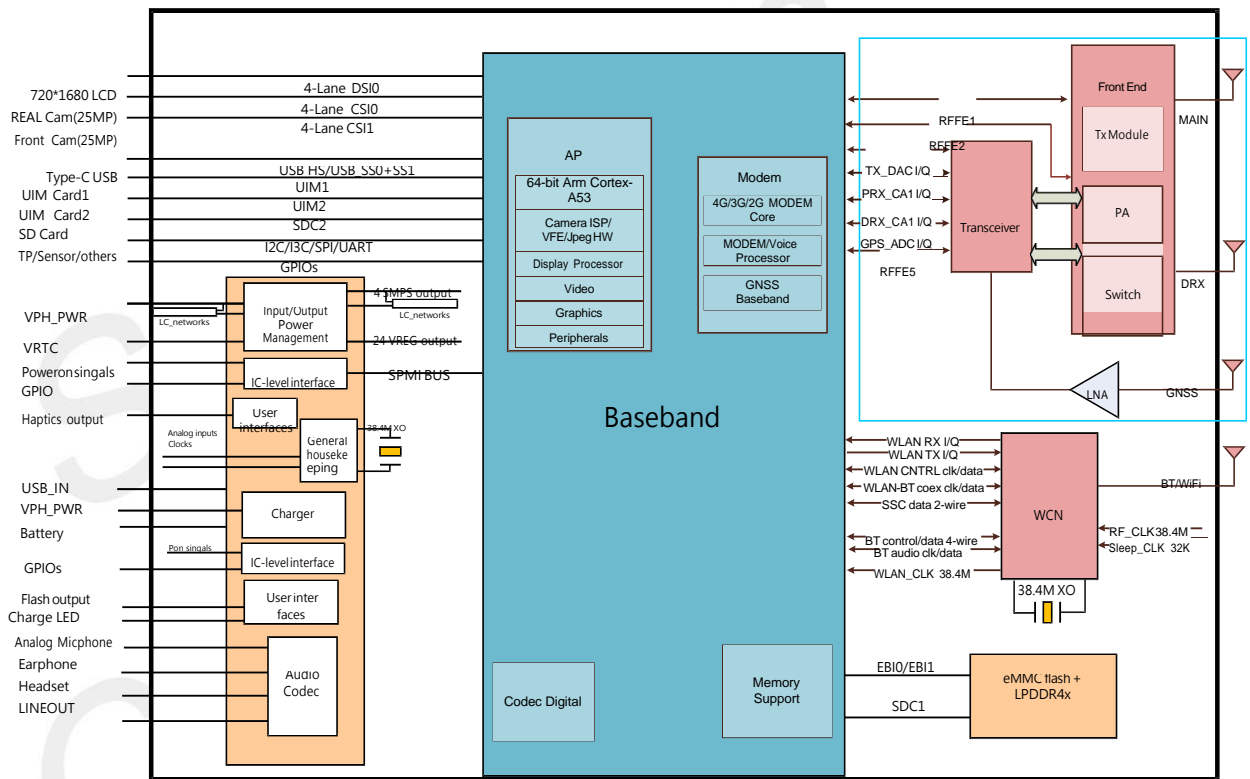

Figure 1: Module Block Diagram

## 2.2 Pin Assignment Overview

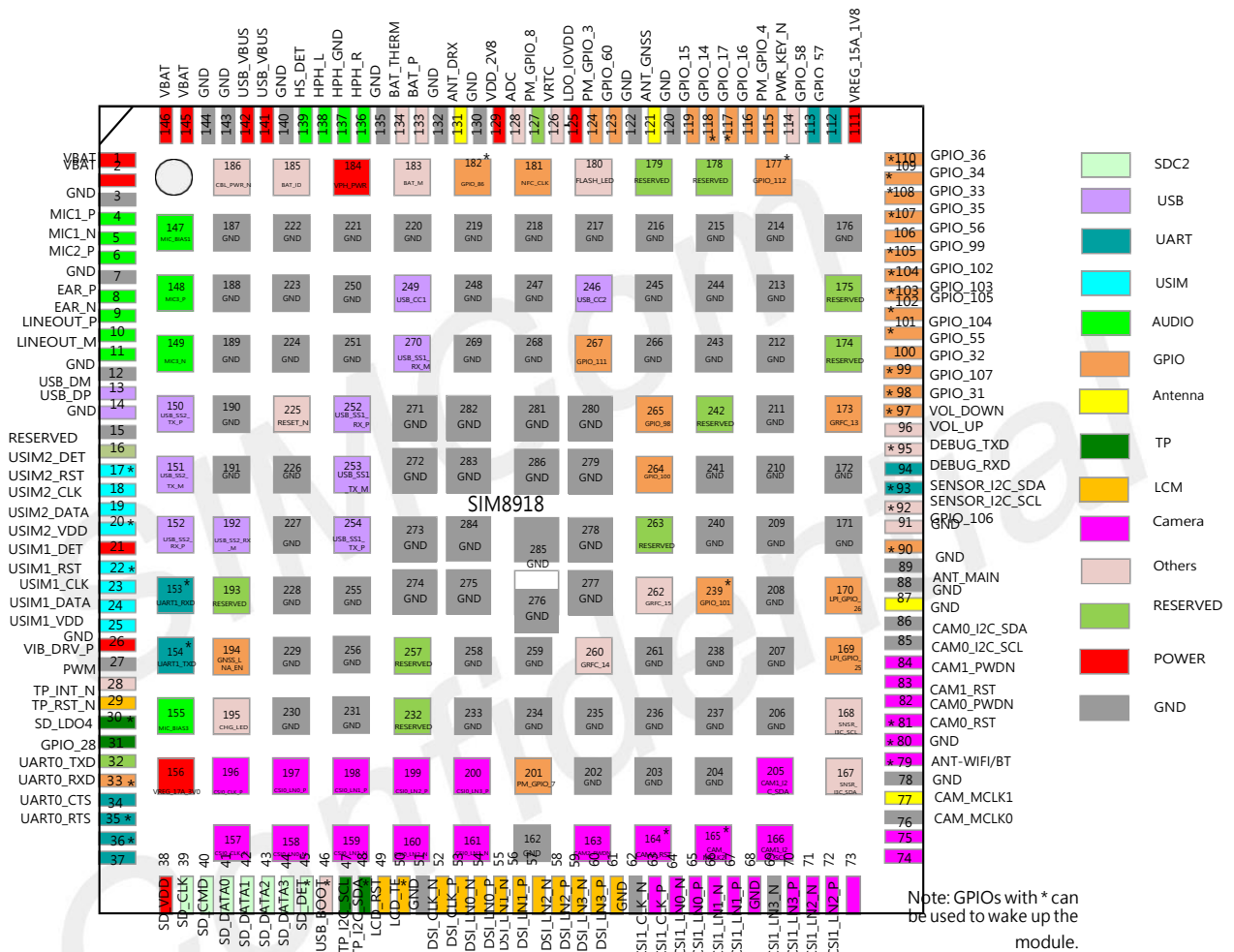

Figure 2: Pin Assignment Overview

### 2.3 Top- and Bottom-View of the Module



Figure 3: View of the Module



## 2.4 Mechanical Dimensional Size

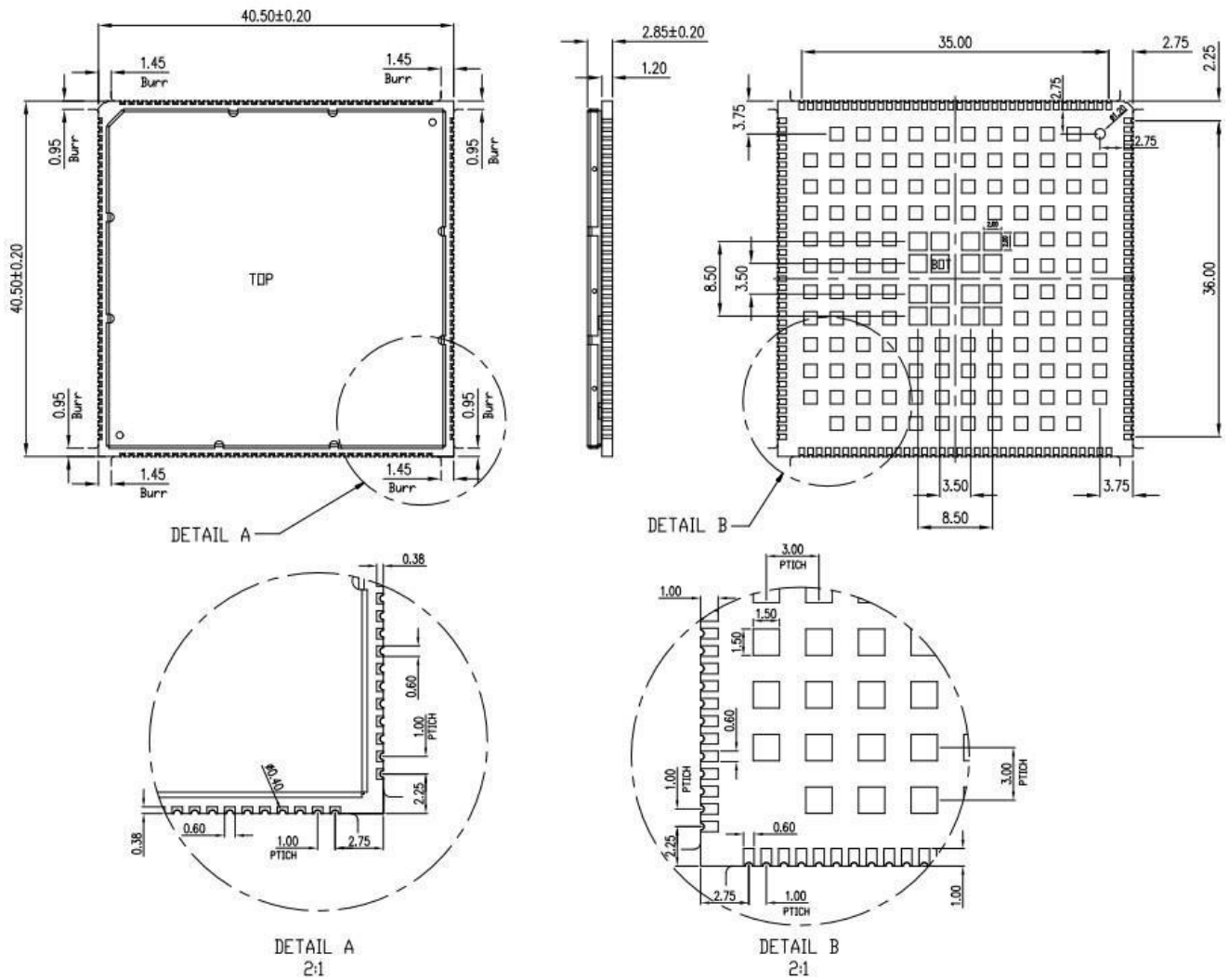

Figure 4: Three-Dimensional Size (Unit: mm)

## 3 Interface Applications

### 3.1 Power Supply

The SIM8918x module operating power (VBAT) is 3.4V to 4.4V, and the typical voltage is 3.9V. The instantaneous peak current of the SIM8918x module could reach 3A. So, to enable the module is running smoothly, the power supply should be able to provide the peak current up to 3A. If the power supply is designed improperly, there would be a large voltage drop on the VBAT. The shutdown voltage of the SIM8918x module is 3.2V. If the voltage drop on the VBAT is lower than 3.2V, the module would power off.

#### 3.1.1 Pin Overview

SIM8918x series module supports a single lithium battery power supply (4.2V or 4.35V battery cell). It also supports the other types of batteries. But the maximum voltage could not exceed the maximum allowance voltage of the module. Otherwise, the module would be burned. In terms of the non-battery power supply applications, the module would power by an LDO when the DC input is up to 5V. The reference design is showing in Figure 3.

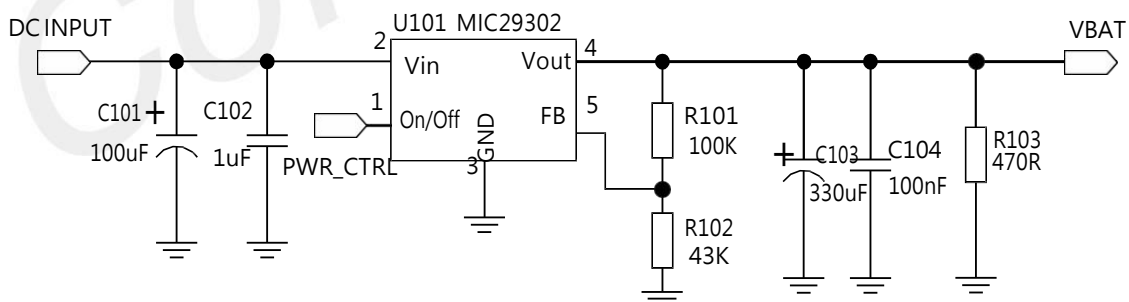

Figure 5: LDO Power Supply Reference Design

Highly recommend selecting a relative high efficiency switching power supply for hardware design when the difference between the input (DC Input) and the output (VBAT) is too large.

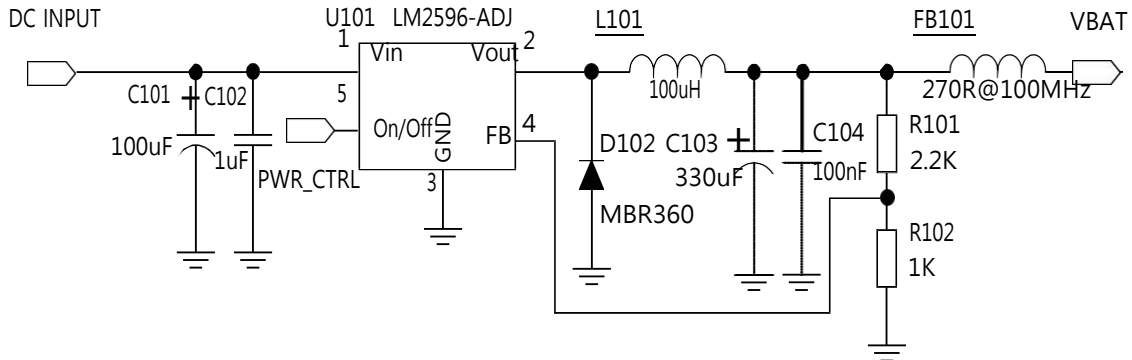

Figure 6: DC-DC Power Supply Reference Design

**NOTE**

1. Highly recommend disconnect the VBAT power supply to power off the module when the module is running abnormally. After that, restart the module by powering.
2. The module supports the charging function. There is a need to turn off the charging function in the software patch when the customers are using the power supply without the charging function. Or connect Schottky diodes in series on the VBAT channel to prevent the current anti-flowing into the chip.

### 3.1.2 Power Supply Stability Design

Highly recommend place bypass capacitors and voltage stabilizing components near the VBAT Pin to enhance the stability of the power supply. The reference design is showing in the Figure 5.

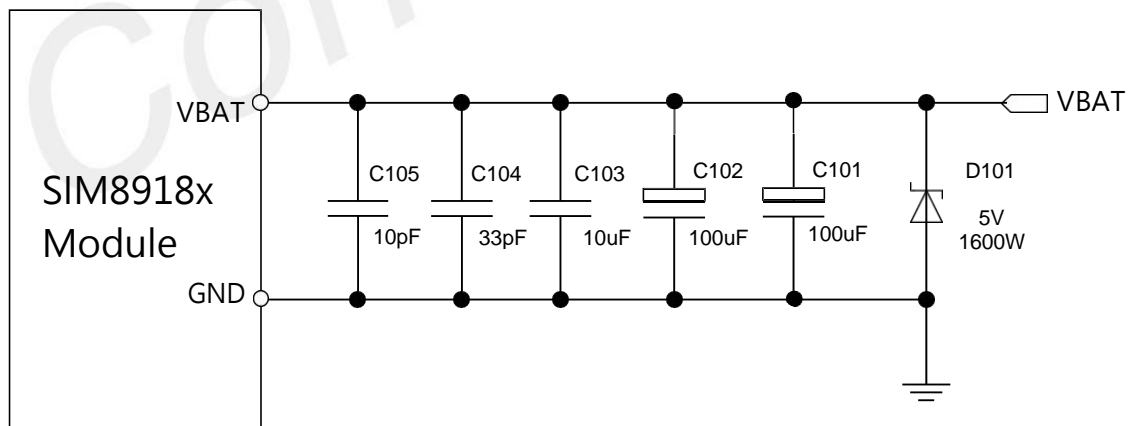

Figure 7: DC-DC Power Supply Reference Design

C101 and C102 are two Low-ESR 100uF tantalum capacitors. C103 is a 1uF to 10uF ceramic capacitor. The function of C104 and C105 is to decrease the high frequency interference. D101 is a 5V/1600W transient voltage suppression diode, preventing the chip from being damaged by surge. For PCB wiring, the capacitors and the diodes should be close to the VBAT Pin as far as possible, and the VBAT wiring should

be as short as possible with the width at least 3mm.

	Vendor	Manufacture Number	Power(Watts)	Package
1	PRISEMI	PTVSHC3N4V5B	2800W	DFN2020-3L
2	PRISEMI	PTVSHC2EN5VU	1600W	DFN1610-2L

### 3.2 Power On & Power Off

The on-off of the SIM8918x series module has two status, including the normal on-off and the abnormal on-off. In terms of the high- and low-pressure, and the high- and low-temperature, it should be working within the maximum power domain when running the module. Otherwise, exceeding the absolute maximum power domain would cause permanent damage to the module.

#### 3.2.1 Power On

PWR\_KEY\_N (114 Pin) defines as the boot-up key when the VBAT is powering on, and triggering PWR\_KEY\_N with at least 2s low-level pulse starts the module. KPD\_PWR\_N Pin has internal pull-up, and the typical high-level voltage is 1.2V. The reference design is showing as below.

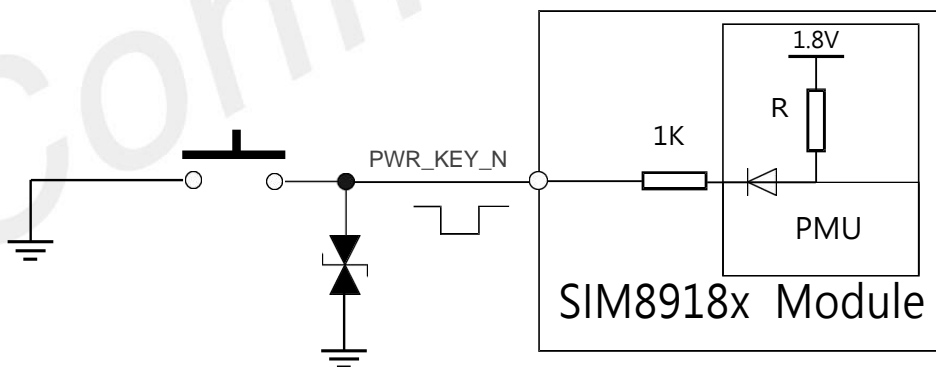

Figure 8: Power On/Off Design with a Key

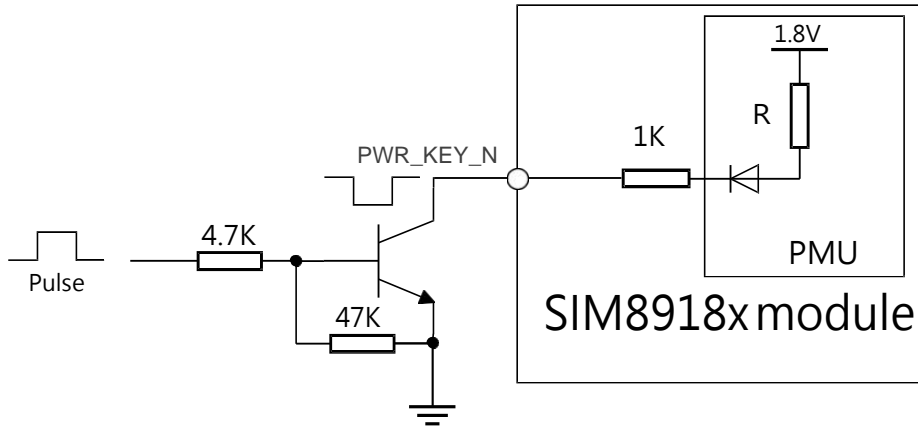

Figure 9: Power On/Off Design with an OC Gate

Highly recommend the customers consider the PWR\_KEY\_N Pin's electrical characteristics when designing. The electrical characteristics are showing in following:

Parameters	Description	Minimum	Typical	Maximum	Unit
V <sub>IH</sub>	High-Level Input Voltage	0.8	-	-	V
V <sub>IL</sub>	Low-Level Input Voltage	-	-	0.6	V

### 3.2.2 Power On Sequence

Figure shows the power on sequence of the module.

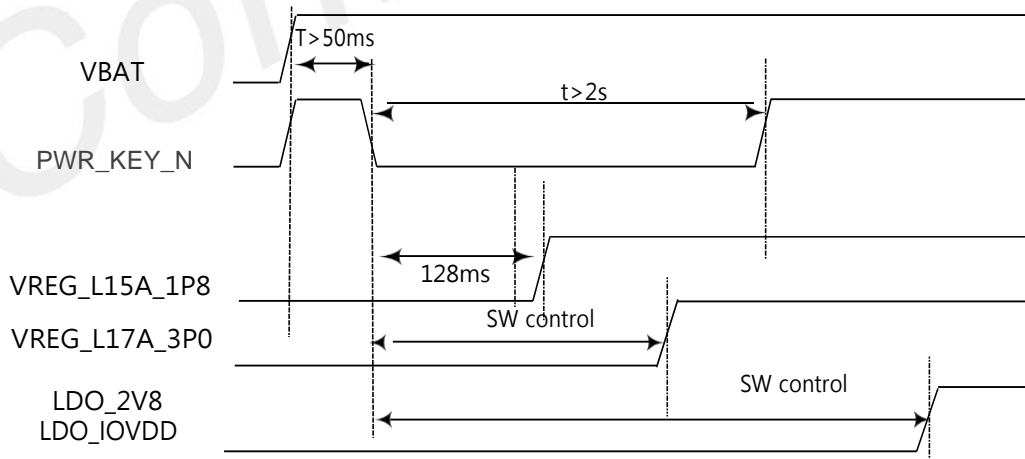

Figure 10: Power On/Off Design with an OC Gate

#### NOTE

Highly recommend pulling down the PWR\_KEY\_N Pin when booting up the VBAT voltage at 3.8V stabilizing for at least 50ms. Do not pull down the PWR\_KEY\_N Pin all the time.

### 3.2.3 Power Off

Pull down the PWR\_KEY\_N Pin with at least 1s to power off the module. There is a pop up prompt window confirming the action of shutting down the device when the module detects the control instructions. Apart from that, pulling down the PWR\_KEY\_N Pin with over 8s would be forced to restart the module.

Powering on and powering off are using the same pin, and they have the same reference design.

#### NOTE

1. The hardware design should cover the function of powering off the module. It is forbidden to run the module when powering off or restarting. Forced powering off the module adopts only when the module is running abnormally.
2. Highly recommend adding a low-cost MCU to control the PWR\_KEY\_N. Not only for the normal powering on and powering off but also for the watchdog function to protect the operation system.
3. Do not cut off the VBAT power supply directly when the module is running smoothly. It is to protect the internal flash memory.
4. Highly recommend to power off the module by the PWR\_KEY\_N Pin or the AT command before disconnecting the VBAT power supply.

## 3.3 VRTC

The VRTC is a standby power supply, connecting with a button battery or a large capacitor. VRTC would help to maintain the RTC timing when the VBAT is powering off. VRTC would also work as charging the button battery or a large capacitor when the VBAT is powering on.

- If the RTC fails, the RTC clock could be synchronized by connecting the data when the module is powering on.
- Please refer to the Table 10 for VRTC characteristics.
- The input power domain for the VRTC voltage supply is 2.0V to 3.25V. The typical voltage is 3.0V.

The average current consumption is 10uA when disconnecting the VBAT and connecting the RTC only.

- When powering on via the VBAT, the RTC working error is 50ppm. Switching the power supply mode of the VRTC Pin cause the RTC working error is 200ppm.
- Highly recommend the ESR of the button battery is less than 2K when connecting an external rechargeable button battery. Highly recommend to pick SEIKO's MS621FE FL11E.
- Highly recommend the ESR of the capacitor is 100uF when connecting an external large capacitor.

The reference designs for VRTC are showing below.

- **External Capacitor Power Supply for RTC**

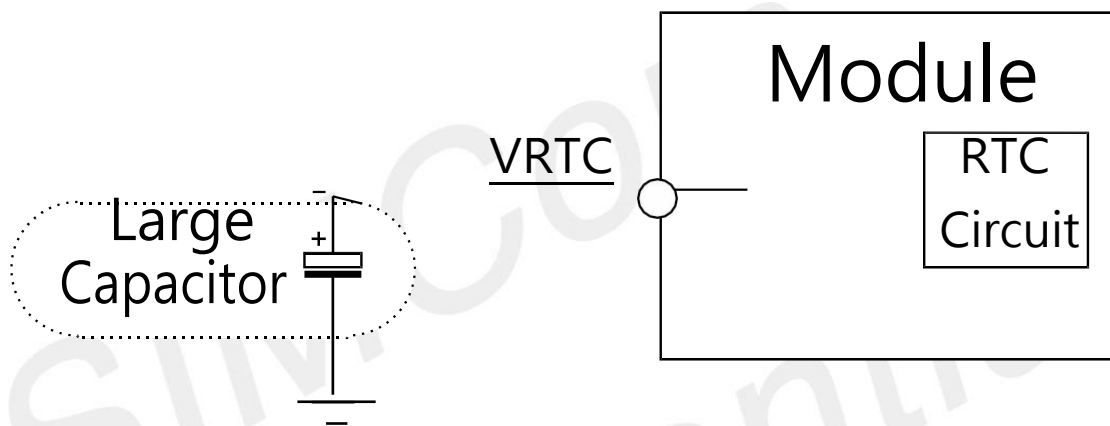

Figure 11: External Capacitor Power Supply for RTC

- **Non Rechargeable Battery Power Supply for RTC**

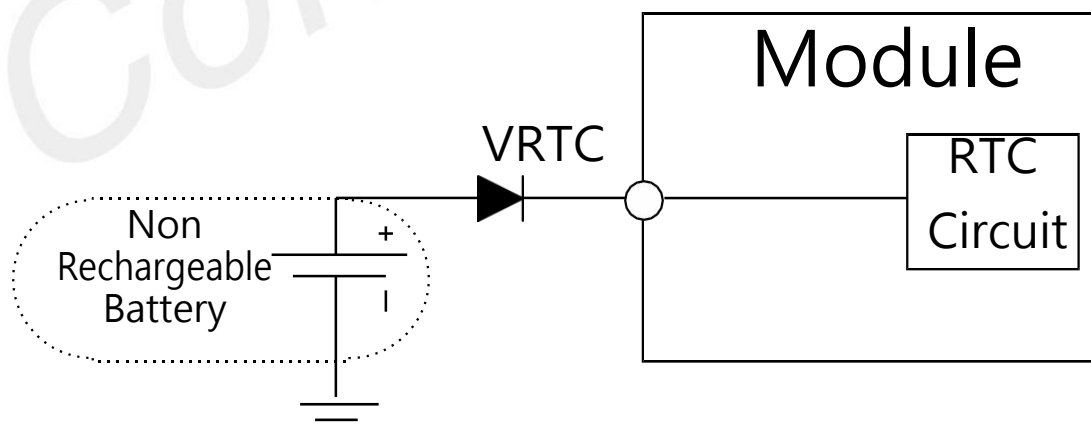

Figure 12: Non Rechargeable Battery Power Supply for RTC

- Rechargeable Battery Power Supply for RTC

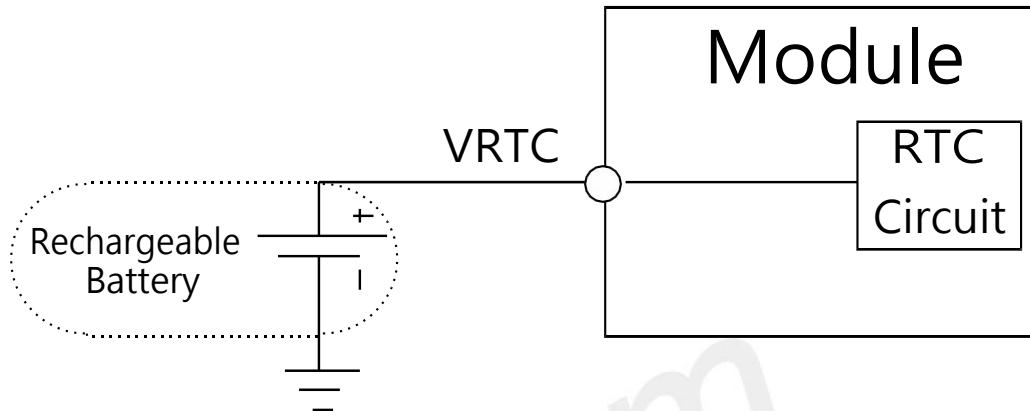

Figure 13: Rechargeable Battery Power Supply for RTC

The typical voltage of the VRTC is 3.0V. And the average current consumption is 20uA when disconnecting the VBAT and connecting the RTC only. The VRTC characteristics are showing in Table 13.

Parameters	Description	Minimum	Typical	Maximum	Unit
VRTC-IN	VRTC Input Voltage	2.0	3.0	3.25	V
T-series resistance	Standby Battery connecting in series resistor	800	-	2000	$\Omega$
I <sub>RTC-IN</sub>	VRTC Current Consumption (VBAT=0V)	-	10	-	$\mu$ A
Accuracy					
Power ON	Power ON	-	-	24	ppm
Power OFF	Power off (VBAT on)	-	-	50	ppm
	Power on (VBAT=0)	-	-	200	ppm

#### NOTE

- 1, If the VBAT is connecting an external non-removable rechargeable battery, float the VRTC Pin. Also, the software should be modified to turn off the VRTC charging instructions.
- 2, If the VBAT can be turn off and external Coin-cell battery doesn't use, it is recommended that a minimal 47uF capacitor add on VRTC pin.



### 3.4 Power Output

SIM8918x series module has 18 power outputs in total, which are suitable for a wide range of external interfaces and peripherals. Highly recommend a capacitor of 33pF and a capacitor of 10pF parallel connection to the ground, which could prevent high-frequency interference effectively.

Power Name	PIN Num	Output Voltage (V)	Rated Current (mA)	Default On	Description
VPH_PWR	184	3.4~4.4	2000	ON	Generated by either the charger or the battery
VREG_L15A_1P8	111	1.8	300	ON	External Power and External GPIO pull up and the 1.8V power level conversion
USIM1_VDD	26	1.8/2.95	150	Off	SIM Card1 Power
USIM2_VDD	21	1.8/2.95	150	Off	SIM Card2 Power
SD_LDO4	32	3.0	22	Off	SD Card pull-up Power
SD_VDD	38	3.0	800	Off	SD Card Power
VREG_L17A_3P0	129	3.0	200	Off	Power for sensor
LDO_IOVDD	125	1.8	300	ON	LCM DVDD or camera IOVDD
VDD_2V8	129	2.8	300	ON	Camera AVDD
MIC_BIAS1	147	1.6-2.85V	6	Off	Microphone Bias
MIC_BIAS3	155	1.8	6	Off	Microphone Bias

### 3.5 Charging and Battery Management

SIM8918x series module supports high charging current up to 1.8 A (100 mA step size). Supports trickle charge, pre-charge, constant current charging, and constant voltage charging. The module integrates the internal charging temperature rising control function. Decreasing the charging voltage and the charging current happens automatically when the temperature is too high.

SIM8918x series module could charge the battery. It supports several charging modes, including the trickle charging mode, the pre-charging mode, the constant current charging mode, and the other charging modes.

- The Trickle Charging Mode:  
The system is running into the trickle charging mode when the voltage of the battery is lower than

2.1V. In this case, a charging current of 100mA (typical) is applied.

- The Pre-charging Mode:  
The system is running into the pre-charging mode when the voltage of the battery is between 2.1V and 3.0V (The cut-off voltage is programmable between 2.4V and 3.0V, Default 3.0V). The charging current is about 300mA (The current is programmable between 100mA and 450mA, Default 300mA).
- The Constant Current Charging Mode:  
The system is running into the constant current charging mode when the voltage of the battery is between the cut-off voltage of the pre-charging mode and 4.2V (The voltage is programmable between 3.6V and 4.2V, Default 4.2V). The charging current is programmable between 0mA and 1800mA (The Default USB charging current is setting at 500mA in the software configuration).
- The Constant Voltage Charging Mode:  
The system is running into the constant voltage charging mode when the voltage of the battery is reaching at the predefined float voltage. The charging status would stop when the charging current is reaching at setting current.

PIN Name	PIN Num	I/O	Description	Note
VBAT	1			
	2	PI/	Module Power Input,	
	145	PO	Battery Charge Output	
	146			
BAT_ID	185	AI	Battery Detection	Don't be float. Highly recommend an external 100KR resistor connecting to the ground when no battery ID.
BAT_THERM	134	AI	Battery Thermal Detection	Don't be float. Connect to the battery NTC Resistor, Highly recommend an external 100KR resistor connecting to the ground when no battery.
BAT_P	133	AI	Battery Voltage Detection +	Connect to VBAT close to battery.
BAT_M	183	AI	Battery Voltage Detection -	Connect to GND close to battery.

SIM8918x series module has the function of battery detection. Generally, there is a BAT\_ID Pin in the battery. Highly recommend an external 100KR resistor (R2) connecting to the ground when the battery has no BAT\_ID. Avoid float.

SIM8918x series module has the function of battery temperature detection. This function requires an integrated thermistor in the battery (Recommend a 100KR  $\pm$  1% NTC Resistor). And the NTC resistor needs to connect to the BAT\_THERM Pin. The module would charge fail when floating the BAT\_THERM pin.

SIM8918x series module has the function of battery's fuel gauge. It estimates the real-time power of the battery accurately. Not only protect the battery and prevent the over dis-charge but also help the users to estimate the entertainment time and save the important data. For different types of batteries, modifying the software settings enables the designated battery working properly.

The BAT\_P Pin and the BAT\_M Pin must be connected whether the module is powering on by a battery or a stable power supply. The module would not work well if floating these two pins. These two pins are for battery voltage detection. Differential pair routing and stereo ground plane are needed.

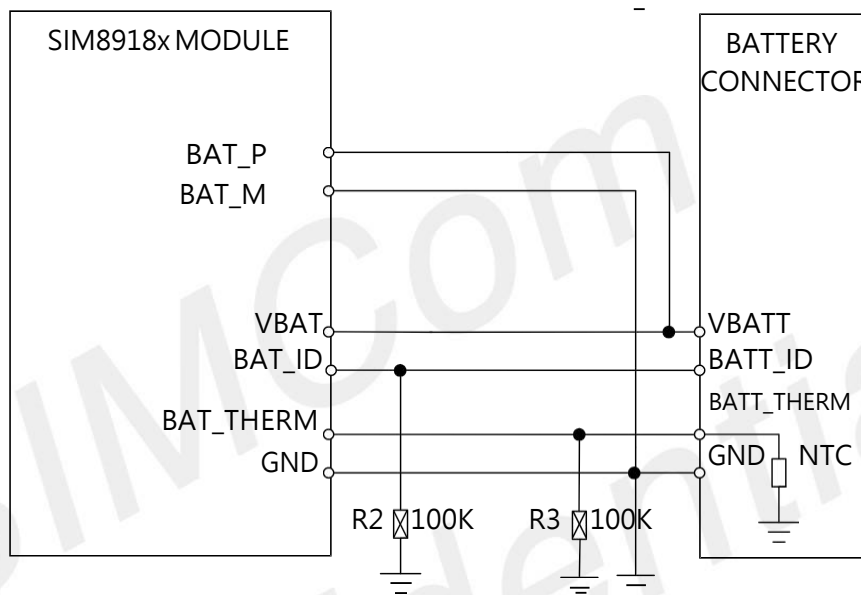

Figure 14: Battery Connection Reference Design

## 3.6 USB Interface

### 3.6.1 Micro-USB Interface and Type-C Interface

SIM8918x series module supports a USB interface, complying with USB 3.1/2.0 protocol and supporting USB OTG. The highest speed for the USB3.1 is up to 10Gbps, and for the USB 2.0 is up to 480Mbps. It is downward compatible with full speed (12Mbps) mode. USB\_HS interface supports the function of the AT command transmission, of the data transmission, of the software debugging, and of the software upgrading.

SIM8918x series module recommends Type-C USB. When used Micro-USB interface, the CC1 pin need to connect to the Micro USB connector's USB\_ID, and 10K pull-up resistor to VBUS.

- The Type-C Interface Reference Design

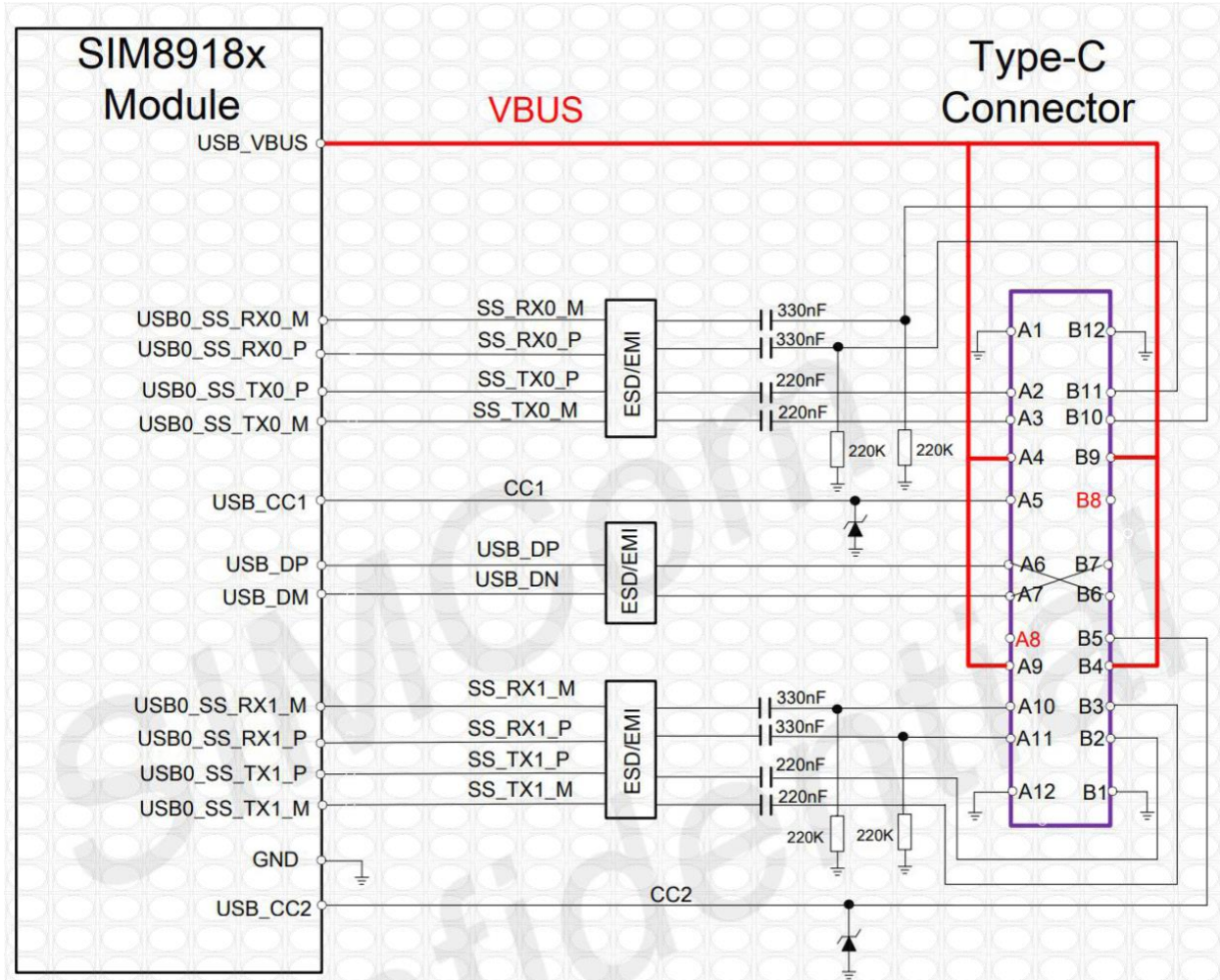

Figure 15: USB Type-C Connection Reference Design

- The Micro-USB Interface Reference Design

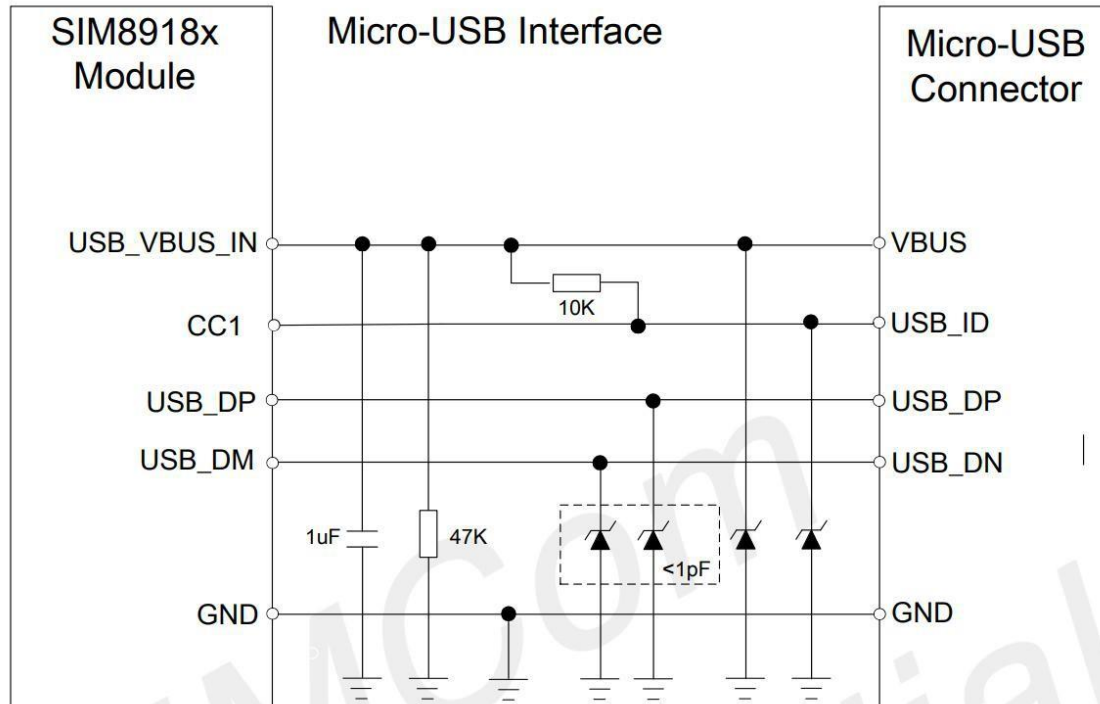

Figure 16: USB Micro-USB Connection Reference Design

### 3.6.2 Micro-USB Interface and Type-C Interface Feature

PIN Name	PIN Num	USB Mode
USB_SS1_RX_P/M	252/270	USB_SS1_RX_P/M
USB_SS1_TX_P/M	254/253	USB_SS1_TX_P/M
USB_SS2_RX_P/M	152/192	USB_SS2_RX_P/M
USB_SS2_TX_P/M	150/151	USB_SS2_TX_P/M
USB_DP/M	13/14	USB_DP/M
USB_CC1/USB_CC2	249/246	CC
USB_VBUS	141/142	VBUS

PCB wiring protocols and hardware design notices for USB signals are listing below.

- Differential pair routing, 90+/-10% differential impedance, and stereo ground plane are needed.
- Reserved ESD protection components close to the USB interface:  
Highly recommend the TVS junction capacitance value on the USB2.0 signal lines less than 2pF.  
Highly recommend the TVS junction capacitance value on the USB3.1 signal lines less than 0.5pF.
- Do not wiring the USB signals under the crystal oscillator, the oscillator, the magnetic devices, and the RF signals. Highly recommend routing in the inner layer and stereo ground plane.
- Highly recommend the USB2.0 signals, the USB3.1 TX signals, and the USB 3.1 RX signals are wiring as differential pairs separately.

### 3.7 UART/SPI/I2C/I2S Interface

SIM8918x series module supports multiple sets of the UART, the I2C, the SPI, and the I2S. The combination of multiple interfaces is flexible and achievable by the configuration of GPIOs. The interface voltage is 1.8V.

#### 3.7.1 UART/SPI/I2C Interface Multiplexing

Set	PIN Name	PIN Num	GPIO	Multiplex1 SPI	Multiplex2 UART	Multiplex3 I2C/I3C
1	UART0_CTS	36	GPIO_1	SPI1_MISO	UART0_CTS	I2C1_SDA/I3C1_SDA
	UART0_RTS	37	GPIO_2	SPI1_MOSI	UART0_RTS	I2C1_SCL/I3C1_SCL
	UART0_TX	34	GPIO_3	SPI1_CLK	UART0_TX	
	UART0_RX	35	GPIO_4	SPI1_CS_N	UART0_RX	
2	CAM0_PWDN	80	GPIO_8	APPS_I2C_SDA		
	CAM1_PWDN	82	GPIO_9	APPS_I2C_SCL		
2	TP_I2C_SDA	48	GPIO_6			TP_I2C_SDA
	TP_I2C_SCL	47	GPIO_7			TP_I2C_SCL
3	DEBUG_TXD	94	GPIO_12		DEBUG_UART_TXD	
	DEBUG_RXD	93	GPIO_13		DEBUG_UART_RXD	
4	GPIO_14	118	GPIO_14	SPI2_MISO	UART3_CTS	I2C4_SDA
	GPIO_15	119	GPIO_15	SPI2_MOSI	UART3_RTS	I2C4_SCL
	GPIO_16	116	GPIO_16	SPI2_SCLK	UART3_TX	
	GPIO_17	117	GPIO_17	SPI2_CS_N	UART3_RX	

5	CAM0_I2C_SDA	84	GPIO_22			CAM0_I2C_SDA
	CAM0_I2C_SCL	83	GPIO_23			CAM0_I2C_SCL
6	CAM1_I2C_SDA	205	GPIO_29			CAM1_I2C_SDA
	CAM1_I2C_SCL	166	GPIO_30			CAM1_I2C_SCL
7	UART1_RXD	153	GPIO_70		UART1_RXD	
	UART1_TXD	154	GPIO_69		UART1_TXD	
8	GPIO_98	265	GPIO_98	DMIC1_CLK	LPI_MI2S0_CLK	
	GPIO_99	105	GPIO_99	DMIC1_DATA	LPI_MI2S0_WS	
	GPIO_100	264	GPIO_100	DMIC2_CLK	LPI_MI2S0_DATA0	
	GPIO_101	239	GPIO_101	DMIC2_DATA	LPI_MI2S0_DATA1	
9	GPIO_105	102	GPIO_105		LPI_MI2S1_DATA1	
	GPIO_104	101	GPIO_104		LPI_MI2S1_DATA0	
	GPIO_103	103	GPIO_103		LPI_MI2S1_WS	
	GPIO_102	104	GPIO_102		LPI_MI2S1_CLK	
10	SENSOR_I2C_SDA	92	GPIO_109			SENSOR_I2C_SDA
	SENSOR_I2C_SCL	91	GPIO_110			SENSOR_I2C_SCL
11	SNSR_I3C_SDA	167	LPI_GPIO_21			SNSR_I3C_SDA
	SNSR_I3C_SCL	168	LPI_GPIO_22			SNSR_I3C_SCL

- SIM8918x series module defines the default configuration for these pins highlighting in green. Please consult SIMCom staff to review the reference design and functions for these pins.
- SIM8918x series module supports 2 sets of SPI, 3 sets of UART, and 8 sets of I2C (including camera's I2C), 2 sets of I2S. Choosing only one function among the SPI, the UART, and the I2C in the same bus set. For example, the SPI2 and the UART2 could not function well at the same time.
- Highly recommend an external 2.2KΩ resistor pulling up to the 1.8V power supply for I2C.
- Do not reuse the Debug UART as GPIO12 and GPIO13.
- SPI interface could support the working frequency up to 50MHz.

### 3.7.2 UART Voltage Level Shift Circuit

SIM8918x series module supports up to 3 sets of the UART interfaces, including the 2 sets of the 4-Lane interface, and the Debug UART for debugging.

The two sets of the 4-Lane interface support the hardware flow control with the highest speed up to 4Mbps. The interface voltage for UART on the SIM8918x series module is 1.8V. Taking a voltage level shift chip for voltage switching if needed. Highly recommend pick TI's TXS0104EPWR, and the reference design is showing in the following Figures.

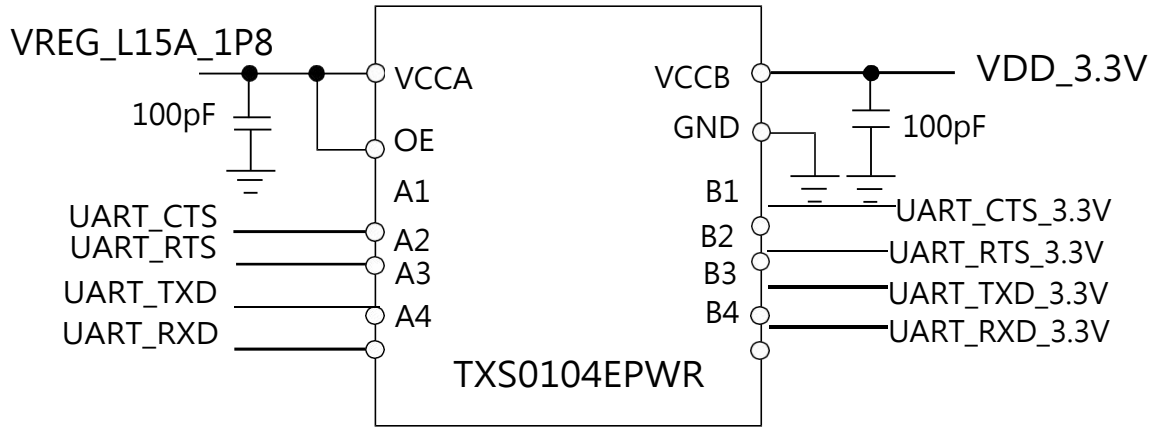

Figure 17: UART Voltage Level Shift Reference Design

The compatible reference design is showing below.

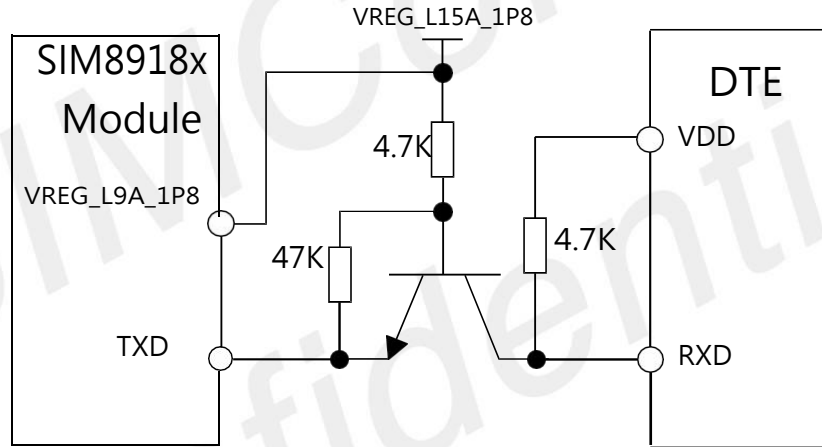

Figure 18: TX Voltage Level Shift Reference Design

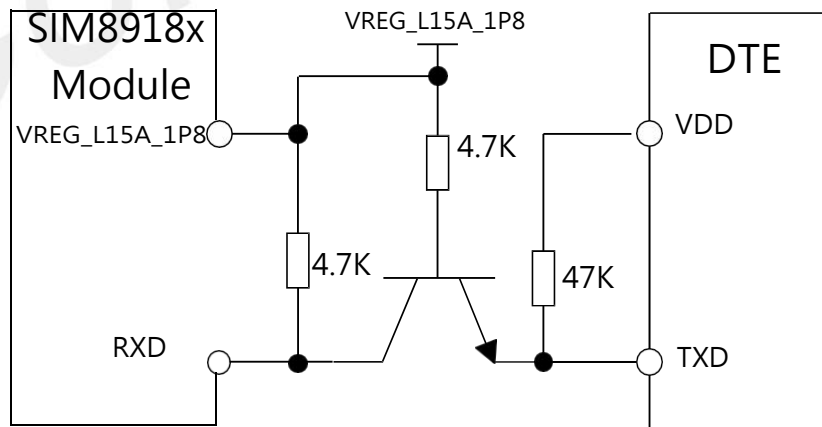

Figure 19: RX Voltage Level Shift Reference Design



### 3.7.3 SPI Interface

SIM8918x series module supports up to 2 sets of the SPI interfaces. They only support the host mode, and the highest working frequency is 50MHz.

PIN Name	PIN Num	I/O	Description	Notes
UART0_CTS	36	DI	SPI1_MISO	SPI Data Input Signal
UART0_RTS	37	DO	SPI1_MOSI	SPI Data Output Signal
UART0_TXD	34	DO	SPI1_SCLK	SPI Clock Signal
UART0_RXD	35	DO	SPI1_CS_N	SPI Chip Select Signal
GPIO_14	118	DO	SPI2_MISO	SPI Data Input Signal
GPIO_15	119	DO	SPI2_MOSI	SPI Data Output Signal
GPIO_16	116	DI	SPI2_SCLK	SPI Clock Signal
GPIO_17	117	DO	SPI2_CS_N	SPI Chip Select Signal

### 3.7.4 I2C Interface

SIM8918x series module supports up to 8 sets of the I2C interfaces, but only open the following 6 sets of the I2C interfaces by default. They only support the host mode, and the highest speed is 400Kbps.

Highly recommend an external 2.2KR resistor pulling up to the 1.8V power supply for I2C.

PIN Name	PIN Num	I/O	Pull Up Voltage	Description	Notes
TP_I2C_SDA	48	DI/DO	VREG_L15A_1P8	TP I2C Data Signal	For TP
TP_I2C_SCL	47	DO	VREG_L15A_1P8	TP I2C Clock Signal	
CAM0_I2C_SDA	84	DI/DO	CAMERA IOVDD	Camera I2C Data	For Cameras
CAM0_I2C_SCL	83	DO	CAMERA IOVDD	Camera I2C Clock	
CAM1_I2C_SDA	205	DI/DO	CAMERA IOVDD	Camera I2C Data	For Cameras
CAM1_I2C_SCL	166	DO	CAMERA IOVDD	Camera I2C Clock	
SENSOR_I2C_SDA	92	DI/DO	VREG_L15A_1P8	Sensor I2C Data	For Sensors
SENSOR_I2C_SCL	91	DO	VREG_L15A_1P8	Sensor I2C Clock	
SNSR_I3C_SDA	167	DI/DO	VREG_L15A_1P8	Sensor I3C Data	For Sensors
SNSR_I3C_SCL	168	DO	VREG_L15A_1P8	Sensor I3C Clock	

### 3.7.5 I2S Interface

SIM8918x series module supports 2 set of the I2S interfaces. It supports the input- mode, the output-mode, and the host-/device-mode.

PIN Name	PIN Num	Multiple I2S	I/O	Description
GPIO_98	265	LPI_MI2S0_CLK	DO	I2S0 Clock
GPIO_99	105	LPI_MI2S0_WS	DO	I2S0 Word Select
GPIO_100	264	LPI_MI2S0_DATA0	DI/DO	I2S0 Data0
GPIO_101	239	LPI_MI2S0_DATA1	DI/DO	I2S0 Data1
GPIO_102	104	LPI_MI2S1_CLK	DO	I2S1 Clock
GPIO_103	103	LPI_MI2S1_WS	DO	I2S1 Word Select
GPIO_104	101	LPI_MI2S1_DATA0	DI/DO	I2S1 Data0
GPIO_105	102	LPI_MI2S1_DATA1	DI/DO	I2S1 Data1

### 3.8 SD Card Interface

SIM8918x series module supports SD 3.0/MMC cards with 4-Bit data interface or SDIO 3.0 devices. The SD cards comply with the following protocols.

- SD Specifications Part 1 Physical Layer Specification Version 3.00
- Part A2 SD Host Controller Standard Specification Version 3.00
- Part E1 SDIO Specification Version 3.00

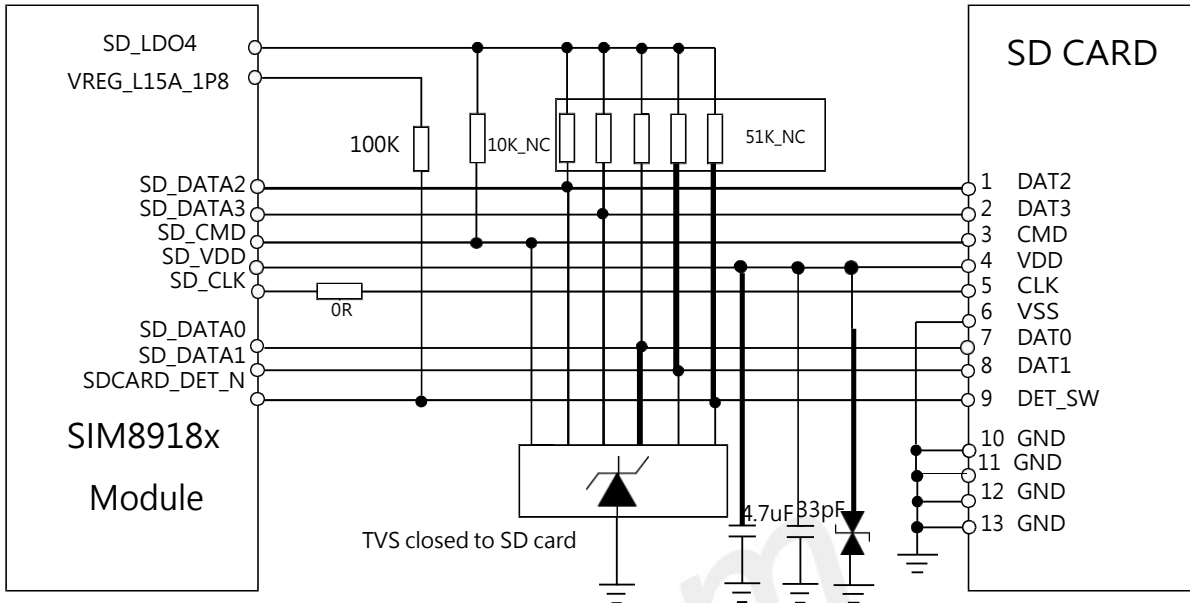

Figure 20: SD Card Reference Design

### 3.9 TP Interface

SIM8918x series module provides an I2C interface, an interruption function pin, and a reset pin, connecting the touching panel to operate.

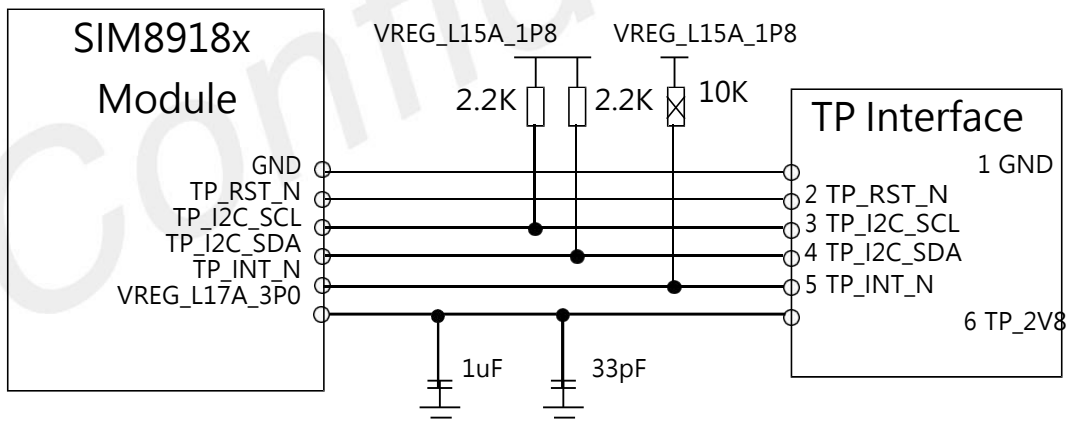

Figure 21: TP Interface Reference Design

#### NOTE

Highly recommend an external 2.2KR resistor pulling up to the 1.8V power supply for TP I2C.

### 3.10 LCD Interface

SIM8918x series module's video output interface meets the requirements of MIPI\_DSI standard. It has a 4-Lane DSI DPHY 1.2 interface with the speed up to 1.5Gbps. It supports screen display with the maximum resolution of 720\*1680 (HD+) at 60Hz.

The PWM pin of the module could control the backlight brightness by software configuration.

The MIPI signal lines are high-speed signal lines. Highly recommend place a common mode inductor close to the LCM to avoiding EMI interference. Float the MIPI\_Lane2 and the MIPI\_Lane3 when the LCM only has 2-Lane differential pair data signals. Highly recommend adopting the module's integrated reference circuits if the LCD interface has no bias voltage hardware design.

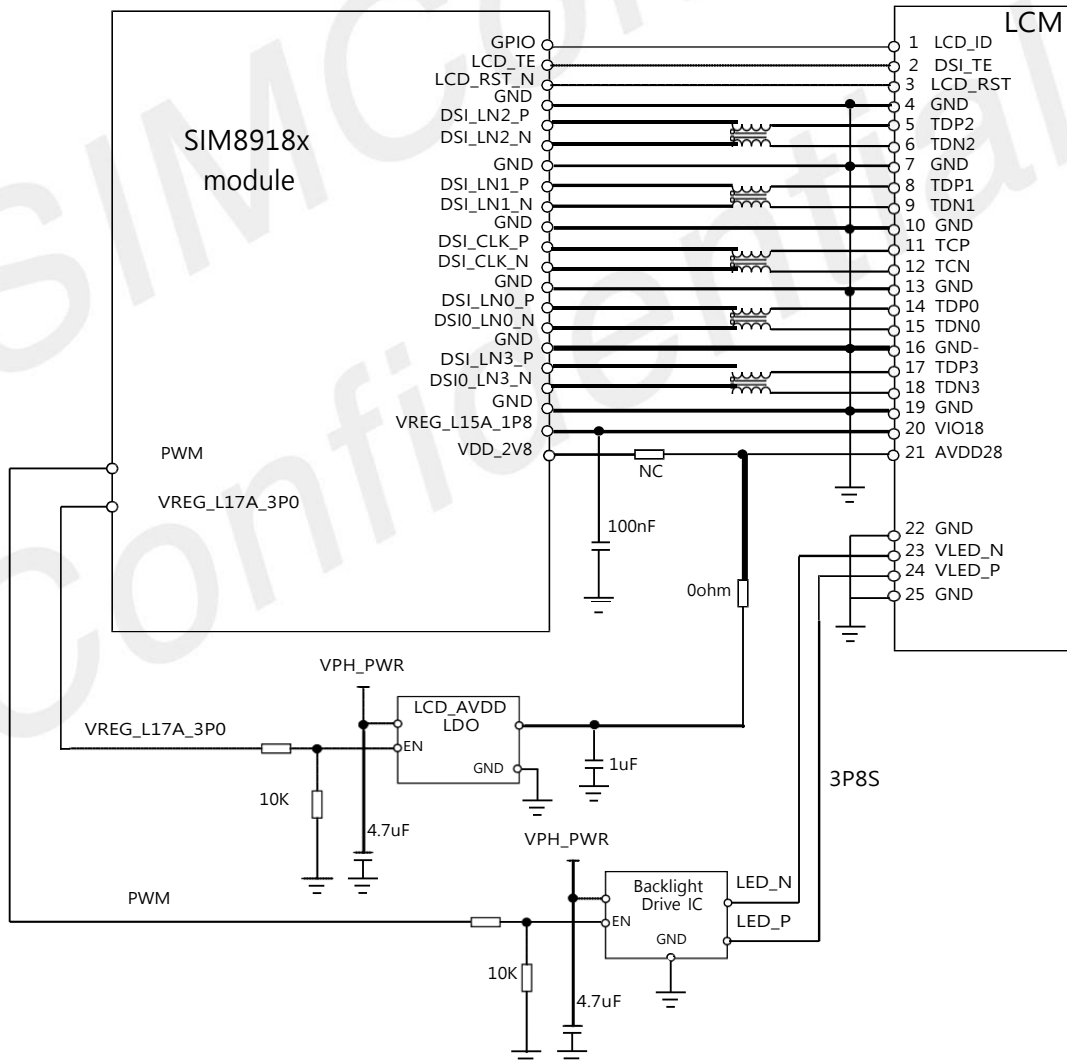

Figure 22: LCD Interface & the Backlight Reference Design

### 3.11 Camera Interface

SIM8918x series module's video input interface meets the requirements of MIPI\_CSI standard.

- 2 sets of 4-Lane CSI interfaces.  
Support 2 (4-Lane + 4-Lane ) cameras or  
Support 3 (4-Lane + 2-Lane + 1-Lane) cameras.
- Dual ISP support.  
Support DPHY 1.2 with the speed up to 1.5Gbps/Lane or support CPHY 1.0 with the speed up to 10.26Gbps(total).  
Two cameras: (13 MP + 13 MP or 25 MP) at 30 fps or (16 MP + 16 MP) at 24 fps, Only support one when the ISP is over 16M pixels.
- Support 3 MCLKs, 3 RESET, 2 CCI I2C interfaces, and the GPIOs with different functions.

#### 3.11.1 CPHY & DPHY Interface of the Cameras

SIM8918x series module supports CPHY 1.0. The difference between the CPHY and the DPHY are the different effective transmission mode. CPHY enables the data transmission speed faster through the following technical improvements. Firstly, CPHY converts the original 2-Lane group transmission of DPHY into 3-Lane group transmission. Then, CPHY does not need the Clock lane. The two are compatible in pin definitions.

CSIx PHY ( 1 of 2 )	DPHY	CPHY
Lane0	MIPI_CSIx_DCLK_P	NC
	MIPI_CSIx_DCLK_N	MIPI_CSIx_TLN0_A
Lane1	MIPI_CSIx_DLN0_P	MIPI_CSIx_TLN0_B
	MIPI_CSIx_DLN0_N	MIPI_CSIx_TLN0_C
Lane2	MIPI_CSIx_DLN1_P	MIPI_CSIx_TLN1_A
	MIPI_CSIx_DLN1_N	MIPI_CSIx_TLN1_B
Lane3	MIPI_CSIx_DLN2_P	MIPI_CSIx_TLN1_C
	MIPI_CSIx_DLN2_N	MIPI_CSIx_TLN2_A
Lane4	MIPI_CSIx_DLN3_P	MIPI_CSIx_TLN2_B
	MIPI_CSIx_DLN3_N	MIPI_CSIx_TLN2_C

Figure 21 shows the application diagram of the CSI interface. It is a combination configuration, including 2 DPHY sensors, 2 CPHY sensors, a DPHY sensor, and a CPHY sensor.. The following applications are flexible.

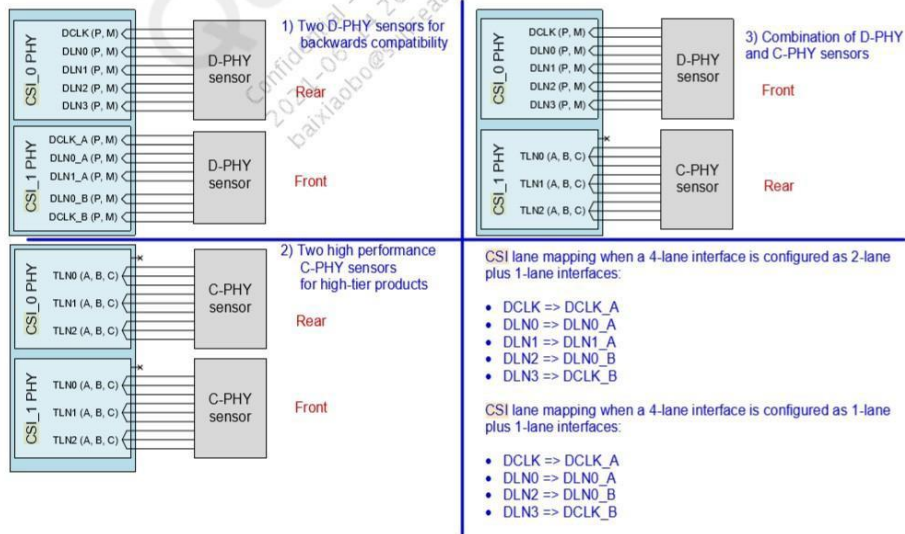

Figure 23: CPHY & DPHY Interface Applications

### 3.11.2 DPHY Applications

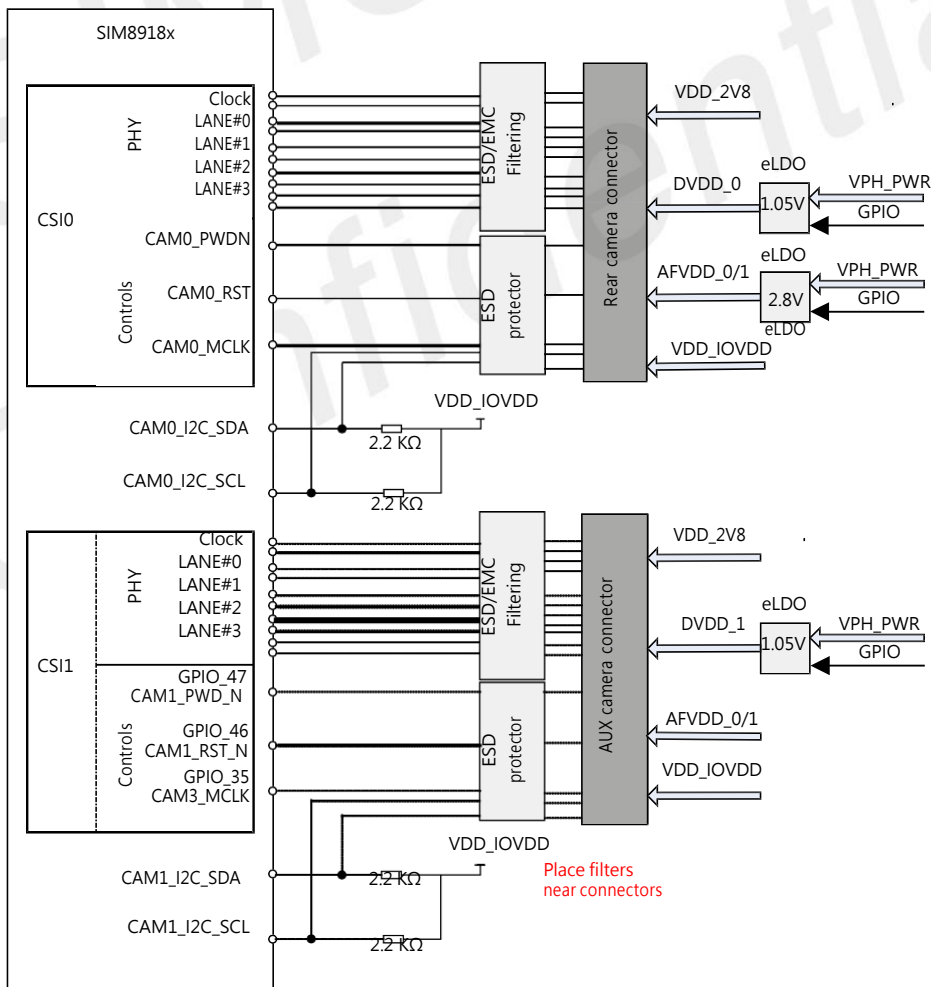

Figure 24: camera reference design

### 3.12 Audio Interface

SIM8918x series module supports following audio interfaces:

- Three analog audio inputs
  - MIC1 differential pair interface for the master microphone
  - MIC3 differential pair interface for the denoising microphone
  - MIC2 single ended interface for the audio jack.
- Three-Channel analog audio output interface.
  - Receiver
  - Lineout
  - Stereo Headphone
- Two-Channel digital microphone interface.
  - Support 4 digital microphones.

#### 3.12.1 Microphone Interface

ECM Type:

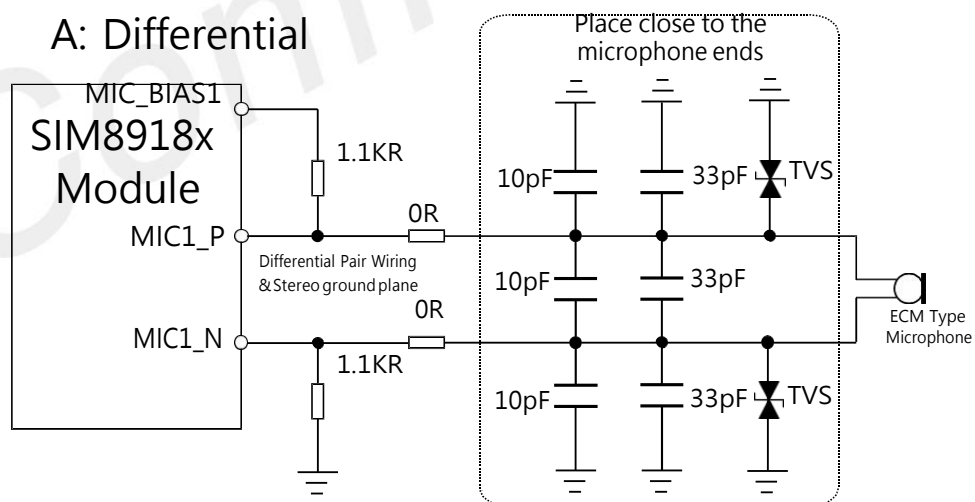

Figure 25: ECM Type Microphone Reference Design(Differential)

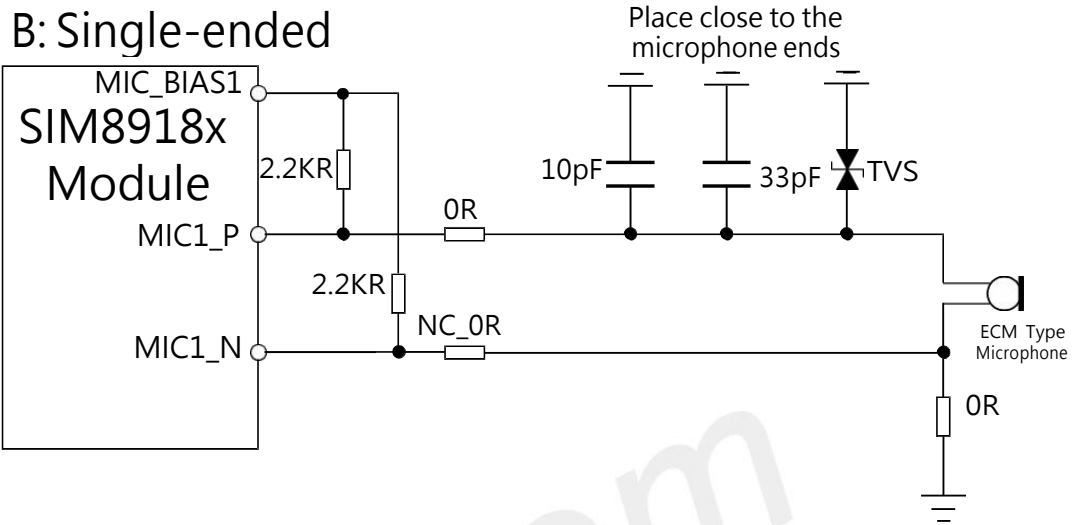

Figure 26: ECM Type Microphone Reference Design(single-ended)

MEMS Type:

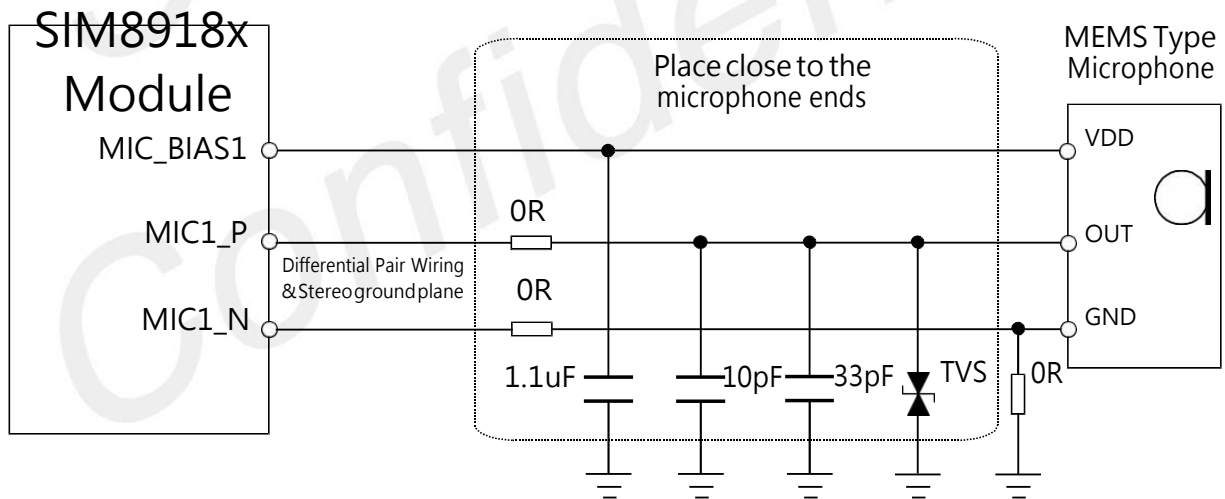

Figure 27: MEMS Type Microphone Reference Design



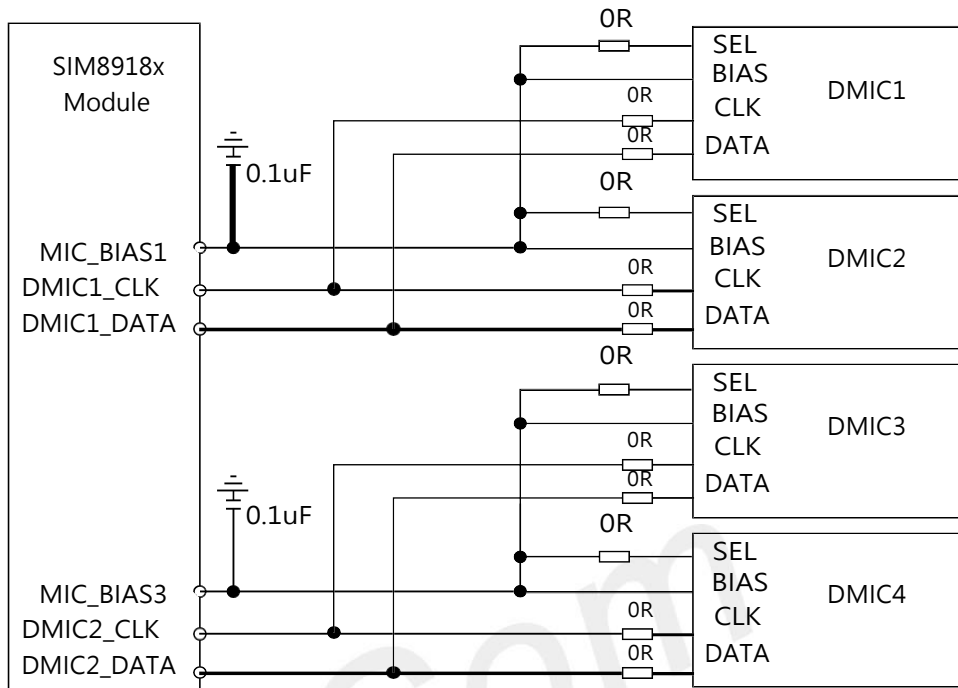

Figure 28: Digital Microphone Reference Design

### 3.12.2 Headphone Interface

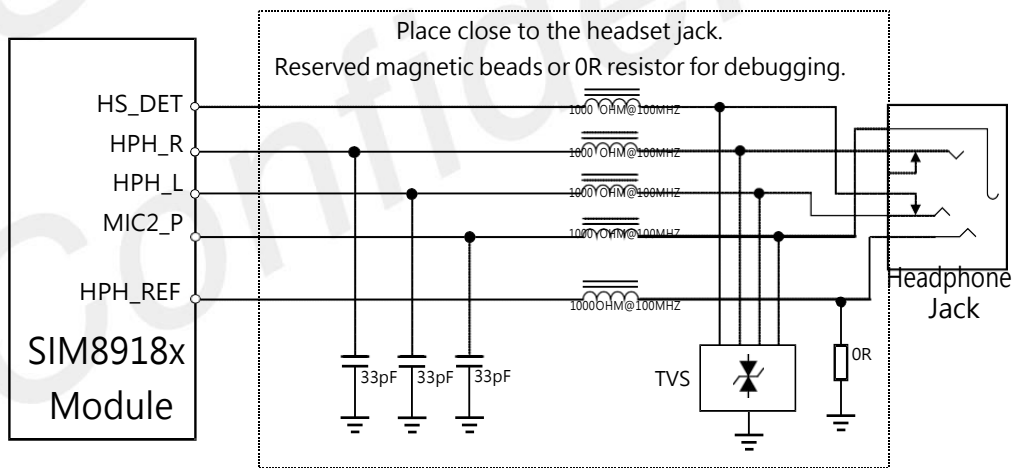

Figure 29: Headphone Reference Design

#### NOTE

1. Highly recommend the HS\_DET and the HPH\_L form a detection loop, and the HPH\_L has an internal 100KR resistor pulling down to the ground. The HS\_DET is connecting to the HPH\_L presenting actively low when disconnecting the headphone. The HS\_DET presenting high when inserting the headphone.
2. Picking a bidirectional TVS on the network due to the negative voltage on the HPH signal.

Parameter	Testing Condition	Minimum	Typical	Maximum	Unit
Output Power 1	Input = 0 dBFS, 32 Ω load.	-	31.25	-	mW
Output Power 2	Input = 0 dBFS, 16 Ω load.	-	62.5	-	mW
Output Voltage	Input = 0 dBFS	0.94	0.99	-	Vrms
Loads		-	16/32	-	Ω
Off Impedance		-	20	-	Ω

### 3.12.3 Lineout Interface

SIM8918x series module output Class-AB differential LINEOUT\_P/M. It can drive external speaker amplifier for loudspeaker.

- One differential class-AB amplifier
- 2Vrms ground reference differential output
- Programmable 0 dB or 6 dB gain
- Supports differential 1000ohm (minimum) and 300pF(typical ) load.

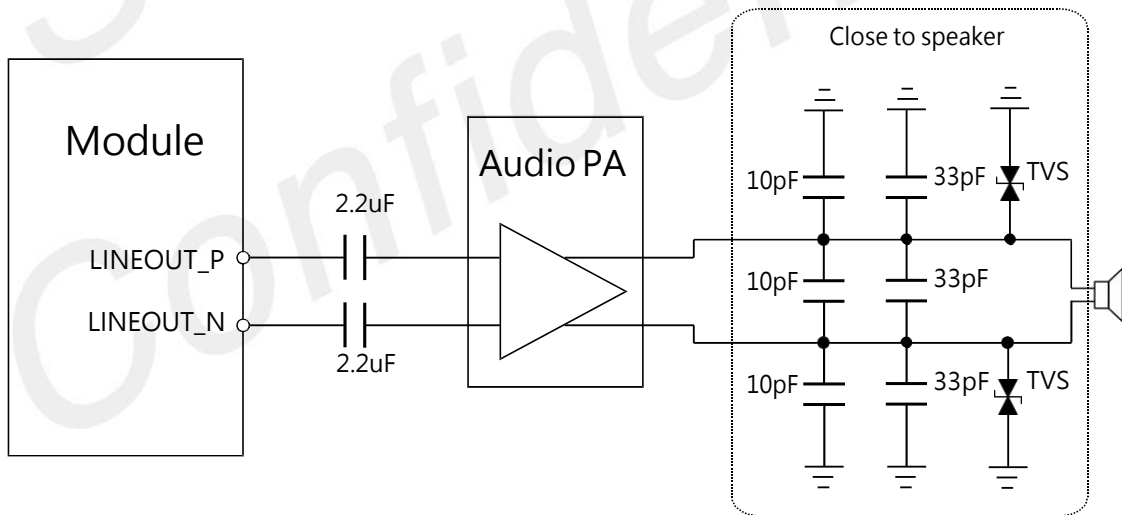

Figure 30: Speaker Reference Design

### 3.12.4 Handset Interface

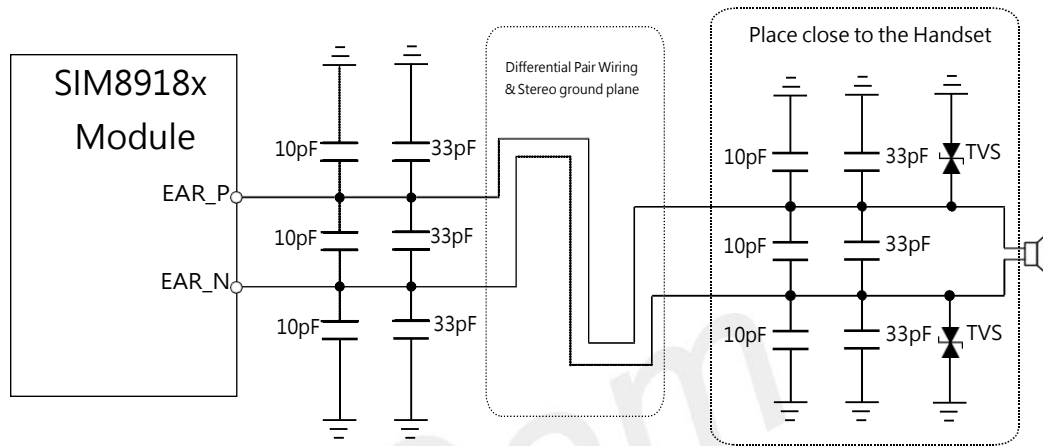

Figure 31: Handset Reference Design

Parameter	Testing Condition	Minimum	Typical	Maximum	Unit
Output Power	PA gain = 6 dB, 32 $\Omega$ , THD+N $\leq$ 1%	115	125	-	mW
	PA gain = 6 dB, 10.67 $\Omega$ , THD+N $\leq$ 1%	-	-	-	mW
Output Voltage	Input = 0 dBFS, PA gain = 6 dB	1.93	1.97	-	Vrms
Loads		10.67	32	-	$\Omega$

### 3.13 USIM Card Interface

SIM8918x series module offers two UIM Cards interface, supporting dual card dual standby. The UIM Cards interface also supports the 1.8V/2.95V dual voltage and the hot plug detection.

#### NOTE

The standard software version supports dual cards, and the single card function needs to be supported by the special software version.

The reference design for the UIM Card is showing in the Figure 30.

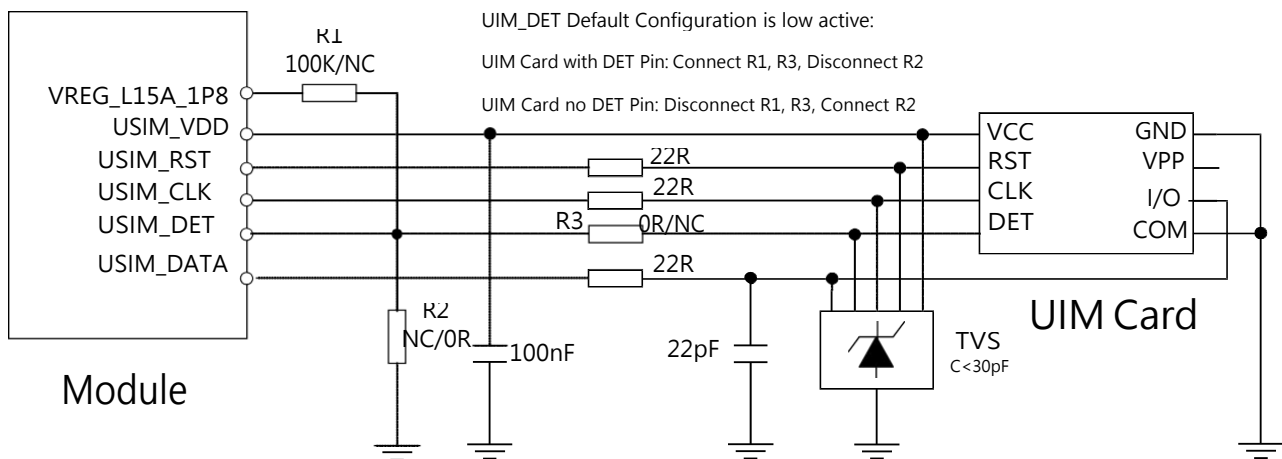

Figure 32: UIM Card Interface Reference Design

**NOTE**

1. The USIM\_DATA Pin of the module pulls up to the USIM\_VDD internally. Avoid external pull up.
2. Place the TVS close to the USIM Card receptacle interface.
3. Highly recommend the parasitic capacitance of the TVS on the USIM\_CLK should be less than 30pF.
4. Highly recommend the 22R resistor in series on the signal lines to enhance the ESD protection.
5. Highly recommend reserved 22pF capacitor pulling down to the ground on the USIM\_DATA line preventing the radio frequency interference.

### 3.14 ADC

SIM8918x series module offers one 16-Bit resolution ADC providing by the power management IC.

Parameter	Description	Minimum	Typical	Maximum	Unit
Input power domain	Programmable	0	-	1.875	V
Resolution		-	16	-	bits
Analog input bandwidth		-	500	-	kHz
Sample rate		-	4.8	-	MHz
ADC resolution (LSB)		-	64.879	-	uV
1/1 channel end-to-end accuracy	Calibrated data result	-11	6	11	mV
1/1 channel end-to-end accuracy with internal	Calibrated data result	-12.5	7	12.5	mV

pull-up					
1/3 channel end-to-end accuracy	Calibrated data result	-20	10	20	mV
100 K pull-up	Trimmed value	99.5	100	100.5	kΩ
400 K pull-up	Trimmed value	398	100	402	kΩ
30 K pull-up	Trimmed value	29.7	30	30.3	kΩ
1/1 channel AMUX input resistance		10	-	-	MΩ
1/3 channel AMUX input resistance		1	-	-	MΩ

**NOTE**

ADC input power domain is 0~1.875V. Highly recommend connecting the ADC with a resistance voltage division circuit preventing the module from burning due to the high power supply voltage ADC detection.

### 3.15 Sensor Interface

SIM8918x series module communicates with sensors via I2C or I3C. It supports various sensors, including the hall sensor, the acceleration sensor, the geomagnetism sensor, the gyroscope sensor, the temperature sensor, the light sensor, and the pressure sensor.

PIN Name	PIN Num	I/O	Description	Note
SENSOR_I2C_SCL	92	DO	Sensor I2C Clock Signal	Highly recommend an external 2.2KR resistor pulling up to the VREG_L15A_1P8
SENSOR_I2C_SDA	91	DI/DO	Sensor I2C Data Signal	
GPIO_32	99	DI	Accelerate Interruption Pin	ACCL_GYRO_INT1
GPIO_35	107	DI	PS/Light Sensor Interruption Pin	ALPS_INT_N
GPIO_33	108	DI	Gyroscope Sensor Interruption Pin	ACCL_GYRO_INT2
GPIO_34	109	DI	Magnetic Sensor Interruption Pin	MAG_INT_N
GPIO_36	110	DI	Hall Sensor Interruption Pin	HALL_INT
SNSR_I3C_SDA	167	DI	Sensor I3C Clock Signal	Highly recommend an external 2.2KR resistor pulling up to
SNSR_I3C_SCL	168	DI	Sensor I3C Clock Signal	

				the VREG_L15A_1P8
VREG_L15A_1P8	111	PO	Sensor I2C Pull Up VDD or VDDIO Power Supply	
VREG_L17A_3P0	129	PO	AVDD3.0V Power Supply for sensor	

### 3.16 Motor Interface

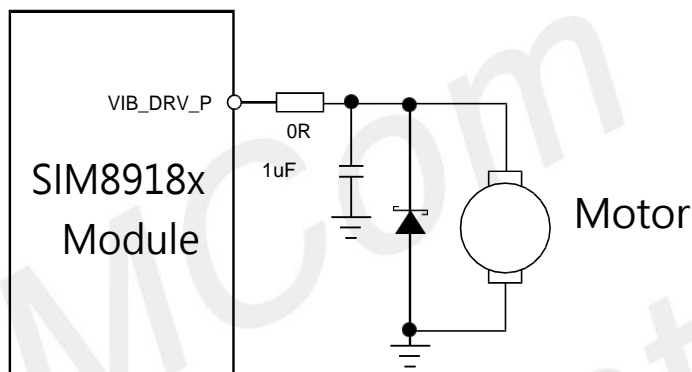

Figure 33: Motor Interface Reference Design

### 3.17 LED Interface

SIM8918x series module supports charge indicate LED. Selecting a LED chip with the common anode is needed. The maximum current on the channel is 5mA.

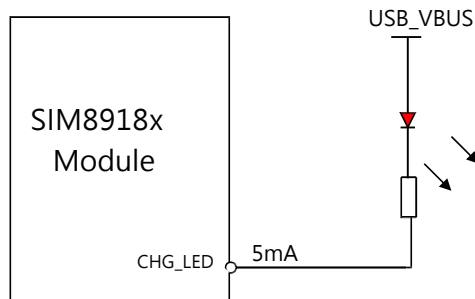

Figure 34: LEDs Interface Reference Design

### 3.18 Flash LED Interface

SIM8918x series module offers two channels of efficient FLASH\_LED interface. The maximum current on each channel is 1A.

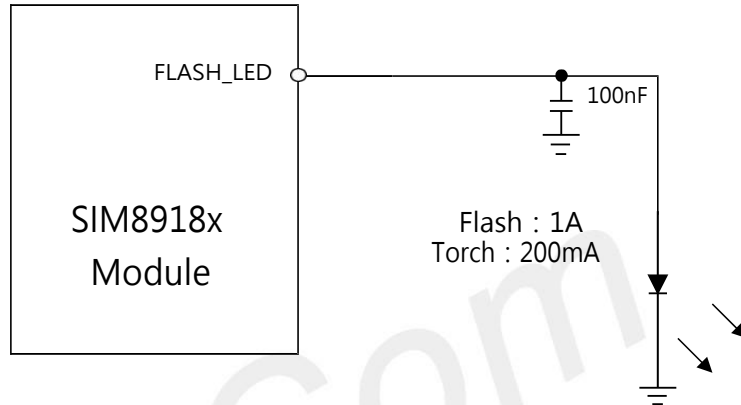

Figure 35: Flash LED Interface Reference Design

### 3.19 Forced Emergency Download Interface

SIM8918x series module offers a FORCED\_USB\_BOOT Pin, which is an emergency download interface. Pulling up the FORCED\_USB\_BOOT to the VREG\_L15A\_1P8 before powering on enables the module to run into the emergency download mode, which is also applying for the treatment when the product starts abnormally. Highly recommend reserved the testing points for software upgrading and debugging.

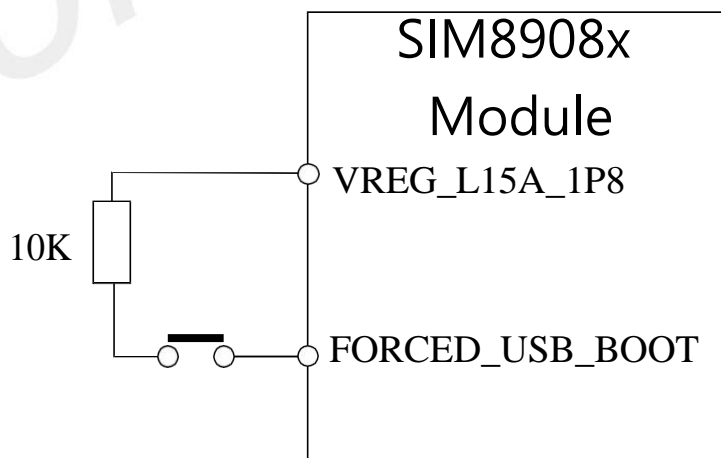

Figure 36: Emergency Download Interface Reference Design

## 4 WIFI & BT

SIM8918x series module offers a common antenna interface combining the WIFI and the BT function. The customers could connect the external WIFI and BT two in one antenna via this interface. In the TDD mode, the WIFI and the BT coexist.

### 4.1 WIFI Outline

SIM8918x series module supports the 2.4GHz and the 5GHz dual bands WLAN wireless communication. It supports multiple modes, including the 802.11a, the 802.11b, the 802.11g, the 802.11n, and the 802.11ac. The highest rate is 433Mbps. The characteristics are as follows.

- Support the 2.4GHz and the 5GHz dual frequency bands, with the frequencies of 2402MHz~2482MHz and 5180MHz~5825MHz respectively.
- Support the Wake-on-WLAN.
- Support the WAPI SMS4 hardware encryption.
- Support the AP mode and the STATION mode.
- Support the WIFI Direct.
- Support the 2.4G MCS 0~8 for HT20 and VHT20.
- Support the 2.4G MCS 0~7 for HT40 and VHT40.
- Support the 5G MCS 0~7 for HT20, HT40
- Support the 5G MCS 0~8 for VHT20.
- Support the 5G MCS 0~9 for VHT40 and VHT80.

#### 4.1.1 WIFI Feature

	Mode	Rate	Bandwidth	Output Power <sup>[1]</sup>
2.4GHz	802.11b	CCK 1Mbps	--	15dBm±2dB
	802.11b	CCK 11Mbps	--	15dBm±2dB
	802.11g	6Mbps	20M	15dBm±2dB
	802.11g	54Mbps	20M	15dBm±2dB
	802.11n HT20	MCS0	20M	15dBm±2dB



	802.11n HT20	MCS7	20M	15dBm±2dB
	802.11n HT40	MCS0	40M	14dBm±2dB
	802.11n HT40	MCS7	40M	14dBm±2dB
5GHz	802.11a	OFDM 6Mbps	20M	16dBm±2dB
	802.11a	OFDM 54Mbps	20M	8dBm±2dB
	802.11n HT20	MCS0	20M	16dBm±2dB
	802.11n HT20	MCS7	20M	10dBm±2dB
	802.11n HT40	MCS0	40M	13dBm±2dB
	802.11n HT40	MCS7	40M	8dBm±2dB
	802.11ac VHT20	MCS0	20M	16dBm±2dB
	802.11ac VHT20	MCS8	20M	8dBm±2dB
	802.11ac VHT40	MCS0	40M	13dBm±2dB
	802.11ac VHT40	MCS9	40M	8dBm±2dB
	802.11ac VHT80	MCS0	80M	11dBm±2dB
	802.11ac VHT80	MCS9	80M	8dBm±2dB

**NOTE**

The output power value is testing based on the standards of Mask and EVM.

	Standard	Speed	Bandwidth	Receiving Sensitivity
2.4GHz	802.11b	CCK 1Mbps	--	< -89dBm
	802.11b	CCK 11Mbps	--	< -79dBm
	802.11g	6Mbps	20M	< -85dBm
	802.11g	54Mbps	20M	< -68dBm
	802.11n HT20	MCS0	20M	< -85dBm
	802.11n HT20	MCS7	20M	< -67dBm
	802.11n HT40	MCS0	40M	< -82dBm
	802.11n HT40	MCS7	40M	< -64dBm
5GHz	802.11a	OFDM 6Mbps	20M	< -85dBm

802.11a	OFDM 54Mbps	20M	< -68dBm
802.11n HT20	MCS0	20M	< -85dBm
802.11n HT20	MCS7	20M	< -67dBm
802.11n HT40	MCS0	40M	< -82dBm
802.11n HT40	MCS7	40M	< -64dBm
802.11ac VHT20	MCS0	20M	< -85dBm
802.11ac VHT20	MCS8	20M	< -62dBm
802.11ac VHT40	MCS0	40M	< -82dBm
802.11ac VHT40	MCS9	40M	< -57dBm
802.11ac VHT80	MCS0	80M	< -79dBm
802.11ac VHT80	MCS9	80M	< -54dBm

## 4.2 BT Outline

SIM8918x series module supports the BT5.0. It supports multiple modes, including the GFSK, the 8-DPSK, and the  $\pi/4$ -DQPSK. The performance indexes are showing as follows.

### BT RF Feature

BLE Emission Power: 7dBm $\pm$ 2dB

#### Emission Feature

Mode	DH5	2DH5	3DH5
Emission Power	10dBm $\pm$ 2dB	8dBm $\pm$ 2dB	8dBm $\pm$ 2dB

#### Receiving Feature

Mode	DH5	2DH5	3DH5
Receiving Sensitivity	< -90dBm	< -90dBm	< -80dBm

## 5 GNSS

SIM8918x series module supports multiple positioning systems, including the GPS, the GLONSS, and the BeiDou. LNA is a built-in component in the module to effectively enhance the receiving sensitivity of GNSS.

### 5.1 GNSS Outline

Parameter	Status	Typical	Unit
CNO	CN Value	44 @ -130dBm	dB/Hz
Static Drift	CEP-50	5	m
Sensitivity	Tracking	≤ -159	dBm
	Recapturing	≤ -156	dBm
	Cold Booting	≤ -148	dBm
TTFF	Cold Booting	<35	s
	Warm Booting	<15	s
	Hot Booting	<5	s

### 5.2 GNSS RF & Antenna Design Guideline

The GNSS signal is a weak signal. If the antennas and the routings are not designed properly, it is easy to interfere with the GNSS signal, resulting in the decline of the GNSS receiving sensitivity, and even the GNSS positioning time. To avoid the negative effects, the following principles shall be observed in GNSS RF Design.

- The isolation between the GNSS antenna and other antennas shall be at least 15dB.
- The GNSS RF signal lines and RF related components must be away from the high-speed signals, the power switch signals, and other clock signals.
- The GNSS antenna must be away from the LCD screen, the camera, and other peripherals.
- The GNSS antenna shall be placed close to the top of the equipment as far as possible.
- Refer to chapter 6.4 for the GNSS antenna reference design.

## 6 Antenna Interface

SIM8918x series module has four antenna interfaces, including the MAIN antenna, the DRX antenna, the GNSS antenna, and the WIFI/BT antenna. To ensure the well RF performance of the products, the RF lines wiring through the antenna pin to the antenna interfaces must meet the following requirements.

- Ensure the RF lines are wiring with the 50Ω impedance.
- The RF lines must have a complete stereo ground plane.
- The RF lines must away from the other interference sources, including the high-speed signals, the clock signals, the sound sensing devices, and the motor, etc.
- The RF lines shall be as short as possible to avoid loss and interference.

### 6.1 MAIN Antenna & DRX Antenna

The MAIN antenna interface and the DRX antenna interface feature are showing as follows.

MAIN Antenna & DRX Antenna Feature

PIN Name	PIN Num	I/O	Description	Feature
ANT_MAIN	87	AI/AO	2G/3G/4G Main Antenna Interface	50Ω Impedance
ANT_DRX	131	AI	4G DRX Antenna Interface	50Ω Impedance

#### 6.1.1 Operating Frequency Band and Maximum power:

SIM8918x series module's operating frequency bands are showing as follows.

Operating Frequency Band

Band	Frequency	Maximum power	Channel
GSM850	824-849MHz	33.0 dBm±0.5	
GSM1900	1850-1910MHz	29.0 dBm±0.5	

WCDMA B II	1850-1910MHz	23.0dBm +1/-3	
WCDMA B V	824-849MHz	22.5dBm +1/-3	
WCDMA B IV	1710-1755 MHz	22.5dBm +1/-3	
LTE B2	1850-1910 MHz	23.0dBm $\pm$ 0.5	
LTE B4	1710-1755 MHz	23.0dBm	
LTE B5	824-849MHz	23.0dBm $\pm$ 0.5	
LTE B7	2500-2570MHz	23.0dBm $\pm$ 0.5	
LTE B12	699-716MHz	23.0dBm $\pm$ 1.0	
LTE B13	777-787MHz	23.0dBm $\pm$ 0.5	
LTE B17	704-716MHz	23.0dBm $\pm$ 1.0	
LTE B25	1850-1915MHz	23.0dBm	
LTE B26	814-849MHz	23.0dBm $\pm$ 1.5	
LTE B38	2570-2620MHz	23.0dBm $\pm$ 0.5	
LTE B41	2496-2690MHz	23.0dBm $\pm$ 0.5	
LTE B66	1710-1780MHz	23.0dBm $\pm$ 0.5	

LTE B71	663-698MHz	23.0dBm $\pm$ 0.5	
GNSS(BDS/ Galileo/ GLONASS/GPS):	1559~1610 MHz	/	/

### 6.1.2 RF Reference Design

SIM8918x series module's MAIN antenna reference design is showing as follows.

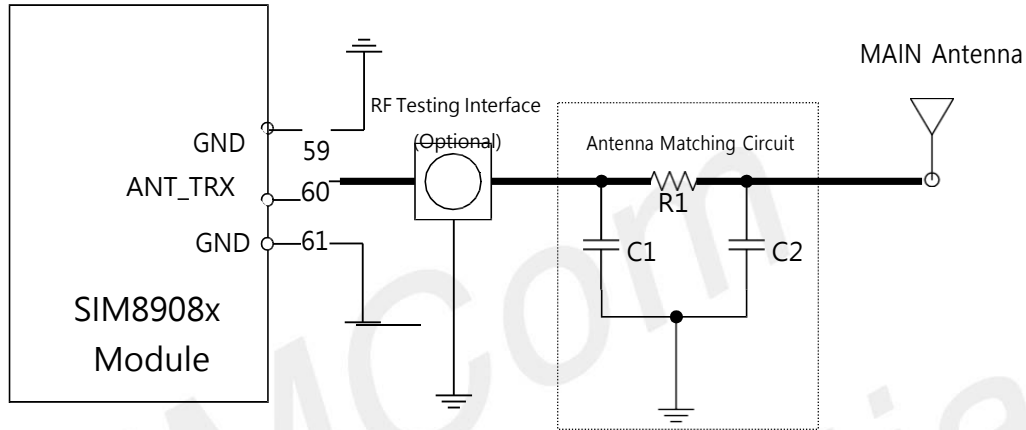

Figure 37: MAIN Antenna Reference Design

R1, C1, and C2 are the antenna matching components. All these three components are adjustable to match the efficient and effective communication quality based on the interface debugging result. Selecting R1 with 0R resistor by default, and reserved C1 and C2 with disconnection by default. Highly recommend reserved an RF testing interface to modify accurately and conveniently. Considering the low cost, recommend ensure 50Ω impedance for the RF lines and cancel the RF testing interface.

SIM8918x series module's DRX antenna reference design is showing as follows.

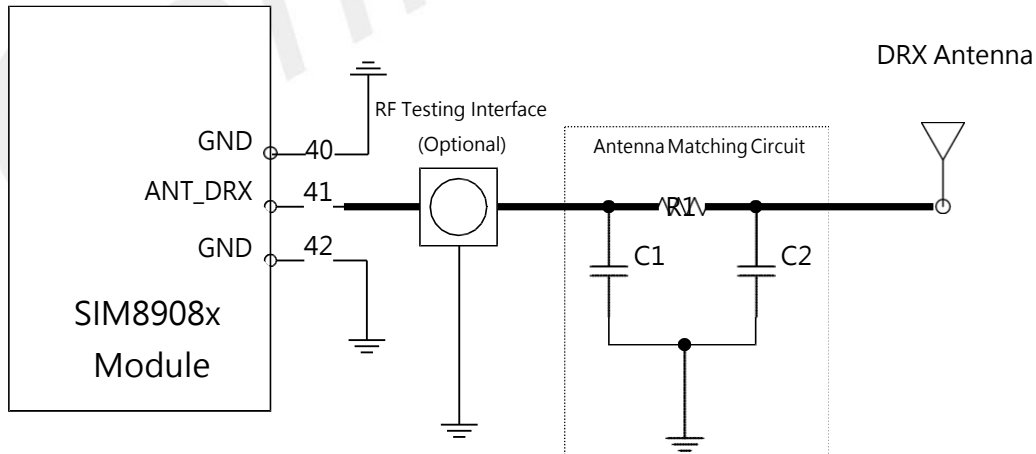

Figure 38: DRX Antenna Reference Design

R1, C1 and C2 are the antenna matching components. All these three components are adjustable to match the efficient and effective communication quality based on the interface debugging result. Selecting R1 with 0R resistor by default, and reserved C1 and C2 with disconnection by default. Highly recommend reserved an RF testing interface to modify accurately and conveniently. Considering the low cost, recommend ensure

50Ω impedance for the RF lines and cancel the RF testing interface.

## 6.2 WIFI/BT Antenna Interface

SIM8918x series module's WIFI/BT antenna interface feature is showing as follows.

WIFI/BT Antenna Feature

PIN Name	PIN Num	I/O	Description	Feature
ANT_WIFI/BT	77	AI/AO	WIFI/BT Antenna Interface	50Ω Impedance

SIM8918x series module's WIFI/BT operating frequency bands are showing as follows.

WIFI/BT Operating Frequency Band and Maximum power

Type	Frequency Band	Maximum Power
802.11a/b/g/n/ac	2412MHz~2462 MHz 5150 MHz ~5825 MHz	16.0dBm ±0.5
BT 5.0	2402 MHz ~2480 MHz	10.5dBm ±1

SIM8918x series module's WIFI/BT antenna reference design is showing as follows.

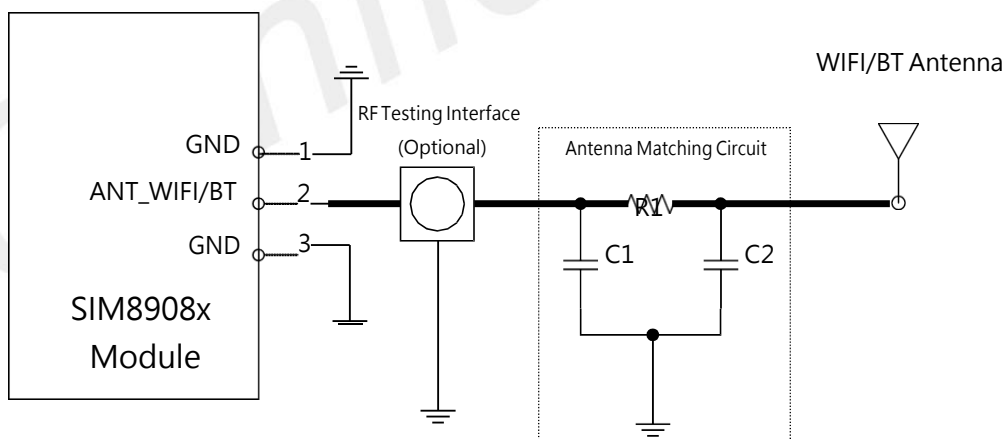

Figure 39: WIFI/BT Antenna Reference Design

In Figure 37, R1, C1 and C2 are the antenna matching components. All these three components are adjustable to match the efficient and effective communication quality based on the interface debugging result. Selecting R1 with 0R resistor by default, and reserved C1 and C2 with disconnection by default. Highly recommend reserved an RF testing interface to modify accurately and conveniently. Considering the



low cost, recommend ensure 50Ω impedance for the RF lines and cancel the RF testing interface.

### 6.3 GNSS Antenna Interface

SIM8918x series module's GNSS antenna interface feature is showing as follows.

GNSS Antenna Feature

PIN Name	PIN Num	I/O	Description	Feature
ANT_GNSS	121	AI	GNSS Antenna Interface	50Ω Impedance

SIM8918x series module's GNSS operating frequency bands are showing as follows.

GNSS Operating Frequency Band

Type	Frequency Band	Unit
GPS	1575.42±1.023	MHz
GLONASS	1597.5~1605.8	MHz
BeiDou	1559.05 – 1563.14	MHz

#### 6.3.1 GNSS Passive Antenna Reference Design

SIM8918x series module's GNSS passive antenna reference design is showing as follows.

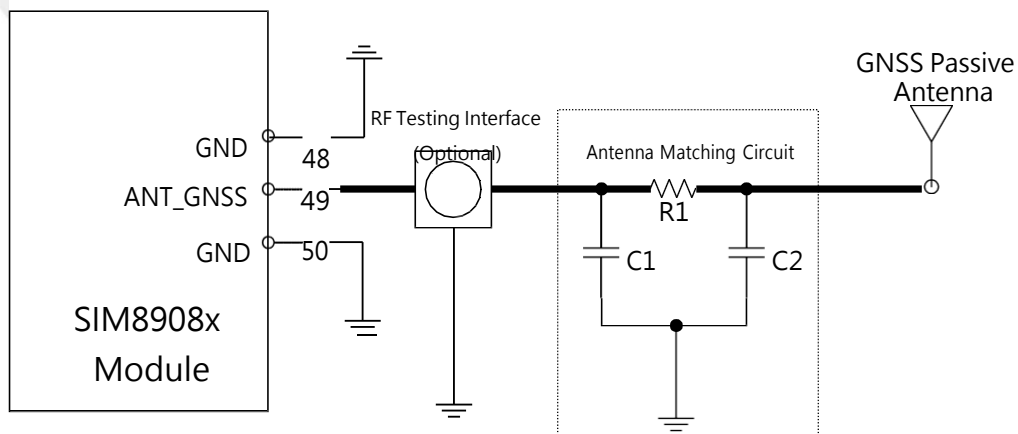

Figure 40: GNSS Passive Antenna Reference Design

R1, C1 and C2 are the antenna matching components. All these three components are adjustable to match the efficient and effective communication quality based on the interface debugging result. Selecting R1 with 0R resistor by default, and reserved C1 and C2 with disconnection by default. Highly recommend reserved an RF testing interface to modify accurately and conveniently. Considering the low cost, recommend ensure 50Ω impedance for the RF lines and cancel the RF testing interface.

### 6.3.2 GNSS Active Antenna Reference Design

SIM8918x series module's GNSS active antenna reference design is showing as follows.

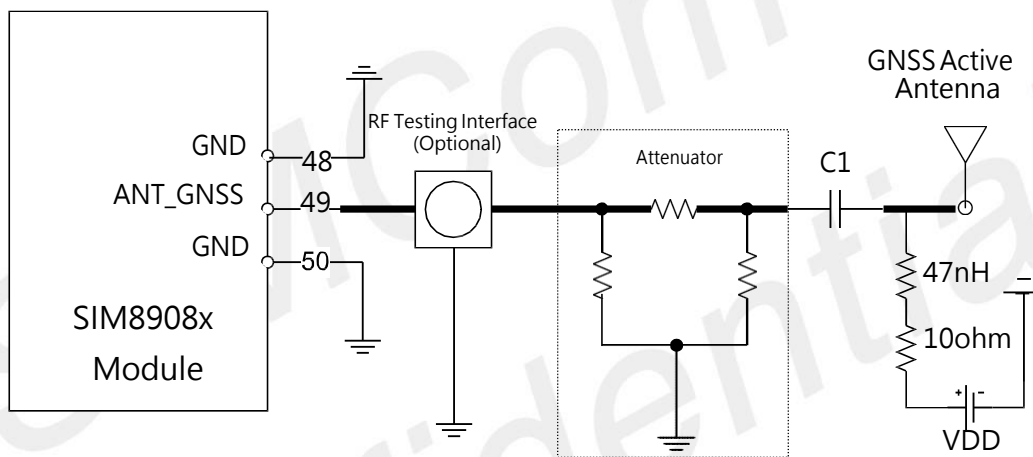

Figure 41: GNSS Active Antenna Reference Design

In Figure 39, highly recommend reserved the attenuator, and the attenuation value is determined by the gain of the external active antenna. Generally speaking, the attenuation value and antenna gain of the attenuator meet the following formula.

$$\text{Antenna Gain} = \text{Attenuation value} + \text{Cable Losses}$$

VDD is using to for the active antenna's power supply. The voltage value is determined by the antenna's feature. C1 is using to isolate straight, and the default value is 33pF. Highly recommend reserved an RF testing interface to modify accurately and conveniently. Considering the low cost, recommend ensure 50Ω impedance for the RF lines and cancel the RF testing interface.

## 6.4 RF Signals PCB Wiring Guideline

Highly recommend the characteristic impedance of all RF signal lines shall be controlled at 50Ω when the

customers route their PCB. Generally, the impedance of RF signal lines is determined by the dielectric constant (ER), the wiring width (W), the ground clearance (S), the height of the reference ground plane (H), and other factors.

RF routing characteristic impedance control usually adopts the microstrip-slot line and the coplanar waveguide-slot line. The reference designs of 50Ω impedance are showing as follows.

- **Micro strip-slot Line Structure**

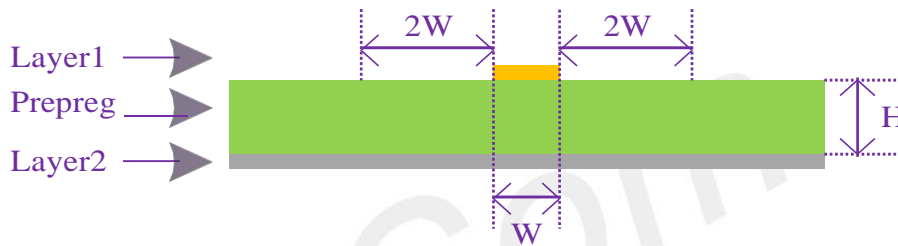

Figure 42: Two Layers PCB Microstrip-slot Line Structure

Two Layers PCB Microstrip-slot Line Structure Impedance Control Feature

Thickness	Er	Signal Thickness	Signal Layer	Reference Layer	Impedance	Width
1mm	4.2	0.035mm	Layer1	Layer2	50 ohm	1.7mm (67 mil)
1.6mm	4.2	0.035mm	Layer1	Layer2	50 ohm	3mm (118 mil)

- **Coplanar Waveguide-slot Line**

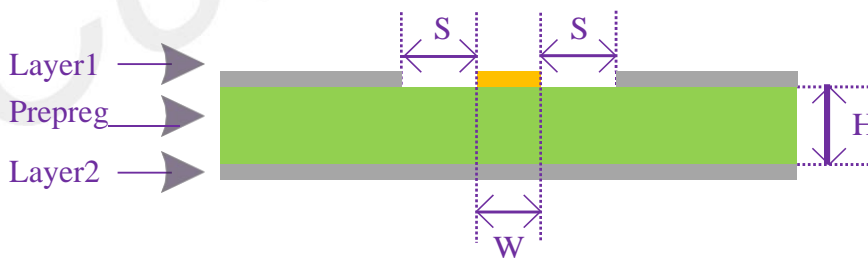

Figure 43: Two Layers PCB Coplanar Waveguide-slot Line Structure

Two Layers PCB Coplanar Waveguide-slot Line Structure Impedance Control Feature

Thickness	Er	Signal Thickness	Signal	Reference	Impedance	S	W
1mm	4.2	0.035mm	Layer1	Layer2	50 ohm	0.65mm (25.6 mil)	0.2mm (7.8 mil)
1.6mm	4.2	0.035mm	Layer1	Layer2	50 ohm	0.65mm (25.6 mil)	0.15mm (5.9 mil)

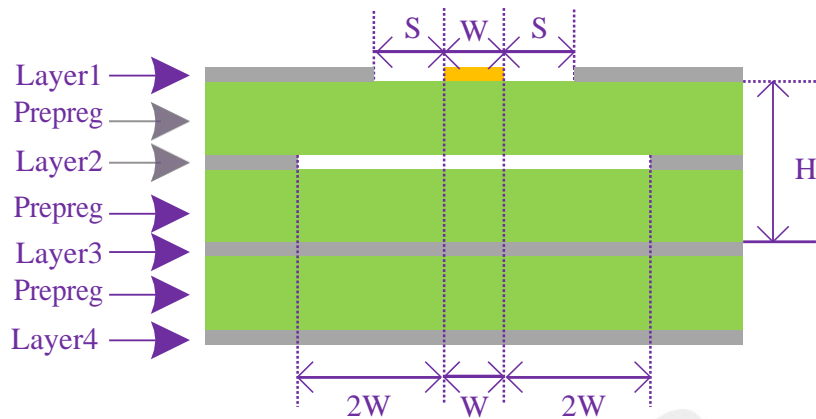

Figure 44: Four Layers PCB Coplanar Waveguide-slot Line Structure (Reference Layer Three)

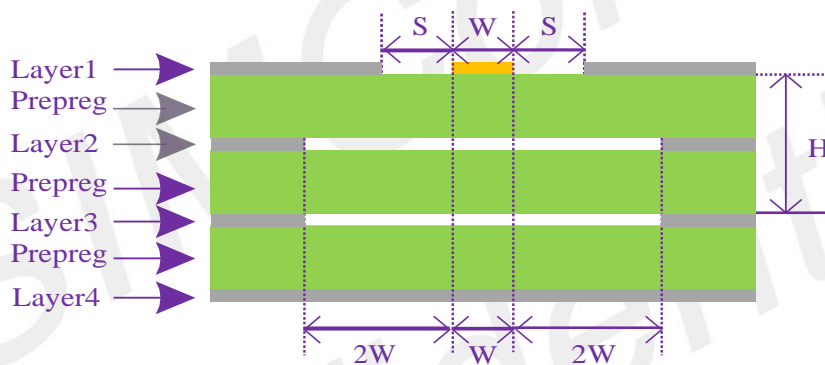

Figure 45: Four Layers PCB Coplanar Waveguide-slot Line Structure (Reference Layer Four)

To ensure the well RF performance of the products, the RF lines wiring through the antenna pin to the antenna interfaces must meet the following requirements.

- Ensure the RF lines are wiring with the 50Ω impedance.
- The RF lines must have a complete stereo ground plane.
- Add more ground holes around the RF signal lines and the reference ground to enhance the RF performance.
- The RF lines must away from the other interference sources, including the high-speed signals, the clock signals, the sound sensing devices, and the motor, etc.
- The RF lines shall be as short as possible to avoid loss and interference.
- The GND pin adjacent to the RF interface pin of the module is not subject to thermal pad treatment and is in full contact with the ground.
- Avoid wiring crossing the whole PCB. Avoid the right-angle routing. Highly recommend wiring with a circular arc or a 135-degree routing.
- Be aware of the distance between the components and the lower PCB ground, especially for the RF connecting device package.
- Digging out the GND copper foil on the surface of the PCB below the connector if necessary.
- The distance between the ground hole and the signal line shall be at least 2 times the line width( $2*W$ ).

## 6.5 Antenna Installation

### 6.5.1 GNSS Passive Antenna Reference Design

SIM8918x series module's antenna interface installation requirements are showing as follows.

#### Antenna Installation Requirements





Antenna	Parameters' Requirements
GSM/WCDMA/LTE	Standing wave ratio: $\leq 2$ Gain (dBi): GSM/GPRS/EDGE 850: 0.64 dBi GSM/GPRS/EDGE 1900: 2.12 dBi WCDMA/HSDPA/HSUPA Band II: 2.12 dBi WCDMA/HSDPA/HSUPA Band IV: 2.95 dBi WCDMA/HSDPA/HSUPA Band V: 0.64 dBi LTE FDD Band 2: 2.12 dBi LTE FDD Band 4: 2.95 dBi LTE FDD Band 5: 0.64 dBi LTE FDD Band 7: 2.90 dBi LTE FDD Band 12: 1.57 dBi LTE FDD Band 13: 2.23 dBi LTE FDD Band 17: 1.57 dBi LTE FDD Band 25: 1.87 dBi LTE FDD Band 26: 1.40 dBi LTE FDD Band 66: 2.95 dBi LTE FDD Band 71: 0.22 dBi LTE TDD Band 38: 1.64 dBi LTE TDD Band 41: 2.90 dBi Maximum Input Power (W): 50 Input Impedance ( $\Omega$ ): 50 Polarization Type: Vertical Insertion Loss: $< 1$ dB (GSM850/GSM1900, WCDMA B2/B4/B5, LTE B2/B4/B5/B7/B12/B13/B25/B26)
Wi-Fi/BT	Standing wave ratio: $\leq 2$ (2.4G) Gain (dBi): 4.01 (5G) Gain (dBi): 4.32 Maximum Input Power (W): 50 Input Impedance ( $\Omega$ ): 50 Polarization Type: Vertical

GNSS

Frequency Range: 1559 - 1607MHz  
Polarization Type: Right-Handed Circular or Linear Polarization  
Standing wave ratio: < 2 (Typical)  
Passive Antenna Gain: > 0dBi  
Active Antenna Noise Coefficient: < 1.5dB (Typical)  
Active Antenna Gain: > -2dBi  
Active Antenna Integrated LNA Gain: <17dB (Typical)  
Active Antenna Total Gain: <17dBi (Typical)

## 6.6 Safety Caution

### Safety Caution

Marks	Requirements
	<p>When in a hospital or other health care facility, observe the restrictions about the use of mobiles. Switch the cellular terminal or mobile off, medical equipment may be sensitive and not operate normally due to RF energy interference.</p>
	<p>Switch off the cellular terminal or mobile before boarding an aircraft. Make sure it is switched off. The operation of wireless appliances in an aircraft is forbidden to prevent interference with communication systems. Forgetting to think much of these instructions may impact the flight safety, or offend local legal action, or both.</p>
	<p>Do not operate the cellular terminal or mobile in the presence of flammable gases or fumes. Switch off the cellular terminal when you are near petrol stations, fuel depots, chemical plants or where blasting operations are in progress. Operation of any electrical equipment in potentially explosive atmospheres can constitute a safety hazard.</p>
	<p>Your cellular terminal or mobile receives and transmits radio frequency energy while switched on. RF interference can occur if it is used close to TV sets, radios, computers or other electric equipment.</p>
	<p>Road safety comes first! Do not use a hand-held cellular terminal or mobile when driving a vehicle, unless it is securely mounted in a holder for hands free operation. Before making a call with a hand-held terminal or mobile, park the vehicle.</p>



GSM cellular terminals or mobiles operate over radio frequency signals and cellular networks and cannot be guaranteed to connect in all conditions, especially with a mobile fee or an invalid SIM card. While you are in this condition and need emergent help, please remember to use emergency calls. In order to make or receive calls, the cellular terminal or mobile must be switched on and in a service area with adequate cellular signal strength.

Some networks do not allow for emergency call if certain network services or phone features are in use (e.g. lock functions, fixed dialing etc.). You may have to deactivate those features before you can make an emergency call.

Also, some networks require that a valid SIM card be properly inserted in the cellular terminal or mobile.

### **FCC Statement**

This device complies with part 15 of the FCC rules. Operation is subject to the following two conditions: (1) this device may not cause harmful interference, and (2) this device must accept any interference received, including interference that may cause undesired operation.

Changes or modifications not expressly approved by the party responsible for compliance could void the user's authority to operate the equipment.

NOTE: This equipment has been tested and found to comply with the limits for a Class B digital device, pursuant to part 15 of the FCC Rules. These limits are designed to provide reasonable protection against harmful interference in a residential installation. This equipment generates uses and can radiate radio frequency energy and, if not installed and used in accordance with the instructions, may cause harmful interference to radio communications. However, there is no guarantee that interference will not occur in a particular installation. If this equipment does cause harmful interference to radio or television reception, which can be determined by turning the equipment off and on, the user is encouraged to try to correct the interference by one or more of the following measures:

- Reorient or relocate the receiving antenna.
- Increase the separation between the equipment and receiver.
- Connect the equipment into an outlet on a circuit different from that to which the receiver is connected.
- Consult the dealer or an experienced radio/TV technician for help.

Important Note:

### **Radiation Exposure Statement**

This equipment complies with FCC radiation exposure limits set forth for an uncontrolled environment. This equipment should be installed and operated with minimum distance 20cm between the radiator and your body. This transmitter must not be co-located or operating in conjunction with any other antenna or transmitter. Country Code selection feature to be disabled for products marketed to the US/Canada.

This device is intended only for OEM integrators under the following conditions:

1. The antenna must be installed such that 20 cm is maintained between the antenna and users, and
2. The transmitter module may not be co-located with any other transmitter or antenna,
3. For all products market in US, OEM has to limit the operation channels in CH1 to CH11 for 2.4G band by supplied firmware programming tool. OEM shall not supply any tool or info to the end-user regarding to Regulatory Domain change. (if modular only test Channel 1-11)

As long as the three conditions above are met, further transmitter testing will not be required. However, the OEM integrator is still responsible for testing their end-product for any additional compliance requirements required with this module installed.

### **Important Note:**

In the event that these conditions cannot be met (for example certain laptop configurations or co-location with another transmitter), then the FCC authorization is no longer considered valid and the FCC ID cannot be used on the final product. In these circumstances, the OEM integrator will be responsible for re-evaluating the end product (including the transmitter) and obtaining a separate FCC authorization.



## End Product Labeling

The final end product must be labeled in a visible area with the following "Contains FCC ID: 2AJYU-8XRA002".

## Manual Information to the End User

The OEM integrator has to be aware not to provide information to the end user regarding how to install or remove this RF module in the user's manual of the end product which integrates this module.

The end user manual shall include all required regulatory information/warning as show in this manual.

## ISED Statement

- English: This device complies with Industry Canada license-exempt RSS standard(s).

Operation is subject to the following two conditions: (1) This device may not cause interference, and (2) This device must accept any interference, including interference that may cause undesired operation of the device.

The digital apparatus complies with Canadian CAN ICES-3 (B)/NMB-3(B).

- French: Le présent appareil est conforme aux CNR d'Industrie Canada applicables aux appareils radio exempts de licence. L'exploitation est autorisée aux deux conditions suivantes: (1) l'appareil ne doit pas produire de brouillage, et (2) l'utilisateur de l'appareil doit accepter tout brouillage radioélectrique subi, même si le brouillage est susceptible d'en compromettre le fonctionnement.

This radio transmitter (ISED certification number: 23761-8XRA002) has been approved by Industry Canada to operate with the antenna types listed with the maximum permissible gain indicated. Antenna types not included in this list, having a gain greater than the maximum gain indicated for that type, are strictly prohibited for use with this device.

Le présent émetteur radio (ISED certification number: 23761-8XRA002) a été approuvé par Industrie Canada pour fonctionner avec les types d'antenne énumérés ci-dessous et ayant un gain admissible maximal. Les types d'antenne non inclus dans cette liste, et dont le gain est supérieur au gain maximal indiqué, sont strictement interdits pour l'exploitation de l'émetteur.

**Antenna Type:** External Antenna

### Antenna Gain:

WCDMA/HSDPA/HSUPA Band II: 2.12 dBi

WCDMA/HSDPA/HSUPA Band IV: 2.95 dBi

WCDMA/HSDPA/HSUPA Band V: 0.64 dBi

LTE FDD Band 2: 2.12 dBi

LTE FDD Band 4: 2.95 dBi

LTE FDD Band 5: 0.64 dBi

LTE FDD Band 7: 2.90 dBi

LTE FDD Band 12: 1.57 dBi

LTE FDD Band 13: 2.23 dBi

LTE FDD Band 17: 1.57 dBi

LTE FDD Band 25: 1.87 dBi

LTE FDD Band 26: 1.40 dBi

LTE TDD Band 41: 2.90 dBi

LTE FDD Band 66: 2.95 dBi

LTE FDD Band 71: 0.22 dBi

WLAN 2.4G&Bluetooth: 4.53dBi

WLAN 5G: 4.66dBi

## Radiation Exposure Statement

This equipment complies with Canada radiation exposure limits set forth for an uncontrolled environment. This equipment should be installed and operated with minimum distance 20cm between the radiator & your body.

### **Déclaration d'exposition aux radiations**

Cet équipement est conforme Canada limites d'exposition aux radiations dans un environnement non contrôlé. Cet équipement doit être installé et utilisé à distance minimum de 20cm entre le radiateur et votre corps.

This device is intended only for OEM integrators under the following condition:

The transmitter module may not be co-located with any other transmitter or antenna.

As long as the condition above is met, further transmitter test will not be required. However, the OEM integrator is still responsible for testing their end-product for any additional compliance requirements required with this module installed.

Cet appareil est conçu uniquement pour les intégrateurs OEM dans les conditions suivantes:

Le module émetteur peut ne pas être coimplanté avec un autre émetteur ou antenne.

Tant que les 1 condition ci-dessus sont remplies, des essais supplémentaires sur l'émetteur ne seront pas nécessaires. Toutefois, l'intégrateur OEM est toujours responsable des essais sur son produit final pour toutes exigences de conformité supplémentaires requis pour ce module installé.

### **Important Note:**

In the event that these conditions cannot be met (for example certain laptop configurations or co-location with another transmitter), then the Canada authorization is no longer considered valid and the IC cannot be used on the final product. In these circumstances, the OEM integrator will be responsible for re-evaluating the end product (including the transmitter) and obtaining a separate Canada authorization.

Note Importante:

Dans le cas où ces conditions ne peuvent être satisfaites (par exemple pour certaines configurations d'ordinateur portable ou de certaines co-localisation avec un autre émetteur), l'autorisation du Canada n'est plus considéré comme valide et l'IC ne peut pas être utilisé sur le produit final. Dans ces circonstances, l'intégrateur OEM sera chargé de réévaluer le produit final (y compris l'émetteur) et l'obtention d'une autorisation distincte au Canada.

End Product Labeling

The final end product must be labeled in a visible area with the following: Contains IC: 23761-8XRA002.

Plaque signalétique du produit final

Le produit final doit être étiqueté dans un endroit visible avec l'inscription suivante: Contient des IC: 23761-8XRA002

### **Manual Information to the End User**

The OEM integrator has to be aware not to provide information to the end user regarding how to install or remove this RF module in the user's manual of the end product which integrates this module.

The end user manual shall include all required regulatory information/warning as show in this manual.

Manuel d'information à l'utilisateur final

L'intégrateur OEM doit être conscient de ne pas fournir des informations à l'utilisateur final quant à la façon d'installer ou de supprimer ce module RF dans le manuel de l'utilisateur du produit final qui intègre ce module.

Le manuel de l'utilisateur final doit inclure toutes les informations réglementaires requises et avertissements comme indiqué dans ce manuel.

Caution:

- (i) The device for operation in the band 5150–5250 MHz is only for indoor use to reduce the potential for harmful interference to co-channel mobile satellite systems;
- (ii) For devices with detachable antenna(s), the maximum antenna gain permitted for devices in the bands 5250-5350 MHz and 5470-5725 MHz shall be such that the equipment still complies with the EIRP limit;
- (iii) For devices with detachable antenna(s), the maximum antenna gain permitted for devices in the band 5725-5850 MHz shall be such that the equipment still complies with the EIRP limits specified for point-to-point and non-point-to-point operation as appropriate; and

Operations in the 5.25-5.35GHz band are restricted to indoor usage only.

In addition, for the frequency band 5600-5650MHz of Canadian weather radar work, the equipment is limited by software to limit the work of this frequency band, and the user can not independently change.

**Avvertimento:**

- (i) i dispositivi funzionanti nella banda di 5150 a 5250MHz sono riservati unicamente per un utilizzo all'interno al fine di ridurre i rischi di interferenza pregiudiziale ai sistemi di satelliti mobili utilizzando gli stessi canali;
- (ii) per i dispositivi muniti di antenne rimovibili, il guadagno massimo dell'antenna permesso per i dispositivi utilizzando le bande di 5250 a 5350MHz e di 5470 a 5725 MHz deve essere conforme al limite della p.i.r.e.;
- (iii) per i dispositivi muniti di antenne rimovibili, il guadagno massimo dell'antenna permesso (per i dispositivi utilizzando la banda di 5725 a 5850 MHz) deve essere conforme al limite della p.i.r.e. specificata per l'uso punto a punto e l'uso non punto a punto, a seconda del caso;

Le operazioni nella banda di 5.25-5.35GHz sono limitate a un uso interno solo.