



SIM7906G-M2_R2 Hardware Design (2x2MIMO)

LTE Module

SIMCom Wireless Solutions Limited

SIMCom Headquarters Building, Building 3, No. 289 Linhong

Changning District, Shanghai P.R.China

Tel: 86-21-31575100

support@simcom.com

Document Title:	SIM7906G-M2_R2 Hardware Design (2x2MIMO)
Version:	V1.02
Date:	2022-05-13
Status:	Released

GENERAL NOTES

SIMCOM OFFERS THIS INFORMATION AS A SERVICE TO ITS CUSTOMERS, TO SUPPORT APPLICATION AND ENGINEERING EFFORTS THAT USE THE PRODUCTS DESIGNED BY SIMCOM. THE INFORMATION PROVIDED IS BASED UPON REQUIREMENTS SPECIFICALLY PROVIDED TO SIMCOM BY THE CUSTOMERS. SIMCOM HAS NOT UNDERTAKEN ANY INDEPENDENT SEARCH FOR ADDITIONAL RELEVANT INFORMATION, INCLUDING ANY INFORMATION THAT MAY BE IN THE CUSTOMER'S POSSESSION. FURTHERMORE, SYSTEM VALIDATION OF THIS PRODUCT DESIGNED BY SIMCOM WITHIN A LARGER ELECTRONIC SYSTEM REMAINS THE RESPONSIBILITY OF THE CUSTOMER OR THE CUSTOMER'S SYSTEM INTEGRATOR. ALL SPECIFICATIONS SUPPLIED HEREIN ARE SUBJECT TO CHANGE.

COPYRIGHT

THIS DOCUMENT CONTAINS PROPRIETARY TECHNICAL INFORMATION WHICH IS THE PROPERTY OF SIMCOM WIRELESS SOLUTIONS LIMITED. COPYING, TO OTHERS AND USING THIS DOCUMENT, ARE FORBIDDEN WITHOUT EXPRESS AUTHORITY BY SIMCOM. OFFENDERS ARE LIABLE TO THE PAYMENT OF INDEMNIFICATIONS. ALL RIGHTS RESERVED BY SIMCOM IN THE PROPRIETARY TECHNICAL INFORMATION, INCLUDING BUT NOT LIMITED TO REGISTRATION GRANTING OF A PATENT, A UTILITY MODEL OR DESIGN. ALL SPECIFICATION SUPPLIED HEREIN ARE SUBJECT TO CHANGE WITHOUT NOTICE AT ANY TIME.

SIMCom Wireless Solutions Limited

SIMCom Headquarters Building, Building 3, No. 289 Linhong Road, Changning District, Shanghai
P.R.China
Tel: +86 21 31575100
Email: simcom@simcom.com

For more information, please visit:

<https://www.simcom.com/download/list-863-en.html>

For technical support, or to report documentation errors, please visit:

<https://www.simcom.com/ask/> or email to: support@simcom.com

Copyright © 2021 SIMCom Wireless Solutions Limited All Rights Reserved.

Version History

Date	Version	Description of change	Author
2021-11-12	V1.01	Original version	Dong Liu、Meng Hu
2022-05-13	V1.02	<ol style="list-style-type: none">1. Add eSIM description.2. Add PIN22 and PIN28 description.3. Description the hardware not support audio by default.4. Add Table1 SIM7906A/E/G-M2 frequency bands.5. Modified supply power VBAT:3.135~4.4V,Typ:3.3V.	Dong Liu、Yi Zheng

SIMCom
Confidential

Contents

1	Introduction.....	9
1.1	Product Outline.....	9
1.2	Hardware Block Diagram	10
1.3	Functional Overview	11
2	Package Information	13
2.1	Top and Bottom View of Module.....	13
2.2	Pin Assignment Overview.....	14
2.2.1	WLAN ZIF Connector.....	14
2.3	Pin Description	15
2.4	Package Dimensions.....	20
2.5	Label information	21
3	Interface Application	22
3.1	Power Supply	22
3.1.1	Power Supply Design Guide.....	22
3.1.2	Recommended Power Supply Circuit.....	24
3.1.3	Voltage Monitor	25
3.2	Full_Card_Power_Off#.....	25
3.2.1	Power on	26
3.2.2	Power off	27
3.3	Reset Function	28
3.4	UART interface	29
3.5	I2C Interface	31
3.6	WoWWAN#.....	32
3.7	USB Interface	33
3.8	PCIe Interface.....	36
3.9	USIM Interface.....	38
3.9.1	USIM Application Guide	38
3.9.2	USIM layout guide.....	40
3.10	I2S Interface	40
3.11	DPR	42
3.12	CONFIG Pins.....	43
3.13	LED1#.....	43
3.14	W_DISABLE1#.....	44
3.15	ANTCTRL interface	45
3.16	W_DISABLE2#.....	45
3.17	FORCE DOWNLOAD & GET DEBUG LOG	46
3.17.1	Forcing USB Boot	47
3.17.2	Get UART log.....	48

4	Antenna Interfaces	49
4.1	Antenna Definitions.....	49
4.1.1	WCDMA/LTE Operating Frequency	49
4.1.2	GNSS Frequency	50
4.2	Antenna Installation	51
4.2.1	Antenna Requirements.....	51
4.2.2	Recommended RF Connector for Antenna Installation	51
5	Electrical Specifications.....	54
5.1	Absolute maximum ratings	54
5.2	Operating conditions	54
5.3	Operating Mode.....	56
5.3.1	Operating Mode Definition.....	56
5.3.2	Sleep mode	57
5.3.3	Minimum functionality mode and Flight mode.....	57
5.4	RF Output Power/ Current Consumption	58
5.5	Conducted Receive Sensitivity.....	60
5.6	ESD	62
6	Connect SIM7906G-M2 to board	63
7	Thermal Design.....	64
8	Packaging.....	65
9	Appendix	68
9.1	Coding Schemes and Maximum Net Data Rates over Air Interface.....	68
9.2	Related Documents	69
9.3	Terms and Abbreviations	71
9.4	Safety Caution	73

Table Index

Table 1 : SIM7906A/E/G-M2 frequency bands	9
Table 2 : SIM7906G-M2 General features.....	11
Table 3 : IO parameters definition	15
Table 4 : IO parameters definition.....	16
Table 5 : Pin description	16
Table 6 : Pin description of WLAN ZIF connector interface	19
Table 7 : The description of label information.....	21
Table 8 : VBAT pins electronic characteristic	22
Table 9 : Recommended TVS diode list.....	23
Table 10 : Power on timing and electronic characteristic.....	27
Table 11 : Power off timing and electronic characteristic.....	28
Table 12 : RESET pin electronic characteristic.....	29
Table 13 : Definition of USB interface.....	34
Table 14 : USB interface TVS diode list	34
Table 15 : Definition of PCIe interface.....	36
Table 16 : PCIe interface recommended TVS diode list	37
Table 17 : USIM electronic characteristic in 1.8V mode (USIM_VDD=1.8V).....	38
Table 18 : USIM electronic characteristic 3.0V mode (USIM_VDD=2.85V).....	38
Table 19 : Definition of I2S interface.....	41
Table 20 : The PCM interface is multiplexing with I2S interface.....	41
Table 21 : DPR interface	42
Table 22 : CONFIG Pins.....	43
Table 23 : CONFIG interface definition	43
Table 24 : LED1# pin status.....	44
Table 25 : W_DISABLE1# pin status.....	44
Table 26 : Definition of antenna control interface.....	45
Table 27 : Definition of W_DISABLE2# pin.....	46
Table 28 : W_DISABLE2# pin status.....	46
Table 29 : Test point status	47
Table 30 : Antenna port definitions.....	49
Table 31 : SIM7906G-M2 WCDMA/LTE Operating frequencies.....	49
Table 32 : GNSS frequency	50
Table 33 : WCDMA/LTE antenna	51
Table 34 : the major specifications of the RF connector	52
Table 35 : Absolute maximum ratings.....	54
Table 36 : Recommended operating ratings.....	54
Table 37 : 1.8V Digital I/O characteristics*	54
Table 38 : Operating temperature	55
Table 39 : Operating mode Definition	56
Table 40 : SIM7906G-M2 Current consumption on VBAT Pins (VBAT=3.3V).....	58
Table 41 : Conducted Output Power	错误!未定义书签。
Table 42 : SIM7906G-M2 Conducted RF Receiving Sensitivity	60

Table 43 : The ESD performance measurement table (Temperature: 25°C, Humidity: 45%).....	62
Table 44 : The silica gel selection guide.....	64
Table 45 : Tray size	66
Table 46 : Small Carton size	66
Table 47 : Big Carton size	67
Table 48 : Coding Schemes and Maximum Net Data Rates over Air Interface	68
Table 49 : Related Documents	69
Table 50 : Terms and Abbreviations.....	71
Table 51 : Safety Caution	73

SIMCom
Confidential

Figure Index

Figure 1 : SIM7906G-M2 block diagram.....	11
Figure 2 : Top and bottom view of module (bottom side reserved ground plane for thermal).....	13
Figure 3 : Pin assignment.....	14
Figure 4 : Pin map of WLAN ZIF connector interface.....	15
Figure 5 : Dimensions of SIM7906G-M2 (Unit: mm).....	20
Figure 6 : Label information.....	21
Figure 7 : Power supply application circuit.....	23
Figure 8 : Linear regulator reference circuit.....	24
Figure 9 : Switching mode power supply reference circuit.....	24
Figure 10 : Reference power on/off circuit.....	26
Figure 11 : Power on timing sequence.....	26
Figure 12 : Power off timing sequence.....	28
Figure 13 : Reference reset circuit.....	29
Figure 14 : UART modem.....	30
Figure 15 : Reference circuit of level shift.....	30
Figure 16 : Level matching circuit with triode.....	31
Figure 17 : I2C reference circuit.....	32
Figure 18 : WoWWAN# behavior (SMS and URC report etc.).....	32
Figure 19 : WoWWAN# reference circuit.....	33
Figure 20 : USB reference circuit.....	34
Figure 21 : PCIe interface reference circuit (EP Mode).....	36
Figure 22 : USIM interface reference circuit.....	39
Figure 23 : USIM interface reference circuit with USIM_DET.....	39
Figure 24 : Audio codec diagram circuit.....	40
Figure 25 : Connection of DPR pin.....	42
Figure 26 : LED1# reference circuit.....	43
Figure 27 : Flight mode switch reference circuit.....	44
Figure 28 : W_DISABLE2#pin reference circuit.....	46
Figure 29 : Test point location.....	47
Figure 30 : Forcing USB Boot.....	47
Figure 31 : UART LOG.....	48
Figure 32 : RF connector.....	52
Figure 33 : Equipment diagram.....	63
Figure 34 : Thermal design diagram.....	64
Figure 35 : packaging diagram.....	65
Figure 36 : Tray drawing.....	65
Figure 37 : Small carton drawing.....	66
Figure 38 : Big carton drawing.....	66

1 Introduction

This document describes the electronic specifications, RF specifications, interfaces, mechanical characteristics and testing results of the SIMCom M.2 card. With the help of this document and other software application notes/user guides, users can understand and use SIM7906G-M2 to design and develop mobile and laptop applications quickly.

1.1 Product Outline

Aimed at the global market, SIM7906G-M2 supports WCDMA, LTE-TDD and LTE-FDD. SIM7906G-M2 support DL 2CA, 3CA. The supported radio frequency bands are described in the table1.

Table 1: SIM7906A/E/G-M2 frequency bands

Standard	Frequency	A:1NN0	A:1NN0	A:1NN0	E:1NN0	E:1NN0	E:1NN0	G:1NN0	G:1NN0	G:1NN0
		G0AA	G0AB	G0AC	G0AA	G0AB	G0AC	G0AA	G0AB	G0AC
WCDMA	B1				√	√	√	√	√	√
	B2	√	√	√				√	√	√
	B3				√	√	√	√	√	√
	B4	√	√	√				√	√	√
	B5	√	√	√	√	√	√	√	√	√
	B8				√	√	√	√	√	√
	B9							√	√	√
	B19							√	√	√
	FDD B1				√	√	√	√	√	√
FDD B2	√	√	√				√	√	√	
FDD B3				√	√	√	√	√	√	
FDD B4	√	√	√				√	√	√	
FDD B5	√	√	√	√	√	√	√	√	√	
FDD B7	√	√	√	√	√	√	√	√	√	
FDD B8				√	√	√	√	√	√	
FDD B12	√	√	√				√	√	√	
FDD B13	√	√	√				√	√	√	
FDD B14	√	√	√				√	√	√	
FDD B17	√	√	√				√	√	√	
FDD B18							√	√	√	
FDD B19							√	√	√	

FDD B20				√	√	√	√	√	√
FDD B25	√	√	√				√	√	√
FDD B26	√	√	√				√	√	√
FDD B28	√	√	√	√	√	√	√	√	√
FDD B29							√	√	√
FDD B30							√	√	√
FDD B32				√	√	√	√	√	√
FDD B66	√	√	√				√	√	√
TDD B38				√	√	√	√	√	√
TDD B40	√	√	√	√	√	√	√	√	√
TDD B41	√	√	√	√	√	√	√	√	√
TDD B42	√		√	√		√	√		√
TDD B43	√		√	√		√	√		√
TDD B46	√			√			√		
TDD B48	√		√	√		√	√		√
GNSS	√	√	√	√	√	√	√	√	√
Category	CAT12	CAT12	CAT12	CAT12	CAT12	CAT12	CAT12	CAT12	CAT12

NOTE

1. B29 & B32 & B46 are only for secondary component carrier
2. GNSS function is optional.

With a physical dimension of 30.0*42.0*2.3 mm, SIM7906G-M2 can meet PCI Express M.2 Specification, and can meet almost any space requirement in users' applications.

With M.2 Type 3042-S3-B, SIM7906G-M2 has almost all common interface integrated, such as USB2.0, PCIe, USIM card, UART, I2C, DRP, LED#, MAIN_ANT and AUX_ANT etc.

With all the interfaces, SIM7906G-M2 can also be utilized in the industrial handheld, machine-to-machine laptop application and especially the router.

1.2 Hardware Block Diagram

The block diagram of SIM7906G-M2 is shown as below:

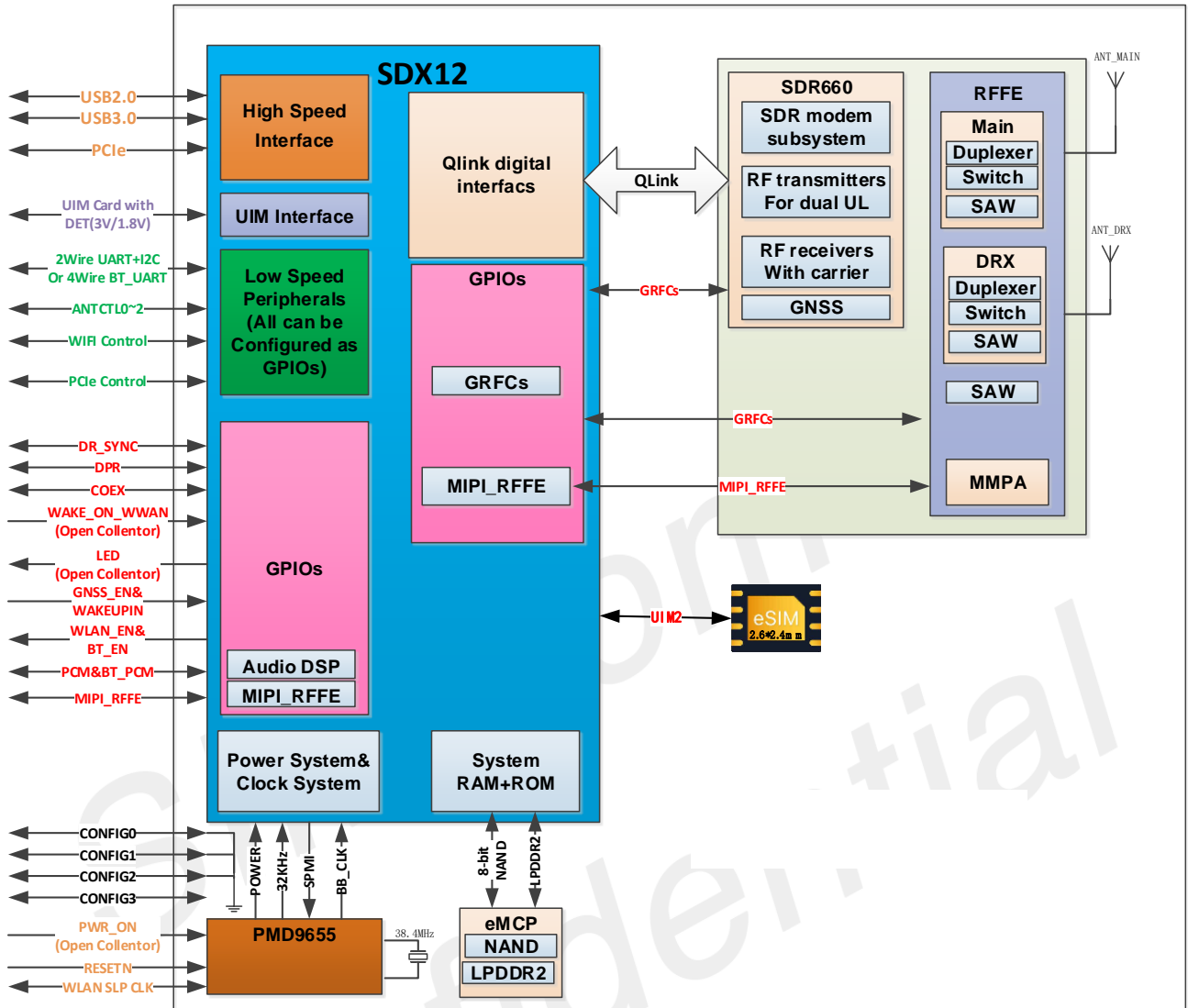

Figure 1: SIM7906G-M2 block diagram

1.3 Functional Overview

Table 2: SIM7906G-M2 General features

Feature	Implementation
Power supply	VBAT:3.135~4.4V Typical supply voltage: 3.3V
Power consumption	Power off current: <100uA Current in sleep mode : TBD (USB suspend)

Radio frequency bands	Please refer to the table 1
Transmitting power	Class 3 (23dBm±2dB) for LTE-TDD bands Class 3 (23dBm±2dB) for LTE-FDD bands Class 3 (24dBm+1/-3dB) for WCDMA bands
LTE Features	Support FDD/TDD LTE Category 12 with CA and MIMO Support uplink QPSK and 16-QAM and 64-QAM modulation Support downlink QPSK, 16-QAM and 64-QAM and 256-QAM modulation Support 1.4MHz to 60MHz (3xCA) RF bandwidth Support 2x2 MIMO in DL direction FDD: Max 600Mbps (DL)/150Mbps (UL) TDD: Max 430Mbps (DL)/90Mbps (UL)
Antenna	Main antenna (MAIN) Rx-diversity antenna & GNSS(AUX & GNSS)
SMS	MT, MO, CB, Text and PDU mode SMS storage: USIM card or ME(default) Transmission of SMS alternatively over CS or PS.
USIM interface	Dual SIM(one build-in eSIM 2.6*2.4mm),Support identity card: 1.8V/ 3V
USIM application toolkit	Support SAT class 3, GSM 11.14 Release 98 Support USAT
Phonebook management	Support phonebook types: DC,MC,RC,SM,ME,FD,ON,LD,EN
PCIe interface	<ul style="list-style-type: none"> ● Compliant with the PCI Express Base 2.0 Specification, Revision 1.0. ● Dual mode PCIe controller, working as Root Complex or Endpoint ● Support PCI Express Gen1 2.5Gb/s raw bandwidth ● Support link width x1 ● Embedded DMA engine with up to 250MB/s throughout ● AXI Master/Slave interface for inbound/outbound data transfer
UART interface	<ul style="list-style-type: none"> ● Baud rate: 300bps to 921600bps(default:115200bps) ● Can be used as the AT commands or data stream channel ● Multiplex ability according to GSM 07.10 Multiplexer Protocol
I2C interface	<ul style="list-style-type: none"> ● Apply to the "I2C Specification, version 3.0" ● Clock up to 400Kbps
USB	One USB 3.0 SuperSpeed and high-speed (for backward compatibility)
Firmware upgrade	Firmware upgrade over USB interface
Physical characteristics	Size:30*42*2.3mm Weight: 5.8g
Temperature range	Normal operation temperature: -30°C to +70°C 3GPP compliant Non operation temperature: -40°C to +85°C* Storage temperature -40°C to +90°C 72 hours

NOTE

Module is able to make and receive voice calls, data calls, SMS and make GPRS/UMTS/HSPA+/LTE traffic in -40°C ~ +85°C. The performance will be reduced slightly from the 3GPP specifications if the temperature is outside the normal operating temperature range and still within the extended operating temperature range.

2 Package Information

2.1 Top and Bottom View of Module



Figure 2: Top and bottom view of module (bottom side reserved ground plane for thermal)

NOTE

The above is the design effect drawing of the module for reference, and the actual appearance shall prevail in kind.

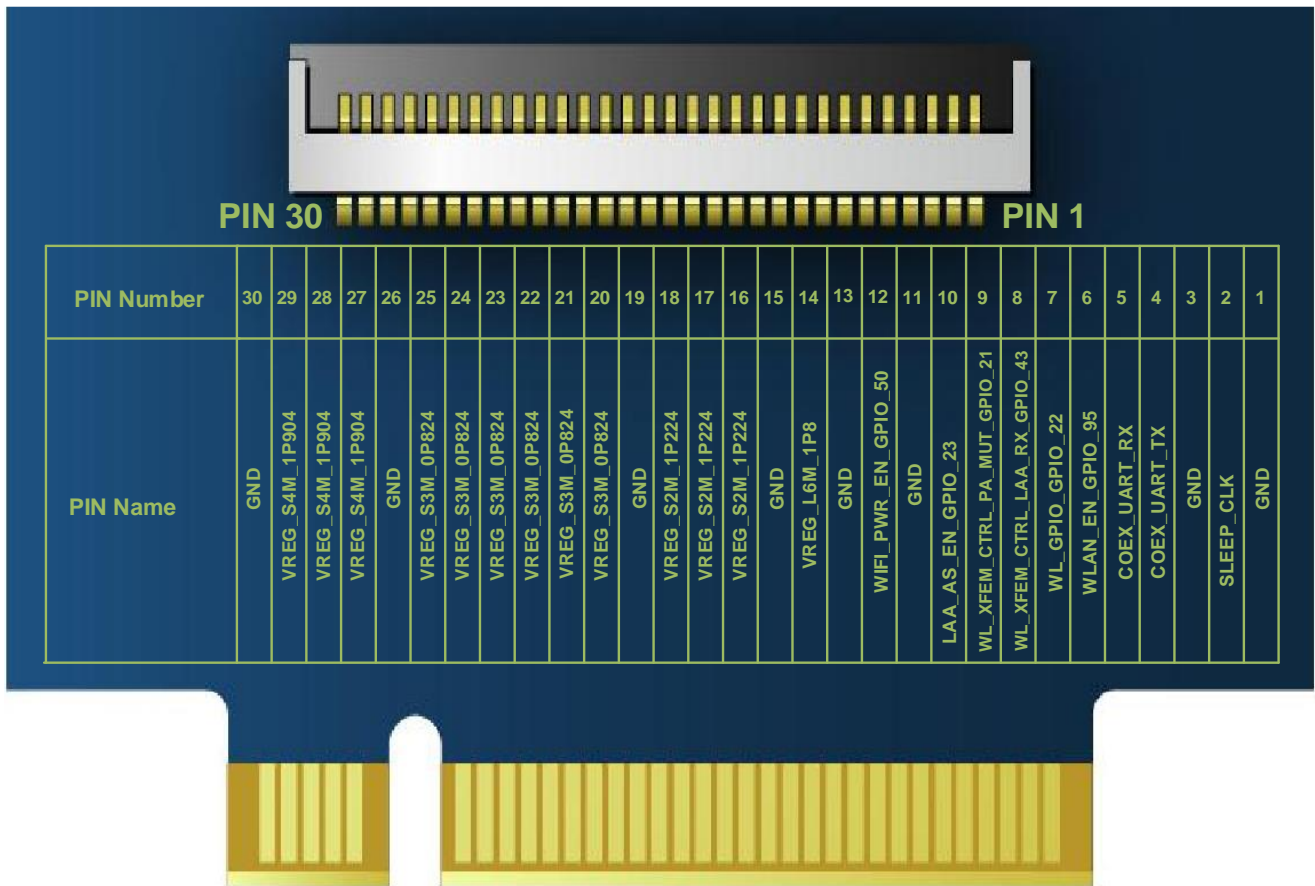

Figure 4: Pin map of WLAN ZIF connector interface

2.3 Pin Description

Table 3: IO parameters definition

Pin type	Description
PI	Power input
PO	Power output
AI	Analog input
AIO	Analog input/output
DIO	Bidirectional digital input /output
DI	Digital input
DO	Digital output
DOH	Digital output with high level
DOL	Digital output with low level
PU	Pull up
PD	Pull down
OD	Open Drain
OC	Open collector

Table 4: IO parameters definition

Voltage domain	Parameter		Min	Typ	Max
P3	VDD_P3=1.8V				
	VOH	High level output	1.35V	-	1.8V
	VOL	Low level output	0V	-	0.45V
	VIH	High level input	1.2V	1.8V	2.1V
	VIL	Low level input	-0.3V	-	0.6V
	Rp	Pull up/down resistor	20K ohm	-	60K ohm
P4	VDD_P4=1.8V				
	VOH	High level output	1.44V	-	1.8V
	VOL	Low level output	0V	-	0.4V
	VIH	High level input	1.26V	1.8V	2.1V
	VIL	Low level input	-0.3V	-	0.36V
	Rp	Pull up/down resistor	10K ohm	-	100K ohm
	VDD_P4=2.85V				
	VOH	High level output	2.28V	-	2.85V
	VOL	Low level output	0V	-	0.4V
	VIH	High level input	2.0V	-	3.15V
	VIL	Low level input	-0.3V	-	0.57V
	Rp	Pull up/down resistor	10K ohm	-	100K ohm
P5	VDD_P5=2.85V				
	VOH	High level output	2.28V	-	2.85V
	VOL	Low level output	0V	-	0.4V
	VIH	High level input	2.0V	-	3.15V
	VIL	Low level input	-0.3V	-	0.57V
	Rp	Pull up/down resistor	10K ohm	-	100K ohm

Table 5: Pin description

Pin name	Pin no.	Electrical description	Description	Comment
Power supply				
VBAT	2,4,70,72,74	PI	Power supply Range: 3.135~4.4V Typical: 3.3V	These pins should be connected together to withstand sufficient current
GND	3,5,11,27,33,39,45,51,57,		Ground	

	71,73				
System control					
FULL_CARD_POWER_OFF#	6		DI,PD	High level: the module power on Low level: the module power off	It's 3.3V tolerant but can be driven by either 1.8V or 3.3V GPIO
RESET#	67	P3	DI,PU	System reset control input Active low	RESET# has been pulled up to 1.8V internally
W_DISABLE1#	8		DI	WWAN RF disable Active low	3.3V tolerant but can be driven by either 1.8V or 3.3V GPIO
W_DISABLE2#	26		DI	W_DISABLE2# GNSS disable Active low	3.3V tolerant but can be driven by either 1.8V or 3.3V GPIO
WoWWAN#	23		OD	Wake on the host Active low	
Configuration pins					
CONFIG_0	21		GND	Connected to ground internally	The module is configured as the WWAN USB3.0 interface type
CONFIG_1	69		GND	Connected to ground internally	
CONFIG_2	75		GND	Connected to ground internally	
CONFIG_3	1		NC	Not connected	
USB2.0/USB3.0					
USB_D+	7		AIO	Differential USB bi-directional data positive	Main communication interface USB3.0 data rate up to 10Gbps USB2.0 data rate up to 480Mbps
USB_D-	9		AIO	Differential USB bi-directional data negative	
USB3.0_Tx-	29		AO	USB3.0 transmit data negative	
USB3.0_Tx+	31		AO	USB3.0 transmit data positive	
USB3.0_Rx-	35		AI	USB3.0 receive data negative	
USB3.0_Rx+	37		AI	USB3.0 receive data positive	
PCIe interface					
PETn0	41		AO	PCIe transmit data negative	Support One port; PCIe Gen 2 (PCIe Gen 1 compatible) If unused, please keep open
PETp0	43		AO	PCIe transmit data positive	
PERn0	47		AI	PCIe receive data negative	
PERp0	49		AI	PCIe receive data positive	
REFCLKN	53		AIO	PCIe reference clock negative	
REFCLKP	55		AIO	PCIe reference clock positive	
PCIe assistant interface					
PERST#	50		DI	PCIe reset signal Active low	VBAT~3.3V voltage domain, CLKREQ# and PEWAKE# required pull up external,
CLKREQ#	52		DIO	PCIe reference clock request signal Active low	

PEWAKE#	54		DIO	PCIe wake up control Active low	Default as EP mode, If unused, please keep open
(U)SIM interface					
(U)SIM1_PWR	36		PO	Power supply for (U)SIM1 card	
(U)SIM1_DATA	34	P4	DIO	(U)SIM1 card data, which has been pulled up to (U)SIM1_VDD via a 20KR resistor internally	1.8/3.0V voltage domain, (U)SIM interfaces should be protected against ESD, If unused, please keep open.
(U)SIM1_CLK	32	P4	DO	(U)SIM1 clock signal	
(U)SIM1_RESET	30	P4	DO	(U)SIM1 reset control	
(U)SIM1_DET	66	P3	DI	(U)SIM1 card detect, which has been pulled up to VDD_P3 via a 470KR resistor internally	
(U)SIM2_PWR	48		PO	Power supply for (U)SIM2 card	
(U)SIM2_DATA	42	P5	DIO	(U)SIM2 card data, which has been pulled up to (U)SIM2_VDD via a 20KR resistor internally	The eSIM has been reserved internal. 1.8/3.0V voltage domain, (U)SIM interfaces should be protected against ESD, If unused, please keep open
(U)SIM2_CLK	44	P5	DO	(U)SIM2 clock signal	
(U)SIM2_RESET	46	P5	DO	(U)SIM2 reset control	
(U)SIM2_DET	40	P3	DI	(U)SIM2 card detect, which has been pulled up to VDD_P3 via a 470KR resistor internally	
Antenna control interface²					
ANTCTL0	59	P3	DO	Antenna tuner control0	1.8V voltage domain. If unused, please keep open
ANTCTL1	61	P3	DO	Antenna tuner control1	
ANTCTL 2	63	P3	DO	Antenna tuner control2	
ANTCTL3 ² (DR_SYNC)	65	P3	DO	Antenna tuner control3 (Dead reckoning synchronization signal)	
RFFE_SDATA	58	P3	DIO	Antenna tuner MIPI DATA	
RFFE_SCLK	56	P3	DO	Antenna tuner MIPI CLK	
I2S interface					
I2S_CLK	20	P3	DO	I2S clock output	1.8V voltage domain, also can be used as PCM interface, If need audio function, please contact SIMCom support teams. If unused, please keep open.
ANT_TUNNER_ CFG (I2S_RX) ³	22	P3	DI	ANT_TUNNER_CFG_1.8V (I2S data input)	
TUNER_VDD (I2S_TX) ³	24	P3	DO	Tuner_VDD_1.8V (I2S data output)	
I2S_WA ³			DO	I2S word alignment select (L/R)	
DPR2 ^{3*}	28	P3	DI	DPR (Dynamic Power Reduction) signal is used for SAR (Specific Absorption Rate) sensor interrupt input	

I2S_MCLK	60	P3	DO	I2S master clock	
I2C interface					
I2C_SDA	68	P3	DIO	I2C data signal	1.8V voltage domain, Internal pulled up to 1.8V. If unused, please keep open
I2C_SCL	38	P3	DO	I2C clock signal	
Coex interface⁴					
COEX1* (UART_TX*)	64	P3	DO	SIM7906G-M2 hardware configures as coexistence signal function by default	If need normal communication UART(AT command), please contact SIMCom support teams
COEX2* (UART_RX*)	62	P3	DI		
Other pins					
LED1#	10		OD	The module status indicator via LED devices Active low	
DPR1*	25	P3	DI	DPR (Dynamic Power Reduction) signal is used for SAR (Specific Absorption Rate) sensor interrupt input	
Notch					
Notch	12, 13, 14, 15, 16, 17, 18, 19			Notch	

NOTE

1. "*" means under development.
2. The RFFE signals are multiplexed with ANTCTL3 and DR_SYNC.
3. SIM7906G-M2 hardware configures as DPR2、Tuner_VDD_1.8V and ANT_TUNNER_CFG output function by default.If need I2S data, please contact SIMCom support teams.
4. SIM7906G-M2 interface the pin of 62 and 64 hardware support COEX_UART function by default.

Table 6: Pin description of WLAN ZIF connector interface

Pin name	PIN no.	Electrical description		Discription
SLEEP_CLK	2	P3	DO	Sleep clock output for W80 only
COEX_UART_TX	4	P3	DO	LTE&WLAN coexistence data transmit
COEX_UART_RX	5	P3	DI	LTE&WLAN coexistence data receive
WL_EN_GPIO_52	6	P3	DO	W80 RF coexistence signals
WL_GPIO_GPIO_94	7	P3	DO	
WL_XFEM_CTRL_LAA_RX_GPIO_26	8	P3	DO	
WL_XFEM_CTRL_PA_MUT_GPIO_41	9	P3	DO	

LAA_AS_EN_GPIO_40	10	P3	DO	
WL_SW_CTRL	12	P3	DO	
VREG_L6E_1P8	14		PO	Output power supply for W80 only
VREG_S2E_1P224	16,17, 18		PO	Output power supply for W80 only
VREG_S3E_0P824	20,21, 22,23, 24,25		PO	Output power supply for W80 only
VREG_S4E_1P904	27,28, 29		PO	Output power supply for W80 only
GNG	1,3,11, 13,15, 19,26, 30			Ground

2.4 Package Dimensions

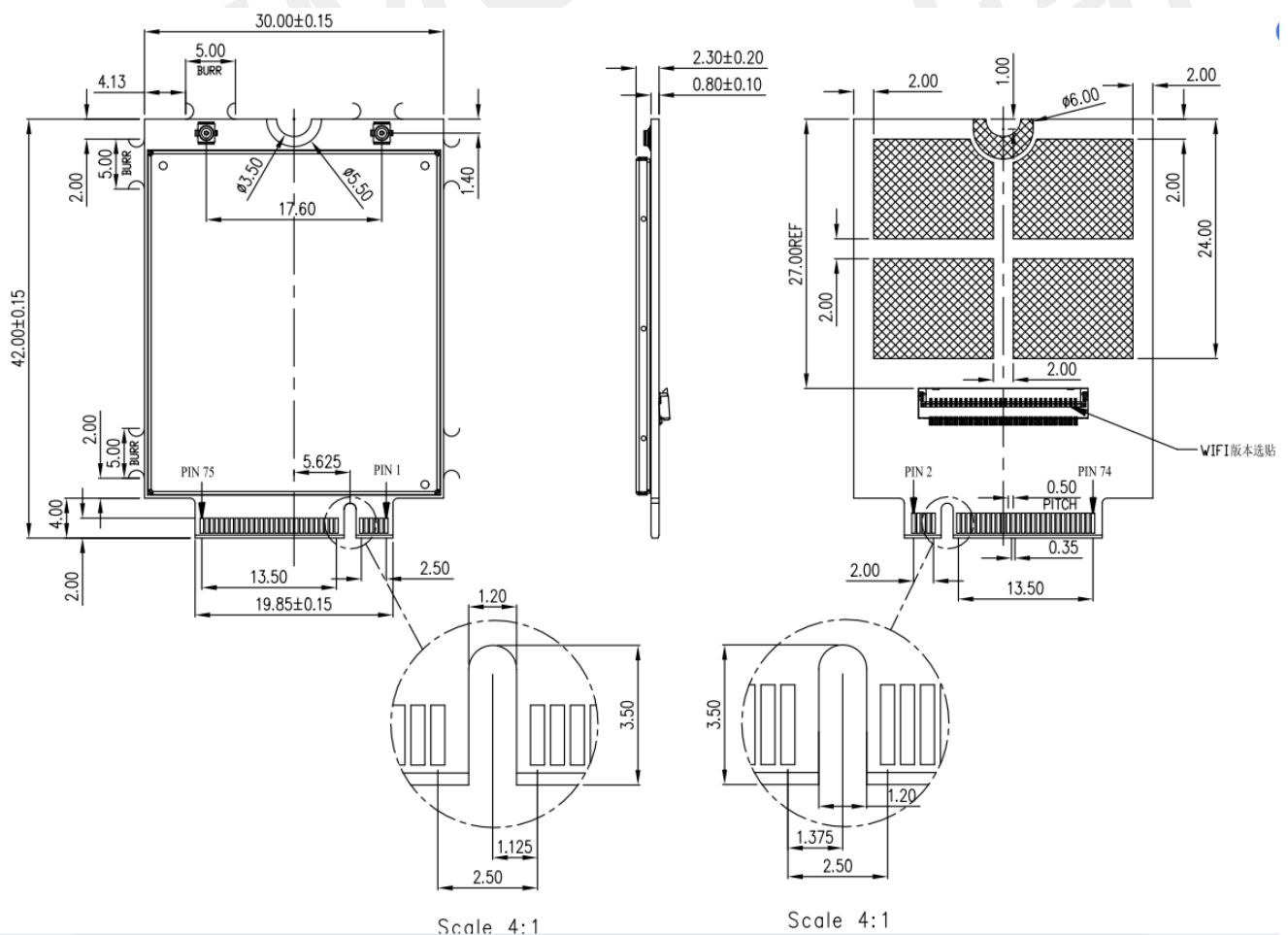

Figure 5: Dimensions of SIM7906G-M2 (Unit: mm)

2.5 Label information

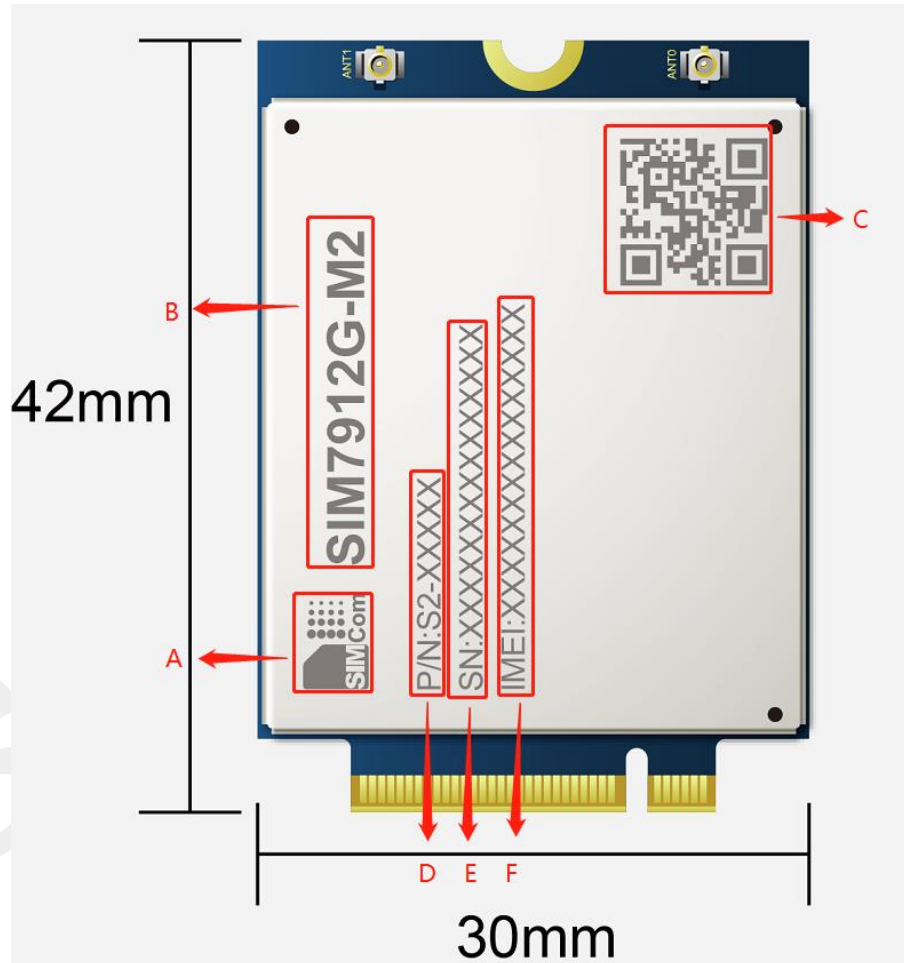

Figure 6: Label information

Table 7: The description of label information

No.	Description
A	SIMCom logo
B	Project name
C	QR code
D	Module part number
E	Serial number
F	International mobile equipment identity

3 Interface Application

3.1 Power Supply

The recommended power supply of SIM7906G-M2 is 3.3V and the voltage ranges from 3.135 V to 4.4 V. The SIM7906G-M2 has 5 power pins and 11 ground pins, to ensure the SIM7906G-M2 card works normally, all the pins must be connected. The connector pin is defined to support 500mA current per pin continuously.

Table 8: VBAT pins electronic characteristic

Symbol	Description	Min.	Typ.	Max.	Unit
VBAT	Module power voltage.	3.135	3.3	4.4	V
I_{VBAT(peak)}	Module power peak current in normal mode.	-	1.0	2.0	A
I_{VBAT(power-off)}	Module power current in power off mode.	50	80	100	uA

3.1.1 Power Supply Design Guide

Make sure that the voltage on the VBAT pins will never drop below 3.135V, even during a transmit event, when current consumption may rise up to 1.0A. If the voltage drops below 3.135V, the module might be powered off automatically.

NOTE

Be sure the power supply for VBAT pins can support more than 1.0A, using a total of more than 330uF capacitors is recommended, in order to avoid the voltage dropping to lower than 3.135V.

Some multi-layer ceramic chip (MLCC) capacitors (0.1/1uF) with low ESR in high frequency band can be used for EMC.

These capacitors should be put as close as possible to VBAT pads. Also, users should keep VBAT trace on circuit board wider than 1.0 mm to minimize PCB trace impedance. The following figure shows the recommended circuit.

If the VBAT generated by a switch mode power supply, it is suggested to add a bead to suppress the Interference. Recommend part of FB101 is BLM21PG300SN1D or MPZ2012S221A.

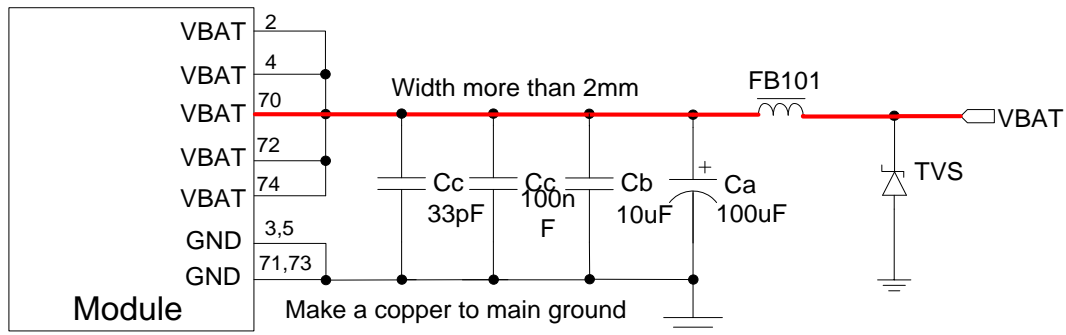

Figure 7: Power supply application circuit

NOTE

The test condition: The voltage of power supply for VBAT is 3.3V, Ca is a 100 μ F tantalum capacitor (ESR=0.7 Ω).

PIN3,5,71,73 are the main return current path of module, these pins should be coppered by a ground plane to main ground.

All other GND pins also need connect to ground.

In addition, in order to guard for over voltage protection, it is suggested to use a TVS diode to protect the M.2 card. TVS diode should be placed near VBAT pins.

Table 9: Recommended TVS diode list

No.	Manufacturer	Part Number	VRWM	Package
1	JCET	ESDBW5V0A1	5V	DFN1006-2L
2	WAYON	WS05DPF-B	5V	DFN1006-2L
3	WILL	ESD5611N	5V	DFN1006-2L
4	WILL	ESD56151W05	5V	SOD-323

3.1.2 Recommended Power Supply Circuit

It is recommended that a switching mode power supply or a linear regulator power supply is used. It is important to make sure that all the components used in the power supply circuit can resist the current which could be more than 1A.

The following figure shows the linear regulator reference circuit with 5V input and 3.3V output.

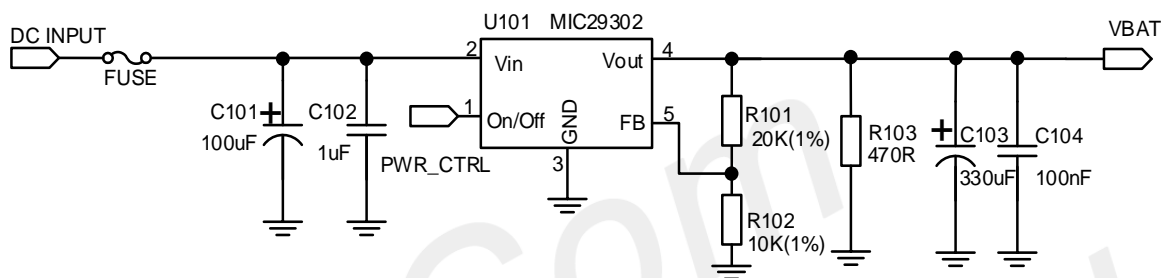

Figure 8: Linear regulator reference circuit

If there is a high dropout between input and VBAT, or the efficiency is extremely important, then a switching mode power supply will be preferable. The following figure shows the switching mode power supply reference circuit with 12V input and 3.3V output.

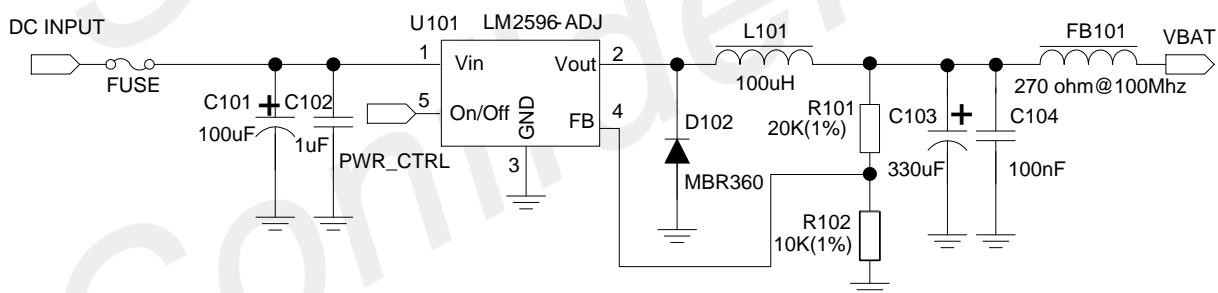

Figure 9: Switching mode power supply reference circuit

NOTE

The Switching Mode power supply solution for VBAT must be chosen carefully against Electro Magnetic Interference and ripple current from depraving RF performance.
PWR_CTRL must connect to host in case that the module system crash.

3.1.3 Voltage Monitor

To monitor the VBAT voltage, the AT command “AT+CBC” can be used.

For monitoring the VBAT voltage outside or within a special range, the AT command “AT+CVALARM” can be used to enable the Over-voltage warning function.

If users need to power off module when the VBAT voltage is out of a range, the AT command “AT+CPMVT” can be used to enable over-voltage power-off function.

NOTE

Over-voltage warning function and over-voltage power-off function are disabled by default. For more information about these AT commands, please refer to [Document \[1\]](#).

The module will power on automatically after the under-voltage power off procedure if the Full_Card_Power_Off# signal keeps at high level.

3.2 Full_Card_Power_Off#

Module can be powered on by pulling the Full_Card_Power_Off# pin up to high level through GPIO, which is 3.3V tolerant.

Full_Card_Power_Off# signal is an active **low** input signal and will turn the module on when asserted high (≥ 1.7 V) and will force the module to shut down when asserted low (≤ 0.2 V). This pin is 3.3V tolerant and can be driven by either 1.8V or 3.3V GPIO and has been pulled down internal.

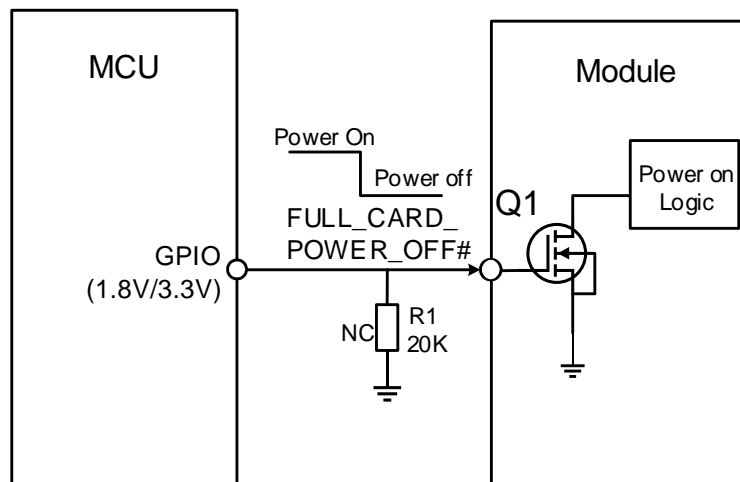

Figure 10: Reference power on/off circuit

NOTE

Module could be automatically power on by connecting Full_Card_Power_Off# pin to VBAT via 0R resistor directly.

3.2.1 Power on

The power-on scenarios are illustrated in the following figure.

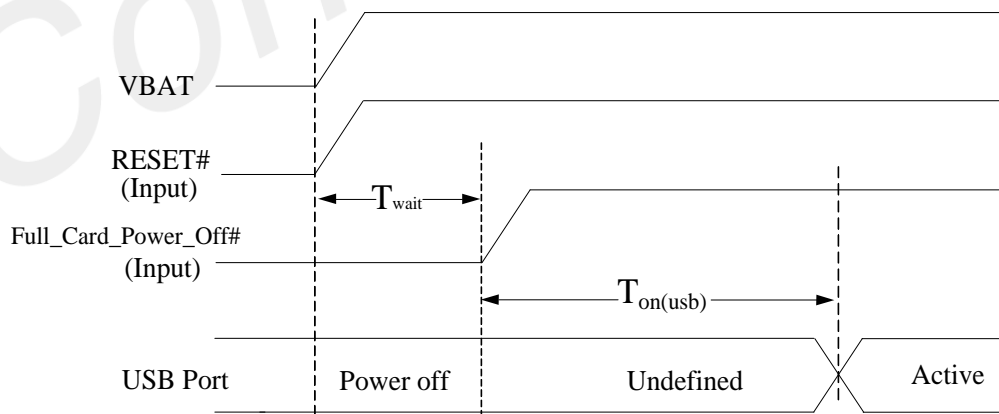

Figure 11: Power on timing sequence

Table 10: Power on timing and electronic characteristic

Symbol	Parameter	Min.	Typ.	Max.	Unit
T _{wait}	The time which is used to wait the VBAT to be stable.	100	-	-	ms
T _{on(usb)}	The time from power-on issue to USB port ready	-	TBD	50	s
V _{IH}	Input high level voltage on Full_Card_Power_Off# pin	1.0	1.8	4.4	V
V _{IL}	Input low level voltage on Full_Card_Power_Off# pin	-0.3	0	0.2	V

3.2.2 Power off

The following conditions could make the module power off.

- Condition 1: Power off module by holding the Full_Card_Power_Off# pin to a low level.
- Condition 2: Power off module by removing the VBAT.
- Condition 3: Power off module by AT command "AT+CPOF".
- Condition 4: Over-voltage or under-voltage automatic power off.
- Condition 5: Over-temperature or under-temperature automatic power off.

NOTE

The over-temperature and over-voltage function is disabled by default.

If the temperature is outside the range of -30~+70℃, some warnings will be reported via AT port. If the temperature is outside the range of -40~+85℃, module will be powered off automatically. (if the function is enabled)

The module will power on automatically after the condition 3 ~ 4 power off procedure if the Full_Card_Power_Off# signal keeps at high level.

These procedures under condition 1~3 will make the M.2 card disconnect from the network and allow the software to enter a safe state, and save data before the card be powered off completely.

The power off scenario by pulling down the Full_Card_Power_Off# pin is illustrated in the following figure.

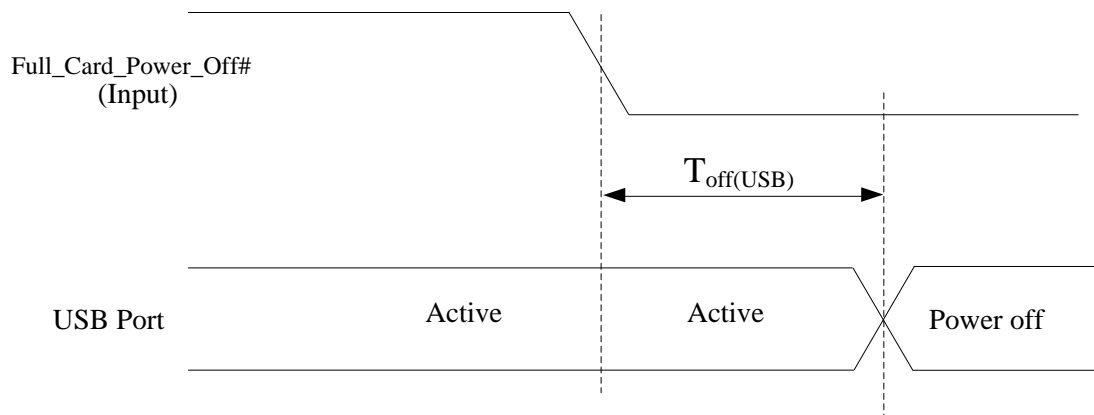

Figure 12: Power off timing sequence

Table 11: Power off timing and electronic characteristic

Symbol	Parameter	Time value			Unit
		Min.	Typ.	Max.	
$T_{off(usb)}$	The time from power-off issue to USB port off	-	TBD	20	s

3.3 Reset Function

Module can be reset by pulling the RESET# pin down to ground.

NOTE

This function is only used as an emergency reset, when both AT command “AT+CPOF” and the Full_Card_Power_Off# pin have lost efficacy.

The RESET# need a pull up with a resistor to 1.8V or 3.3V, it is strongly recommended to put a100pF capacitor and an ESD protection diode close to the RESET# pin. Please refer to the following figure for the recommended reference circuit.

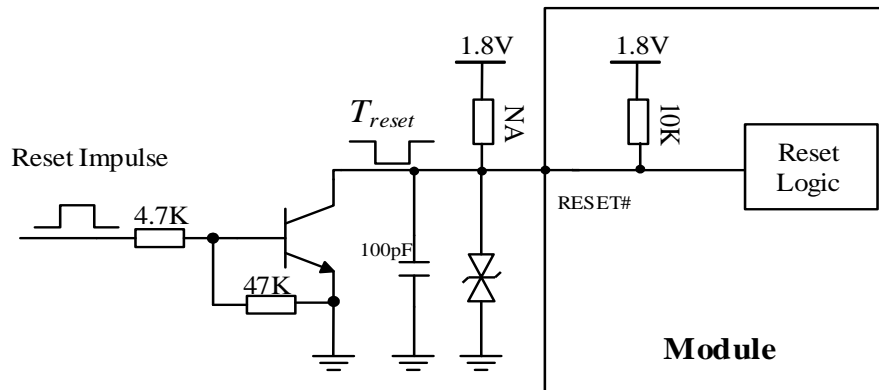

Figure 13: Reference reset circuit

Table 12: RESET pin electronic characteristic

Symbol	Description	Min.	Typ.	Max.	Unit
T_{reset}	The active low level impulse time on RESET_N pin to reset module	250	-	600	ms
V_{IH}	Input high level voltage	1.2	-	1.9	V
V_{IL}	Input low level voltage	0	-	0.4	V

3.4 UART interface

Module provides a 2-wire UART (universal asynchronous serial transmission) interface as DCE (Data Communication Equipment). AT commands and data transmission can be performed through UART interface.

The following figures show the reference design.

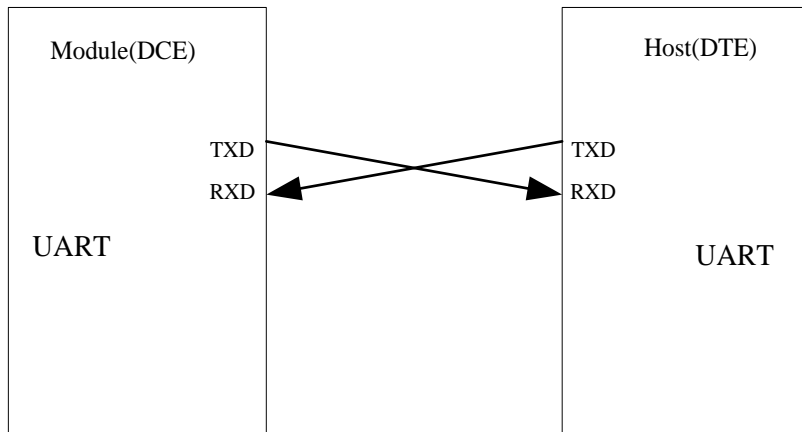

Figure 14: UART modem

The module UART is 1.8V voltage interface. If user's UART application circuit is 3.3V voltage interface, the level shifter circuits should be used for voltage matching. The TXB0102RGYR provided by Texas Instruments is recommended. The following figure shows the voltage matching reference design.

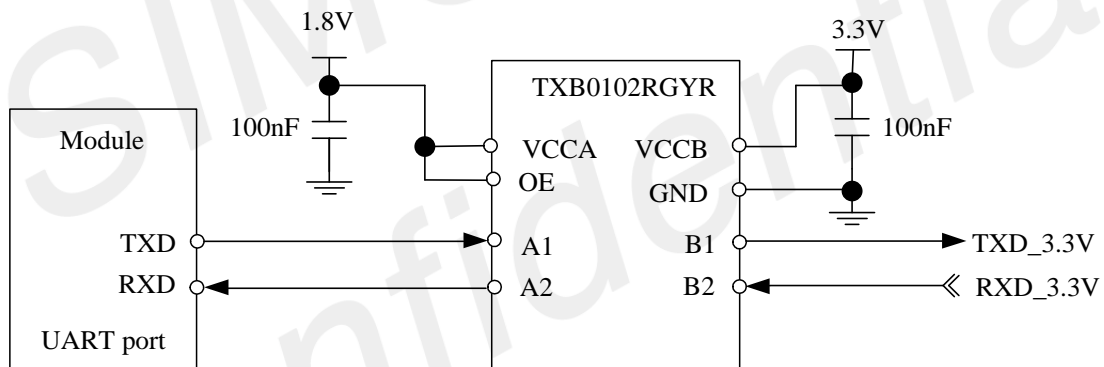

Figure 15: Reference circuit of level shift

Customers can use another level shifter circuits as follow.

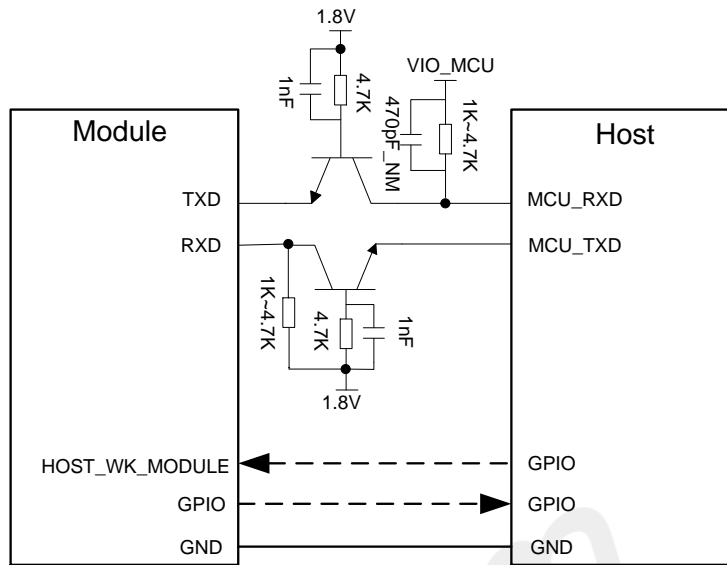

Figure 16: Level matching circuit with triode

NOTE

User need to use high speed transistors such as MMBT3904, or use NMOS such as 2SK3541T2L. Module supports the following baud rates: 300, 600, 1200, 2400, 4800, 9600, 19200, 38400, 57600, 115200, 230400, 460800, 921600. The default band rate is 115200bps. Dotted line signal should refer to the TXD and RXD circuit. HOST_WK_MODULE function please refer chapter 3.17.

3.5 I2C Interface

Module provides an I2C interface compatible with I2C specification, version 3.0, with clock rate up to 400 kbps. Its operation voltage is 1.8V.

The following figure shows the I2C bus reference design.

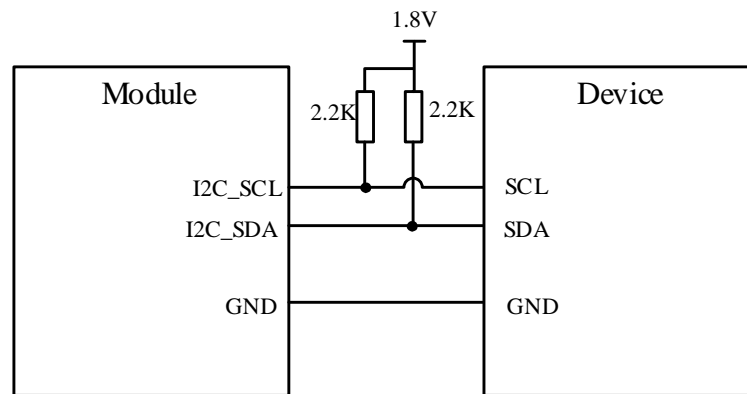

Figure 17: I2C reference circuit

NOTE

I2C_SDA and I2C_SCL have no pull-up resistors in module. So, 2 external pull up resistors are necessary in application circuit.

For more details about AT commands please refer to document [1].

3.6 WoWWAN#

The WoWWAN# pin is an open drain signal which can be used as an interrupt signal to the host. Normally it will keep high logic level until certain conditions such as receiving SMS, voice call (CSD, video) or URC reporting, then WoWWAN# will change to low logic level to inform the host (client PC), the pulse time is 1 second.

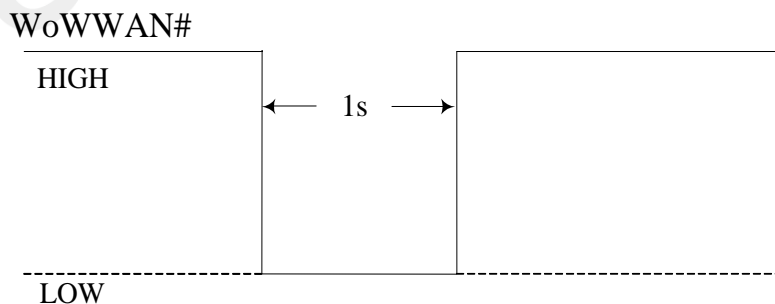

Figure 18: WoWWAN# behavior (SMS and URC report etc.)

WoWWAN# Reference circuit is recommended in the following figure.

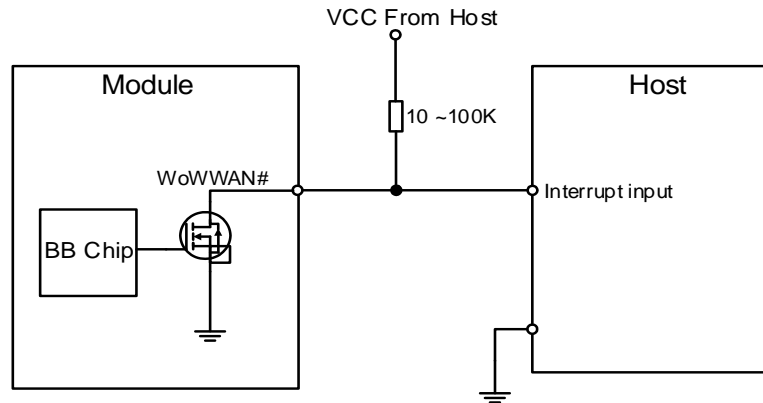

Figure 19: WoWWAN# reference circuit

3.7 USB Interface

SIM7902G-M2 supports one USB interface which complies with the USB3.0 and 2.0 specifications. Customers can choose USB3.0 or USB2.0 for their needs. USB 3.0 data rate up to 10Gbps.

The USB interface is used for AT command communication, data transmission, GNSS NMEA output, firmware upgrade and software debugging.

The module supports USB suspend and resume mechanism which can save power consumption. If there is no data transmission on the USB bus, the module will enter suspend mode automatically.

The following figure is the USB reference circuit.

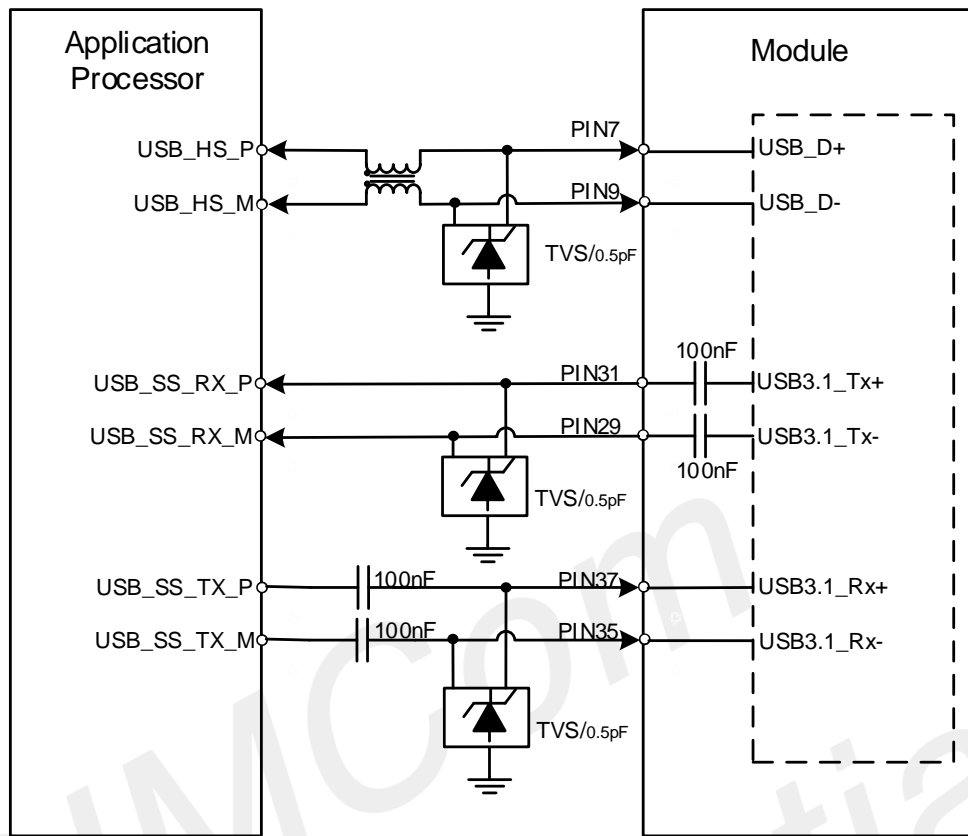

Figure 20: USB reference circuit

Table 13: Definition of USB interface

Pin name	Pin no.	Electrical description	Description	Comment
USB_D+	7	AIO	Differential USB bi-directional data positive	USB3.0 data rate up to 10Gbps USB2.0 data rate up to 480Mbps
USB_D-	9	AIO	Differential USB bi-directional data negative	
USB3.0_Tx-	29	AO	USB3.0 transmit data negative	
USB3.0_Tx+	31	AO	USB3.0 transmit data positive	
USB3.0_Rx-	35	AI	USB3.0 receive data negative	
USB3.0_Rx+	37	AI	USB3.0 receive data positive	

Table 14: USB interface TVS diode list

No.	Manufacturer	Part number	Package
1	WILL	ESD5302N-3/TR	DFN1006-3L

USB HS D+/D- layout guidelines:

- Require differential trace impedance is $90\pm 10\% \Omega$.
- The intra-lane length mismatch of the differential signal lanes is less than 1mm.
- Gap from other signals keeps 3xline width.
- External components should be placed near the USB connector.
- Trace routes away from other sensitive signals (RF, audio, and 38.4M XO).
- The TVS diode should be placed close to the USB pins of M.2 connector.
- Maximum PCB trace length cannot exceed 100mm outside of module, the shorter trace and more better.

USB SS TX/RX layout guidelines:

- Require differential trace impedance is $90\pm 10\% \Omega$.
- The intra-lane length mismatch of the differential signal lanes is less than 500um.
- Gap from other signals keeps 4xline width.
- Gap between Rx-to-Tx keeps 4xline width.
- External components should be placed near the USB connector.
- Trace routes away from other sensitive signals (RF, especially 2.4 GHz).
- The TVS diode should be placed close to the USB pins of M.2 connector.
- Route differential pairs in the inner layers with a solid GND reference to have good impedance control and to minimize discontinuities.
- Keep isolation between the Tx pair, Rx pair, and DP/DM to avoid crosstalk.
- If core vias are used, use no more than two core vias per signal line to limit stubs.

3.8 PCIe Interface

SIM7906G-M2 supports PCIe Gen 2 (PCIe Gen 1 compatible) , and can be used as Root Complex or Endpoint mode. CLKREQ# and PEWAKE# needs pull up to 3.3V by 100K resesitor in customers' design.

The following figure is the PCIe reference circuit.

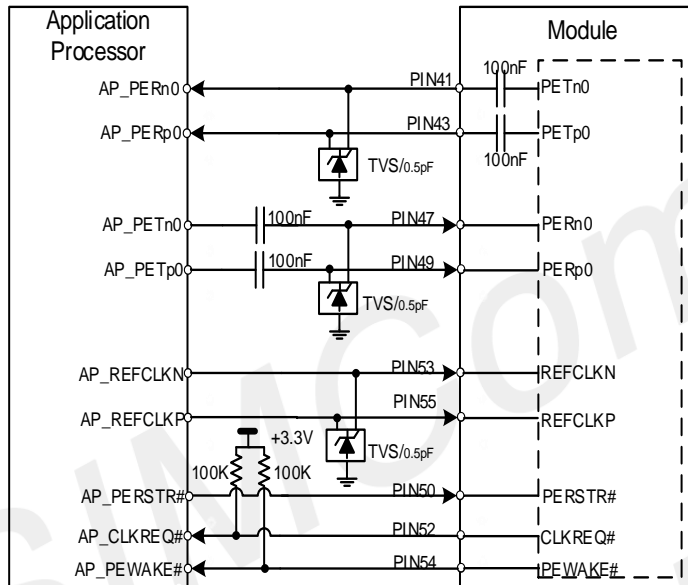

Figure 21: PCIe interface reference circuit (EP Mode)

NOTE

1. "*" means under development.
2. The AC capacitors of AP_PETn0 and AP_PETp0 should be closed to AP.
3. The voltage domain of PCIe assistant signals is VBAT~3.3V.

Table 15: Definition of PCIe interface

Pin Name	Pin No.	Electrical Description	Functional Description	Comment
PETn0	41	AIO	PCI Express Lane 0, Transmit Pair, Negative Signal 2.5GHz serial interface	
PETp0	43	AIO	PCI Express Lane 0, Transmit Pair, Positive Signal 2.5GHz serial interface	

PERn0	47	AIO	PCI Express Lane 0, Receive Pair, Negative Signal 2.5GHz Serial interface	VBAT~3.3V voltage domain, CLKREQ# and PEWAKE# required pull up external, Default as EP mode. If unused, please keep open
PERp0	49	AIO	PCI Express Lane 0, Receive Pair, Positive Signal 2.5GHz Serial interface	
REFCLKN	53	AIO	100MHz PCI Express platform reference Clock Negative signal of differential pair	
REFCLKP	55	AIO	100MHz PCI Express platform Reference Clock. Positive signal of differential pair	
PERST# ¹	50	DI	PERSTR# is a functional reset to the Add-In module active low	
CLKREQ#	52	DIO	PCIe reference clock request signal active low	
PEWAKE#	54	DIO	PCIe wake up signal active low	

NOTE

1.SIM7906G-M2 interface the pin of PCIe endpoint(EP) mode by default. Support root complex(RC) mode of the module , for more details, please contact SIMCom support teams.

Table 16: PCIe interface recommended TVS diode list

No.	Manufacturer	Part Number	Package
1	WILL	ESD5302N-3/TR	DFN1006-3L

PCIe interface layout guidelines:

- Require differential trace impedance is $90 \pm 10\% \Omega$.
- The intra-lane length mismatch of the differential signal lanes is less than 700um (5ps).
- Gap from other signals keeps 4xline width.
- Gap between Rx-to-Tx keeps 4xline width.
- Should be routed away from sensitive signals.
- The TVS diode should be placed close to the PCIe pins of M.2 connector.

3.9 USIM Interface

Module supports both 1.8V and 3.0V USIM Cards. The eSIM has been reserved internal, which is compatible with USIM2 signal, and it no assembly on the module by default.

Table 17: USIM electronic characteristic in 1.8V mode (USIM_VDD=1.8V)

Symbol	Parameter	Min.	Typ.	Max.	Unit
USIM_VDD	LDO power output voltage	1.75	1.8	1.95	V
V _{IH}	High-level input voltage	0.65*USIM_VDD	-	USIM_VDD +0.3	V
V _{IL}	Low-level input voltage	-0.3	0	0.35*USIM_VDD	V
V _{OH}	High-level output voltage	USIM_VDD -0.45	-	USIM_VDD	V
V _{OL}	Low-level output voltage	0	0	0.45	V

Table 18: USIM electronic characteristic 3.0V mode (USIM_VDD=2.85V)

Symbol	Parameter	Min.	Typ.	Max.	Unit
USIM_VDD	LDO power output voltage	2.75	2.85	3.05	V
V _{IH}	High-level input voltage	0.65*USIM_VDD	-	USIM_VDD +0.3	V
V _{IL}	Low-level input voltage	-0.3	0	0.25*USIM_VDD	V
V _{OH}	High-level output voltage	USIM_VDD -0.45	-	USIM_VDD	V
V _{OL}	Low-level output voltage	0	0	0.45	V

3.9.1 USIM Application Guide

It is recommended to use an ESD protection component such as ESDA6V1-5W6 produced by ST (www.st.com) or SMF12C produced by ON SEMI (www.onsemi.com). Note that the USIM peripheral circuit should be close to the USIM card socket. The following figure shows the 6-pin SIM card holder reference circuit.

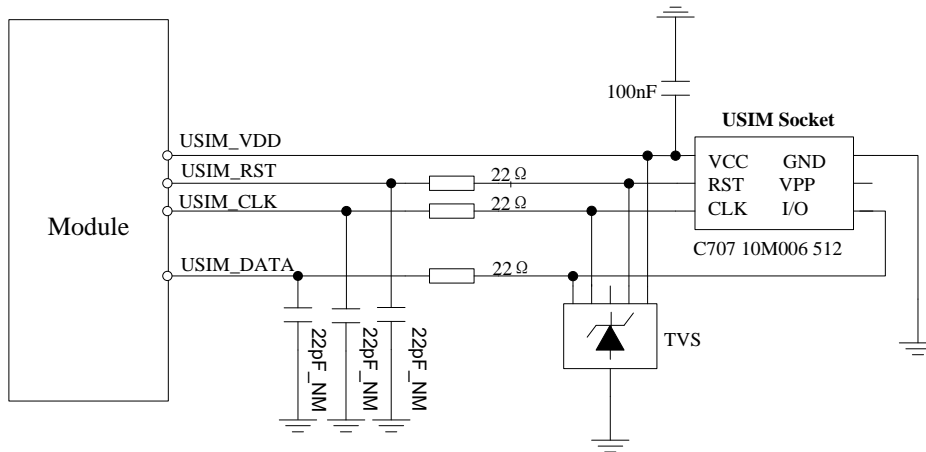

Figure 22: USIM interface reference circuit

The SIM Detect pin is used for detection of the USIM card hot plug in. User can select the 8-pin USIM card holder to implement USIM card detection function.

The following figure shows the 8-pin SIM card holder reference circuit.

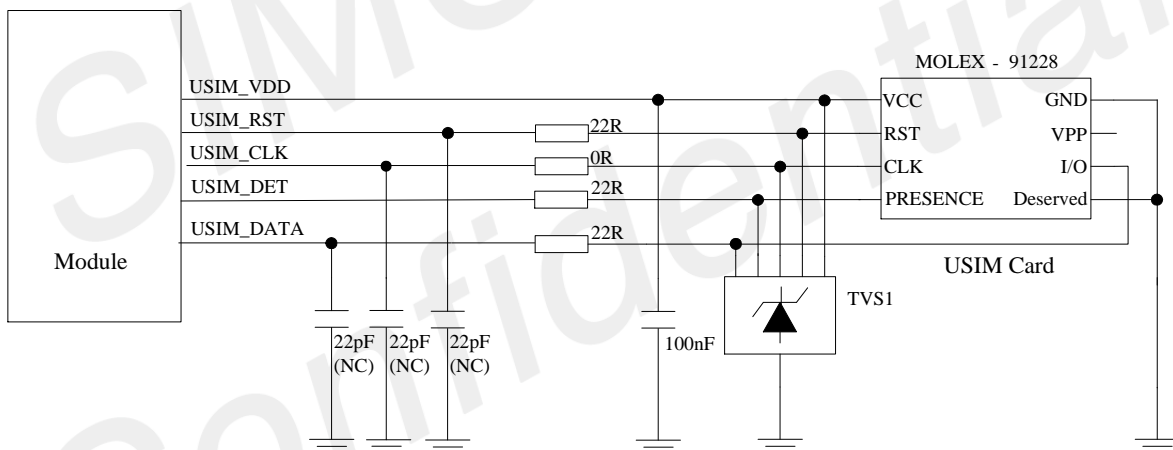

Figure 23: USIM interface reference circuit with USIM_DET

If the USIM card detection function is not used, user can keep the SIM Detect pin open.

NOTE

The eSIM has been reserved internal, which is compatible with USIM2 signal, and it is not assembled on the module by default.

This function is under development, about eSIM for details please contact SIMCom support teams.

3.9.2 USIM layout guide

SIM card circuit is susceptible, the interference may cause the SIM card failures or some other situations, so it is strongly recommended to follow these guidelines while designing:

- Make sure that the SIM card holder should be far away from the antenna while in PCB layout.
- SIM traces should keep away from RF lines, VBAT and high-speed signal lines.
- The traces should be as short as possible.
- Keep SIM holder's GND connect to main ground directly.
- Shielding the SIM card signal by ground.
- Recommended to place a 0.1~1uF capacitor on USIM_VDD line and keep close to the holder.
- The rise/fall time of USIM_CLK should not be more than 40ns.
- Add some TVS and the parasitic capacitance should not exceed 60pF.

3.10 I2S Interface

The SDX device supports two (primary and secondary) bidirectional multiple inter-IC sound (MI2S) interfaces and two (primary and secondary) PCM interfaces to support I2S/PCM devices.

The following figure is the external codec reference design circuit.

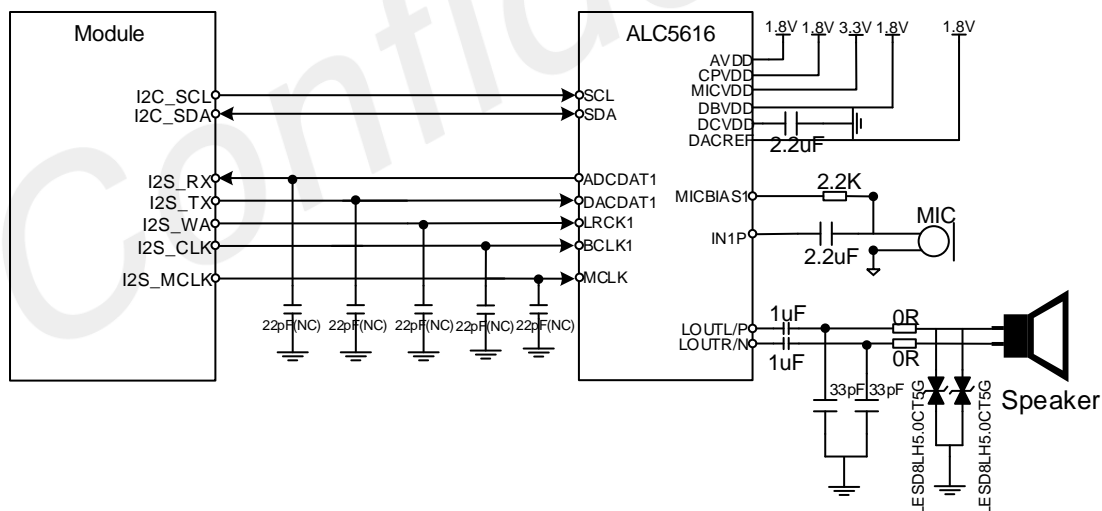

Figure 24: Audio codec diagram circuit

NOTE

- 1、 “*” The module configures as DPR2、 Tuner_VDD_1.8V and ANT_TUNNER_CFG output function on the same interfaces with PCM interfaces by default, If need PCM audio function, please contact SIMCom support teams.

Table 19: Definition of I2S interface

Pin name	Pin no.	Electrical description	Description	Comment
I2S_CLK	20	DO	I2S clock output	1.8V voltage domain, also can be used as PCM interface, If unused, please keep open
I2S_RX	22	DI	I2S data input	
I2S_TX	24	DO	I2S data output	
I2S_WA	28	DO	I2S word alignment select (L/R)	
I2S_MCLK	60	DO	I2S master clock	

The PCM interface is multiplexing with I2S interface. The default audio interface of the module is I2S.

Table 20: The PCM interface is multiplexing with I2S interface

Pin name	PCM interface
I2S_RX	PCM_DIN
I2S_TX	PCM_OUT
I2S_WA	PCM_SYNC
I2S_CLK	PCM_CLK
I2S_MCLK	-

Audio layout guidelines:

Analog input

- 0.2mm trace widths; 0.2mm spacing between other signals trace.
- Pseudo differential route for MIC.
- Isolate from noise sources, such as antenna, RF signals, SMPS, clocks, and other high speed signals.

Analog output

- Isolate from noise sources such as antenna, RF signals, SMPS, clocks, and other high speed signals.
- Speaker output signal – route as differential pair with 0.5mm trace widths.

Audio power and GND

- Recommend add magnetic bead on AVDD net reserved for debug.
- VDD cannot directly use VBAT as the power supply.
- AGND need add GND via to the main GND plane directly.

3.11 DPR

DPR (Dynamic Power Reduction) signal is used by SIM7906G-M2 to assist in meeting regulatory SAR (Specific Absorption Rate) requirements for RF exposure. The signal is provided by a host system proximity sensor to module to provide an input trigger causing a reduction in the radio transmit output power.

User can use AT command to active this function, if do not need this function, this pin can be keep floating.

Table 21: DPR interface

Pin no	Pin Name	Pin status	Function
25	DPR	Low	Max transmitting power will be reduced by set through AT command
		High	Max transmitting power will not be reduced (default)
		Floating	Max transmitting power will not be reduced
28	DPR2	DI	SAR solution: In case of HW only solution.

The proximity sensor should be controlled by host, following figure shows the connection relationship between module and sensor.

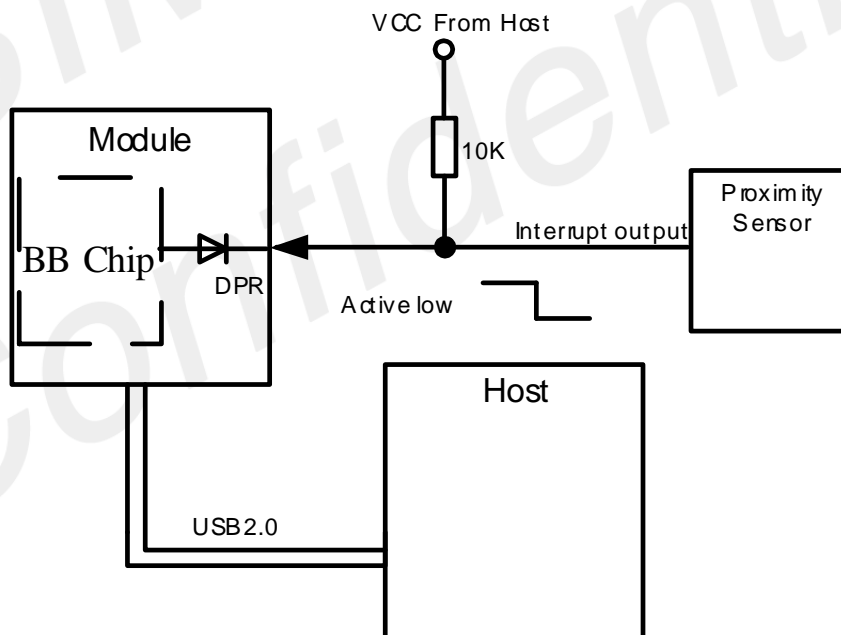

Figure 25: Connection of DPR pin

NOTE

The DPR function is under developing.

3.12 CONFIG Pins

These signals provide the means to indicate the specific configuration of the module. SIM7906G-M2 is configured as WWAN-USB3.0 .

Table 22: CONFIG Pins

Pin no	Pin Name	Description
21	CONFIG_0	Connected to GND internally.
69	CONFIG_1	Connected to GND internally.
75	CONFIG_2	Connected to GND internally.
1	CONFIG_3	No Connect internally.

In the M.2 specification, the 4 pins are defined as below:

Table 23: CONFIG interface definition

CONFIG_0 (Pin 21)	CONFIG_1 (Pin 69)	CONFIG_2 (Pin 75)	CONFIG_3 (Pin 1)	Module type and main host interface	Comments
GND	GND	GND	NC	WWAN – USB 3.0	Vendor defined

3.13 LED1#

LED1# is open drain output and is used to allow SIM7906G-M2 to provide network status via LED which will be provided by the host.

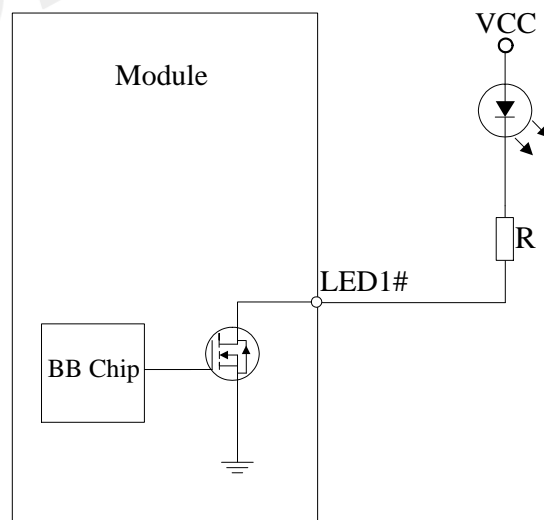

Figure 26: LED1# reference circuit

NOTE

The value of the resistor named “R” depends on the LED characteristic.

The timing sequence is as followed:

Table 24: LED1# pin status

LED1# pin status	Module status
Always On	Searching Network; Call Connect (include VOLTE, SRLTE)
200ms ON, 200ms OFF	Data Transmit; 4G registered;
800ms ON, 800ms OFF	3G registered network
OFF	Power off; Sleep

3.14 W_DISABLE1#

The W_DISABLE1# pin controls SIM7906G-M2 to enter or exit the flight mode, when the W_DISABLE1# signal is asserted to low level, all RF functions would be disabled. When the W_DISABLE1# signal is not asserted, the RF function will be active if it was not disabled by other means such as software.

Its reference circuit is shown in the following figure.

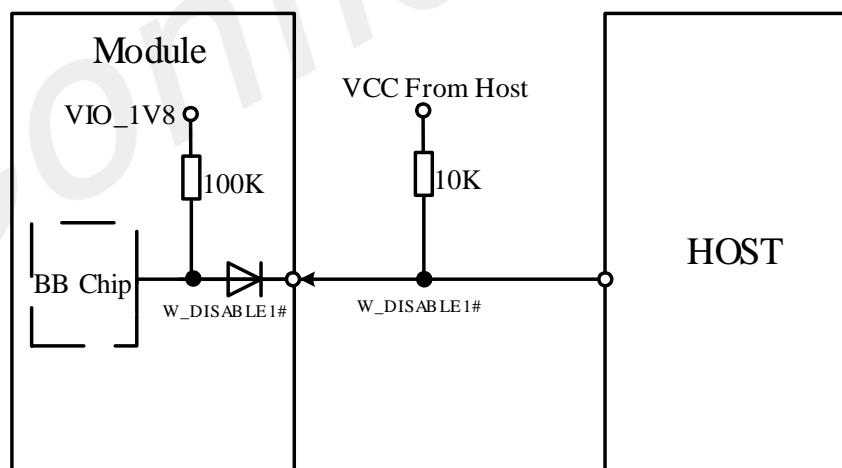

Figure 27: Flight mode switch reference circuit

W_DISABLE1# pin status as below:

Table 25: W_DISABLE1# pin status

W_DISABLE1# pin status	Module operation
Input Low Level	Flight Mode: RF is closed
Input High Level	AT+CFUN=4: RF is closed AT+CFUN=1: RF is working (default)

3.15 ANTCTRL interface

ANTCTL[0:3] are used for tunable antenna control and should be routed to an appropriate antenna control circuitry.

The following table are the definitions for antenn control interfaces.

Table 26: Definition of antenna control interface

Pin Name	Pin No.	Electrical Description	Description	Comments
ANTCTL0	59	DO	Antenna tuner control0	
ANTCTL1	61	DO	Antenna tuner control1	1.8V voltage domain. If unused, please keep open
ANTCTL 2	58	DO	Antenna tuner control2	
ANTCTL3 (DR_SYNC)	56	DO	Antenna tuner control3	

NOTE

This function is under development, for details please contact SIMCom support teams.

3.16 W_DISABLE2#

The W_DISABLE2# pin controls SIM7906G-M2 to disable the GNSS function. When the W_DISABLE2# signal is pulled to low level, the GNSS function would be disabled. The following figure shows the reference circuit of W_DISABLE2#.

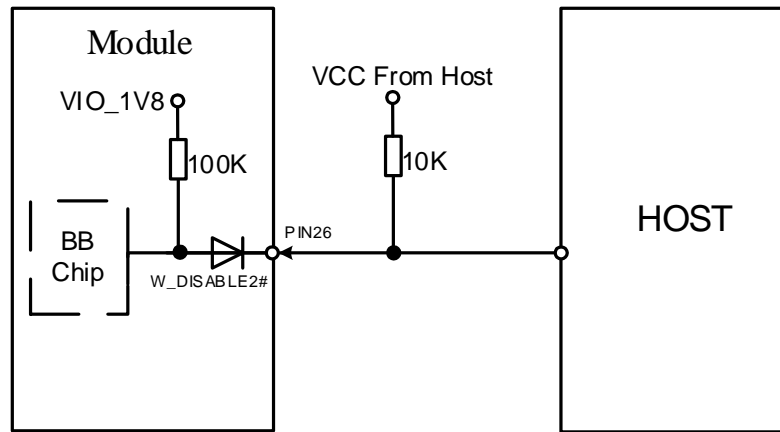

Figure 28: W_DISABLE2#pin reference circuit

Table 27: Definition of W_DISABLE2# pin

Pin name	Pin no.	Electrical description	Description	Comments
W_DISABLE2#	26	DI	GNSS disable Active low	3.3V tolerant but can be driven by either 1.8V or 3.3V GPIO

Table 28: W_DISABLE2# pin status

W_DISABLE2# pin status	Module operation
Input Low Level	GNSS function is disabled
Input High Level	AT+CGPS=0: GNSS function is disabled AT+CGPS=1: GNSS function is enabled(default)

3.17 FORCE DOWNLOAD & GET DEBUG LOG

SIM7906G-M2 reserve test points to facilitate customers to use the forced download function. At the same time, we can also read the debugging log.

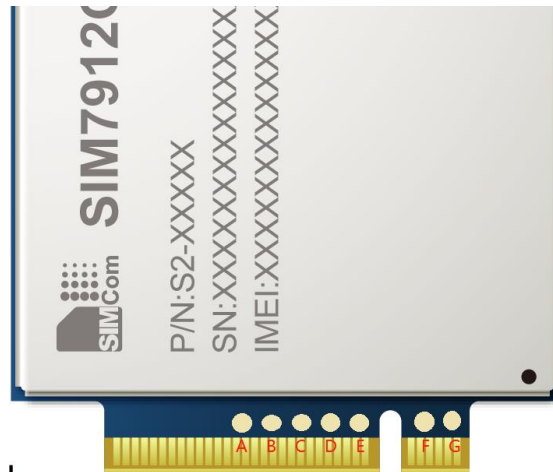

Figure 29: Test point location

Table 29: Test point status

Test point	Pin name	Electrical description	Description	Comments
A	RESET#	DI,PU	System reset control input Active low	RESET# has been pulled up to 1.8V internally
B	VOUT1.8V	DO,PU	pulled up to 1.8V internally	1.8V voltage domain
C	FORCE_USB_BOOT	DI	Connect to VOUT1.8V enter to force download function	
D	DEBUG_TX	DO	Debug UART TX	1.8V voltage domain
E	DEBUG_RX	DI	Debug UART RX	
F	USB_D-	DIO	Differential USB bi-directional data negative	
G	USB_D+	DIO	Differential USB bi-directional data positive	

3.17.1 Forcing USB Boot

During development or factory production, a boot from the USB 2.0 port can be forced by using test point of FORCED_USB_BOOT. FORCED_USB_BOOT always takes precedence, regardless of the state of the BOOT_CONFIG GPIOs or FAST_BOOT_SEL fuses. We can short circuit test points B and C of the module forces the SDX device to boot from the USB_HS port.

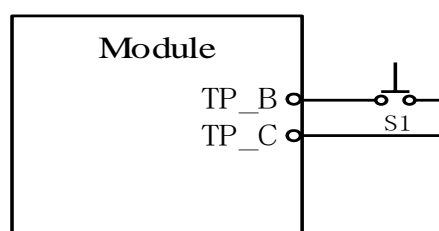

Figure 30: Forcing USB Boot

3.17.2 Get UART log

During development we need get UART LOG to analyze problems. We can obtain log on PC through serial port tool. The default band rate is 115200bps.

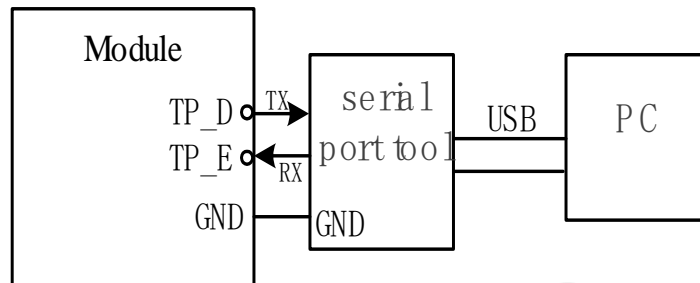

Figure 31: UART LOG

SIMCom
Confidential

4 Antenna Interfaces

SIM7906G-M2 provides two antennas for 3G/4G and GNSS. The antenna ports have an RF impedance of 50Ω.

4.1 Antenna Definitions

For detailed designs about antenna, please refer to the antenna design guide [Document \[14\]](#) “SIM7906G-M2 Antenna Port Mapping and Design Guide” in the appendix.

Table 30: Antenna port definitions

FUNCTIONS	MAIN	AUX GNSS
3G/4G LB/MHB TRX	✓	
3G/4G LB/MHB DIV		✓
GNSS		✓

4.1.1 WCDMA/LTE Operating Frequency

The following table shows WCDMA/LTE Operating frequencies

Table 31: SIM7906G-M2 WCDMA/LTE Operating frequencies

Band	Uplink (UL)	Downlink (DL)	Duplex Mode
WCDMA B1	1920 ~1980 MHz	2110 ~2170 MHz	FDD
WCDMA B2	1850 ~1910 MHz	1930 ~1990 MHz	FDD
WCDMA B3	1710 ~1785 MHz	1805 ~1880 MHz	FDD
WCDMA B4	1710 ~1755 MHz	2110 ~2155 MHz	FDD
WCDMA B5	824~849 MHz	869~894MHz	FDD
WCDMA B6	832.4~837.6 MHz	877.4~882.6MHz	FDD
WCDMA B8	880 ~915 MHz	925 ~960 MHz	FDD
WCDMA B9	1749.9 ~1784.9 MHz	1844.9 ~1879.9 MHz	FDD
WCDMA B19	830 ~845 MHz	875 ~890 MHz	FDD
LTE B1	1920 ~1980 MHz	2110 ~2170 MHz	FDD
LTE B2	1850 ~1910 MHz	1930 ~1990 MHz	FDD

LTE B3	1710 ~1785 MHz	1805 ~1880 MHz	FDD
LTE B4	1710 ~1755 MHz	2110 ~2155 MHz	FDD
LTE B5	824~849 MHz	869~894MHz	FDD
LTE B7	2500~2570MHz	2620~2690MHz	FDD
LTE B8	880 ~915 MHz	925 ~960 MHz	FDD
LTE B12	699 ~716 MHz	729 ~746 MHz	FDD
LTE B13	777 ~787 MHz	746 ~756 MHz	FDD
LTE B14	788 ~798 MHz	758 ~768 MHz	FDD
LTE B17	704 ~716 MHz	734 ~746 MHz	FDD
LTE B18	815 ~830 MHz	860 ~875 MHz	FDD
LTE B19	830 ~845 MHz	875 ~890 MHz	FDD
LTE B20	832~862MHz	791~ 821MHz	FDD
LTE B25	1850 ~1915 MHz	1930 ~1995 MHz	FDD
LTE B26	814 ~849 MHz	859 ~894 MHz	FDD
LTE B28	703~748 MHz	758~803 MHz	FDD
LTE B29	N/A	717 ~728 MHz	FDD
LTE B30	2305 ~2315 MHz	2350 ~2360 MHz	FDD
LTE B32	N/A	1452~1492MHz	FDD
LTE B38	2570 ~2620 MHz	2570 ~2620 MHz	TDD
LTE B40	2300 ~2400 MHz	2300 ~2400 MHz	TDD
LTE B41	2555 ~2655 MHz	2555 ~2655 MHz	TDD
LTE B42	3400 ~3599.9 MHz	3400 ~3599.9 MHz	TDD
LTE B43	3600 ~3799.9 MHz	3600 ~3799.9 MHz	TDD
LTE B46	5150 ~5925 MHz	5150 ~5925 MHz	LAA
LTE B48	3550 ~3700 MHz	3550 ~3700 MHz	TDD
LTE B66	1710 ~1780 MHz	2110 ~2200 MHz	FDD

NOTE

LTE-FDD B29 & B32 & B46 supports Rx only and are only for secondary component carrier.

4.1.2 GNSS Frequency

The following table shows frequency specification of GNSS antenna interface.

Table 32: GNSS frequency

Type	Frequency
GPS L1/Galileo/QZSS	1575.42±1.023MHz
GPS L5	1176.45±10.23MHz
GLONASS	1597.5~1605.8MHz
BeiDou/Compass	1561.098±2.046MHz

4.2 Antenna Installation

4.2.1 Antenna Requirements

The following table shows the requirements on 3G/4G and GNSS antennas.

Recommended Antenna Characteristics

Table 33: WCDMA/LTE antenna

Item	Requirements
Direction	Omni directional
Gain	> -3dBi (Avg)
Impedance	50 Ω
Efficiency	> 50 %
VSWR	< 2
Cable insertion Loss <1GHz	<1dB
Cable insertion Loss 1GHz~2.2GHz	<1.5dB
Cable insertion Loss 2.3GHz~2.7GHz	<2dB

NOTE

It is recommended to use a passive GNSS antenna when LTE B13 or B14 is supported, as the use of active antenna may generate harmonics which will affect the GNSS performance.

4.2.2 Recommended RF Connector for Antenna Installation

When choosing antennas, user should pay attentions to the connector on antenna which should match with the connector on the module.

The standard 2x2 mm size RF receptacle connectors have been used on SIM7906G-M2. The dimension of the connector on SIM7906G-M2 is 2.0*2.0*0.6mm, which is from I-PEX, and the Part Number is 20449-001E-03.

Shows the RF connector dimension in the following figure:

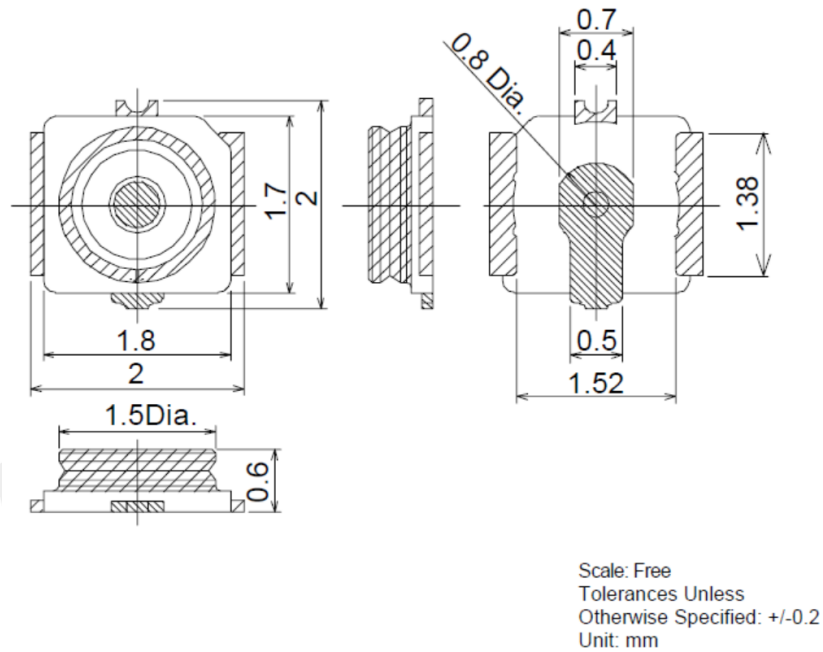

Figure 32: RF connector

The major specifications of the RF connector as below:

Table 34: the major specifications of the RF connector

Item	Specification
Nominal Frequency Range	DC to 6 GHz
Nominal Impedance	50Ω
Temperature Rating	-40°C to + 85°C
Initial Contact Resistance (without conductor resistance)	Center contact 20.0mΩmax. Outer contact 20.0mΩmax.
Voltage Standing Wave Ratio (V.S.W.R.)	Meet the requirements of 1.3max.(DC~3GHz) 1.45max.(3GHz~6GHz)

There are two kinds of coaxial cables mating the RF connector in the SIM7906G-M2, SIMCom recommend use Murata and SUZHOU KELI, and the Part Number is MXFR32HP1000 of the Murata and KLC-2058 of the KELI.

SIMCom
Confidential

5 Electrical Specifications

5.1 Absolute maximum ratings

Absolute maximum rating for digital and analog pins of module are listed in the following table:

Table 35: Absolute maximum ratings

Parameter	Min.	Typ.	Max.	Unit
Voltage at VBAT pins	-0.3	-	4.7	V
Voltage at digital pins (GPIO,I2C,UART, I2S)	-0.3	-	2.1	V
Voltage at digital pins (USIM)	-0.3	-	3.05	V
Voltage at FULCARD_POWER_OFF#	-0.3	-	4.7	V
Voltage at RESET#	-0.3	-	VBAT	V

5.2 Operating conditions

Table 36: Recommended operating ratings

Parameter	Min.	Typ.	Max.	Unit
Voltage at VBAT	3.135	3.3	4.4	V

Table 37: 1.8V Digital I/O characteristics*

Parameter	Description	Min.	Typ.	Max.	Unit
V _{IH}	High-level input voltage	1.17	1.8	2.1	V
V _{IL}	Low-level input voltage	-0.3	0	0.63	V
V _{OH}	High-level output voltage	1.35	-	1.8	V
V _{OL}	Low-level output voltage	0	-	0.45	V

I_{OH}	High-level output current(no pull down resistor)	-	2	-	mA
I_{OL}	Low-level output current(no pull up resistor)	-	-2	-	mA
I_{IH}	Input high leakage current (no pull down resistor)	-	-	1	uA
I_{IL}	Input low leakage current(no pull up resistor)	-1	-	-	uA

NOTE

These parameters are for digital interface pins, such as UART, I2C, ANTCTL and GPIOs (DPR, SIM DETECT).

The operating temperature of module is listed in the following table.

Table 38: Operating temperature

Parameter	Min.	Typ.	Max.	Unit
Normal operation temperature(3GPP compliant)	-30	25	70	°C
Extended operation temperature*	-40	25	85	°C
Storage temperature	-40	25	90	°C

NOTE

Module is able to make and receive voice calls, data calls, SMS and make UMTX/LTE traffic in $-40^{\circ}\text{C} \sim +85^{\circ}\text{C}$. The performance will be reduced slightly from the 3GPP specifications if the temperature is outside the normal operating temperature range and still within the extreme operating temperature range.

5.3 Operating Mode

5.3.1 Operating Mode Definition

The table below summarizes the various operating modes of module product.

Table 39: Operating mode Definition

Mode		Function
Normal operation	UMTS/LTE Sleep	AT command "AT+CSCLK=1" can be used to set the module to a sleep mode. In this case, the current consumption of module will be reduced to a very low level and the module can still receive paging message and SMS.
	UMTS/LTE Idle	Software is active. Module is registered to the network, and the module is ready to communicate.
	UMTS/LTE Talk	Connection between two subscribers is in progress. In this case, the power consumption depends on network settings such as DTX off/on, FR/EFR/HR, hopping sequences, and antenna.
	UMTS/LTE Standby	Module is ready for data transmission, but no data is currently sent or received. In this case, power consumption depends on network settings.
	UMTS/LTE Data transmission	There is data transmission in progress. In this case, power consumption is related to network settings (e.g. power control level); uplink/downlink data rates, etc.
Minimum functionality mode		AT command "AT+CFUN=0" can be used to set the module to a minimum functionality mode without removing the power supply. In this mode, the RF part of the module will not work and the USIM card will not be accessible, but the serial port and USB port are still accessible. The power consumption in this mode is lower than normal mode.
Flight mode		AT command "AT+CFUN=4" or pulling down the W_disable1# pin can be used to set the module to flight mode without removing the power supply. In this mode, the RF part of the module will not work, but the serial port and USB port are still accessible. The power consumption in this mode is lower than normal mode.
Power off		Module will go into power off mode by pull down the Full_Card_Power_Off# pin, normally. In this mode the power management unit shuts down the power supply, and software is not active. The serial port and USB are is not accessible.

5.3.2 Sleep mode

In sleep mode, the current consumption of module will be reduced to a very low level, and module can still receive paging message and SMS.

Several hardware and software conditions must be satisfied in order to let module enter into sleep mode:

1. UART condition
2. USB condition
3. Software condition

NOTE

Before designing, pay attention to how to realize sleeping/waking function.

5.3.3 Minimum functionality mode and Flight mode

Minimum functionality mode ceases a majority function of module, thus minimizing the power consumption. This mode is set by the AT command which provides a choice of the functionality levels.

AT+CFUN=0: Minimum functionality

AT+CFUN=1: Full functionality (Default)

AT+CFUN=4: Flight mode

If module has been set to minimum functionality mode, the RF function and USIM card function will be closed. In this case, the serial port and USB are still accessible, but RF function and USIM card will be unavailable.

If module has been set to flight mode, the RF function will be closed. In this case, the serial port and USB are still accessible, but RF function will be unavailable.

When module is in minimum functionality or flight mode, it can return to full functionality by the AT command "AT+CFUN=1".

5.4 RF Output Power/Current Consumption

The current consumption is listed in the table below.

Table 40: SIM7906G-M2 Current consumption on VBAT Pins (VBAT=3.3V)

UMTS sleep/idle mode			
WCDMA supply current (GNSS off, without USB connection)	Sleep mode @DRX=9	Typical:TBD mA	
	Idle mode @DRX=9	Typical: TBD mA	
LTE sleep/idle mode			
LTE FDD supply current (GNSS off, without USB connection)	Sleep mode	Typical:TBD mA	
	Idle mode	Typical: TBD mA	
LTE TDD supply current (GNSS off, without USB connection)	Sleep mode	Typical: TBD mA	
	Idle mode	Typical: TBD mA	
HSDPA data			
WCDMA B1	@Power	23.54 dBm	Typical: 683 mA
WCDMA B2	@Power	23.49dBm	Typical: 616 mA
WCDMA B3	@Power	23.25 dBm	Typical: 693 mA
WCDMA B4	@Power	24.2 dBm	Typical: 595 mA
WCDMA B5	@Power	23.45 dBm	Typical: 637 mA
WCDMA B6	@Power	23.48 dBm	Typical: 642 mA
WCDMA B8	@Power	23.86 dBm	Typical: 659 mA
WCDMA B9	@Power	23.37 dBm	Typical: 733 mA
WCDMA B19	@Power	23.53 dBm	Typical: 636 mA
LTE data			
LTE-FDD B1	@5MHz	22.87 dBm	Typical: 700 mA
	@10MHz	22.85 dBm	Typical: 715 mA
	@20MHz	22.96 dBm	Typical: 729 mA
LTE-FDD B2	@1.4MHz	23.04 dBm	Typical: TBD mA
	@5MHz	23.07 dBm	Typical: 627 mA
	@10MHz	23.03 dBm	Typical:643 mA
	@20MHz	23.06 dBm	Typical: 685 mA
LTE-FDD B3	@1.4MHz	22.98 dBm	Typical: 691 mA
	@5MHz	23.04 dBm	Typical: 710 mA
	@10MHz	23.03 dBm	Typical: 723 mA
	@20MHz	23.06 dBm	Typical: 754 mA
LTE-FDD B4	@1.4MHz	22.97 dBm	Typical: 658 mA
	@5MHz	23.18 dBm	Typical: 662 mA
	@10MHz	23.03 dBm	Typical: 665 mA
	@20MHz	23.09dBm	Typical: 676 mA
LTE-FDD B5	@1.4MHz	23.84 dBm	Typical: 703 mA
	@5MHz	23.88 dBm	Typical: 720 mA
	@10MHz	23.87 dBm	Typical: 752 mA

LTE-FDD B7	@5MHz	22.43 dBm	Typical: 642 mA
	@10MHz	22.59 dBm	Typical: 662 mA
	@20MHz	22.67 dBm	Typical: 731 mA
LTE-FDD B8	@1.4MHz	24.04 dBm	Typical: 715 mA
	@5MHz	24.07 dBm	Typical: 761 mA
	@10MHz	24.16 dBm	Typical: 808 mA
LTE-FDD B12	@1.4MHz	23.89 dBm	Typical: 746 mA
	@5MHz	24.03 dBm	Typical: 701 mA
	@10MHz	23.97 dBm	Typical: 655 mA
LTE-FDD B13	@5MHz	24.09 dBm	Typical: 827 mA
	@10MHz	24.06 dBm	Typical: 772 mA
LTE-FDD B14	@5MHz	24.01 dBm	Typical: 795 mA
	@10MHz	23.97 dBm	Typical: 803 mA
LTE-FDD B17	@5MHz	23.99 dBm	Typical: 766 mA
	@10MHz	24.02 dBm	Typical: 730 mA
LTE-FDD B18	@5MHz	24.07 dBm	Typical: 729 mA
	@10MHz	24.03 dBm	Typical: 740 mA
	@15MHz	24.06 dBm	Typical: 777 mA
LTE-FDD B19	@5MHz	24.13 dBm	Typical: 706 mA
	@10MHz	24.06 dBm	Typical: 736 mA
	@15MHz	24.01 dBm	Typical: 793 mA
LTE-FDD B20	@5MHz	23.98 dBm	Typical: 730 mA
	@10MHz	23.98 dBm	Typical: 688 mA
	@20MHz	23.97 dBm	Typical: 671 mA
LTE-FDD B25	@1.4MHz	23.01 dBm	Typical: 637 mA
	@5MHz	22.91 dBm	Typical: 632 mA
	@10MHz	23.03 dBm	Typical: 636 mA
	@20MHz	22.93dBm	Typical: 684 mA
LTE-FDD B26	@1.4MHz	24.15 dBm	Typical: 762 mA
	@5MHz	24.18 dBm	Typical:787 mA
	@10MHz	24.10 dBm	Typical: 794 mA
	@15MHz	24.07 dBm	Typical: 790 mA
LTE-FDD B28	@3MHz	24.05 dBm	Typical: 756 mA
	@5MHz	23.98 dBm	Typical: 752 mA
	@10MHz	24.01 dBm	Typical: 790 mA
	@20MHz	23.92 dBm	Typical: 886 mA
LTE-FDD B30	@5MHz	22.56 dBm	Typical: 778 mA
	@10MHz	22.45 dBm	Typical: 810 mA
LTE-FDD B66	@1.4MHz	22.96 dBm	Typical: 585 mA
	@5MHz	22.98 dBm	Typical: 586 mA
	@10MHz	23.03 dBm	Typical: 608 mA
	@20MHz	23.1 dBm	Typical: 647 mA
LTE-TDD B38	@5MHz	23.16 dBm	Typical :355 mA
	@10MHz	23.11 dBm	Typical :362 mA
	@20MHz	23.14 dBm	Typical :387 mA
LTE-TDD B40	@5MHz	23.09 dBm	Typical : 300 mA
	@10MHz	23.14 dBm	Typical : 312 mA
	@20MHz	23.10 dBm	Typical : 344 mA
LTE-TDD B41	@5MHz	22.97 dBm	Typical : 383 mA
	@10MHz	23.02 dBm	Typical : 414 mA
	@20MHz	23.08 dBm	Typical : 416 mA
LTE-TDD B42	@5MHz	22.49 dBm	Typical : 363 mA
	@10MHz	22.41 dBm	Typical : 365 mA
	@20MHz	22.37 dBm	Typical : 382 mA
LTE-TDD B43	@5MHz	21.85 dBm	Typical :392 mA
	@10MHz	21.81 dBm	Typical : 395 mA
	@20MHz	21.92 dBm	Typical : 413 mA
LTE-TDD B48	@5MHz	23.23 dBm	Typical : 395 mA

@10MHz	23.26 dBm	Typical : 398 mA
@20MHz	23.13 dBm	Typical : 410 mA

5.5 Conducted Receive Sensitivity

The following tables show conducted RF receiving sensitivity of SIM7906G-M2 module.

Table 41: SIM7906G-M2 Conducted RF Receiving Sensitivity

Frequency	SIM7906G-M2	
	3GPP Requirement (dBm)	Rx Sensitivity Typical(dBm)
WCDMA B1	-106.7	-112.1
WCDMA B2	-104.7	-113.5
WCDMA B3	-103.7	-112.5
WCDMA B4	-106.7	-111.7
WCDMA B5	-104.7	-113.5
WCDMA B6	-106.7	-113.5
WCDMA B8	-103.7	-113.6
WCDMA B9	-105.7	-113
WCDMA B19	-106.7	-113.5
LTE-FDD B1(10M)	-96.3	-99.2
LTE-FDD B2(10M)	-94.3	-100.5
LTE-FDD B3(10M)	-93.3	-100.3
LTE-FDD B4(10M)	-96.3	-99.3
LTE-FDD B5(10M)	-94.3	-101.2
LTE-FDD B7(10M)	-94.3	-100.6
LTE-FDD B8(10M)	-93.3	-100.8
LTE-FDD B12(10M)	-93.3	-100.7
LTE-FDD B13(10M)	-93.3	-100.3
LTE-FDD B14(10M)	-93.3	-96.5
LTE-FDD B17(10M)	-93.3	-100.6
LTE-FDD B18(10M)	-96.3	-101.2
LTE-FDD B19(10M)	-96.3	-101.1
LTE-FDD B20(10M)	-93.3	-100.8

LTE-FDD B25(10M)	-92.8	-100.3
LTE-FDD B26(10M)	-93.8	-101.3
LTE-FDD B28(10M)	-94.8	-100.7
LTE-FDD B30(10M)	-93.3	-99.8
LTE-FDD B66(10M)	-95.8	-99.8
LTE-TDD B38(10M)	-96.3	-101.5
LTE-TDD B40(10M)	-96.3	-101.3
LTE-TDD B41(10M)	-94.3	-101.1
LTE-TDD B42(10M)	-95	-101.8
LTE-TDD B43(10M)	-95	-101.4
LTE-TDD B48(10M)	-95	-101.5

NOTE

The data in above table are gotten at static condition.

SIMO is a smart antenna technology that uses a single antenna at the transmitter side and multiple (two for SIM7906G-M2) antennas at the receiver side, which can improve Rx performance.

Per 3GPP specification.

5.6 ESD

Module is sensitive to ESD in the process of storage, transporting, and assembling. When module is mounted on the users' mother board, the ESD components should be placed beside the connectors which human body may touch, such as USIM card holder, SD card holder, audio jacks, switches, USB interface, etc. The following table shows the module ESD measurement performance without any external ESD component.

Table 42: The ESD performance measurement table (Temperature: 25°C, Humidity: 45%)

Part	Contact discharge	Air discharge
VBAT,GND	+/-5K	+/-10K
Antenna port	+/-5K	+/-10K
Full_Card_Power_Off#	+/-2K	+/-4K
USB	+/-1K	+/-2K
RESET_N	+/-1K	+/-2K
USIM Card	+/-1K	+/-2K
Other PADS	+/-1K	+/-2K

6 Connect SIM7906G-M2 to board

The module should be equipped well by the connector and screw as the following figure illustration. The module Stand-off and mounting screw also serve as part of the module Electrical Ground path. The Stand-off should be connected directly to the ground plane on the platform. So that when the module is mounted and the mounting screw is screwed on to hold the module in place, this will make the electrical ground connection from the module to the platform ground plane.

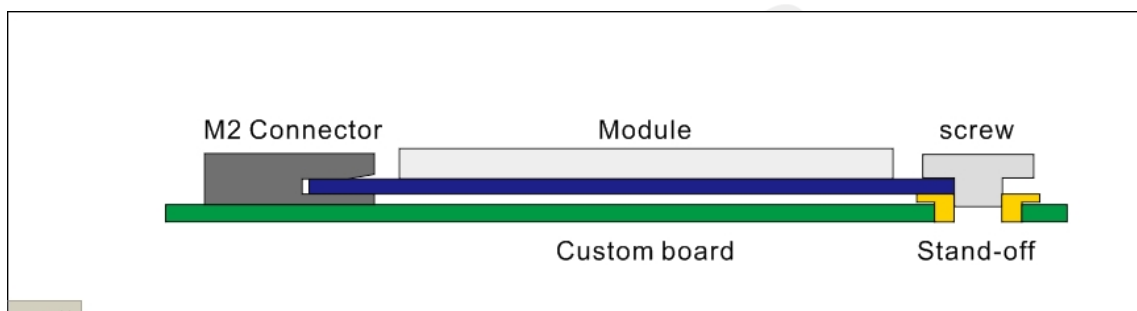

Figure 33: Equipment diagram

7 Thermal Design

Customer should pay attentions to the thermal design of SIM7906G-M2, for the mass data application scenario, the module would work in max power status and last long time, the temperature of module would increase quickly, especially in high temperature environment.

Module reserved a ground plane on the bottom side for the heat dissipating, customer could conduct the heat to the large board by the silica gel, and the surface area on large board should be more than 460 mm². For better thermal performance, customer could use a heat sink device to conduct the heat to the air.

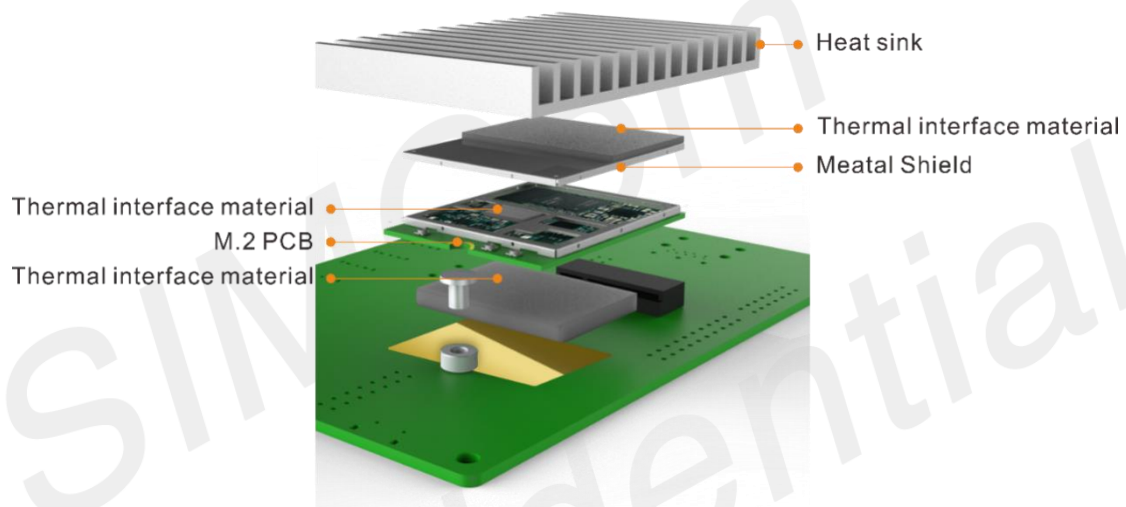

Figure 34: Thermal design diagram

Table 43: The silica gel selection guide

Item	Test method	Recommend value	Unit
Specific Gravity	ASTMD792	3.2±0.1	g/cc
Continuous use Temp	EN344	-40~+220	°C
Volume Resistivity	ASTMD257	1.0*10 ¹¹	Ω -CM
Voltage Endurance	ASTMD149	4	KV/mm
Flame Rating	UL-94	V-0	
Conductivity	ASTMD5470	8	w/m-k

8 Packaging

Module support tray packaging.

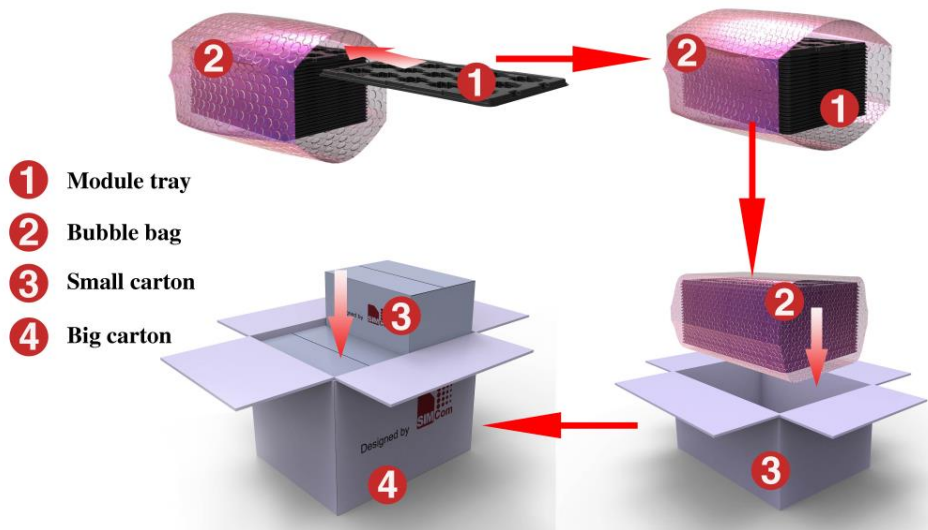

Figure 35: packaging diagram

Module tray drawing:

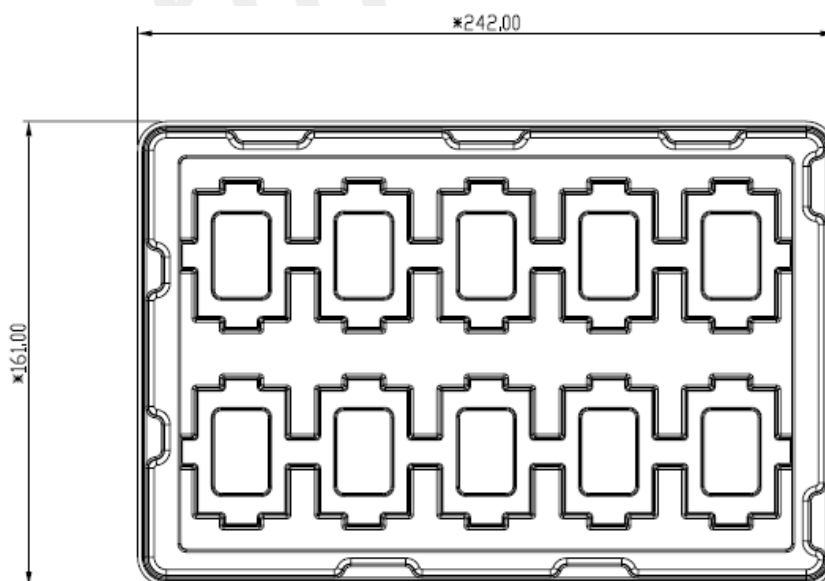

Figure 36: Tray drawing

Table 44: Tray size

Length ($\pm 3\text{mm}$)	Width ($\pm 3\text{mm}$)	Number
245.0	165.0	10

Small carton drawing:

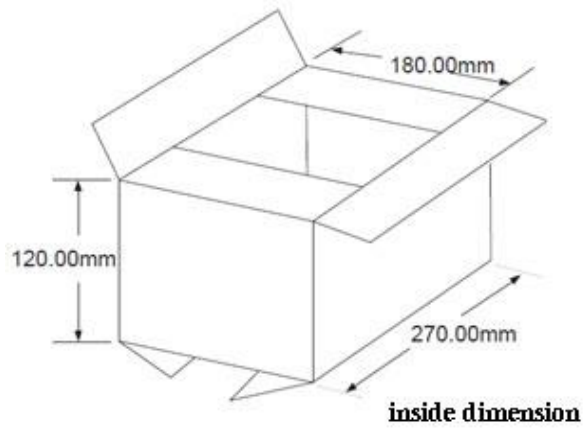

Figure 37: Small carton drawing

Table 45: Small Carton size

Length ($\pm 10\text{mm}$)	Width ($\pm 10\text{mm}$)	Height ($\pm 10\text{mm}$)	Number
270	180	120	10*20=200

Big carton drawing:

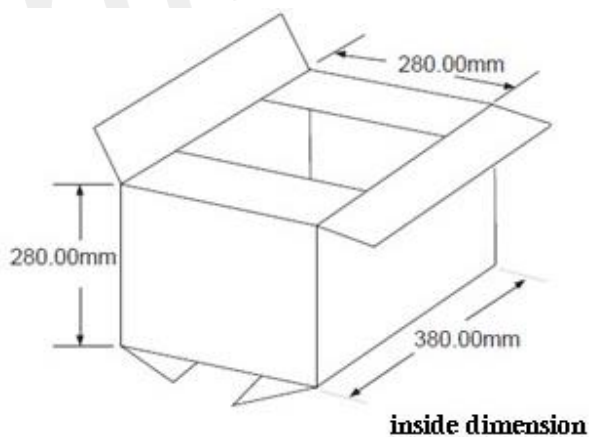

Figure 38: Big carton drawing

Table 46: Big Carton size

Length ($\pm 10\text{mm}$)	Width ($\pm 10\text{mm}$)	Height ($\pm 10\text{mm}$)	Number
380	280	280	200*4=800

SIMCom
Confidential

9 Appendix

9.1 Coding Schemes and Maximum Net Data Rates over Air Interface

Table 47: Coding Schemes and Maximum Net Data Rates over Air Interface

HSDPA device category	Max data rate (peak)	Modulation type
Category 1	1.2Mbps	16QAM,QPSK
Category 2	1.2Mbps	16QAM,QPSK
Category 3	1.8Mbps	16QAM,QPSK
Category 4	1.8Mbps	16QAM,QPSK
Category 5	3.6Mbps	16QAM,QPSK
Category 6	3.6Mbps	16QAM,QPSK
Category 7	7.2Mbps	16QAM,QPSK
Category 8	7.2Mbps	16QAM,QPSK
Category 9	10.2Mbps	16QAM,QPSK
Category 10	14.4Mbps	16QAM,QPSK
Category 11	0.9Mbps	QPSK
Category 12	1.8Mbps	QPSK
Category 13	17.6Mbps	64QAM
Category 14	21.1Mbps	64QAM
Category 15	23.4Mbps	16QAM
Category 16	28Mbps	16QAM
Category 17	23.4Mbps	64QAM
Category 18	28Mbps	64QAM
Category 19	35.5Mbps	64QAM
Category 20	42Mbps	64QAM
Category 21	23.4Mbps	16QAM
Category 22	28Mbps	16QAM
Category 23	35.5Mbps	64QAM
Category 24	42.2Mbps	64QAM
HSUPA device category	Max data rate (peak)	Modulation type
Category 1	0.96Mbps	QPSK
Category 2	1.92Mbps	QPSK

Category 3	1.92Mbps	QPSK
Category 4	3.84Mbps	QPSK
Category 5	3.84Mbps	QPSK
Category 6	5.76Mbps	QPSK
LTE-FDD device category (Downlink)	Max data rate (peak)	Modulation type
Category 1	10Mbps	QPSK/16QAM/64QAM
Category 2	50Mbps	QPSK/16QAM/64QAM
Category 3	100Mbps	QPSK/16QAM/64QAM
Category 4	150Mbps	QPSK/16QAM/64QAM
Category 5	300Mbps	QPSK/16QAM/64QAM
Category 6	300Mbps	QPSK/16QAM/64QAM
Category 12	600Mbps	QPSK/16QAM/64QAM/256QAM
LTE-FDD device category (Uplink)	Max data rate (peak)	Modulation type
Category 1	5Mbps	QPSK/16QAM
Category 2	25Mbps	QPSK/16QAM
Category 3	50Mbps	QPSK/16QAM
Category 4	50Mbps	QPSK/16QAM
Category 5	75Mbps	QPSK/16QAM/64QAM
Category 6	50Mbps	QPSK/16QAM
Category 12	100 Mbps	QPSK/16QAM/64QAM

9.2 Related Documents

Table 48: Related Documents

NO.	Title	Description
[1]	SIM7906G-M2 Series_AT Command Manual_V1.xx	AT Command Manual
[2]	ITU-T Draft recommendation V.25ter ^{new}	Serial asynchronous automatic dialing and control
[3]	GSM 07.07	Digital cellular telecommunications (Phase 2+); AT command set for GSM Mobile Equipment (ME)
[4]	GSM 07.10	Support GSM 07.10 multiplexing protocol
[5]	GSM 07.05	Digital cellular telecommunications (Phase 2+); Use of Data Terminal Equipment – Data Circuit terminating Equipment (DTE – DCE) interface for Short Message Service (SMS) and Cell Broadcast Service (CBS)
[6]	GSM 11.14	Digital cellular telecommunications system (Phase 2+); Specification of the SIM Application Toolkit for the Subscriber Identity Module – Mobile Equipment (SIM – ME) interface

[7]	GSM 11.11	Digital cellular telecommunications system (Phase 2+); Specification of the Subscriber Identity Module – Mobile Equipment (SIM – ME) interface
[8]	GSM 03.38	Digital cellular telecommunications system (Phase 2+); Alphabets and language-specific information
[9]	GSM 11.10	Digital cellular telecommunications system (Phase 2) ; Mobile Station (MS) conformance specification ; Part 1: Conformance specification
[10]	3GPP TS 51.010-1	Digital cellular telecommunications system (Release 5); Mobile Station (MS) conformance specification
[11]	3GPP TS 34.124	Electromagnetic Compatibility (EMC) for mobile terminals and ancillary equipment.
[12]	3GPP TS 34.121	Electromagnetic Compatibility (EMC) for mobile terminals and ancillary equipment.
[13]	3GPP TS 34.123-1	Technical Specification Group Radio Access Network; Terminal conformance specification; Radio transmission and reception (FDD)
[14]	3GPP TS 34.123-3	User Equipment (UE) conformance specification; Part 3: Abstract Test Suites.
[15]	EN 301 908-02 V2.2.1	Electromagnetic compatibility and Radio spectrum Matters (ERM); Base Stations (BS) and User Equipment (UE) for IMT-2000. Third Generation cellular networks; Part 2: Harmonized EN for IMT-2000, CDMA Direct Spread (UTRA FDD) (UE) covering essential requirements of article 3.2 of the R&TTE Directive
[16]	EN 301 489-24 V1.2.1	Electromagnetic compatibility and Radio Spectrum Matters (ERM); Electromagnetic Compatibility (EMC) standard for radio equipment and services; Part 24: Specific conditions for IMT-2000 CDMA Direct Spread (UTRA) for Mobile and portable (UE) radio and ancillary equipment
[17]	IEC/EN60950-1(2001)	Safety of information technology equipment (2000)
[18]	3GPP TS 51.010-1	Digital cellular telecommunications system (Release 5); Mobile Station (MS) conformance specification
[19]	GCF-CC V3.23.1	Global Certification Forum - Certification Criteria
[20]	2002/95/EC	Directive of the European Parliament and of the Council of 27 January 2003 on the restriction of the use of certain hazardous substances in electrical and electronic equipment (RoHS)
[21]	SIM7X00 Series_UART_Application Note_V1.xx	This document describes how to use UART interface of SIMCom modules.
[22]	SIM7X00 Series_GPS_Application Note_V1.xx	GPS Application Note
[23]	Antenna design guidelines for diversity receiver system	Antenna design guidelines for diversity receiver system

9.3 Terms and Abbreviations







Table 49: Terms and Abbreviations

Abbreviation	Description
ADC	Analog-to-Digital Converter
ARP	Antenna Reference Point
BER	Bit Error Rate
BTS	Base Transceiver Station
CS	Coding Scheme
CSD	Circuit Switched Data
CTS	Clear to Send
DAC	Digital-to-Analog Converter
DRX	Discontinuous Reception
DSP	Digital Signal Processor
DTE	Data Terminal Equipment (typically computer, terminal, printer)
DTR	Data Terminal Ready
DTX	Discontinuous Transmission
EFR	Enhanced Full Rate
EGSM	Enhanced GSM
EMC	Electromagnetic Compatibility
ESD	Electrostatic Discharge
ETS	European Telecommunication Standard
EVDO	Evolution Data Only
FCC	Federal Communications Commission (U.S.)
FD	SIM fix dialing phonebook
FDMA	Frequency Division Multiple Access
FR	Full Rate
GMSK	Gaussian Minimum Shift Keying
GNSS	Global Navigation Satellite System
GPRS	General Packet Radio Service
GPS	Global Positioning System
GSM	Global Standard for Mobile Communications
HR	Half Rate
HSPA	High Speed Packet Access
HSIC	High-speed Inter-chip
I2C	Inter-Integrated Circuit

IMEI	International Mobile Equipment Identity
LTE	Long Term Evolution
MDIO	Management Data Input/Output
MMD	MDIO manageable device
MO	Mobile Originated
MS	Mobile Station (GSM engine), also referred to as TE
MT	Mobile Terminated
NMEA	National Marine Electronics Association
PAP	Password Authentication Protocol
PBCCH	Packet Switched Broadcast Control Channel
PCB	Printed Circuit Board
PCS	Personal Communication System, also referred to as GSM 1900
RF	Radio Frequency
RMS	Root Mean Square (value)
RTC	Real Time Clock
SIM	Subscriber Identification Module
SMS	Short Message Service
SPI	serial peripheral interface
SMPS	Switched-mode power supply
TDMA	Time Division Multiple Access
TE	Terminal Equipment, also referred to as DTE
TX	Transmit Direction
UART	Universal Asynchronous Receiver & Transmitter
VSWR	Voltage Standing Wave Ratio
SM	SIM phonebook
SGMII	Serial gigabit media independent interface
NC	Not connect
EDGE	Enhanced data rates for GSM evolution
HSDPA	High Speed Downlink Packet Access
HSUPA	High Speed Uplink Packet Access
ZIF	Zero intermediate frequency
WCDMA	Wideband Code Division Multiple Access
VCTCXO	Voltage control temperature-compensated crystal oscillator
USIM	Universal subscriber identity module
UMTS	Universal mobile telecommunications system
UART	Universal asynchronous receiver transmitter

9.4 Safety Caution

Table 50: Safety Caution

Marks	Requirements
	<p>When in a hospital or other health care facility, observe the restrictions about the use of mobiles. Switch the cellular terminal or mobile off, medical equipment may be sensitive and not operate normally due to RF energy interference.</p>
	<p>Switch off the cellular terminal or mobile before boarding an aircraft. Make sure it is switched off. The operation of wireless appliances in an aircraft is forbidden to prevent interference with communication systems. Forgetting to think much of these instructions may impact the flight safety, or offend local legal action, or both.</p>
	<p>Do not operate the cellular terminal or mobile in the presence of flammable gases or fumes. Switch off the cellular terminal when you are near petrol stations, fuel depots, chemical plants or where blasting operations are in progress. Operation of any electrical equipment in potentially explosive atmospheres can constitute a safety hazard.</p>
	<p>Your cellular terminal or mobile receives and transmits radio frequency energy while switched on. RF interference can occur if it is used close to TV sets, radios, computers or other electric equipment.</p>
	<p>Road safety comes first! Do not use a hand-held cellular terminal or mobile when driving a vehicle, unless it is securely mounted in a holder for hands free operation. Before making a call with a hand-held terminal or mobile, park the vehicle.</p>
	<p>GSM cellular terminals or mobiles operate over radio frequency signals and cellular networks and cannot be guaranteed to connect in all conditions, especially with a mobile fee or an invalid SIM card. While you are in this condition and need emergent help, please remember to use emergency calls. In order to make or receive calls, the cellular terminal or mobile must be switched on and in a service area with adequate cellular signal strength.</p> <p>Some networks do not allow for emergency call if certain network services or phone features are in use (e.g. lock functions, fixed dialing etc.). You may have to deactivate those features before you can make an emergency call.</p> <p>Also, some networks require that a valid SIM card be properly inserted in the cellular terminal or mobile.</p>

Declaration of conformity

Herby, SIMCom Wireless Solutions Limited declares that this MODULE, SIM7906G-M2 is in compliance with the essential requirements and other relevant provisions of Directive 2014/53/EU.



Use the MODULE in the environment with the temperature between -30°C and 70°C.
The device complies with RF specifications when the device used at 5mm from your body.

FCC MODULAR APPROVAL INFORMATION EXAMPLES for Manual

This device complies with Part 15 of the FCC Rules. Operation is subject to the following two conditions:

- (1) This device may not cause harmful interference.
- (2) This device must accept any interference received, including interference that may cause undesired operation.

CAUTION: Changes or modifications not expressly approved by the party responsible for compliance could void the user's authority to operate the equipment.

NOTE: This equipment has been tested and found to comply with the limits for a Class B digital device, pursuant to Part 15 of the FCC Rules. These limits are designed to provide reasonable protection against harmful interference in a residential installation. This equipment generates uses and can radiate radio frequency energy and, if not installed and used in accordance with the instructions, may cause harmful interference to radio communications. However, there is no guarantee that interference will not occur in a particular installation. If this equipment does cause harmful interference to radio or television reception, which can be determined by turning the equipment off and on, the user is encouraged to try to correct the interference by one or more of the following measures:

- Reorient or relocate the receiving antenna.
- Increase the separation between the equipment and receiver.
- Connect the equipment into an outlet on a circuit different from that to which the receiver is connected.
- Consult the dealer or an experienced radio/TV technician for help.

FCC Radiation Exposure Statement:

This equipment complies with FCC radiation exposure limits set forth for an uncontrolled environment. This equipment should be installed and operated with minimum distance 20cm between the radiator & your body.

OEM INTEGRATION INSTRUCTIONS:

This device is intended only for OEM integrators under the following conditions:

The module must be installed in the host equipment such that 20 cm is maintained between the antenna and users, and the transmitter module may not be co-located with any other transmitter or antenna. The module shall be only used with the internal on-board antenna that has been originally tested and certified with this module. External antennas are not supported. As long as these 3 conditions above are met, further transmitter test will not be required.

However, the OEM integrator is still responsible for testing their end-product for any additional compliance requirements required with this module installed (for example, digital device emissions, PC peripheral requirements, etc.). The end-product may need Verification testing, Declaration of Conformity testing, a Permissive Class II Change or new Certification. Please involve a FCC certification specialist in order to determine what will be exactly applicable for the end-product.

Validity of using the module certification:

In the event that these conditions cannot be met (for example certain laptop configurations or co-location with another transmitter), then the FCC authorization for this module in combination with the host equipment is no longer considered valid and the FCC ID of the module cannot be used on the final product. In these circumstances, the OEM integrator will be responsible for re-evaluating the end product (including the transmitter) and obtaining a separate FCC authorization. In such cases, please involve a FCC certification specialist in order to determine if a Permissive Class II Change or new Certification is required.

Upgrade Firmware:

The software provided for firmware upgrade will not be capable to affect any RF parameters as certified for the FCC for this module, in order to prevent compliance issues.

End product labeling:

This transmitter module is authorized only for use in device where the antenna may be installed such that 20 cm may be maintained between the antenna and users. The final end product must be labeled in a visible area with the following: "Contains FCC ID: 2AJYU-8XM0003".

Information that must be placed in the end user manual:

The OEM integrator has to be aware not to provide information to the end user regarding how to install or remove this RF module in the user's manual of the end product which integrates this module. The end user manual shall include all required regulatory information/warning as show in this manual.

"CAUTION: Exposure to Radio Frequency Radiation.

Antenna shall be mounted in such a manner to minimize the potential for human contact during normal operation. The antenna should not be contacted during operation to avoid the possibility of exceeding the FCC radio frequency exposure limit.

Requirement per KDB996369 D03

2.2 List of applicable FCC rules

List the FCC rules that are applicable to the modular transmitter. These are the rules that specifically establish the bands of operation, the power, spurious emissions, and operating fundamental frequencies. DO NOT list compliance to unintentional-radiator rules (Part 15 Subpart B) since that is not a condition of a module grant that is extended to a host manufacturer. See also Section 2.10 below concerning the need to notify host manufacturers that further testing is required.³

Explanation: This module meets the requirements of FCC part 22, part 24, part 27, part90.

2.3 Summarize the specific operational use conditions

Describe use conditions that are applicable to the modular transmitter, including for example any limits on antennas, etc. For example, if point-to-point antennas are used that require reduction in power or compensation for cable loss, then this information must be in the instructions. If the use condition limitations extend to professional users, then instructions must state that this information also extends to the host manufacturer's instruction manual. In addition, certain information may also be needed, such as peak gain per frequency band and minimum gain, specifically for master devices in 5 GHz DFS bands.

Explanation: The EUT has a Rubber Duck Antenna, and the antenna use a permanently attached antenna which is not replaceable.

2.4 Limited module procedures

If a modular transmitter is approved as a "limited module," then the module manufacturer is responsible for approving the host environment that the limited module is used with. The manufacturer of a limited module must describe, both in the filing and in the installation instructions, the alternative means that the limited module manufacturer uses to verify that the host meets the necessary requirements to satisfy the module limiting conditions.

A limited module manufacturer has the flexibility to define its alternative method to address the conditions that limit the initial approval, such as: shielding, minimum signaling amplitude, buffered modulation/data inputs, or power supply regulation. The alternative method could include that the limited module manufacturer reviews detailed test data or host designs prior to giving the host manufacturer approval. This limited module procedure is also applicable for RF exposure evaluation when it is necessary to demonstrate compliance in a specific host. The module manufacturer must state how control of the product into which the modular transmitter will be installed will be maintained such that full compliance of the product is always ensured. For additional hosts other than the specific host originally granted with a limited module, a Class II permissive change is required on the module grant to register the additional host as a specific host also approved with the module.

Explanation: The module is not a limited module.

2.5 Trace antenna designs

For a modular transmitter with trace antenna designs, see the guidance in Question 11 of KDB Publication 996369 D02 FAQ – Modules for Micro-Strip Antennas and traces. The integration information shall include for the TCB review the integration instructions for the following aspects:

layout of trace design, parts list (BOM), antenna, connectors, and isolation requirements.

a) Information that includes permitted variances (e.g., trace boundary limits, thickness, length, width, shape(s),

dielectric constant, and impedance as applicable for each type of antenna);

b) Each design shall be considered a different type (e.g., antenna length in multiple(s) of frequency, the wavelength, and antenna shape (traces in phase) can affect antenna gain and must be considered);

c) The parameters shall be provided in a manner permitting host manufacturers to design the printed circuit (PC) board layout;

d) Appropriate parts by manufacturer and specifications;

e) Test procedures for design verification; and

f) Production test procedures for ensuring compliance.

The module grantee shall provide a notice that any deviation(s) from the defined parameters of the antenna trace, as described by the instructions, require that the host product manufacturer must notify the module grantee that they wish to change the antenna trace design. In this case, a Class II permissive change application is required to be filed by the grantee, or the host manufacturer can take responsibility through the change in FCC ID (new application) procedure followed by a Class II permissive change application.

Explanation: Yes, The module with trace antenna designs, and This manual has been shown the layout of trace design, antenna, connectors, and isolation requirements.

2.6 RF exposure considerations

It is essential for module grantees to clearly and explicitly state the RF exposure conditions that permit a host product manufacturer to use the module. Two types of instructions are required for RF exposure information: (1) to the host product manufacturer, to define the application conditions (mobile, portable – xx cm from a person's body); and (2) additional text needed for the host product manufacturer to provide to end users in their end-product manuals. If RF exposure statements and use conditions are not provided, then the host product manufacturer is required to take responsibility of the module through a change in FCC ID (new application).

Explanation: This module complies with FCC RF radiation exposure limits set forth for an uncontrolled environment, This equipment should be installed and operated with a minimum distance of 20 centimeters between the radiator and your body." This module is designed to comply with the FCC statement, FCC ID is: 2AJYU-8XM0004.

2.7 Antennas

A list of antennas included in the application for certification must be provided in the instructions. For modular transmitters approved as limited modules, all applicable professional installer instructions must be included as part of the information to the host product manufacturer. The antenna list shall also identify the antenna types (monopole, PIFA, dipole, etc. (note that for example an “omni-directional antenna” is not considered to be a specific “antenna type”)).

For situations where the host product manufacturer is responsible for an external connector, for example with an RF pin and antenna trace design, the integration instructions shall inform the installer that unique antenna connector must be used on the Part 15 authorized transmitters used in the host product. The module manufacturers shall provide a list of acceptable unique connectors.

Explanation: The EUT has a Rubber Duck Antenna, and the antenna use a permanently attached antenna which is not replaceable.

2.8 Label and compliance information

Grantees are responsible for the continued compliance of their modules to the FCC rules. This includes advising host product manufacturers that they need to provide a physical or e-label stating “Contains FCC ID” with their finished product. See Guidelines for Labeling and User Information for RF Devices – KDB Publication 784748.

Explanation: The host system using this module, should have label in a visible area indicated the following texts: “Contains FCC ID: 2AJYU-8XM0004”

2.9 Information on test modes and additional testing requirements

Additional guidance for testing host products is given in KDB Publication 996369 D04 Module Integration Guide. Test modes should take into consideration different operational conditions for a stand-alone modular transmitter in a host, as well as for multiple simultaneously transmitting modules or other transmitters in a host product.

The grantee should provide information on how to configure test modes for host product evaluation for different operational conditions for a stand-alone modular transmitter in a host, versus with multiple, simultaneously transmitting modules or other transmitters in a host.

Grantees can increase the utility of their modular transmitters by providing special means, modes, or instructions that simulates or characterizes a connection by enabling a transmitter. This can greatly simplify a host manufacturer’s determination that a module as installed in a host complies with FCC requirements.

Explanation: Top band can increase the utility of our modular transmitters by providing instructions that simulates or characterizes a connection by enabling a transmitter.

2.10 Additional testing, Part 15 Subpart B disclaimer

The grantee should include a statement that the modular transmitter is only FCC authorized for the specific rule parts (i.e., FCC transmitter rules) listed on the grant, and that the host product manufacturer is responsible for compliance to any other FCC rules that apply to the host not covered by the modular transmitter grant of certification. If the grantee markets their product as being Part 15 Subpart B compliant (when it also contains unintentional-radiator digital circuitry), then the grantee shall provide a notice stating that the final host product still requires Part 15 Subpart B compliance testing with the modular transmitter installed.

Explanation: The module without unintentional-radiator digital circuitry, so the module does not

require an evaluation by FCC Part 15 Subpart B. The host should be evaluated by the FCC Subpart B.

SIMCom
Confidential