

FCC TEST REPORT

For

LTE /HSPA/GSM/GNSS MODULE

Model Number: SIM7600G, SIM7600G miniPCIE

FCC ID: 2AJYU-8PYA004

Report Number : WT208000042

Test Laboratory : Shenzhen Academy of Metrology and Quality
Inspection
Site Location : NETC Building, No.4 Tongfa Rd., Xili, Nanshan,
Shenzhen, China
Tel : 0086-755-86928965
Fax : 0086-755-86009898-31396
Web : www.smq.com.cn
E-mail : emcrf@smq.com.cn

Test report declaration

Applicant : SIMCom Wireless Solutions Limited
Address : No.633 Jinzhong Road,Shanghai

Manufacturer : SIMCom Wireless Solutions Limited
Address : No.633 Jinzhong Road,Shanghai

EUT : LTE /HSPA/GSM/GNSS MODULE
Description
Model No : SIM7600G, SIM7600G miniPCIE
Trade mark : SIMCom
FCC ID : 2AJYU-8PYA004

Test Standards:

FCC PART 90S

The EUT described above is tested by Shenzhen Academy of Metrology and Quality Inspection EMC Laboratory to determine the maximum emissions from the EUT. Shenzhen Academy of Metrology and Quality Inspection EMC Laboratory is assumed full responsibility for the accuracy of the test results. The test data, data evaluation, test procedures, and equipment configurations shown in this report were made in accordance with the procedures given in ANSI C63.26 (2015) and the energy emitted by the sample EUT tested as described in this report is in compliance with FCC Rules Part 90S.

The test report is valid for above tested sample only and shall not be reproduced in part without written approval of the laboratory.

Project Engineer: 陈司林 Date: Mar.05, 2020
(Chen Silin 陈司林)

Checked by: 林奕翔 Date: Mar.05, 2020
(Lin Yixiang 林奕翔)

Approved by: 林斌 Date: Mar.05, 2020
(Lin Bin 林斌)

TABLE OF CONTENTS

TEST REPORT DECLARATION	2
1. TEST RESULTS SUMMARY	4
2. GENERAL INFORMATION	5
2.1. Report information	5
2.2. Laboratory Accreditation and Relationship to Customer	5
2.3. Measurement Uncertainty	6
3. PRODUCT DESCRIPTION	7
3.1. EUT Description	7
3.2. Related Submittal(s) / Grant (s)	7
3.3. Block Diagram of EUT Configuration	8
3.4. Operating Condition of EUT	8
3.5. Support Equipment List	13
3.6. Test Conditions	13
3.7. Special Accessories	13
3.8. Equipment Modifications	13
4. TEST EQUIPMENT USED	14
5. TEST RESULTS	15
5.1. RF Power Output	15
5.2. Peak to Average Ratio	20
5.3. Occupied Bandwidth/Emission Bandwidth	28
5.4. Spurious Emission at Antenna Terminal	37
5.5. Spurious Emissions Radiated	73
5.6. Frequency Stability	78

1. TEST RESULTS SUMMARY

Table 1 Test Results Summary

FCC Measurement Specification	FCC Limits Part(s)	Description	Result
2.1046	90.205 90.635	Effective Radiated Power of Transmitter	PASS
2.1046	N/A	Peak to Average Ratio	PASS
2.1049	90.209	Occupied Bandwidth	PASS
2.1051	90.691	Spurious Emission at Antenna Terminal	PASS
2.1053	90.691	Radiated Spurious Emissions	PASS
2.1055	90.213	Frequency Stability	PASS

Remark: "N/A" means "Not applicable."

The tests documented in this report were performed in accordance with ANSI C63.26 (2015), FCC CFR 47 Part 2, FCC CFR 47 Part 90S.

2. GENERAL INFORMATION

2.1. Report information

This report is not a certificate of quality; it only applies to the sample of the specific product/equipment given at the time of its testing. The results are not used to indicate or imply that they are application to the similar items. In addition, such results must not be used to indicate or imply that SMQ approves recommends or endorses the manufacture, supplier or use of such product/equipment, or that SMQ in any way guarantees the later performance of the product/equipment.

The samples mentioned in this report is/are supplied by Applicant, SMQ therefore assumes no responsibility for the accuracy of information on the brand name, model number, origin of manufacture or any information supplied.

Additional copies of the report are available to the Applicant at an additional fee. No third part can obtain a copy of this report through SMQ, unless the applicant has authorized SMQ in writing to do so.

2.2. Laboratory Accreditation and Relationship to Customer

The testing report were performed by the Shenzhen Academy of Metrology and The testing report were performed by the Shenzhen Academy of Metrology and quality Inspection EMC Laboratory (Guangdong EMC compliance testing center), in their facilities located at NETC Building, No.4 Tongfa Rd., Xili, Nanshan, Shenzhen, China. At the time of testing, Laboratory is accredited by the following organizations:

China National Accreditation Service for Conformity Assessment (CNAS) accredits the Laboratory for conformance to FCC standards, EMC international standards and EN standards. The Registration Number is CNAS L0579.

The Laboratory is Accredited Testing Laboratory of FCC with Designation number CN1165 and Site registration number 582918.

The Laboratory is registered to perform emission tests with Innovation, Science and Economic Development (ISED), and the registration number is 11177A.

2.3. Measurement Uncertainty

For a 95% confidence level ($k = 2$), the measurement expanded uncertainties for defined systems, in accordance with the recommendations of ISO 17025 as following:

Radiated Emission

30MHz~1000MHz 4.5dB

1GHz~26.5GHz 4.6dB

26dB & Occupied Bandwidth: $\pm 0.39\%$

Frequency Stability: $\pm 0.42\%$

Peak to Average Ratio: 0.45 dB

Conducted power: 0.3 dB

Temperature: ± 0.698

Supply voltages: $\pm 0.15\%$

3. PRODUCT DESCRIPTION

3.1. EUT Description

Table 2 Specification of the Equipment under Test

Product Type:	LTE /HSPA/GSM/GNSS MODULE
Hardware Revision :	V1.02
Software Revision :	SIM7600M21-A_V2.0
FCC ID:	2AJYU-8PYA004
Frequency:	LTE Band 26: TX 814 ~ 849 MHz RX 859 ~ 894MHz
Type(s) of Modulation:	LTE:QPSK, 16QAM
Antenna Type:	Internal antenna Typical gain: 814MHz~824MHz 8dBi
Operating voltage:	DC: 3.3V (Low)/3.8V (Nominal)/ 4.2V (Max)

Table 3 Identification of the Equipment Under Test (EUT)

EUT	Serial Number/IMEI	HW Version	SW Version	Notes
1	868822040005520	V1.02	SIM7600M21-A_V2.0	Conducted testing sample.
2	868822040005520	V1.02	SIM7600M21-A_V2.0	Radiated testing sample.

Table 4 Identification of Accessory equipment

AE #	Type	Manufacturer	Model	Serial Number
--	--	--	--	--

3.2. Related Submittal(s) / Grant (s)

This submittal(s) (test report) is intended for FCC ID: 2AJYU-8PYA004 filing to comply with FCC PART 90S.

3.3. Block Diagram of EUT Configuration

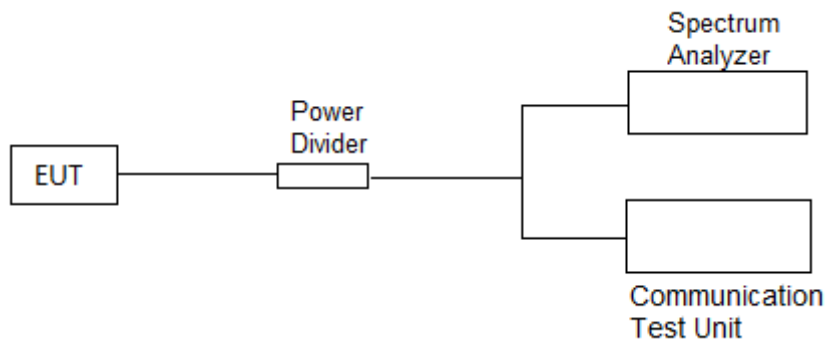

Figure 1 EUT setup of test mode 1&2

3.4. Operating Condition of EUT

During all testing, EUT is in link mode with base station emulator at maximum power level. The spurious emission measurements were carried out in semi-anechoic chamber with 3-meter test range, and EUT is rotated on three test planes to find out the worst emission (X plane).

TM1: LTE Mode with QPSK Modulation

TM2: LTE Mode with 16QAM Modulation

The maximum power levels are LTE Mode for QPSK link, LTE mode for 16QAM link, only these modes were used for all tests.

The conducted power tables are as follows:
 LTE Band 26(1.4MHz)

Channel Bandwidth: 1.4 MHz					
Modulation	Channel	Frequency (MHz)	RB Configuration		Average Power [dBm]
			Size	Offset	
QPSK	26697	814.7	1	0	23.01
			1	3	22.87
			1	5	22.79
			3	0	22.88
			3	2	22.79
			3	3	22.84
	26740	819	1	0	22.75
			1	3	22.88
			1	5	22.66
			3	0	22.72
			3	2	22.74
			3	3	22.96
	26783	823.3	6	0	21.81
			1	0	22.74
			1	3	23.02
			1	5	22.81
			3	0	22.74
			3	2	22.94
16QAM	26697	814.7	3	3	22.87
			6	0	21.76
			1	0	21.88
			1	3	22.03
			1	5	21.97
			3	0	21.97
	26740	819	3	2	21.92
			3	3	22.01
			6	0	20.72
			1	0	21.68
			1	3	21.77
			1	5	21.73
	26783	823.3	3	0	21.66
			3	2	21.57
			3	3	21.78
			6	0	20.96
			1	0	22.03
			1	3	22.38
26783	823.3	1	5	22.11	
		3	0	21.95	
		3	2	21.95	
		3	3	22.18	
		6	0	20.85	
		6	0	20.85	

LTE Band 26(3MHz)

Channel Bandwidth: 3 MHz					
Modulation	Channel	Frequency (MHz)	RB Configuration		Average Power [dBm]
			Size	Offset	
QPSK	26705	815.5	1	0	22.94
			1	7	22.82
			1	14	22.93
			8	0	21.71
			8	4	21.69
			8	7	21.77
	26740	819	15	0	21.69
			1	0	22.74
			1	7	22.62
			1	14	22.91
			8	0	21.78
			8	4	21.80
	26775	822.5	8	7	21.75
			15	0	21.77
			1	0	22.82
			1	7	23.17
			1	14	23.31
			8	0	21.86
16QAM	26705	815.5	8	4	21.96
			8	7	21.87
			15	0	21.87
			1	0	22.13
			1	7	22.26
			1	14	22.47
	26740	819	8	0	20.77
			8	4	20.80
			8	7	20.60
			15	0	20.84
			1	0	21.75
			1	7	21.69
	26775	822.5	1	14	22.30
			8	0	20.78
			8	4	20.81
			8	7	20.85
			15	0	20.81
			1	0	22.19
26775	822.5	1	7	22.13	
		1	14	22.46	
		8	0	20.95	
		8	4	20.96	
		8	7	21.02	
		15	0	20.99	

LTE Band 26(5MHz)

Channel Bandwidth: 5 MHz					
Modulation	Channel	Frequency (MHz)	RB Configuration		Average Power [dBm]
			Size	Offset	
QPSK	26715	816.5	1	0	22.79
			1	12	22.97
			1	24	22.74
			12	0	21.76
			12	6	21.67
			12	13	21.72
	26740	819	25	0	21.73
			1	0	22.56
			1	12	22.92
			1	24	22.51
			12	0	21.70
			12	6	21.72
	26765	821.5	12	13	21.74
			12	0	21.78
			25	0	21.87
			1	0	22.87
			1	12	23.14
			1	24	22.84
16QAM	26715	816.5	12	0	21.68
			12	6	21.82
			12	13	21.93
			25	0	21.84
			1	0	21.85
			1	12	21.95
	26740	819	1	24	22.00
			12	0	20.84
			12	6	20.88
			12	13	20.85
			25	0	20.87
			1	0	21.39
	26765	821.5	1	12	21.65
			1	24	21.46
			12	0	20.73
			12	6	20.74
			12	13	20.76
			25	0	20.95
26765	821.5	1	0	21.67	
		1	12	21.99	
		1	24	21.76	
		12	0	20.66	
		12	6	20.80	
		12	13	20.92	
25	0	20.98			

LTE Band 26(10MHz)

Channel Bandwidth: 10 MHz					
Modulation	Channel	Frequency (MHz)	RB Configuration		Average Power [dBm]
			Size	Offset	
QPSK	26740	819	1	0	22.68
			1	24	22.96
			1	49	23.19
			25	0	21.79
			25	12	21.76
			25	25	21.81
			50	0	21.67
16QAM	26740	819	1	0	22.10
			1	24	22.63
			1	49	22.45
			25	0	20.89
			25	12	20.85
			25	25	20.79
			50	0	20.97

3.5. Support Equipment List

Table 5 Support Equipment List

Name	Model No	S/N	Manufacturer
--	--	--	--

3.6. Test Conditions

Date of test : Feb.17, 2020 - Mar.05, 2020

Date of EUT Receive : Jan.07, 2020

Temperature: -30~50 °C

Relative Humidity: 39 - 51%

3.7. Special Accessories

Not available for this EUT intended for grant.

3.8. Equipment Modifications

Not available for this EUT intended for grant.

4. TEST EQUIPMENT USED

Table 6 Test Equipment

No.	Equipment	Manufacturer	Model No.	Last Cal.	Cal. Interval
SB8501/09	EMI Test Receiver	Rohde & Schwarz	ESU40	Mar.11, 2019	1 Year
SB5472/02	Bilog Antenna	Schwarzbeck	VULB9163	May.31, 2019	1 Year
SB3435	Horn Antenna	Rohde & Schwarz	HF906	Dec.17, 2019	1 Year
SB8501/14	Preamplifier	Rohde & Schwarz	SCU-03	Feb.17, 2020	1 Year
SB8501/17	Preamplifier	Rohde & Schwarz	SCU-18	Feb.17, 2020	1 Year
SB9054/02	Wideband Radio Communication Tester	Rohde & Schwarz	CMW500	Oct.21, 2019	1 Year
SB9721/02	Signal Analyzer	Agilent	N9020A	Nov.18, 2019	1 Year
SB11818	Temperature&Humidity Test chamber	EH-010U	Espec	Mar.25, 2019	1 Year
SB9721/07	DC Power Supply	Agilent	66319D	--	--
--	Power Divider	Tonscend	--	--	--
--	Test software	Tonscend	JS1120-1 LTE NEW	--	--
--	Test software	Rohde & Schwarz	EMC 32 8.50.0	--	--
--	Filter, HPF 1.2GHz	Mini-Circuits	VHF-1200+	--	--
--	Filter, HPF 3.0GHz	Wainwright Instruments GmbH	WHK3.0/18G-10 FE	--	--
--	Radiated Cable Set	Huber+Suhner	W22.01 AP5 X1	--	--
--	Radiated Cable Set	Huber+Suhner	W22.01 AP5 X1	--	--
--	Radiated Cable Set	Huber+Suhner	W11.20 CBL6112	--	--
--	Radiated Cable Set	Huber+Suhner	W11.20 CBL6112	--	--
--	Radiated Cable Set	Huber+Suhner	SUCOFLEX 100	--	--
--	Conducted Cable Set	Huber+Suhner	SUCOFLEX 104	--	--
--	Conducted Cable Set	Huber+Suhner	SUCOFLEX 104	--	--

5. TEST RESULTS

5.1. RF Power Output

5.1.1. Test Standard

FCC: CFR Part 2.1046, CFR Part 90.

5.1.2. Test Limit

FCC 90.635 (b) Power limits.

The maximum output power of the transmitter for mobile stations is 100 watts (20 dBW).

5.1.3. Test Procedure

ANSI C63.26:2015

KDB 971168 Section 5.6

$EIRP \text{ (dBm)} = ERP \text{ (dBm)} + 2.15 \text{ (dB)}$

$ERP/EIRP = P_{Meas} + GT - LC$

where: ERP/EIRP = effective or equivalent radiated power, respectively (expressed in the same

units as P_{Meas} , typically dBW or dBm);

P_{Meas} = measured transmitter output power or PSD, in dBm or dBW;

GT = gain of the transmitting antenna, in dBd (ERP) or dBi (EIRP);

LC = signal attenuation in the connecting cable between the transmitter and antenna, in dB.

For devices utilizing multiple antennas, KDB 662911 provides guidance for determining the effective array transmit antenna gain term to be used in the above equation.

EUT includes different power levels for head use configuration and body use configuration and the below tables contain the highest of all configurations average conducted and ERP/EIRP output powers as follows:

5.1.4. Test Data

LTE Band 26(1.4MHz)

Channel Bandwidth: 1.4 MHz									
Modulation	Channel	Frequency (MHz)	RB Configuration		Conducted Average Power [dBm]	Antenna Gain [dBi]	ERP Average [dBm]	ERP Limit [dBm]	Verdict
			Size	Offset					
QPSK	26697	814.7	1	0	23.01	8	28.86	50.00	Pass
			1	3	22.87	8	28.72	50.00	Pass
			1	5	22.79	8	28.64	50.00	Pass
			3	0	22.88	8	28.73	50.00	Pass
			3	2	22.79	8	28.64	50.00	Pass
			3	3	22.84	8	28.69	50.00	Pass
			6	0	21.70	8	27.55	50.00	Pass
	26740	819	1	0	22.75	8	28.6	50.00	Pass
			1	3	22.88	8	28.73	50.00	Pass
			1	5	22.66	8	28.51	50.00	Pass
			3	0	22.72	8	28.57	50.00	Pass
			3	2	22.74	8	28.59	50.00	Pass
			3	3	22.96	8	28.81	50.00	Pass
			6	0	21.81	8	27.66	50.00	Pass
	26783	823.3	1	0	22.74	8	28.59	50.00	Pass
			1	3	23.02	8	28.87	50.00	Pass
			1	5	22.81	8	28.66	50.00	Pass
			3	0	22.74	8	28.59	50.00	Pass
			3	2	22.94	8	28.79	50.00	Pass
			3	3	22.87	8	28.72	50.00	Pass
			6	0	21.76	8	27.61	50.00	Pass
16QAM	26697	814.7	1	0	21.88	8	27.73	50.00	Pass
			1	3	22.03	8	27.88	50.00	Pass
			1	5	21.97	8	27.82	50.00	Pass
			3	0	21.97	8	27.82	50.00	Pass
			3	2	21.92	8	27.77	50.00	Pass
			3	3	22.01	8	27.86	50.00	Pass
			6	0	20.72	8	26.57	50.00	Pass
	26740	819	1	0	21.68	8	27.53	50.00	Pass
			1	3	21.77	8	27.62	50.00	Pass
			1	5	21.73	8	27.58	50.00	Pass
			3	0	21.66	8	27.51	50.00	Pass
			3	2	21.57	8	27.42	50.00	Pass
			3	3	21.78	8	27.63	50.00	Pass
			6	0	20.96	8	26.81	50.00	Pass
	26783	823.3	1	0	22.03	8	27.88	50.00	Pass
			1	3	22.38	8	28.23	50.00	Pass
			1	5	22.11	8	27.96	50.00	Pass
			3	0	21.95	8	27.8	50.00	Pass
			3	2	21.95	8	27.8	50.00	Pass
			3	3	22.18	8	28.03	50.00	Pass
			6	0	20.85	8	26.7	50.00	Pass

LTE Band 26(3MHz)

Channel Bandwidth: 3 MHz									
Modulation	Channel	Frequency (MHz)	RB Configuration		Conducted Average Power [dBm]	Antenna Gain [dBi]	ERP Average [dBm]	ERP Limit [dBm]	Verdict
			Size	Offset					
QPSK	26705	815.5	1	0	22.94	8	28.79	50.00	Pass
			1	7	22.82	8	28.67	50.00	Pass
			1	14	22.93	8	28.78	50.00	Pass
			8	0	21.71	8	27.56	50.00	Pass
			8	4	21.69	8	27.54	50.00	Pass
			8	7	21.77	8	27.62	50.00	Pass
			15	0	21.69	8	27.54	50.00	Pass
	26740	819	1	0	22.74	8	28.59	50.00	Pass
			1	7	22.62	8	28.47	50.00	Pass
			1	14	22.91	8	28.76	50.00	Pass
			8	0	21.78	8	27.63	50.00	Pass
			8	4	21.80	8	27.65	50.00	Pass
			8	7	21.75	8	27.6	50.00	Pass
			15	0	21.77	8	27.62	50.00	Pass
	26775	822.5	1	0	22.82	8	28.67	50.00	Pass
			1	7	23.17	8	29.02	50.00	Pass
			1	14	23.31	8	29.16	50.00	Pass
			8	0	21.86	8	27.71	50.00	Pass
			8	4	21.96	8	27.81	50.00	Pass
			8	7	21.87	8	27.72	50.00	Pass
			15	0	21.87	8	27.72	50.00	Pass
16QAM	26705	815.5	1	0	22.13	8	27.98	50.00	Pass
			1	7	22.26	8	28.11	50.00	Pass
			1	14	22.47	8	28.32	50.00	Pass
			8	0	20.77	8	26.62	50.00	Pass
			8	4	20.80	8	26.65	50.00	Pass
			8	7	20.60	8	26.45	50.00	Pass
			15	0	20.84	8	26.69	50.00	Pass
	26740	819	1	0	21.75	8	27.6	50.00	Pass
			1	7	21.69	8	27.54	50.00	Pass
			1	14	22.30	8	28.15	50.00	Pass
			8	0	20.78	8	26.63	50.00	Pass
			8	4	20.81	8	26.66	50.00	Pass
			8	7	20.85	8	26.7	50.00	Pass
			15	0	20.81	8	26.66	50.00	Pass
	26775	822.5	1	0	22.19	8	28.04	50.00	Pass
			1	7	22.13	8	27.98	50.00	Pass
			1	14	22.46	8	28.31	50.00	Pass
			8	0	20.95	8	26.8	50.00	Pass
			8	4	20.96	8	26.81	50.00	Pass
			8	7	21.02	8	26.87	50.00	Pass
			15	0	20.99	8	26.84	50.00	Pass

LTE Band 26(5MHz)

Channel Bandwidth: 5 MHz									
Modulation	Channel	Frequency (MHz)	RB Configuration		Conducted Average Power [dBm]	Antenna Gain [dBi]	ERP Average [dBm]	ERP Limit [dBm]	Verdict
			Size	Offset					
QPSK	26715	816.5	1	0	22.79	8	28.64	50.00	Pass
			1	12	22.97	8	28.82	50.00	Pass
			1	24	22.74	8	28.59	50.00	Pass
			12	0	21.76	8	27.61	50.00	Pass
			12	6	21.67	8	27.52	50.00	Pass
			12	13	21.72	8	27.57	50.00	Pass
			25	0	21.73	8	27.58	50.00	Pass
	26740	819	1	0	22.56	8	28.41	50.00	Pass
			1	12	22.92	8	28.77	50.00	Pass
			1	24	22.51	8	28.36	50.00	Pass
			12	0	21.70	8	27.55	50.00	Pass
			12	6	21.72	8	27.57	50.00	Pass
			12	13	21.74	8	27.59	50.00	Pass
			25	0	21.78	8	27.63	50.00	Pass
	26765	821.5	1	0	22.87	8	28.72	50.00	Pass
			1	12	23.14	8	28.99	50.00	Pass
			1	24	22.84	8	28.69	50.00	Pass
			12	0	21.68	8	27.53	50.00	Pass
			12	6	21.82	8	27.67	50.00	Pass
			12	13	21.93	8	27.78	50.00	Pass
			25	0	21.84	8	27.69	50.00	Pass
16QAM	26715	816.5	1	0	21.85	8	27.7	50.00	Pass
			1	12	21.95	8	27.8	50.00	Pass
			1	24	22.00	8	27.85	50.00	Pass
			12	0	20.84	8	26.69	50.00	Pass
			12	6	20.88	8	26.73	50.00	Pass
			12	13	20.85	8	26.7	50.00	Pass
			25	0	20.87	8	26.72	50.00	Pass
	26740	819	1	0	21.39	8	27.24	50.00	Pass
			1	12	21.65	8	27.5	50.00	Pass
			1	24	21.46	8	27.31	50.00	Pass
			12	0	20.73	8	26.58	50.00	Pass
			12	6	20.74	8	26.59	50.00	Pass
			12	13	20.76	8	26.61	50.00	Pass
			25	0	20.95	8	26.8	50.00	Pass
	26765	821.5	1	0	21.67	8	27.52	50.00	Pass
			1	12	21.99	8	27.84	50.00	Pass
			1	24	21.76	8	27.61	50.00	Pass
			12	0	20.66	8	26.51	50.00	Pass
			12	6	20.80	8	26.65	50.00	Pass
			12	13	20.92	8	26.77	50.00	Pass
			25	0	20.98	8	26.83	50.00	Pass

LTE Band 26(10MHz)

Channel Bandwidth: 10 MHz									
Modulation	Channel	Frequency (MHz)	RB Configuration		Conducted Average Power [dBm]	Antenna Gain [dBi]	ERP Average [dBm]	ERP Limit [dBm]	Verdict
			Size	Offset					
QPSK	26740	819	1	0	22.68	-0.5	28.53	50.00	Pass
			1	24	22.96	-0.5	28.81	50.00	Pass
			1	49	23.19	-0.5	29.04	50.00	Pass
			25	0	21.79	-0.5	27.64	50.00	Pass
			25	12	21.76	-0.5	27.61	50.00	Pass
			25	25	21.81	-0.5	27.66	50.00	Pass
			50	0	21.67	-0.5	27.52	50.00	Pass
16QAM	26740	819	1	0	22.10	-0.5	27.95	50.00	Pass
			1	24	22.63	-0.5	28.48	50.00	Pass
			1	49	22.45	-0.5	28.3	50.00	Pass
			25	0	20.89	-0.5	26.74	50.00	Pass
			25	12	20.85	-0.5	26.7	50.00	Pass
			25	25	20.79	-0.5	26.64	50.00	Pass
			50	0	20.97	-0.5	26.82	50.00	Pass

5.2. Peak to Average Ratio

5.2.1. Test Standard

FCC: CFR 47 (FCC) part 2.1046

5.2.2. Test Limit

The peak-to-average ratio (PAR) of the transmission may not exceed 13 dB.

5.2.3. Test Procedure

For LTE operating mode:

- a. The EUT was connected to spectrum and system simulator via a power divider.
- b. Set the CCDF (Complementary Cumulative Distribution Function) option in spectrum analyzer.
- c. The highest RF powers were measured and recorded the maximum PAPR level associated with a probability of 0.1%.
- d. Record the deviation as Peak to Average Ratio.

5.2.4. Test Data

LTE Band 26:

Channel Bandwidth: 1.4MHz						
Modulation	Test Channel	RB Configuration		Peak-to-Average Ratio (dB)	Limit (dB)	Verdict
		Size	Offset			
QPSK	814.7	6	0	4.90	<13	PASS
	819.0	6	0	5.03	<13	PASS
	823.3	6	0	4.93	<13	PASS
16QAM	814.7	6	0	5.75	<13	PASS
	819.0	6	0	5.88	<13	PASS
	823.3	6	0	5.79	<13	PASS

Channel Bandwidth: 3MHz						
Modulation	Test Channel	RB Configuration		Peak-to-Average Ratio (dB)	Limit (dB)	Verdict
		Size	Offset			
QPSK	815.5	15	0	5.16	<13	PASS
	819.0	15	0	5.23	<13	PASS
	822.5	15	0	5.07	<13	PASS
16QAM	815.5	15	0	6.04	<13	PASS
	819.0	15	0	6.08	<13	PASS
	822.5	15	0	5.94	<13	PASS

Channel Bandwidth: 5MHz						
Modulation	Test Channel	RB Configuration		Peak-to-Average Ratio (dB)	Limit (dB)	Verdict
		Size	Offset			
QPSK	816.5	25	0	5.10	<13	PASS
	819	25	0	5.10	<13	PASS
	821.5	25	0	5.07	<13	PASS
16QAM	816.5	25	0	5.92	<13	PASS
	819	25	0	5.90	<13	PASS
	821.5	25	0	5.85	<13	PASS

Channel Bandwidth: 10MHz						
Modulation	Test Channel	RB Configuration		Peak-to-Average Ratio (dB)	Limit (dB)	Verdict
		Size	Offset			
QPSK	819.0	50	0	5.23	<13	PASS
16QAM	819.0	50	0	4.43	<13	PASS

Test Graphs

Band26_1.4MHz_QPSK_26697_6RB#0

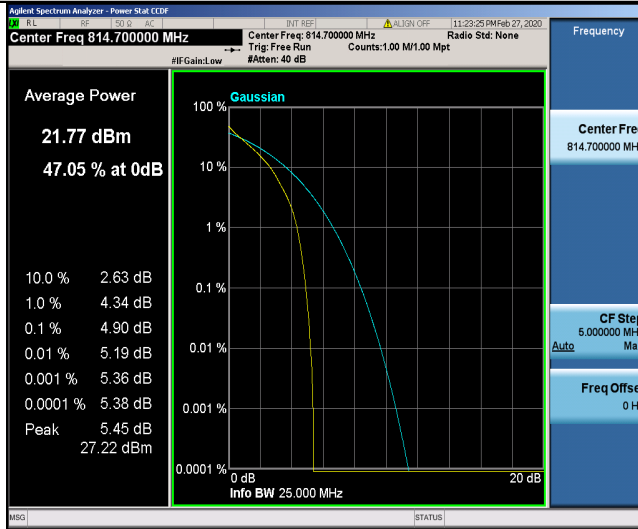

Band26_1.4MHz_QPSK_26740_6RB#0

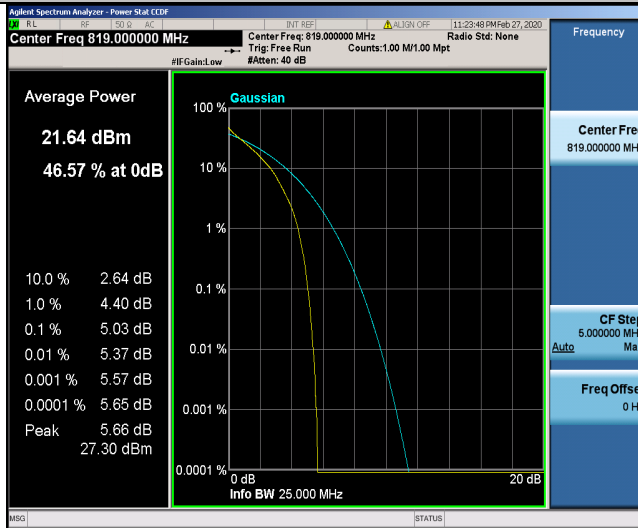

Band26_1.4MHz_QPSK_26783_6RB#0



Band26_1.4MHz_16QAM_26697_6RB#0

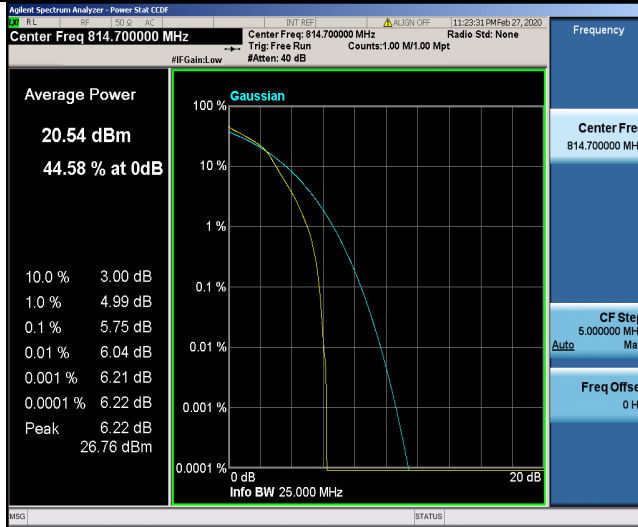

Band26_1.4MHz_16QAM_26740_6RB#0

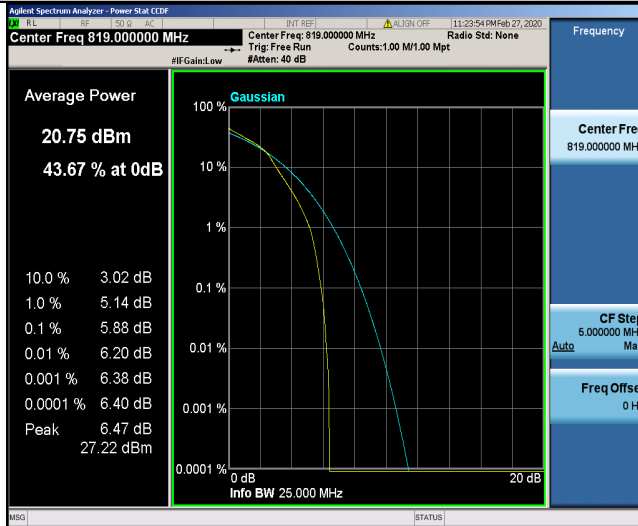

Band26_1.4MHz_16QAM_26783_6RB#0

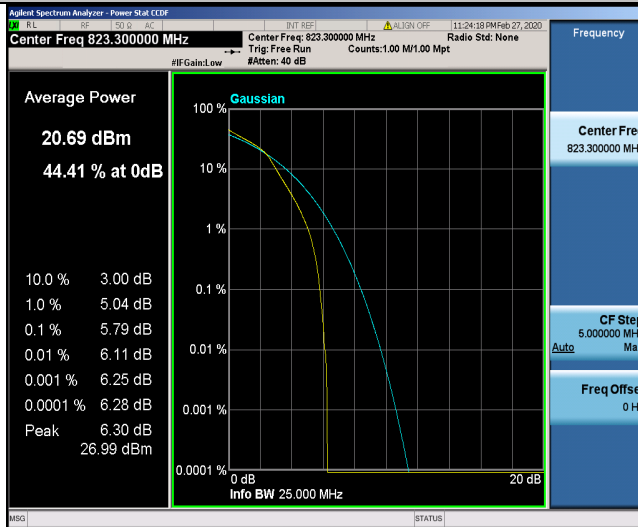

Band26_3MHz_QPSK_26705_15RB#0

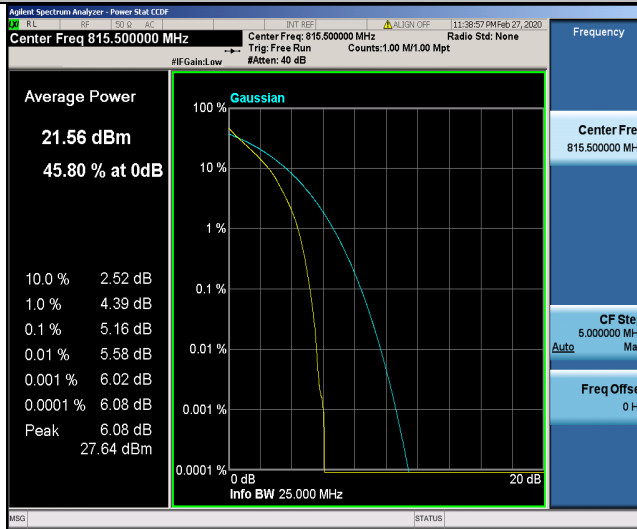

Band26_3MHz_QPSK_26740_15RB#0

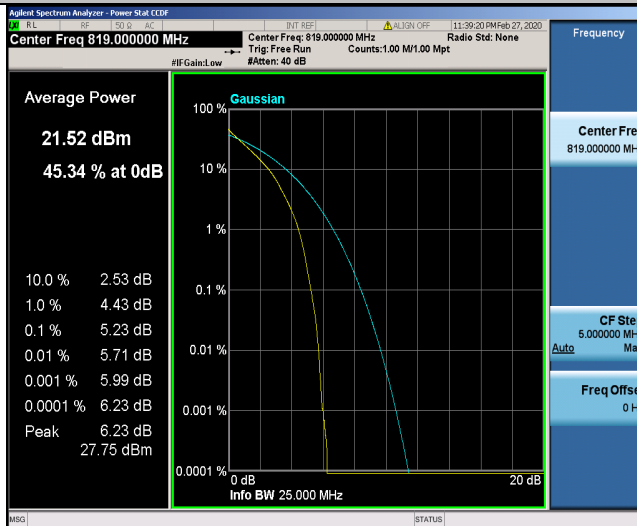

Band26_3MHz_QPSK_26775_15RB#0

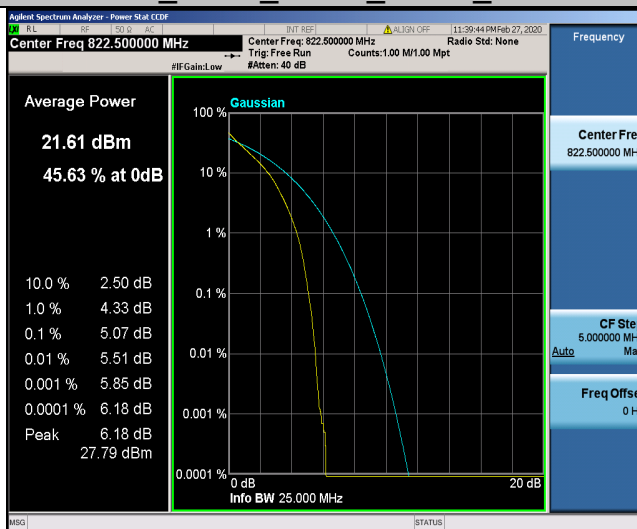

Band26_3MHz_16QAM_26705_15RB#0

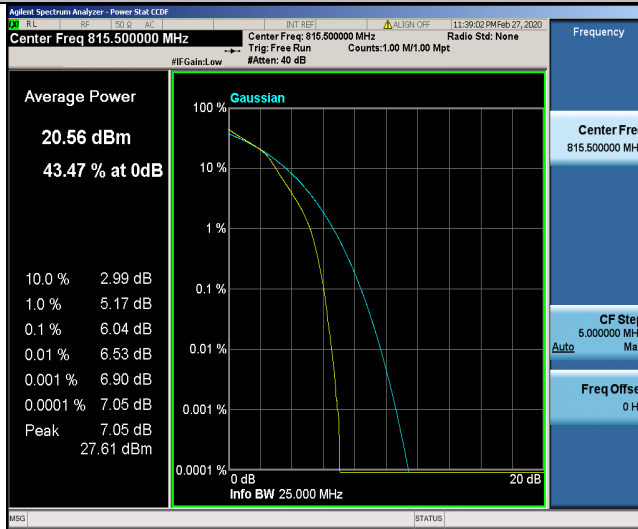

Band26_3MHz_16QAM_26740_15RB#0



Band26_3MHz_16QAM_26775_15RB#0

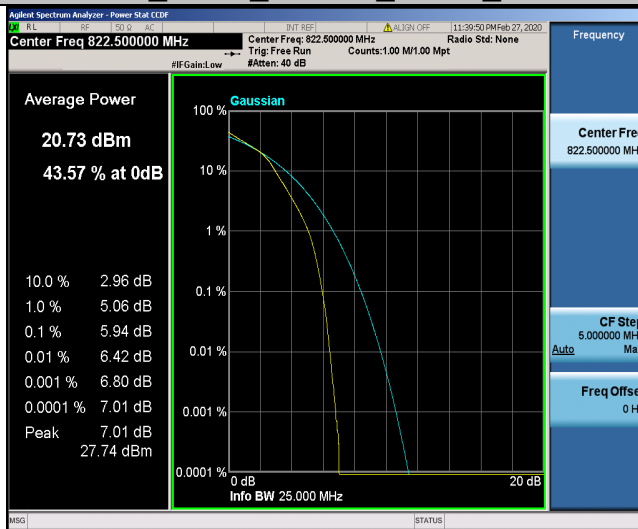

Band26_5MHz_QPSK_26715_25RB#0

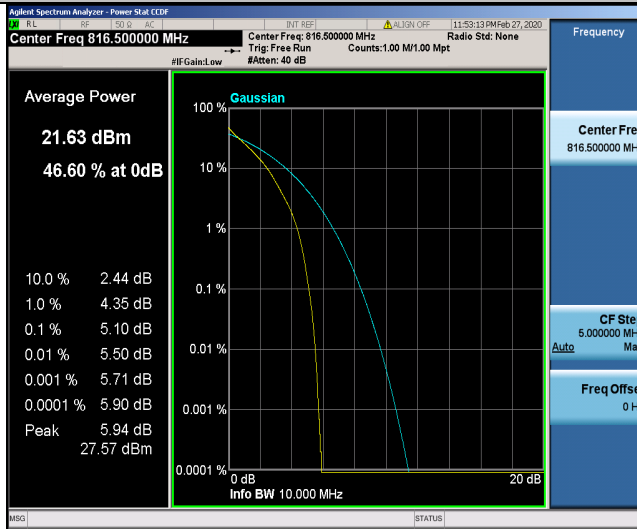

Band26_5MHz_QPSK_26740_25RB#0

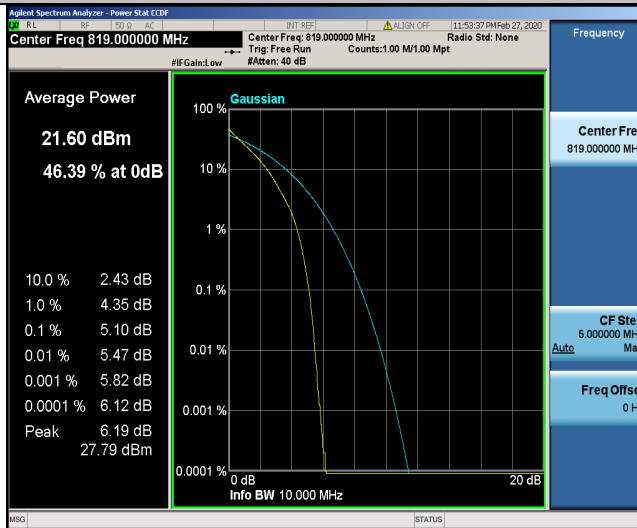

Band26_5MHz_QPSK_26765_25RB#0

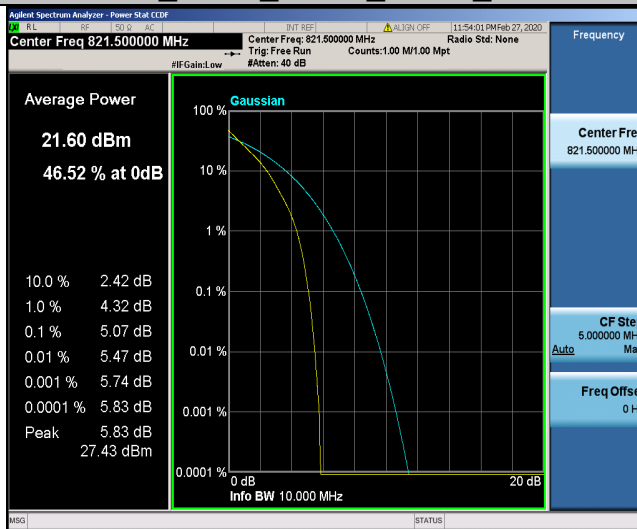

Band26_5MHz_16QAM_26715_25RB#0

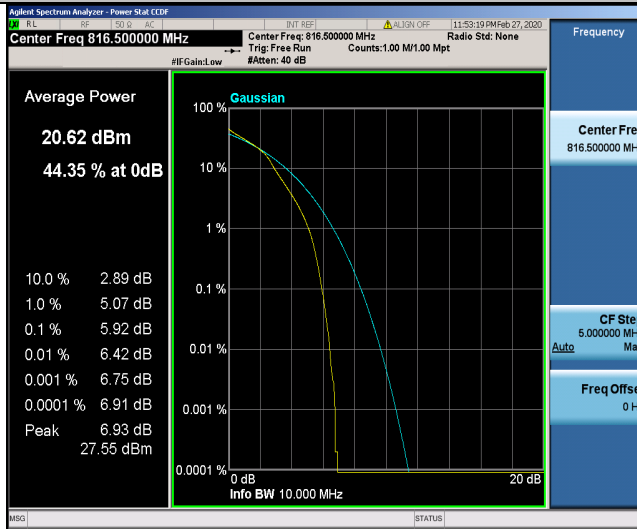

Band26_5MHz_16QAM_26740_25RB#0

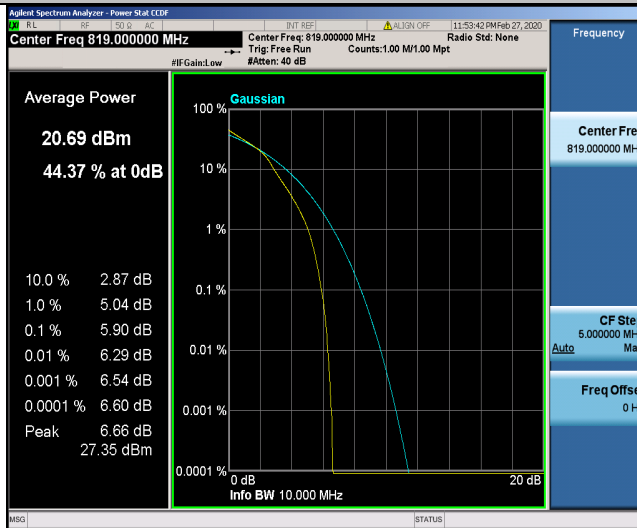

Band26_5MHz_16QAM_26765_25RB#0

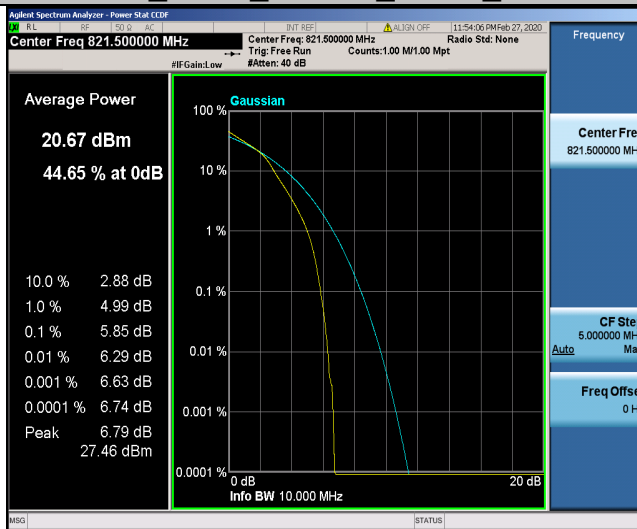

Band26_10MHz_QPSK_26740_50RB#0

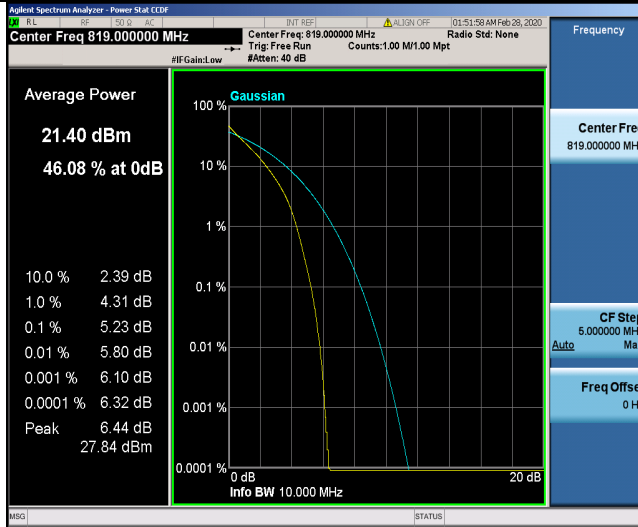

Band26_10MHz_16QAM_26740_50RB#0

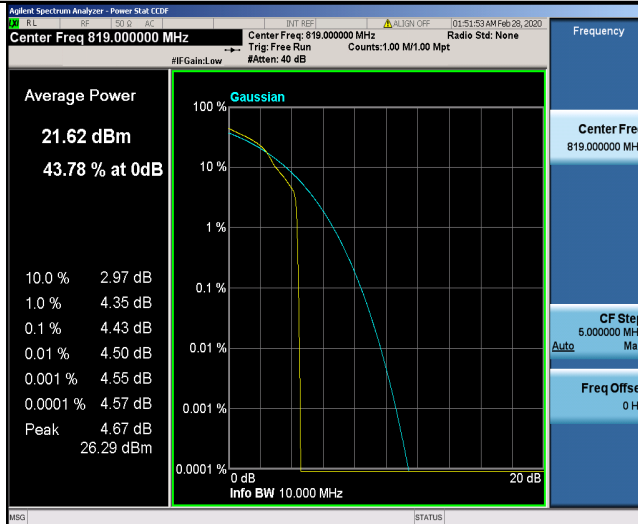

5.3. Occupied Bandwidth/Emission Bandwidth

5.3.1. Test Standard

FCC: CFR Part 2.1049, CFR Part 90.209

5.3.2. Test Limit

The occupied bandwidth, that is the frequency bandwidth such that, below its lower and above its upper frequency limits, the mean powers radiated are each equal to 0.5 percent of the total mean power radiated by a given emission shall be measured under the following conditions as applicable.

Transmitters employing digital modulation techniques-when modulated by an input signal such that its amplitude and symbol rate represent the maximum rated conditions under which the equipment will be operated.

5.3.3. Test Procedure

1. Connect the equipment as shown in the above diagram.
 2. Adjust the settings of the Wideband Radio Communication Tester (CMW500) to set the EUT to its maximum power at the required channel.
 3. Set the spectrum analyzer to measure the 99% occupied bandwidth. Record the value.
 4. Set the spectrum analyzer to measure the -26 dB emission bandwidth. Record the value.
 5. Measurements are to be performed with the EUT set to the low, middle and high channel of each frequency band.
- Spectrum analyzer settings: Measurement bandwidth of at least 1% of the occupied bandwidth.

5.3.4. Test Data

LTE Band 26:

Channel Bandwidth: 1.4 MHz						
Modulation	Channel	RB Configuration		Occupied Bandwidth (MHz)	26dB Bandwidth (MHz)	Verdict
		Size	Offset			
QPSK	LCH	6	0	1.1103	1.280	PASS
	MCH	6	0	1.1087	1.270	PASS
	HCH	6	0	1.1035	1.280	PASS
16QAM	LCH	6	0	1.1101	1.282	PASS
	MCH	6	0	1.1110	1.304	PASS
	HCH	6	0	1.1092	1.278	PASS

Channel Bandwidth: 3 MHz						
Modulation	Channel	RB Configuration		Occupied Bandwidth (MHz)	26dB Bandwidth (MHz)	Verdict
		Size	Offset			
QPSK	LCH	15	0	2.6784	2.876	PASS
	MCH	15	0	2.6882	2.889	PASS
	HCH	15	0	2.6872	2.888	PASS
16QAM	LCH	15	0	2.6846	2.885	PASS
	MCH	15	0	2.6847	2.890	PASS
	HCH	15	0	2.6894	2.882	PASS

Channel Bandwidth: 5 MHz						
Modulation	Channel	RB Configuration		Occupied Bandwidth (MHz)	26dB Bandwidth (MHz)	Verdict
		Size	Offset			
QPSK	LCH	25	0	4.4771	4.822	PASS
	MCH	25	0	4.4753	4.798	PASS
	HCH	25	0	4.4727	4.844	PASS
16QAM	LCH	25	0	4.4762	4.777	PASS
	MCH	25	0	4.4696	4.827	PASS
	HCH	25	0	4.4761	4.810	PASS

Channel Bandwidth: 10 MHz						
Modulation	Channel	RB Configuration		Occupied Bandwidth (MHz)	26dB Bandwidth (MHz)	Verdict
		Size	Offset			
QPSK	--	50	0	8.9307	9.468	PASS
16QAM	--	50	0	8.9351	9.425	PASS

Test Graphs

Band26 1.4MHz QPSK 26697 6RB#0

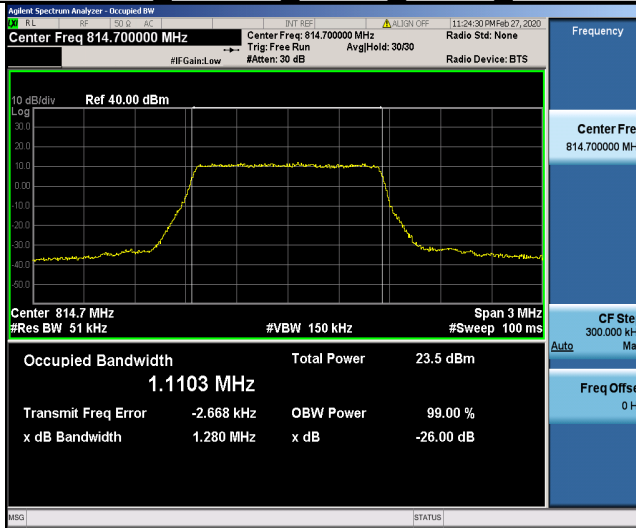

Band26 1.4MHz QPSK 26740 6RB#0

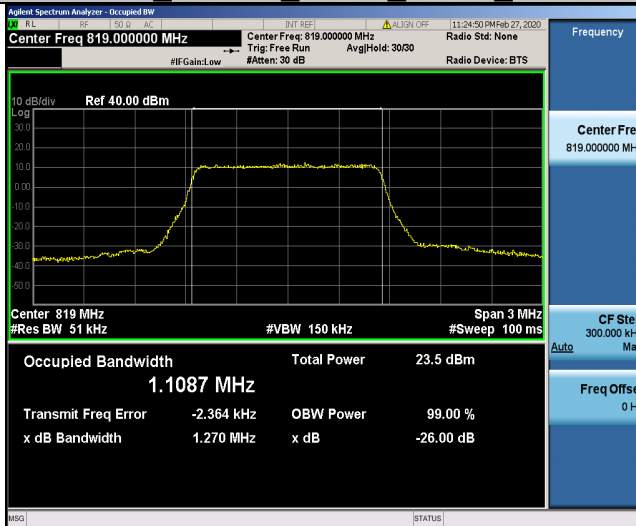

Band26 1.4MHz QPSK 26783 6RB#0

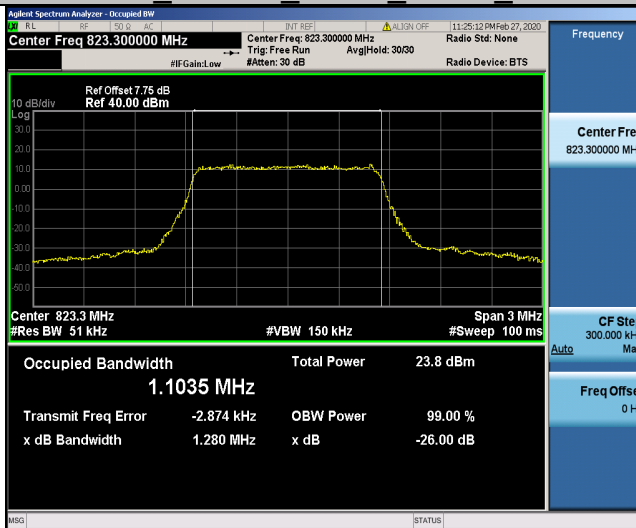

Band26 1.4MHz 16QAM 26697 6RB#0

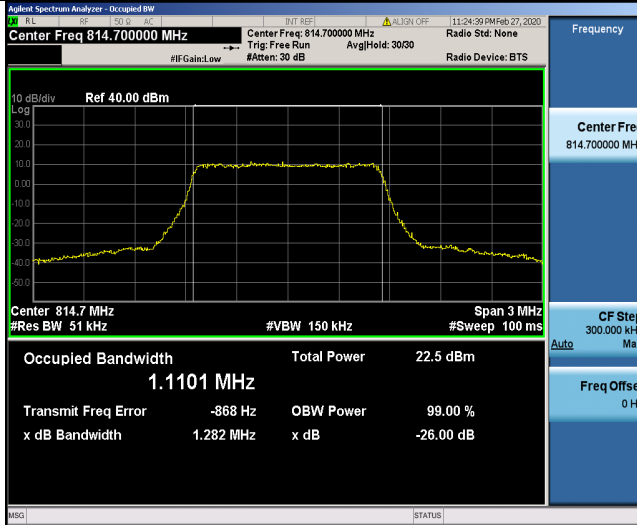

Band26 1.4MHz 16QAM 26740 6RB#0

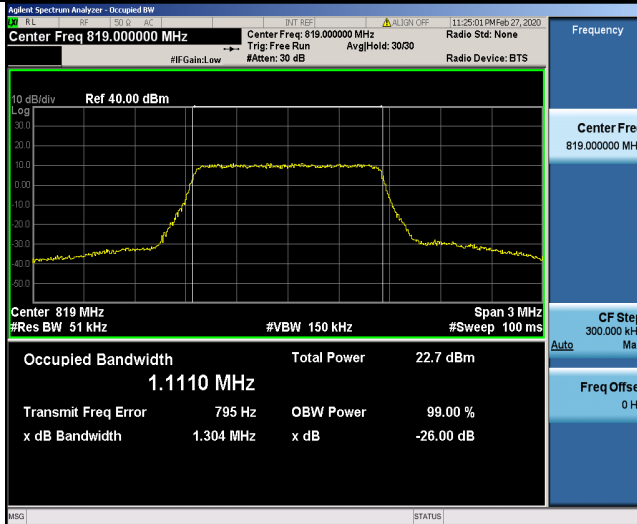

Band26 1.4MHz 16QAM 26783 6RB#0

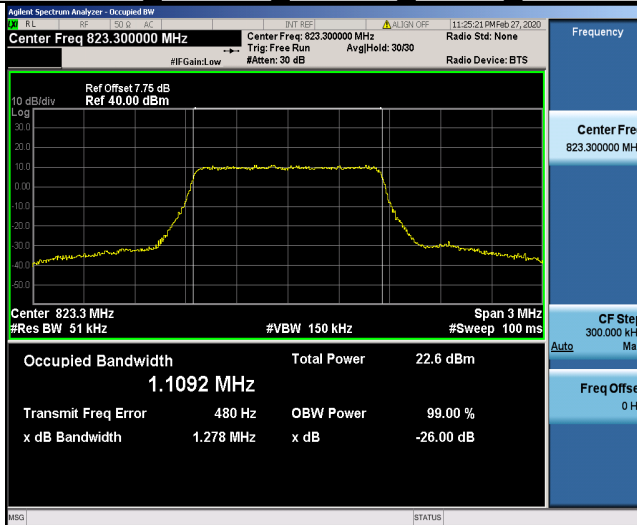

Band26 3MHz QPSK 26705 15RB#0

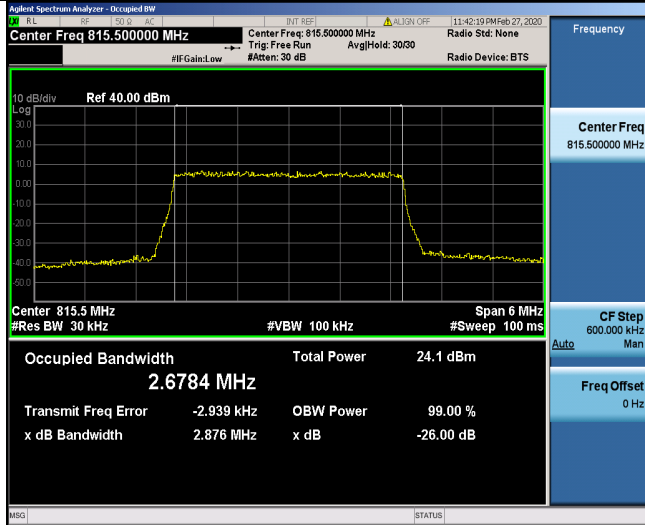

Band26 3MHz QPSK 26740 15RB#0

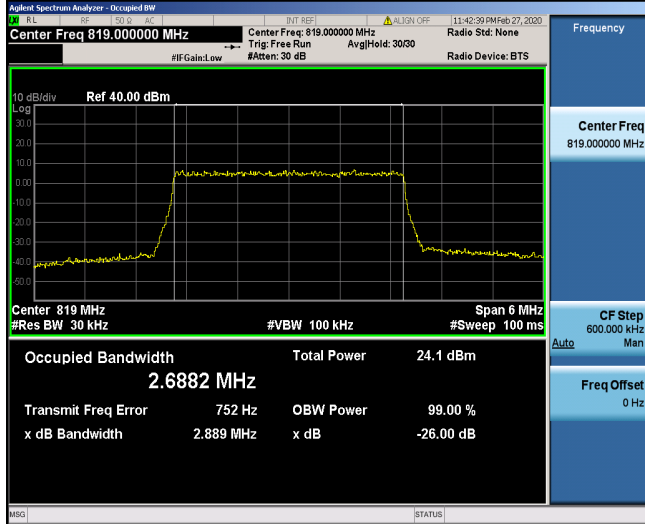

Band26 3MHz QPSK 26775 15RB#0

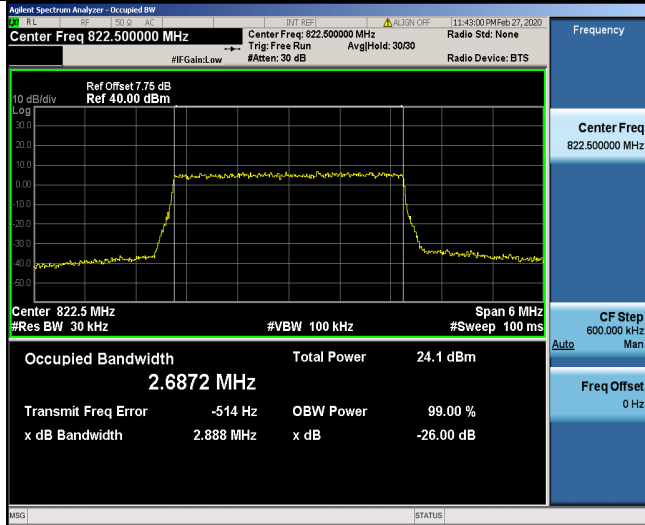

Band26 3MHz 16QAM 26705 15RB#0

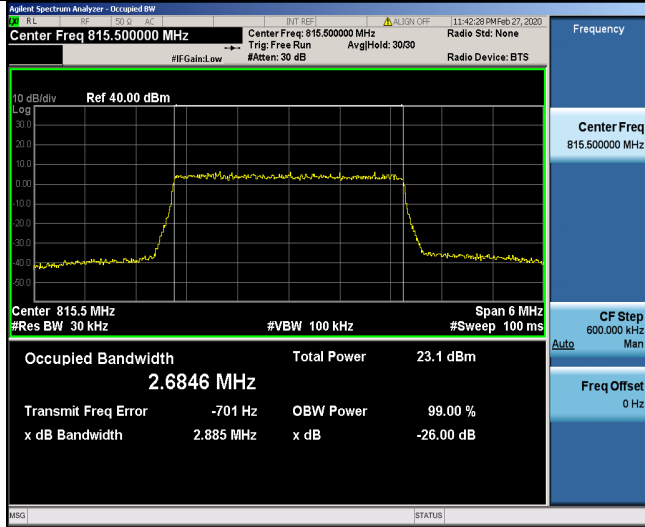

Band26 3MHz 16QAM 26740 15RB#0

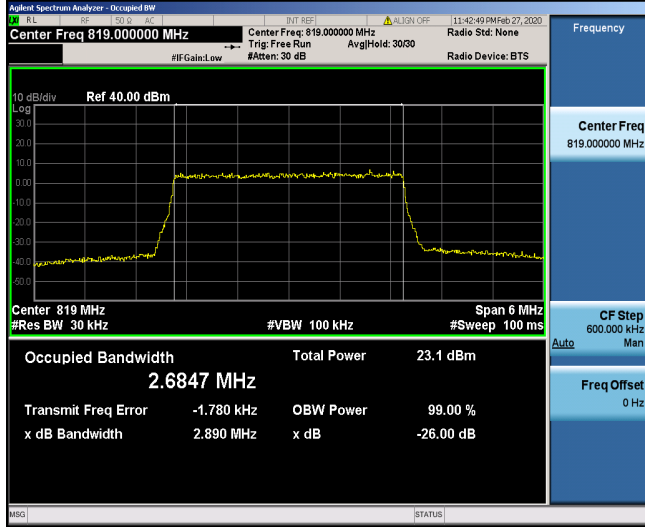

Band26 3MHz 16QAM 26775 15RB#0

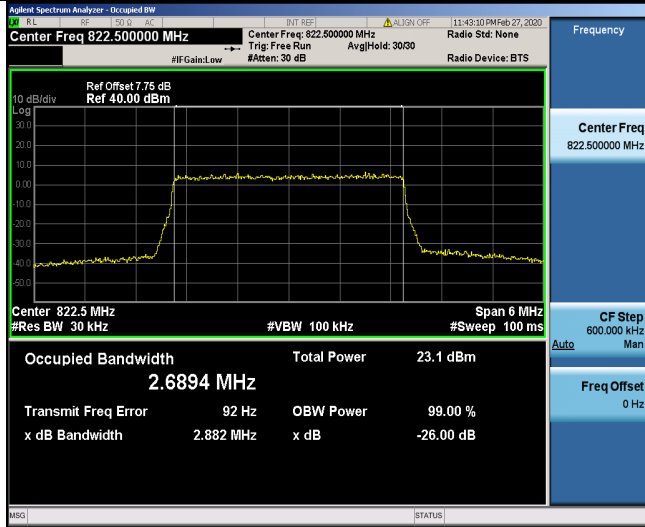

Band26 5MHz QPSK 26715 25RB#0

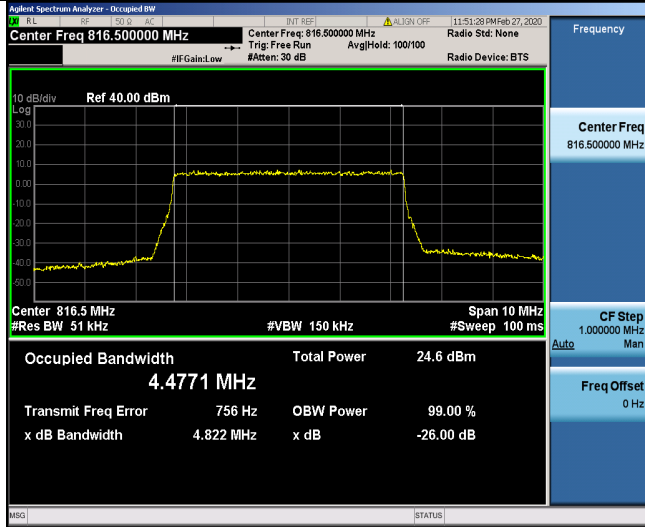

Band26 5MHz QPSK 26740 25RB#0

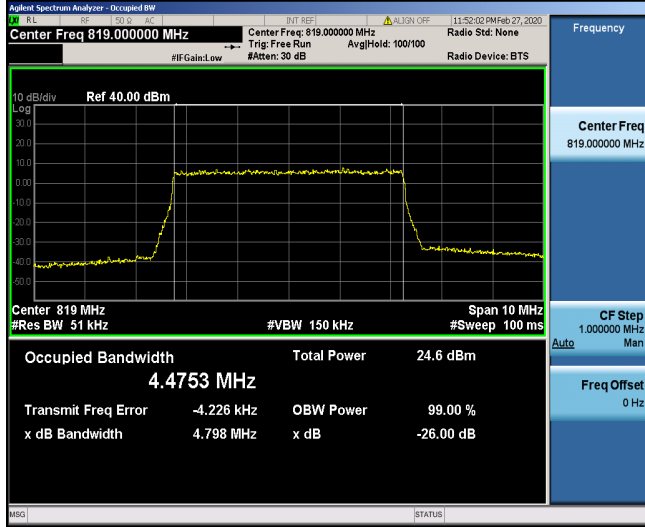

Band26 5MHz QPSK 26765 25RB#0

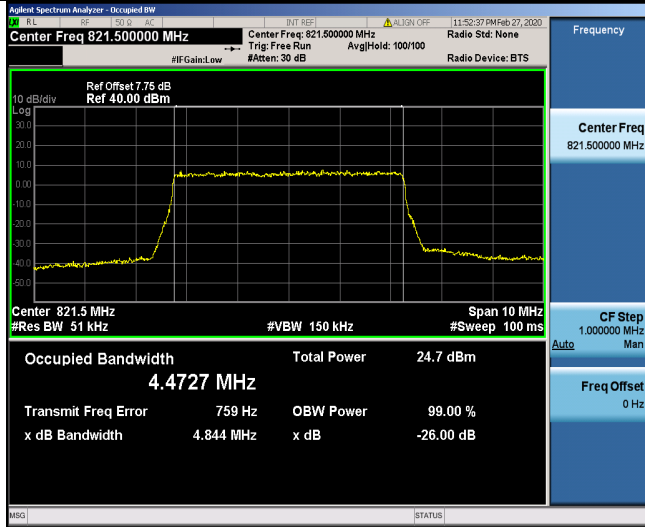

Band26 5MHz 16QAM 26715 25RB#0

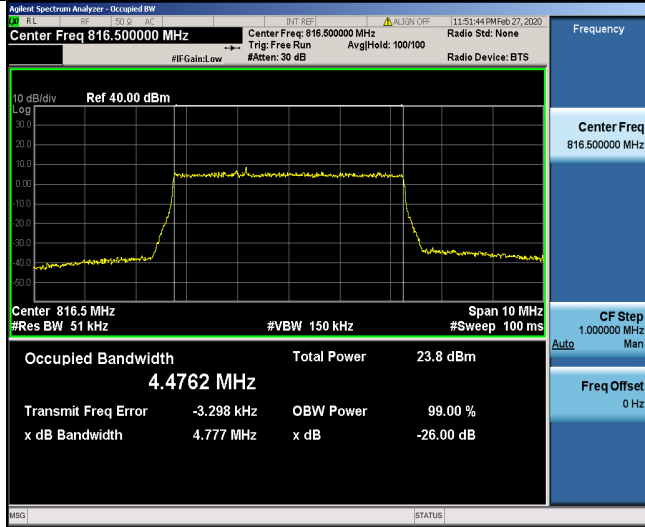

Band26 5MHz 16QAM 26740 25RB#0

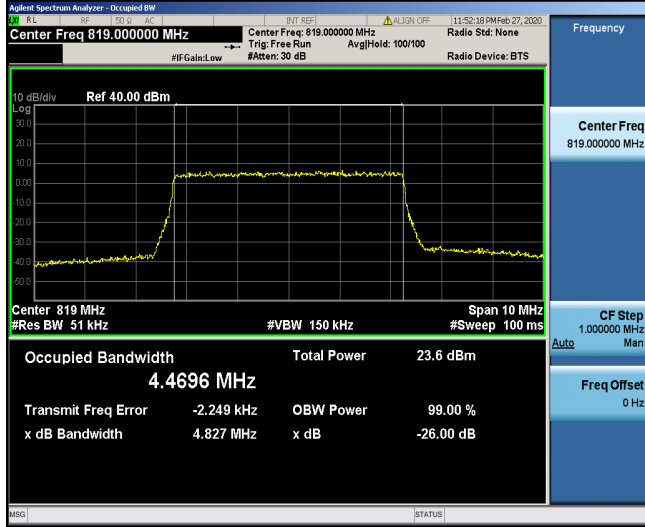

Band26 5MHz 16QAM 26765 25RB#0

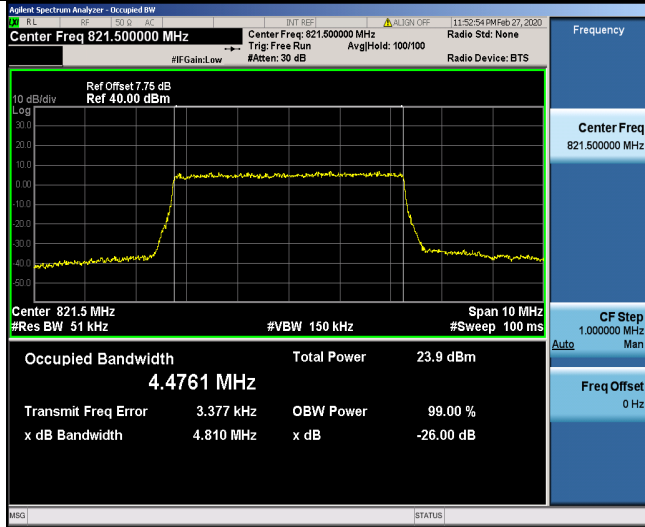

Band26 10MHz QPSK 26740 50RB#0

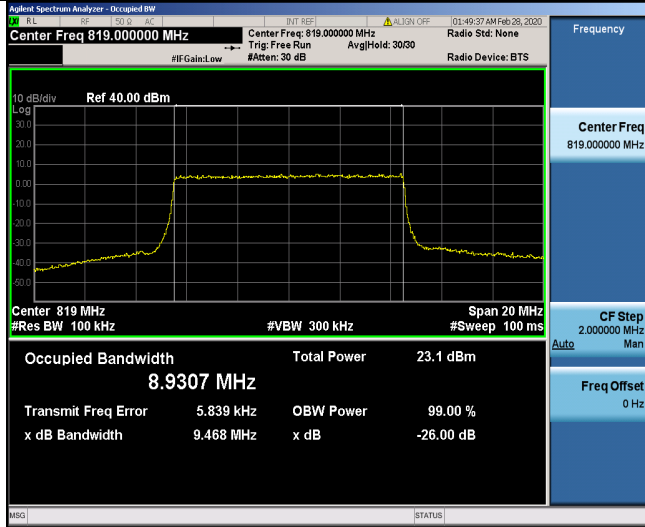

Band26 10MHz 16QAM 26740 50RB#0

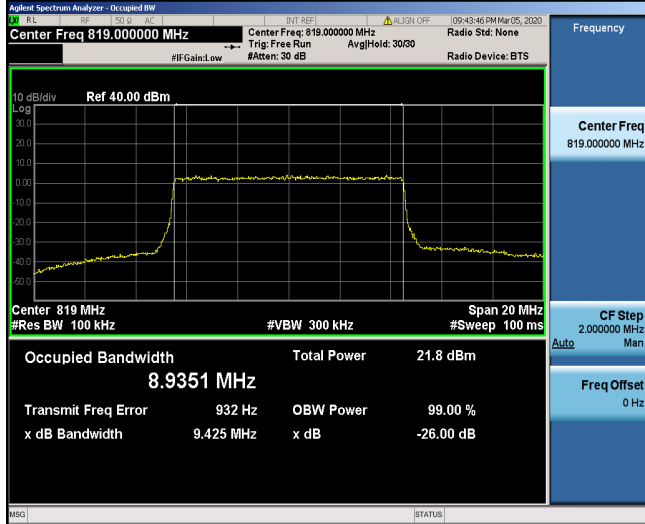

5.4. Spurious Emission at Antenna Terminal

5.4.1. Test Standard

FCC: CFR Part 2.1051, CFR Part 90.691

5.4.2. Test Limit

The radio frequency voltage or power generated within the equipment and appearing on a spurious frequency shall be checked at the equipment output terminals when properly loaded with a suitable artificial antenna. Curves or equivalent data shall show the magnitude of each harmonic and other spurious emission that can be detected when the equipment is operated under the conditions specified in FCC 2.1049 as appropriate. The magnitude of spurious emissions which are attenuated more than 20 dB below the permissible value need not be specified.

(a) Out of band emissions. The power of any emission outside of the authorized operating frequency ranges must be attenuated below the transmitting power (P) by a factor of at least $43 + 10 \log(P)$ dB. For all power levels +30dBm to 0dBm, this becomes a constant specification of -13dBm.

FCC 90.691

(a) Out-of-band emission requirement shall apply only to the "outer" channels included in an EA license and to spectrum adjacent to interior channels used by incumbent licensees. The emission limits are as follows:

(1) For any frequency removed from the EA licensee's frequency block by up to and including 37.5 kHz, the power of any emission shall be attenuated below the transmitter power (P) in watts by at least $116 \log_{10}(f/6.1)$ decibels or $50 + 10 \log_{10}(P)$ decibels or 80 decibels, whichever is the lesser attenuation, where f is the frequency removed from the center of the outer channel in the block in kilohertz and where f is greater than 12.5 kHz.

(2) For any frequency removed from the EA licensee's frequency block greater than 37.5 kHz, the power of any emission shall be attenuated below the transmitter power (P) in watts by at least $43 + 10 \log_{10}(P)$ decibels or 80 decibels, whichever is the lesser attenuation, where f is the frequency removed from the center of the outer channel in the block in kilohertz and where f is greater than 37.5 kHz.

The power of any emission shall be attenuated below the mean output power P (dBW) by at least $43 + 10 \log_{10}(p)$, measured in a 100 kHz bandwidth for frequencies less than or equal to 1 GHz, and in a 1 MHz bandwidth for frequencies greater than 1 GHz.

5.4.3. Test Procedure

1. Connect the equipment as shown in the above diagram.
2. Set the spectrum analyzer to measure peak hold with the required settings.
3. Set the signal generator to a known output power and record the path loss in dB (LOSS) for frequencies up to the tenth harmonic of the EUT's carrier frequency.
 $LOSS = \text{Generator Output Power (dBm)} - \text{Analyzer reading (dBm)}$.
4. Replace the signal generator with the EUT.
5. Adjust the settings of the Wideband Radio Communication Tester (CMW500) to set the EUT to its maximum power at the required channel.
6. Set the spectrum analyzer to measure peak hold with the required settings.

Offset the spectrum analyzer reference level by the path loss measured above.

7. Measure and record all spurious emissions up to the tenth harmonic of the carrier frequency.

8. Measurements are to be performed with the EUT set to the low, middle and high channel of each frequency band.

9. If necessary steps 6 and 7 may be performed with the spectrum analyzer set to average detector.

(Note: Step 3 above is performed prior to testing and LOSS is recorded by test software. Steps 2, 6, and 7 above are performed with test software.)

5.4.4. Test Data

Band26 1.4MHz QPSK 26697 1RB

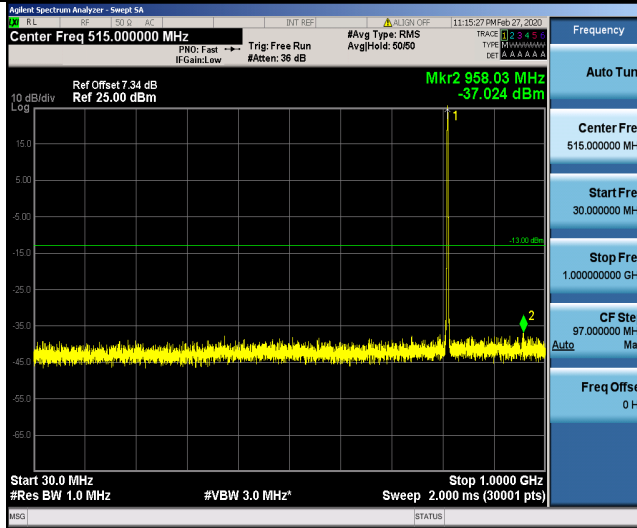

Band26 1.4MHz QPSK 26697 1RB

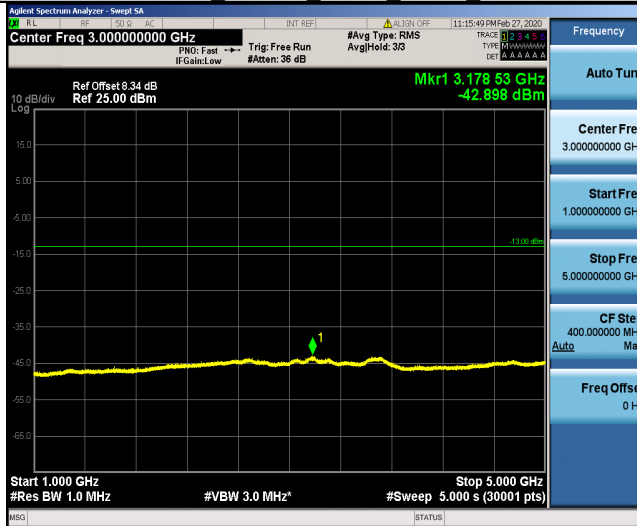

Band26 1.4MHz QPSK 26697 1RB

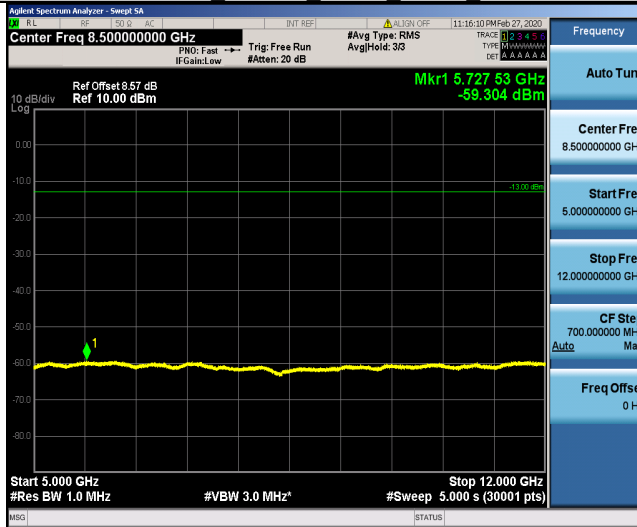

Band26 1.4MHz QPSK 26740 1RB

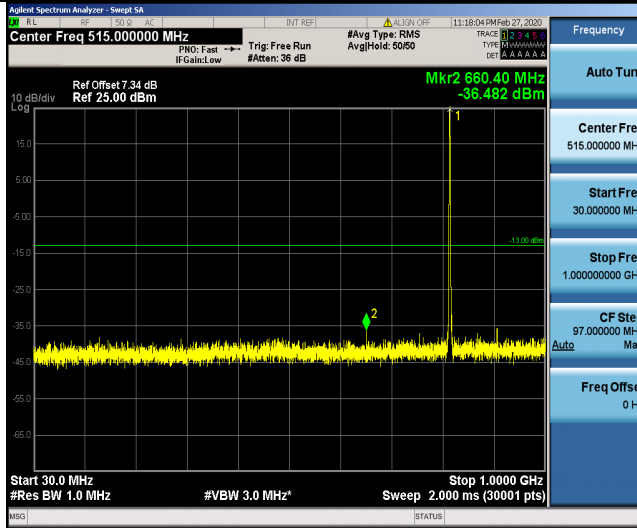

Band26 1.4MHz QPSK 26740 1RB

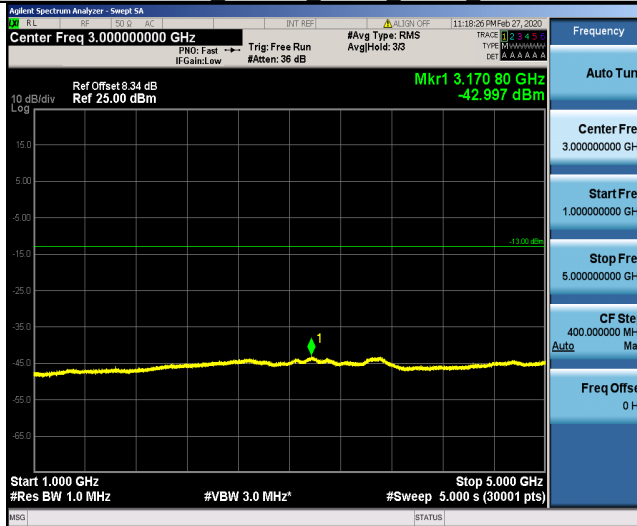

Band26 1.4MHz QPSK 26740 1RB

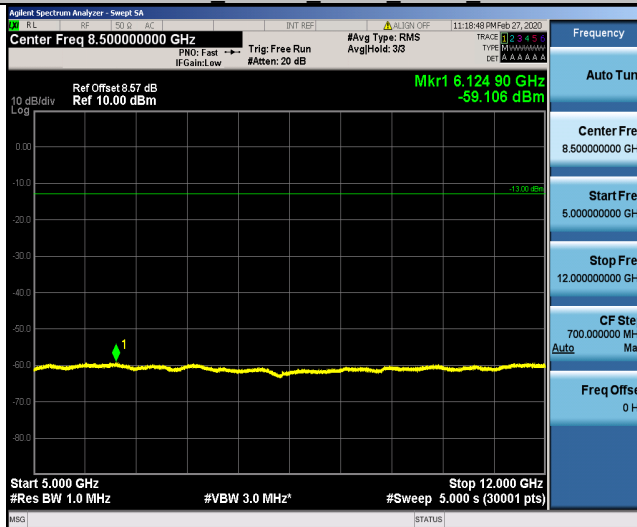

Band26 1.4MHz QPSK 26783 1RB

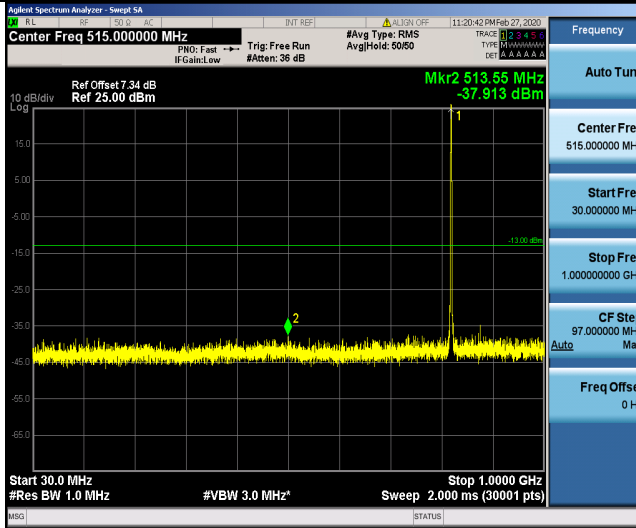

Band26 1.4MHz QPSK 26783 1RB

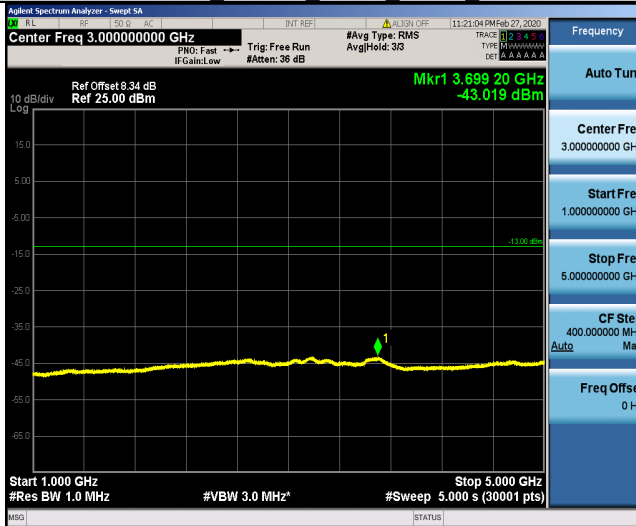

Band26 1.4MHz QPSK 26783 1RB

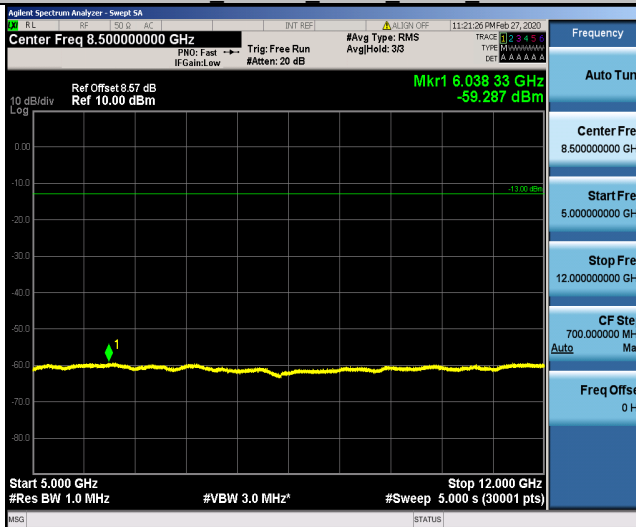

Band26 1.4MHz 16QAM 26697 1RB

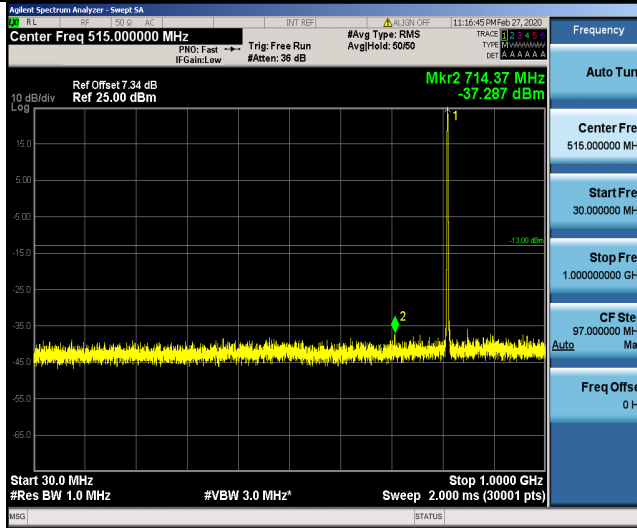

Band26 1.4MHz 16QAM 26697 1RB

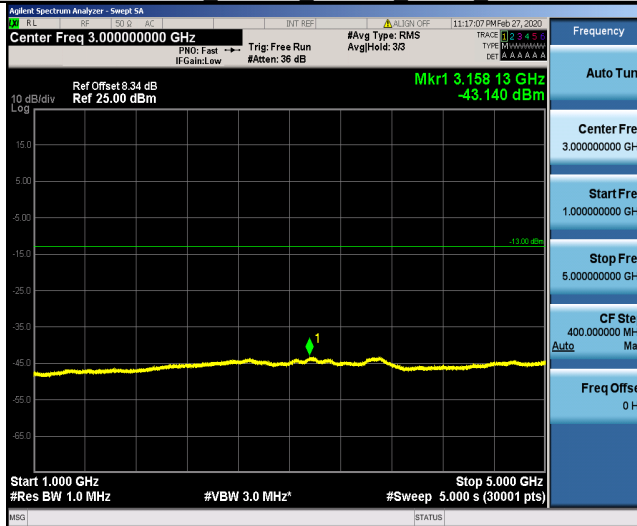

Band26 1.4MHz 16QAM 26697 1RB



Band26 1.4MHz 16QAM 26740 1RB

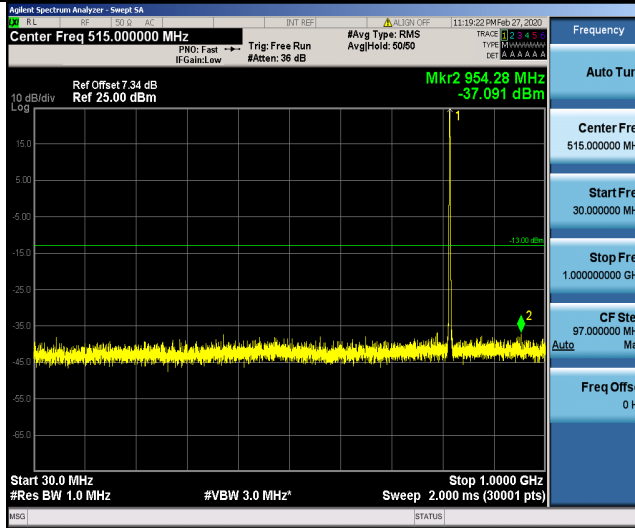

Band26 1.4MHz 16QAM 26740 1RB

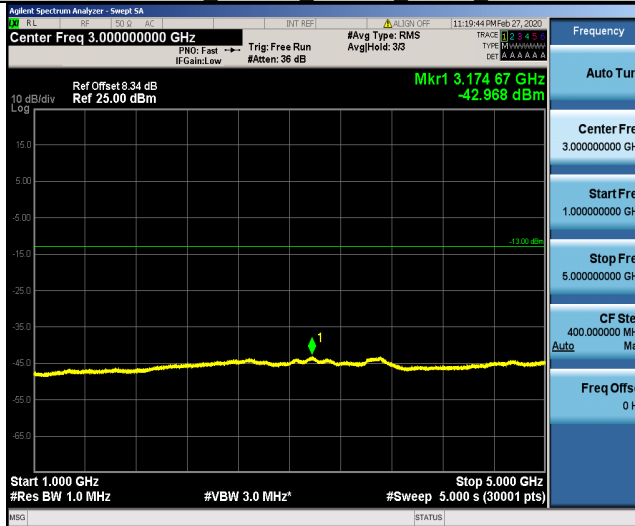

Band26 1.4MHz 16QAM 26740 1RB

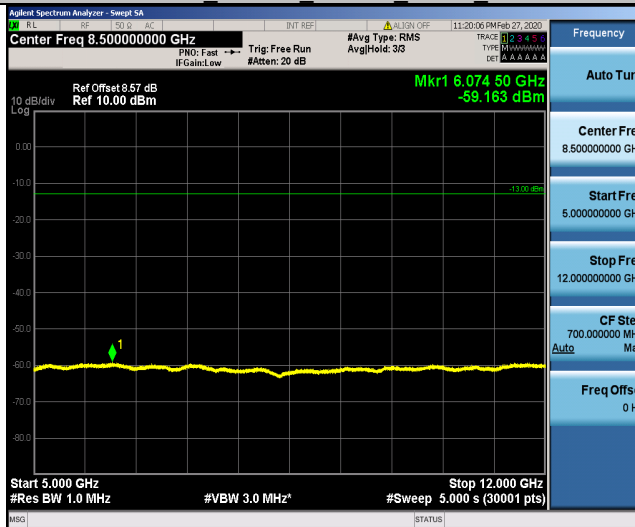

Band26 1.4MHz 16QAM 26783 1RB

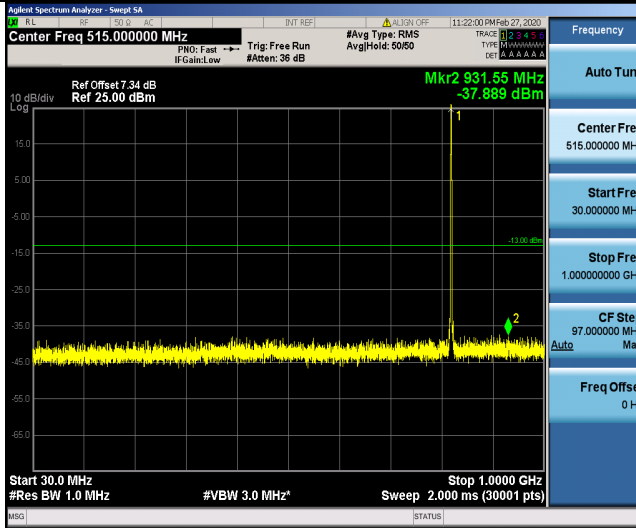

Band26 1.4MHz 16QAM 26783 1RB

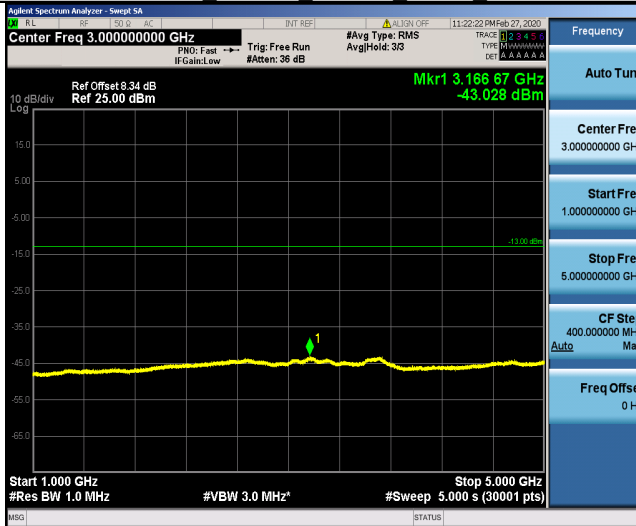

Band26 1.4MHz 16QAM 26783 1RB

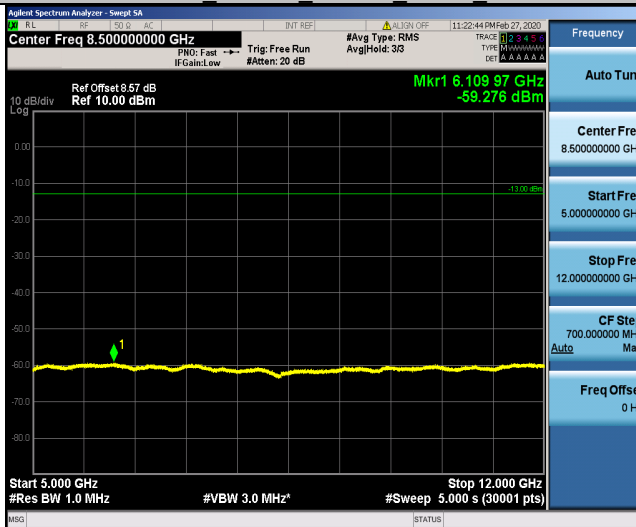

Band26 3MHz QPSK 26705 1RB

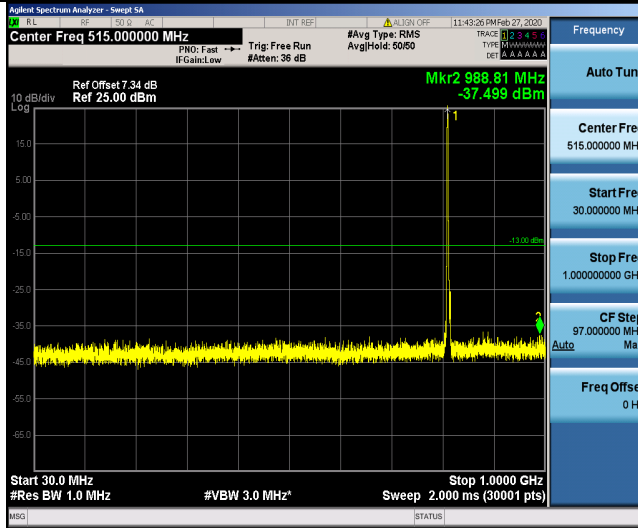

Band26 3MHz QPSK 26705 1RB

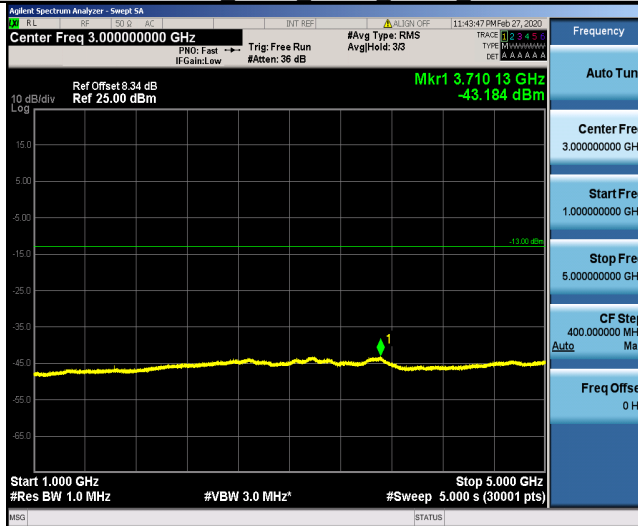

Band26 3MHz QPSK 26705 1RB

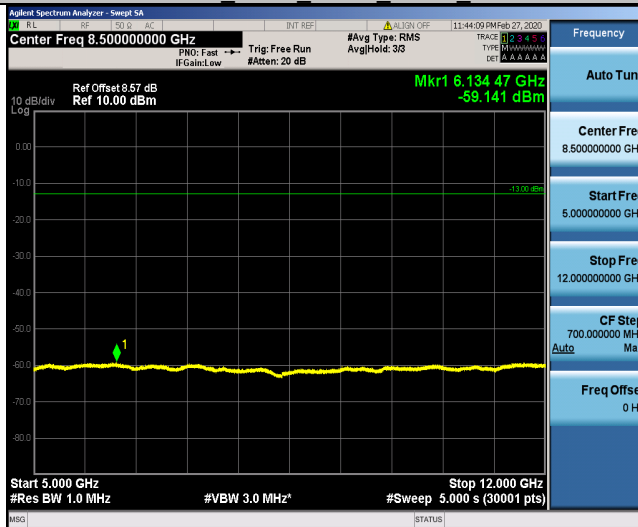

Band26 3MHz QPSK 26740 1RB

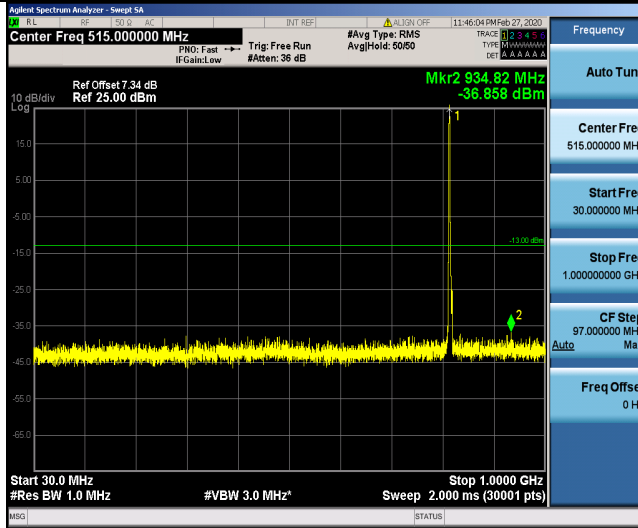

Band26 3MHz QPSK 26740 1RB

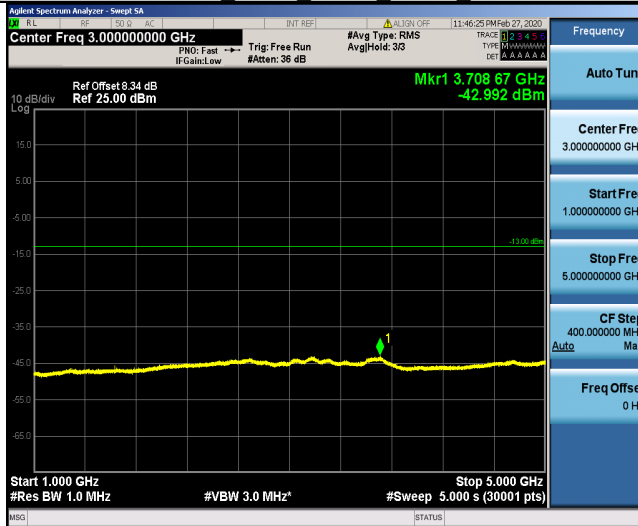

Band26 3MHz QPSK 26740 1RB

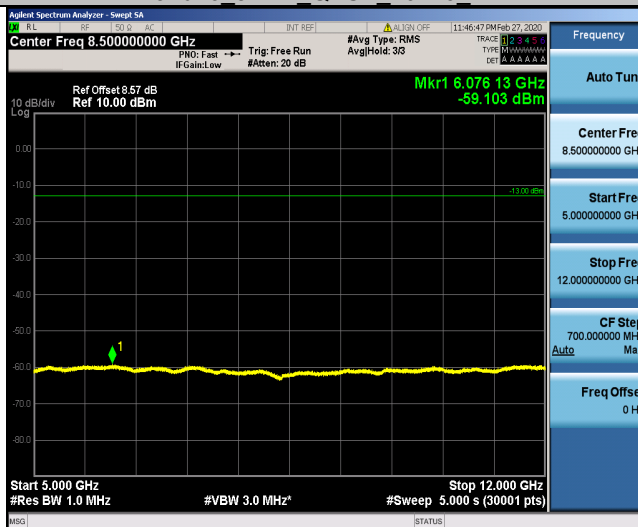

Band26 3MHz QPSK 26775 1RB

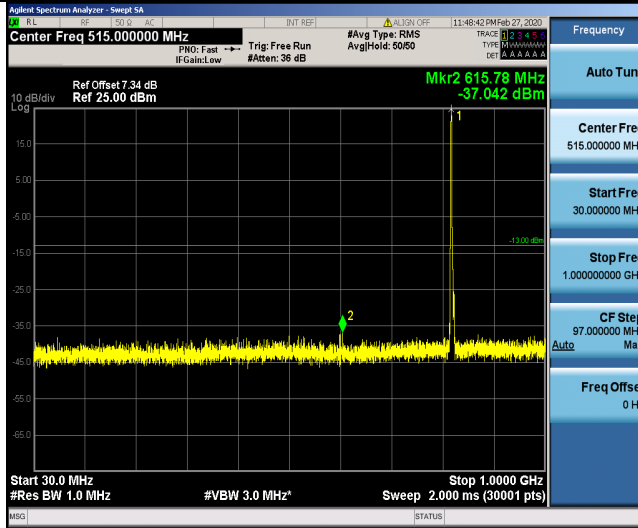

Band26 3MHz QPSK 26775 1RB

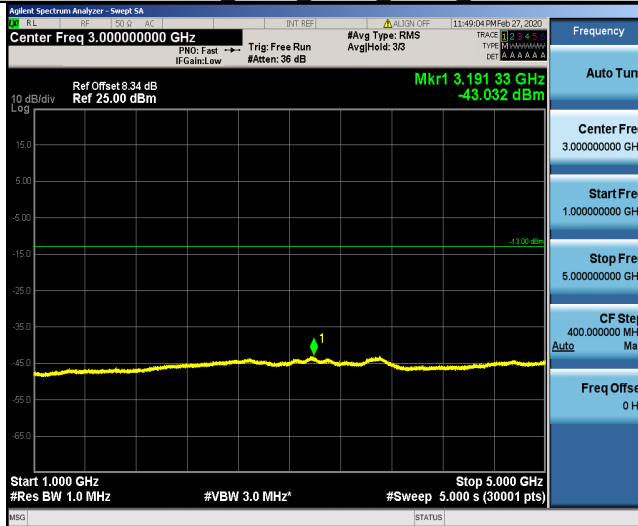

Band26 3MHz QPSK 26775 1RB

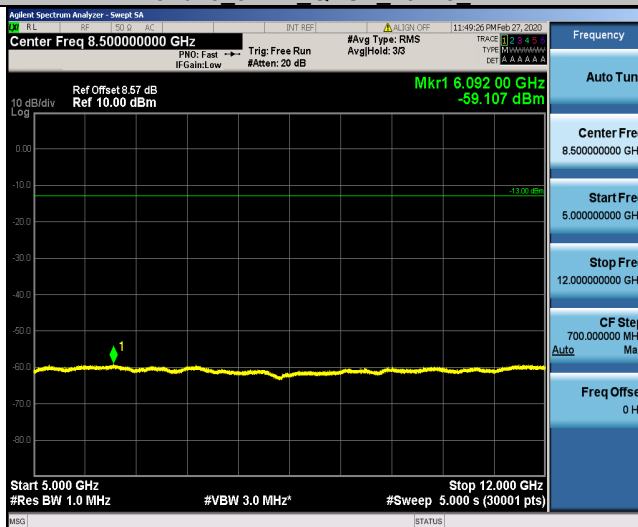

Band26 3MHz 16QAM 26705 1RB

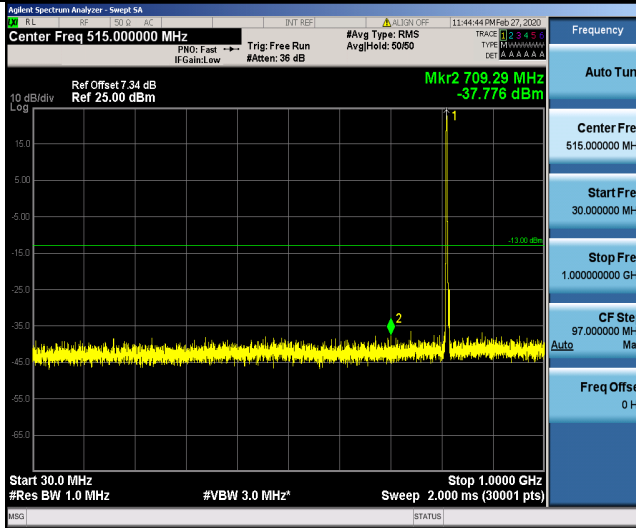

Band26 3MHz 16QAM 26705 1RB

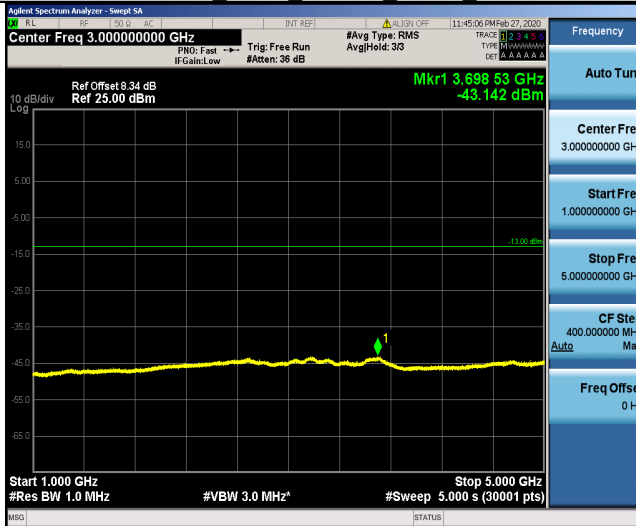

Band26 3MHz 16QAM 26705 1RB

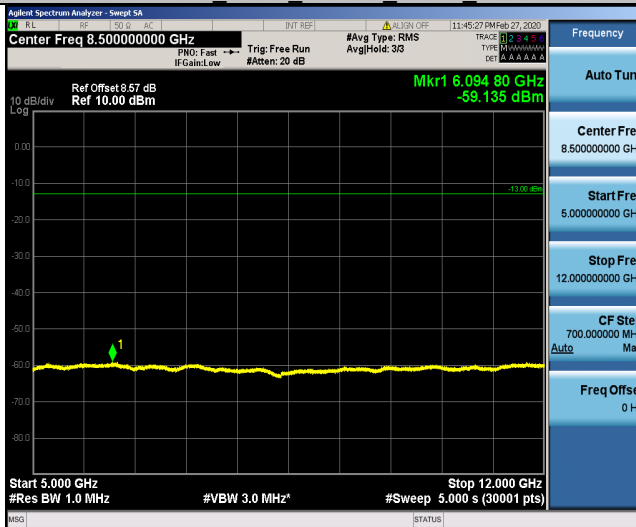

Band26 3MHz 16QAM 26740 1RB

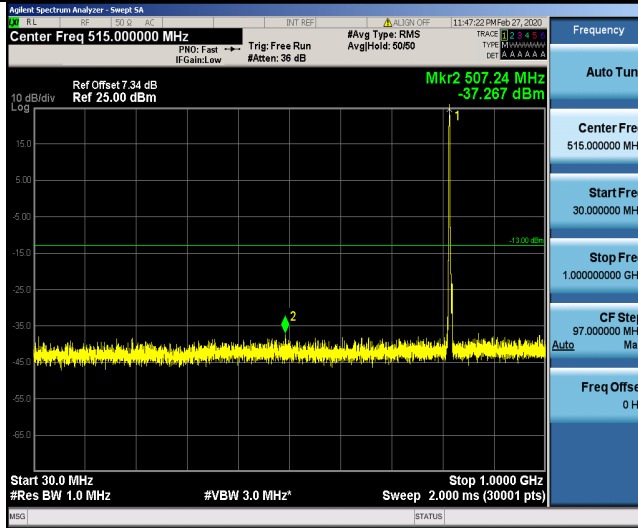

Band26 3MHz 16QAM 26740 1RB

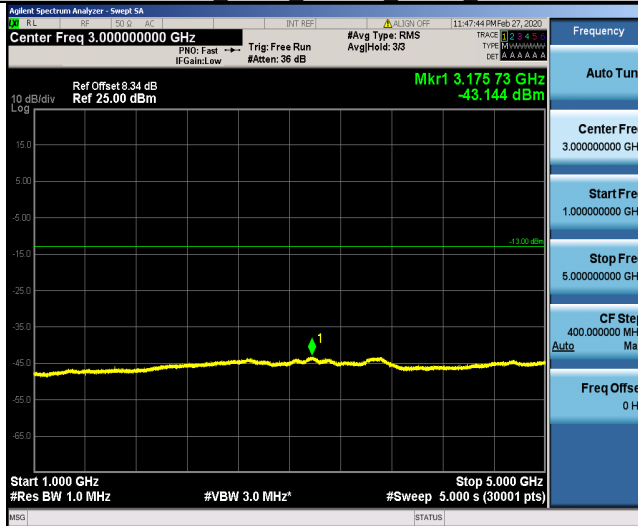

Band26 3MHz 16QAM 26740 1RB

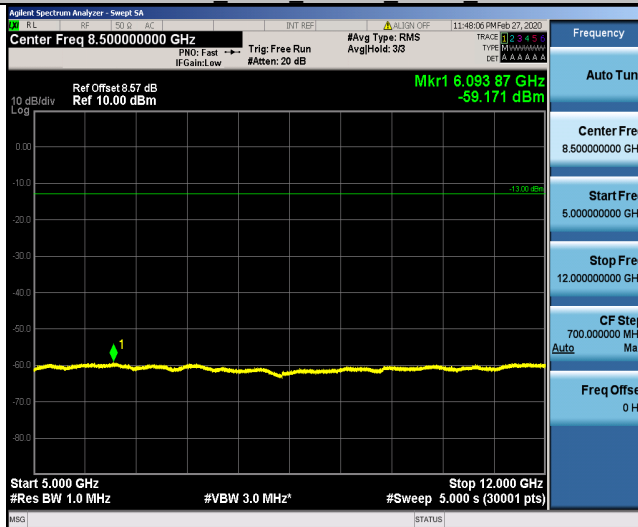

Band26 3MHz 16QAM 26775 1RB

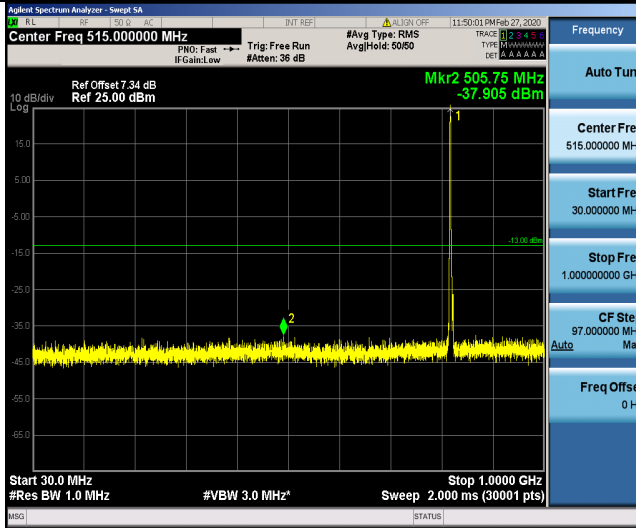

Band26 3MHz 16QAM 26775 1RB

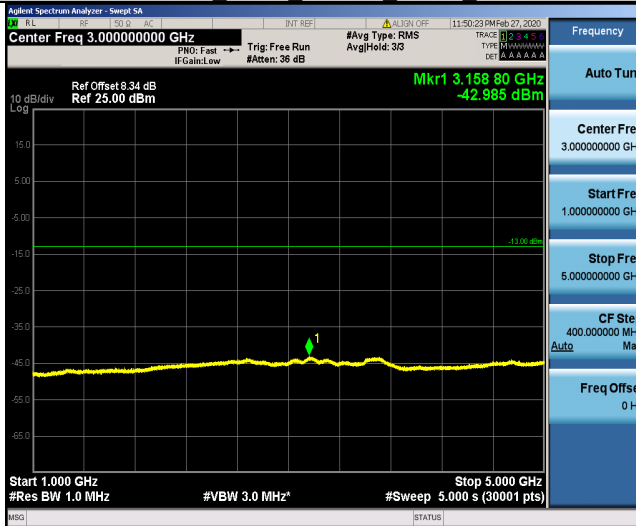

Band26 3MHz 16QAM 26775 1RB

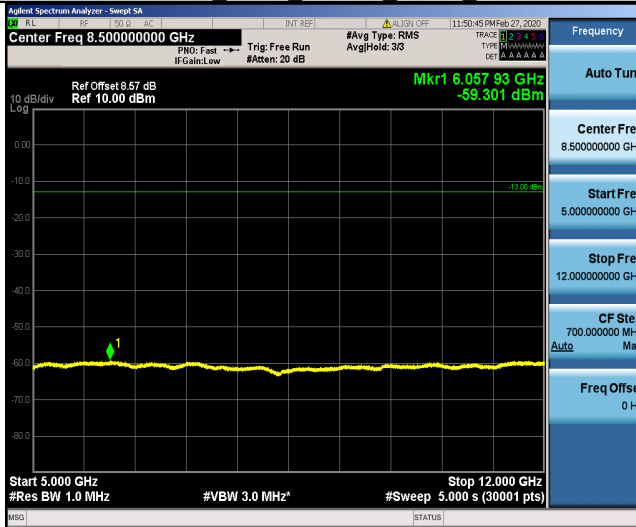

Band26 5MHz QPSK 26715 1RB

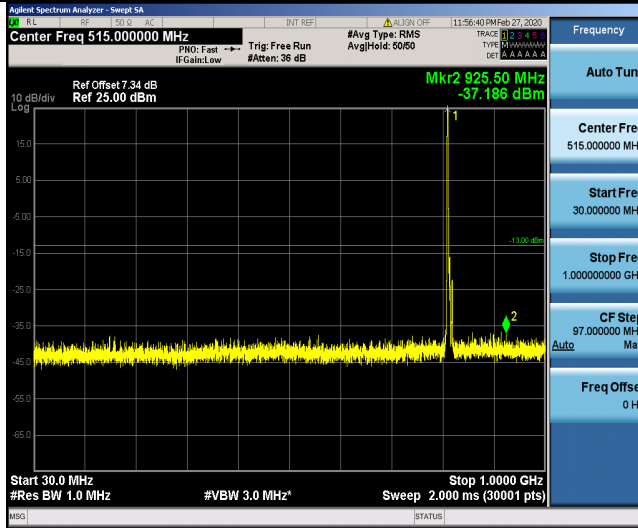

Band26 5MHz QPSK 26715 1RB

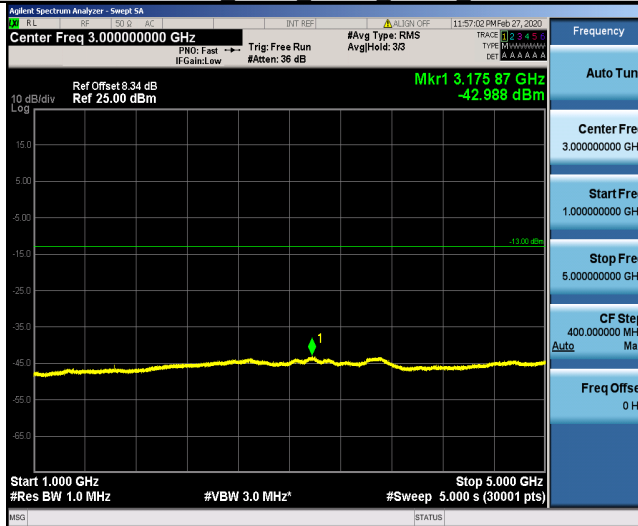

Band26 5MHz QPSK 26715 1RB

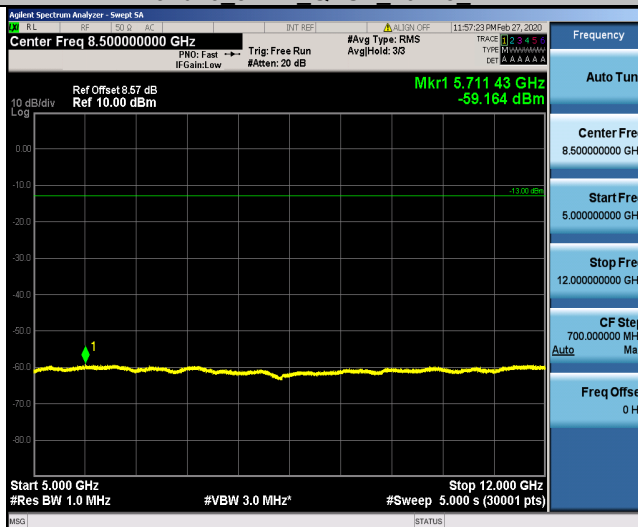

Band26 5MHz QPSK 26740 1RB

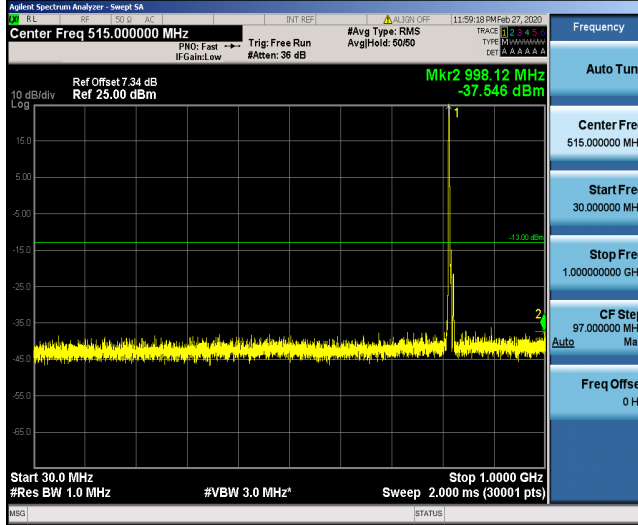

Band26 5MHz QPSK 26740 1RB

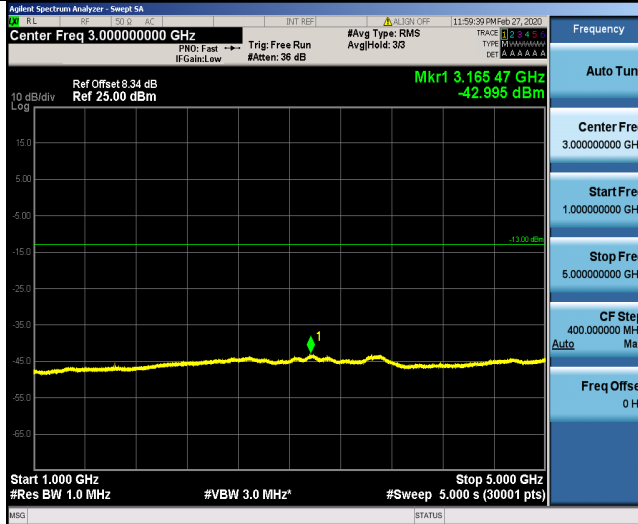

Band26 5MHz QPSK 26740 1RB

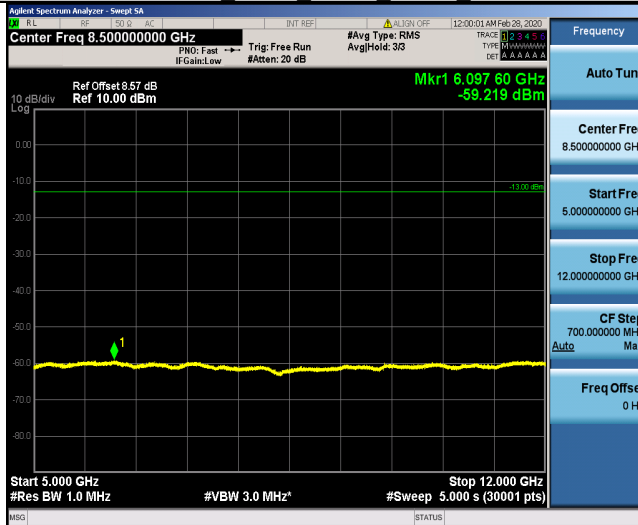

Band26 5MHz QPSK 26765 1RB

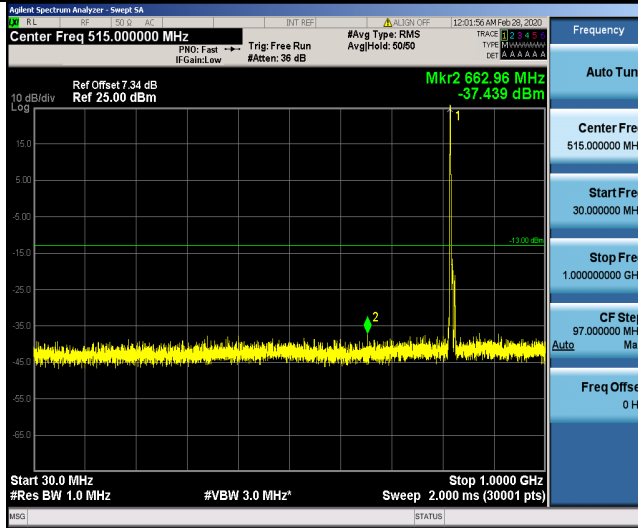

Band26 5MHz QPSK 26765 1RB

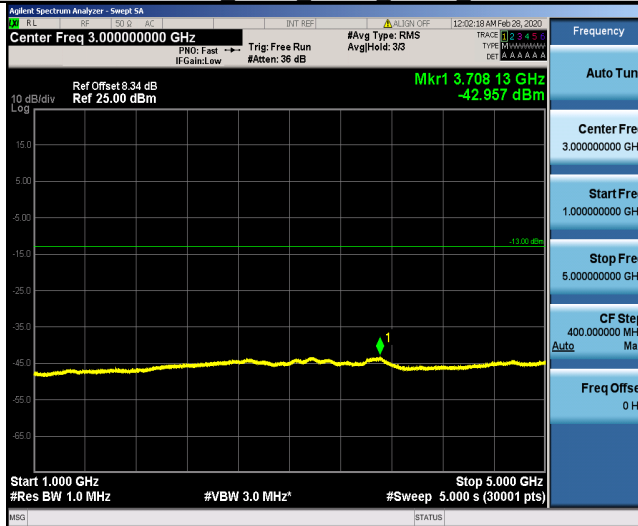

Band26 5MHz QPSK 26765 1RB

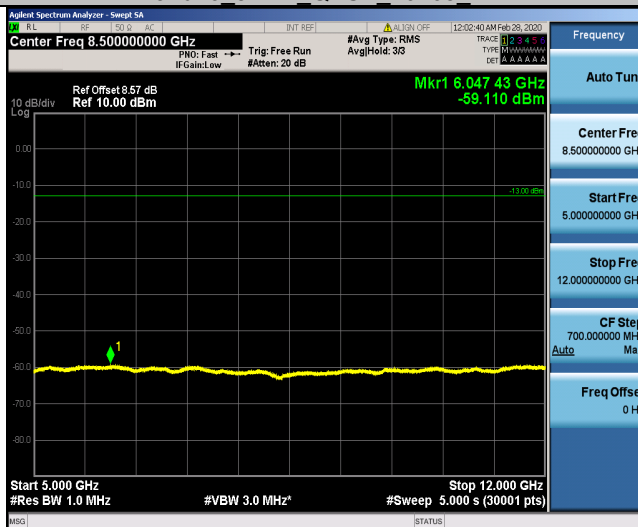

Band26 5MHz 16QAM 26715 1RB

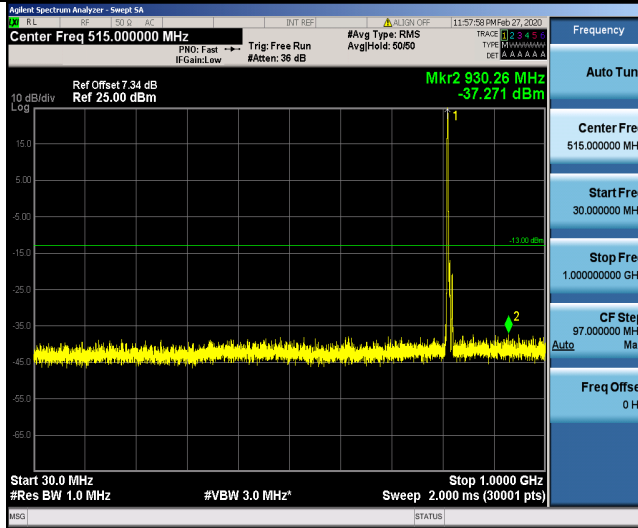

Band26 5MHz 16QAM 26715 1RB

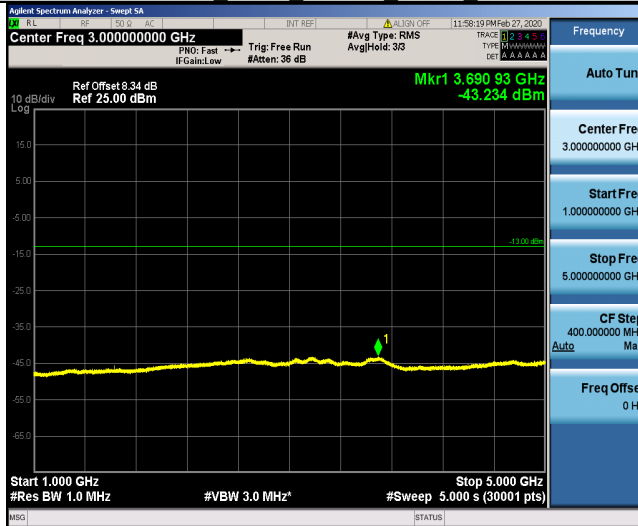

Band26 5MHz 16QAM 26715 1RB

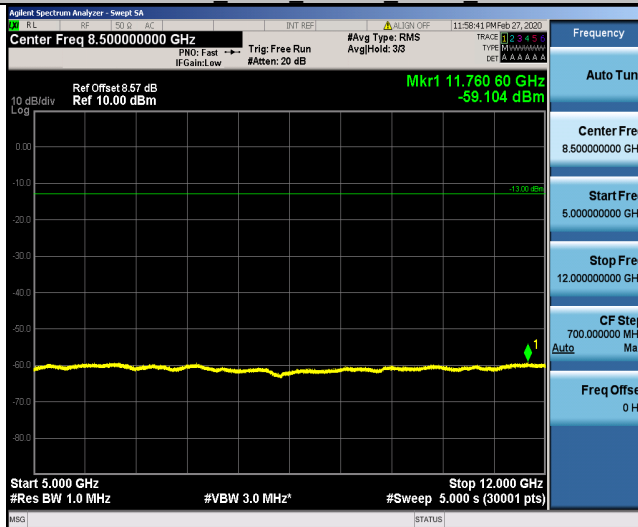

Band26 5MHz 16QAM 26740 1RB

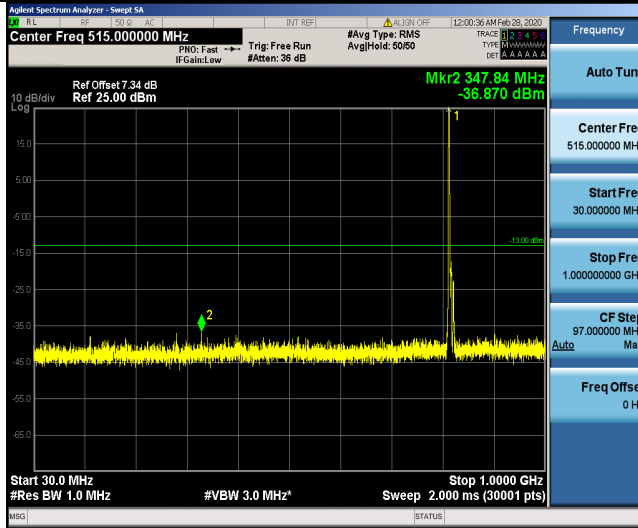

Band26 5MHz 16QAM 26740 1RB

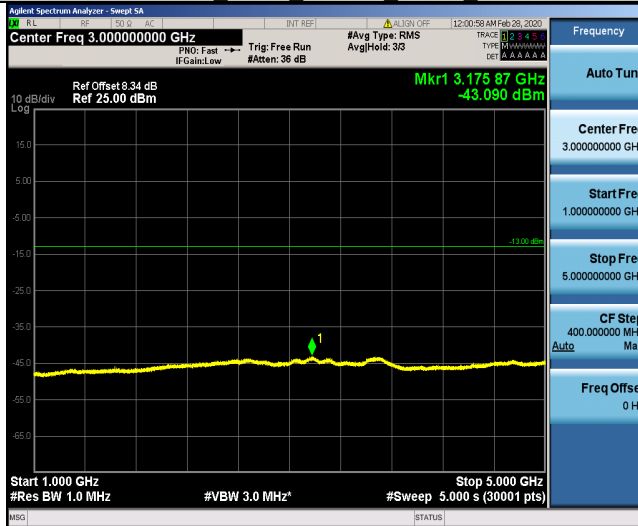

Band26 5MHz 16QAM 26740 1RB

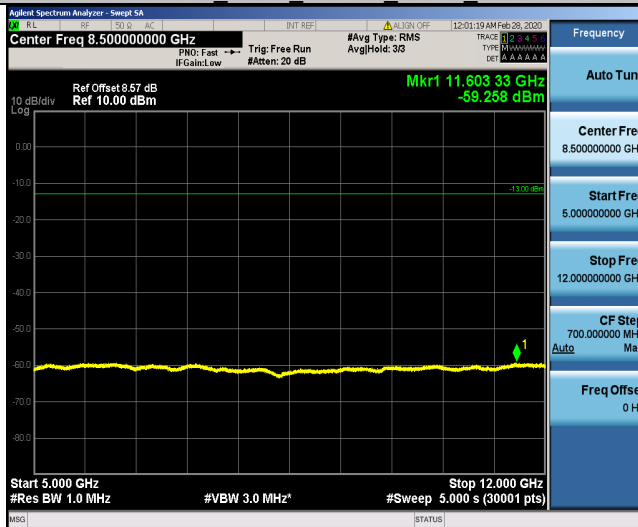

Band26 5MHz 16QAM 26765 1RB

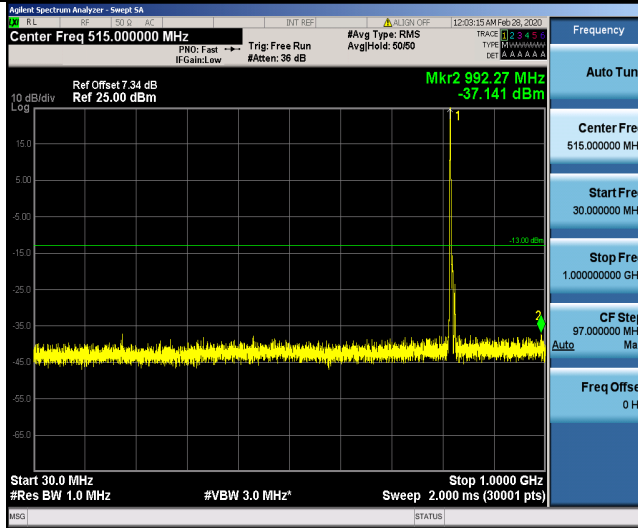

Band26 5MHz 16QAM 26765 1RB

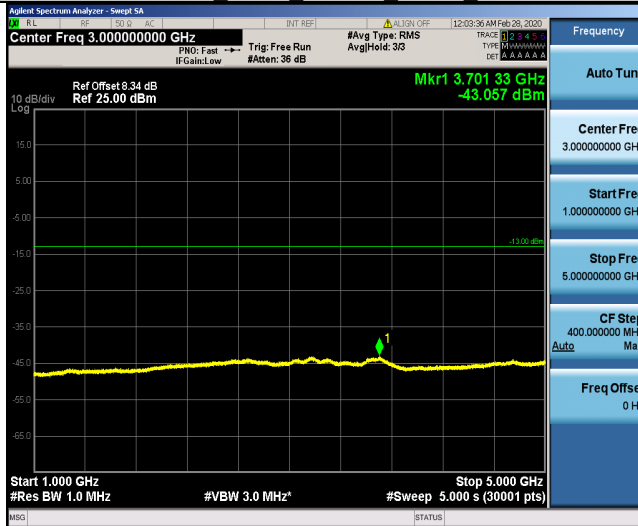

Band26 5MHz 16QAM 26765 1RB

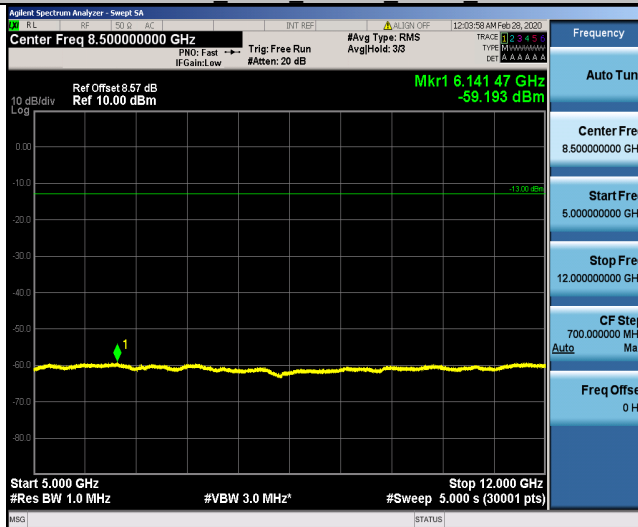

Band26 10MHz QPSK 26740 1RB

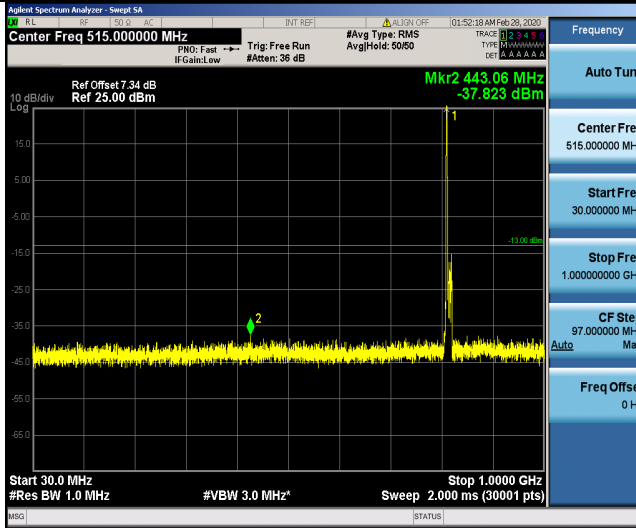

Band26 10MHz QPSK 26740 1RB

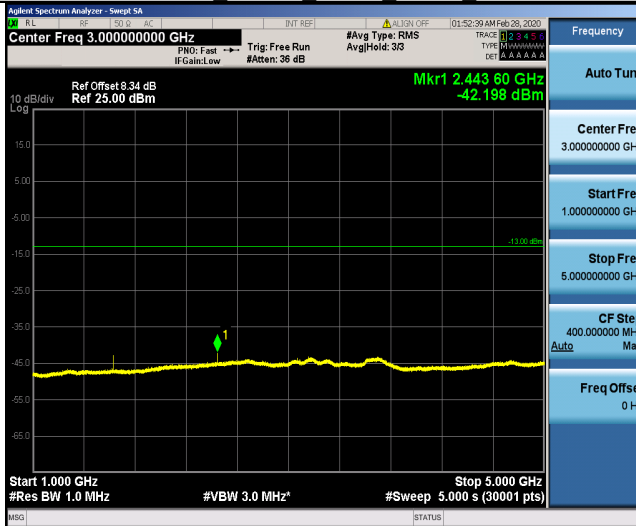

Band26 10MHz QPSK 26740 1RB

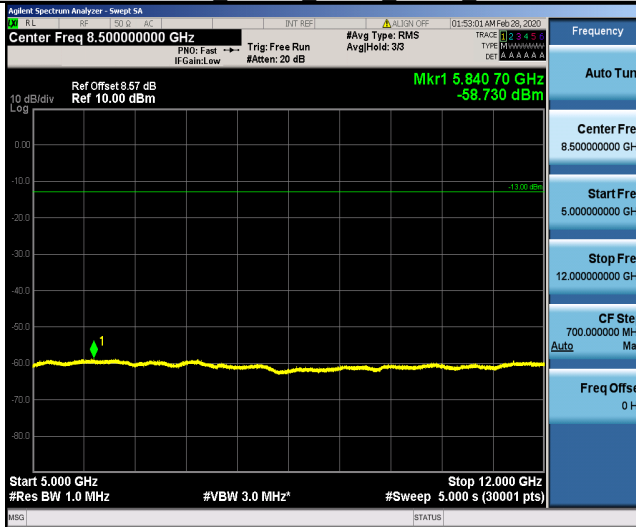

Band26 10MHz 16QAM 26740 1RB

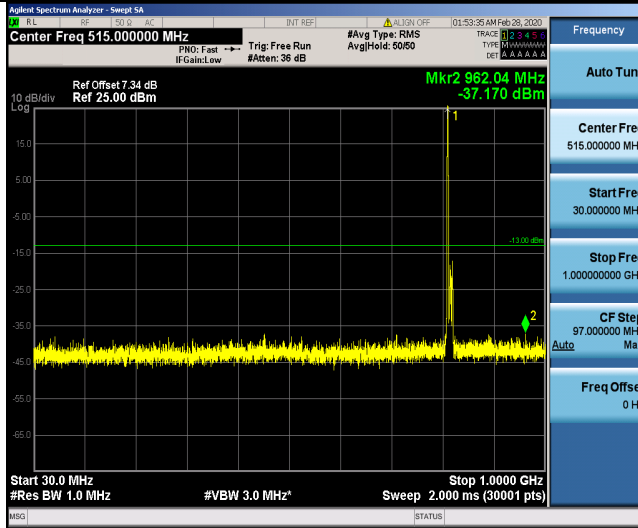

Band26 10MHz 16QAM 26740 1RB

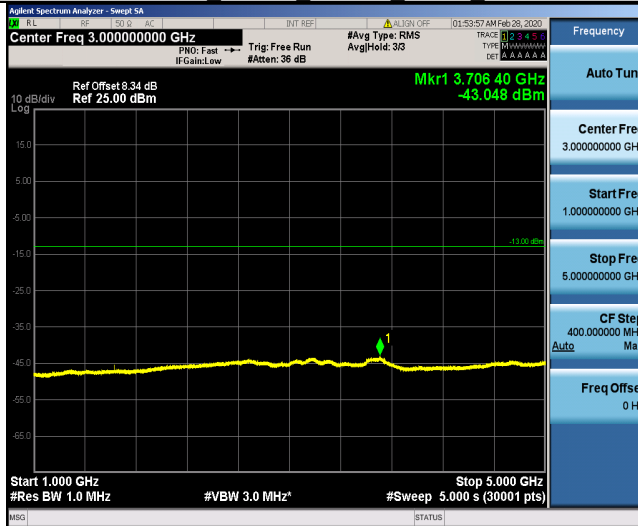

Band26 10MHz 16QAM 26740 1RB

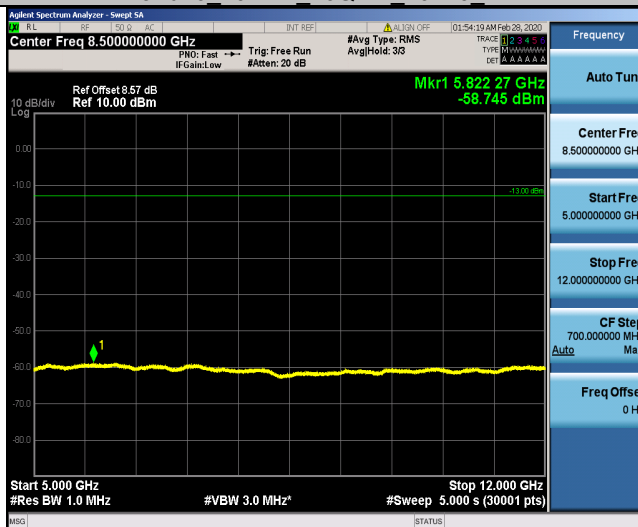

Band edge measurement
LTE Band 26:

Band26 1.4MHz QPSK 26697 1RB#0

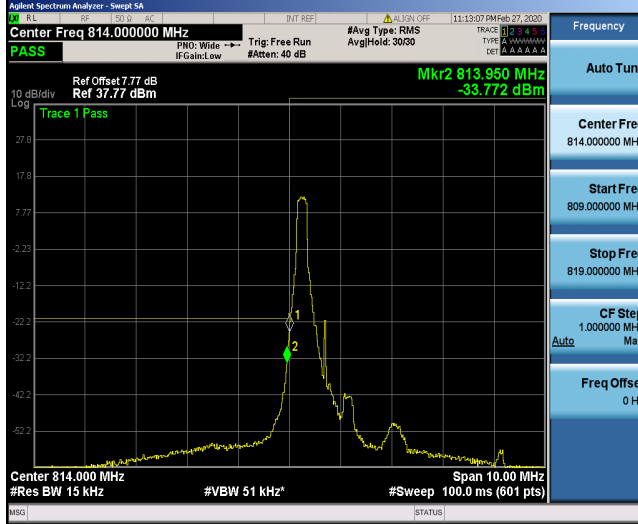

Band26 1.4MHz QPSK 26697 6RB#0



Band26 1.4MHz QPSK 26783 1RB#5

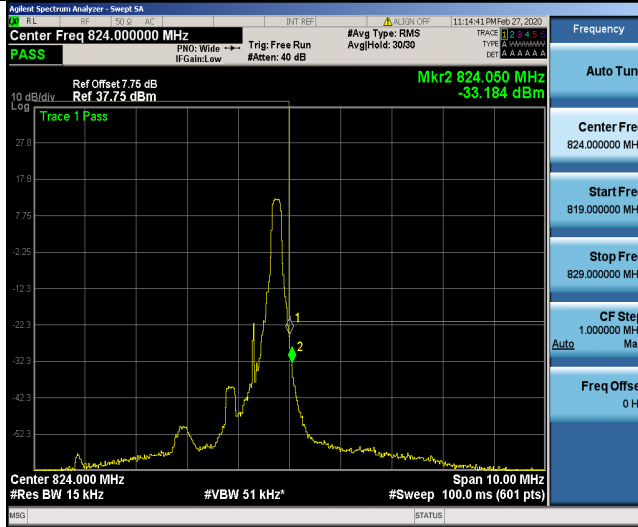

Band26 1.4MHz QPSK 26783 6RB#0

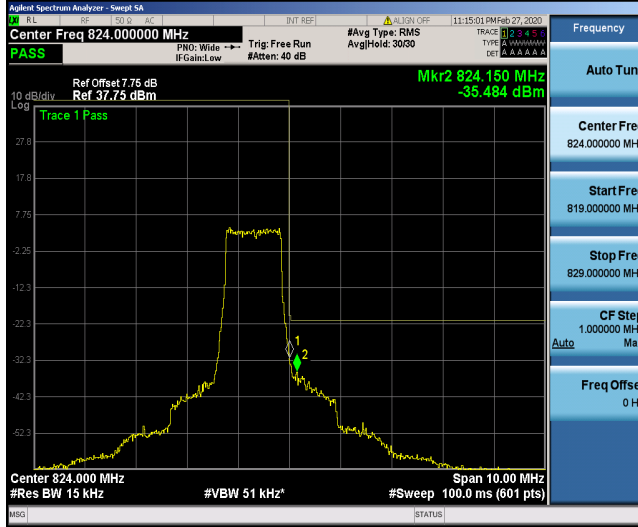

Band26 1.4MHz 16QAM 26697 1RB#0

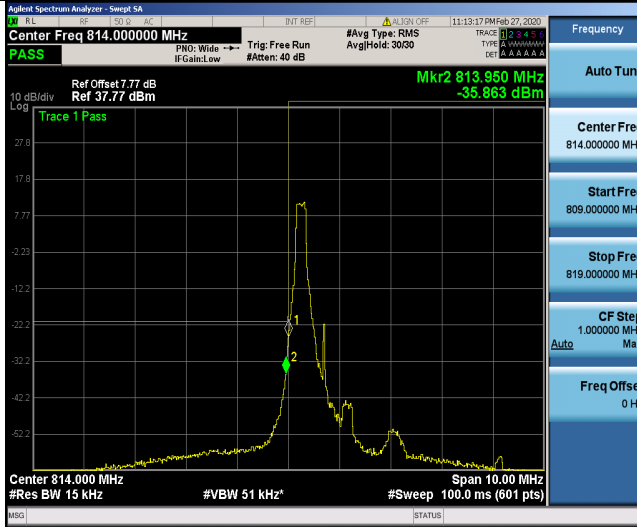

Band26 1.4MHz 16QAM 26697 6RB#0

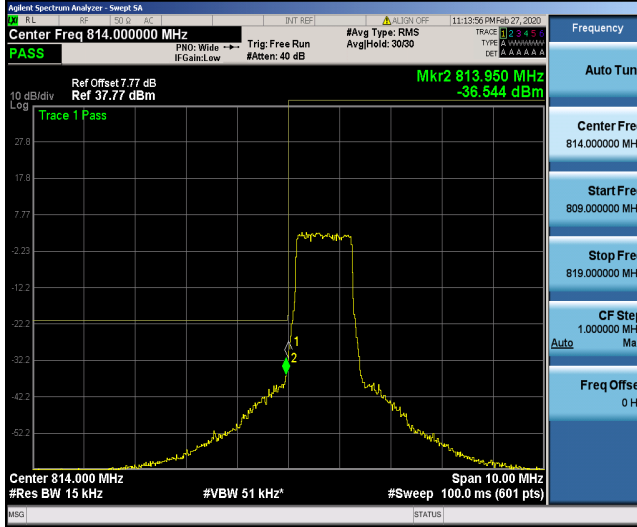

Band26 1.4MHz 16QAM 26783 1RB#5

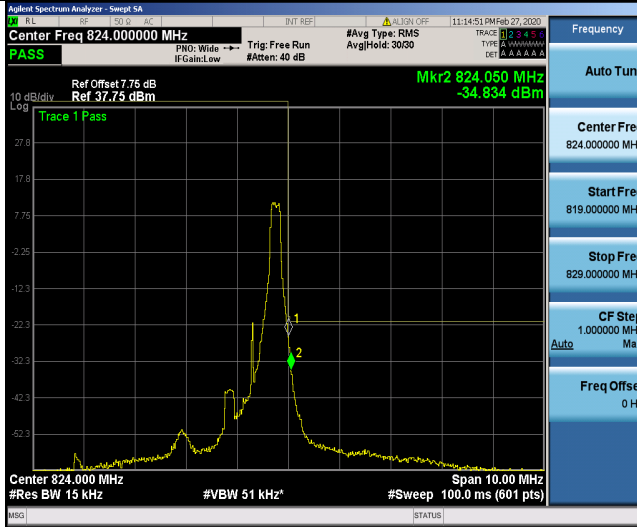

Band26 1.4MHz 16QAM 26783 6RB#0

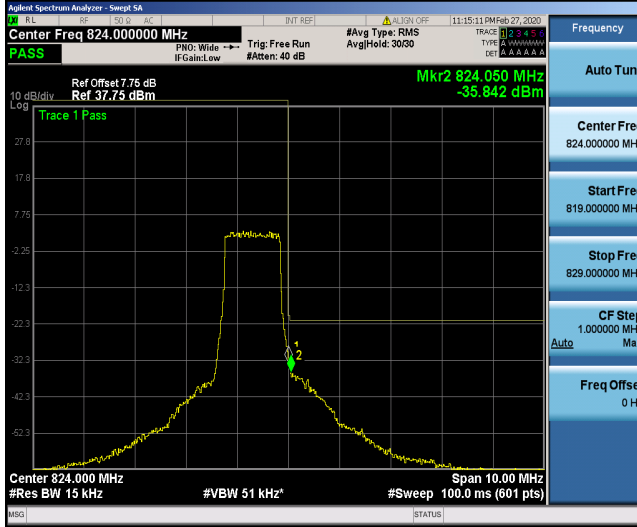

Band26 3MHz QPSK 26705 1RB#0

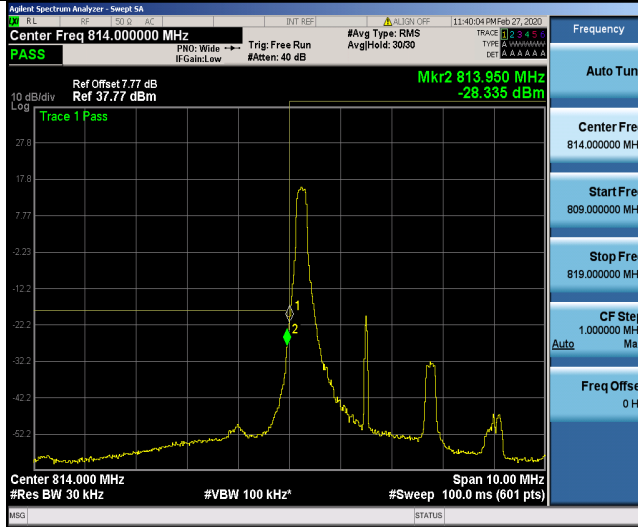

Band26 3MHz QPSK 26705 15RB#0

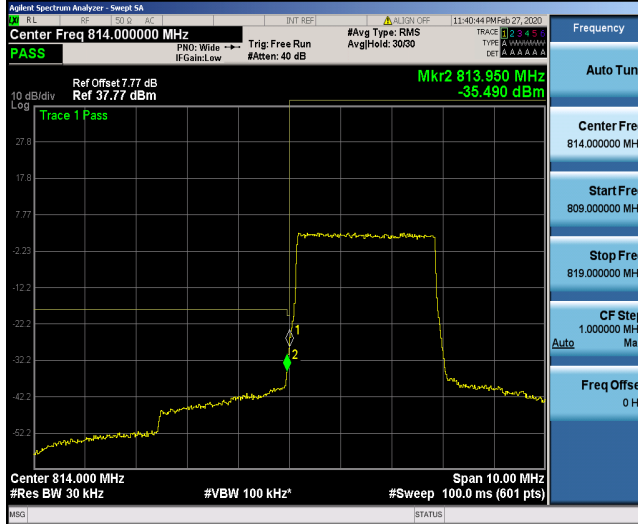

Band26 3MHz QPSK 26775 1RB#14

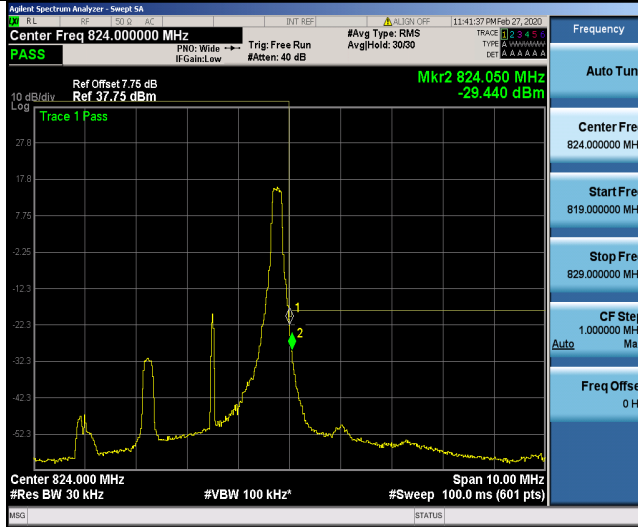

Band26 3MHz QPSK 26775 15RB#0

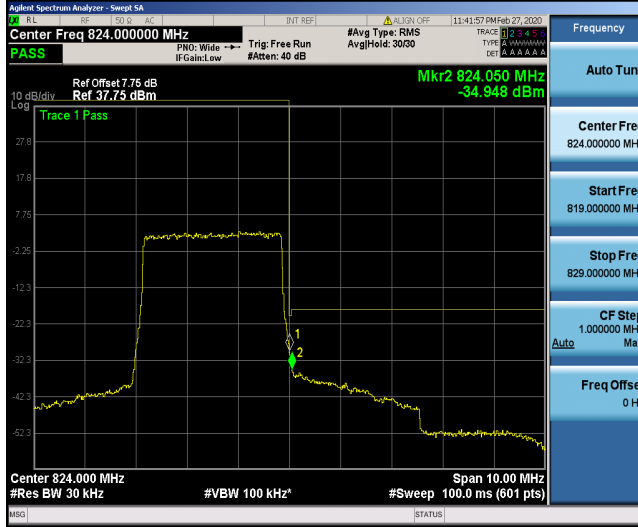

Band26 3MHz 16QAM 26705 1RB#0

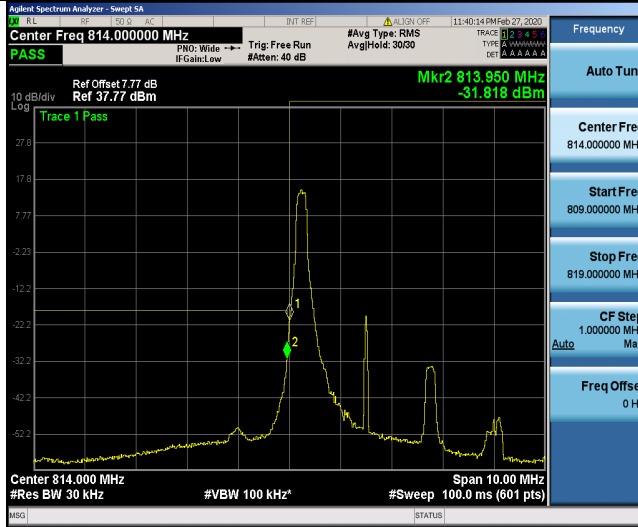

Band26 3MHz 16QAM 26705 15RB#0

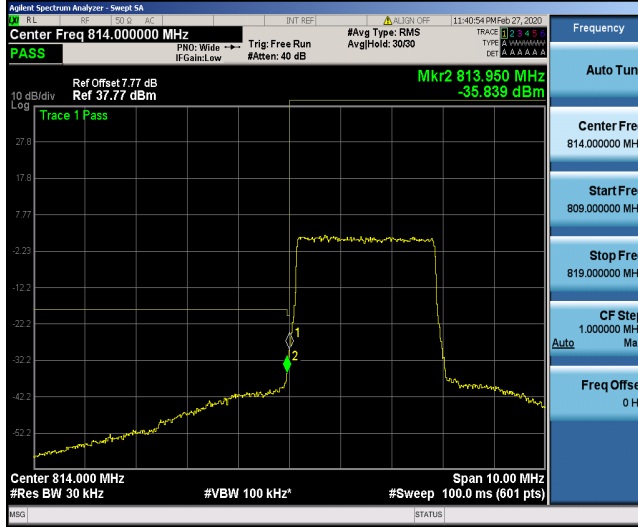

Band26 3MHz 16QAM 26775 1RB#14

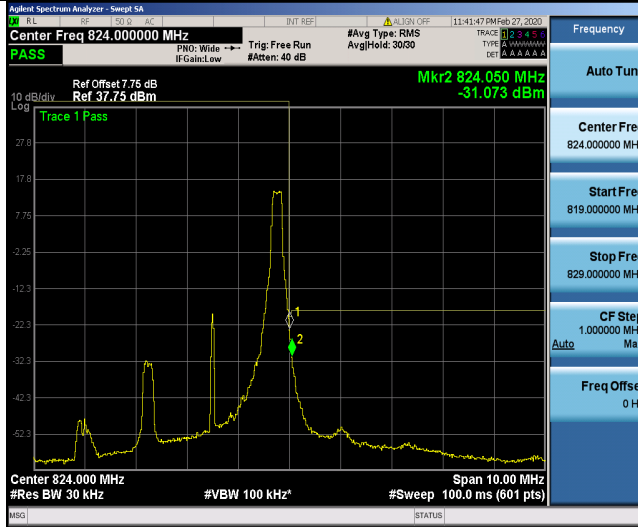

Band26 3MHz 16QAM 26775 15RB#0

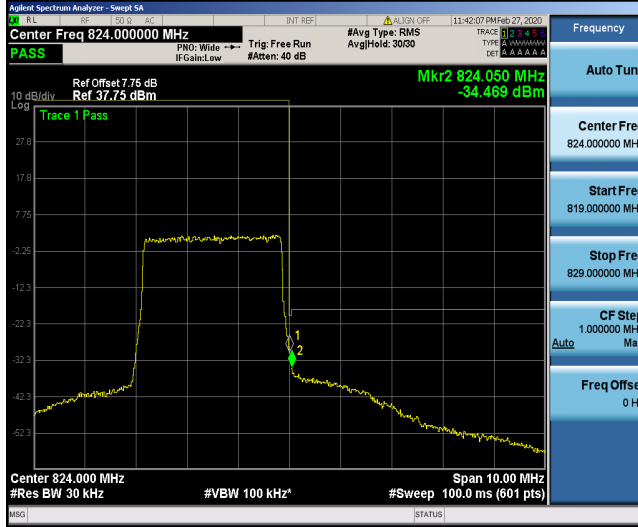

Band26 5MHz QPSK 26715 1RB#0

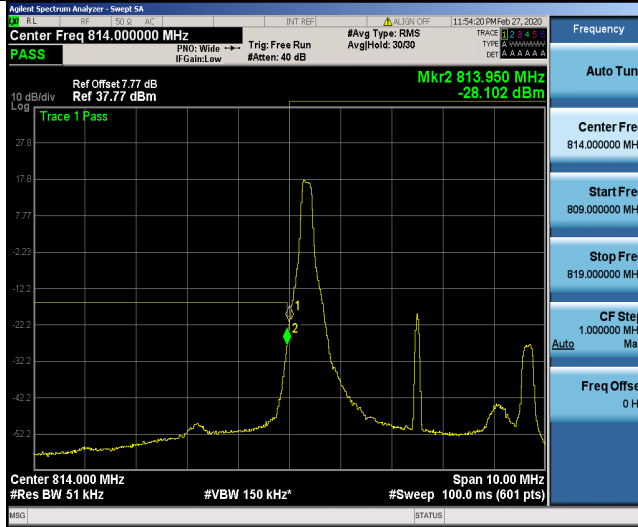

Band26 5MHz QPSK 26715 25RB#0

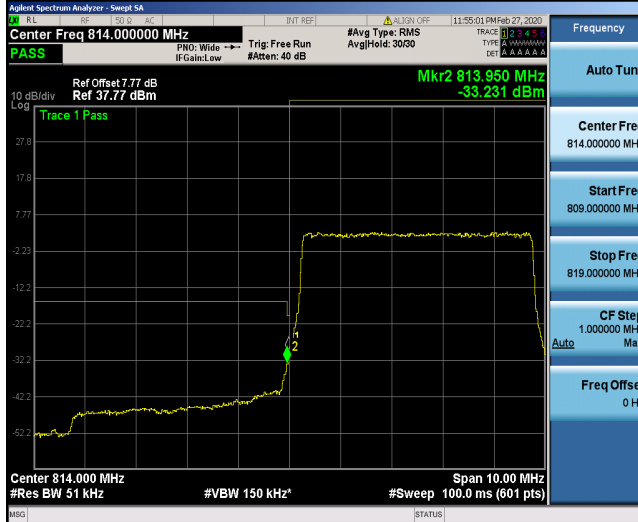

Band26 5MHz QPSK 26765 1RB#24

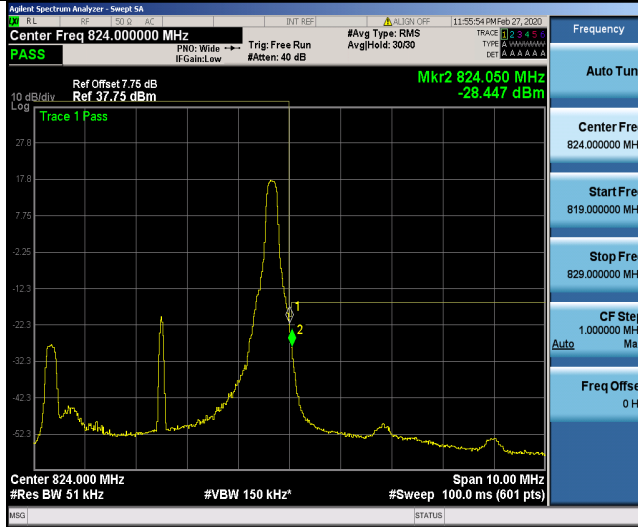

Band26 5MHz QPSK 26765 25RB#0



Band26 5MHz 16QAM 26715 1RB#0

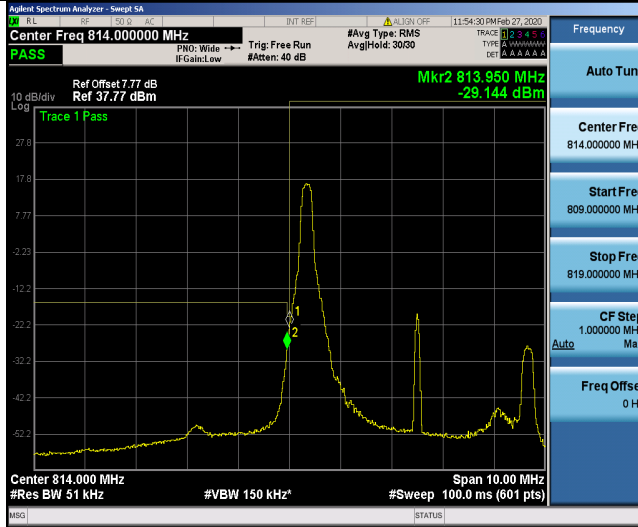

Band26 5MHz 16QAM 26715 25RB#0

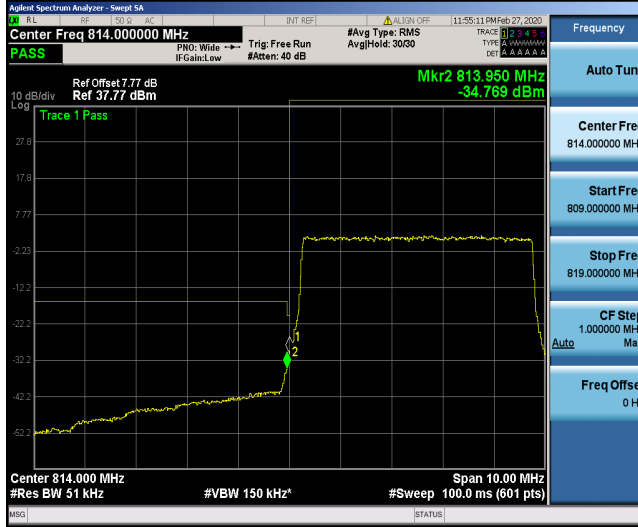

Band26 5MHz 16QAM 26765 1RB#24

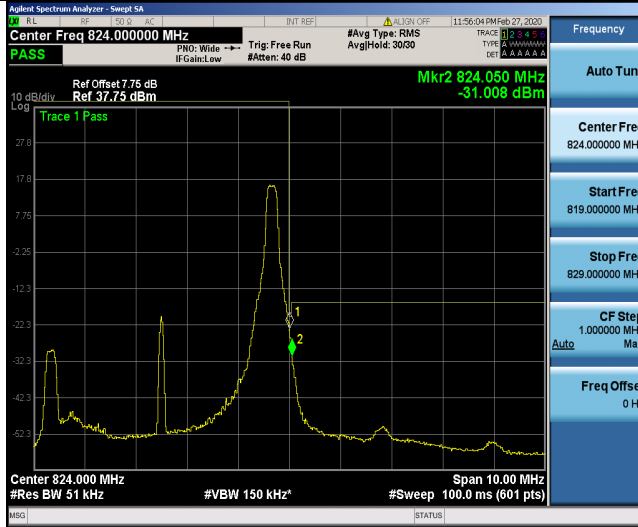

Band26 5MHz 16QAM 26765 25RB#0

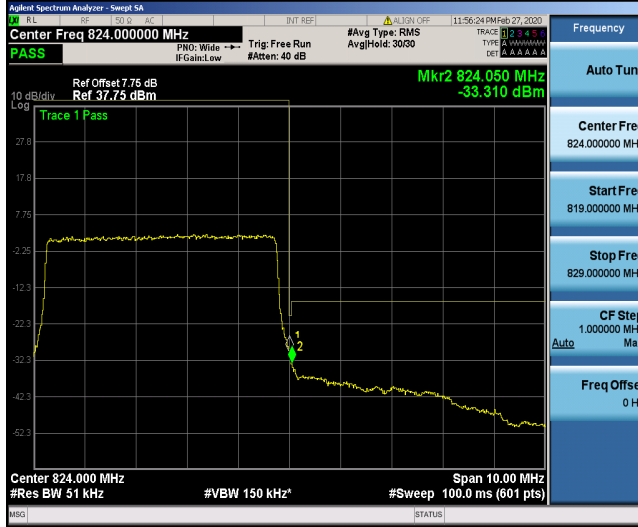

Band26 10MHz QPSK 26740 1RB#0

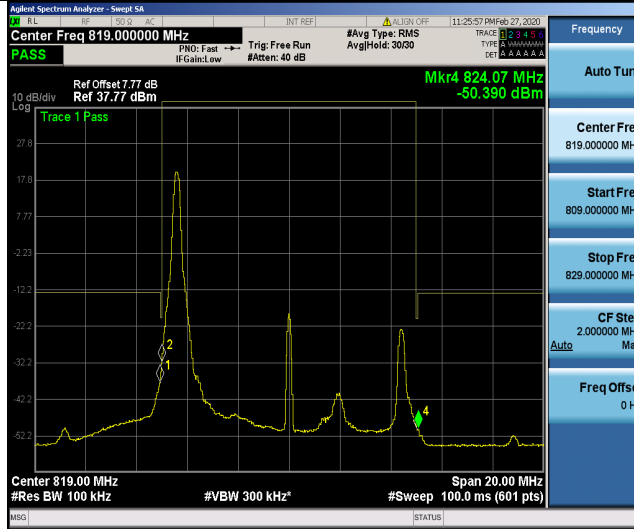

Band26 10MHz QPSK 26740 1RB#49

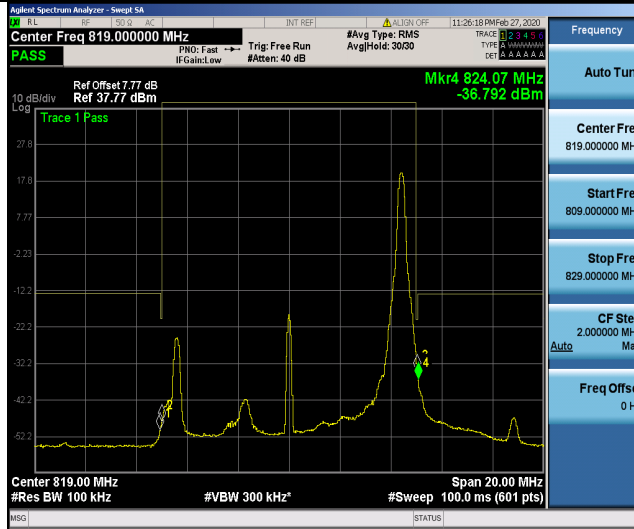

Band26 10MHz QPSK 26740 50RB#0

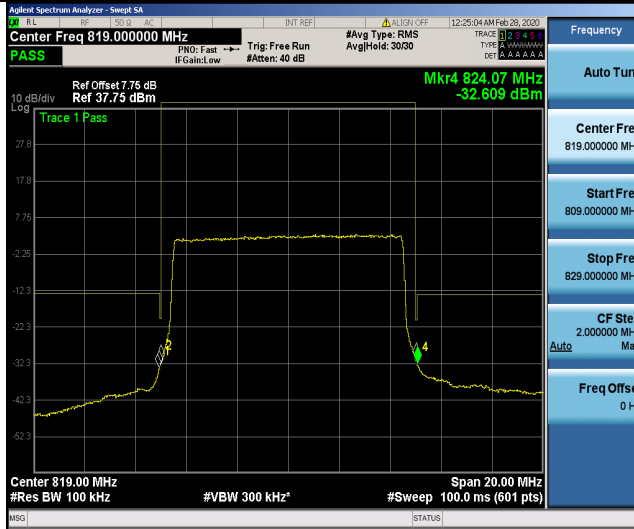

Band26 10MHz 16QAM 26740 1RB#0

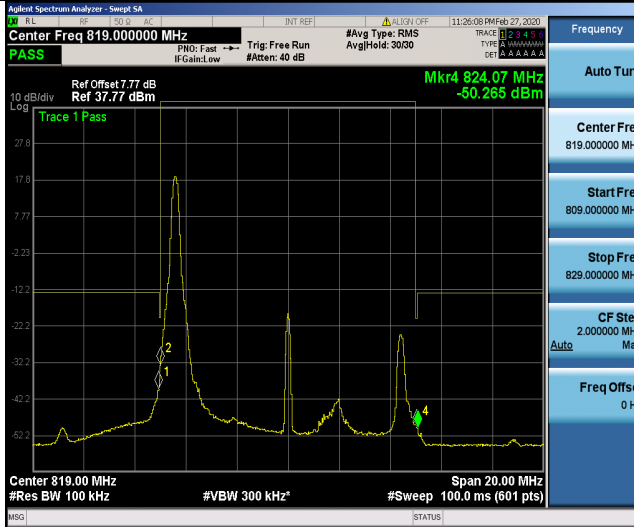

Band26 10MHz 16QAM 26740 1RB#49

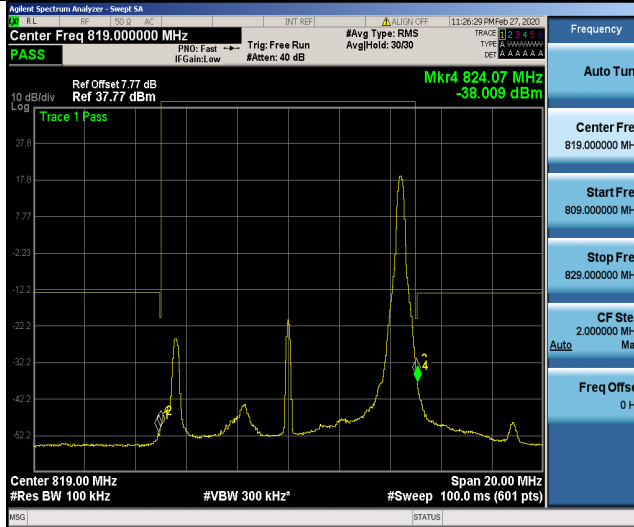

Band26 10MHz 16QAM 26740 50RB#0

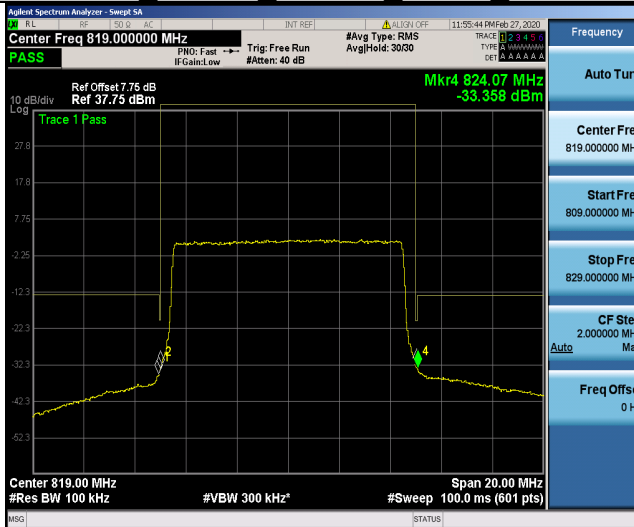

5.5. Spurious Emissions Radiated

5.5.1. Test Standard

FCC: CFR Part 2.1051, CFR Part 90.691

5.5.2. Test Limit

The radio frequency voltage or power generated within the equipment and appearing on a spurious frequency shall be checked at the equipment output terminals when properly loaded with a suitable artificial antenna. Curves or equivalent data shall show the magnitude of each harmonic and other spurious emission that can be detected when the equipment is operated under the conditions specified in FCC 2.1049 as appropriate. The magnitude of spurious emissions which are attenuated more than 20 dB below the permissible value need not be specified.

(a) Out of band emissions. The power of any emission outside of the authorized operating frequency ranges must be attenuated below the transmitting power (P) by a factor of at least $43 + 10 \log(P)$ dB. For all power levels +30dBm to 0dBm, this becomes a constant specification of -13dBm.

FCC 90.691

(a) Out-of-band emission requirement shall apply only to the "outer" channels included in an EA license and to spectrum adjacent to interior channels used by incumbent licensees. The emission limits are as follows:

(1) For any frequency removed from the EA licensee's frequency block by up to and including 37.5 kHz, the power of any emission shall be attenuated below the transmitter power (P) in watts by at least $116 \log_{10}(f/6.1)$ decibels or $50 + 10 \log_{10}(P)$ decibels or 80 decibels, whichever is the lesser attenuation, where f is the frequency removed from the center of the outer channel in the block in kilohertz and where f is greater than 12.5 kHz.

(2) For any frequency removed from the EA licensee's frequency block greater than 37.5 kHz, the power of any emission shall be attenuated below the transmitter power (P) in watts by at least $43 + 10 \log_{10}(P)$ decibels or 80 decibels, whichever is the lesser attenuation, where f is the frequency removed from the center of the outer channel in the block in kilohertz and where f is greater than 37.5 kHz.

The power of any emission shall be attenuated below the mean output power P (dBW) by at least $43 + 10 \log_{10}(p)$, measured in a 100 kHz bandwidth for frequencies less than or equal to 1 GHz, and in a 1 MHz bandwidth for frequencies greater than 1 GHz.

5.5.3. Test Procedure

1. Connect the equipment as shown in the above diagram with the EUT's antenna in a horizontal orientation.
2. Adjust the settings of the Wideband Radio Communication Tester (CMW500) to set the EUT to its maximum power at the required channel.
3. Set the spectrum analyzer to measure peak hold with the required settings.
4. Place the measurement antenna in a horizontal orientation. Rotate the EUT 360 .

Raise the measurement antenna up to 4 meters in 0.5 meters increments and rotate the EUT 360 at each height to maximize all emissions. Measure and record all

spurious emissions (LVL) up to the tenth harmonic of the carrier frequency.

5. Replace the EUT with a horizontally polarized half wave dipole or known gain antenna. The center of the antenna should be at the same location as the center of the EUT's antenna.

6. Connect the antenna to a signal generator with known output power and record the path loss in dB (LOSS). $LOSS = \text{Generator Output Power (dBm)} - \text{Analyzer reading (dBm)}$.

7. Determine the level of spurious emissions using the following equation:

$\text{Spurious (dBm)} = \text{LVL (dBm)} + \text{LOSS (dB)}$:

8. Repeat steps 4, 5 and 6 with all antennas vertically polarized.

9. Determine the level of spurious emissions using the following equation:

$\text{Spurious (dBm)} = \text{LVL (dBm)} + \text{LOSS (dB)}$:

10. Measurements are to be performed with the EUT set to the low, middle and high channel of each frequency band.

(Note: Steps 5 and 6 above are performed prior to testing and LOSS is recorded by test software. Steps 3, 4 and 7 above are performed with test software.)

Spectrum analyzer settings: RBW=VBW=1MHz

5.5.4. Test Setup

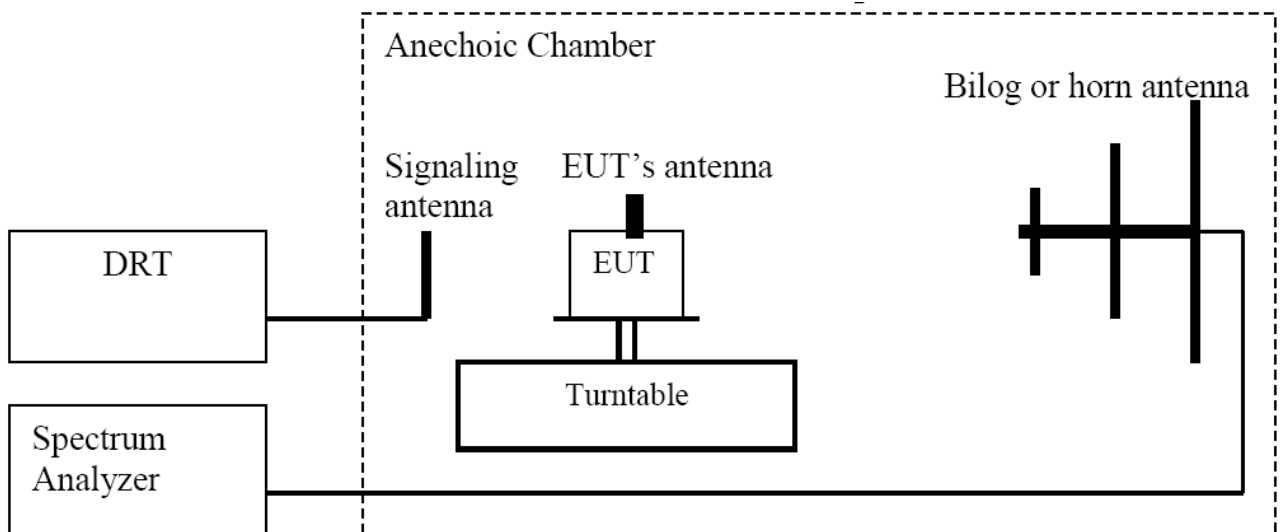

5.5.5. Test Data

Test Band = LTE Band 26

Test Mode = QPSK /TM1

Bandwidth=1.4MHz

Test Channel = MCH

Freq.	SG. Level	Cable Loss	Antenna Gain	Preamp	Substitution	Polarization	Limit
[MHz]	[dBm]	[dB]	[dBi]	dB	Level (EIRP) [dBm]		[dBm]
1638.5	-13.59	0.9	6.49	40.6	-48.6	Horizontal	-13
3276.8	-13.61	4.1	9.41	39	-47.3	Horizontal	-13
1638.5	-13.79	0.9	6.49	40.6	-48.8	Vertical	-13
3276.8	-16.41	4.1	9.41	39	-50.1	Vertical	-13

Test Band = LTE Band 26

Test Mode = 16QAM /TM2

Bandwidth=1.4MHz

Test Channel = MCH

Freq.	SG. Level	Cable Loss	Antenna Gain	Preamp	Substitution	Polarization	Limit
[MHz]	[dBm]	[dB]	[dBi]	dB	Level (EIRP) [dBm]		[dBm]
1638.5	-12.39	0.9	6.49	40.6	-47.4	Horizontal	-13
3276.8	-12.61	4.1	9.41	39	-46.3	Horizontal	-13
1638.5	-13.09	0.9	6.49	40.6	-48.1	Vertical	-13
3276.8	-16.21	4.1	9.41	39	-49.9	Vertical	-13

Test Band = LTE Band 26

Test Mode = QPSK /TM1

Bandwidth=3MHz

Test Channel = MCH

Freq.	SG. Level	Cable Loss	Antenna Gain	Preamp	Substitution	Polarization	Limit
[MHz]	[dBm]	[dB]	[dBi]	dB	Level (EIRP) [dBm]		[dBm]
1639.7	-12.09	0.9	6.49	40.6	-47.1	Horizontal	-13
3270.4	-13.91	4.1	9.41	39	-47.6	Horizontal	-13
1639.7	-12.69	0.9	6.49	40.6	-47.7	Vertical	-13
3270.4	-15.21	4.1	9.41	39	-48.9	Vertical	-13

Test Band = LTE Band 26
 Test Mode = 16QAM /TM2
 Bandwidth=3MHz
 Test Channel = MCH

Freq.	SG. Level	Cable Loss	Antenna Gain	Preamp	Substitution	Polarization	Limit
[MHz]	[dBm]	[dB]	[dBi]	dB	Level (EIRP) [dBm]		[dBm]
1639.7	-12.89	0.9	6.49	40.6	-47.9	Horizontal	-13
3270.4	-15.61	4.1	9.41	39	-49.3	Horizontal	-13
1639.7	-13.09	0.9	6.49	40.6	-48.1	Vertical	-13
3270.4	-17.41	4.1	9.41	39	-51.1	Vertical	-13

Test Band = LTE Band 26
 Test Mode = QPSK /TM1
 Bandwidth=5MHz
 Test Channel = MCH

Freq.	SG. Level	Cable Loss	Antenna Gain	Preamp	Substitution	Polarization	Limit
[MHz]	[dBm]	[dB]	[dBi]	dB	Level (EIRP) [dBm]		[dBm]
1638.6	-12.59	0.9	6.49	40.6	-47.6	Horizontal	-13
3267.2	-14.41	4.1	9.41	39	-48.1	Horizontal	-13
1638.6	-13.79	0.9	6.49	40.6	-48.8	Vertical	-13
3267.2	-19.01	4.1	9.41	39	-52.7	Vertical	-13

Test Band = LTE Band 26
 Test Mode = 16QAM /TM2
 Bandwidth=5MHz
 Test Channel = MCH

Freq.	SG. Level	Cable Loss	Antenna Gain	Preamp	Substitution	Polarization	Limit
[MHz]	[dBm]	[dB]	[dBi]	dB	Level (EIRP) [dBm]		[dBm]
1638.6	-12.99	0.9	6.49	40.6	-48.0	Horizontal	-13
3267.2	-14.01	4.1	9.41	39	-47.7	Horizontal	-13
1638.6	-13.19	0.9	6.49	40.6	-48.2	Vertical	-13
3267.2	-16.91	4.1	9.41	39	-50.6	Vertical	-13

Test Band = LTE Band 26
 Test Mode = QPSK /TM1
 Bandwidth=10MHz
 Test Channel = MCH

Freq.	SG. Level	Cable Loss	Antenna Gain	Preamp	Substitution	Polarization	Limit
[MHz]	[dBm]	[dB]	[dBi]	dB	Level (EIRP) [dBm]		[dBm]
1639.5	-11.29	0.9	6.49	40.6	-46.7	Horizontal	-13
3262.4	-14.71	4.1	9.41	39	-48.2	Horizontal	-13
1639.5	-13.89	0.9	6.49	40.6	-48.9	Vertical	-13
3262.4	-16.81	4.1	9.41	39	-50.5	Vertical	-13

Test Band = LTE Band 26
 Test Mode = 16QAM /TM2
 Bandwidth=10MHz
 Test Channel = MCH

Freq.	SG. Level	Cable Loss	Antenna Gain	Preamp	Substitution	Polarization	Limit
[MHz]	[dBm]	[dB]	[dBi]	dB	Level (EIRP) [dBm]		[dBm]
1639.5	-13.49	0.9	6.49	40.6	-48.5	Horizontal	-13
3262.4	-14.11	4.1	9.41	39	-47.8	Horizontal	-13
1639.5	-14.69	0.9	6.49	40.6	-49.7	Vertical	-13
3262.4	-16.71	4.1	9.41	39	-50.4	Vertical	-13

5.6. Frequency Stability

5.6.1. Test Standard

FCC:CFR part 2.1055, CFR Part 90.213

5.6.2. Test Limit

FCC 90.213, The carrier frequency shall not depart from the reference frequency in excess of ± 2.5 ppm for mobile stations.

5.6.3. Test Procedure

1. The transmitter output (antenna port) was connected to the BS Simulator.
2. The BS simulator was used to set the TX channel and power level and modulate the TX signal with different bit patterns.
3. BS simulator used the frequency error function and measured the peak frequency error. Power must be removed when changing from one temperature to another or one voltage to another voltage. Power warm up is at least 15 min and power applied should perform before recording frequency error. The each temperature step shall be at least 0.5 hours, consider the EUT could be test under the stability condition.
4. EUT is connected the external power supply to control the DC input power. The various Volts from the minimum 3.3 Volts to 4.2 Volts. Each step shall be record the frequency error rate.
5. The test extreme voltage is to change the primary supply voltage from 85 to 115 percent of the nominal value.
6. Extreme temperature rule is $-30^{\circ}\text{C}\sim 50^{\circ}\text{C}$.

5.6.4. Test Setup

Connect the EUT to the Wideband Radio Communication Tester (CMW500) via the connector. Then measure the frequency error by the Wideband Radio Communication Tester (CMW500). The EUT's output is matched with a $50\ \Omega$ load.

5.6.5. Test Data

Measurement Results vs. Variation of Voltage—LTE Band 26(1.4MHZ)

Modulation	Nominal Frequency (MHz)	Voltage [Vdc]	Measured Frequency Error(Hz)	Verdict
QPSK	819	3.3	-4.26	PASS
		3.8	-5.19	PASS
		4.2	-3.96	PASS
16QAM	819	3.3	-4.19	PASS
		3.8	-3.62	PASS
		4.2	-3.12	PASS

Measurement Results vs. Variation of Temperature—LTE Band 26(1.4MHZ)

Modulation	Nominal Frequency (MHz)	Temperature	Measured Frequency Error(Hz)	Verdict
QPSK	819	-30 °C	3.60	PASS
		-20 °C	-2.49	PASS
		-10 °C	2.89	PASS
		0 °C	2.92	PASS
		+10 °C	2.32	PASS
		+20 °C	-3.69	PASS
		+30 °C	-2.99	PASS
		+40 °C	-5.91	PASS
		+50 °C	-4.09	PASS
16QAM	819	-30 °C	-3.36	PASS
		-20 °C	-4.32	PASS
		-10 °C	-3.20	PASS
		0 °C	-4.76	PASS
		+10 °C	-3.46	PASS
		+20 °C	-3.91	PASS
		+30 °C	-3.93	PASS
		+40 °C	2.90	PASS
		+50 °C	2.07	PASS

Measurement Results vs. Variation of Voltage—LTE Band 26(3MHZ)

Modulation	Nominal Frequency (MHz)	Voltage [Vdc]	Measured Frequency Error(Hz)	Verdict
QPSK	819	3.3	-4.49	PASS
		3.8	-4.78	PASS
		4.2	-4.85	PASS
16QAM	819	3.3	-3.88	PASS
		3.8	-2.98	PASS
		4.2	-3.58	PASS

Measurement Results vs. Variation of Temperature—LTE Band 26(3MHZ)

Modulation	Nominal Frequency (MHz)	Temperature	Measured Frequency Error(Hz)	Verdict
QPSK	819	-30 °C	2.98	PASS
		-20 °C	2.55	PASS
		-10 °C	-3.68	PASS
		0 °C	-3.72	PASS
		+10 °C	-3.83	PASS
		+20 °C	-4.78	PASS
		+30 °C	-4.68	PASS
		+40 °C	3.25	PASS
		+50 °C	-3.33	PASS
16QAM	819	-30 °C	-2.86	PASS
		-20 °C	2.75	PASS
		-10 °C	-4.68	PASS
		0 °C	-3.99	PASS
		+10 °C	-3.49	PASS
		+20 °C	-4.01	PASS
		+30 °C	-4.92	PASS
		+40 °C	-4.59	PASS
		+50 °C	-6.75	PASS

Measurement Results vs. Variation of Voltage—LTE Band 26(5MHZ)

Modulation	Nominal Frequency (MHz)	Voltage [Vdc]	Measured Frequency Error(Hz)	Verdict
QPSK	819	3.3	-3.85	PASS
		3.8	-4.52	PASS
		4.2	-4.01	PASS
16QAM	819	3.3	-4.33	PASS
		3.8	-3.53	PASS
		4.2	-3.92	PASS

Measurement Results vs. Variation of Temperature—LTE Band 26(5MHZ)

Modulation	Nominal Frequency (MHz)	Temperature	Measured Frequency Error(Hz)	Verdict
QPSK	819	-30 °C	-5.82	PASS
		-20 °C	-4.99	PASS
		-10 °C	-5.94	PASS
		0 °C	-3.98	PASS
		+10 °C	-3.53	PASS
		+20 °C	-3.72	PASS
		+30 °C	-5.01	PASS
		+40 °C	-3.19	PASS
		+50 °C	-3.26	PASS
16QAM	819	-30 °C	-3.25	PASS
		-20 °C	-3.60	PASS
		-10 °C	-4.51	PASS
		0 °C	-4.01	PASS
		+10 °C	-3.29	PASS
		+20 °C	-4.75	PASS
		+30 °C	-4.19	PASS
		+40 °C	-3.98	PASS
+50 °C	-3.79	PASS		

Measurement Results vs. Variation of Voltage—LTE Band 26(10MHZ)

Modulation	Nominal Frequency (MHz)	Voltage [Vdc]	Measured Frequency Error(Hz)	Verdict
QPSK	819	3.3	-4.91	PASS
		3.8	-5.32	PASS
		4.2	-5.16	PASS
16QAM	819	3.3	-4.78	PASS
		3.8	-4.52	PASS
		4.2	-4.58	PASS

Measurement Results vs. Variation of Temperature—LTE Band 26(10MHZ)

Modulation	Nominal Frequency (MHz)	Temperature	Measured Frequency Error(Hz)	Verdict
QPSK	819	-30 °C	-3.96	PASS
		-20 °C	3.68	PASS
		-10 °C	-3.08	PASS
		0 °C	-3.30	PASS
		+10 °C	3.46	PASS
		+20 °C	3.45	PASS
		+30 °C	-4.03	PASS
		+40 °C	3.59	PASS
		+50 °C	-3.50	PASS
16QAM	819	-30 °C	3.50	PASS
		-20 °C	-3.71	PASS
		-10 °C	-4.86	PASS
		0 °C	-4.89	PASS
		+10 °C	-4.84	PASS
		+20 °C	-4.56	PASS
		+30 °C	-3.71	PASS
		+40 °C	-3.35	PASS
		+50 °C	-2.90	PASS

END OF REPORT