



GTX Series
UWB
(ultra wideband)
L.A.W.N.tm
Local Area Wireless
mic Network

- 1. REGULATORY AND COMPLIANCE STATEMENTS4**

- 2. OVERVIEW**
 - 2.1 System Components
 - 2.2 System Block Diagram
 - 2.3 Core Performance Targets
 - 2.4 Specifications

- 3. GTX24 UWB BODY PACK TRANSMITTER**
- 4. GTX24HH UWB HAND HELD TRANSMITTER.....**

- 5. GTX32 UWB TRANSCEIVER MODULE**
- 6. GTX3224 MAIN CONTROL UNIT**
 - 4.1. FRONT PANEL.....
 - 4.2. REAR PANEL

- 7. GUI INTERFACE**
 - 7.1. HOME SCREEN.....
 - 7.2. TRANSMITTER DETAIL SCREEN.....
 - 7.3. MATRIX SCREEN - RECEIVER MEASUREMENT
 - 7.4. MATRIX SCREEN – TRANSMITTER MEASUREMENT.....
 - 7.5. SETUP SCREEN.....

1. REGULATORY AND COMPLIANCE

This device complies with part 15 of the FCC Rules. Operation is subject to the condition that this device does not cause harmful interference.

Operation is subject to the following conditions: 1) This device may not cause harmful interference and 2) This device must accept any interference received, including interference which may cause undesired operation. Changes or modification not expressly approved by Alteros could void your authority to operate this equipment.

This device complies with Industry Canada license-exempt RSS standard(s). Operation is subject to the following two conditions: (1) this device may not cause interference, and (2) this device must accept any interference, including interference that may cause undesired operation of the device.

Le présent appareil est conforme aux CNR d'Industrie Canada applicables aux appareils radio exempts de licence. L'exploitation est autorisée aux deux conditions suivantes : (1) l'appareil ne doit pas produire de brouillage, et (2) l'utilisateur de l'appareil doit accepter tout brouillage radioélectrique subi, même si le brouillage est susceptible d'en compromettre le fonctionnement.

Note: This equipment has been tested and found to comply with the limits for a Class A digital device, pursuant to Part 15 of the FCC Rules. These limits are designed to provide reasonable protection against harmful interference when the equipment is operated in a commercial environment. This equipment generates, uses and can radiate radio frequency energy and, if not installed and used in accordance with the instruction manual, may cause harmful interference to radio communications. Operation if this equipment in a residential area is unlikely to cause harmful interference. However, if the equipment does cause harmful interference, the user will be required to correct the interference at own expense.

CAUTION! Electrical shock can result from removal of the component's covers. Static Hazard: Permanent operational damage can result from removal of the component's covers. Refer servicing to qualified service personnel. No user-serviceable parts inside. Do not expose to rain or moisture without taking appropriate precautionary steps.

The circuits inside the system components have been precisely adjusted for optimum performance and compliance with federal regulations. Do not attempt to open components. To do so will void the warranty and may cause improper operation.

Notice to individuals with implanted cardiac pacemakers or AICD devices: Any source of RF (radio frequency) energy may interfere with normal functioning of the implanted device. All wireless microphones have low-power transmitters (less than 0.05 watts output) which are unlikely to cause difficulty, especially if they are at least a few inches away. **Please contact your physician or medical-device provider if you have any questions, or experience any problems with the use of this or any other RF equipment.**

Please note that your Alteros system operates in a frequency band in a way which may make its use subject to certain FCC regulatory agency restrictions. No changes or modifications may be made to this equipment except by the expressly approved responsible party for compliance. Changes or modifications could void the user's authority to operate the equipment, and will also void Alteros warranty coverage. For further information, please contact your local office of the FCC as applicable.

2. Overview

2.1 System Components

Model	Description
<i>GTX24-2</i>	Beltpack transmitter for use with 2-wire microphones
<i>GTX24-3</i>	Beltpack Transmitter for use with Talkback Function and 3-wire microphones
<i>GTX24HH-P</i>	Handheld transmitter with interchangeable microphone capsule
<i>GTX24HH-B</i>	Handheld transmitter with interchangeable microphone capsule, extended grip (flag area) and Talkback switch
<i>GTX32</i>	UWB Transceiver Module (24 channels receiver/control transmit and antenna)
<i>GTX3224</i>	Main Control Interface Unit (3U)
<i>GTX-FX8</i>	Fiber breakout box for 8 GTX32 transceivers
<i>GTX899 or GTX899SW</i>	Omnidirectional Condenser Microphone Omnidirectional Condenser Microphone with Inline Talkback Switch

2.2 System Block Diagram

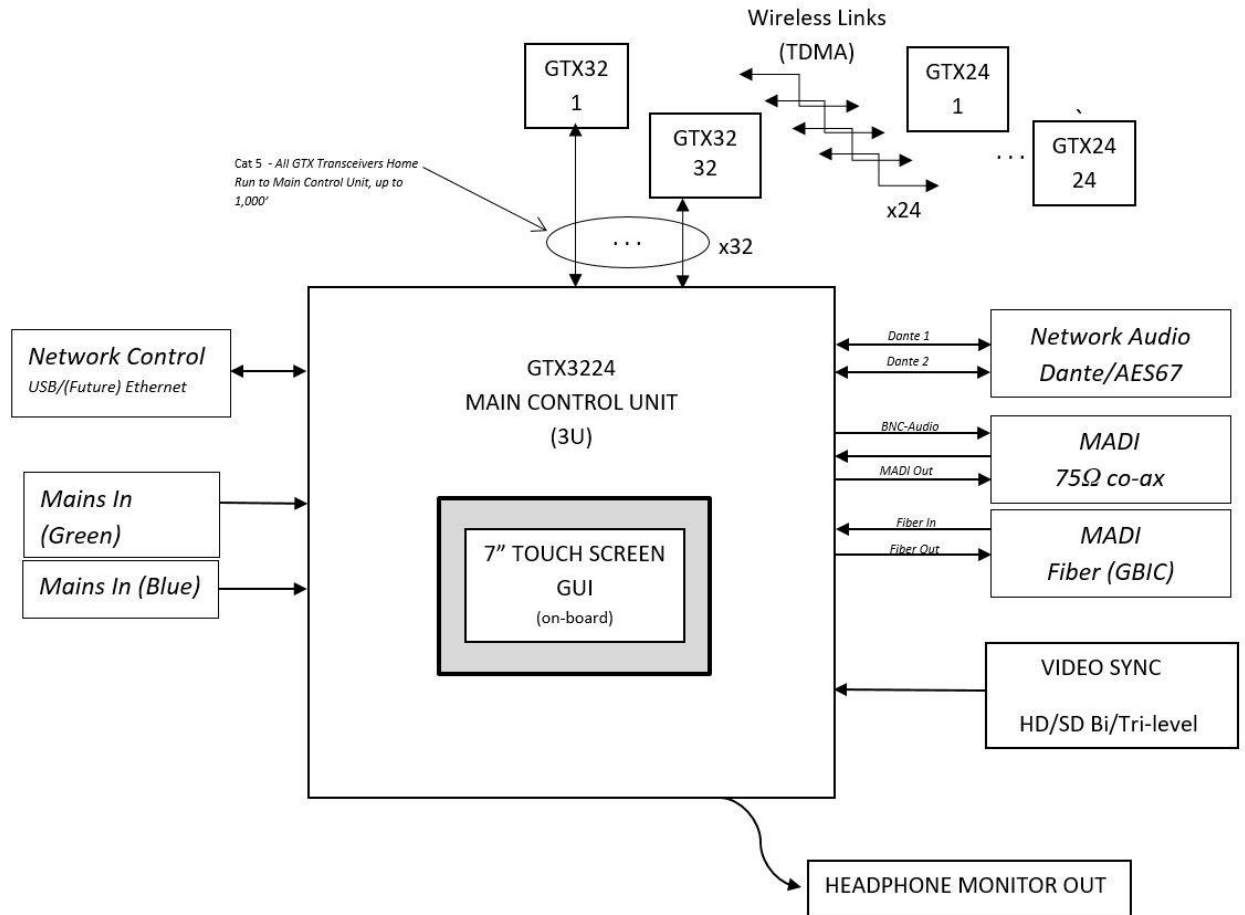

2.3 Core Performance Targets

Core Performance Targets	STUDIO BROADCAST
Operating Method	UWB OOK
Center frequency	6.500GHz
Simultaneous Transceiver Points GTX3224 (non fiber)	32
Simultaneous Transceiver Points GTX3224F (fiber module)	64
Simultaneous Transmitters	24
Audio Dynamic Range	24 bits
Frequency Response	20Hz -20kHz
Latency	<3 mS Analog to Digital out
Audio Interface	MADI/DANTE/AES67
External Control Interface	USB/Ethernet
User Interface	Touchscreen GUI
Battery Life	6 hours
Range (single GTX32 transceiver line of sight)	90 feet
Range single mode fiber (LC connector)	6,000 feet

2.4 Specifications

Overall System	
Dynamic Range	>109 dB (A-weighted, typical)
Total Harmonic Distortion	<0.06% (-40dBV input level)

GTX24 Specs (inherent transmitter)	Direct connect
Self Noise @ 0dB gain	-111dBA
Self Noise @ 20dB gain	-106dBA
Sensitivity @ 0dB gain	-44dBV
Sensitivity @ 20dB gain	-23dBV
Dynamic Range	111dB (A-weighted, typical)
SNR @ 0dB gain	67dBA
SNR @ 20 dB gain	82dBA
Maximum Input Level (5% THD)	4.8dBV
Total Harmonic Distortion	<0.06% (-40dBV input level)
Operating Frequency Range	6250MHz – 6750MHz
Tx Output Power	74nW average
Modulation	OOK (on off keying, no modulated carrier)
Emissions Designator	500MN1W

GTX24 w/ GTX899 or GTX899SW mic and GTX24HH	
Self-Noise @ 0dB gain	-109dBA
Self-Noise @ 20dB gain	-93dBA
Sensitivity @ 0dB gain	-48dBV
Sensitivity @ 20dB gain	-28dBV
Dynamic Range	109dB (A-weighted, typical)
SNR @ 0dB gain	61dBA
SNR @ 20dB gain	65dBA
Frequency Response	20Hz – 20,000Hz
Impedance	250 ohms
DC current	1.7mA
Battery	2 x AA
Battery life	6 hours

GTX3224 Main Control Unit	
Frequency Response	20Hz – 20,000Hz
Input/Output Connections	
MADI	2 x 75 ohm BNC to coax, 2 x multimode or singlemode fiber
DANTE/AES67	2 x RJ45
GTX32 transceivers	32 x 12 V, RJ45
HD/SD bi/tri-level	1 x BNC
Wordclock	1 x BNC
Headphone/Monitor Out	@ 33 ohm load
Total Harmonic Distortion	<0.1%
Noise	-90dBV
Maximum Output Power	200mW
Power	
Redundant AC supply	2 x 100-240VAC, 50-60Hz, 480W max
Cable	2 x IEC

3. GTX24 UWB Beltpack Transmitter

3.1 Batteries

The GTX24 operates via 2 x AA size batteries.

When inserting the batteries into the GTX24, observe correct polarity as marked.

Do not peel off or damage the outer tube of the battery.

Do not use a leaking battery. If battery leakage occurs, avoid contact with skin. If contact occurs, immediately wash thoroughly with soap and water. If battery leakage comes into contact with your eyes, immediately flush with water and seek medical attention.

Do not expose batteries to fire. Do not heat, deform, solder, disassemble or modify batteries.

For best operation, do not use batteries of different types together, old or new batteries together, or batteries with different charge levels.

Slide On/Off switch to "on" position

Insert 2 x AA batteries observing proper polarity



3.2 Transmitter Controls

- An On/Off power switch is located in the battery compartment.
- The adjustable transmitter parameters are shown on a display located on the face of the transmitter.
- The adjustable transmitter parameters are:

1. System ID (SYS) – Each transmitter must be assigned a system ID (1-9) that must match the system ID set on the GTX3224

Each transmitter will only transmit after it receives permission to transmit from the system. In order to receive permission, synchronization with the system must be established and the system ID from the system must match with the transmitter. This will prevent users with transmitters assigned the same channel time slot from a different system ID from interfering if they enter the coverage area of another system. If your transmitter is not linking, check that the transmitter system ID matches the system ID shown on the tools screen of the GTX3224 Main Control Unit.

Note: The system ID does not apply to GTX32 transceivers. GTX32 transceivers from separate systems must be physically/RF/temporally isolated from one another to prevent system timing collisions.

2. Channel Number (CHAN) – The channel time slot assigned to the transmitter (01-24.) Each transmitter in the system is assigned a unique channel number that represents the time it should operate in the TDMA controlled scheme. To operate the GTX24 transmitter, turn on and set each GTX24 transmitter to be used in the system to its own channel time slot. The default setting upon turn on is CHAN 1. To operate more than one transmitter with the system, you must set each GTX24 to a different channel number. No frequency coordination, registration or database checking is

required. Simply turn each transmitter to a channel time slot from 01 to 24 and operate.

Note: If two GTX24 transmitters are set to the same channel time slot and same system ID #, they will not operate properly.

3. Input level (GAIN) – Adjustment of the audio input level (0 dB to 20dB in 2dB Steps).

The display figures will only be illuminated when the user is adjusting the transmitter. Pressing any button will activate the full display for 10 seconds. After 10 seconds, display functions will no longer be illuminated although the GTX24 is functioning. A single small red indicator dot will show in the bottom right of the display to let the user know there is power. The light will be continuously on as long as there is the required round-trip operating link to the system. The light will blink if the GTX24 power is on, but there is no link to the system. If the power is not on, or the batteries are dead, there will be no small red light displayed.

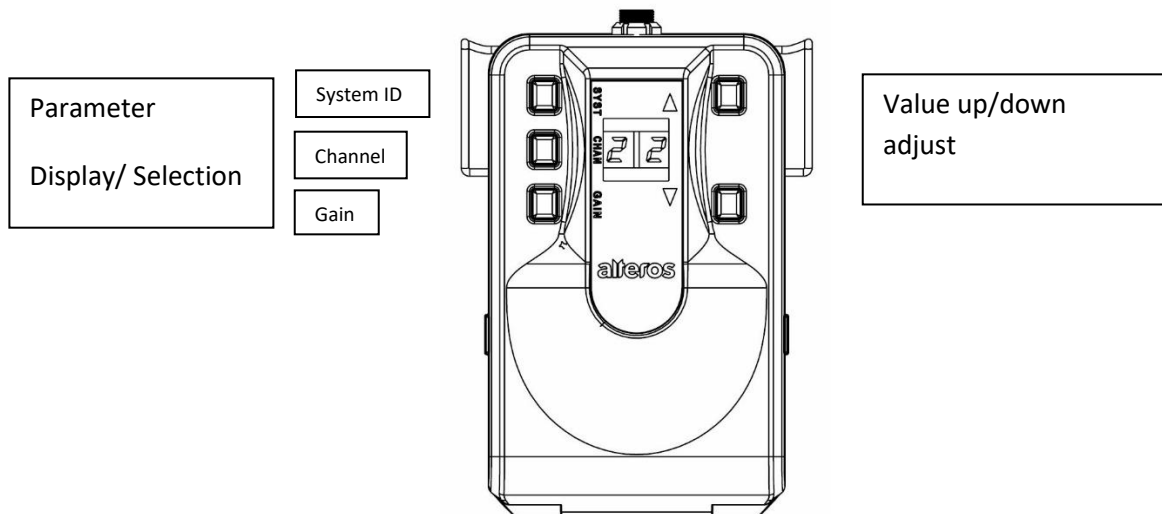

- Adjustment Process:
 1. Press and Hold (2 sec) the button associated with the parameter to be adjusted - SYST, CHAN or GAIN.
 2. The selected parameter value will flash on the screen.
 3. Make the desired adjustment via the up down arrow keys while the value is flashing.
 4. The new value will be shown, and remains flashing until confirmed.
 5. Confirm the new value by continuing to hold the parameter button from step 1 until the flashing stops.
 6. If the parameter button is not held for confirmation, the parameter will return to the original value.

Note: If there is no button pressed for a 10 second period the transmitter will revert to its original settings and the display will go dark.

3.3 Transmitter Audio Output Routing

The system includes a talkback function utilizing 58 output channels in either the MAD1 stream or DANTE/AES67 network output. In normal operation, audio will be routed to the audio channel that matches the channel time slot number assigned (Audio Channel = CHAN = 1 - 24). The talkback function is activated by connecting the appropriate transmitter connector contact to ground when the in-line talkback switch of the AT899cL4SW microphone is depressed. The talkback function is a press and hold operation. While the talkback button is depressed, the audio output will be routed to a channel in the range of 25 to 48 - equal to the channel time slot number + 24 (Audio Channel = CHAN +24) and an 8 additional talkback/cue groups that are assigned to channels 49-56 if desired (assigning cue groups is not necessary). Upon button release, the audio channel returns to the normal operation on the assigned channel 1-24.

4. GTX24HH UWB Handheld Transmitter

4.1 Batteries

The GTX24 operates via 2 x AA size batteries.

Access the battery compartment and GTX24HH controls by gently unscrewing and sliding open the lower outside microphone handle.

When inserting the batteries into the GTX24HH, observe correct polarity as marked. (Note they both orient with + “up”).

Do not peel off or damage the outer tube of the battery.

Do not use a leaking battery. If battery leakage occurs, avoid contact with skin. If contact occurs, immediately wash thoroughly with soap and water. If battery leakage comes into contact with your eyes, immediately flush with water and seek medical attention.

Do not expose batteries to fire. Do not heat, deform, solder, disassemble or modify batteries.

For best operation, do not use batteries of different types together, old or new batteries together, or batteries with different charge levels.

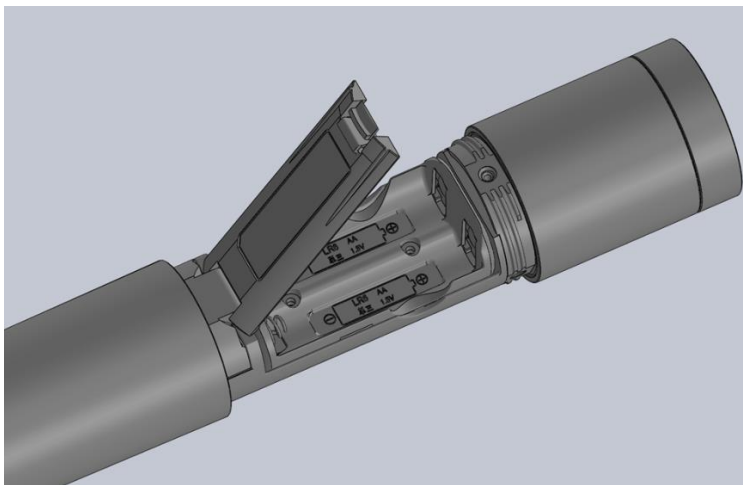

4.4 On/Off and Transmitter Controls

The On/Off power switch and Controls are inside the microphone body, opposite of the battery compartment. Access this area by gently unscrewing and sliding open the lower outside microphone handle.

The adjustable transmitter parameters are shown on a display located on inside the transmitter.

The adjustable transmitter parameters are:

1. System ID (SYS) – Each transmitter must be assigned a system ID (1-9) that must match the system ID set on the GTX3224

Each transmitter will only transmit after it receives permission to transmit from the system. In order to receive permission, synchronization with the system must be established and the system ID from the system must match with the transmitter. This will prevent users with transmitters assigned the same channel time slot from a different system ID from interfering if they enter the coverage area of another system. If your transmitter is not linking, check that the transmitter system ID matches the system ID shown on the tools screen of the GTX3224 Main Control Unit.

Note: The system ID does not apply to GTX32 transceivers. GTX32 transceivers from separate systems must be physically/RF/temporally isolated from one another to prevent system timing collisions.

2. Channel Number (CHAN) – The channel time slot assigned to the transmitter (01-24.) Each transmitter in the system is assigned a unique channel number that represents the time it should operate in the TDMA controlled scheme. To operate the GTX24 transmitter, turn on and set each GTX24HH transmitter to be used in the system to its own channel time slot. The default setting upon turn on is CHAN 1.

To operate more than one transmitter with the system, you must set each GTX24HH to a different channel number. No frequency coordination, registration or database checking is required. Simply turn each transmitter to a channel time slot from 01 to 24 and operate.

Note: If two GTX24HH transmitters are set to the same channel time slot and same system ID #, they will not operate properly.

3. Input level (GAIN) – Adjustment of the audio input level (0 dB to 20dB in 2dB Steps).

The display figures will only be illuminated when the user is adjusting the transmitter. Pressing any button will activate the full display for 10 seconds. After 10 seconds, display functions will no longer be illuminated although the GTX24HH is functioning. A single small red indicator dot will show in the bottom right of the display to let the user know there is power. The light will be continuously on as long as there is the required round-trip operating link to the system. The light will blink if the GTX24HH power is on, but there is no link to the system. If the power is not on, or the batteries are dead, there will be no small red light displayed.

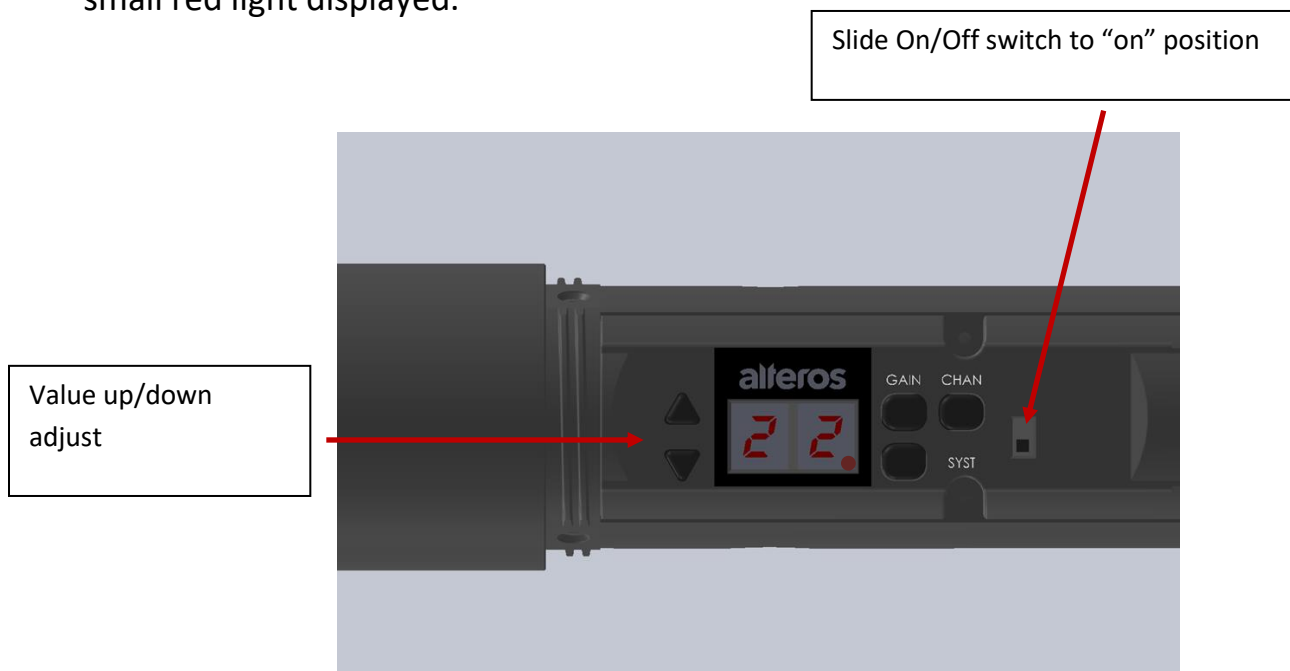

- Adjustment Process:
 7. Press and Hold (2 sec) the button associated with the parameter to be adjusted - SYST, CHAN or GAIN.
 8. The selected parameter value will flash on the screen.
 9. Make the desired adjustment via the up down arrow keys while the value is flashing.
 10. The new value will be shown, and remains flashing until confirmed.
 11. Confirm the new value by continuing to hold the parameter button from step 1 until the flashing stops.
 12. If the parameter button is not held for confirmation, the parameter will return to the original value.

Note: If there is no button pressed for a 10 second period the transmitter will revert to its original settings and the display will go dark.

5. GTX32 UWB Transceiver Module

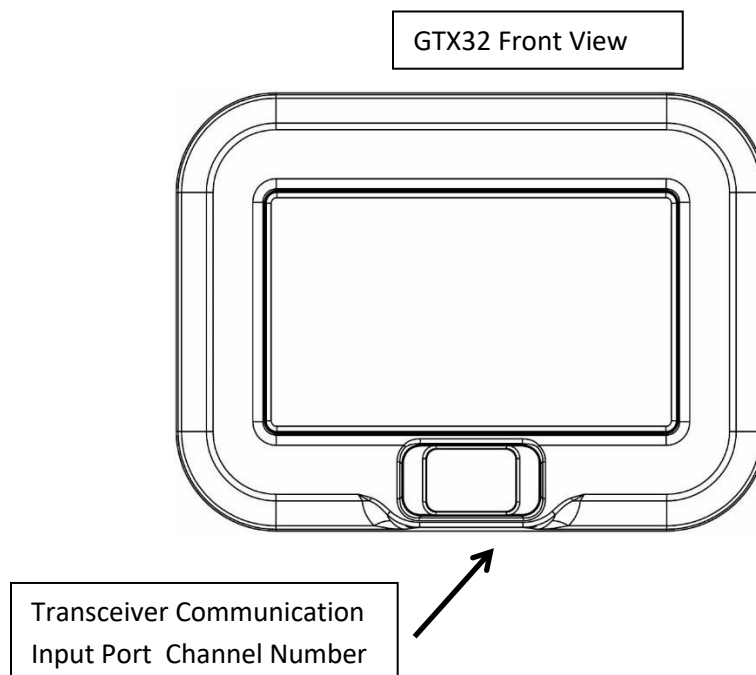

The GTX wireless microphone system operates in a space which is defined by the placement of GTX32 transceiver modules.

Operating somewhat like micro-cell devices, each GTX32 transceiver unit houses both transmit and receive antennas. It sends control, system and sync coordination information to all GTX transmitters within its range. Via the TDMA scheme, it also receives all 24 possible channels of audio data from 24 possible simultaneous transmitters and processes the signals for return to the GTX3224 MCU. Once at the MCU, several layers of error correction and signal quality decision are processed. While only a single GTX32 transceiver is needed for the system to operate, utilizing multiple transceivers provides for fully redundant receivers, and a diversity signal processing method equal to the number of GTX32 transceivers in use in each system. A space should be covered by GTX32 transceivers much in the same way as one would set up lights to fill a space. When multiple GTX32 units are set-up, they create a “coverage mesh” in which the system will operate. GTX32 transceivers send “permission to transmit” signals to GTX transmitters when a full round-trip link can be maintained with appropriate BER performance. Thus, if a GTX transmitter moves out of the coverage space, transmission will cease. Transmission will begin within 1 second when the GTX transmitter returns to a location within the GTX32 mesh coverage area. This operation is seamless and totally noise-free. There is no signal quality degradation or other negative artifact associated with the permission to transmit scheme.

Set-up Note: GTX32 transceivers work best when mounted high and above the area of desired coverage, with a more or less clear line-of-sight. *It is very much like setting up lights to illuminate an area.*

A full line-of-sight is not entirely necessary, but it is generally preferred. GTX32 transceivers can also be mounted behind light set pieces, walls, or furniture if necessary; as long as the obstacle is not metal or metallic. Coverage range is reduced when working through a set-wall or furniture, and this needs to be kept in mind during placement. The transmit and pick-up pattern of the GTX32 antennas is similar to a directional shotgun with a 90’ front lobe and 70 degree acceptance angle. The widest operational coverage can be found at approximately 40’.

The pattern becomes very narrow when in close proximity, and side-lobes are present when operating within 16 feet of the device. There is also a small rear-lobe. The signals that are transmitted and received in this system are very effectively bounced and utilized via multi-path. A general antenna pattern estimate drawing is shown below, but due to very positive influence of multi-path signals, this drawing does not fully represent the operation once in a physical space.

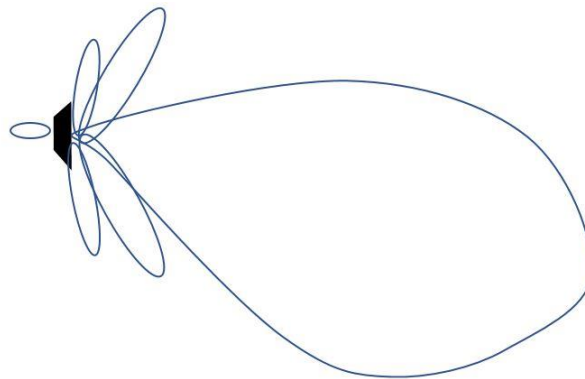

(not to scale)

Note: Although a single GTX32 transceiver may pick up all 24 channels of operation, Alteros recommends that the system be set up with a coverage area that will provide for at least three GTX32 transceivers in link with each GTX24 transmitter at all times from any location/orientation. Additional covering GTX32 units will then provide receiver redundancy and additional system diversity security.

Connection of the GTX32 transceiver to the system is uncomplicated. Simply attach one end of a shielded CAT-5 cable to the RJ45 jack on the back of the GTX32 and the other end to the RJ45 input jack on the rear of the GTX3224 Main Control Unit. The CAT-5 cable can be up to 1,000 feet long with no performance degradation.

Important note: The GTX wireless microphones system uses a proprietary communication protocol over the CAT-5 cable for the purposes of extended range and highly precise system synchronization. GTX32 transceivers DO NOT connect via ethernet. DO NOT plug an ethernet connection into a GTX3224 transceiver input jack. GTX32 transceivers can be operated via a home-run connection through a physical switch if this allows for easier set-up and cabling, but they will not operate through a network or ethernet switch. For more information about switching, we suggest you look into the Alteros SWX8 and SWX8C switches.

Other than connecting the GTX32 to the GTX3224, no other steps are needed. The GTX3224 MCU will discover the connected cable, send power to the GTX32 and begin communication automatically. A two digit display (7 Segment LED) is provided to automatically indicate the corresponding input port number when the GTX32 is connected via a CAT5 cable to the RJ45 jack of a corresponding channel of the GTX3224 Main Control Unit (MCU). This display serves as the unit's power indicator.

A visible channel number also indicates that there is a full round-trip connection between the GTX32 and the GTX3224 communications, confirming that the cable, the GTX32 transceiver and the corresponding MCU port are all operating appropriately. Should the user prefer that the LED lights not be illuminated, there is a control option available on the MCU "tools" screen which allows the display lights to be turned off.

Note: The input port number is completely operationally agnostic, and is used only for convenience sake for device location/identification. Each GTX32 transceiver module will transmit and receive signals from all 24 possible channels of GTX24 transmitters in operation.

Mounting the GTX32 is simple. The rear of the unit features both a 5/8" -27 threaded insert and a 1/4" -20 threaded insert for attachment to various stands or clamps. The unit weighs under 1 pound, and is easily utilized without adding undue weight on set or physical features.

A sometimes convenient location is to mount the GTX32 transceiver directly to a camera jib. This ensures coverage following talent.

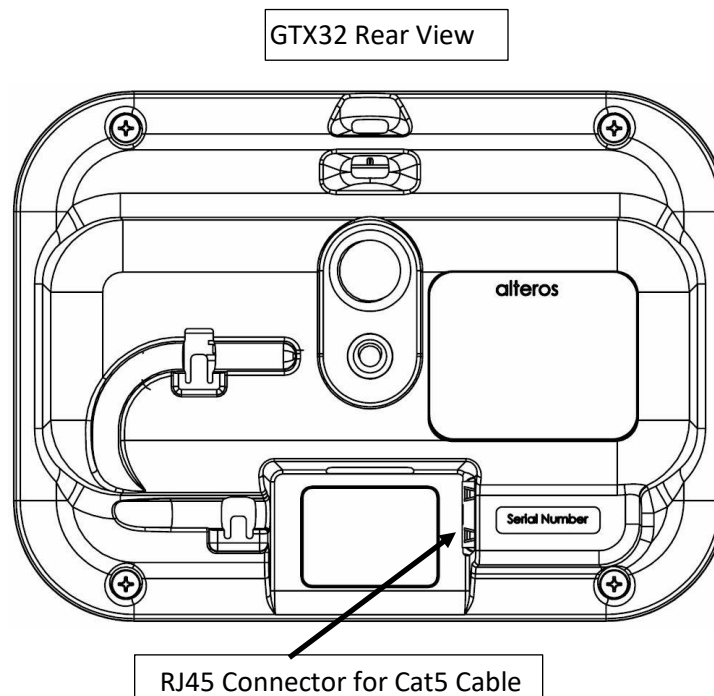

6. GTX3224 Main Control Unit

The main control unit (sometimes referred to as the MCU) is the central connection and control point for the system. It also supplies the power required to operate up to 32 GTX32 transceivers via standard shielded CAT 5 cable. This unit provides operational coordination, regulates system timing and feeds the audio output to the end user's system as desired. The MCU allows user control/adjustment of operating preferences and management of both transmitters and receivers.

The audio outputs - MADI, Networked Audio Protocol are all contained within this 3U sized unit, with appropriate output connections on the rear. A touchscreen GUI, and internal headphone monitor output/meter are provided for user control and monitoring.

The GTX3224 operates via 2 fully redundant 110-220V 50-60Hz AC power supplies via 2 separate standard IEC power cables. The unit is fully operational with a single power cable and power supply. A front panel display will indicate a blue light for the 1st power supply and a green light for the 2nd power supply.

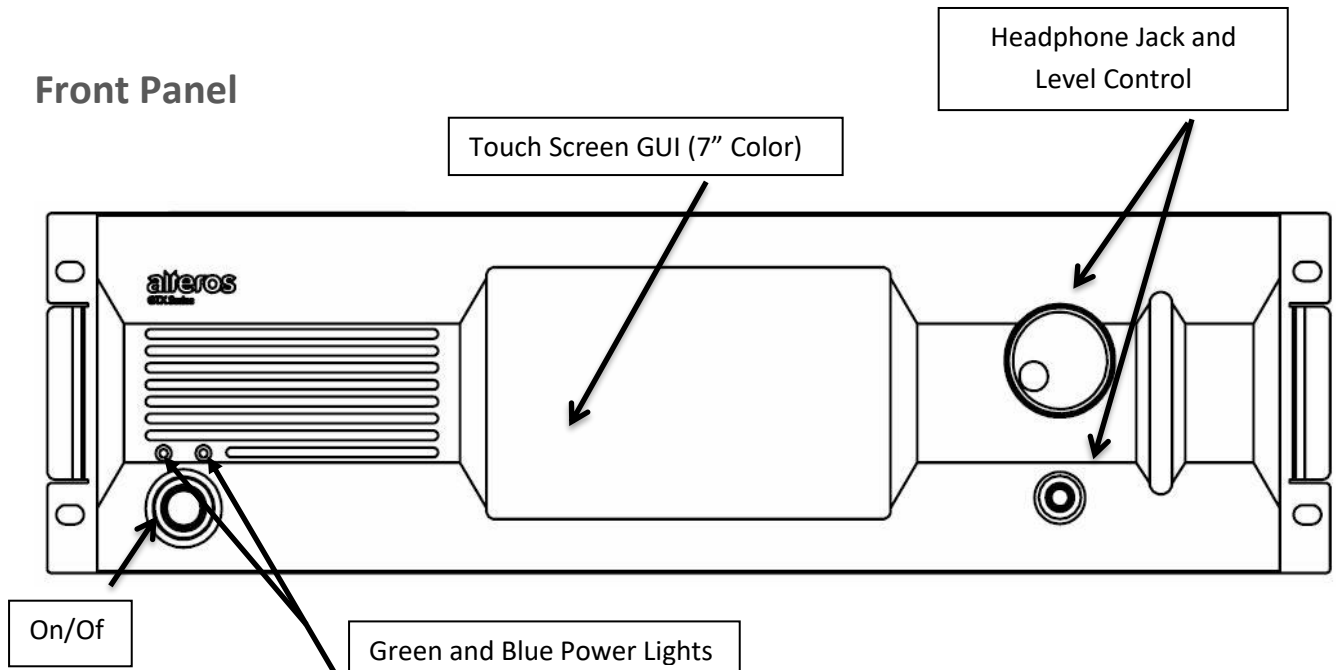



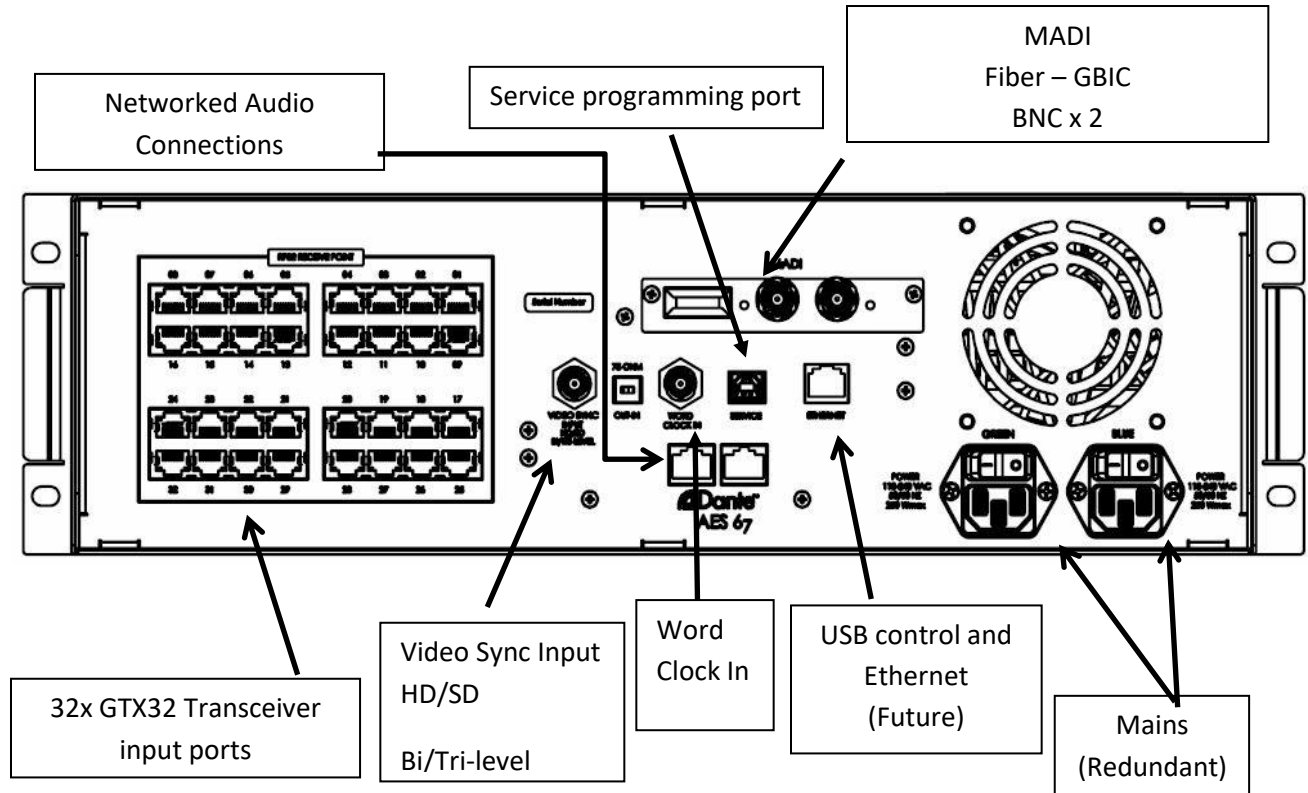

The Front Panel design has minimal controls; the majority of Monitoring and control are handled through the touchscreen GUI. If a channel is selected using the GUI its audio will be routed to the headphone jack and VU meter.

Rear Panel

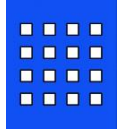

7. GTX3224 Main Control Unit GUI Interface

The GUI interface is divided into four screens:

	<p>Home Screen – This screen will display an overview of all 24 transmit channel slots at once. The user will be able to select the “active” channel on this screen by tapping the corresponding channel tile. The audio from the active channel will be sent to the headphone monitor output.</p>
	<p>Transmitter Detail Screen – Activating this screen will display more detailed information about the status of the active channel, including battery information, gain setting and connection history.</p>
	<p>Matrix Screen – This screen is used for system set up, coverage confirmation and detailed debugging of receivers and transmitter links.</p>
	<p>System Setup – This screen contains the basic system set up parameters. Dante and MADI set up information, Ethernet IP Address, System ID, battery warning level, turning off GTX32 transceiver displays, and even a method to activate a steady 1KHz test tone which transmits from the GTX24 transmitter in order for walk-out testing/coverage testing.</p> <p>The number in the center indicates the System ID.</p>

a. Home Screen

The home screen displays all 24 possible channel time slots. If a transmitter is turned on and linked for a given channel time slot, a green BER bar will be displayed corresponding to this channel.

A black (or red for warning level) bar will be displayed on the right side of the green BER bar to indicate battery level.

Three circles above the green BER bar indicate the link condition of at least the desired three simultaneous (diversity) reception from GTX32 transceivers. As the GTX32 transceivers established link with the GTX24 transmitter, the circle will become green in color.

Note: Additional GTX32 transceivers may be in used and/or linked to the GTX24 transmitter, but the home screen displays data for only 3 as this is the minimum recommended quantity.

To proceed to detailed information regarding a channel time slot or specific GTX24 transmitter operation, or to send the audio of a specific GTX24 transmitter to the headphone monitor output, press the screen at the corresponding channel. The channel display will highlight yellow, confirming the channel is selected.

b. Transmitter Detail Screen

The detail screen gives the user a view of the selected channel's transmitter information in one place; including a history of the transmitter's link status, and battery use details.

A history of link information is displayed over a user-selectable time scale from two to sixty minutes (additional time – up to 31 days of time-stamped logging is available via the separate companion computer logging software). Each bar indicates the minimum number of transceivers the transmitter is linked to for up to five GTX32 transceivers. If the link is dropped, a red mark shows the time when it happened.



The user will be able to control the transmitter audio input level from this screen.

The user may press either the up or down arrow to select the desired gain setting.

This action will cause the new value to be displayed (in red) and a “Set” button will appear. The setting is not changed on the transmitter until the set button is pressed.

Activating another function on the GUI or allowing a 10 second interval without interaction will abandon the change.

Once the set button is pressed, the system will send a command to the transmitter to change the setting. When the transmitter acknowledges the change, the set button will disappear, and the setting color will change back to white.

Note: When the transmitter is not in link this option will not be available.

Any change made at the GTX24 transmitter to gain setting will also automatically be recorded and shown on this screen.

A battery life gauge is available on the transmitter detail screen. The gauge shows actual minutes left for operation.

c. Matrix Screen - GTX32 transceiver Measurement

The matrix screen allows the user to visualize specific connections between 32 possible transceivers and 24 possible transmitters. There are two modes: Receiver Link and Transmitter Link.

In the receiver test mode the user selects a source GTX24 transmitter – (example below: the transmitter on channel time slot 14) via the blue buttons on the right side of the screen. The screen on the left indicates all GTX32 transceivers that are connected to the system (blue outline). Any GTX32 transceiver that is actively linked with the selected GTX24 transmitter will display a green “linked” color.

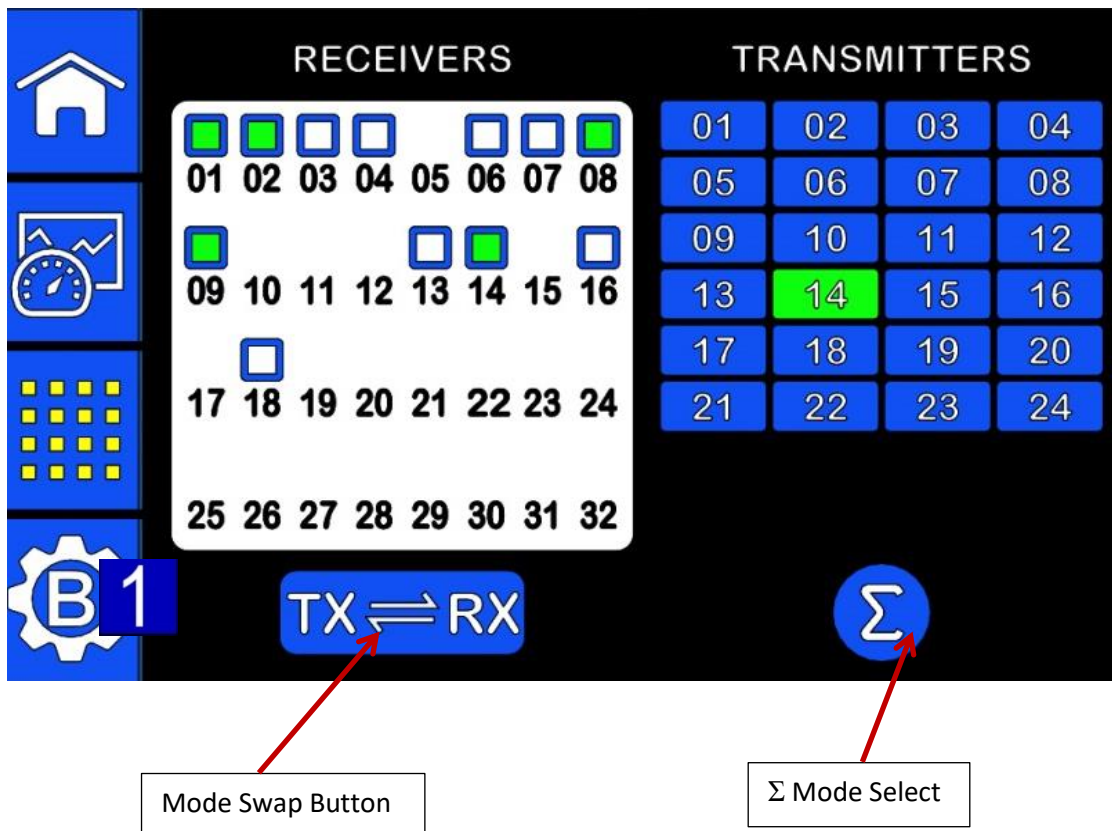

The Σ button is used to view all GTX32 transceivers that are connected to ANY active transmitter rather than just a single transmitter. This mode is used to test which transceivers receivers are most effective in a given set up, and may assist in placement.

When the user selects the matrix screen, the system will first check for added GTX32 transceivers; without interrupting the operation of the active receivers or the audio output. This gives the user a way to add transceivers while the system is in active operation.

Pressing the mode swap button switches to Transmitter measurement mode. See next section.

d. Matrix Screen – Transmitter Measurement

In this mode, the user selects a specific GTX32 transceiver via the right-hand side “receivers” blue buttons, and the display will show every GTX24 transmitter that is linked to that transceiver.

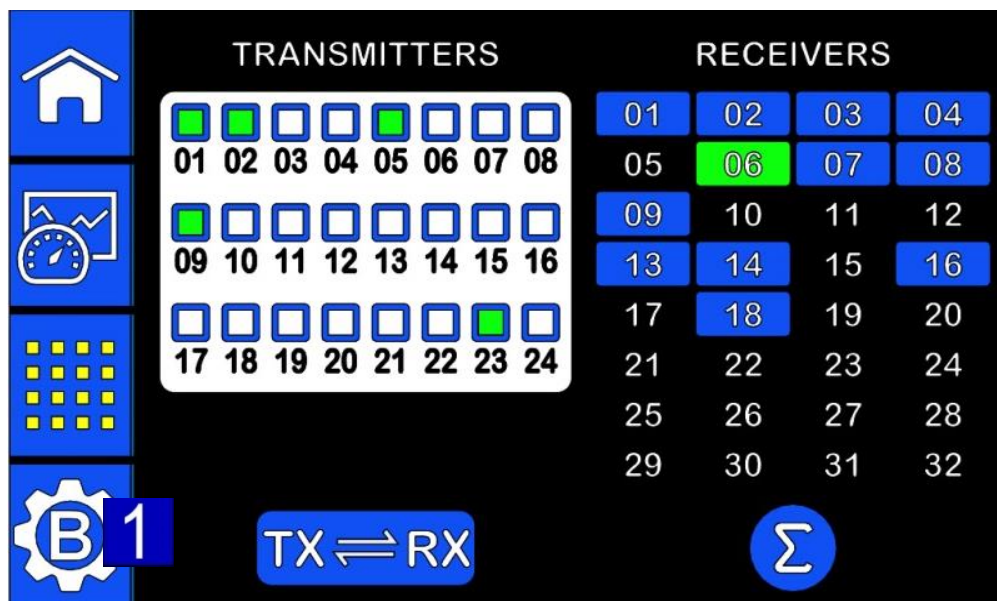

Σ -mode operation is similar - when selected, the system will show transmitters that are connected to any GTX32 transceiver in the system. This is a quick way to make sure that all transmitters are connected to the system by at least one receiver.

e. Setup Screen – User “TOOLS”

The setup screen allows the user to monitor certain key system performance values or settings, and allows system parameters and operation values which may be determined by user preferences. Monitor and control includes:

7. IP Address for the network adaptor
8. DHCP
9. Dante/Clock Sync precision
10. System ID (1-9)
11. Reference Clock Source –Black Burst, Word clock, Dante
12. RP display (on/off) control
13. Battery fuel gauge time to empty warning “alert” setting preference
14. Test Mode – activates a test tone through the system so that the user can carry out a constant-signal walkout test while setting up and de-bugging the system. **NOTE: No normal audio operation is available when in the test tone mode, and the mode must be exited in order for the system to operate normally.**

To enter and activate any of the TOOLS screen functions, press on the screen graphic for the desired parameter. The display for the selected parameter will blink. Press the “SET” button on the number pad to confirm the change.

To enter TEST MODE, press on the screen graphic at the “OFF” position under test mode. The parameter will begin to blink. Enter the #s 3224 on the keypad and then press “SET.” The display for TEST MODE will now change to a green color and display “ACTIVE.” To immediately stop the TEST TONE, press on the screen where it says “OFF.”

For further information regarding the set-up or operation of the Alteros GTX UWB Wireless Microphone System, please see our website: www.Alteros.tech or contact us at (330) 686-8120

