



Certification Test Report

FCC ID: 2AJX7KP9000D
IC: 21998-KP9000D

FCC Rule Part: 15.247
ISED Canada Radio Standards Specification: RSS-247

Report Number: 16-0272.W06.1A

Manufacturer: QSR Automations, Inc.
Model: KP-9000D

Test Begin Date: June 28, 2016
Test End Date: July 8, 2016

Report Issue Date: August 14, 2018



FOR THE SCOPE OF ACCREDITATION UNDER Certificate Number: AT-2021

This report must not be used by the client to claim product certification, approval, or endorsement by ANAB, NIST, or any agency of the Federal Government.

Prepared by:

Ryan McGann
Wireless Program Manager
TUV SUD America

Reviewed by:

Thierry Jean-Charles
EMC Engineer
TUV SUD America

This test report shall not be reproduced except in full. This report may be reproduced in part with prior written consent of TUV SUD America. The results contained in this report are representative of the sample(s) submitted for evaluation.

This report contains 20 pages

TABLE OF CONTENTS

1	GENERAL	3
1.1	PURPOSE	3
1.2	PRODUCT DESCRIPTION	3
1.3	TEST METHODOLOGY AND CONSIDERATIONS	3
2	TEST FACILITIES	4
2.1	LOCATION	4
2.2	LABORATORY ACCREDITATIONS/RECOGNITIONS/CERTIFICATIONS	4
2.3	RADIATED EMISSIONS TEST SITE DESCRIPTION	5
2.3.1	<i>Semi-Anechoic Chamber Test Site</i>	5
2.3.2	<i>Open Area Tests Site (OATS)</i>	6
2.4	CONDUCTED EMISSIONS TEST SITE DESCRIPTION	7
3	APPLICABLE STANDARD REFERENCES	7
4	LIST OF TEST EQUIPMENT	8
5	SUPPORT EQUIPMENT	9
6	EQUIPMENT UNDER TEST SETUP BLOCK DIAGRAM	9
7	SUMMARY OF TESTS	10
7.1	ANTENNA REQUIREMENT – FCC 15.203	10
7.2	POWER LINE CONDUCTED EMISSIONS – FCC 15.207, ISED CANADA: RSS-GEN 8.8	10
7.2.1	<i>Measurement Procedure</i>	10
7.2.2	<i>Measurement Results</i>	10
7.3	6dB / 99% BANDWIDTH – FCC 15.247(A)(2), ISED CANADA: RSS-247 5.2(1)	12
7.3.1	<i>Measurement Procedure</i>	12
7.3.2	<i>Measurement Results</i>	12
7.4	FUNDAMENTAL EMISSION OUTPUT POWER – FCC 15.247(B)(3), ISED CANADA: RSS-247 5.4(4)	14
7.4.1	<i>Measurement Procedure</i>	14
7.4.2	<i>Measurement Results</i>	14
7.5	EMISSION LEVELS	15
7.5.1	<i>Emissions into Non-restricted Frequency Bands – FCC 15.247(d); ISED Canada: RSS-247 5.5</i>	15
7.5.1.1	<i>Measurement Procedure</i>	15
7.5.1.2	<i>Measurement Results</i>	15
7.5.2	<i>Emissions into Restricted Frequency Bands – FCC: 15.205, 15.209; ISED Canada: RSS-GEN 8.9/8.10</i>	17
7.5.2.1	<i>Measurement Procedure</i>	17
7.5.2.2	<i>Measurement Results</i>	17
7.5.2.3	<i>Sample Calculation:</i>	18
7.6	MAXIMUM POWER SPECTRAL DENSITY IN THE FUNDAMENTAL EMISSION – FCC 15.247(E) ISED CANADA: RSS-247 5.2(2)	19
7.6.1	<i>Measurement Procedure</i>	19
7.6.2	<i>Measurement Results</i>	19
8	CONCLUSION	20

1 GENERAL

1.1 Purpose

The purpose of this report is to demonstrate compliance with Part 15 Subpart C of the FCC's Code of Federal Regulations and Innovation, Science, and Economic Development Canada's Radio Standards Specification RSS-247 Certification.

1.2 Product Description

The KP-9000D is a USB to Bluetooth Low Energy gateway allowing Bluetooth Low Energy devices to connect to a USB Host.

Technical Information:

Detail	Description
Frequency Range	2402 – 2480 MHz
Number of Channels	40
Modulation Format	GFSK
Operating Voltage	5 Vdc (USB)
Antenna Type / Gain	Printed Meandering Trace Antenna / -7dBi gain

Manufacturer Information:

QSR Automations, Inc.
2301 Stanley Gault Pkwy
Louisville, KY 40223

EUT Serial Numbers: ACS #1 (Radiated Emissions / Power line Conducted Emissions)
ACS #3 (RF Conducted)

Test Sample Condition: The test samples were provided in good working order with no visible defects.

1.3 Test Methodology and Considerations

All modes of operation, including all available data rates, were evaluated. The data presented in this report represents the worst case where applicable.

For Radiated Emissions, the EUT was programmed to generate a continuously modulated signal on each channel investigated. The EUT was evaluated in three orthogonal orientations. The worst case orientation was Z-orientation. See test setup photos for more information.

For RF Conducted Emissions, the EUT was programmed to generate a continuously modulated signal on each channel investigated. The EUT was modified with an SMA connector to facilitate connection to the test equipment.

Power setting during test: +4 dBm

2 TEST FACILITIES

2.1 Location

The radiated and conducted emissions test sites are located at the following address:

TUV SUD America
5015 B.U. Bowman Drive
Buford, GA 30518
Phone: (770) 831-8048
Fax: (770) 831-8598

2.2 Laboratory Accreditations/Recognitions/Certifications

TUV SUD America is accredited to ISO/IEC 17025 by the ANSI-ASQ National Accreditation Board/ANAB accreditation program, and has been issued certificate number AT-2021 in recognition of this accreditation. Unless otherwise specified, all tests methods described within this report are covered under the ISO/IEC 17025 scope of accreditation.

The Semi-Anechoic Chamber Test Site, Open Area Test Site (OATS) and Conducted Emissions Site have been fully described, submitted to, and accepted by the FCC, ISED Canada and the Japanese Voluntary Control Council for Interference by information technology equipment.

FCC Registration Number: 391271

ISED Canada Lab Code: IC 23932

VCCI Member Number: 1831

- VCCI OATS Registration Number R-1526
- VCCI Conducted Emissions Site Registration Number: C-1608

2.3 Radiated Emissions Test Site Description

2.3.1 Semi-Anechoic Chamber Test Site

The Semi-Anechoic Chamber Test Site consists of a 20' x 30' x 18' shielded enclosure. The chamber is lined with Toyo Ferrite Grid Absorber, model number FFG-1000. The ferrite tile grid is 101 x 101 x 19mm thick and weighs approximately 550 grams. These tiles are mounted on steel panels and installed directly on the inner walls of the chamber.

The turntable is 150cm in diameter and is located 160cm from the back wall of the chamber. The chamber is grounded via 1 - 8' copper ground rod, installed at the center of the back wall, it is bound to the ground plane using 3/4" stainless steel braided cable.

The turntable is all steel, flush mounted table installed in an all steel frame. The table is remotely operated from inside the control room located 25' from the range. The turntable is electrically bonded to the surrounding ground plane via steel fingers installed on the edge of the turn table. The steel fingers make constant contact with the ground plane during operation.

Behind the turntable is a 3' x 6' x 4' deep shielded pit used for support equipment if necessary. The pit is equipped with 1 - 4" PVC chases from the turntable to the pit that allow for cabling to the EUT if necessary. The underside of the turntable can be accessed from the pit so cables can be supplied to the EUT from the pit.

A diagram of the Semi-Anechoic Chamber Test Site is shown in Figure 2.3-1 below:

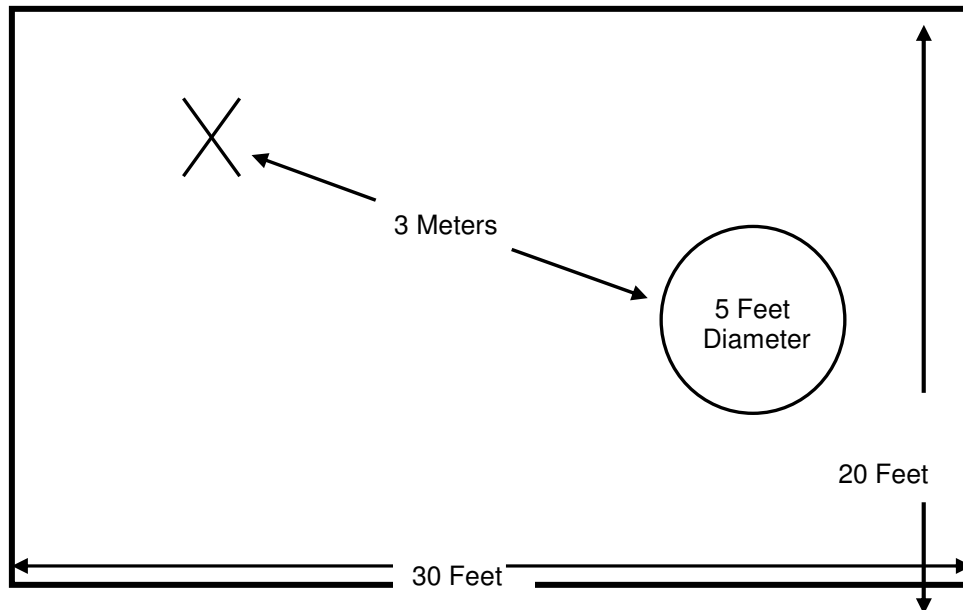

Figure 2.3-1: Semi-Anechoic Chamber Test Site

2.3.2 Open Area Tests Site (OATS)

The open area test site consists of a 40' x 66' concrete pad covered with a perforated electro-plated galvanized sheet metal. The perforations in the sheet metal are 1/8" holes that are staggered every 3/16". The individual sheets are placed to overlap each other by 1/4" and are riveted together to provide a continuous seam. Rivets are spaced every 3" in a 3 x 20 meter perimeter around the antenna mast and EUT area. Rivets in the remaining area are spaced as necessary to properly secure the ground plane and maintain the electrical continuity.

The entire ground plane extends 12' beyond the turntable edge and 16' beyond the antenna mast when set to a 10 meter measurement distance. The ground plane is grounded via 4 - 8' copper ground rods, each installed at a corner of the ground plane and bound to the ground plane using 3/4" stainless steel braided cable.

The turntable is an all aluminum 10' flush mounted table installed in an all aluminum frame. The table is remotely operated from inside the control room located 40' from the range. The turntable is electrically bonded to the surrounding ground plane via steel fingers installed on the edge of the turn table. The steel fingers make constant contact with the ground plane during operation.

Adjacent to the turntable is a 7' x 7' square and 4' deep concrete pit used for support equipment if necessary. The pit is equipped with 5 - 4" PVC chases from the pit to the control room that allow for cabling to the EUT if necessary. The underside of the turntable can be accessed from the pit so cables can be supplied to the EUT from the pit. The pit is covered with 2 sheets of 1/4" diamond style re-enforced steel sheets. The sheets are painted to match the perforated steel ground plane; however the underside edges have been masked off to maintain the electrical continuity of the ground plane. All reflecting objects are located outside of the ellipse defined in ANSI C63.4.

A diagram of the Open Area Test Site is shown in Figure 2.3-2 below:

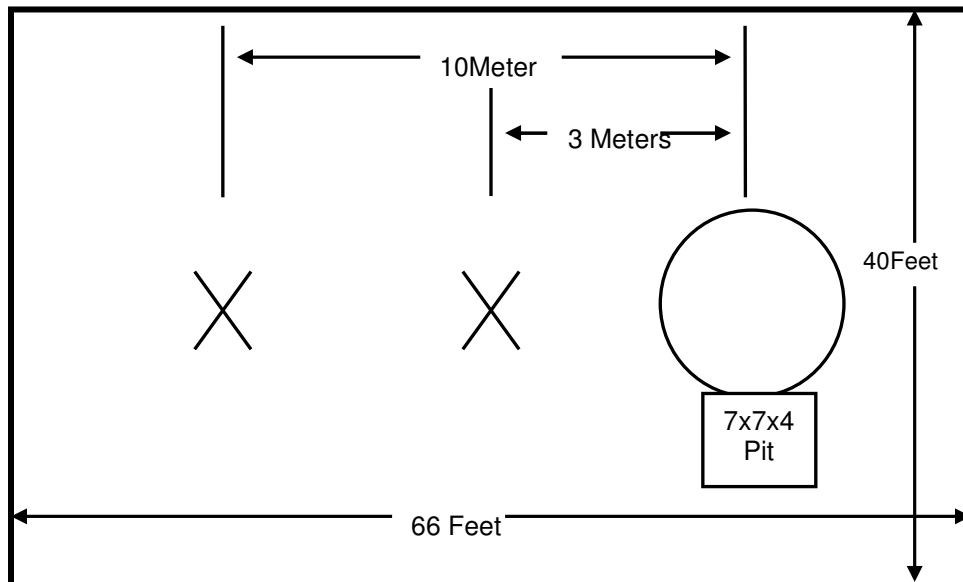

Figure 2.3-2: Open Area Test Site

2.4 Conducted Emissions Test Site Description

The AC mains conducted EMI site is located in the main EMC lab. It consists of an 8' x 8' solid aluminum horizontal ground reference plane (GRP) bonded every 3" to an 8' X 8' vertical ground plane.

The site is of sufficient size to test table top and floor standing equipment in accordance with section 6.1.4 of ANSI C63.4.

A diagram of the room is shown below in figure 4.1.3-1:

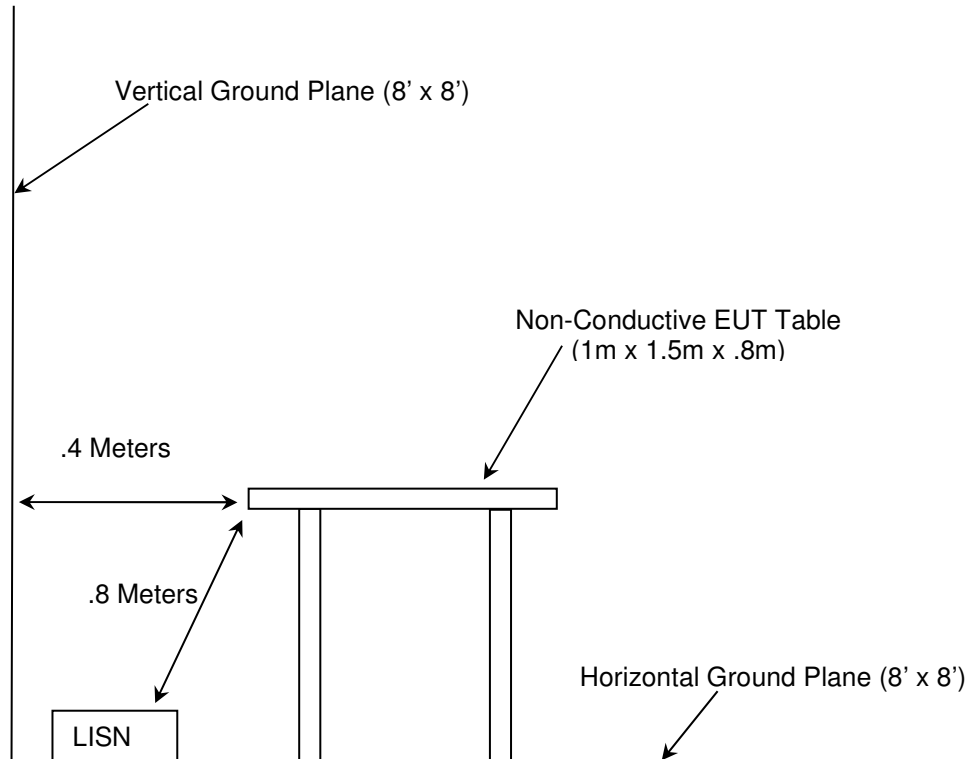

Figure 2.4-1: AC Mains Conducted EMI Site

3 APPLICABLE STANDARD REFERENCES

The following standards were used:

- ❖ ANSI C63.4-2014: American National Standard for Methods of Measurement of Radio-Noise Emissions from Low-Voltage Electrical and Electronic Equipment in the Range of 9kHz to 40GHz
- ❖ ANSI C63.10-2013: American National Standard of Procedures for Compliance Testing of Unlicensed Wireless Devices
- ❖ US Code of Federal Regulations (CFR): Title 47, Part 2, Subpart J: Equipment Authorization Procedures, 2016
- ❖ US Code of Federal Regulations (CFR): Title 47, Part 15, Subpart C: Radio Frequency Devices, Intentional Radiators, 2016
- ❖ FCC KDB 558074 D01 DTS Meas Guidance v03r05 - Guidance for Performing Compliance Measurements on Digital Transmission Systems (DTS) Operating Under §15.247, April 8, 2016.
- ❖ ISED Canada Radio Standards Specification: RSS-247 – Digital Transmission Systems (DTSs), Frequency Hopping Systems (FHSs) and Licence-Exempt Local Area Network (LE-LAN) Devices, Issue 1, May 2015
- ❖ ISED Canada Radio Standards Specification: RSS-GEN – General Requirements for Compliance of Radio Apparatus, Issue 4, Nov 2014.

4 LIST OF TEST EQUIPMENT

The calibration interval of test equipment is annually or the manufacturer's recommendations. Where the calibration interval deviates from the annual cycle based on the instrument manufacturer's recommendations, it shall be stated below.

Table 4-1: Test Equipment

AssetID	Manufacturer	Model #	Equipment Type	Serial #	Last Calibration Date	Calibration Due Date
1	Rohde & Schwarz	ESMI - Display	Spectrum Analyzers	833771/007	7/11/2014	7/11/2016
2	Rohde & Schwarz	ESMI-Receiver	Spectrum Analyzers	839587/003	7/14/2015	7/14/2016
30	Spectrum Technologies	DRH-0118	Antennas	970102	4/30/2015	4/30/2017
40	EMCO	3104	Antennas	3211	2/10/2015	2/10/2017
73	Agilent	8447D	Amplifiers	2727A05624	7/15/2015	7/15/2016
167	ACS	Cable Set	Cable Set	167	10/20/2015	10/20/2016
267	Agilent	N1911A	Meters	MY45100129	8/24/2015	8/24/2017
268	Agilent	N1921A	Sensors	MY45240184	8/13/2015	8/13/2017
292	Florida RF Cables	SMR-290AW-480.0-SMR	Cables	N/A	2/17/2016	2/17/2017
324	ACS	Belden	Cables	8214	5/2/2016	5/2/2017
334	Rohde&Schwarz	3160-09	Antennas	49404	11/4/2010	NCR
335	Suhner Sucoflex	SF-102A	Cables	882/2A	7/14/2015	7/14/2016
338	Hewlett Packard	8449B	Amplifiers	3008A01111	8/21/2015	8/21/2017
340	Aeroflex/Weinschel	AS-20	Attenuators	7136	7/13/2015	7/13/2016
345	Suhner Sucoflex	102A	Cables	1077/2A	7/14/2015	7/14/2016
412	Electro Metrics	LPA-25	Antennas	1241	7/24/2014	7/24/2016
422	Florida RF	SMS-200AW-72.0-SMR	Cables	805	10/30/2015	10/30/2016
432	Microwave Circuits	H3G020G4	Filters	264066	5/13/2016	5/13/2017
616	Florida RF Cables	SMRE-200W-12.0-SMRE	Cables	N/A	9/3/2015	9/3/2016
622	Rohde & Schwarz	FSV40	Analyzers	101338	7/15/2015	7/15/2016
3010	Rohde & Schwarz	ENV216	LISN	3010	7/10/2015	7/10/2016
RE112	Rohde & Schwarz	ESIB26	Receiver	836119/012	7/16/2015	7/16/2016

5 SUPPORT EQUIPMENT

Table 5-1: Support Equipment

Item	Equipment Type	Manufacturer	Model Number	Serial Number
1	Laptop Computer	Dell	Latitude E7250	BBQDF72
2	Laptop Power Supply	Dell	LA65NS2-01	CN-06TM1C-72438-591-6C6E-A04

Table 5-2: Cable Description

Item	Cable Type	Length	Shield	Termination
A	USB Cable	200 cm	No	1 – EUT
B	DC Power Cable	250 cm	No	1 – 2
C	AC Power Cable	100 cm	No	2 – AC Mains

6 EQUIPMENT UNDER TEST SETUP BLOCK DIAGRAM

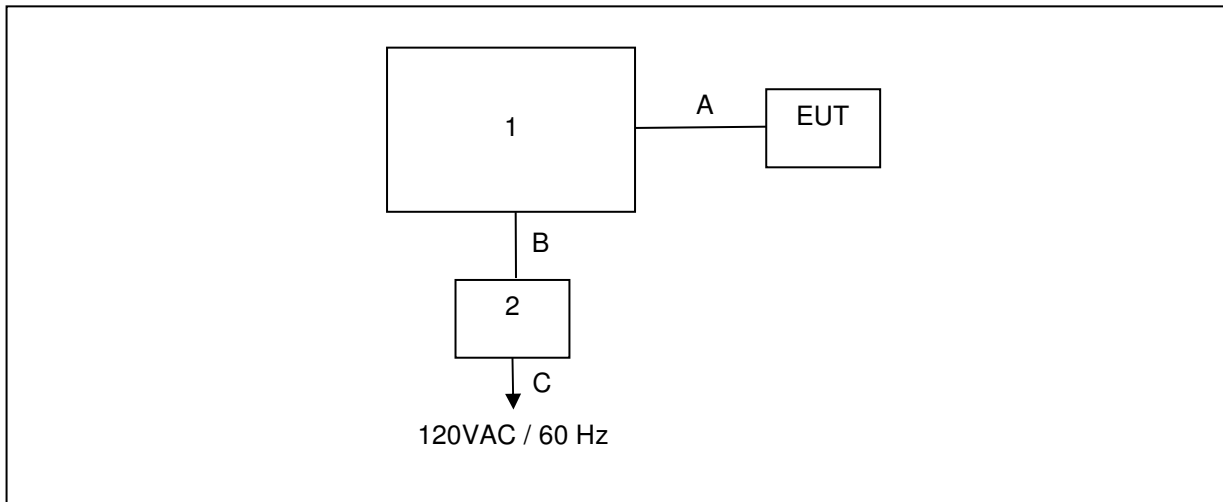

Figure 6-1: Test Setup Block Diagram

7 SUMMARY OF TESTS

Along with the tabular data shown below, plots were taken of all signals deemed important enough to document.

7.1 Antenna Requirement – FCC 15.203

The EUT utilizes a Printed Meandering Trace antenna with a gain of -7dBi. The antenna is integral to the device and cannot be removed or replaced by the end user, therefore satisfying the requirements of 15.203.

7.2 Power Line Conducted Emissions – FCC 15.207, ISED Canada: RSS-Gen 8.8

7.2.1 Measurement Procedure

ANSI C63.10 section 6 was the guiding document for this evaluation. Conducted emissions were performed from 150kHz to 30MHz with the spectrum analyzer's resolution bandwidth set to 9kHz and the video bandwidth set to 30kHz. The calculation for the conducted emissions is as follows:

Corrected Reading = Analyzer Reading + LISN Loss + Cable Loss

Margin = Applicable Limit - Corrected Reading

7.2.2 Measurement Results

Table 7.2.2-1: Conducted EMI Results Line 1

Frequency (MHz)	Corrected Reading		Limit (dBuV)	Margin (dB)	Line	Correction (dB)
	Quasi-Peak (dBuV)	Average (dBuV)				
0.558618	---	25.56	46.00	20.44	L1	9.7
0.558618	42.94	---	56.00	13.06	L1	9.7
1.871843	---	27.02	46.00	18.98	L1	9.8
1.871843	39.52	---	56.00	16.48	L1	9.8
1.976653	---	27.61	46.00	18.39	L1	9.8
1.976653	40.07	---	56.00	15.93	L1	9.8
1.984675	---	27.52	46.00	18.48	L1	9.8
1.984675	39.89	---	56.00	16.11	L1	9.8
2.000870	---	27.24	46.00	18.76	L1	9.8
2.000870	39.56	---	56.00	16.44	L1	9.8
2.235170	---	28.09	46.00	17.91	L1	9.8
2.235170	39.25	---	56.00	16.75	L1	9.8

Table 7.2.2-2: Conducted EMI Results Line 2

Frequency (MHz)	Corrected Reading		Limit (dBuV)	Margin (dB)	Line	Correction (dB)
	Quasi-Peak (dBuV)	Average (dBuV)				
0.469239	---	32.82	46.48	13.66	N	9.7
0.469239	42.77	---	56.49	13.72	N	9.7
0.483267	---	30.70	46.26	15.56	N	9.7
0.483267	41.65	---	56.26	14.61	N	9.7
1.932665	---	29.95	46.00	16.05	N	9.8
1.932665	36.94	---	56.00	19.06	N	9.8
2.110922	---	30.50	46.00	15.50	N	9.8
2.110922	37.62	---	56.00	18.38	N	9.8
2.383467	---	29.34	46.00	16.66	N	9.8
2.383467	36.27	---	56.00	19.73	N	9.8
2.403708	---	29.12	46.00	16.88	N	9.8
2.403708	36.55	---	56.00	19.45	N	9.8

7.3 6dB / 99% Bandwidth – FCC 15.247(a)(2), ISED Canada: RSS-247 5.2(1)

7.3.1 Measurement Procedure

The 6dB bandwidth was measured in accordance with the FCC KDB 558074 D01 DTS Meas Guidance. The Resolution Bandwidth (RBW) of the spectrum analyzer was set to 100 kHz. The Video Bandwidth (VBW) was set to ≥ 3 times the RBW. The trace was set to max hold with a peak detector active. The ndB down function of the spectrum analyzer was utilized to determine the 6 dB bandwidth of the emission.

The occupied bandwidth measurement function of the spectrum analyzer was used to measure the 99% bandwidth. The span of the analyzer was set to capture all products of the modulation process, including the emission sidebands. The resolution bandwidth was set to 1% to 5% of the occupied bandwidth. The video bandwidth was set to 3 times the resolution bandwidth. A peak detector was used.

7.3.2 Measurement Results

Table 7.3.2-1: 6dB / 99% Bandwidth

Frequency [MHz]	6dB Bandwidth [kHz]	99% Bandwidth [kHz]
2402	639.51	1043.87
2440	650.45	1103.56
2480	652.32	1026.22

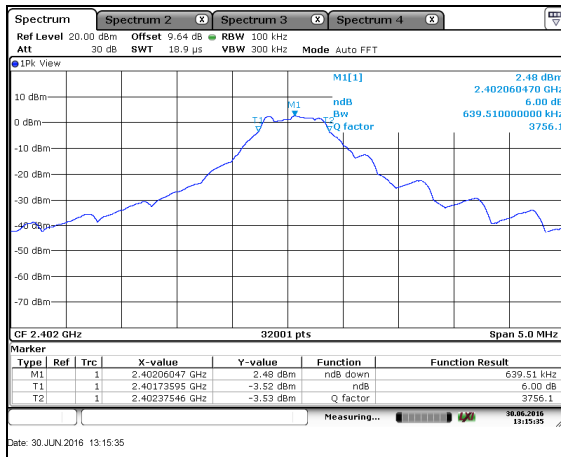

Figure 7.3.2-1: 6dB Bandwidth Plot – LCH

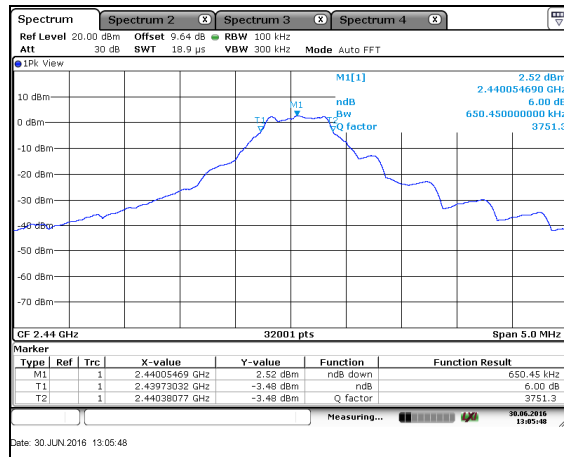

Figure 7.3.2-2: 6dB Bandwidth Plot – MCH

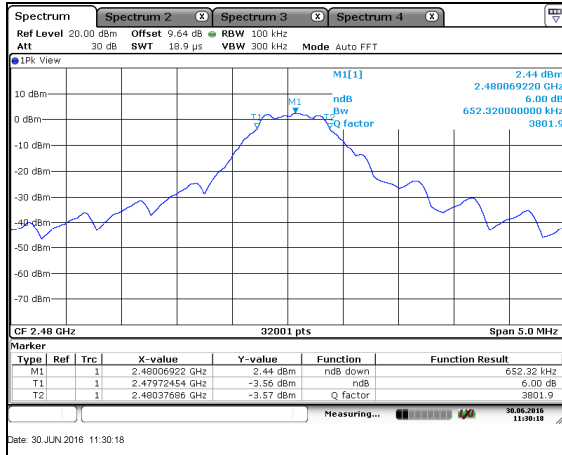

Figure 7.3.2-3: 6dB Bandwidth Plot – HCH

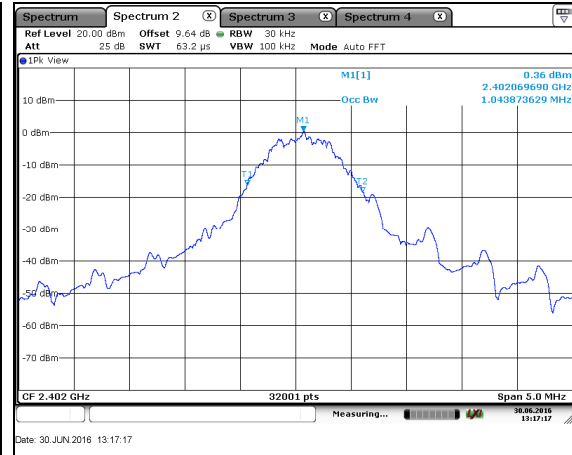

Figure 7.3.2-4: 99% Bandwidth Plot – LCH

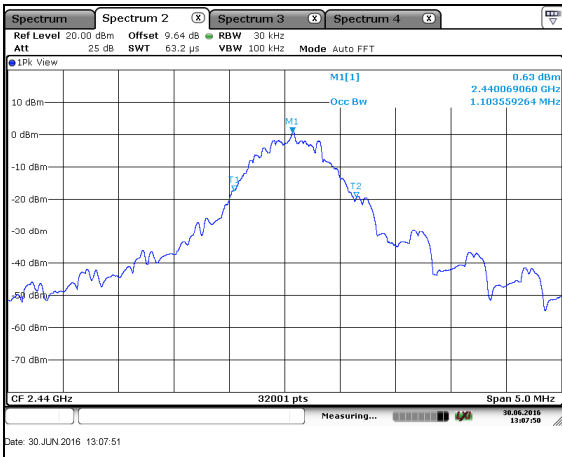

Figure 7.3.2-5: 99% Bandwidth Plot – MCH

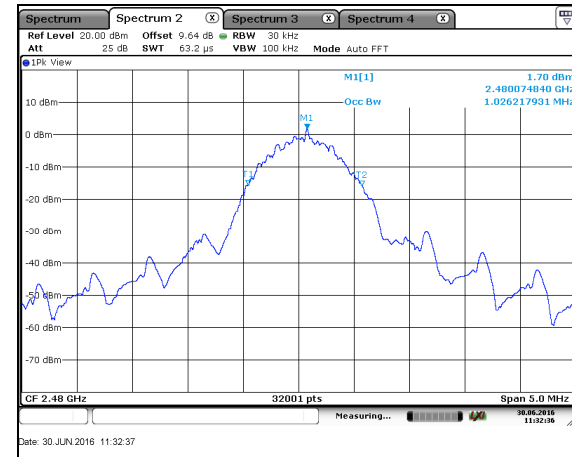

Figure 7.3.2-6: 99% Bandwidth Plot – HCH

7.4 Fundamental Emission Output Power – FCC 15.247(b)(3), ISED Canada: RSS-247 5.4(4)**7.4.1 Measurement Procedure**

The maximum peak conducted output power was measured in accordance with FCC KDB 558074 D01 DTS Meas Guidance utilizing the PKPM1 Peak power meter method. The RF output of the equipment under test was directly connected to the input of the power meter applying suitable attenuation. A peak detector was used.

7.4.2 Measurement Results**Table 7.4.2-1: Maximum Peak Conducted Output Power**

Frequency [MHz]	Level [dBm]
2402	2.65
2440	2.70
2480	2.60

7.5 Emission Levels

7.5.1 Emissions into Non-restricted Frequency Bands – FCC 15.247(d); ISED Canada: RSS-247 5.5

7.5.1.1 Measurement Procedure

The unwanted emissions into non-restricted bands were measured conducted in accordance with FCC KDB 558074 D01 DTS Meas Guidance. The RF output of the equipment under test was directly connected to the input of the spectrum analyzer applying suitable attenuation. The Resolution Bandwidth (RBW) of the spectrum analyzer was set to 100 kHz. The Video Bandwidth (VBW) was set to ≥ 300 kHz. Span was set to 1.5 times the DTS bandwidth. The trace was set to max hold with a peak detector active. The resulting spectrum analyzer peak level was used to determine the reference level with respect to the 20 dBc limit. The spectrum span was then adjusted for the measurement of spurious emissions from 30MHz to 25GHz, 10 times the highest fundamental frequency.

Band-edge compliance was determined using the conducted marker-delta method in which the radio frequency power that is produced by the EUT is at least 20 dB below that in the 100 kHz bandwidth within the band that contains the highest level of desired power.

7.5.1.2 Measurement Results

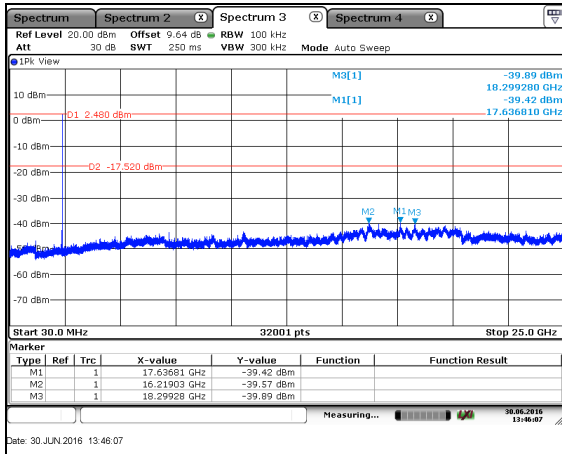

Figure 7.5.1.2-1: 30 MHz – 25 GHz – LCH

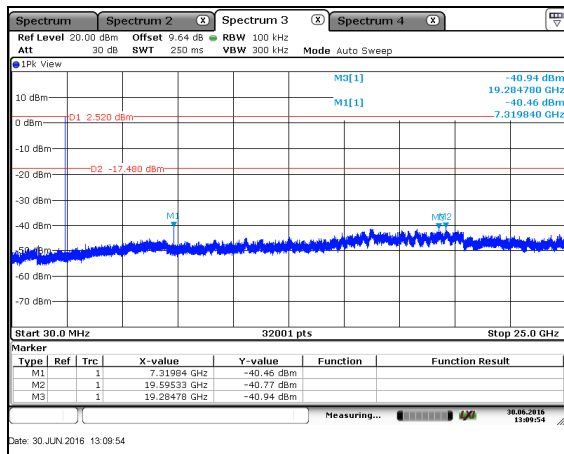

Figure 7.5.1.2-2: 30 MHz – 25 GHz – MCH

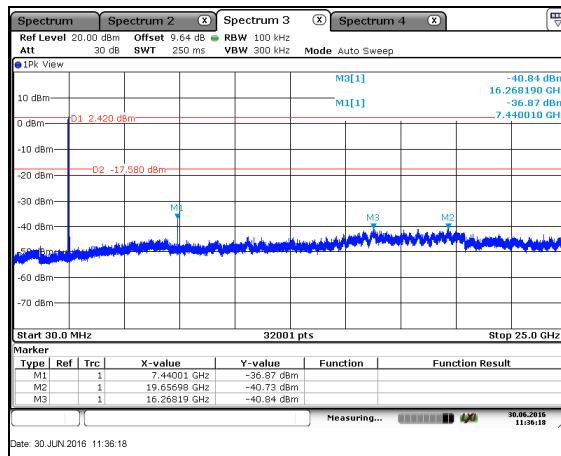

Figure 7.5.1.2-3: 30 MHz – 25 GHz – HCH

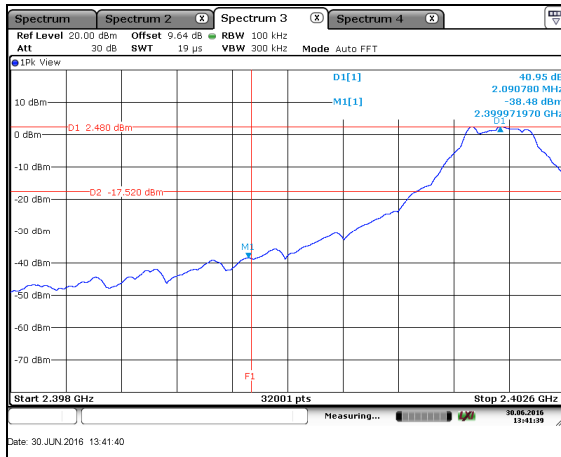

Figure 7.5.1.2-4: Lower Band-edge - LCH

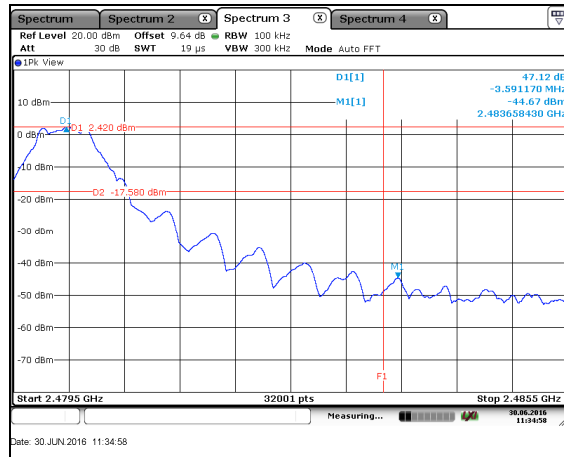

Figure 7.5.1.2-5: Upper Band-edge - HCH

7.5.2 Emissions into Restricted Frequency Bands – FCC: 15.205, 15.209; ISED Canada: RSS-GEN 8.9/8.10

7.5.2.1 Measurement Procedure

The unwanted emissions into restricted bands were measured radiated over the frequency range of 30MHz to 25GHz, 10 times the highest fundamental frequency.

The EUT was rotated through 360° and the receive antenna height was varied from 1m to 4m so that the maximum radiated emissions level would be detected. For frequencies below 1000MHz, quasi-peak measurements were made using a RBW of 120 kHz and a VBW of 300 kHz. For frequencies above 1000MHz, peak and average measurements were made with RBW and VBW of 1 MHz and 3 MHz respectively.

Each emission found to be in a restricted band as defined by section 15.205, including any emission at the operational band-edge, was compared to the radiated emission limits as defined in section 15.209.

7.5.2.2 Measurement Results

Table 7.5.2.2-1: Radiated Spurious Emissions Tabulated Data

Frequency (MHz)	Level (dBuV)		Antenna Polarity (H/V)	Correction Factors (dB)	Corrected Level (dBuV/m)		Limit (dBuV/m)		Margin (dB)	
	pk	Qpk/Avg			pk	Qpk/Avg	pk	Qpk/Avg	pk	Qpk/Avg
Low Channel										
2374	58.90	34.65	H	-5.80	53.10	28.85	74.0	54.0	20.9	25.1
2374	56.72	34.62	V	-5.80	50.92	28.82	74.0	54.0	23.1	25.2
4804	57.12	43.79	H	1.47	58.59	45.26	74.0	54.0	15.4	8.7
4804	58.06	44.15	V	1.47	59.53	45.62	74.0	54.0	14.5	8.4
Middle Channel										
4880	55.09	47.45	H	1.70	56.79	49.15	74.0	54.0	17.2	4.9
4880	55.67	48.39	V	1.70	57.37	50.09	74.0	54.0	16.6	3.9
High Channel										
2483.5	52.67	35.92	H	-5.27	47.40	30.65	74.0	54.0	26.6	23.4
2483.5	47.34	34.67	V	-5.27	42.07	29.40	74.0	54.0	31.9	24.6
4960	54.32	47.98	H	1.94	56.26	49.92	74.0	54.0	17.7	4.1
4960	55.29	49.22	V	1.94	57.23	51.16	74.0	54.0	16.8	2.8

7.5.2.3 Sample Calculation:

$$R_C = R_U + CF_T$$

Where:

CF_T = Total Correction Factor (AF+CA+AG)-DC (Average Measurements Only)

R_U = Uncorrected Reading

R_C = Corrected Level

AF = Antenna Factor

CA = Cable Attenuation

AG = Amplifier Gain

DC = Duty Cycle Correction Factor

Example Calculation: Peak

Corrected Level: $58.90 - 5.80 = 53.10\text{dBuV/m}$

Margin: $74.0\text{dBuV/m} - 53.10\text{dBuV/m} = 20.9\text{dB}$

Example Calculation: Average

Corrected Level: $34.65 - 5.80 - 0 = 28.85\text{dBuV}$

Margin: $54.0\text{dBuV} - 28.85\text{dBuV} = 25.1\text{dB}$

**7.6 Maximum Power Spectral Density in the Fundamental Emission – FCC 15.247(e)
ISED Canada: RSS-247 5.2(2)**

7.6.1 Measurement Procedure

The power spectral density was measured in accordance with the FCC KDB 558074 D01 DTS Meas Guidance utilizing the PKPSD (peak PSD) method. The RF output of the equipment under test was directly connected to the input of the spectrum analyzer applying suitable attenuation. The Resolution Bandwidth (RBW) of the spectrum analyzer was set to 3 kHz. The Video Bandwidth (VBW) was set to 10 kHz. Span was set to 1.5 times the occupied bandwidth. The trace was set to max hold with a peak detector active.

7.6.2 Measurement Results

Table 7.6.2-1: Peak Power Spectral Density

Frequency (MHz)	PSD Level (dBm)
2402	-9.47
2440	-9.71
2480	-9.26

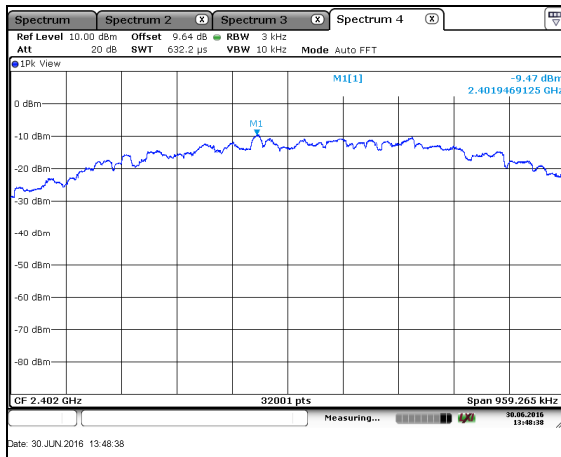

Figure 7.6.2-1: PSD Plot – LCH

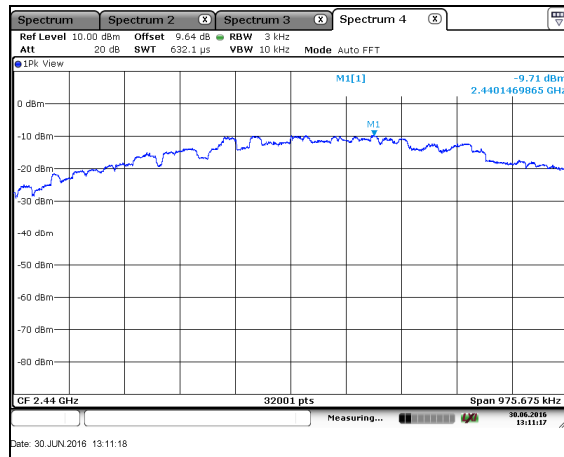

Figure 7.6.2-2: PSD Plot – MCH

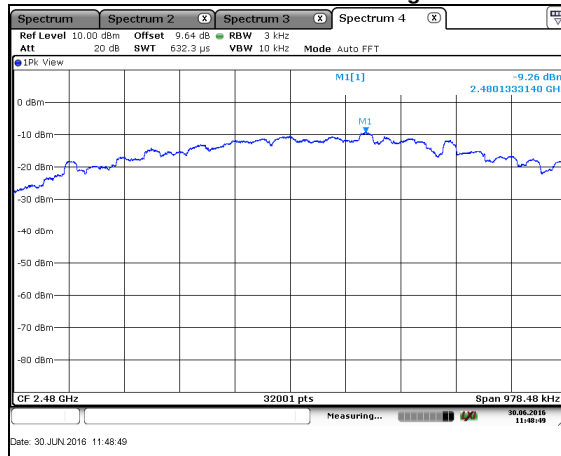

Figure 7.6.2-3: PSD Plot – HCH

8 CONCLUSION

In the opinion of TUV SUD America the KP-9000D, manufactured by QSR Automations, Inc. meets the requirements of FCC Part 15 subpart C and ISED Canada's Radio Standards Specification RSS-247.

END REPORT