



FCC 47 CFR PART 15 SUBPART C

CERTIFICATION TEST REPORT

FOR

Wireless Charger

MODEL NUMBER: BEX4756-XX

REPORT NUMBER: 11436518E

FCC ID: 2AJX5-BEX4756

ISSUE DATE: November 7, 2016

Prepared for
Byrne Electrical Specialists Inc.
320 Byrne Industrial Dr.
Rockford, MI 49341
USA

Prepared by
UL LLC
333 Pfingsten Rd.
Northbrook, IL 60062
TEL: (847) 272-8800



NVLAP Lab code: 100414-0

Revision History

Rev.	Issue Date	Revisions	Revised By
--		Initial Issue	

TABLE OF CONTENTS

1. ATTESTATION OF TEST RESULTS	4
2. TEST METHODOLOGY	5
3. FACILITIES AND ACCREDITATION	5
4. CALIBRATION AND UNCERTAINTY	5
4.1. <i>MEASURING INSTRUMENT CALIBRATION</i>	<i>5</i>
4.2. <i>SAMPLE CALCULATION</i>	<i>5</i>
4.3. <i>MEASUREMENT UNCERTAINTY</i>	<i>5</i>
5. EQUIPMENT UNDER TEST	6
5.1. <i>DESCRIPTION OF EUT</i>	<i>6</i>
5.2. <i>MAXIMUM OUTPUT POWER</i>	<i>6</i>
5.3. <i>DESCRIPTION OF AVAILABLE ANTENNAS</i>	<i>6</i>
5.4. <i>TEST CONFIGURATIONS</i>	<i>6</i>
5.5. <i>MODE(S) OF OPERATION</i>	<i>6</i>
5.6. <i>SOFTWARE AND FIRMWARE</i>	<i>6</i>
5.7. <i>WORST-CASE CONFIGURATION AND MODE</i>	<i>7</i>
5.8. <i>MODIFICATIONS</i>	<i>7</i>
5.9. <i>DESCRIPTION OF TEST SETUP</i>	<i>7</i>
6. TEST AND MEASUREMENT EQUIPMENT	9
7. RADIATED EMISSION TEST RESULTS	10
7.1. <i>LIMITS AND PROCEDURE</i>	<i>10</i>
8. AC MAINS LINE CONDUCTED EMISSIONS	18
9. SETUP PHOTOS	23

1. ATTESTATION OF TEST RESULTS

COMPANY NAME: Byrne Electrical Specialists Inc.
320 Byrne Industrial Dr.
Rockford, MI 49341
USA

EUT DESCRIPTION: Wireless Charger

MODEL: BEX4756-XX

SERIAL NUMBER: non-serialized

DATE TESTED: September 26, 2016 – November 7, 2016

APPLICABLE STANDARDS	
STANDARD	TEST RESULTS
FCC PART 15 SUBPART C	Pass

UL LLC tested the above equipment in accordance with the requirements set forth in the above standards. All indications of Pass/Fail in this report are opinions expressed by UL LLC based on interpretations and/or observations of test results. Measurement Uncertainties were not taken into account and are published for informational purposes only. The test results show that the equipment tested is capable of demonstrating compliance with the requirements as documented in this report.

Note: The results documented in this report apply only to the tested sample, under the conditions and modes of operation as described herein. This document may not be altered or revised in any way unless done so by UL LLC and all revisions are duly noted in the revisions section. Any alteration of this document not carried out by UL LLC will constitute fraud and shall nullify the document. This report must not be used by the client to claim product certification, approval, or endorsement by NVLAP, NIST, any agency of the Federal Government, or any agency of any government.

Approved & Released For
UL LLC By:



Bob DeLisi
WiSE Principal Engineer
UL LLC

Tested By:



Bart Mucha
WiSE Staff Engineer
UL LLC

2. TEST METHODOLOGY

The tests documented in this report were performed in accordance with ANSI C63.10-2013, FCC CFR 47 Part 2, FCC CFR 47 Part 15.

3. FACILITIES AND ACCREDITATION

The test sites and measurement facilities used to collect data are located at 333 Pfingsten Road, Northbrook, IL 60062 USA.

UL NBK is accredited by NVLAP, Laboratory Code 100414-0. The full scope of accreditation can be viewed at <http://ts.nist.gov/>

4. CALIBRATION AND UNCERTAINTY

4.1. MEASURING INSTRUMENT CALIBRATION

The measuring equipment utilized to perform the tests documented in this report has been calibrated in accordance with the manufacturer's recommendations, and is traceable to recognized national standards.

4.2. SAMPLE CALCULATION

Sample Calculations

Radiated Field Strength and Conducted Emissions data contained within this report is calculated on the following basis:

Field Strength (dBuV/m) = Meter Reading (dBuV) + AF (dB/m) - Gain (dB) + Cable Loss (dB)

Conducted Voltage (dBuV) = Meter Reading (dBuV) + Cable Loss (dB) + LISN IL (dB)

Conducted Current (dBuA) = Meter Reading (dBuV) + Cable Loss (dB) - Transducer Factor (dBohms)

4.3. MEASUREMENT UNCERTAINTY

Where relevant, the following measurement uncertainty levels have been estimated for tests performed on the apparatus:

Test	Range	Equipment	Uncertainty k=2
Conducted Emissions	9k-150kHz	LISN	3.84dB
Conducted Emissions	150k-30MHz	LISN	3.65dB
Radiated Emissions	9k-30MHz	H-Field Loop	3.15dB
Radiated Emissions	30-200MHz	Bicon 10m Horz	4.48dB
Radiated Emissions	30-200MHz	Bicon 10m Vert	4.49dB
Radiated Emissions	200-1000MHz	LogP 10m Horz	3.79dB
Radiated Emissions	200-1000MHz	LogP 10m Vert	3.84dB

Uncertainty figures are valid to a confidence level of 95%.

5. EQUIPMENT UNDER TEST

5.1. DESCRIPTION OF EUT

The EUT is a Wireless Qi Charger with two separate charging coils and two USB 5V outputs (maximum 1A each). Device is installed in single orientation only as part of a desk / table.

5.2. MAXIMUM OUTPUT POWER

The transmitter has a maximum peak radiated output as follows:

Frequency Range (MHz)	Mode	Output Field Strength dBuV/m	Measurement Distance (meters)
0.110 - 0.205	Charging	82.62	3.00

* the maximum output field strength is recorded at 3m distance. The Maximum level is for single coil only (reporting the highest emission). During testing both coils were active, and each operated as slightly different frequency. See section 7.1 for test data.

5.3. DESCRIPTION OF AVAILABLE ANTENNAS

The radio utilizes an coil antenna

5.4. TEST CONFIGURATIONS

The following configurations were investigated:

EUT Configuration	Description
1	EUT with wireless loads (receiving coils with resistors and maximum power) and with USB loads (1A each).
2	EUT without loads

5.5. MODE(S) OF OPERATION

Mode	Description
1	EUT putting out full maximum power to wireless loads and resistors on USB ports
2	EUT powered but not charging (no loads)

5.6. SOFTWARE AND FIRMWARE

none

5.7. WORST-CASE CONFIGURATION AND MODE

EUT was tested with receiving coil terminated into resistors providing maximum load.

5.8. MODIFICATIONS

No modifications were made during testing.

5.9. DESCRIPTION OF TEST SETUP

SUPPORT EQUIPMENT

Support Equipment List				
Description	Manufacturer	Model	Serial Number	FCC ID
Qi Loads	Byrne Electrical Specialists.	None	none	none
Resistive Loads - 50Hm resistor	-	-	-	-

I/O CABLES

I/O Cable List						
Cable No	Port	# of identical ports	Connector Type	Cable Type	Cable Length (m)	Remarks
1	AC Input	1	-	3-wire	1.5m	none
2	AC Outputs	1	-	-	-	none
3	USB Outputs	2	SUB	USB	-	Terminated with resistors

TEST SETUP

The EUT was installed in a typical configuration. Refer to the following diagram.

SETUP DIAGRAM FOR TESTS

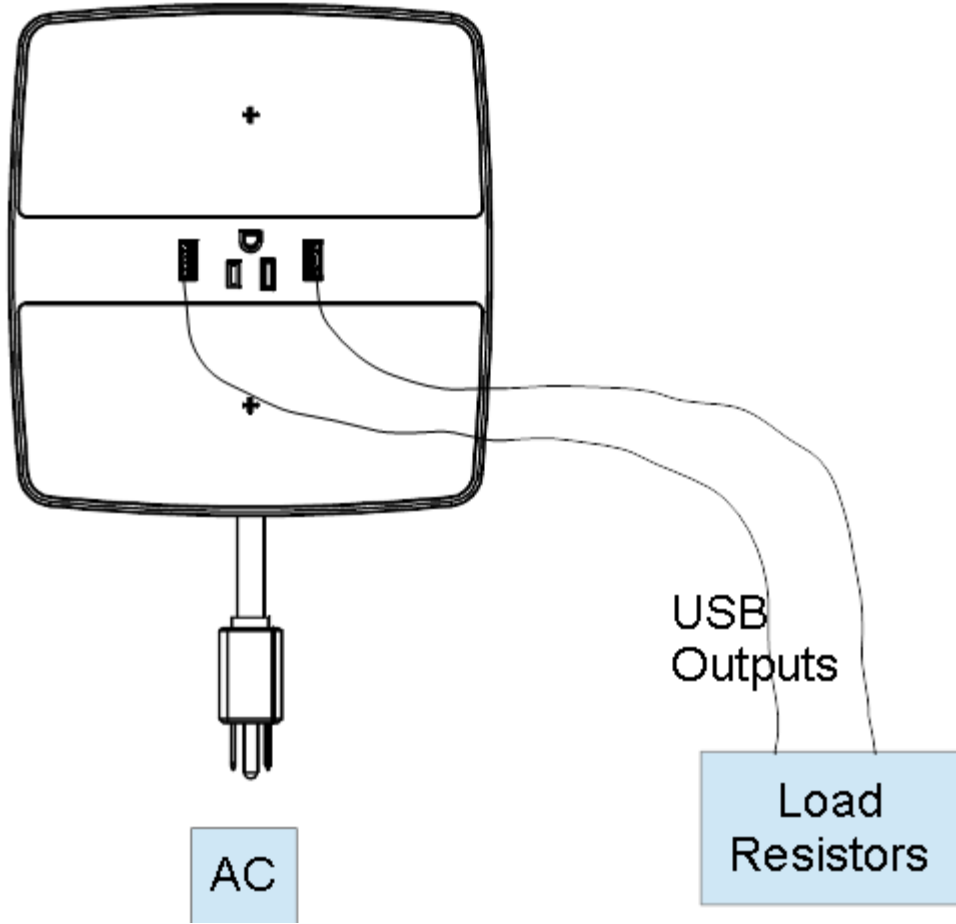

6. TEST AND MEASUREMENT EQUIPMENT

The following test and measurement equipment was utilized for the tests documented in this report:

Test Equipment List					
Description	Manufacturer	Model	Eq. No.	Cal Date	Cal Due
Radiated Software	UL	UL EMC	Ver 9.5, July 22, 2014		
Conducted Software	UL	UL EMC	Ver 9.5, May 17 2012		
EMI Test Receiver	Rohde & Schwarz	ESCI	EMC4328	20151118	20161118
Bicon Antenna	Chase	VBA6106A	EMC4078	20151228	20161231
Log-P Antenna	Chase	UPA6109	EMC4313	20160122	20170131
Loop Antenna	EMCO	6502/1	EMC4026	20160722	20170731
EMI Test Receiver	Rohde & Schwarz	ESR	EMC4377	20160426	20170426
Transient Limiter	Electro-Metrics	EM7600-2	EMC4224	N/A	N/A
HighPass Filter	Solar Electronics	2803-150	885551	N/A	N/A
Attenuator	HP	8494B	2831A00838	N/A	N/A
LISN - L1	Solar	8602-50-TS-50-N	EMC4052	20160216	20170228
LISN - L2	Solar	8602-50-TS-50-N	EMC4064	20160216	20170228

7. RADIATED EMISSION TEST RESULTS

7.1. LIMITS AND PROCEDURE

LIMITS

FCC §15.209 (a)

Frequency (MHz)	Field Strength (microvolts/meter)	Measurement Distance (m)	Limit dBuV/m
0.009–0.490	2400/F(kHz)	300	128.5 – 93.8 @3m
0.490–1.705	24000/F(kHz)	30	73.8 – 63.0 @ 3m
1.705–30.0	30	30	69.5 – 69.5 @ 3m
30–88	100	3	40.0 @ 3m
88 to 216	150	3	43.5 @ 3m
216 to 960	200	3	46.0 @ 3m
Above 960 MHz	500	3	54.0 @ 3m
Note: The lower limit shall apply at the transition frequency.			

TEST PROCEDURE

The EUT is placed on a non-conducting table 80 cm above the ground plane for below 1GHz measurements. The antenna to EUT distance is 3 meters.

For measurements below 1 GHz the resolution bandwidth is set to 120 kHz for peak detection measurements or 120 kHz for quasi-peak detection measurements for the 30-1000 MHz range, 9 kHz for peak detection measurements or 9 kHz for quasi-peak detection measurements for the 0.15-30 MHz range and 200 Hz for peak detection measurements or 200 Hz for quasi-peak detection measurements for the 9 to 150 kHz range. Peak detection is used unless otherwise noted as quasi-peak.

The spectrum from 9kHz to 1 GHz is investigated with the transmitter constantly transmitting into a fixed load to ensure maximum current draw from the charger.

The frequency range of interest is monitored at a fixed antenna height and EUT azimuth. The EUT is rotated through 360 degrees to maximize emissions received. Measurements are made with the antenna positioned at 0° and 90° in vertical polarization and in a horizontal polarization to the ground plane.

Although measurements were made on a test site other than an open area site, comparisons between an open area site and the chamber have been made to show that measurements in the chamber correlate to those on an open area site.

RESULTS

TX FUNDAMENTAL AND SPURIOUS EMISSIONS 0.009kHz TO 30 MHz Charging Mode

Antenna Parallel to EUT

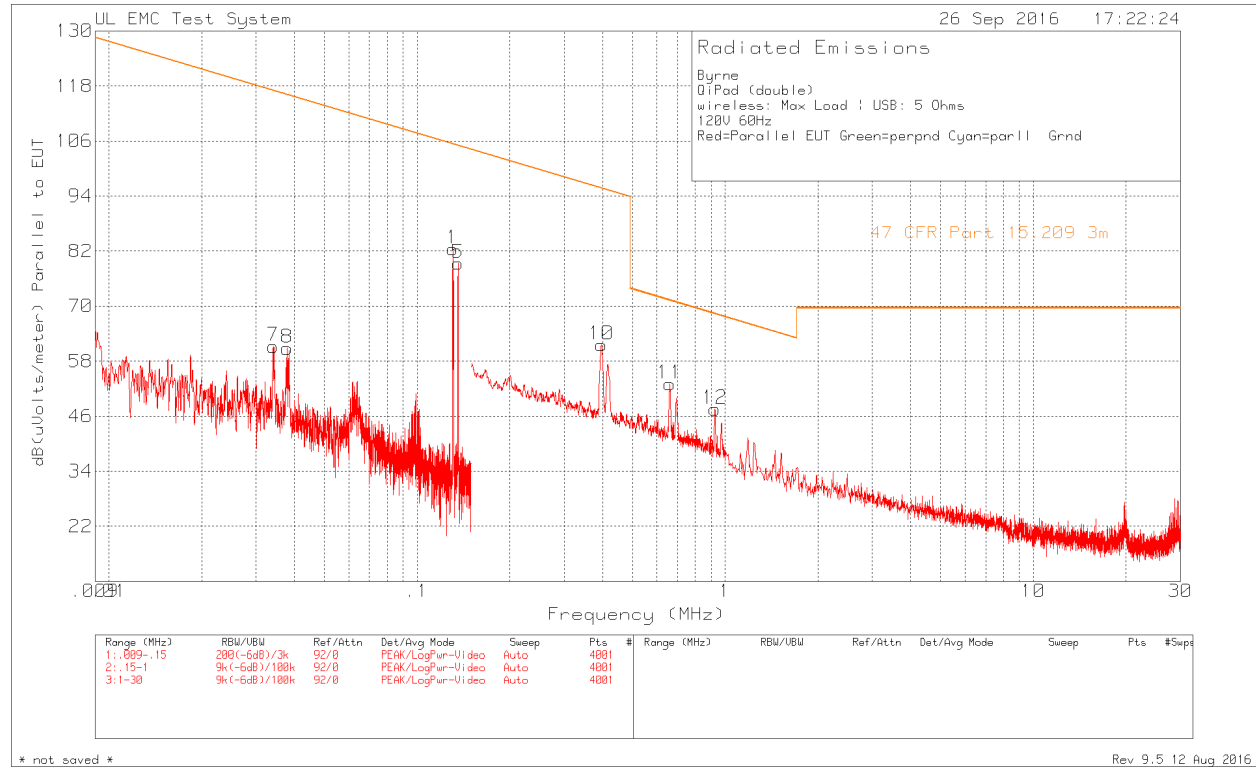

Antenna Parallel to Ground

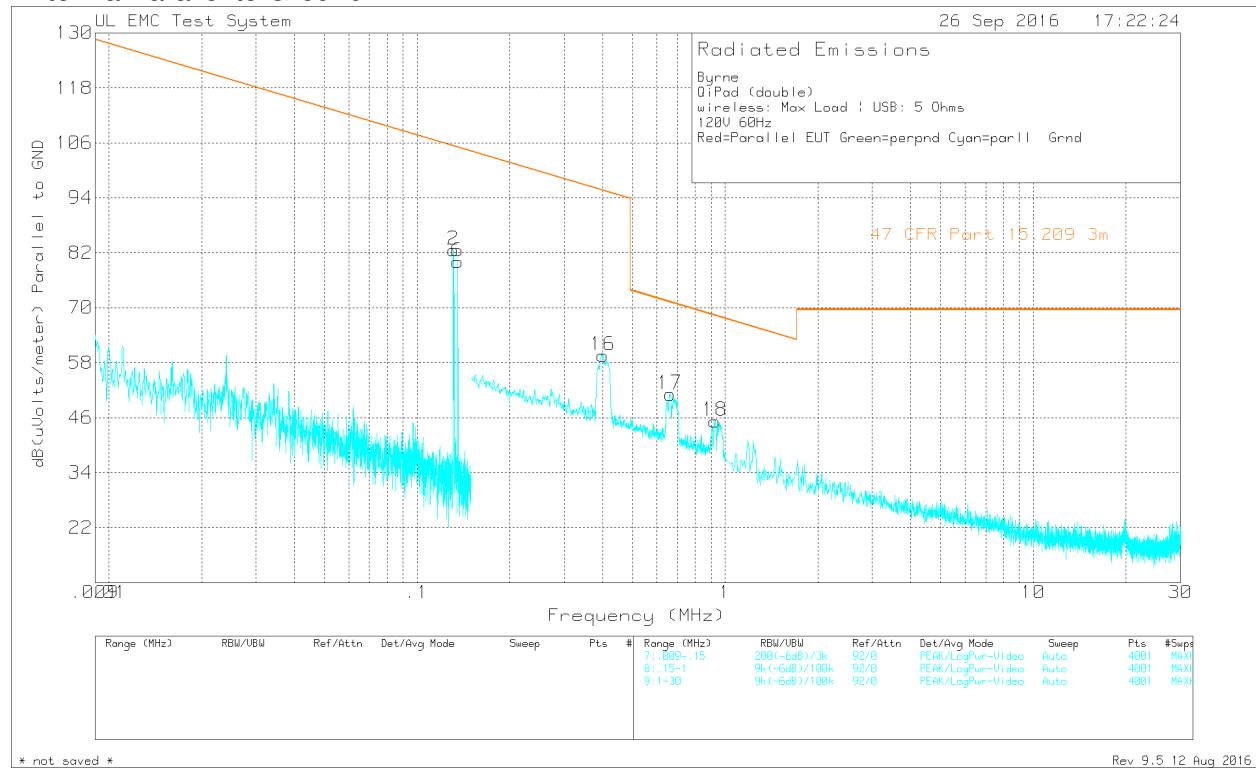

Antenna Perpendicular to EUT

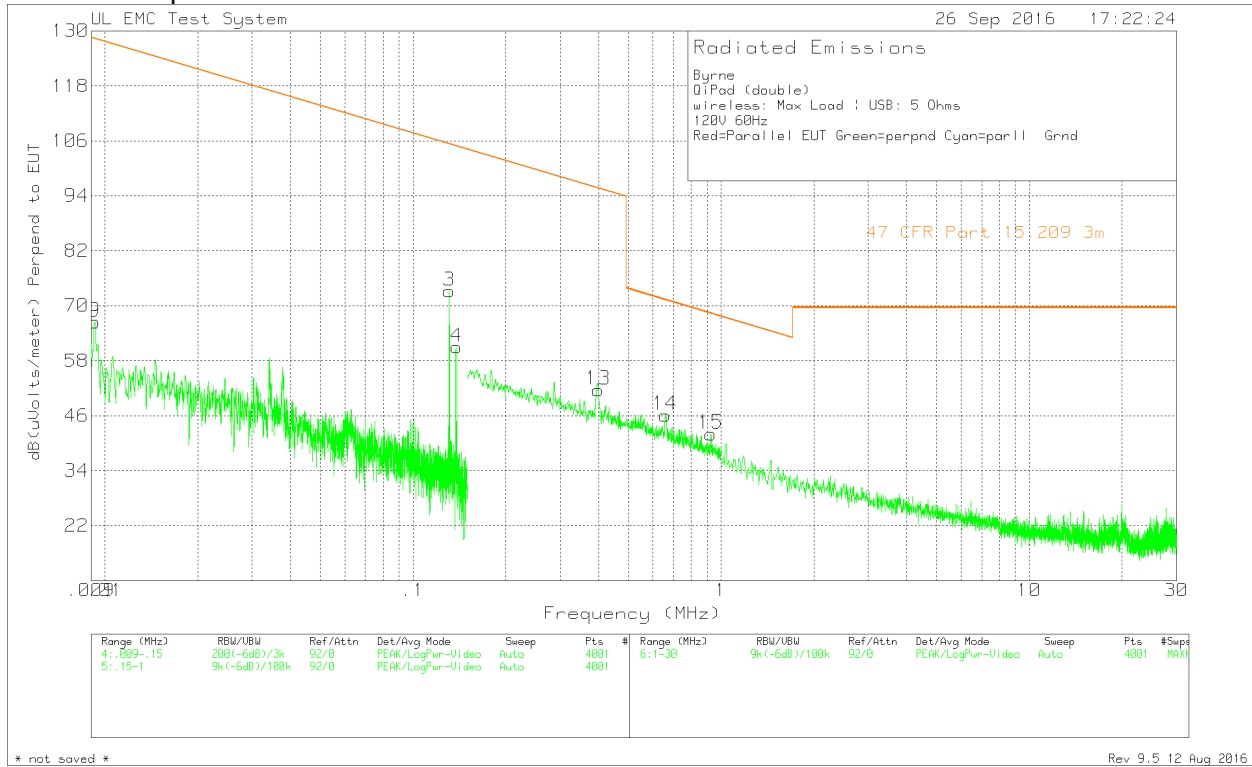

Radiated Emissions Data

Byrne
 QiPad (double)
 wireless: Max Load | USB: 5 Ohms
 120V 60Hz
 Red=Parallel EUT Green=perpnd Cyan=parll Grnd

Trace Markers

Test No.	Frequency (MHz)	Meter Reading	Transducer Factor (dB)	Gain/Loss Factor (dB)	Corrected Reading dB (uVolts/meter)	Limit:1
=====						
Parallel to EUT						
1	.13052	71.09dBuV Pk	11.4	0	82.49	105.28
		Azimuth:0-360	Height:101		Margin (dB)	-22.79
5	.13588	67.9dBuV Pk	11.4	0	79.3	104.94
		Azimuth:0-360	Height:101		Margin (dB)	-25.64
7	.0341	46.63dBuV Pk	14.6	0	61.23	116.94
		Azimuth:0-360	Height:101		Margin (dB)	-55.71
8	.03784	46.71dBuV Pk	14.1	0	60.81	116.03
		Azimuth:0-360	Height:101		Margin (dB)	-55.22
10	.39633	50.25dBuV Pk	11.3	0	61.55	95.64
		Azimuth:0-360	Height:101		Margin (dB)	-34.09
11	.66056	41.63dBuV Pk	11.4	0	53.03	71.21
		Azimuth:0-360	Height:101		Margin (dB)	-18.18
12	.92532	36.05dBuV Pk	11.4	.1	47.55	68.28
		Azimuth:0-360	Height:101		Margin (dB)	-20.73
Perpendicular to Ground						
3	.13098	61.79dBuV Pk	11.4	0	73.19	105.25
		Azimuth:0-360	Height:101		Margin (dB)	-32.06
4	.13854	49.69dBuV Pk	11.3	0	60.99	104.77
		Azimuth:0-360	Height:101		Margin (dB)	-43.78
9	.00928	44.37dBuV Pk	22.1	0	66.47	128.23
		Azimuth:0-360	Height:101		Margin (dB)	-61.76
13	.39878	40.36dBuV Pk	11.3	0	51.66	95.59
		Azimuth:0-360	Height:101		Margin (dB)	-43.93
14	.65715	34.72dBuV Pk	11.4	0	46.12	71.25
		Azimuth:0-360	Height:101		Margin (dB)	-25.13
15	.92521	30.5dBuV Pk	11.4	.1	42	68.28
		Azimuth:0-360	Height:101		Margin (dB)	-26.28
Parallel to GND						
2	.13112	71.22dBuV Pk	11.4	0	82.62	105.24
		Azimuth:0-360	Height:101		Margin (dB)	-22.62
6	.13542	68.61dBuV Pk	11.4	0	80.01	104.96
		Azimuth:0-360	Height:101		Margin (dB)	-24.95
16	.40113	48.31dBuV Pk	11.3	0	59.61	95.54
		Azimuth:0-360	Height:101		Margin (dB)	-35.93
17	.66205	39.72dBuV Pk	11.4	0	51.12	71.19
		Azimuth:0-360	Height:101		Margin (dB)	-20.07
18	.92553	33.76dBuV Pk	11.4	.1	45.26	68.28
		Azimuth:0-360	Height:101		Margin (dB)	-23.02

LIMIT 1: 47 CFR Part 15.209 3m
 Pk - Peak detector

RESTRICTED BANDEDGE EMISSIONS

Bandedge measurements were conducted using radiated field strength and 20dBc points. Attempt was made to move the device up and down and around the charging pad. This caused the impedance of the load to change and maximum range of frequencies was used. Special Attention was paid to 110kHz.

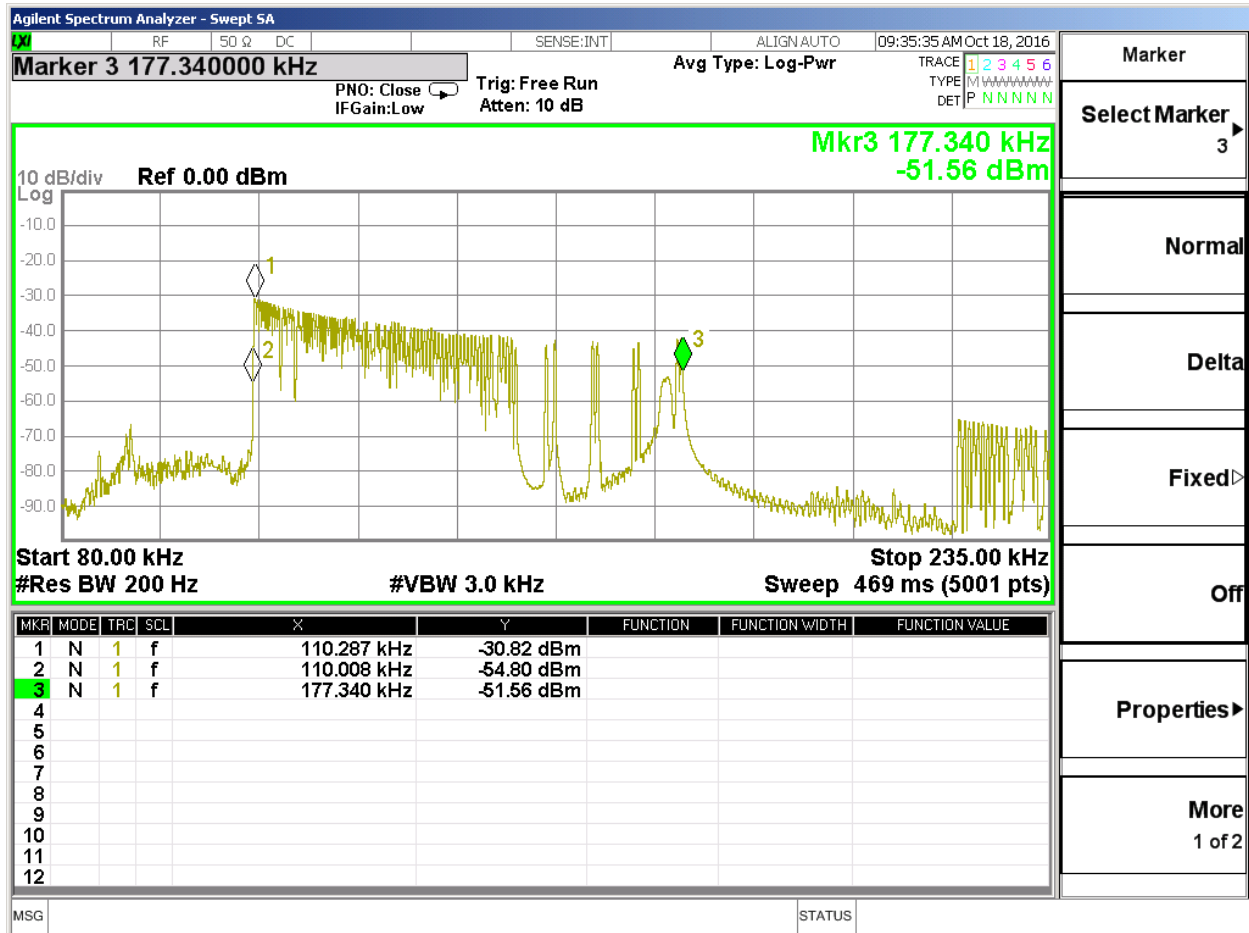

TX SPURIOUS EMISSIONS 30MHz TO 1GHz Charging Mode

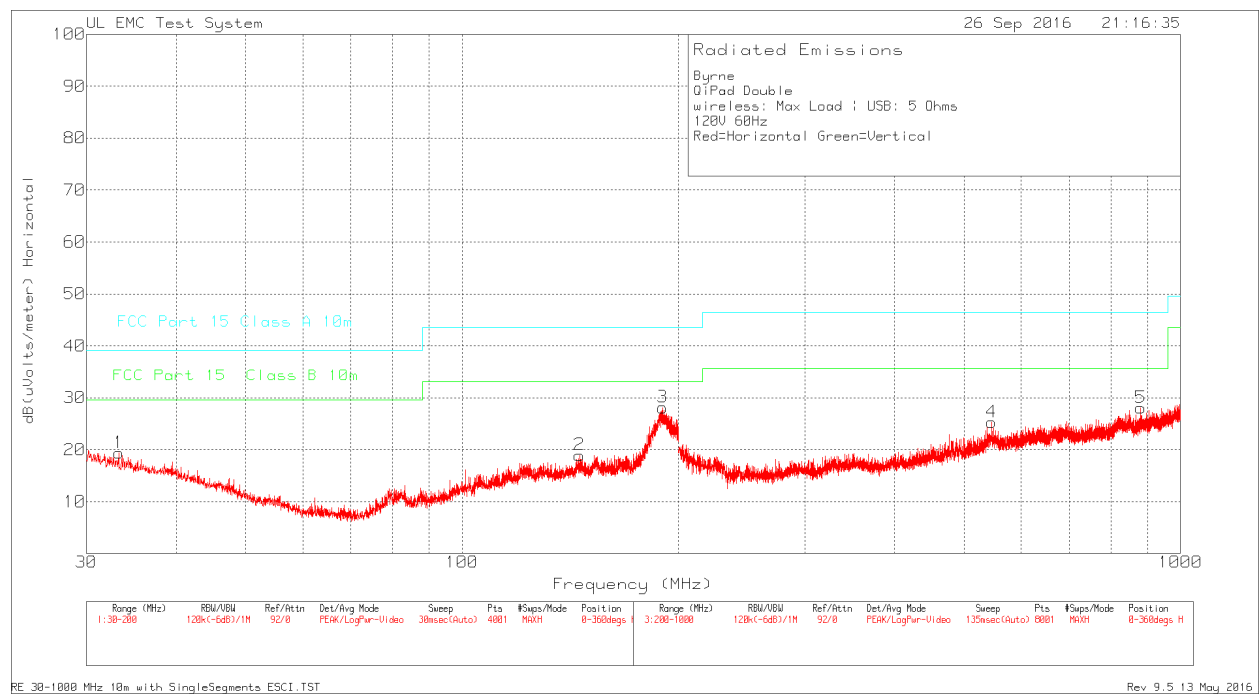
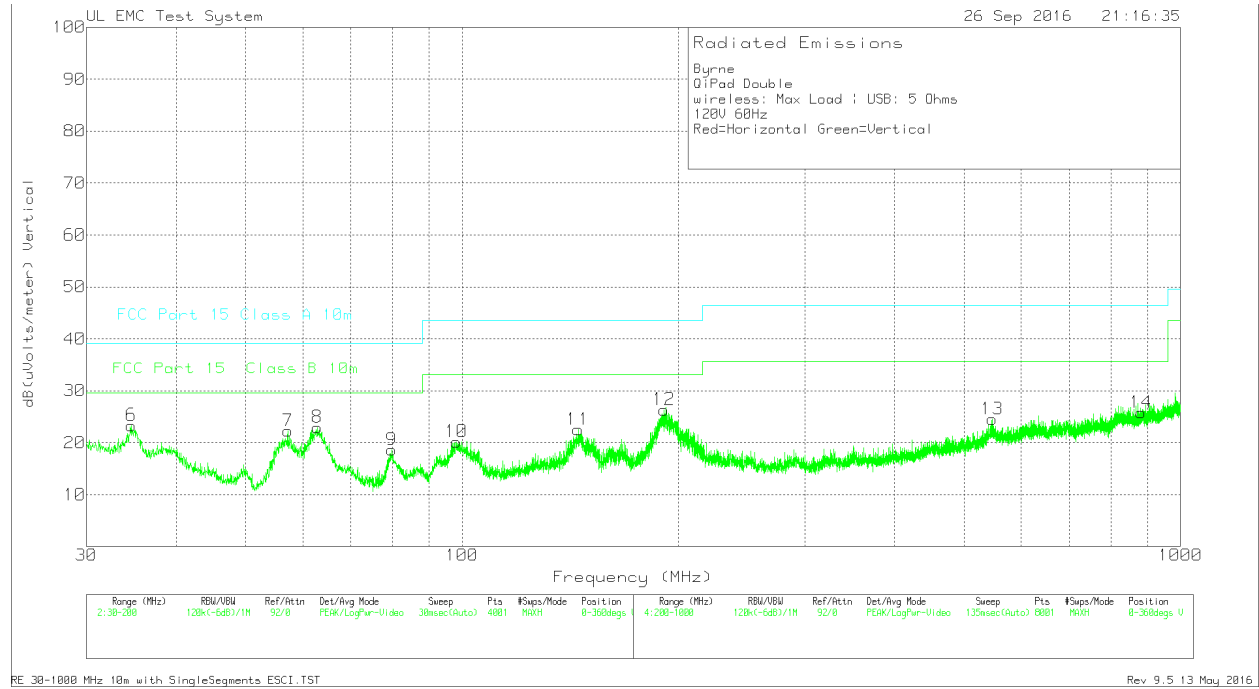

Byrne
 QiPad Double
 wireless: Max Load | USB: 5 Ohms
 120V 60Hz
 Red=Horizontal Green=Vertical

Trace Markers

No.	Test Frequency (MHz)	Meter Reading	Transducer Factor (dB)	Gain/Loss Factor (dB)	Corrected Reading dB (uVolts/meter)	Limit:1	2
1	33.2725	32.5dBuV Pk	16.9	-30	19.4	39.08	29.55
		Azimuth:0-360	Height:249	Horz	Margin (dB)	-19.68	-10.15
2	145.685	34.26dBuV Pk	14.3	-29.6	18.96	43.52	33.07
		Azimuth:0-360	Height:398	Horz	Margin (dB)	-24.56	-14.11
3	190.2675	41.14dBuV Pk	16	-29	28.14	43.52	33.07
		Azimuth:0-360	Height:398	Horz	Margin (dB)	-15.38	-4.93
6	34.675	37.04dBuV Pk	16.3	-30	23.34	39.08	29.55
		Azimuth:0-360	Height:101	Vert	Margin (dB)	-15.74	-6.21
7	57.2	44.47dBuV Pk	7.8	-30	22.27	39.08	29.55
		Azimuth:0-360	Height:251	Vert	Margin (dB)	-16.81	-7.28
8	62.8525	46.36dBuV Pk	6.6	-30	22.96	39.08	29.55
		Azimuth:0-360	Height:251	Vert	Margin (dB)	-16.12	-6.59
9	79.8525	41.21dBuV Pk	7.3	-29.9	18.61	39.08	29.55
		Azimuth:0-360	Height:398	Vert	Margin (dB)	-20.47	-10.94
10	98.1275	39.59dBuV Pk	10.4	-29.8	20.19	43.52	33.07
		Azimuth:0-360	Height:101	Vert	Margin (dB)	-23.33	-12.88
11	145.0475	37.9dBuV Pk	14.2	-29.6	22.5	43.52	33.07
		Azimuth:0-360	Height:101	Vert	Margin (dB)	-21.02	-10.57
12	190.905	39.25dBuV Pk	16	-28.9	26.35	43.52	33.07
		Azimuth:0-360	Height:101	Vert	Margin (dB)	-17.17	-6.72
4	546.1	32.81dBuV Pk	20.1	-27.6	25.31	46.44	35.57
		Azimuth:0-360	Height:199	Horz	Margin (dB)	-21.13	-10.26
5	880.3	32.98dBuV Pk	22.8	-27.7	28.08	46.44	35.57
		Azimuth:0-360	Height:299	Horz	Margin (dB)	-18.36	-7.49
13	547.2	32.17dBuV Pk	20	-27.6	24.57	46.44	35.57
		Azimuth:0-360	Height:302	Vert	Margin (dB)	-21.87	-11
14	881	30.67dBuV Pk	22.8	-27.7	25.77	46.44	35.57
		Azimuth:0-360	Height:199	Vert	Margin (dB)	-20.67	-9.8

Pk - Peak detector

Radiated Emission Data

Test Frequency (MHz)	Meter Reading	Transducer Factor (dB)	Gain/Loss Factor (dB)	Corrected Reading dB (uVolts/meter)	Limit:1	2
189.8583	34.74dBuV Qp	16	-29	21.74	43.52	33.07
	Azimuth: 1	Height:373	Horz	Margin (dB):	-21.78	-11.33

LIMIT 1: FCC Part 15 Class A 10m
 LIMIT 2: FCC Part 15 Class B 10m

Qp - Quasi-Peak detector

DIGITAL RADIATED EMISSIONS 30 MHz TO 1GHz Charging Mode

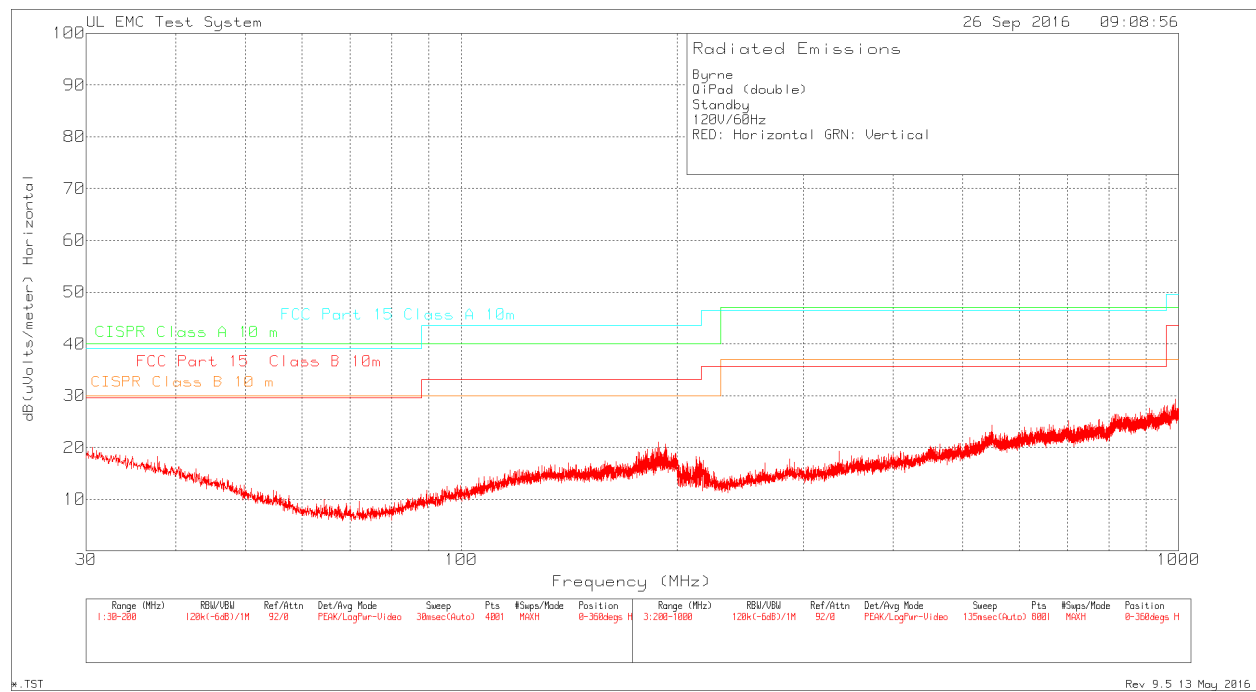
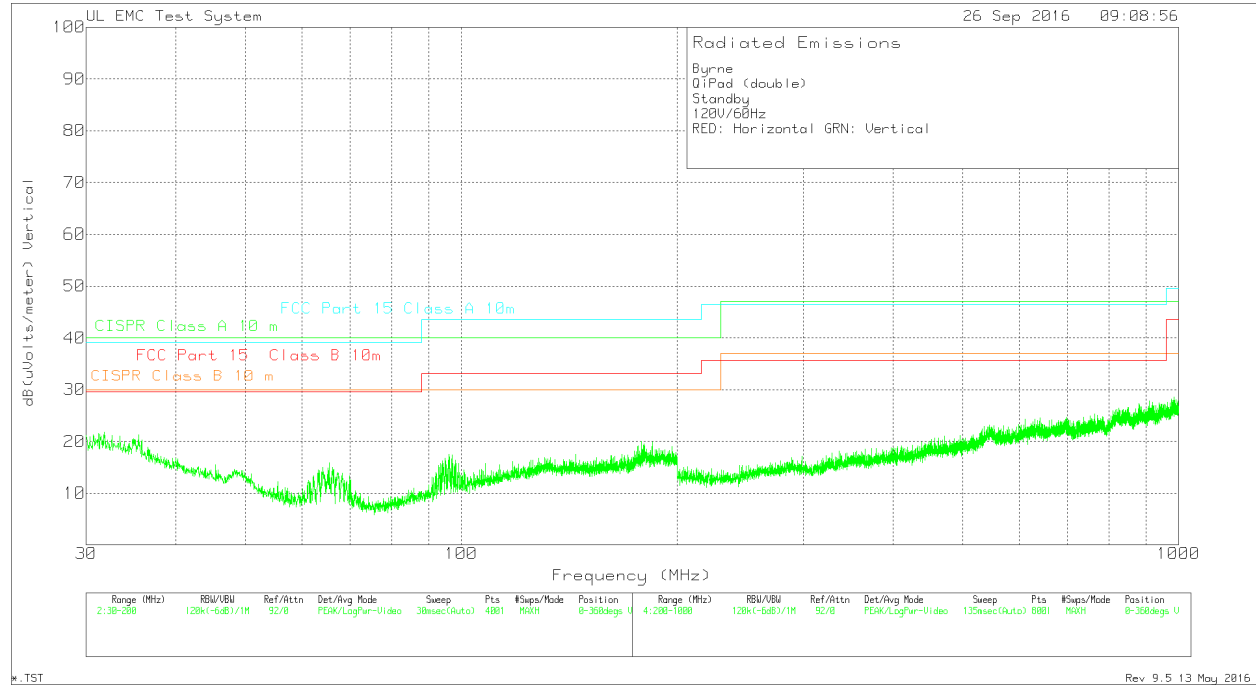

* no emissions within 6dB from the limit, measurements not needed.

8. AC MAINS LINE CONDUCTED EMISSIONS

LIMITS

§15.207 (a)

Frequency of emission (MHz)	Conducted Limit (dB μ V)	
	Quasi-peak	Average
0.15 to 0.50	66 to 56*	56 to 46*
0.50 to 5	56	46
5 to 30	60	50

* Decreases with the logarithm of the frequency.

TEST PROCEDURE

ANSI C63.10

RESULTS

No non-compliance noted:

Line Conducted Emissions – Charging Mode

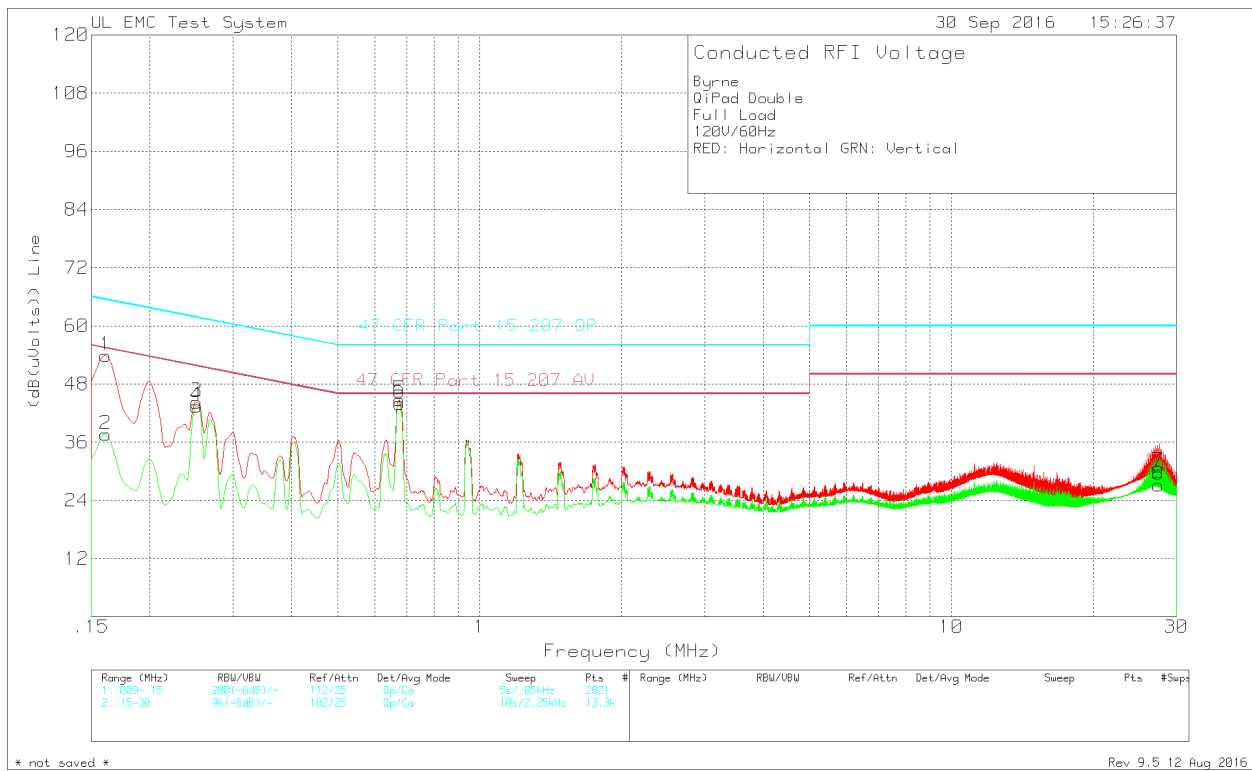
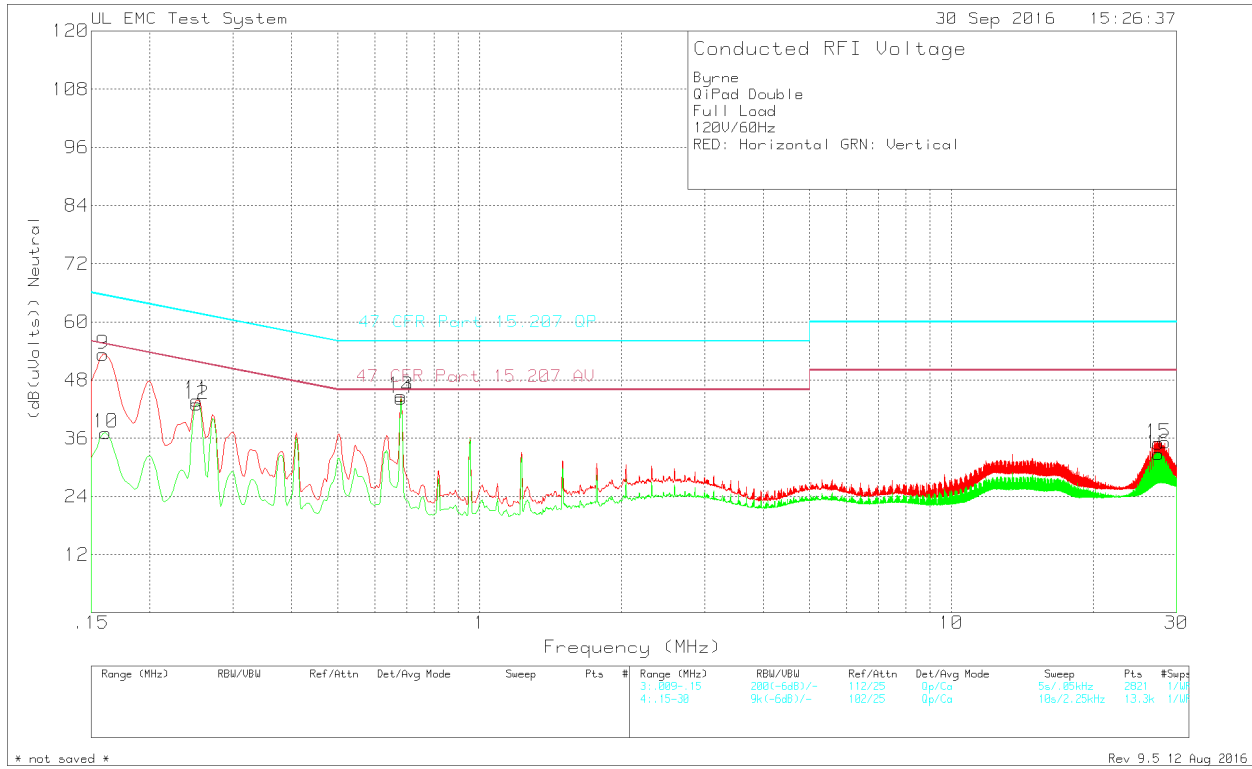

Byrne
 QiPad Double
 Full Load
 120V/60Hz
 RED: Horizontal GRN: Vertical

Trace Markers						
No.	Test Frequency (MHz)	Meter Reading	Transducer Factor (dB)	Gain/Loss Factor (dB)	Corrected Reading (dB(uVolts))	Limit:1 2
=====						
Line						
1	.16125	43.46dBuV Qp	.1	10.3	53.86	65.4 55.4
					Margin (dB)	-11.54 -1.54
2	.16125	27.21dBuV Ca	.1	10.3	37.61	65.4 55.4
					Margin (dB)	-27.79 -17.79
3	.25125	33.98dBuV Qp	0	10.3	44.28	61.72 51.72
					Margin (dB)	-17.44 -7.44
4	.25125	33.16dBuV Ca	0	10.3	43.46	61.72 51.72
					Margin (dB)	-18.26 -8.26
5	.6765	34.44dBuV Qp	0	10.3	44.74	56 46
					Margin (dB)	-11.26 -1.26
6	.6765	33.74dBuV Ca	0	10.3	44.04	56 46
					Margin (dB)	-11.96 -1.96
7	27.47175	18.07dBuV Qp	0	11.9	29.97	60 50
					Margin (dB)	-30.03 -20.03
8	27.47175	15.29dBuV Ca	0	11.9	27.19	60 50
					Margin (dB)	-32.81 -22.81
Neutral						
9	.159	42.91dBuV Qp	.1	10.3	53.31	65.52 55.52
					Margin (dB)	-12.21 -2.21
10	.16125	26.75dBuV Ca	.1	10.3	37.15	65.4 55.4
					Margin (dB)	-28.25 -18.25
11	.25125	33.56dBuV Qp	0	10.3	43.86	61.72 51.72
					Margin (dB)	-17.86 -7.86
12	.25125	32.74dBuV Ca	0	10.3	43.04	61.72 51.72
					Margin (dB)	-18.68 -8.68
13	.681	34.47dBuV Qp	0	10.3	44.77	56 46
					Margin (dB)	-11.23 -1.23
14	.681	33.93dBuV Ca	0	10.3	44.23	56 46
					Margin (dB)	-11.77 -1.77
15	27.47738	22.91dBuV Qp	0	12.1	35.01	60 50
					Margin (dB)	-24.99 -14.99
16	27.4785	20.75dBuV Ca	0	12.1	32.85	60 50
					Margin (dB)	-27.15 -17.15

LIMIT 1: 47 CFR Part 15.207 QP
 LIMIT 2: 47 CFR Part 15.207 AV

Qp - Quasi-Peak detector
 Ca - CISPR Average detection

Line Conducted Emissions – Standby Mode

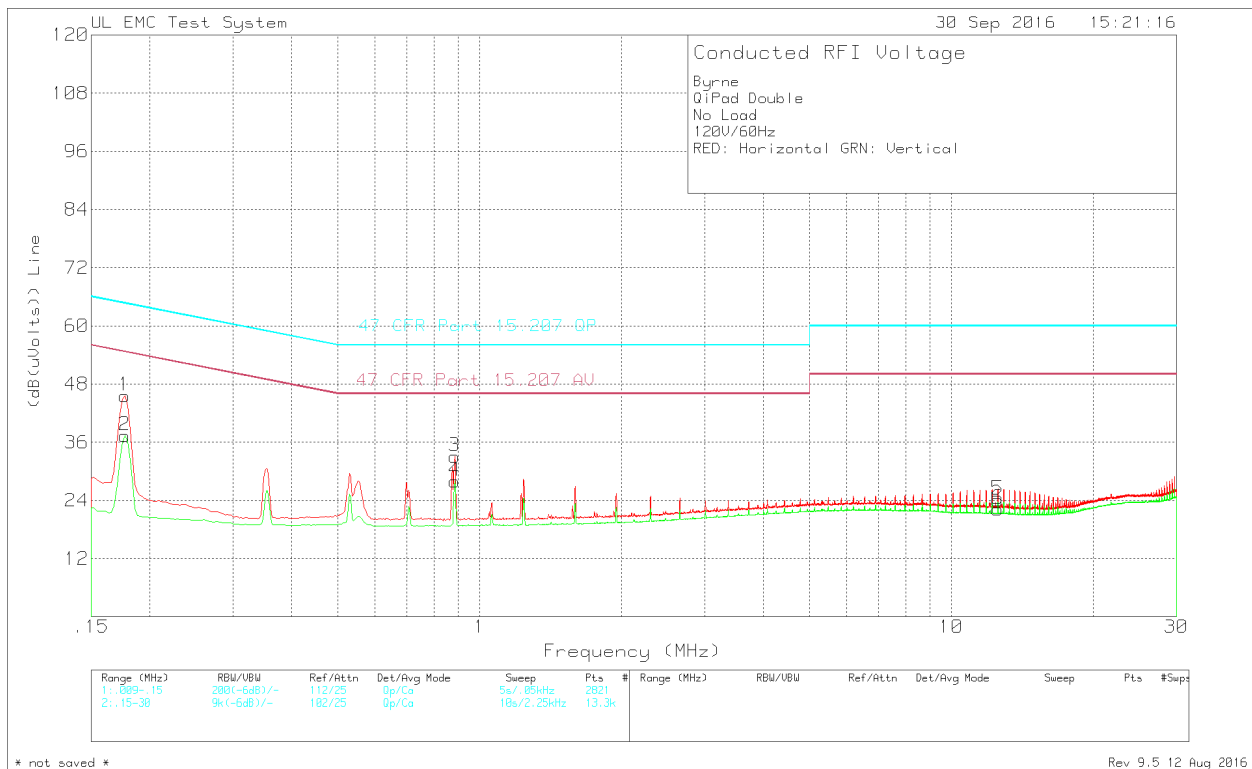
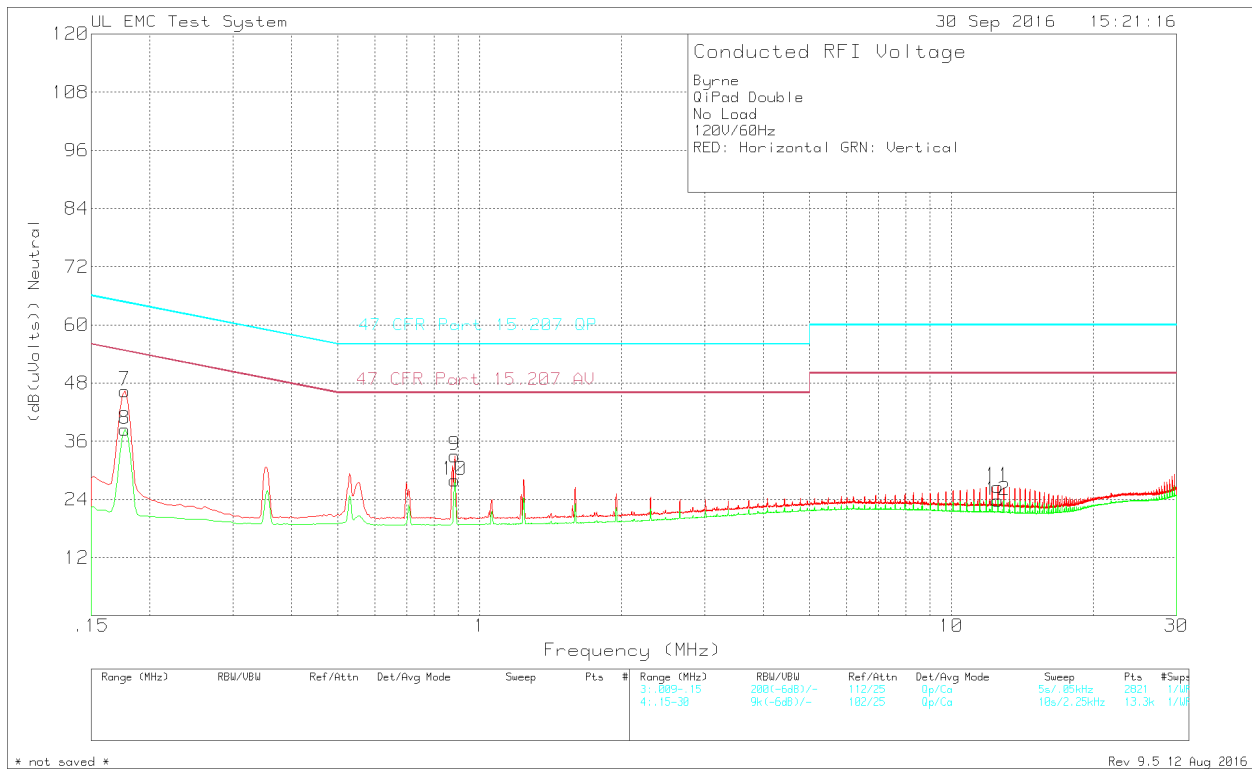

Byrne
 QiPad Double
 No Load
 120V/60Hz
 RED: Horizontal GRN: Vertical

Trace Markers

Test No.	Frequency (MHz)	Meter Reading	Transducer Factor (dB)	Gain/Loss Factor (dB)	Corrected Reading (dB(uVolts))	Limit:1	2
Line 1	.177	35.19dBuV Qp	.1	10.3	45.59	64.63	54.63
					Margin (dB)	-19.04	-9.04
2	.177	27dBuV Ca	.1	10.3	37.4	64.63	54.63
					Margin (dB)	-27.23	-17.23
3	.88575	22.77dBuV Qp	0	10.3	33.07	56	46
					Margin (dB)	-22.93	-12.93
4	.88575	17.67dBuV Ca	0	10.3	27.97	56	46
					Margin (dB)	-28.03	-18.03
5	12.543	13.03dBuV Qp	.1	11	24.13	60	50
					Margin (dB)	-35.87	-25.87
6	12.543	11.14dBuV Ca	.1	11	22.24	60	50
					Margin (dB)	-37.76	-27.76
Neutral							
7	.177	36.01dBuV Qp	.1	10.3	46.41	64.63	54.63
					Margin (dB)	-18.22	-8.22
8	.177	28.08dBuV Ca	.1	10.3	38.48	64.63	54.63
					Margin (dB)	-26.15	-16.15
9	.88575	22.73dBuV Qp	0	10.3	33.03	56	46
					Margin (dB)	-22.97	-12.97
10	.88575	17.66dBuV Ca	0	10.3	27.96	56	46
					Margin (dB)	-28.04	-18.04
11	12.5475	15.57dBuV Qp	.1	11	26.67	60	50
					Margin (dB)	-33.33	-23.33
12	12.5475	12.7dBuV Ca	.1	11	23.8	60	50
					Margin (dB)	-36.2	-26.2

LIMIT 1: 47 CFR Part 15.207 QP
 LIMIT 2: 47 CFR Part 15.207 AV

Qp - Quasi-Peak detector
 Ca - CISPR Average detection

9. SETUP PHOTOS

RADIATED EMISSION Above 30 MHz

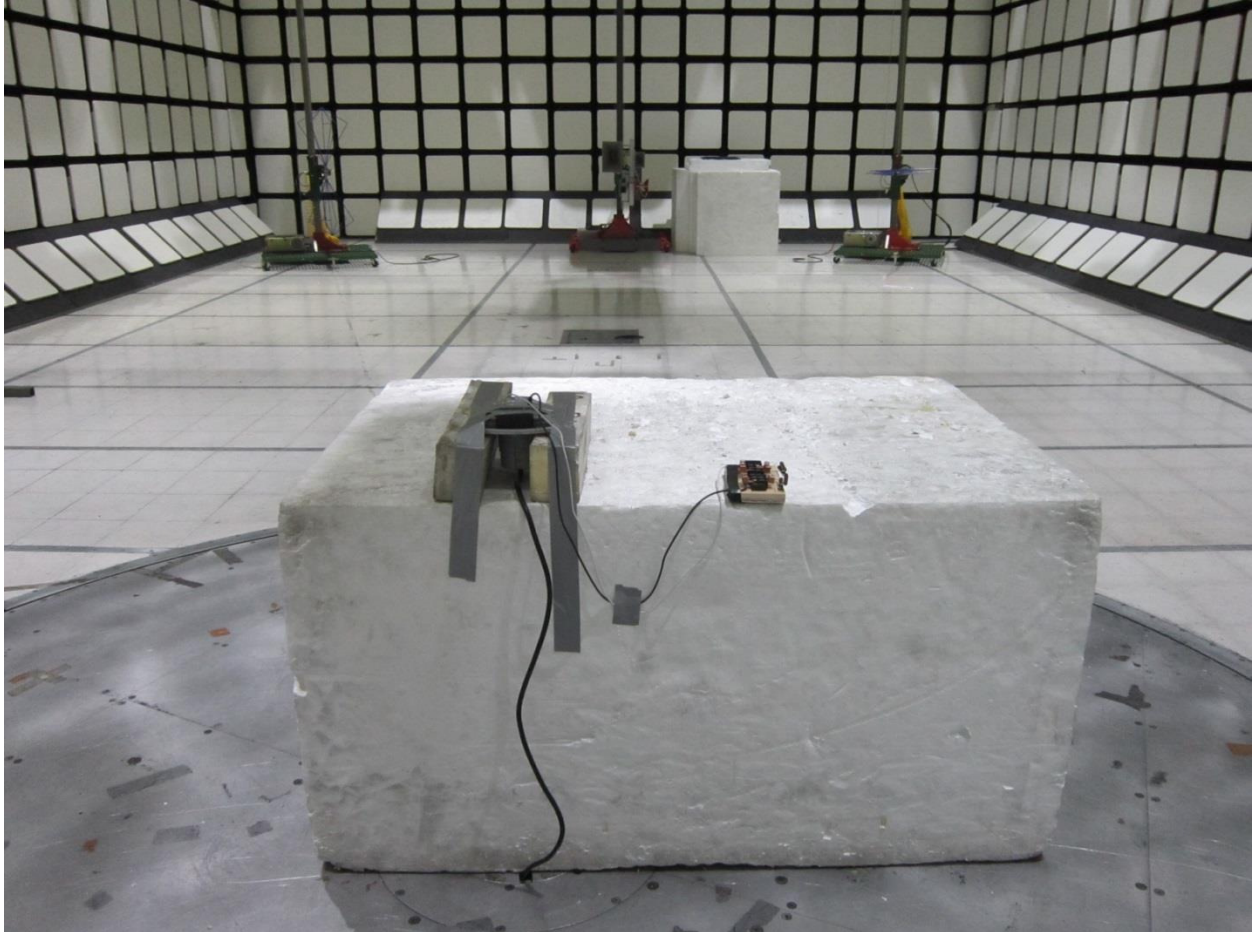

Radiated Emissions Below 30MHz

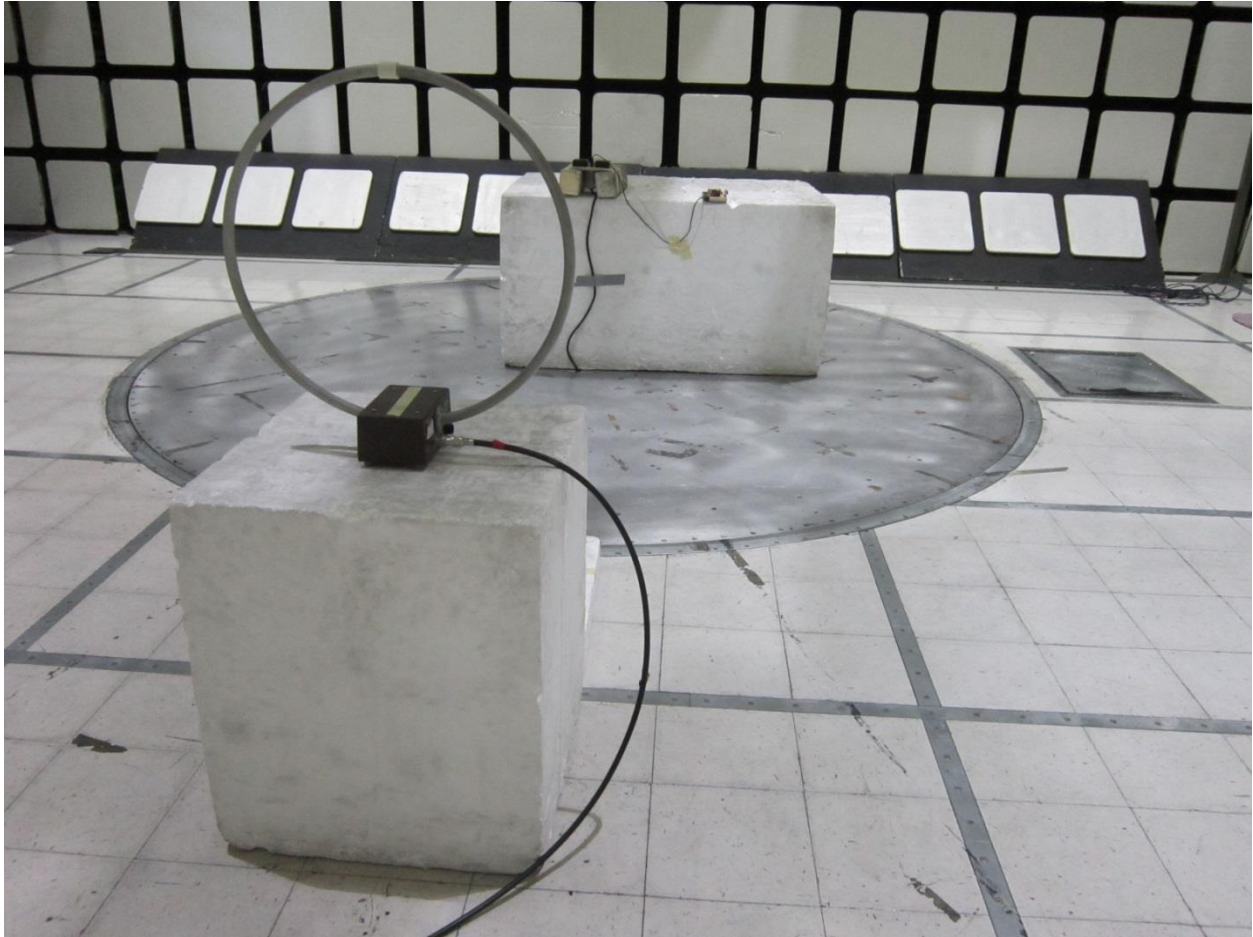

Line Conducted Emissions



END OF REPORT