

TPV Component Specification

Basic Information / 基本信息					
TPV Part No. / 料号		Supplier Part Name / 厂商型号		Part Description / 品名描述	
368GAAWA727GSD		WF7D-20-White		WIFI antenna	
Supplier Name / 厂商名称		TPV Vendor Code / 厂商代码		Manufacturing Location / 制造产地	
惠州高盛达科技有限公司		3736501		广东惠州	
Safety Parts / 安规零件			YES <input checked="" type="checkbox"/>	NO <input type="checkbox"/>	Net Weight / 净重(g) 2.4g
Environmental Guarantee / 环境保证					
<p>1. All raw materials of supplied parts shall met TPV latest version standard (RDEMS-01) and the requirement of regional or country laws and ordinances. 料件之所有原材料必须符合 TPV 环境物质管理最新版本标准(RDEMS-01)及销售国家、地区的法律法规及机型申请适用之条例。</p> <p>2. All raw materials of supplied parts shall comply below requirements (mark "√" in the "□" when needed). 料件之所有原材料必须符合以下所列项目的环保要求。必须符合的项目， "□" 中打 "√" 。</p> <p><input type="checkbox"/> HF: Low Halogen / 低卤 (氟 Cl <900ppm, 溴 Br<900ppm, Cl+Br<1500ppm), 外箱必须标识 "HF"</p> <p><input checked="" type="checkbox"/> RP: Not contained any red phosphorus</p> <p><input type="checkbox"/> VOC: 挥发性有机物(According TPV standard RDEMS-01)/(依照 TPV RDEMS-01 标准)</p>					
Important Notice / 重点说明					
<p>1. Any specification change for component, especially following items: Raw Material, Process, Tooling, Factory, Label, halftone, and any engineering changed of production, should be approved by TPV. 零件的任何变更，尤其原材、制程、模具、产地、标识、网版、以及任何生产之变更，必须得到 TPV 之承认。</p> <p>2. Any engineering change for component should be in version record, supplier should provide management information for old version parts to TPV if required. 任何零件之工程变更必须有版本记录，如需要，厂商必须提供库存之旧料管理信息状况。</p> <p>3. Safety parts should be ensured that all safety certificate is complete and in the period of validity. Any change of safety certificate should be noticed to TPV timely and phased-in after approved by TPV. 安规零件，须保证各项安规证书齐全且在有效期内。安规证书等任何变更必须及时报备 TPV，且必须得到 TPV 认可后导入。</p>					
Supplier Information / 厂商信息					
Prepared 承办	高照	Check 确认	孙燕	Approved 核准	熊运自
Tel. 电话	0752-2096932	Fax 传真	0752-2096932	Email 邮件	liangys@gaosd.com
Address 地址	广东省惠州市惠澳大道惠南高新科技产业园金达路 2 号				

TPV Component Specification

VERSION RECORD			
VERSION	DESCRIPTION OF CHANGE	OWNER	RELEASE DATE
1.0	Original Version	刘蒋军	2021-01-22

SPECIFICATION

SHEET FOR APPROVAL

(Revision: R: A1)

CUSTOMER(客户名称)	高盛达	
CS P/N(客户机种)	WF7D-20-White	
PART NAME(品名)	WIFI 天线组件	L=201mm
FREQUENCY(频率)	2400-2500MHz/5150~5850	
ZTX NO.(物料编号)	2.00004254	G.5.13.WF7DX10AGD
DATE(日期)	2021-01-22	

CUSTOMER			
QA CHECKED	ME CHECKED	RF CHECKED	MANAGER CHECKED

Remark(备注):

Sign(客户确认签字盖章): _____

ZHONG TIAN XUN TECHNOLOGY CO., LTD				
MANAGER CHECKED	MANAGER CHECKED	ME CHECKED	RF CHECKED	LISTER
		邹一麟	刘蒋军	



深圳市中天迅通信技术股份有限公司

SHENZHEN ZHONGTIAN XUN Communication Technology Co.,Ltd.

地址: 深圳市宝安区石岩镇石龙大道 34 号(腾达工业园) 邮编: 518000
电话: 0755-27588320 传真: 0755-27588045 <http://www.chinaztx.com>

ANTENNA SPECIFICATION

CUS P/N :WF7D-20-White WIFI 天线组件

ApplicationDate:Jan.22,2021

Rev: R:A1

ZTX P/N :WF7D-20-White WIFI 天线组件

Editor:

Page 1 of 12

Revision history

版本	日期	状态
A1	2021-01-22	首版



ANTENNA SPECIFICATION

CUS P/N :WF7D-20-White WIFI 天线组件

ApplicationDate:Jan.22,2021

Rev: R:A1

ZTX P/N :WF7D-20-White WIFI 天线组件

Editor:

Page 2 of 12

Index

		Revision history	1
1		Test equipment	3
2		Electrical Specifications	4
	2-1	Frequency Band	4
	2-2	VSWR And GAIN	4
3		Antenna test data	4
	3-1	VSWR	4
	3-2	mith Chart	5
	3-3	Matching circuit	5
	3-4	No-source test data	5
	3-5	Directional drawing of horizontal plane of	6~7
	3-6	3D radiation drawing	7
	3-7	产品实物图片	7
4		Mechanical Specification	8
	4-1	Mechanical Specification (WIFI)	8
	4-2	Mechanical Specification (WIFI 组件)	9
5		Environment Characteristic	10
6		The packing way	11
		附页： 出货标签模板	12



ANTENNA SPECIFICATION

CUS P/N :WF7D-20-White WIFI 天线组件
ZTX P/N :WF7D-20-White WIFI 天线组件

ApplicationDate:Jan.22,2021
Editor:

Rev: R:A1
Page 3 of 12

1. Test equipment

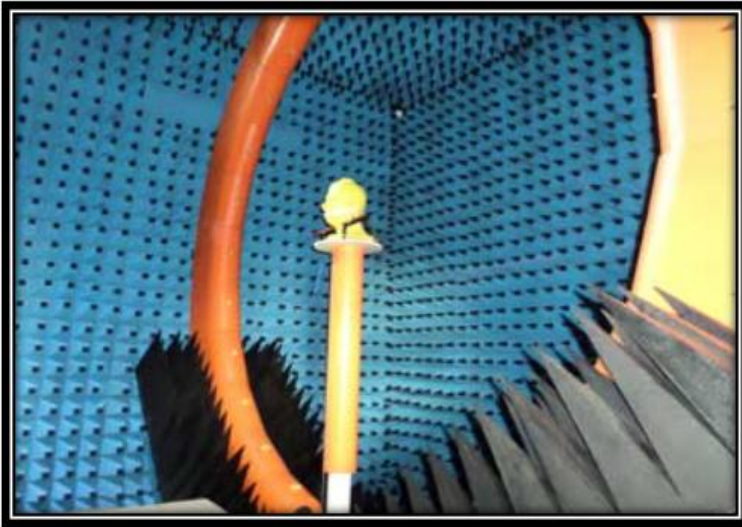

Owned 6 microwave dark room, equipped 2 sets world leading France Satimo SG24 OTA certification test systems (one in SHENZHEN, another one in Shanghai), ETS OTA Standard test system, Blue test reverberation test system which is High repeatability, high accuracy and high resolution. It can quickly provide accurate test reports, fully meet the CITA standards.

Testing range:

Support active, passive testing of
GSM/CDMA/WCDMA/TD-
SCDMA/LTE/WIFI/WLAN/WiMax/BT
/GPS/MIMO/UWB within 0.4-6G.

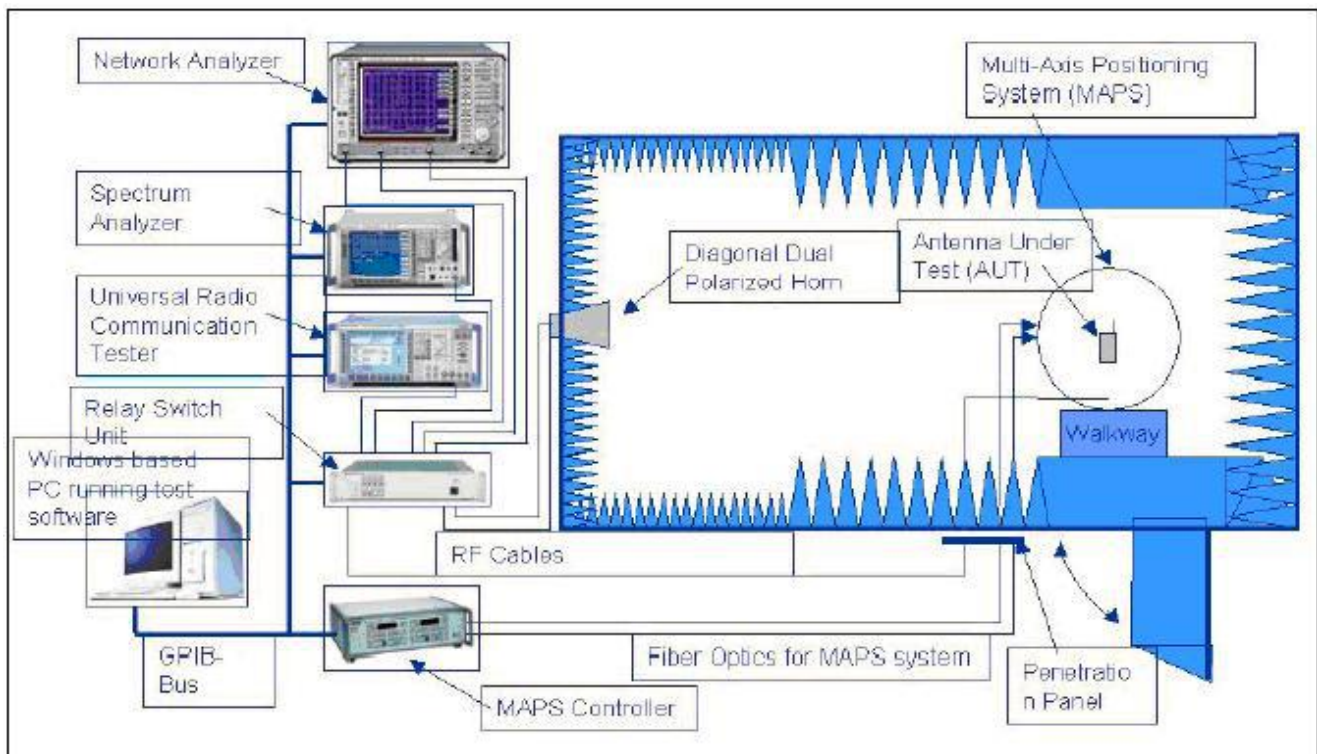

ANTENNA SPECIFICATION

CUS P/N :WF7D-20-White WIFI 天线组件

ApplicationDate:Jan.22,2021

Rev: R:A1

ZTX P/N :WF7D-20-White WIFI 天线组件

Editor:

Page 4 of 12

2. Electrical Specifications

2-1 Frequency Band

Frequency Band	Frequency
WIFI 2.4G	2400-2500MHZ
WIFI 5.8G	5150-5850MHZ

2-2 VSWR And GAIN

VSWR		GAIN	
Freq. Band	OPEN SPEC	Band Freq.	OPEN SPEC
2400MHz	≤ 2.0	2400MHz	$\geq -1.0\text{dBi}$
2500MHz	≤ 2.0	2500MHz	$\geq -1.0\text{dBi}$
5150MHz	≤ 2.0	5150MHz	$\geq -1.0\text{dBi}$
5850MHz	≤ 2.0	5850MHz	$\geq -1.0\text{dBi}$

※Measuring a 50 Ω test jig is connected to a network analyzer to measure the VSWR.

※※All test value is done in customer approval fixture.

3. Antenna test data

3-1 VSWR

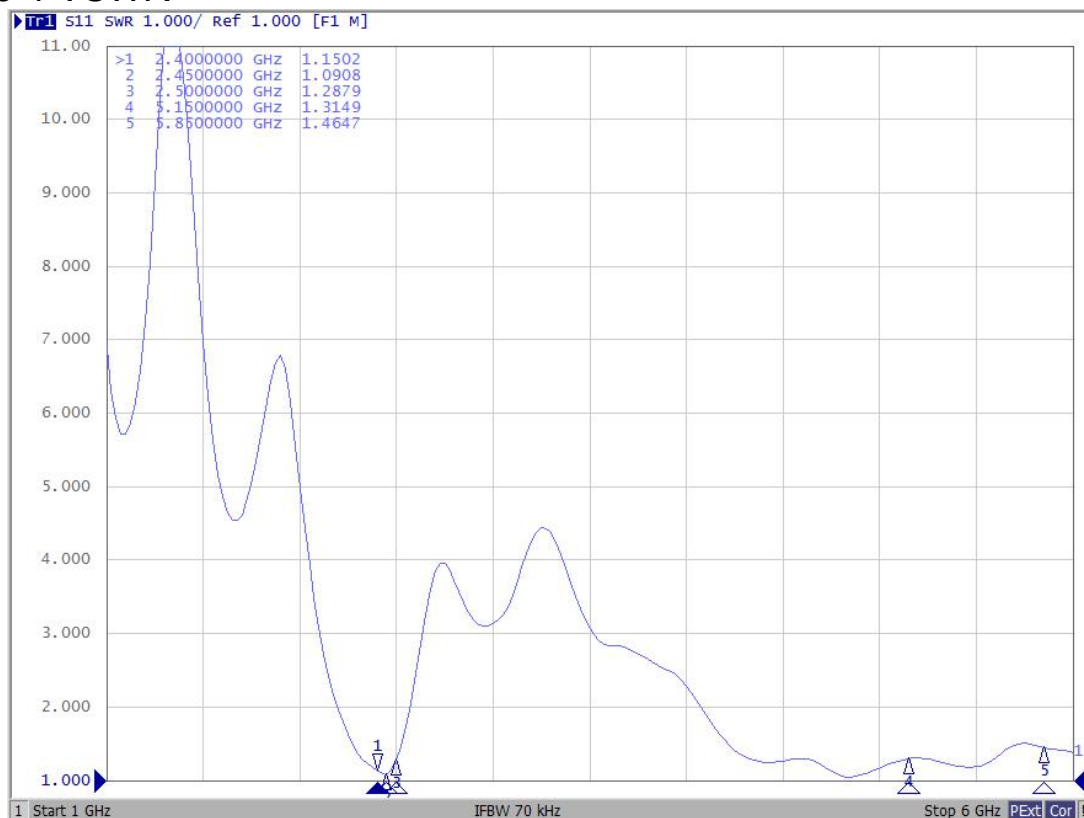

ANTENNA SPECIFICATION

CUS P/N :WF7D-20-White WIFI 天线组件

ApplicationDate:Jan.22,2021

Rev: R:A1

ZTX P/N :WF7D-20-White WIFI 天线组件

Editor:

Page 5 of 12

3-2 Smith Chart

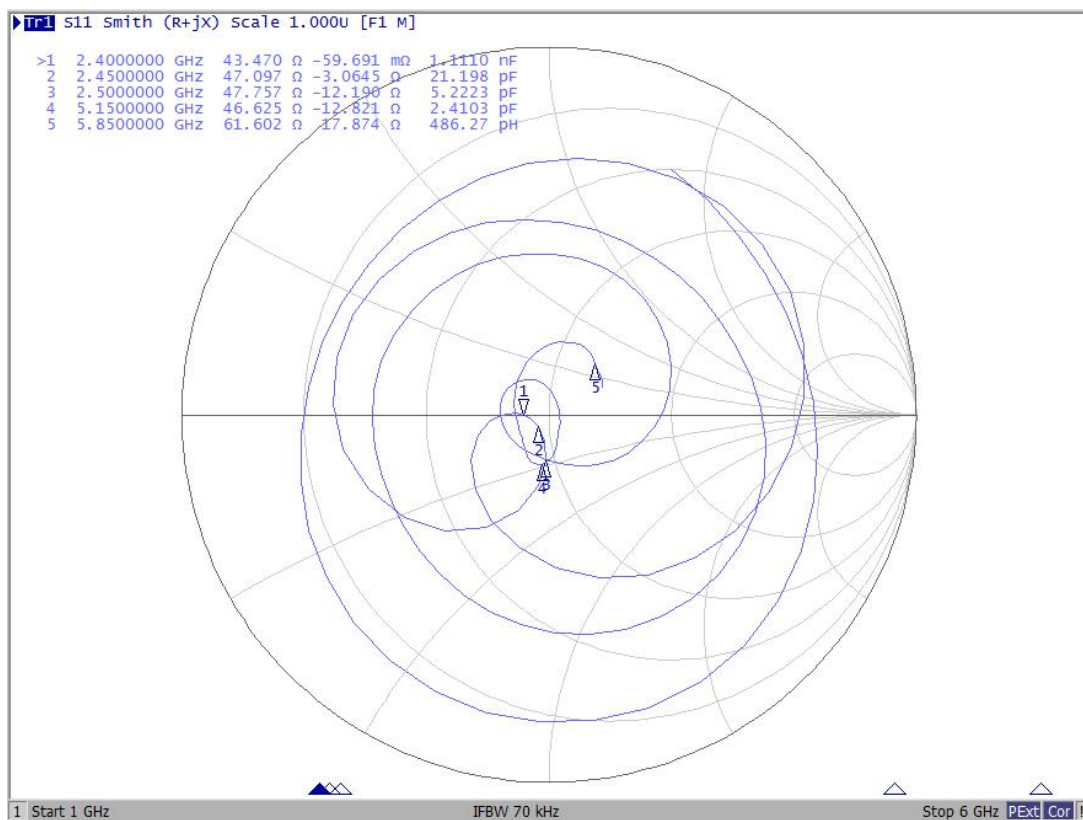

3-3 Matching circuit

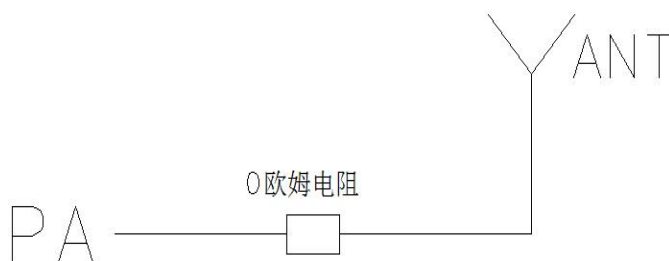

3-4 No-source test data

Frequency (MHz)	2400	2450	2500	5150	5850
Average Gain	1.42	1.72	1.65	2.34	2.57
Efficiency (dB)	(44%)	(48%)	(45%)	(61%)	(66%)

ANTENNA SPECIFICATION

CUS P/N :WF7D-20-White WIFI 天线组件
ZTX P/N :WF7D-20-White WIFI 天线组件

ApplicationDate:Jan.22,2021
Editor:

Rev: R:A1
Page 6 of 12

3-5 Directional drawing of horizontal plane of H

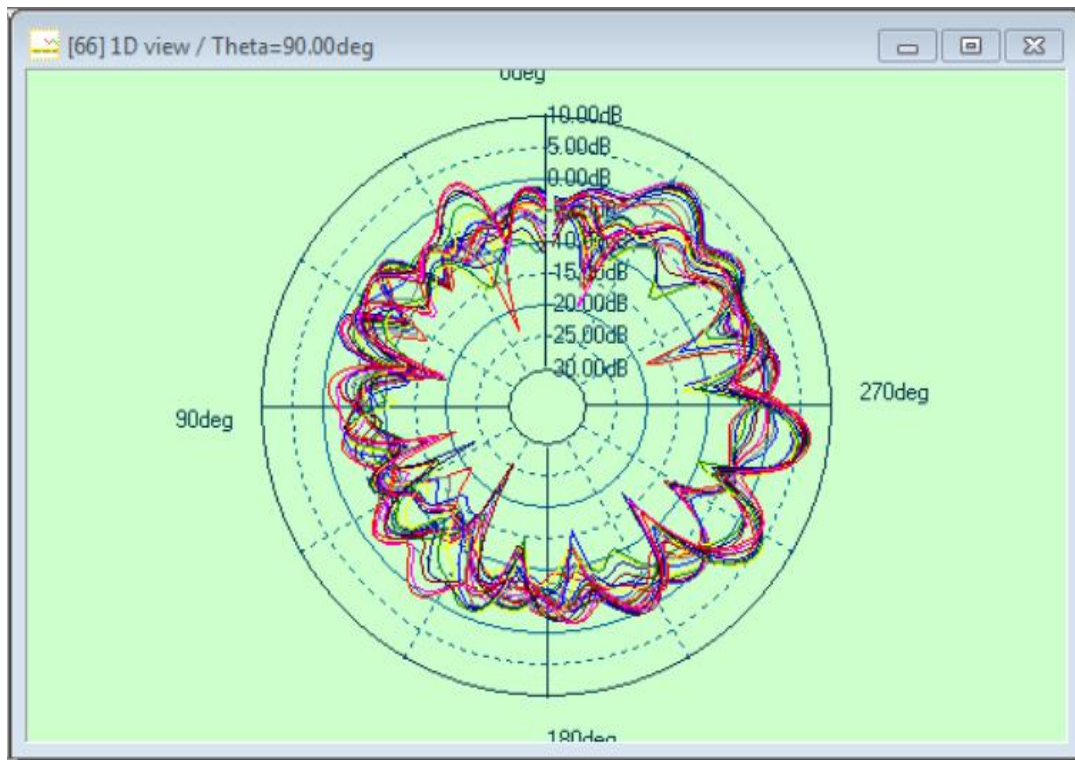

E1

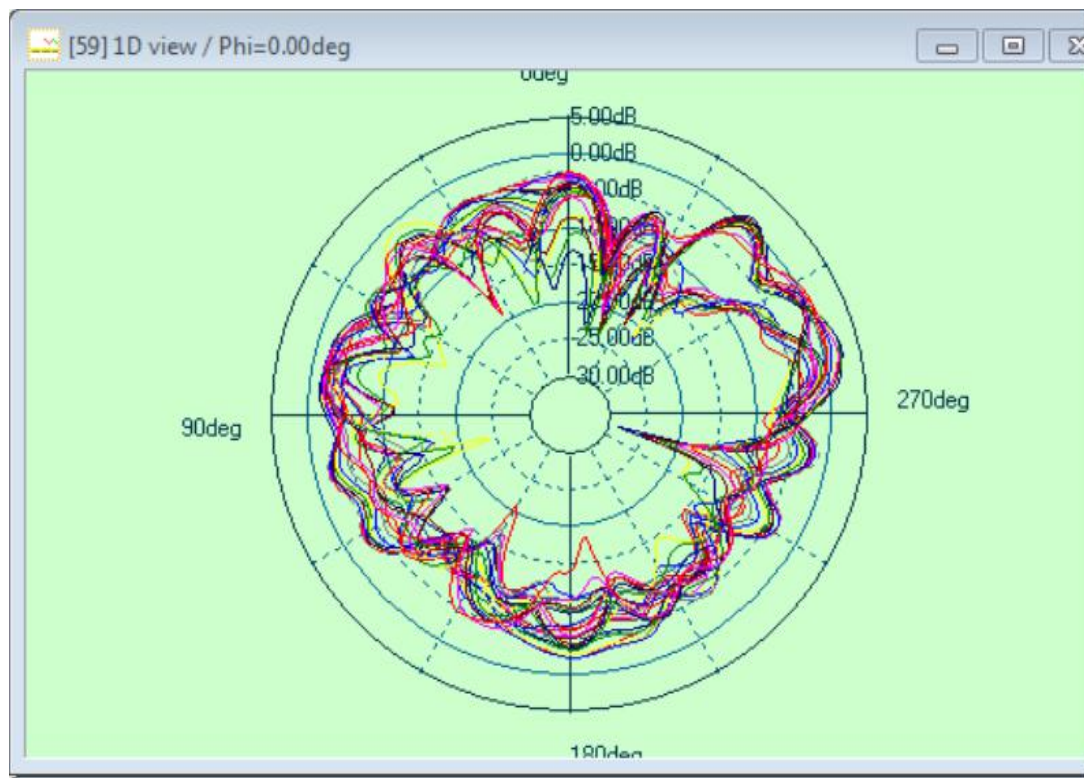

E2

ANTENNA SPECIFICATION

CUS P/N :WF7D-20-White WIFI 天线组件
ZTX P/N :WF7D-20-White WIFI 天线组件

ApplicationDate:Jan.22,2021
Editor:

Rev: R:A1
Page 7 of 12

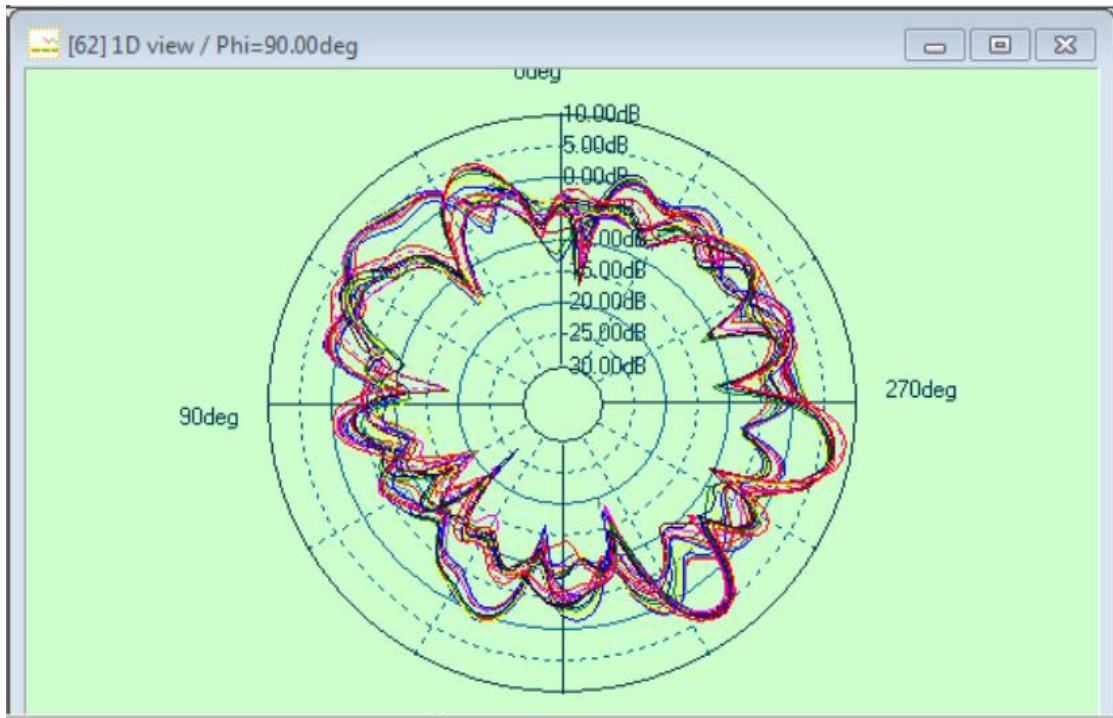

3-6 3D radiation drawing

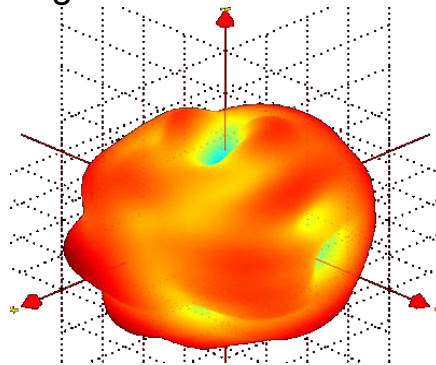

3-7 产品实物图片



ANTENNA SPECIFICATION

CUS P/N :WF7D-20-White WIFI 天线组件
ZTX P/N :WF7D-20-White WIFI 天线组件

ApplicationDate:Jan.22,2021
Editor:

Rev: R:A1
Page 8 of 12

4. Mechanical Specification

4-1 Mechanical Configuration(WIFI)

版本	说明	审核	日期	批准	日期

展开图

粉红色线为折弯线

立体图

MATTER	RoHS (PPM)
Cd	≤100
Pb	≤1000
Hg	≤1000
Cr6+	≤1000
PBB	≤1000
PBDE	≤1000

备注:

1. 角度尺寸模具设计时依图纸尺寸作参照, 样品及量产实配即可;
2. 打"*"为严格控制尺寸 (IQC必测等级A) ;
3. 字符说明 (采用宋体, 要求字迹清晰, 弹片无变形) ;
4. 产品不能有油污、毛刺、利边、缺料、变形、压印过深等不良;
5. 需通过48小时盐雾测试;
6. 包装时需用吸塑盒摆放整齐, 运输过程中产品不能挤压碰撞等;
7. 未经过ZTX公司确认, 材料不能随意更改;

宋注明公差	5 UND	±0.08	10-10	±0.10	35-50	±0.15	50-100	±0.18	100 OVE	±0.20	
制图	龙秋霖	日期	2017.05.18	审核	吴明运	日期	2017.05.18	批准	龙秋霖	日期	2017.05.18
制图	龙秋霖	日期	2017.05.18	审核	吴明运	日期	2017.05.18	批准	龙秋霖	日期	2017.05.18
单位	mm	比例	1:1	材料	SUS304	厚度	±0.20mm (镀锌)	产品名称	WF7D (WIFI)	图号	ZTX-Q08-RD-018
物料	1.01.00350	数量	1/1	规格	WF7D (WIFI)	图号	ZTX-Q08-RD-018	版本	1.0	日期	2017.05.18

ANTENNA SPECIFICATION

CUS P/N :WF7D-20-White WIFI 天线组件
ZTX P/N :WF7D-20-White WIFI 天线组件

ApplicationDate:Jan.22,2021
Editor:

Rev: R:A1
Page 9 of 12

4-2 Mechanical Configuration(天线组件)

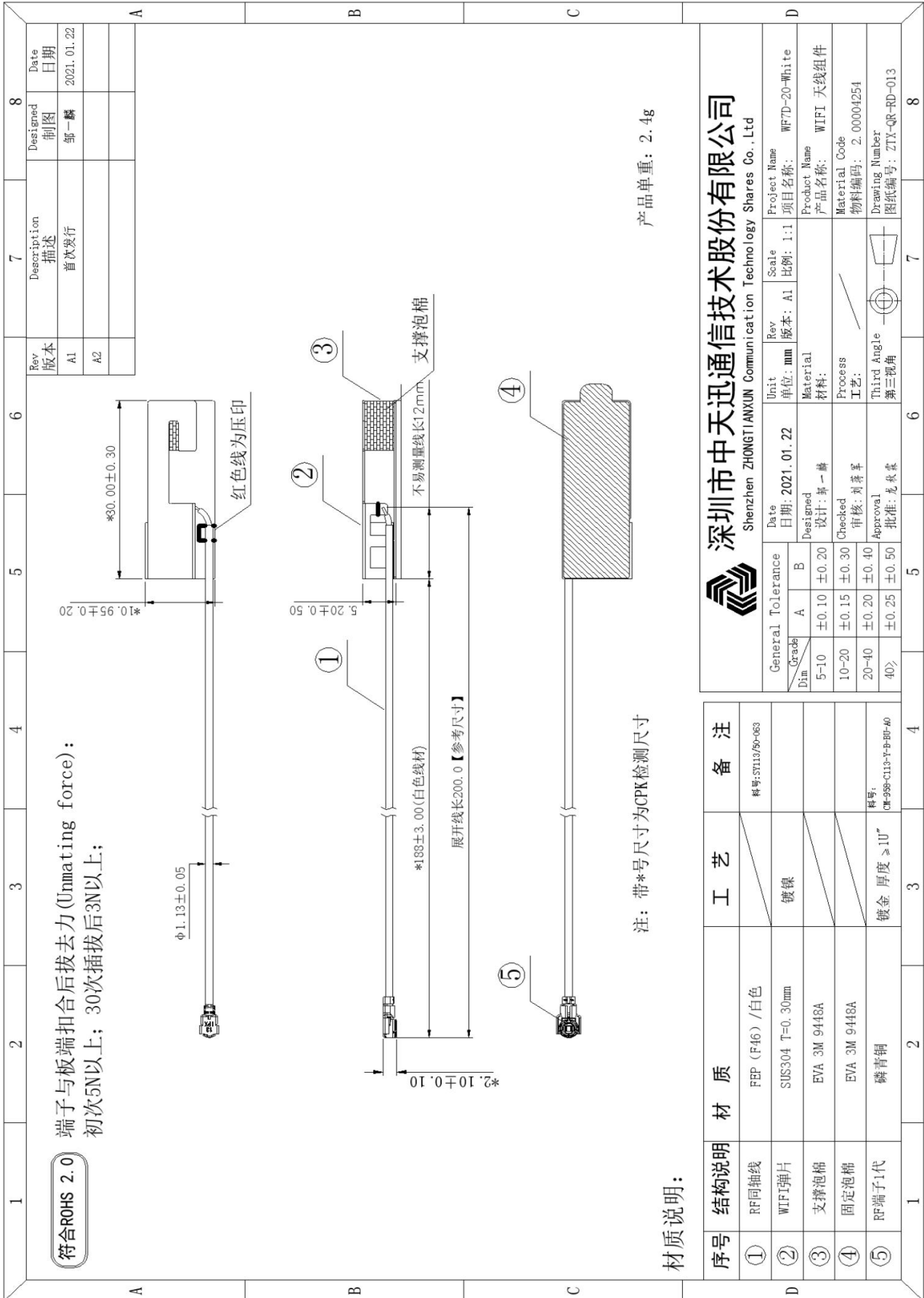

ANTENNA SPECIFICATION

CUS P/N :WF7D-20-White WIFI 天线组件

ApplicationDate:Jan.22,2021

Rev: R:A1

ZTX P/N :WF7D-20-White WIFI 天线组件

Editor:

Page 10 of 12

5. Environment Characteristic

NO.	ITEM	TEST CONDITION	SPECIFICATION
5-1	High Temperature/Humidity Storage Test(non operating)	1.Temperature: +80 ±2°C 2.Humidity: 90~95%RH 3.Time: 48hrs	No material deformation is allowed.
5-2	Low Temperature/Humidity Storage Test(non operating)	1.Temperature: -30±2°C 2.Humidity: 0%RH 3.Time:48hrs	The VSWR, Gain, Radiation Pattern must be met specifications after these test.







ANTENNA SPECIFICATION

CUS P/N :WF7D-20-White WIFI 天线组件
ZTX P/N :WF7D-20-White WIFI 天线组件

ApplicationDate:Jan.22,2021
Editor:

Rev: R:A1
Page 11 of 12

6.The packing way

产品名称	产品型号	文件编号	版本	工序序号/名称	工序工时	日产量																								
WIFI天线	WF7D-20-White	ZTX-QD-WI-	A1	包装/装箱	/	/																								
<p>包装规范</p> <p>作业方法（自检验该工序作业合格后，方能流入下一道工序）</p> <ol style="list-style-type: none"> 每40pcs产品盘旋缠绕，用PE开口胶袋包装，贴小标签，填写产品名称、物料号、数量、周期等信息； 将独立包装好的产品，每9袋（360PCS）装入（36*28cm）PE封口胶袋中，贴标签，填写产品名称、物料号、数量、周期等信息； 装箱，纸箱规格（38*26*9cm）每小箱装2袋（720pcs）； 装箱，纸箱规格（45*32.5*42cm）每大箱装5小箱（3600pcs）尾数除外； 外箱的右上角贴产品票，标签内容包括（物料名称，Box ID, 物料编码，数量，生产日期，供应名称，供应商代码，原产地，批次/Bin值，条码等）不可有漏写，写错现象； 箱子用胶纸以“工”字型封箱。 																														
<p>注意事项：</p> <p>注意标签有无贴错，漏贴，箱子有无破损； 物料标签内容按TPV要求。</p>																														
 <p>图1：确认数量/橡皮筋包扎/贴标签</p>																														
 <p>图2：装袋/贴标签</p>																														
 <p>图3：装箱/贴标签</p>																														
 <p>图4：贴产品票/封箱</p>																														
<table border="1"> <thead> <tr> <th>物料名称</th> <th>物料编码</th> <th>用量</th> <th>使用工具</th> </tr> </thead> <tbody> <tr> <td>PE开口袋</td> <td></td> <td>90</td> <td>240*160mm</td> </tr> <tr> <td>PE封口袋</td> <td></td> <td>10</td> <td>360*280mm</td> </tr> <tr> <td>橡皮筋</td> <td></td> <td>90</td> <td></td> </tr> <tr> <td>纸箱</td> <td></td> <td>5</td> <td>38*26*9cm</td> </tr> <tr> <td>纸箱</td> <td></td> <td>1</td> <td>45*32.5*42cm</td> </tr> </tbody> </table>							物料名称	物料编码	用量	使用工具	PE开口袋		90	240*160mm	PE封口袋		10	360*280mm	橡皮筋		90		纸箱		5	38*26*9cm	纸箱		1	45*32.5*42cm
物料名称	物料编码	用量	使用工具																											
PE开口袋		90	240*160mm																											
PE封口袋		10	360*280mm																											
橡皮筋		90																												
纸箱		5	38*26*9cm																											
纸箱		1	45*32.5*42cm																											
<p>小标签/条码标</p>																														
<p>修订内容</p>																														
版本	新制定																													
A1	审核	易爱玲	品质确认	胡春梅	修订日期	修订人																								
制订	陈章文				2021/1/22	陈章文																								
				批准		龙秋霖																								

ANTENNA SPECIFICATION

CUS P/N :WF7D-20-White WIFI 天线组件
ZTX P/N :WF7D-20-White WIFI 天线组件

ApplicationDate:Jan.22,2021
Editor:

Rev: R:A1
Page 12 of 12

附页： 出货标签模板

名称: WIFI天线 (Name):WIFI antenna		
型号: WF7D-20-White (Type)	客户代码: 368GAAWA727GSD (Customers No.)	
数量: 3600 PCS (Qty)	批号: ZTX2021012204 (Production No.)	ROHS
合同号: (Contract No.)	箱号: (No.)	
惠州高盛达科技有限公司 (HUIZHOU GAOSHENGDA TECHNOLOGY CO.,LTD.) Made in china		



PN: G. 5. 13. WF7DX10AGD LOT NO: 1205-2012010019		Date Code: 210122 VENDOR: ZTX
REEL NO: 201004421012299005 PART DESC: WF7D-20-White		
QTY: 3600		
深圳市中天迅通信技术股份有限公司		

名称: WIFI天线 (Name):WIFI antenna		
型号: WF7D-20-White (Type)	客户代码: 368GAAWA727GSD (Customers No.)	
数量: 720 PCS (Qty)	批号: ZTX2021012204 (Production No.)	ROHS
合同号: (Contract No.)	箱号: (No.)	
惠州高盛达科技有限公司 (HUIZHOU GAOSHENGDA TECHNOLOGY CO.,LTD.) Made in china		



368GAAWA727GSD WF7D-20-White/PIFA/2.4G+5G/ 外拉/200mm/720pcs/TPV/白色 QTY: 360 PCS 20210122 Made in china	A1
--	----



368GAAWA727GSD WF7D-20-White/PIFA/2.4G+5G/ 外拉/200mm/720pcs/TPV/白色 QTY: 40 PCS 20210122 Made in china	A1
---	----

