

ZDGF7668AU-C User Manual

Product Name : IEEE 802.11 a/b/g/n/ac 2.4GHz+5GHz 2T2R, Bluetooth 5.0
USB Module

Model : ZDGF7668AU-C

1. Introduction

Thank you for using the Wi-Fi module product provided by Qingdao Intelligent & Precise Electronics Co., Ltd. Before use, please read this user manual carefully. Please follow the technical specifications when using the module in your design and develop activities. Qingdao Intelligent & Precise Electronics Co., Ltd has the right to change the contents of this manual in accordance with the needs of the technical development.

FCC & IC application:

This device complies with Part 15 of the FCC Rules / Industry Canada licence-exempt RSS standard(s). Operation is subject to the following two conditions: (1) this device may not cause harmful interference, and (2) this device must accept any interference received, including interference that may cause undesired operation.

Le présent appareil est conforme aux CNR d'Industrie Canada applicables aux appareils radio exempts de licence. L'exploitation est autorisée aux deux conditions suivantes : (1) l'appareil ne doit pas produire de brouillage, et (2) l'utilisateur de l'appareil doit accepter tout brouillage radioélectrique subi, même si le brouillage est susceptible d'en compromettre le fonctionnement.

The device for operation in the band 5150-5250 MHz is only for indoor use to reduce the potential for harmful interference to co-channel mobile satellite systems.

Les dispositifs fonctionnant dans la bande de 5 150 à 5 250 MHz sont réservés uniquement pour une utilisation à l'intérieur afin de réduire les risques de brouillage préjudiciable aux systèmes de satellites mobiles utilisant les mêmes canaux.

Changes or modifications not expressly approved by the party responsible for compliance could void the user's authority to operate the equipment.

This equipment has been tested and found to comply with the limits for a Class B digital device, pursuant to part 15 of the FCC Rules. These limits are designed to provide reasonable protection against harmful interference in a residential installation. This equipment generates uses and can radiate radio frequency energy and, if not installed and used in accordance with the instructions, may cause harmful interference to radio communications. However, there is no guarantee that interference will not occur in a particular installation. If this equipment does cause harmful interference to radio or television reception, which can be determined by turning the equipment off and on, the user is encouraged to try to correct the interference by one or more of the following measures:

- Reorient or relocate the receiving antenna.
- Increase the separation between the equipment and receiver.
- Connect the equipment into an outlet on a circuit different from that to which the receiver is connected.
- Consult the dealer or an experienced radio/TV technician for help.

MPE Requirements

To satisfy FCC / IC RF exposure requirements, a separation distance of 20 cm or more should be maintained between the antenna of this device and persons during device operation.

To ensure compliance, operations at closer than this distance is not recommended.

Les antennes installées doivent être situées de façon à ce que la population ne puisse y être exposée à une distance de moins de 20 cm. Installer les antennes de façon à ce que le personnel ne puisse approcher à 20 cm ou moins de la position centrale de l'antenne.

La FCC des États-Unis stipule que cet appareil doit être en tout temps éloigné d'au moins 20 cm des personnes pendant son fonctionnement.

Region Selection

Limited by local law regulations, version for North America does not have region selection option.

Label

Host labeling requirement: Contains transmitter module FCC ID: 2AJVQ-7668AUC".

Host labeling requirement: Contains transmitter module IC: 22470- 7668AUC".

2. Product Information

2.1 Product Information

ZDGF7668AU-C Wi-Fi USB module is a wireless signal module device work at 2.4GHz (2.400 ~ 2.4835GHz)/5GHz (5.150 ~ 5.85GHz). ZDGF7668AU-C comply with IEEE 802.11a、802.11b、802.11 g、802.11 n and 802.11 ac standard. It supports up to 867Mbps physical layer transmitting rate. ZDGF7668AU-C support USB 2.0, which has up to 480Mbps data rate. ZDGF7668AU-C also support Bluetooth specification 2.1+EDR、 Bluetooth 4.2 Low Energy and Bluetooth 5.0.

ZDGF7668AU-C has 2T2R structure, has two onboard PIFA Antenna. It could provide stable wireless link with high throughput.

ZDGF7668AU-C is a wireless signal module. It could transmit and receive Wi-Fi wireless signal device without radar detection. It is widely used to multi-media device, such as smart TV. Equipped with ZDGF7668AU-C, a smart TV could access to Wireless Local Network, which is also called WLAN or WIFI network. ZDGF7668AU-C helps multi-media device achieve to send & receive data package in a wireless way.

2.2 Feature

- IEEE standard: IEEE 802.11a/b/g/n/ac client device without radar detection
- Bluetooth 5.0
- operating Frequency 2.4GHz/5 GHz

- support up to 867Mbps
- 2T2R mode
- Support 20MHz, 40MHz, 80MHz in 5GHz band, and 20MHz, 40MHz band width in 2.4GHz band.
- support USB 2.0 high data rate mode,10-pin interface
- support WFA/ WPA/WPA2 /WPS2.0/WAPI security
- RoH
- MAC /baseband/RF: MT7668AU

3. Product Specification

3.1 Parameter

WLAN Standard	IEEE802.11a/b/g/n/ac
Data Interface	USB2.0
WLAN Modulation Mode	WIFI: 802.11b: CCK, DQPSK, DBPSK 802.11a, 802.11g: 64QAM, 16QAM, QPSK, BPSK 802.11n: 64QAM, 16QAM, QPSK, BPSK 802.11ac: 256QAM, 64QAM, 16QAM, QPSK, BPSK
WLAN Working Frequency	2.4G: 2400-2483.5MHz; 5G: 5150-5350MHz, 5470-5850MHz.
WLAN Receiver Sensitivity	11b @ 11Mbps: (Max.): -84dBm, (Typical): -87dBm (PER<8%) 11g @ 54Mbps: (Max.): -69dBm, (Typical): -77dBm (PER<10%) 11n @ MCS7 (2.4g HT20): (Max.): -67dBm, (Typical): -73dBm (PER<10%) 11n @ MCS7 (2.4g HT40): (Max.): -64dBm, (Typical): -68dBm (PER<10%) 11a @ 54Mbps: (5g): -69dBm, (Typical): -77dBm (PER<10%) 11n @ MCS7 (5g HT20): (Max.): -67dBm, (Typical): -73dBm (PER<10%) 11n @ MCS7 (5g HT40): (Max.): -64dBm, (Typical): --69dBm (PER<10%) 11ac @ MCS9 (5g HT80): (Max.): -51dBm, (Typical): -58dBm (PER<10%)
WLAN Antenna type	Two onboard PIFA antennas
WLAN Antenna Gain	2.4G: Ant0:1.91dBi (MAX), Ant1:1.31dBi (MAX) 5G: Ant0:3.52dBi (MAX), Ant1:3.44dBi (MAX)
BT Standard	BT 2.1+EDR, BT 3.0+HS, BT 4.2 BLE, BT5.0
BT Working Frequency	2400-2483.5MHz
BT Modulation Mode	GFSK, $\pi/4$ -DQPSK, 8-DPSK
BT Antenna Gain	0.13dBi (MAX)
Working Voltage	5V \pm 10% I/O supply voltage
Working Temperature	-10~+70°C
Storage Temperature	-40~+125°C

4. Hardware information

4.1 structure dimension (Unit: mm)

PCB Material: FR-4, Surface treatment: OSP.

Appearance Dimension (mm): 70 (+/- 0.3)×45(+/- 0.3)

PCB thickness: 1.6mm (+/-0.15mm).

Antenna Height: 10.0mm (+/-0.15mm).

4.2 PIN definition

序号	定义	用法
1	VCC	VCC
2	VCC	VCC
3	GND	GND
4	USBDM	USB D-
5	NC	NC
6	USBDP	USB D+
7	WIFI_DEV_WAKE	WIFI Wake Up Host
8	GND	GND
9	WIFI_REG_ON	DCDC enable
10	RST	reset

4.3 Block Diagram

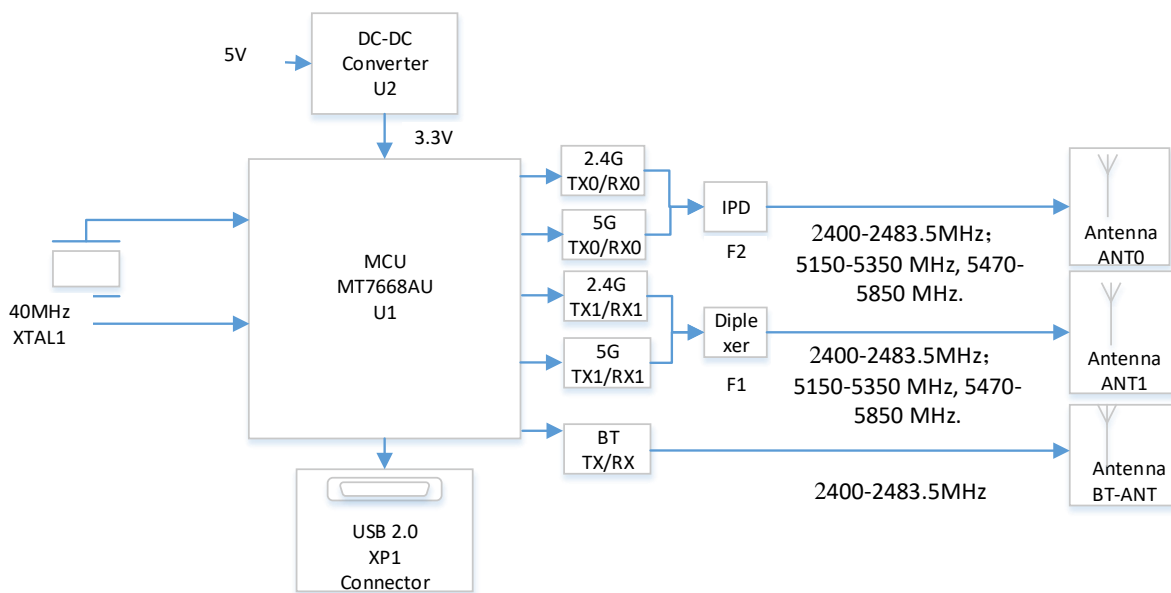

BLOCK DIAGRAM

5 EU single contact point

Hisense Czech (Manufacture) s.r.o.

U Nové Hospody 1164/4, 301 00 Plzeň , Czech Republic.

6 Manufacturer's postal address

No.218, Qianwangang Road, Qingdao Economic & Technological Development Zone, Shandong, China

7 Importer's name & address

Hisense Czech (Manufacture) s.r.o.

U Nové Hospody 1164/4, 301 00 Plzeň, Czech Republic.

8. The requirement for KDB 996369 D03:

8.1 List of applicable FCC rules

FCC Part 15. 247 and FCC Part 15.407.

8.2 Summarize the specific operational use conditions

None

8.3 Limited module procedures

The module is a single module, so this requirement is not applicable to the product.

8.4 Trace antenna designs

The module uses the permanent PIFA antenna, so this requirement is not applicable to the product.

8.5 RF exposure considerations

The host device manufacturer should confirm that a separation distance of 20 cm or more should be maintained between the antenna of this host device and persons during the host device operation.

8.6 Antennas

For Bluetooth: PIFA antenna, 0.13dBi

For 2.4G wifi: Ant0: 1.91dBi, Ant1: 1.31dBi

5G wifi: Ant0: 3.52dBi, Ant1:3.44dBi

8.7 Label and compliance information

If this certified module is installed inside the host device, then the outside of the host must be labeled with "Contains FCC ID: 2AJVQ-7668AUC and IC: 22470- 7668AUC".

8.8 Information on test modes and additional testing requirements

The host manufacturer can use the software of Combo Tool to make the Bluetooth transmit continuously, and the software of QA Tool to make the wifi transmit continuously.

8.9 Additional testing, Part 15 Subpart B disclaimer

The module only complies with the FCC Part 15.247 and FCC 15.407. If the module is installed in the host device, the host manufacturer is responsible for the compliance to any other FCC rules that apply to the host not covered by the modular transmitter grant of certification. For example, if the host manufacturer markets their product as being Part 15 Subpart B compliant (when it also contains unintentional-radiator digital circuitry), then the host manufacturer shall provide a notice stating that the final host product still requires Part 15 Subpart B compliance testing with the modular transmitter installed.