

S

T

S

L

A

B



## FCC TEST REPORT

Report No:STS1712021W01

Issued for

MEAZON ELECTRONIC SYSTEMS S.A.

N.E.O PATRON ATHINON 57, 26442, PATRA, Greece

<b>Product Name:</b>	JANUS GATEWAY
<b>Brand Name:</b>	MEAZON
<b>Model Name:</b>	JANUS GATEWAY
<b>Series Model:</b>	N/A
<b>FCC ID:</b>	2AJUUJG
<b>Test Standard:</b>	FCC Part 15.249

Any reproduction of this document must be done in full. No single part of this document may be reproduced without permission from STS, All Test Data Presented in this report is only applicable to presented Test sample.

Shenzhen STS Test Services Co., Ltd.  
1/F., Building B, Zhuoke Science Park, No.190,Chongqing Road,  
Fuyong Street, Bao'an District, Shenzhen, Guangdong,China  
TEL: +86-755 3688 6288 FAX: +86-755 3688 6277 E-mail:sts@stsapp.com





TEST RESULT CERTIFICATION

Applicant's name : MEAZON ELECTRONIC SYSTEMS S.A.
Address : N.E.O PATRON ATHINON 57, 26442, PATRA, Greece
Manufacture's Name : MEAZON ELECTRONIC SYSTEMS S.A.
Address : N.E.O PATRON ATHINON 57, 26442, PATRA, Greece

Product description

Product Name .....: JANUS GATEWAY
Brand Name .....: MEAZON
Model Name.....: JANUS GATEWAY
Series Model .....: N/A
Test Standards.....: FCC Part15.249

Test procedure : ANSI C63.4-2014 and ANSI C63.10-2013

This device described above has been tested by STS, and the test results show that the equipment under test (EUT) is in compliance with the FCC requirements. And it is applicable only to the tested sample identified in the report.

This report shall not be reproduced except in full, without the written approval of STS, this document may be altered or revised by STS, personal only, and shall be noted in the revision of the document.

Date of Test :
Date of performance of tests : 06 Dec. 2017 ~20 Dec. 2017
Date of Issue : 21 Dec. 2017
Test Result : Pass

Testing Engineer : Sean She
(Sean she)

Technical Manager : Hakim.hou
(Hakim.hou)

Authorized Signatory : Vita Li
(Vita Li)





Table of Contents	Page
<b>1. SUMMARY OF TEST RESULTS</b>	<b>5</b>
1.1 TEST FACTORY	6
1.2 MEASUREMENT UNCERTAINTY	6
<b>2. GENERAL INFORMATION</b>	<b>7</b>
2.1 GENERAL DESCRIPTION OF EUT	7
2.2 DESCRIPTION OF TEST MODES	8
2.3 BLOCK DIGRAM SHOWING THE CONFIGURATION OF SYSTEM TESTED	9
2.4 DESCRIPTION OF SUPPORT UNITS	10
2.5 EQUIPMENTS LIST FOR ALL TEST ITEMS	11
<b>3. EMC EMISSION TEST</b>	<b>12</b>
3.1 CONDUCTED EMISSION MEASUREMENT	12
3.2 RADIATED EMISSION MEASUREMENT	16
<b>4. BANDWIDTH TEST</b>	<b>28</b>
4.1 TEST PROCEDURE	28
4.2 TEST SETUP	28
4.3 EUT OPERATION CONDITIONS	28
4.4 TEST RESULTS	28
<b>5. ANTENNA REQUIREMENT</b>	<b>30</b>
5.1 STANDARD REQUIREMENT	30
5.2 EUT ANTENNA	30
<b>APPENDIX I- PHOTOS OF TEST SETUP</b>	<b>31</b>



**Revision History**

Rev.	Issue Date	Report NO.	Effect Page	Contents
00	21 Dec. 2017	STS1712021W01	ALL	Initial Issue





## 1. SUMMARY OF TEST RESULTS

Test procedures according to the technical standards:

FCC Part 15.249,Subpart C			
Standard Section	Test Item	Judgment	Remark
15.207	Conducted Emission	Pass	
15.203	Antenna Requirement	Pass	
15.249	Radiated Emission	Pass	
15.249	20dB Bandwidth	Pass	

### NOTE:

(1) "N/A" denotes test is not applicable in this Test Report

(2) All tests are according to ANSI C63.4-2014 and ANSI C63.10-2013

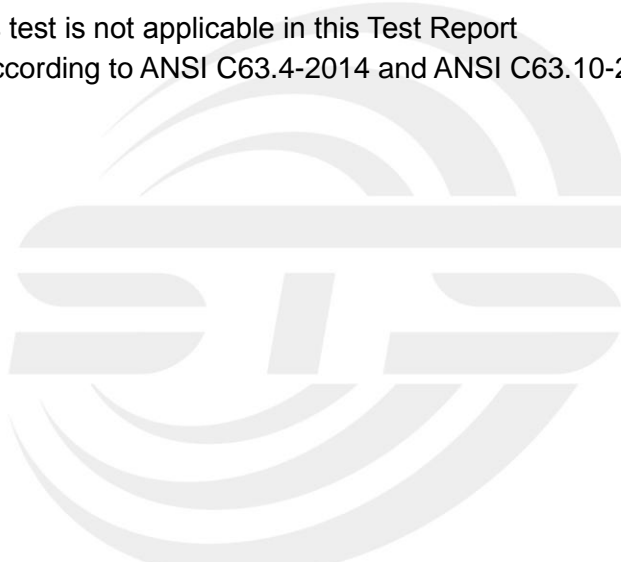



### 1.1 TEST FACTORY

Shenzhen STS Test Services Co., Ltd.

Add. : 1/F., Building B, Zhuoke Science Park, No.190, Chongqing Road,  
Fuyong Street, Bao'an District, Shenzhen, Guangdong, China

CNAS Registration No.: L7649; FCC Registration No.: 625569

IC Registration No.: 12108A; A2LA Certificate No.: 4338.01;

### 1.2 MEASUREMENT UNCERTAINTY

The reported uncertainty of measurement  $y \pm U$ , where expanded uncertainty  $U$  is based on a standard uncertainty multiplied by a coverage factor of  $k=2$ , providing a level of confidence of approximately **95 %**.

No.	Item	Uncertainty
1	Conducted Emission (9KHz-150KHz)	$\pm 2.88$ dB
2	Conducted Emission (150KHz-30MHz)	$\pm 2.67$ dB
3	RF power,conducted	$\pm 0.71$ dB
4	Spurious emissions,conducted	$\pm 0.63$ dB
5	All emissions,radiated (9KHz-30MHz)	$\pm 3.02$ dB
6	All emissions,radiated (30MHz-200MHz)	$\pm 3.80$ dB
7	All emissions,radiated (200MHz-1000MHz)	$\pm 3.97$ dB



## 2. GENERAL INFORMATION

### 2.1 GENERAL DESCRIPTION OF EUT

Product Name	JANUS GATEWAY
Trade Name	MEAZON
Model Name	JANUS GATEWAY
Series Model	N/A
Model Difference	N/A
Product Description	The EUT is a JANUS GATEWAY
	Operation Frequency: 920.6-923.4MHz
	Modulation Type: 2-GFSK
	Antenna Designation: Dipole Antenna
	Antenna Gain(Peak) 2 dBi
	Based on the application, features, or specification exhibited in User's Manual, the EUT is considered as an ITE/Computing Device. More details of EUT technical specification, please refer to the User's Manual.
Channel List	Please refer to the Note 2.
Adapter	Input: AC100-240V, 0.4A, 50/60 Hz Output: DC5V, 2A
Hardware Version	HW V1.2
Software Version	1402000E

Note:

1. For a more detailed features description, please refer to the manufacturer's specifications or the User's Manual.



2.

Channel	Frequency (MHz)
01	920.6
02	922
03	923.4

3. Table for Filed Antenna

Ant	Brand	Model Name	Antenna Type	Connector	Gain (dBi)	NOTE
1	MEAZON	JANUS GATEWAY	Dipole Antenna	NA	2	Antenna

The EUT antenna is spring loaded Antenna. No antenna other than that furnished by the responsible party shall be used with the device.

## 2.2 DESCRIPTION OF TEST MODES

For conducted test items and radiated spurious emissions  
Each of these EUT operation mode(s) or test configuration mode(s) mentioned below was evaluated respectively..

Worst Mode	Description	Data/Modulation
Mode 1	TX CH01	2 MHz/GFSK
Mode 2	TX CH02	2 MHz/GFSK
Mode 3	TX CH03	2 MHz/GFSK

Note:

- (1) All above mode have been measurement, only worst data was reported.
- (2) New Battery is used during all test.
- (3) We have be tested for all avaiable U.S. voltage and frequencies(For 120V,50/60Hz and 240V, 50/60Hz) for which the device is capable of operation, and the worst case of 120V,50/60Hz is shown in the report
- (4) The EUT was programmed to be in continuously transmitting mode and the transmit duty cycle is not less than 98%.



### 2.3 BLOCK DIGRAM SHOWING THE CONFIGURATION OF SYSTEM TESTED

During testing channel & power controlling software provided by the customer was used to control the operating channel as well as the output power level. The RF output power selection is for the setting of RF output power expected by the customer and is going to be fixed on the firmware of the final end product power parameters

#### Radiated Spurious Emission Test

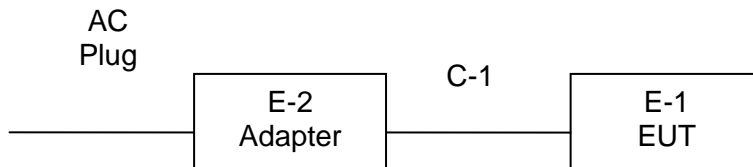

#### conduction Test Set

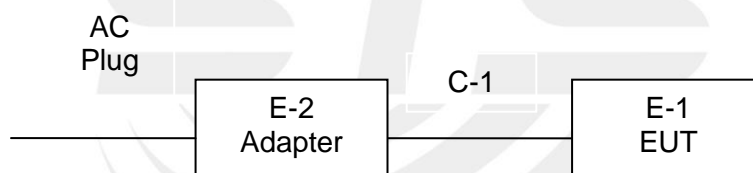

### 2.4 DESCRIPTION OF SUPPORT UNITS

The EUT has been tested as an independent unit together with other necessary accessories or support units. The following support units or accessories were used to form a representative test configuration during the tests.

Item	Equipment	Mfr/Brand	Model/Type No.	Serial No.	Note
E-2	Adapter	N/A	MX15W-0502000UX	N/A	EUT

Item	Shielded Type	Ferrite Core	Length	Note
C-1	USB Cable (FTP)	NO	100cm	EUT

Note:

- (1) The support equipment was authorized by Declaration of Confirmation.
- (2) For detachable type I/O cable should be specified the length in cm in 『Length』 column.



## 2.5 EQUIPMENTS LIST FOR ALL TEST ITEMS

## Radiation Test equipment

Kind of Equipment	Manufacturer	Type No.	Serial No.	Last calibration	Calibrated until
EMI Test Receiver	R&S	ESW	101535	2017.06.01	2018.05.31
Bilog Antenna	TESEQ	CBL6111D	34678	2017.03.24	2018.03.23
Horn Antenna	Schwarzbeck	BBHA 9120D(1201)	9120D-1343	2017.03.06	2018.03.05
Operational Manual Passive Loop (9K--30MHz)	ETS	6512	00165355	2017/03/06	2018/03/05
Pre-mpifier (0.1M-3GHz)	EM	EM330	60538	2017.03.12	2018.03.11
PreAmplifier	Agilent	8449B	60538	2017.10.15	2018.10.14
USB RF power sensor	DARE	RPR3006W	15I00041SNO0 3	2017.10.15	2018.10.14
Semi-anechoic chamber	Changling	966	N/A	2017.10.15	2018.10.14

## Conduction Test equipment

Kind of Equipment	Manufacturer	Type No.	Serial No.	Last calibration	Calibrated until
Test Receiver	R&S	ESCI	101427	2017.10.15	2018.10.14
LISN	R&S	ENV216	101242	2017.10.15	2018.10.14
conduction Cable	EM	C01	N/A	2017.03.12	2018.03.11
Temperature & Humidity	Mieo	HH660	N/A	2017.10.15	2018.10.14

### 3. EMC EMISSION TEST

#### 3.1 CONDUCTED EMISSION MEASUREMENT

##### 3.1.1 POWER LINE CONDUCTED EMISSION LIMITS

Operating frequency band. In case the emission fall within the restricted band specified on Part 15.249 limit in the table below has to be followed.

FREQUENCY (MHz)	Quasi-peak	Average
0.15 -0.5	66 - 56 *	56 - 46 *
0.50 -5.0	56.00	46.00
5.0 -30.0	60.00	50.00

Note:

- (1) The tighter limit applies at the band edges.
- (2) The limit of " \* " marked band means the limitation decreases linearly with the logarithm of the frequency in the range.

The following table is the setting of the receiver

Receiver Parameters	Setting
Attenuation	10 dB
Start Frequency	0.15 MHz
Stop Frequency	30 MHz
IF Bandwidth	9 kHz

### 3.1.2 TEST PROCEDURE

- a. The EUT was 0.8 meters from the horizontal ground plane and 0.4 meters from the vertical ground plane with EUT being connected to the power mains through a line impedance stabilization network (LISN). All other support equipments powered from additional LISN(s). The LISN provide 50 Ohm/ 50uH of coupling impedance for the measuring instrument.
- b. Interconnecting cables that hang closer than 40 cm to the ground plane shall be folded back and forth in the center forming a bundle 30 to 40 cm long.
- c. I/O cables that are not connected to a peripheral shall be bundled in the center. The end of the cable may be terminated, if required, using the correct terminating impedance. The overall length shall not exceed 1 m.
- d. LISN at least 80 cm from nearest part of EUT chassis.
- e. For the actual test configuration, please refer to the related Item –EUT Test Photos.

### 3.1.3 TEST SETUP

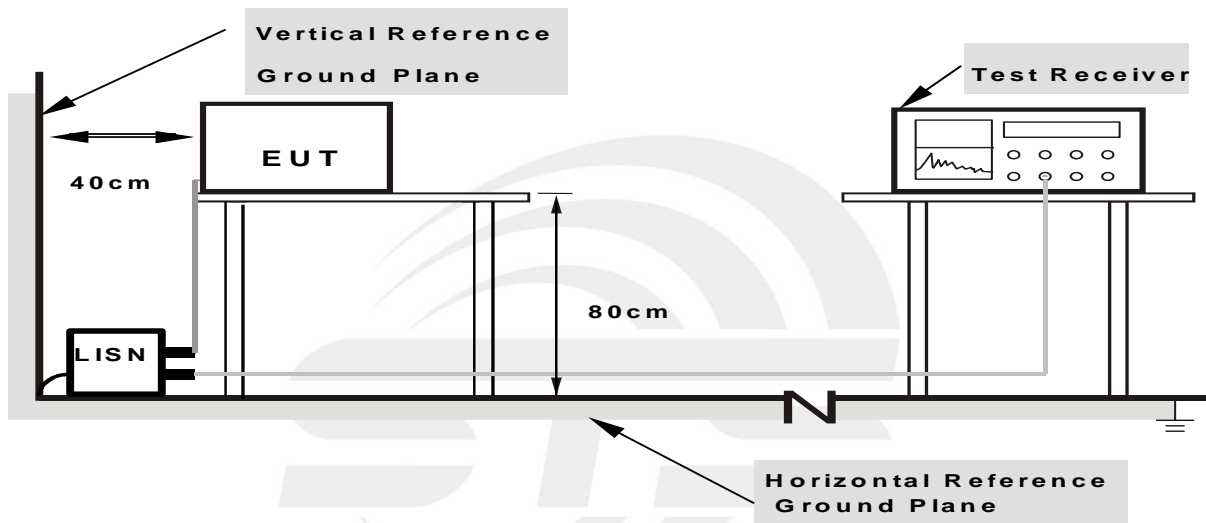

- Note: 1.Support units were connected to second LISN.**  
**2.Both of LISNs (AMN) are 80 cm from EUT and at least 80 cm from other units and other metal planes**

### 3.1.4 EUT OPERATING CONDITIONS

The EUT was configured for testing in a typical fashion (as a customer would normally use it). The EUT has been programmed to continuously transmit during test. This operating condition was tested and used to collect the included data.



3.1.5 TEST RESULTS

Temperature:	26 °C	Relative Humidity:	60%
Pressure:	1010hPa	Phase:	L
Test Voltage:	AC 120V/60Hz	Test Mode:	Mode 1

No.	Freq. (MHz)	Reading_Level (dBuV)			Correct Factor (dB)	Measurement (dBuV)			Limit (dBuV)		Margin (dB)		P/F	Comment
		Peak	QP	AVG		Peak	QP	AVG	QP	AVG	QP	AVG		
1	0.1859	39.64		23.86	10.20	49.84		34.06	64.21	54.21	-14.37	-20.15	P	
2	0.2979	34.58		18.51	10.29	44.87		28.80	60.30	50.30	-15.43	-21.50	P	
3	0.3619	35.26		18.48	10.31	45.57		28.79	58.68	48.68	-13.11	-19.89	P	
4	0.6460	33.65		14.11	10.33	43.98		24.44	56.00	46.00	-12.02	-21.56	P	
5	1.9059	34.76		17.45	10.25	45.01		27.70	56.00	46.00	-10.99	-18.30	P	
6	4.1619	31.03		13.95	10.36	41.39		24.31	56.00	46.00	-14.61	-21.69	P	

Remark:

1. Margin = Result (Result =Reading + Factor )–Limit

80.0 dBuV

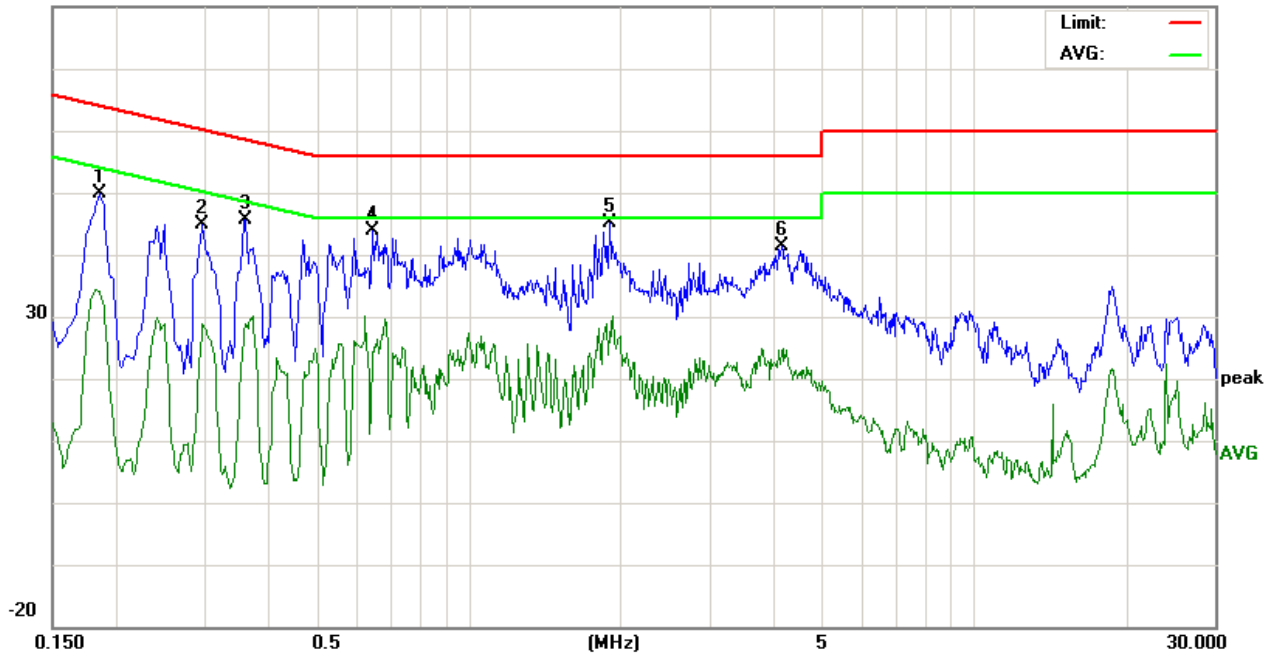



Temperature:	26 °C	Relative Humidity:	60%
Pressure:	1010hPa	Phase:	N
Test Voltage:	AC 120V/60Hz	Test Mode:	Mode 1

No.	Freq. (MHz)	Reading_Level (dBuV)			Correct Factor (dB)	Measurement (dBuV)			Limit (dBuV)		Margin (dB)		P/F	Comment
		Peak	QP	AVG		Peak	QP	AVG	QP	AVG	QP	AVG		
1	0.1739	36.52		25.22	10.19	46.71		35.41	64.77	54.77	-18.06	-19.36	P	
2	0.3579	36.61		23.71	10.31	46.92		34.02	58.78	48.78	-11.86	-14.76	P	
3	0.5939	38.19		24.60	10.32	48.51		34.92	56.00	46.00	-7.49	-11.08	P	
4	1.0100	37.99		21.79	10.37	48.36		32.16	56.00	46.00	-7.64	-13.84	P	
5	1.8500	35.49		21.02	10.27	45.76		31.29	56.00	46.00	-10.24	-14.71	P	
6	4.1738	27.98		13.65	10.35	38.33		24.00	56.00	46.00	-17.67	-22.00	P	

Remark:

1. Margin = Result (Result =Reading + Factor )–Limit

80.0 dBuV

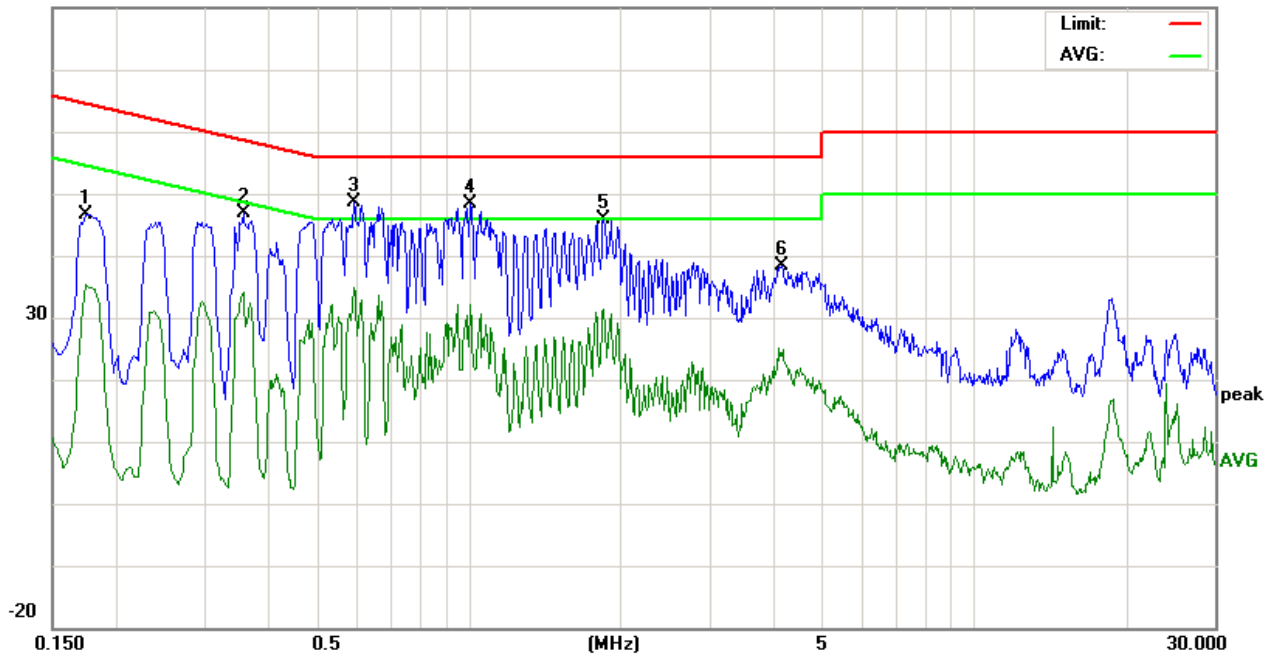



3.2 RADIATED EMISSION MEASUREMENT

3.2.1 RADIATED EMISSION LIMITS

20dBc in any 100 kHz bandwidth outside the operating frequency band. In case the emission fall within the restricted band specified on Part 15.205(a), then the Part 15.209(a) and Part 15.231(b) limit in the table below has to be followed.

LIMITS OF RADIATED EMISSION MEASUREMENT (0.009MHz - 1000MHz)

Frequencies (MHz)	Field Strength (micovolts/meter)	Measurement Distance (meters)
0.009~0.490	2400/F(KHz)	300
0.490~1.705	24000/F(KHz)	30
1.705~30.0	30	30
30~40.66	100	3
40.70~70	100	3

LIMITS OF RADIATED EMISSION MEASUREMENT ( FCC 15.249)

Frequency of Emission (MHz)	Field Strength of fundamental ((millivolts /meter)	Field Strength of Harmonics (microvolts/meter)
902-928	50	500

Notes:

- (1) Emissions radiated outside of the specified frequency bands, except for harmonics, shall be attenuated by at least 50 dB below the level of the fundamental or to the general radiated emission limits in Section 15.209, whichever is the lesser attenuation.

Spectrum Parameter	Setting
Detector	Peak
Attenuation	Auto
Start Frequency	1000 MHz
Stop Frequency	10th carrier harmonic
RB / VB (emission in restricted band)	RB>20BW,VB=20xRB

Receiver Parameter	Setting
Start ~ Stop Frequency	9kHz~90kHz / RB 200Hz for PK-AV
	90kHz~110kHz / RB 200Hz for QP
	110kHz~490KHz / RB 9kHz for PK-AV
	490kHz~30MHz / RB 9kHz for QP
	30MHz~1000MHz / RB 100kHz for QP-PK



### 3.2.2 TEST PROCEDURE

- a. The measuring distance of at 3 m shall be used for measurements at frequency up to 1GHz. For frequencies above 1GHz, any suitable measuring distance may be used.
- b. The EUT was placed on the top of a rotating table 0.8 meters above the ground at a 3 meter open area test site. The table was rotated 360 degrees to determine the position of the highest radiation.
- c. The height of the equipment or of the substitution antenna shall be 0.8 m; the height of the test antenna shall vary between 1 m to 4 m. Both horizontal and vertical polarizations of the antenna are set to make the measurement.
- d. The initial step in collecting conducted emission data is a spectrum analyzer peak detector mode pre-scanning the measurement frequency range. Significant peaks are then marked and then Quasi Peak detector mode re-measured.
- e. If the Peak Mode measured value compliance with and lower than Quasi Peak Mode Limit,
- f. For the actual test configuration, please refer to the related Item –EUT Test Photos.

Note:

Both horizontal and vertical antenna polarities were tested and performed pretest to three orthogonal axis. The worst case emissions were reported

### 3.2.3 DEVIATION FROM TEST STANDARD

No deviation



### 3.2.4 TEST SETUP

(A) Radiated Emission Test-Up Frequency Below 30MHz

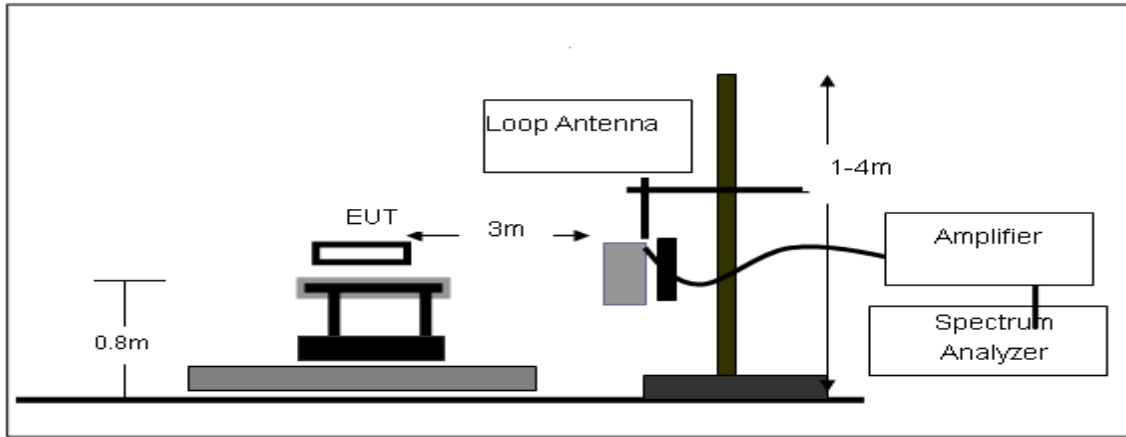

(B) Radiated Emission Test-Up Frequency 30MHz~1GHz

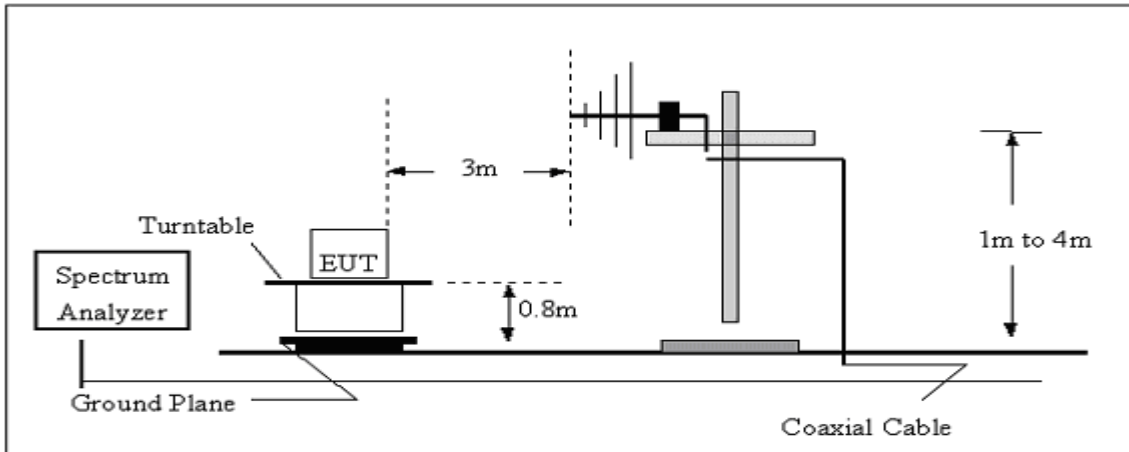

(C) Radiated Emission Test-Up Frequency Above 1GHz

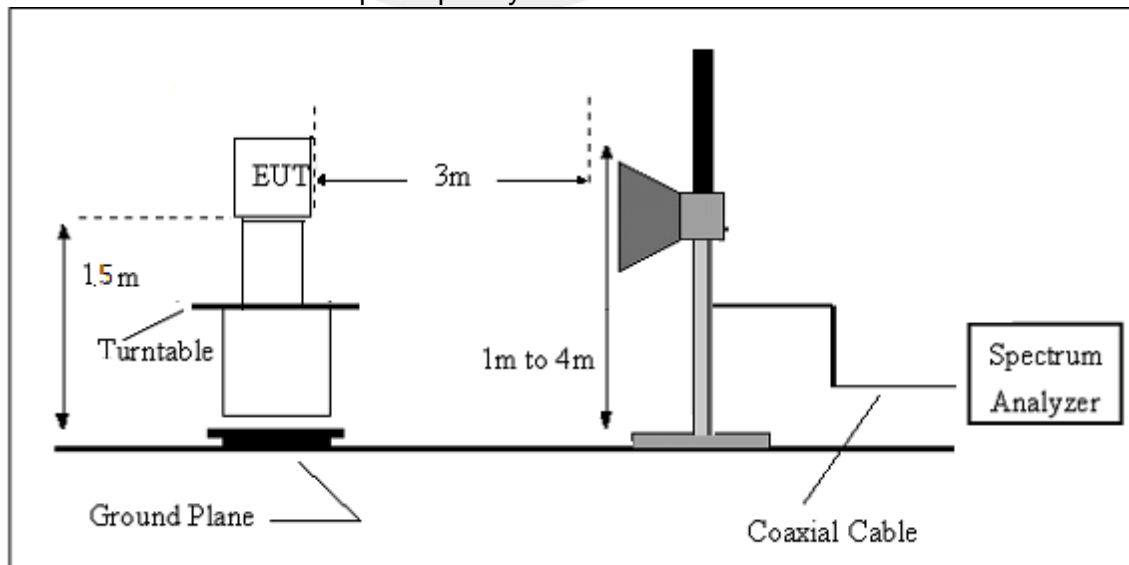



### 3.2.5 FIELD STRENGTH CALCULATION

The field strength is calculated by adding the Antenna Factor and Cable Factor and subtracting the Amplifier Gain and Duty Cycle Correction Factor (if any) from the measured reading. The basic equation with a sample calculation is as follows:

$$FS = RA + AF + CL - AG$$

Where

FS = Field Strength

CL = Cable Attenuation Factor (Cable Loss)

RA = Reading Amplitude

AG = Amplifier Gain

AF = Antenna Factor

For example

Frequency (MHz)	FS (dB $\mu$ V/m)	RA (dB $\mu$ V/m)	AF (dB)	CL (dB)	AG (dB)	Factor (dB)
300	40	58.1	12.2	1.6	31.9	-18.1

$$\text{Factor} = \text{AF} + \text{CL} - \text{AG}$$





### 3.2.6 EUT OPERATING CONDITIONS

The EUT tested system was configured as the statements of 2.4 Unless otherwise a special operating condition is specified in the follows during the testing.

Below 30 MHz

Temperature:	26 °C	Relative Humidity:	60%
Pressure:	1010 hPa	Polarization:	---
Test Voltage:	AC 120V/60Hz		
Test Mode:	TX Mode		

Freq. (MHz)	Reading (dBuV/m)	Limit (dBuV/m)	Margin (dB)	State P/F
--	--	--	--	PASS
--	--	--	--	PASS

**NOTE:**

The amplitude of spurious emissions which are attenuated by more than 20dB below the permissible value has no need to be reported.

Distance extrapolation factor =  $40 \log (\text{specific distance}/\text{test distance})$ (dB);

Limit line = specific limits(dBuv) + distance extrapolation factor.



Between 30MHz – 1000 MHz Radiation Spurious

Temperature:	22.4 °C	Relative Humidity:	52.4%
Pressure:	1010hPa	Phase:	Horizontal
Test Voltage:	AC 120V/60Hz	Test Mode:	Model 1 worst

No.	Mk	Freq.	Reading	Factor	Measurement	Limit	Over	Detector	Antenna Height	Table Degree	Comment
		MHz	dBuV	dB/m	dBuV/m	dBuV/m	dB		cm	degree	
1	*	41.3167	23.43	11.81	35.24	40.00	-4.76	peak			
2		102.7500	22.50	9.84	32.34	43.50	-11.16	peak			
3		199.7500	21.30	11.99	33.29	43.50	-10.21	peak			
4		576.4333	5.51	23.14	28.65	46.00	-17.35	peak			
5		671.8167	7.68	24.45	32.13	46.00	-13.87	peak			
6		720.3167	5.99	25.79	31.78	46.00	-14.22	peak			

Remark:

1. Margin = Result (Result =Reading + Factor )–Limit

66.9 dBuV/m

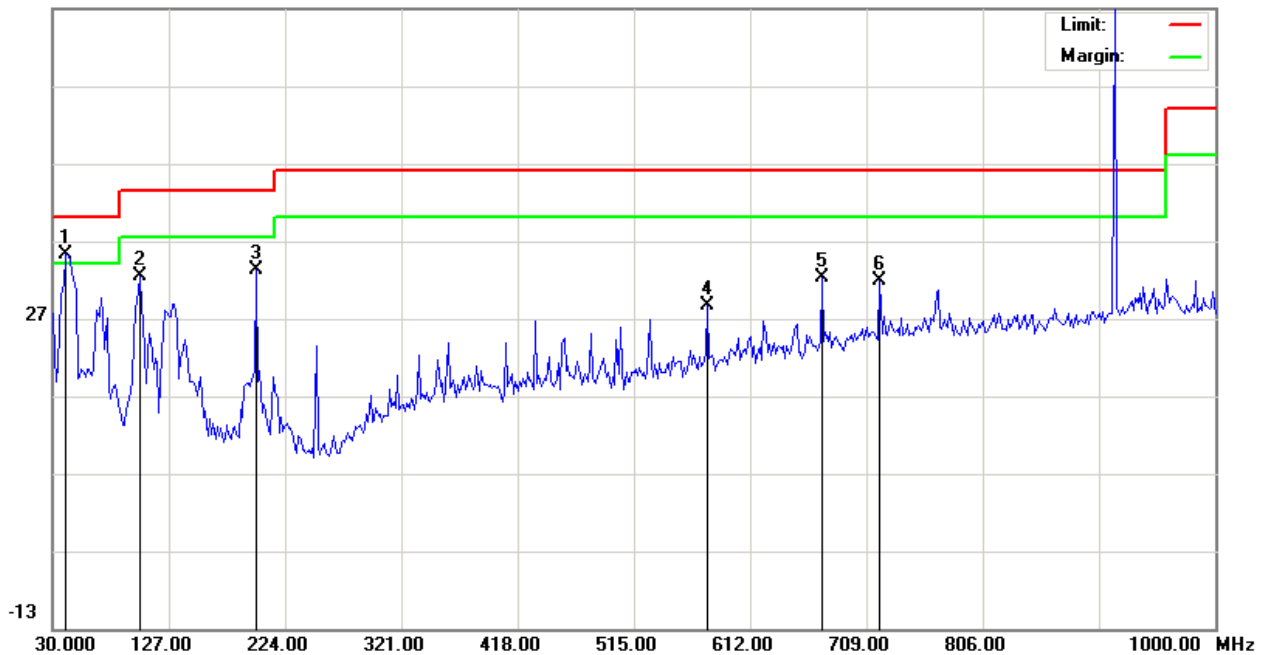



Temperature:	22.4 °C	Relative Humidity:	52.5%
Pressure:	1010hPa	Phase:	Vertical
Test Voltage:	AC 120V/60Hz	Test Mode:	Model 1 worst

No.	Mk	Freq.	Reading	Factor	Measurement	Limit	Over	Detector	Antenna Height	Table Degree	Comment
		MHz	dBuV	dB/m	dBuV/m	dBuV/m	dB		cm	degree	
1	*	31.6167	39.17	-2.09	37.08	40.00	-2.92	peak			
2		115.6833	23.43	4.71	28.14	43.50	-15.36	peak			
3		335.5500	17.30	17.78	35.08	46.00	-10.92	peak			
4		624.9333	11.96	23.29	35.25	46.00	-10.75	peak			
5		768.8165	10.26	26.89	37.15	46.00	-8.85	peak			
6		815.7000	8.46	27.32	35.78	46.00	-10.22	peak			

Remark:

1. Margin = Result (Result = Reading + Factor) - Limit

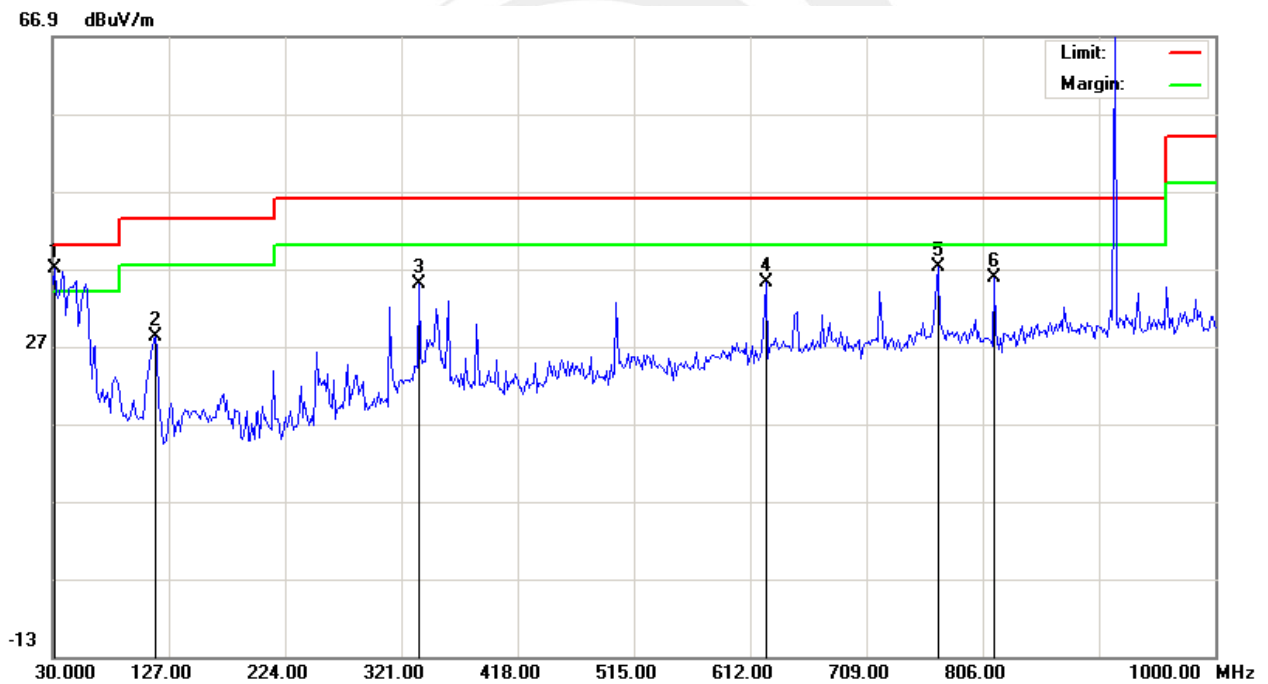



Fundamental frequency:

PK

Frequency (MHz)	Reading (dB $\mu$ V/m)	Amplifier (dB)	Loss (dB)	Antenna Factor (dB/m)	Factor(dB)	Result (dB $\mu$ V/m)	Limit (dB $\mu$ V/m)	Margin(dB)	Polarization
	PEAK				Corr.	PEAK	PEAK	PEAK	
920.6	89.45	40.00	5.73	25.12	-9.15	80.30	114.00	-33.70	Vertical
920.6	89.63	40.00	5.73	25.12	-9.15	80.48	114.00	-33.52	Horizontal
922.0	81.37	40.00	5.73	25.12	-9.15	72.22	114.00	-41.78	Vertical
922.0	82.25	40.00	5.73	25.12	-9.15	73.10	114.00	-40.90	Horizontal
923.4	87.44	40.00	5.73	25.12	-9.15	78.29	114.00	-35.71	Vertical
923.4	88.03	40.00	5.73	25.12	-9.15	78.88	114.00	-35.12	Horizontal

AV

Frequency (MHz)	Reading (dB $\mu$ V/m)	Amplifier (dB)	Loss (dB)	Antenna Factor (dB/m)	Factor(dB)	Result (dB $\mu$ V/m)	Limit (dB $\mu$ V/m)	Margin(dB)	Polarization
	AV				Corr.	AV	PEAK	PEAK	
920.6	70.43	40.00	5.73	25.12	-9.15	61.28	94.00	-32.73	Vertical
920.6	70.12	40.00	5.73	25.12	-9.15	60.97	94.00	-33.03	Horizontal
922.0	65.25	40.00	5.73	25.12	-9.15	56.10	94.00	-37.90	Vertical
922.0	60.26	40.00	5.73	25.12	-9.15	51.11	94.00	-42.89	Horizontal
923.4	67.13	40.00	5.73	25.12	-9.15	57.98	94.00	-36.02	Vertical
923.4	69.36	40.00	5.73	25.12	-9.15	60.21	94.00	-33.79	Horizontal



Above 1G Radiation Spurious

Frequency (MHz)	Reading (dBμV)	Amplifier (dB)	Loss (dB)	Antenna Factor (dB/m)	Corrected Factor (dB)	Emission Level (dBμV/m)	Limits (dBμV/m)	Margin (dB)	Detector Type	Comment
Low Channel (920.6 MHz)										
1100.33	68.08	46.30	3.70	24.30	-18.30	49.78	74	-24.22	PK	Horizontal
1100.33	56.43	46.30	3.70	24.30	-18.30	38.13	54	-15.87	AV	Horizontal
1516.93	65.66	44.90	4.19	25.00	-15.71	49.95	74	-24.05	PK	Vertical
1516.93	56.16	44.90	4.19	25.00	-15.71	40.45	54	-13.55	AV	Vertical
1516.95	66.14	44.90	4.19	25.00	-15.71	50.43	74	-23.57	PK	Horizontal
1516.95	57.92	44.90	4.19	25.00	-15.71	42.21	54	-11.79	AV	Horizontal
1841.27	64.51	44.10	5.30	25.00	-13.80	50.71	74	-23.29	PK	Vertical
1841.27	55.60	44.10	5.30	25.00	-13.80	41.80	54	-12.20	AV	Vertical
1841.22	64.35	44.10	5.30	25.00	-13.80	50.55	74	-23.45	PK	Horizontal
1841.22	54.04	44.10	5.30	25.00	-13.80	40.24	54	-13.76	AV	Horizontal
2144.85	63.50	43.80	5.40	25.90	-12.50	51.00	74	-23.00	PK	Vertical
2144.85	52.21	43.80	5.40	25.90	-12.50	39.71	54	-14.29	AV	Vertical
2145.00	62.79	43.80	5.40	25.90	-12.50	50.29	74	-23.71	PK	Horizontal
2145.00	49.23	43.80	5.40	25.90	-12.50	36.73	54	-17.27	AV	Horizontal
2761.83	66.62	44.40	6.20	27.60	-10.60	56.02	74	-17.98	PK	Vertical
2761.83	51.31	44.40	6.20	27.60	-10.60	40.71	54	-13.29	AV	Vertical
2761.89	65.05	44.40	6.20	27.60	-10.60	54.45	74	-19.55	PK	Horizontal
2761.89	50.73	44.40	6.20	27.60	-10.60	40.13	54	-13.87	AV	Horizontal
3999.86	65.35	44.20	7.90	29.70	-6.60	58.75	74	-15.25	Pk	Vertical
3999.86	47.58	44.20	7.90	29.70	-6.60	40.98	54	-13.02	AV	Vertical
3999.95	68.03	44.20	7.90	29.70	-6.60	61.43	74	-12.57	Pk	Horizontal
3999.95	48.93	44.20	7.90	29.70	-6.60	42.33	54	-11.67	AV	Horizontal
7236.02	55.36	43.50	11.40	35.50	3.40	58.76	74	-15.24	Pk	Vertical
7236.02	38.13	43.50	11.40	35.50	3.40	41.53	54	-12.47	AV	Vertical
7235.94	55.19	43.50	11.40	35.50	3.40	58.59	74	-15.41	Pk	Horizontal
7235.94	38.08	43.50	11.40	35.50	3.40	41.48	54	-12.52	AV	Horizontal
9104.92	53.06	45.00	12.57	37.40	4.97	58.03	74	-15.97	Pk	Vertical
9104.92	40.56	45.00	12.57	37.40	4.97	45.53	54	-8.47	AV	Vertical
9104.74	52.22	45.00	12.57	37.40	4.97	57.19	74	-16.81	Pk	Horizontal
9104.74	38.79	45.00	12.57	37.40	4.97	43.76	54	-10.24	AV	Horizontal





Frequency (MHz)	Reading (dBµV)	Amplifier (dB)	Loss (dB)	Antenna	Corrected	Emission		Margin (dB)	Detector Type	Comment
				Factor (dB/m)	Factor (dB)	Level (dBµV/m)	Limits (dBµV/m)			
Mid Channel (922 MHz)										
1100.01	67.46	46.30	3.70	24.30	-18.30	49.16	74	-24.84	PK	Vertical
1100.01	56.48	46.30	3.70	24.30	-18.30	38.18	54	-15.82	AV	Vertical
1100.11	68.02	46.30	3.70	24.30	-18.30	49.72	74	-24.28	PK	Horizontal
1100.11	56.84	46.30	3.70	24.30	-18.30	38.54	54	-15.46	AV	Horizontal
1516.86	65.98	44.90	4.19	25.00	-15.71	50.27	74	-23.73	PK	Vertical
1516.86	56.33	44.90	4.19	25.00	-15.71	40.62	54	-13.38	AV	Vertical
1517.03	66.24	44.90	4.19	25.00	-15.71	50.53	74	-23.47	PK	Horizontal
1517.03	57.12	44.90	4.19	25.00	-15.71	41.41	54	-12.59	AV	Horizontal
1844.40	64.87	44.10	5.30	25.00	-13.80	51.07	74	-22.93	PK	Vertical
1844.40	55.67	44.10	5.30	25.00	-13.80	41.87	54	-12.13	AV	Vertical
1844.94	65.54	44.10	5.30	25.00	-13.80	51.74	74	-22.26	PK	Horizontal
1844.94	53.87	44.10	5.30	25.00	-13.80	40.07	54	-13.93	AV	Horizontal
2144.85	62.89	43.80	5.40	25.90	-12.50	50.39	74	-23.61	PK	Vertical
2144.85	52.14	43.80	5.40	25.90	-12.50	39.64	54	-14.36	AV	Vertical
2144.91	62.22	43.80	5.40	25.90	-12.50	49.72	74	-24.28	PK	Horizontal
2144.91	50.49	43.80	5.40	25.90	-12.50	37.99	54	-16.01	AV	Horizontal
2766.87	67.39	44.40	6.20	27.60	-10.60	56.79	74	-17.21	PK	Vertical
2766.87	51.36	44.40	6.20	27.60	-10.60	40.76	54	-13.24	AV	Vertical
2766.99	64.98	44.40	6.20	27.60	-10.60	54.38	74	-19.62	PK	Horizontal
2766.99	51.20	44.40	6.20	27.60	-10.60	40.60	54	-13.40	AV	Horizontal
4000.05	65.37	44.20	7.90	29.70	-6.60	58.77	74	-15.23	Pk	Vertical
4000.05	48.25	44.20	7.90	29.70	-6.60	41.65	54	-12.35	AV	Vertical
3999.79	68.07	44.20	7.90	29.70	-6.60	61.47	74	-12.53	Pk	Horizontal
3999.79	48.16	44.20	7.90	29.70	-6.60	41.56	54	-12.44	AV	Horizontal
7236.05	55.90	43.50	11.40	35.50	3.40	59.30	74	-14.70	Pk	Vertical
7236.05	37.86	43.50	11.40	35.50	3.40	41.26	54	-12.74	AV	Vertical
7236.20	56.25	43.50	11.40	35.50	3.40	59.65	74	-14.35	Pk	Horizontal
7236.20	39.16	43.50	11.40	35.50	3.40	42.56	54	-11.44	AV	Horizontal
9104.91	52.88	45.00	12.57	37.40	4.97	57.85	74	-16.15	Pk	Vertical
9104.91	40.66	45.00	12.57	37.40	4.97	45.63	54	-8.37	AV	Vertical
9104.97	53.17	45.00	12.57	37.40	4.97	58.14	74	-15.86	Pk	Horizontal
9104.97	38.82	45.00	12.57	37.40	4.97	43.79	54	-10.21	AV	Horizontal



Frequency (MHz)	Reading (dBµV)	Amplifier (dB)	Loss (dB)	Antenna	Corrected	Emission		Margin (dB)	Detector Type	Comment
				Factor (dB/m)	Factor (dB)	Level (dBµV/m)	Limits (dBµV/m)			
High Channel (923.4 MHz)										
1100.08	67.53	46.30	3.70	24.30	-18.30	49.23	74	-24.77	PK	Horizontal
1100.08	57.26	46.30	3.70	24.30	-18.30	38.96	54	-15.04	AV	Horizontal
1517.00	65.28	44.90	4.19	25.00	-15.71	49.57	74	-24.43	PK	Vertical
1517.00	56.49	44.90	4.19	25.00	-15.71	40.78	54	-13.22	AV	Vertical
1517.02	65.61	44.90	4.19	25.00	-15.71	49.90	74	-24.10	PK	Horizontal
1517.02	57.29	44.90	4.19	25.00	-15.71	41.58	54	-12.42	AV	Horizontal
1846.51	65.70	44.10	5.30	25.00	-13.80	51.90	74	-22.10	PK	Vertical
1846.51	54.47	44.10	5.30	25.00	-13.80	40.67	54	-13.33	AV	Vertical
1846.75	64.44	44.10	5.30	25.00	-13.80	50.64	74	-23.36	PK	Horizontal
1846.75	53.42	44.10	5.30	25.00	-13.80	39.62	54	-14.38	AV	Horizontal
2144.96	62.39	43.80	5.40	25.90	-12.50	49.89	74	-24.11	PK	Vertical
2144.96	52.42	43.80	5.40	25.90	-12.50	39.92	54	-14.08	AV	Vertical
2144.92	62.56	43.80	5.40	25.90	-12.50	50.06	74	-23.94	PK	Horizontal
2144.92	49.67	43.80	5.40	25.90	-12.50	37.17	54	-16.83	AV	Horizontal
2770.86	67.60	44.40	6.20	27.60	-10.60	57.00	74	-17.00	PK	Vertical
2770.86	50.61	44.40	6.20	27.60	-10.60	40.01	54	-13.99	AV	Vertical
2770.03	64.92	44.40	6.20	27.60	-10.60	54.32	74	-19.68	PK	Horizontal
2770.03	51.17	44.40	6.20	27.60	-10.60	40.57	54	-13.43	AV	Horizontal
3264.85	63.27	44.70	6.70	28.20	-9.80	53.47	74	-20.53	PK	Vertical
3264.85	50.32	44.70	6.70	28.20	-9.80	40.52	54	-13.48	AV	Vertical
3265.01	63.45	44.70	6.70	28.20	-9.80	53.65	74	-20.35	PK	Horizontal
3265.01	50.52	44.70	6.70	28.20	-9.80	40.72	54	-13.28	AV	Horizontal
3999.98	64.94	44.20	7.90	29.70	-6.60	58.34	74	-15.66	Pk	Vertical
3999.98	47.17	44.20	7.90	29.70	-6.60	40.57	54	-13.43	AV	Vertical
3999.86	68.43	44.20	7.90	29.70	-6.60	61.83	74	-12.17	Pk	Horizontal
3999.86	48.60	44.20	7.90	29.70	-6.60	42.00	54	-12.00	AV	Horizontal
7236.11	56.14	43.50	11.40	35.50	3.40	59.54	74	-14.46	Pk	Vertical
7236.11	39.07	43.50	11.40	35.50	3.40	42.47	54	-11.53	AV	Vertical
7236.15	55.44	43.50	11.40	35.50	3.40	58.84	74	-15.16	Pk	Horizontal
7236.15	38.34	43.50	11.40	35.50	3.40	41.74	54	-12.26	AV	Horizontal
9104.70	52.56	45.00	12.57	37.40	4.97	57.53	74	-16.47	Pk	Vertical
9104.70	41.57	45.00	12.57	37.40	4.97	46.54	54	-7.46	AV	Vertical
9104.78	52.99	45.00	12.57	37.40	4.97	57.96	74	-16.04	Pk	Horizontal
9104.78	39.42	45.00	12.57	37.40	4.97	44.39	54	-9.61	AV	Horizontal



## Band edge Requirements

Frequency (MHz)	Reading (dB $\mu$ V)	Amplifier (dB)	Loss (dB)	Antenna	Corrected	Emission		Margin (dB)	Detector Type	Comment
				Factor (dB/m)	Factor (dB)	Level (dB $\mu$ V/m)	Limits (dB $\mu$ V/m)			
2-GFSK										
902.00	66.11	43.80	2.82	23.50	-17.48	48.63	74	-25.37	PK	Vertical
902.00	52.39	43.80	2.82	23.50	-12.99	39.40	54	-14.60	AV	Vertical
902.00	66.92	43.80	2.82	23.50	-12.99	53.93	74	-20.07	PK	Horizontal
902.00	51.16	43.80	2.82	23.50	-12.99	38.17	54	-15.83	AV	Horizontal
928.00	68.45	43.80	2.82	23.50	-17.48	50.97	74	-23.03	PK	Vertical
928.00	50.06	43.80	2.82	23.50	-12.78	37.28	54	-16.72	AV	Vertical
928.00	68.44	43.80	2.82	23.50	-12.78	55.66	74	-18.34	PK	Horizontal
928.00	50.24	43.80	2.82	23.50	-12.78	37.46	54	-16.54	AV	Horizontal
<p>Low measurement frequencies is range from 850 to 902 MHz, high measurement frequencies is range from 928 to 1000 MHz.  Only show the worst point data of the emissions in the frequency 850-902 MHz and 928-1000 MHz.</p>										



#### 4. BANDWIDTH TEST

##### 4.1 TEST PROCEDURE

- a. The EUT was directly connected to the spectrum analyzer and antenna output port as show in the block diagram below,
- b. Spectrum Setting : RBW= 100KHz, VBW $\geq$ RBW, Sweep time = Auto.

##### 4.2 TEST SETUP



##### 4.3 EUT OPERATION CONDITIONS

TX mode.

##### 4.4 TEST RESULTS

Temperature:	25 °C	Relative Humidity:	50%
Pressure:	1012 hPa	Test Voltage:	AC 120V/60Hz
Test Channel	Frequency (MHz)	20 dB Bandwidth (MHz)	99% Bandwidth (MHz)
CH01	920.6	0.123	0.103
CH02	922	0.123	0.103
CH03	923.4	0.123	0.103

##### CH01

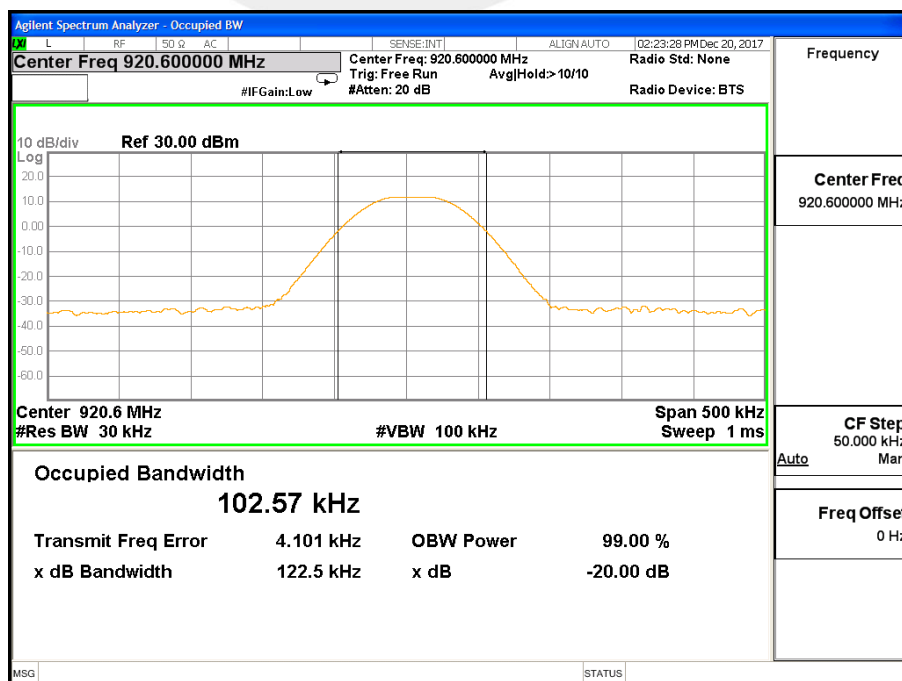



CH02

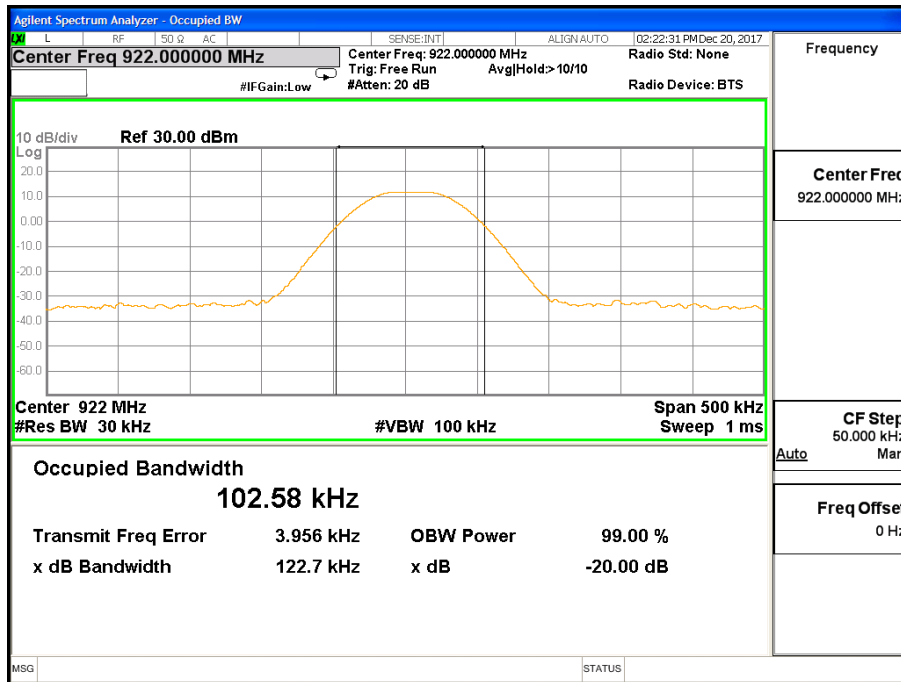

CH03

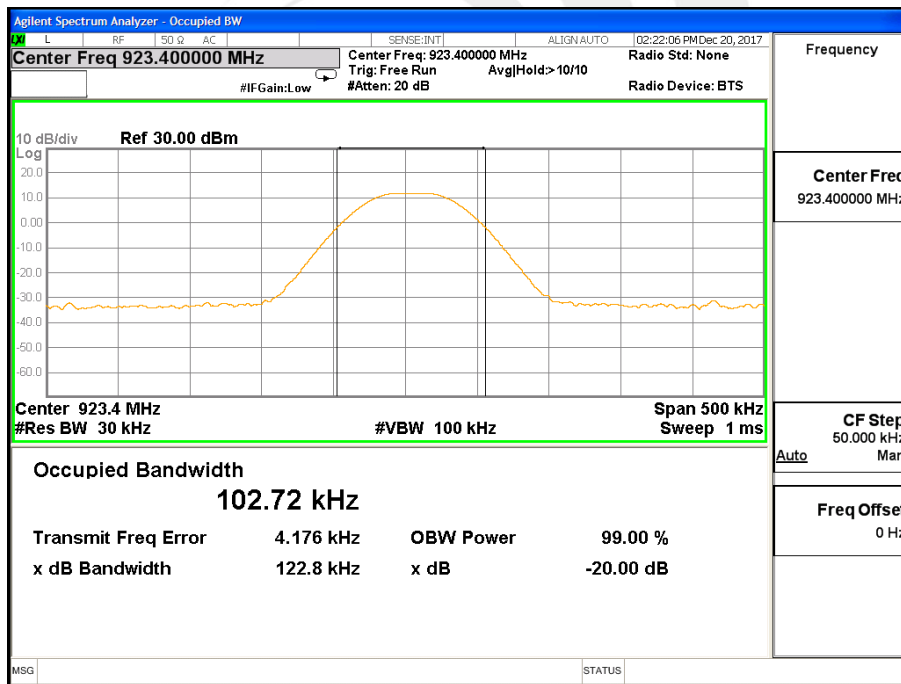



## 5. ANTENNA REQUIREMENT

### 5.1 STANDARD REQUIREMENT

According to the FCC Part 15 Paragraph 15.203, an intentional radiator shall be designed to ensure that no antenna other than that furnished by the responsible party shall be used with the device.

### 5.2 EUT ANTENNA

The EUT antenna is Dipole Antenna. It conforms to the standard requirements.



## APPENDIX I- PHOTOS OF TEST SETUP

### Radiated Measurement Photos

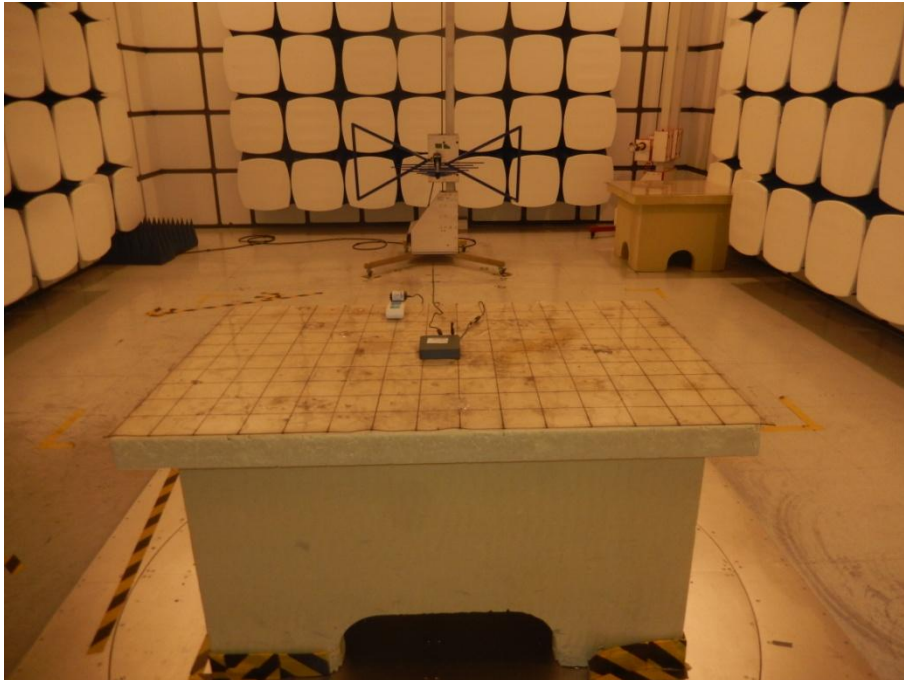



### Conducted Measurement Photos



\*\*\*\*\*END OF THE REPORT\*\*\*\*\*

