

MEAZON DINRAIL 3-PHASE ADVANCED

Installation Guide



Table of Contents

Features & Technical Specifications.....	2
General Installation instructions.....	5
Installation in a three-phase panel	6
CTs installation	6
Power lines L1 L2 L3 installation	6
Installation in a single phase Panel	7
Installation for loads up to 2400A.....	8
External Power Relay installation examples	9
3-phase Power Relay installation	9
1-phase Power Relay installation.....	10
Indication contact installation examples	11
Brief description.....	11
Night tariff indication example	11
Miniature circuit breaker (MCB) indication example.....	11
About MEAZON	12

Features & Technical Specifications

MEAZON has developed “DINRAIL 3-PHASE ADVANCED”, a 3-Phase electricity meter capable of **remote monitoring and controlling** energy consumption of a household and/or an industrial building.

It is a **wireless metering system** based on ZigBee Mesh network technology, featuring a unique design that combines low cost and high accuracy measurements.

Every metering device on the ZigBee network is associated with a ZigBee gateway. The role of the gateway is to periodically collect all measurements, gathered by the devices, in order to forward them to the **MEAZON Cloud** for storage and further analysis.

MEAZON Cloud gives users the ability to monitor the current energy consumption, set alarm rules, control their devices (on/off switching) and schedule them to operate in a desired pattern.

MEAZON DINRAIL 3-PHASE ADVANCED is a rail-type device with small size (1.5 din), can be easily installed and is capable of **monitoring, measurement logging and controlling**:

- *up to three separate power lines / loads*
- *a three phased load*
- *an entire electrical panel (either single-phase, dual-phase or three-phase)*

It comes with **three current transformers** so as to measure any electrical load without limitations.

It can drive a cold junction where a Power Relay could potentially be connected and control (on/off) the power supply to a load.

The Relays control logic can be externally driven using **On/Off commands** or internally using **MEAZON scheduling**.

Finally, MEAZON DINRAIL 3-PHASE ADVANCED is equipped with a **general purpose indication contact**, operating under “**Neutral detection**” logic, which can be used as an extra useful information input to your system.

Communication Specifications

Communication protocol	ZigBee Mesh Network
Frequency band	2.4GHz
Simultaneous operation of multiple metering systems	Yes
Data communication interval	1 second (default 5 minutes)
Response in case of communication loss	Yes (Rerouting through Zigbee)
Security - Communication Encryption	Yes (AES encryption 128 bits)
Data Storage	Up to 25 days

Electrical Specifications

Operating Voltage (*) / Frequency	100-285 Vac / 45-65 Hz
Power loss Response	Automatic resumption of operation after power loss

Electrical measurements

Electrical parameters measured	I_{rms} , V_{rms} , Active Power & Energy, Reactive Power & Energy
Ranges of measured parameters	Voltage: 0 to 285 Vac between phase and Neutral (**) Current: up to 2400 Amps (CT model depended)
Tolerance	+10% of nominal load (I_{ov})
Accuracy of measurements	<1% of reading measurement error (***)

(*) Make sure your purchased DINRAIL 3-PHASE ADVANCED meets your appliances Voltage

(**) At least one of the measured phases must have models nominal Voltage

(***) Accuracy refers to Electric Power Measurements

Mechanical and Environmental Specifications

Power Consumption	5VA
Dimensions (WxHxD)	27.8 x 80.0 x 58.3 in mm
Mass	0.085 Kg
Supply wiring requirements	16 or 18AWG Solid/ Stranded, torque 0.6Nm
Operating Environment	Temperature: -20°C to 50°C Relative Humidity: 10% to 90% RH

Current Transformers (CT) provided

CT 5A, accuracy $\pm 1\%$
CT 63A, accuracy $\pm 1\%$
CT 125A, accuracy $\pm 1\%$
CT 250A, accuracy $\pm 1\%$
CT 400A, accuracy $\pm 1\%$
CT 600A, accuracy $\pm 1\%$

Electrical contacts

Connector	Id	Description	Connector	Id	Description
1	L1	Phase L1	7	RN	Power Relay 100~240Vac Neutral
2	L2	Phase L2	8	-	NO Connect
3	L3	Phase L3	9	-	NO Connect
4	N	Neutral	10	CTR1	Current Transformer 1 Red Wire
5	NT	Night Tariff	11	CTR2	Current Transformer 2 Red Wire
6	CTB	Current Transformers Black Wires	12	CTR3	Current Transformer 3 Red Wire
LED1	L1	Relay On/Off	BUTTON	B	Man/Machine interface Button
LED2	L2	Network status			

Device Status based on led indications L1-LED1 / L2-LED2

LED1On	Relay Switch On
LED1 Off	Relay Switch Off
LED1Slow Blinking LED2 Off	Idle state, not associated with a network, waits for Man/Machine interaction
LED1 Fast Blinking LED2 Off	Beacon state, not associated with a network, in "ready to join" mode
LED1 On/Off LED2 Fast Blinking	Normal operation, network associated, collecting measurements, Relay Switch On or Off
Both LEDS Off	Device is not operating
Both LEDS Blinking in different frequency	Identifying state, network associated, collecting measurements, Relay Switch On or Off
Both LEDS Blinking at the same time	Operating error, device needs restart



Safety Information

Use this product only in the manner described in this manual. If the equipment is used in a manner not specified by the manufacturer, the protection provided by the equipment may be impaired.

Product may be cleaned with a clean soft towel. Do not use liquids to clean.

Product is not water resistant. If the unit gets wet, do not touch it. Power off and allow it to dry thoroughly before further operation.

Do not disassemble the product. There are no spare parts for this, it is not repairable. If physical damage to the product occurs, do not use. Replace with a new one.

MEAZON DINRAIL 3-PHASE ADVANCED Diagram

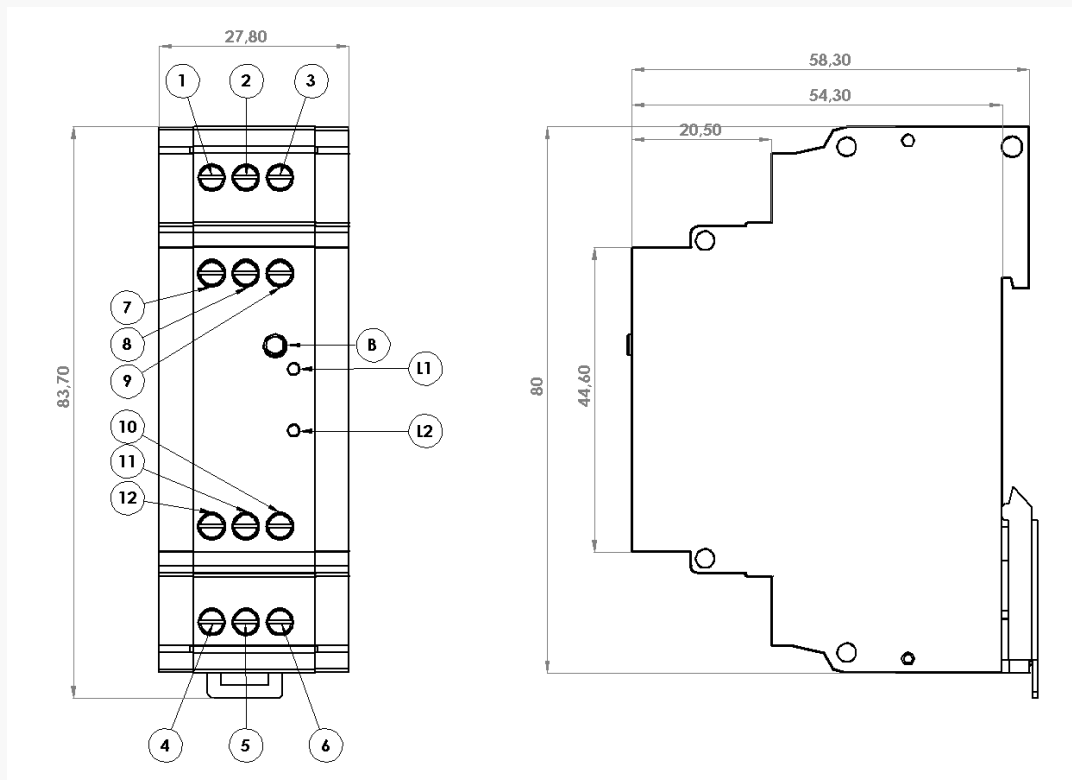

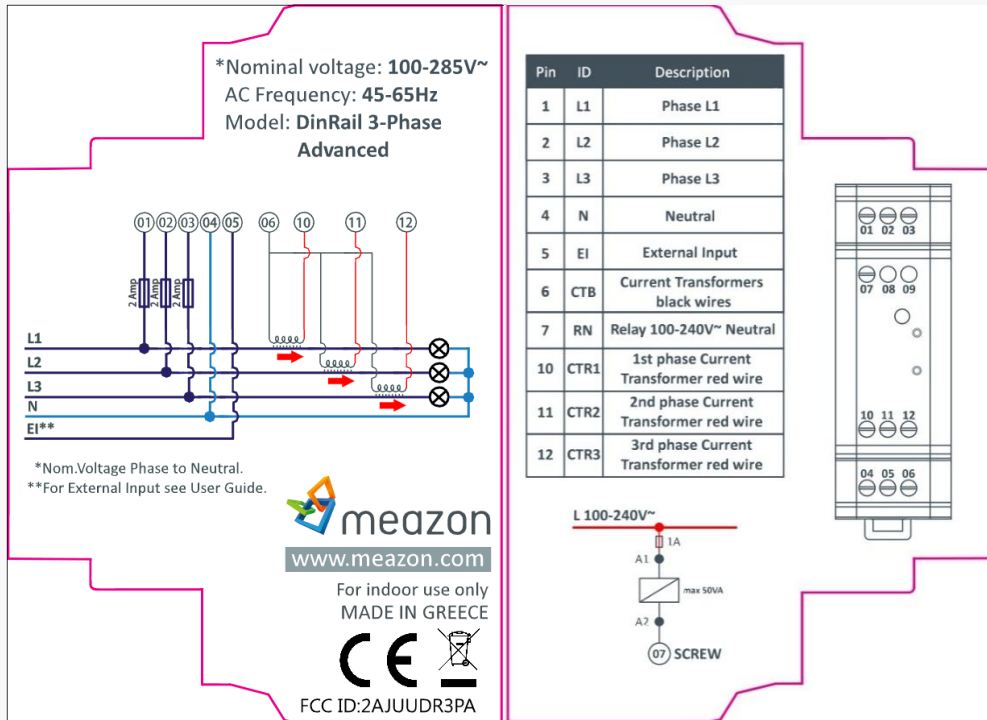

General Installation instructions



INSTALLATION REQUIREMENTS

The instructions provided below, should be performed only by licensed electricians. Installation from non-qualified individuals may lead to electrocution or heavy damage to the devices.

Wiring requirements: 16 or 18AWG Solid/ Stranded, torque 0.6Nm.

Make sure that the maximum amperage to be measured does not exceed the maximum value the provided MEAZON DINRAIL 3-PHASE ADVANCED can measure.

MEAZON DINRAIL 3-PHASE ADVANCED must be protected with a 2A circuit breaker (3 pieces for 3-phase electrical panels, 1 piece for single-phase electrical panels).

- 1) Locate the main electrical panel.
- 2) Turn the power off for safety reasons.
- 3) Locate the current conductors to be measured. Current transformers will be added at those conductors

WARNING! Current conductors should be between the electrical fuse and the circuit breaker (in case of metering electrical loads separately), or between protection relay and electrical fuse (in case of measuring total consumption).

- 4) Check inside the electrical panel for the optimal location to place the MEAZON DINRAIL 3-PHASE ADVANCED as well as the 2A protective circuit breaker.

MEAZON ELECTRONIC SYSTEMS S.A.
 N.E.O PATRON ATHINON 57, 26442, PATRA, Greece
 Greeceinfo@meazon.com support@meazon.com +30 2610 430000
 www.meazon.com

- 5) Place the protective circuit breaker at the rail.
 - 6) Place the DINRAIL having the protection clip downwards and lock it at the rail of the electrical panel
- In this installation guide DINRAIL 3-PHASE ADVANCED will be called DINRAIL for brevity reasons.

Installation in a three-phase panel

CTs installation

- Connect each of the three Current Transformer's outputs (black wire) to contact 6 (CTB) of the DINRAIL.
- Connect each of the three Current Transformer's inputs (red wire) to contact 10 (CTR1), 11 (CRT2) and 12 (CRT3) of the DINRAIL respectively.
- Locate the current conductors to be measured starting from phase L1 and pass it through the coil of the CT (current transformer) by opening the coil of CT.
- Close the CTs coil again. The red wire of this CT must be connected to contact 10 (CTR1) of the DINRAIL.

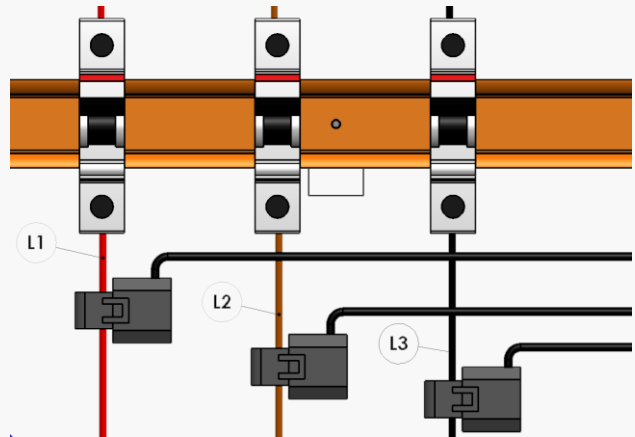

WARNING! Make sure the direction of the arrow illustrated at the CT terminals to the load. Reconnect the current conductor.

- Repeat the process for the other two phases (L2, L3).

Power lines L1 L2 L3 installation

- Power the 2A protective circuit breakers from the main circuit breakers of the electrical panel
- Connect the output of each of the above circuit breakers with the terminal 1(L1), terminal 2(L2) and terminal 3(L3) respectively of the DINRAIL.

WARNING! Make sure that the sequence of phases 1, 2 and 3 of the DINRAIL is strictly L1, L2 and L3, otherwise measurements will be incorrect.

- Connect the neutral conductor of the electrical panel to contact 4(N) of the DINRAIL.
- Check the entire procedure again before completing the installation (sequence of the phases of the inputs of the DINRAIL, sequence of the Current Transformers' connection, direction of the arrow of each CT).

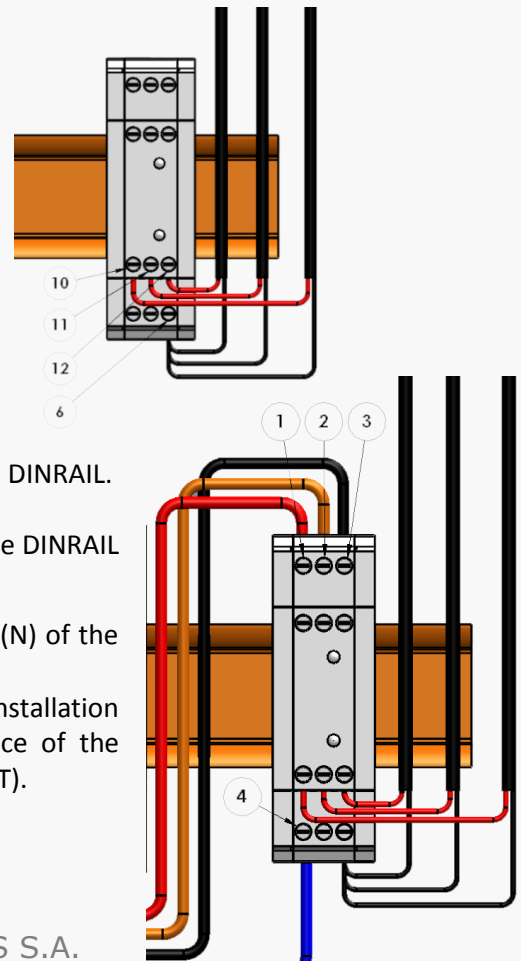

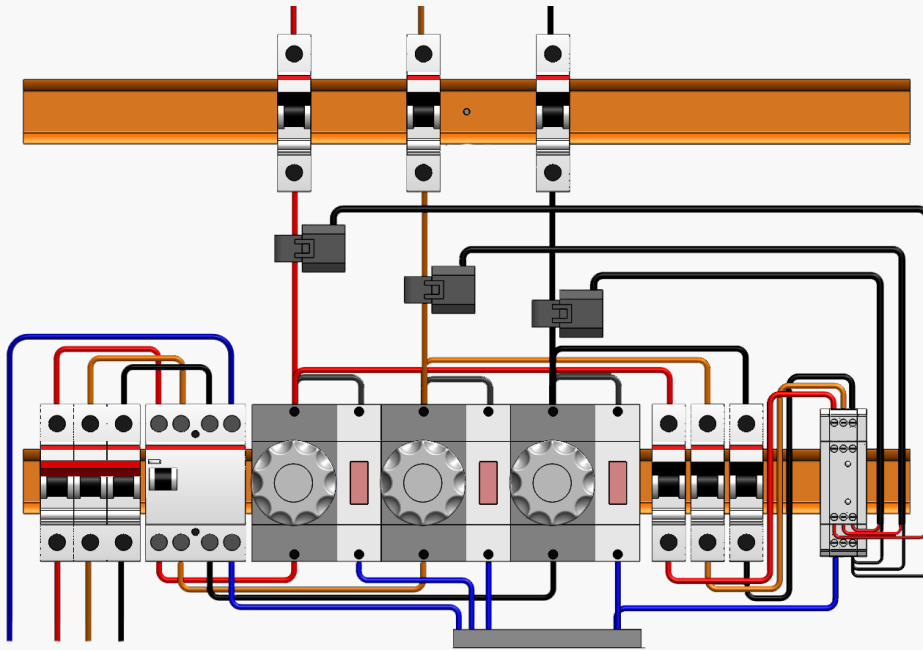

Upon completion of the electrical installation of DINRAIL, the electrical panel should appear as below:

Electrical Panel with DINRAIL 3-PHASE ADVANCED in a 3-Phase Panel

Installation in a single phase Panel

WARNING! You can measure up to three (3) different loads. To do this, follow the instructions of 3-phase installation above. The only change in this procedure is that you have to bridge terminals 1(L1) – 2(L2) - 3(L3).

Electrical Panel with DINRAIL 3-PHASE ADVANCED at Single-Phase Panel

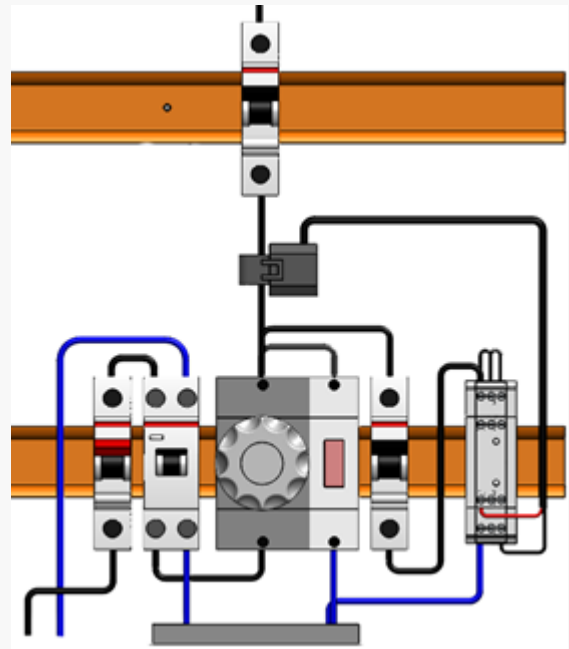

Installation for loads up to 2400A

WARNING! The following instructions relate only for DINRAIL version 5A. Using 5A version you can monitor high current electrical loads up to 2400 Amperes (nominal load).

PRECONDITION! The electrical installation must include current transformers with secondary winding current max output 5 Ampere.

- Follow the instructions of 3-phase installation above.
- Connect a wire to the -K- output of the secondary winding of phase L1 current transformer.
- Pass the wire through the coil of our DINRAIL current transformer provided (the red wire of this CT must be connected to contact 10 -CTR1- of the DINRAIL). The arrow illustrated on our CT must have K-to-L direction.
- Connect the remaining edge of wire to the -L- input of the secondary winding of phase L1 current transformer.
- Repeat the process for the other two current transformers.

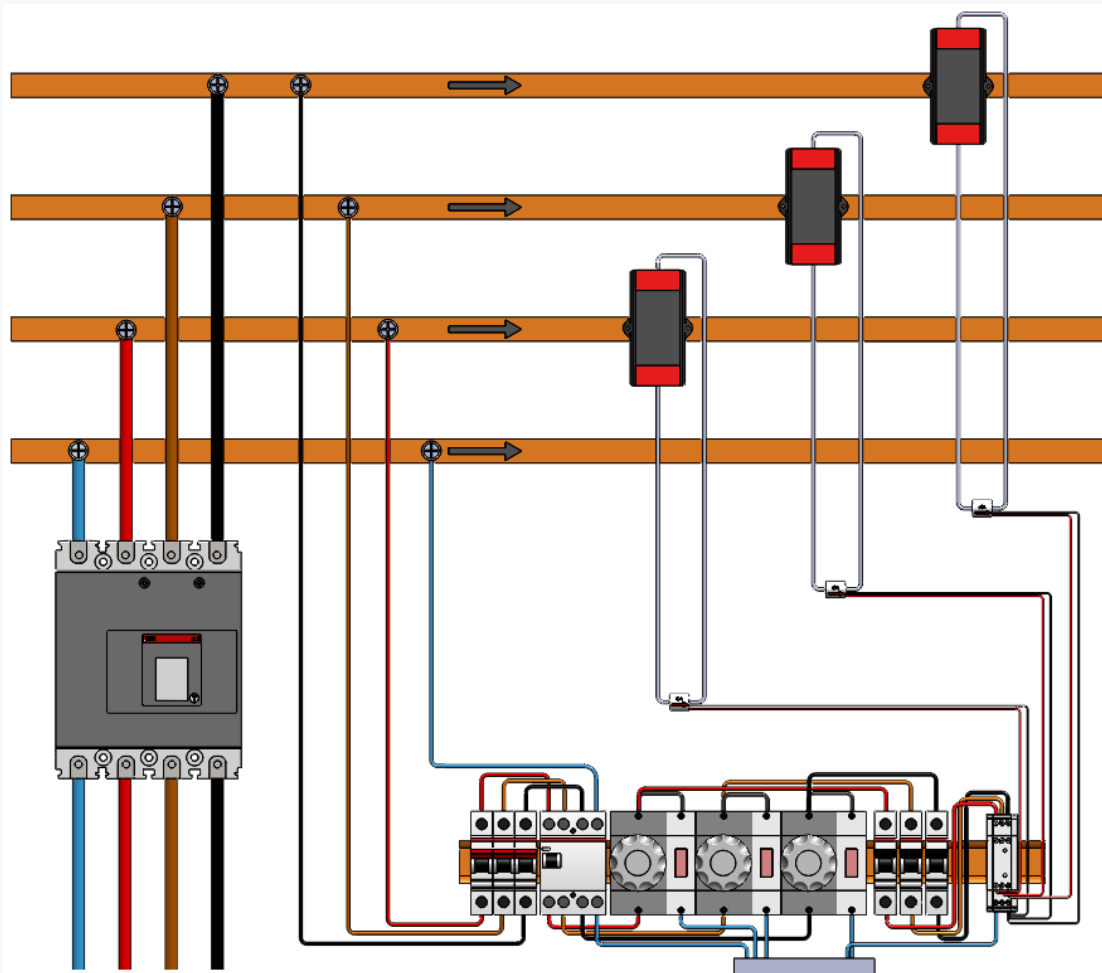

Electrical Panel with DINRAIL 3-PHASE ADVANCED version 5A in a 3-Phase Panel

External Power Relay installation examples

WARNING! Use Power Relays with coil less than 50 VA.

3-phase Power Relay installation

- Place Power Relay at the rail.
- Disconnect the conductors from the loads to be controlled and connect them to the power input connectors of the Power Relay.
- Connect the power outputs of the Power Relay to the loads with the same order.
- Connect a conductor from any phase to the Power Relays Coil input connector.
- Connect a conductor from the Power Relays Coil output connector to the DINRAIL terminal 7 (RN).

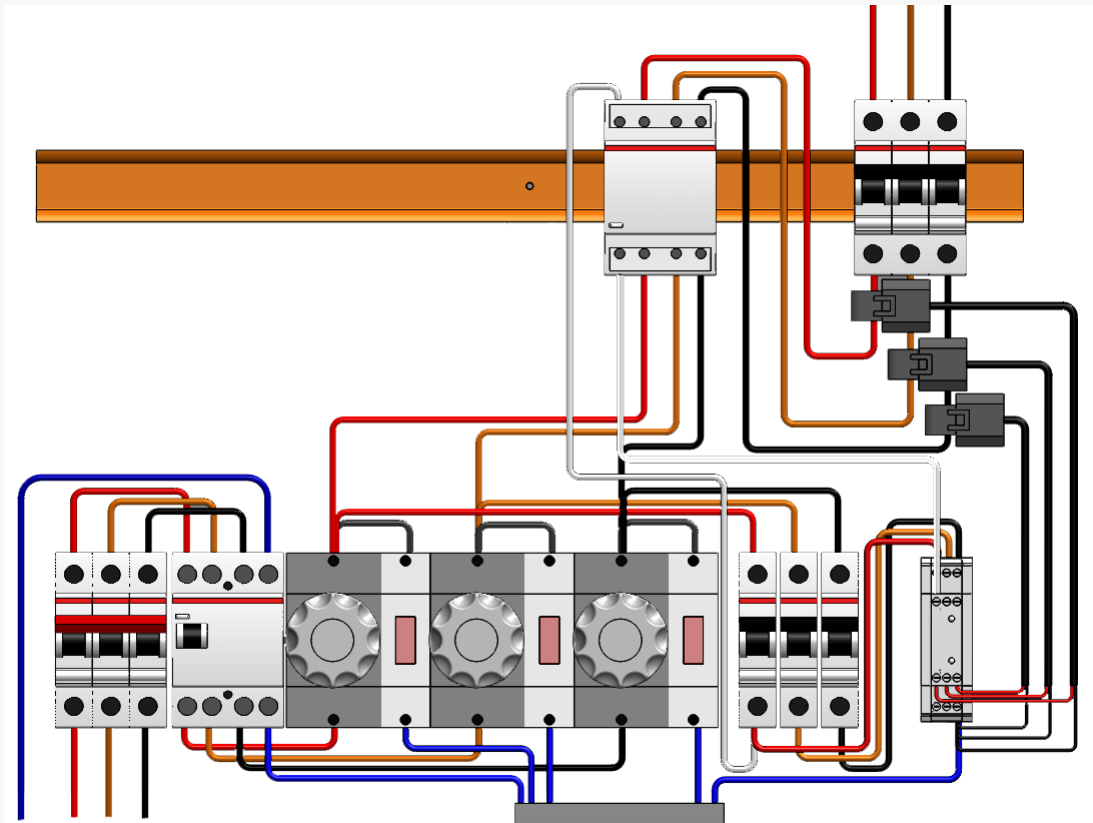

Electrical Panel with DINRAIL 3-PHASE ADVANCED at a 3-Phase Panel and external 3-phase power relay

1-phase Power Relay installation

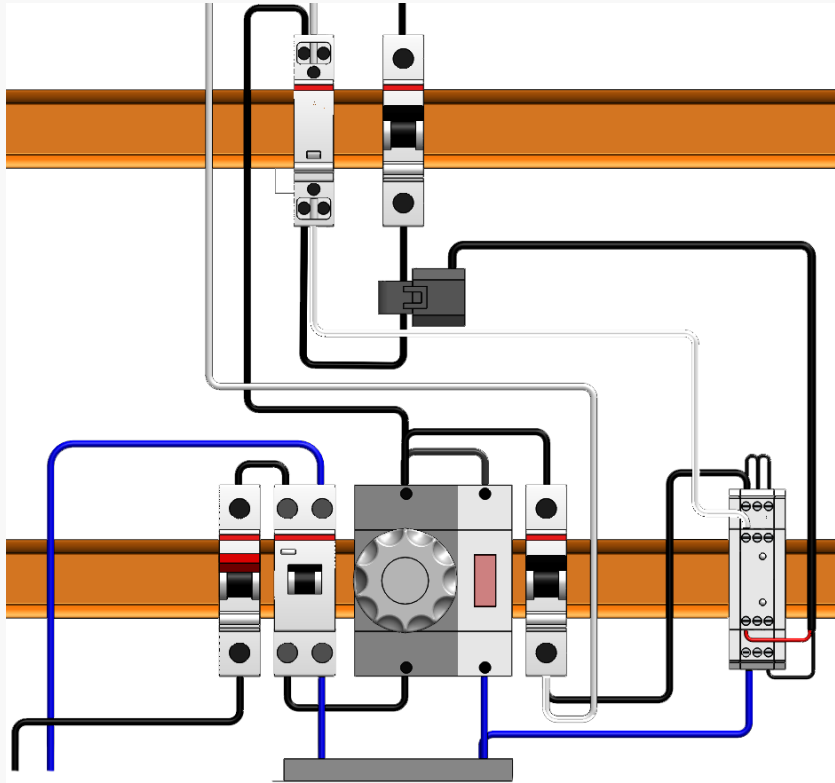

Electrical Panel with DINRAIL 3-PHASE ADVANCED at a single-Phase Panel and external single-phase power relay

Indication contact installation examples

Brief description

DinRail3-Phase Advanced connector 5 (NT) is a general purpose indication contact that can be used as a useful information input to your system, under certain circumstances.

It operates under “Neutral detection” logic. The usage of this contact is shown on the following examples.

Night tariff indication example

- Connect a conductor from the output of the “night tariff” indication led to the DINRAILS connector 5 (NT).

The picture in the right shows how to connect “night tariff” indication. DINRAIL would inform your system for the status of “night tariff” change (enabled or disabled) in your appliance.

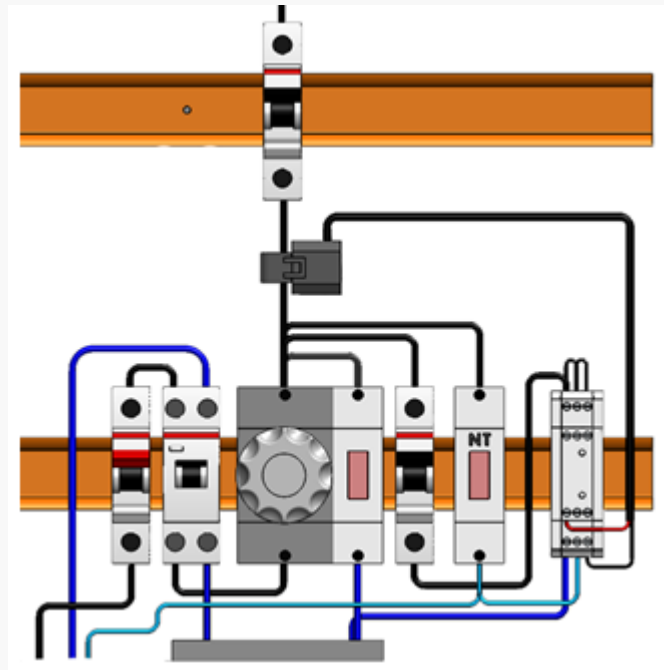

Miniature circuit breaker (MCB) indication example

WARNING! The following connection would have effect only for loads that include Neutral connection. It would not have any effect e.g. for 3-phase loads without neutral.

WARNING! The following connection would have effect only for operating loads. If a load has been stopped e.g. by a switch, DINRAIL would not detect any change of the MCB.

- Connect a conductor from the output of the MCB to the DINRAIL connector 5 (NT).

The picture in the right shows how to connect MCB indication. DINRAIL would inform your system for the status of MCB change (enabled or disabled) in your appliance.

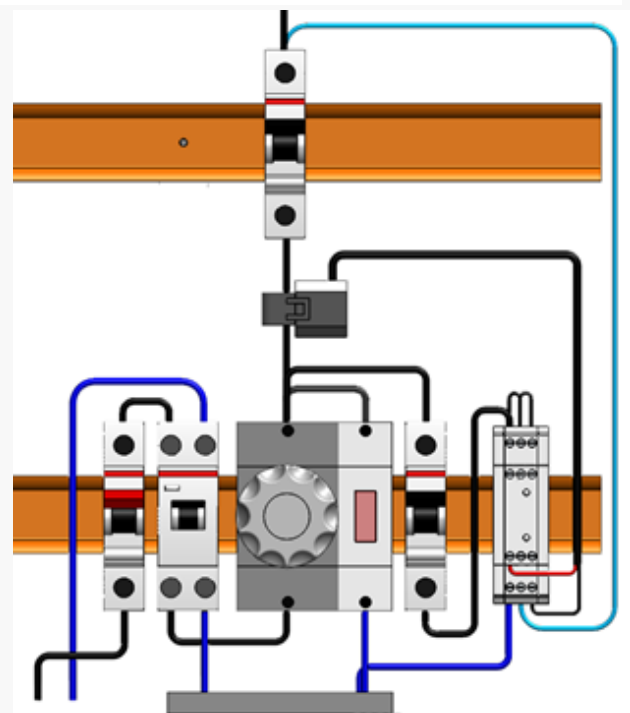

About MEAZON

MEAZON acts as a catalyst to the energy efficiency market. We design and manufacture revolutionary small size energy meters and integrate them with cloud technology. We build on open standards and provide insights in energy consumption of commercial and residential buildings. This way we drive significant energy efficiencies. For more information visit www.meazon.com.



Contact Information

N.E.O PATRON ATHINON 57, 26442, PATRA, Greece

Telephone: +30 2610 430000

24 Fokidos Str., 15126, Ampelokipoi, Athens, Greece

Telephone: +30 210 8020205

E-mail: info@meazon.com

Copyright © 2014, MEAZON S.A.

MEAZON ELECTRONIC SYSTEMS S.A.
N.E.O PATRON ATHINON 57, 26442, PATRA, Greece
Greeceinfo@meazon.com support@meazon.com +30 2610 430000
www.meazon.com

NOTE: This equipment has been tested and found to comply with the limits for a Class B digital device, pursuant to part 15 of the FCC Rules. These limits are designed to provide reasonable protection against harmful interference in a residential installation. This equipment generates uses and can radiate radio frequency energy and, if not installed and used in accordance with the instructions, may cause harmful interference to radio communications. However, there is no guarantee that interference will not occur in a particular installation. If this equipment does cause harmful interference to radio or television reception, which can be determined by turning the equipment off and on, the user is encouraged to try to correct the interference by one or more of the following measures:

- Reorient or relocate the receiving antenna.
- Increase the separation between the equipment and receiver.
- Connect the equipment into an outlet on a circuit different from that to which the receiver is connected.
- Consult the dealer or an experienced radio/TV technician for help

Changes or modifications not expressly approved by the party responsible for compliance could void the user's authority to operate the equipment. This device complies with Part 15 of the FCC Rules. Operation is subject to the following two conditions:

- (1) this device may not cause harmful interference, and
- (2) this device must accept any interference received, including interference that may cause undesired operation.