

FCC TEST REPORT

FCC CFR 47 PART 15 C(15.247): 2015

Report Reference No. : LCS1608313006E

Date of Issue : September 24, 2016

Testing Laboratory Name : Shenzhen LCS Compliance Testing Laboratory Ltd.

Address : 1/F., Xingyuan Industrial Park, Tongda Road, Bao'an Avenue, Bao'an District, Shenzhen, Guangdong, China

Testing Location/ Procedure : Full application of Harmonised standards ■ Partial application of Harmonised standards □ Other standard testing method □

Applicant's Name : Shenzhen Chuang Shi Cai Electronic Co., Ltd.

Address : 1806 Room, 18th Floor, Shiji Hui Duhuixuan, west of Zhonghang Rd, Futian Dist, Shenzhen, China

Test Specification

Standard : FCC CFR 47 PART 15 C(15.247): 2015

Test Report Form No. : LCSEMC-1.0

TRF Originator : Shenzhen LCS Compliance Testing Laboratory Ltd.

Master TRF : Dated 2011-03

Shenzhen LCS Compliance Testing Laboratory Ltd. All rights reserved.

This publication may be reproduced in whole or in part for non-commercial purposes as long as the Shenzhen LCS Compliance Testing Laboratory Ltd. is acknowledged as copyright owner and source of the material. Shenzhen LCS Compliance Testing Laboratory Ltd. takes no responsibility for and will not assume liability for damages resulting from the reader's interpretation of the reproduced material due to its placement and context.

Test Item Description. : Headset

Trade Mark : N/A

Model/ Type reference : EV-BT100

Ratings : DC 3.7V by battery (50mAh) ; Charging voltage: DC 5.0V

Result : Positive

Compiled by:

Aking Jin

Supervised by:

Glin Lu

Approved by:

Gavin Liang

Aking Jin/ File administrators

Glin Lu/ Technique principal

Gavin Liang/ Manager

FCC -- TEST REPORT

Test Report No. : LCS1608313006E	<u>September 24, 2016</u> Date of issue
---	--

Type / Model.....	: EV-BT100
EUT.....	: Headset
Applicant.....	: Shenzhen Chuang Shi Cai Electronic Co., Ltd.
Address.....	: 1806 Room,18th Floor, Shiji Hui Duhuixuan, west of Zhonghang Rd, Futian Dist, Shenzhen, China
Telephone.....	: /
Fax.....	: /
Manufacturer.....	: Shenzhen Chuang Shi Cai Electronic Co., Ltd.
Address.....	: 1806 Room,18th Floor, Shiji Hui Duhuixuan, west of Zhonghang Rd, Futian Dist, Shenzhen, China
Telephone.....	: /
Fax.....	: /
Factory.....	: Shenzhen Chuang Shi Cai Electronic Co., Ltd.
Address.....	: 1806 Room,18th Floor, Shiji Hui Duhuixuan, west of Zhonghang Rd, Futian Dist, Shenzhen, China
Telephone.....	: /
Fax.....	: /

Test Result	Positive
--------------------	-----------------

The test report merely corresponds to the test sample.
It is not permitted to copy extracts of these test result without the written permission of the test laboratory.

Revision History

Revision	Issue Date	Revisions	Revised By
00	2016-09-24	Initial Issue	Gavin Liang

TABLE OF CONTENTS

Description	Page
1. GENERAL INFORMATION	6
1.1 Description of Device (EUT)	6
1.2 Support equipment List.....	6
1.3 External I/O Cable	6
1.4 Description of Test Facility	6
1.5 Statement of The Measurement Uncertainty	7
1.6 Measurement Uncertainty	7
1.7 Description Of Test Modes	7
2. TEST METHODOLOGY	9
2.1 EUT Configuration.....	9
2.2 EUT Exercise	9
2.3 General Test Procedures	9
3. SYSTEM TEST CONFIGURATION	10
3.1 Justification.....	10
3.2 EUT Exercise Software	10
3.3 Special Accessories.....	10
3.4 Block Diagram/Schematics	10
3.5 Equipment Modifications	10
3.6 Test Setup	10
4. SUMMARY OF TEST RESULTS.....	11
5. SUMMARY OF TEST EQUIPMENT	12
6. ANTENNA PORT MEASUREMENT	13
6.1 Peak Power	13
6.2 Frequency Separation And 20 dB Bandwidth.....	14
6.3 Number Of Hopping Frequency	19
6.4 Time Of Occupancy (Dwell Time).....	21
6.5 Conducted Spurious Emissions and Band Edges Test.....	25
7. RADIATED MEASUREMENT	32
7.1 Block Diagram of Test Setup.....	32
7.2 Restricted Band Emission Limit	33
7.3 Instruments Setting	34
7.4 Test Procedures	35
7.5 Results for Restricted Band Radiated Emissions Testing	38
7.6 Results for Restricted Band edge Testing.....	41
7.7. Power line conducted emissions	42
8. ANTENNA REQUIREMENT	45
8.1 Standard Applicable	45
8.2 Antenna Connected Construction.....	45
9. TEST SETUP PHOTOGRAPHS OF EUT	47
10. EXTERIOR PHOTOGRAPHS OF THE EUT	47
11. INTERIOR PHOTOGRAPHS OF THE EUT	47

1. GENERAL INFORMATION

1.1 Description of Device (EUT)

EUT	: Headset
Model Number	: EV-BT100, EV-T10, EV-T20, EV-T30, EV-T50, BT-V10, BT-V20, BT-V30, BT-V60, BY-V200
Model Declaration	: PCB board, structure and internal of these model(s) are the same, So no additional models were tested
Test Model	: EV-BT100
Power Supply	: DC 3.7V by battery (50mAh); Charging voltage: DC 5.0V
Frequency Range	: 2402~2480MHz
Bluetooth Version	: V4.1
Channel Number	: 79 channels
Modulation Technology	: FHSS(GFSK, $\pi/4$ -DQPSK, 8-DPSK)
Data Rates	: 1~3Mbps
Antenna Type And Gain	: PCB Antenna, 0.5dBi

1.2 Support equipment List

Manufacturer	Description	Model	Serial Number	Certificate
Lenovo	PC	B470	--	DOC

1.3 External I/O Cable

I/O Port Description	Quantity	Cable
Micro USB	1	N/A

1.4 Description of Test Facility

CNAS Registration Number. is L4595.
 FCC Registration Number. is 899208.
 Industry Canada Registration Number. is 9642A-1.
 VCCI Registration Number. is C-4260 and R-3804.
 ESMD Registration Number. is ARCB0108.
 UL Registration Number. is 100571-492.
 TUV SUD Registration Number. is SCN1081.
 TUV RH Registration Number. is UA 50296516-001

The 3m-Semi anechoic test site fulfils CISPR 16-1-4 according to ANSI C63.4:2014 and CISPR 16-1-4:2010 SVSWR requirement for radiated emission above 1GHz.

1.5 Statement of The Measurement Uncertainty

The data and results referenced in this document are true and accurate. The reader is cautioned that there may be errors within the calibration limits of the equipment and facilities. The measurement uncertainty was calculated for all measurements listed in this test report acc. To CISPR 16 – 4 “Specification for radio disturbance and immunity measuring apparatus and methods – Part 4: Uncertainty in EMC Measurements” and is documented in the LCS quality system acc. To DIN EN ISO/IEC 17025. Furthermore, component and process variability of devices similar to that tested may result in additional deviation. The manufacturer has the sole responsibility of continued compliance of the device.

1.6 Measurement Uncertainty

Test Item	Frequency Range	Uncertainty	Note
Radiation Uncertainty	9KHz~30MHz	3.10dB	(1)
	30MHz~200MHz	2.96dB	(1)
	200MHz~1000MHz	3.10dB	(1)
	1GHz~26.5GHz	3.80dB	(1)
	26.5GHz~40GHz	3.90dB	(1)
Conduction Uncertainty	150kHz~30MHz	1.63dB	(1)
Power disturbance	30MHz~300MHz	1.60dB	(1)

(1). This uncertainty represents an expanded uncertainty expressed at approximately the 95% confidence level using a coverage factor of k=2.

1.7 Description Of Test Modes

Bluetooth operates in the unlicensed ISM Band at 2.4GHz. With the introduction of the enhanced data rate (EDR) feature, the data rates can be up to 3 Mb/s. An increase in the peak data rate beyond the basic rate of 1 Mb/s is achieved by modulating the RF carrier using GFSK techniques, resulting in an increase of two to three times the number of bits per symbol. The 2 Mb/s EDR packets use $\pi/4$ -DQPSK modulation, and the 3 Mb/s EDR packets use a 8-DPSK modulation. The following operating modes were applied for the related test items. For radiated measurement, the test was performed with EUT in X, Y, Z position and the worse case was found when EUT in X position. All test modes were tested, only the result of the worst case was recorded in the report.

Mode of Operations	Frequency Range (MHz)	Data Rate (Mbps)
GFSK	2402	1
	2441	1
	2480	1
$\pi/4$ DQPSK	2402	2
	2441	2
	2480	2
8-DPSK	2402	3
	2441	3
	2480	3
For Conducted Emission		
Test Mode	TX Mode	
For Radiated Emission		
Test Mode	TX Mode	

Worst-case mode and channel used for 150 kHz-30 MHz power line conducted emissions was the mode and channel with the highest output power that was determined to be TX (1Mbps-Hopping Mode).

Worst-case mode and channel used for 9kHz-1000 MHz radiated emissions was determined to be TX-Low Channel (2402MHz, 1Mbps).

***Note: Using a temporary antenna connector for the EUT when the conducted measurements are performed.

For pre-testing, when performed with LiPo Battery Charger, the input Voltage/Frequency AC 120V/60Hz and AC 240V/60Hz were used. Only recorded the worst case in this report.

Channel List & Frequency

Frequency Band	Channel No.	Frequency(MHz)	Channel No.	Frequency(MHz)
2402~2480MHz	00	2402	39	2441
	01	2403	--	--
	02	2404	--	--
	--	--	76	2478
	--	--	77	2479
	38	2440	78	2480

2. TEST METHODOLOGY

The tests documented in this report were performed in accordance with ANSI C63.10-2013, FCC CFR PART 15C 15.207, 15.209, 15.247 and DA 00-705.

2.1 EUT Configuration

The EUT configuration for testing is installed on RF field strength measurement to meet the Commissions requirement and operating in a manner that intends to maximize its emission characteristics in a continuous normal application.

2.2 EUT Exercise

The EUT was operated in the engineering mode to fix the TX frequency that was for the purpose of the measurements.

According to its specifications, the EUT must comply with the requirements of the Section 15.207, 15.209, 15.247 under the FCC Rules Part 15 Subpart C.

2.3 General Test Procedures

2.3.1 Conducted Emissions

The EUT is directly placed on the ground. According to the requirements in Section 6.2.1 of ANSI C63.10-2013 Conducted emissions from the EUT measured in the frequency range between 0.15 MHz and 30MHz using Quasi-peak and average detector modes.

2.3.2 Radiated Emissions

The EUT is placed on a turntable, which is directly placed on the ground. The turntable shall rotate 360 degrees to determine the position of maximum emission level. EUT is set 3m away from the receiving antenna, which varied from 1m to 4m to find out the highest emission. And also, each emission was to be maximized by changing the polarization of receiving antenna both horizontal and vertical. In order to find out the maximum emissions, exploratory radiated emission measurements were made according to the requirements in Section 6.3 of ANSI C63.10-2013

3. SYSTEM TEST CONFIGURATION

3.1 Justification

The system was configured for testing in a continuous transmit condition.

3.2 EUT Exercise Software

N/A.

3.3 Special Accessories

N/A.

3.4 Block Diagram/Schematics

Please refer to the related document.

3.5 Equipment Modifications

Shenzhen LCS Compliance Testing Laboratory Ltd. has not done any modification on the EUT.

3.6 Test Setup

Please refer to the test setup photo.

4. SUMMARY OF TEST RESULTS

Applied Standard: FCC Part 15 Subpart C		
FCC Rules	Description of Test	Result
§15.247(b)(1)	Maximum Conducted Output Power	Compliant
§15.247(c)	Frequency Separation And 20 dB Bandwidth	Compliant
§15.247(a)(1)(ii)	Number Of Hopping Frequency	Compliant
§15.247(a)(1)(iii)	Time Of Occupancy (Dwell Time)	Compliant
§15.209, §15.205	Conducted Spurious Emissions and Band Edges Test	Compliant
§15.209, §15.247(d)	Radiated and Conducted Spurious Emissions	Compliant
§15.205	Emissions at Restricted Band	Compliant
§15.207(a)	Conducted Emissions	Compliant
§15.203	Antenna Requirements	Compliant
§15.247(i)§2.1093	RF Exposure	Compliant

5. SUMMARY OF TEST EQUIPMENT

Item	Equipment	Manufacturer	Model No.	Serial No.	Last Cal.	Next Cal.
1	Power Sensor	R&S	NRV-Z51	100458	2016-06-18	2017-06-17
2	Power Sensor	R&S	NRV-Z32	10057	2016-06-18	2017-06-17
3	Power Meter	R&S	NRVS	100444	2016-06-18	2017-06-17
4	DC Filter	MPE	23872C	N/A	2016-06-18	2017-06-17
5	RF Cable	Harbour Industries	1452	N/A	2016-06-18	2017-06-17
6	SMA Connector	Harbour Industries	9625	N/A	2016-06-18	2017-06-17
7	Spectrum Analyzer	Agilent	N9020A	MY50510140	2015-10-27	2016-10-26
8	Signal analyzer	Agilent	E4448A(External mixers to 40GHz)	US44300469	2016-06-16	2017-06-15
9	RF Cable	Hubersuhne	Sucoflex104	FP2RX2	2016-06-18	2017-06-17
10	3m Semi Anechoic Chamber	SIDT FRANKONIA	SAC-3M	03CH03-HY	2016-06-18	2017-06-17
11	Amplifier	SCHAFFNER	COA9231A	18667	2016-06-18	2017-06-17
12	Amplifier	Agilent	8449B	3008A02120	2016-06-16	2017-06-15
13	Amplifier	MITEQ	AMF-6F-260400	9121372	2016-06-16	2017-06-15
14	Loop Antenna	R&S	HFH2-Z2	860004/001	2016-06-18	2017-06-17
15	By-log Antenna	SCHWARZBECK	VULB9163	9163-470	2016-06-10	2017-06-09
16	Horn Antenna	EMCO	3115	6741	2016-06-10	2017-06-09
17	Horn Antenna	SCHWARZBECK	BBHA9170	BBHA9170154	2016-06-10	2017-06-09
18	RF Cable-R03m	Jye Bao	RG142	CB021	2016-06-18	2017-06-17
19	RF Cable-HIGH	SUHNER	SUCOFLEX 106	03CH03-HY	2016-06-18	2017-06-17
20	EMI Test Receiver	ROHDE & SCHWARZ	ESCI	101142	2016-06-18	2017-06-17
21	Artificial Mains	ROHDE & SCHWARZ	ENV216	101288	2016-06-18	2017-06-17
22	EMI Test Software	AUDIX	E3	N/A	2016-06-18	2017-06-17

6. ANTENNA PORT MEASUREMENT

6.1 Peak Power

6.1.1 Block Diagram of Test Setup

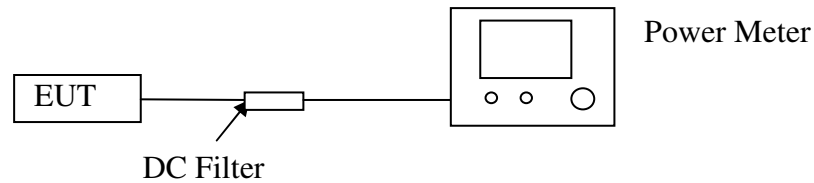

6.1.2 Limit

According to §15.247(b)(1), For frequency hopping systems operating in the 2400–2483.5 MHz band employing at least 75 non-overlapping hopping channels, and all frequency hopping systems in the 5725–5850 MHz band: 1 watt. For all other frequency hopping systems in the 2400–2483.5 MHz band: 0.125 watts.

6.1.3 Test Procedure

The transmitter output (antenna port) was connected to the power meter.

6.1.4 Test Results

Channel	Frequency (MHz)	Peak Output Power (dBm)	Peak Output Power (mw)	Limit (mW)	Result
GFSK	2402	3.501	2.2392	1000	Pass
	2441	3.411	2.1933	1000	Pass
	2480	3.497	2.2372	1000	Pass
$\pi/4$ -DQPSK	2402	3.266	2.1213	125	Pass
	2441	3.110	2.0464	125	Pass
	2480	3.143	2.0621	125	Pass
8-DPSK	2402	3.274	2.1252	125	Pass
	2441	3.354	2.1647	125	Pass
	2480	3.122	2.0521	125	Pass

6.2 Frequency Separation And 20 dB Bandwidth

6.2.1 Limit

According to §15.247(a)(1), Frequency hopping systems shall have hopping channel carrier frequencies separated by a minimum of 25 kHz or the 20 dB bandwidth of the hopping channel, whichever is greater. Alternatively, frequency hopping systems operating in the 2400-2483.5 MHz band may have hopping channel carrier frequencies that are separated by 25 kHz or two-thirds of the 20 dB bandwidth of the hopping channel, whichever is greater, provided the systems operate with an output power no greater than 125 mW.

6.2.2 Block Diagram of Test Setup

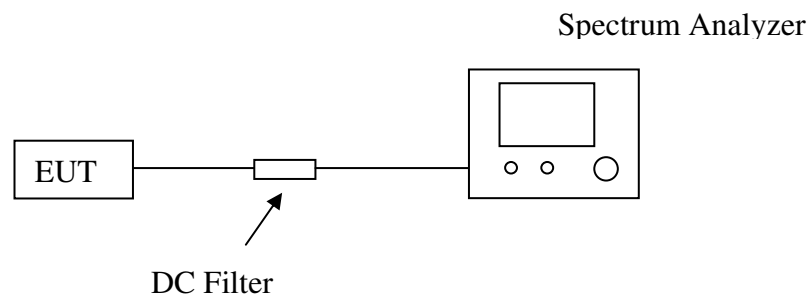

6.2.3 Test Procedure

Frequency separation test procedure :

- 1). Place the EUT on the table and set it in transmitting mode.
- 2). Remove the antenna from the EUT and then connect a low loss RF cable from the antenna port to the Spectrum Analyzer.
- 3). Set center frequency of Spectrum Analyzer = middle of hopping channel.
- 4). Set the Spectrum Analyzer as RBW = 100kHz, VBW = 300kHz, Span = wide enough to capture the peaks of two adjacent channels, Sweep = auto.
- 5). Max hold, mark 2 peaks of hopping channel and record the 2 peaks frequency.

20dB bandwidth test procedure :

- 1). Span = approximately 2 to 3 times the 20 dB bandwidth, centered on a hopping channel.
- 2). RBW \geq 1% of the 20 dB bandwidth, VBW \geq RBW.
- 3). Detector function = peak.
- 4). Trace = max hold.

6.2.4 Test Results

The Measurement Result With 1Mbps For GFSK Modulation				
Channel	20dB Bandwidth (KHz)	Channel Separation (MHz)	Limit (MHz)	Result
Low	864.3	1.000	≥ 25 KHz or 20 dB BW	Pass
Middle	859.2		≥ 25 KHz or 20 dB BW	Pass
High	869.2		≥ 25 KHz or 20 dB BW	Pass
The Measurement Result With 2Mbps For $\pi/4$ -DQPSK Modulation				
Channel	20dB Bandwidth (MHz)	Channel Separation (MHz)	Limit (MHz)	Result
Low	1.220	1.000	≥ 25 KHz or 2/3 20 dB BW	Pass
Middle	1.245		≥ 25 KHz or 2/3 20 dB BW	Pass
High	1.247		≥ 25 KHz or 2/3 20 dB BW	Pass
The Measurement Result With 3Mbps For 8-DPSK Modulation				
Channel	20dB Bandwidth (MHz)	Channel Separation (MHz)	Limit (MHz)	Result
Low	1.220	1.000	≥ 25 KHz or 2/3 20 dB BW	Pass
Middle	1.218		≥ 25 KHz or 2/3 20 dB BW	Pass
High	1.219		≥ 25 KHz or 2/3 20 dB BW	Pass

Note: The test data refer to the following page.

Test Plot of Test Result

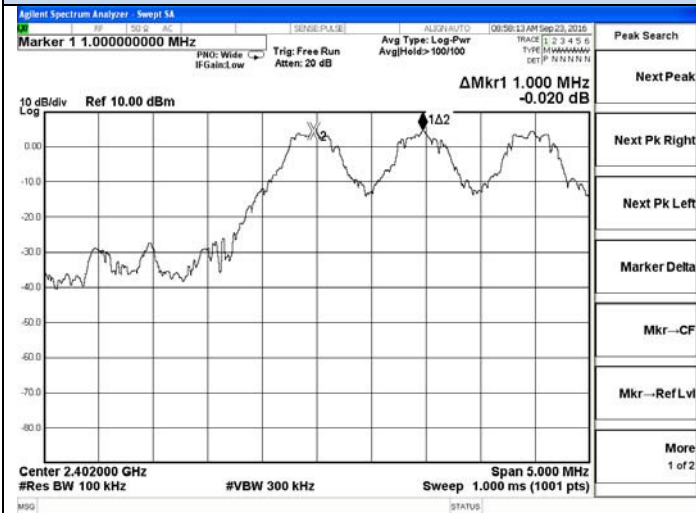

Frequency Separation GFSK-Low channel

20dB Bandwidth GFSK-Low channel

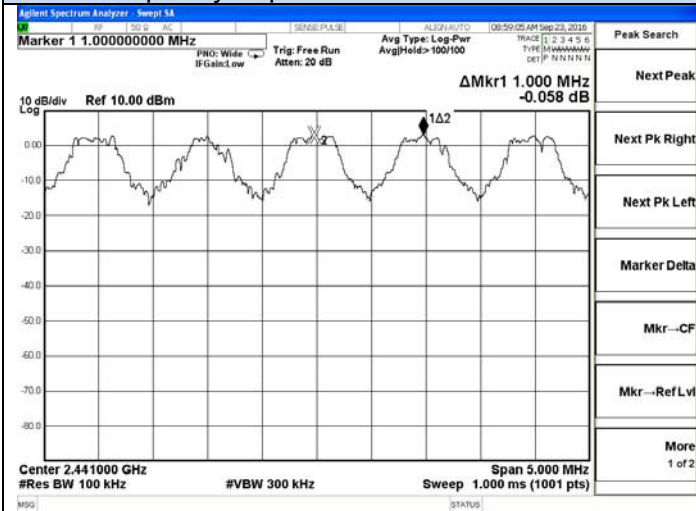

Frequency Separation GFSK-Middle channel

20dB Bandwidth GFSK-Middle channel

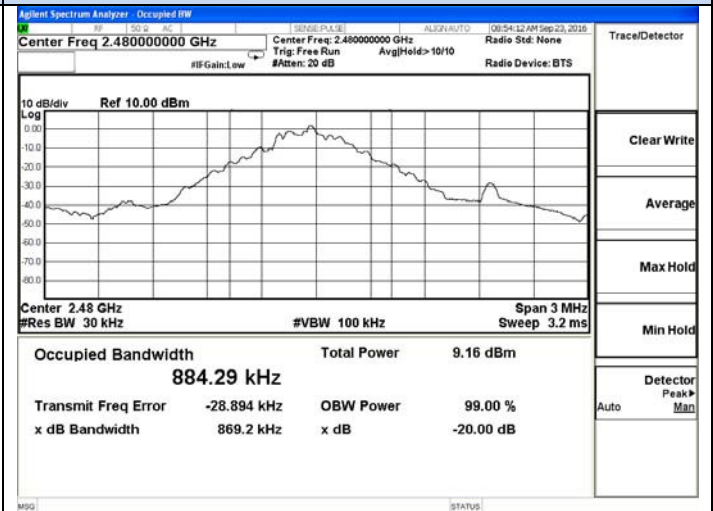
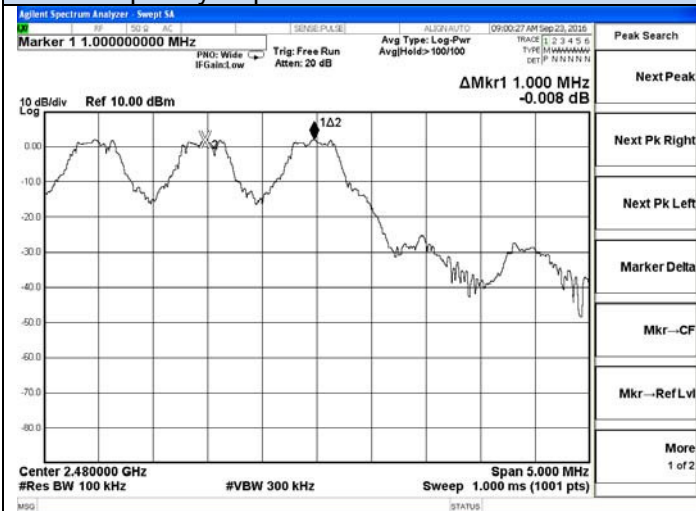

Frequency Separation GFSK-High channel

20dB Bandwidth GFSK-High channel

Test Plot of Test Result

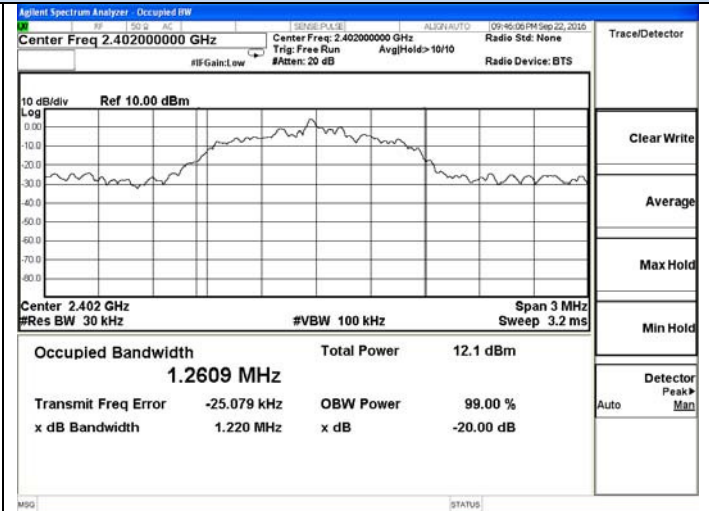

Frequency Separation $\pi/4$ -DQPSK-Low channel

20dB Bandwidth $\pi/4$ -DQPSK-Low channel

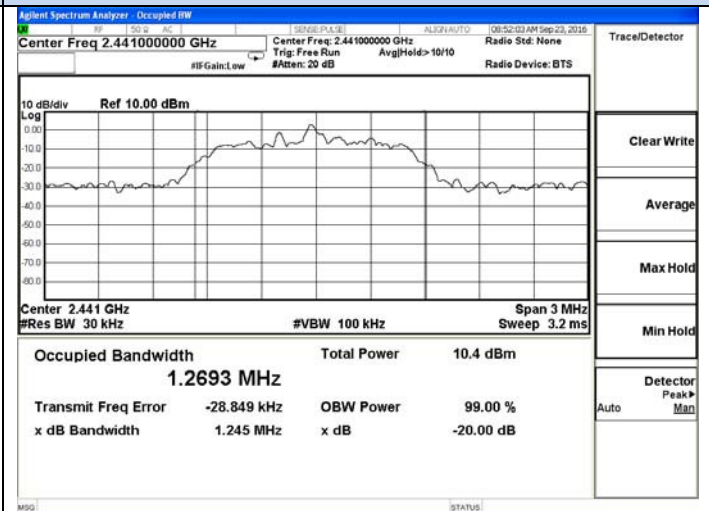
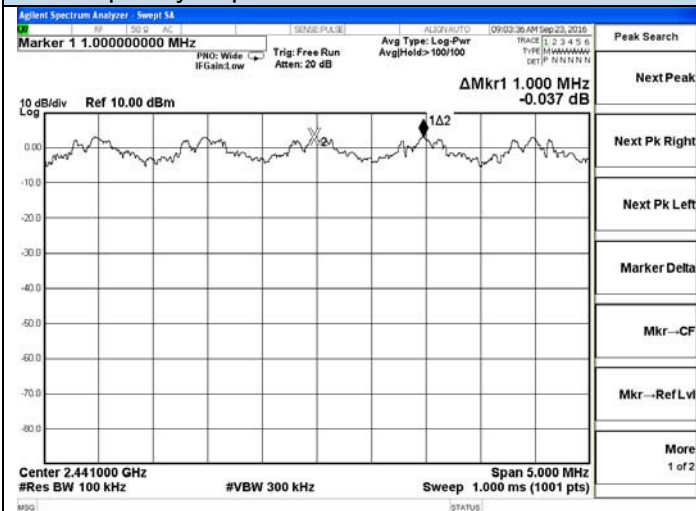

Frequency Separation $\pi/4$ -DQPSK-Middle channel

20dB Bandwidth $\pi/4$ -DQPSK-Middle channel

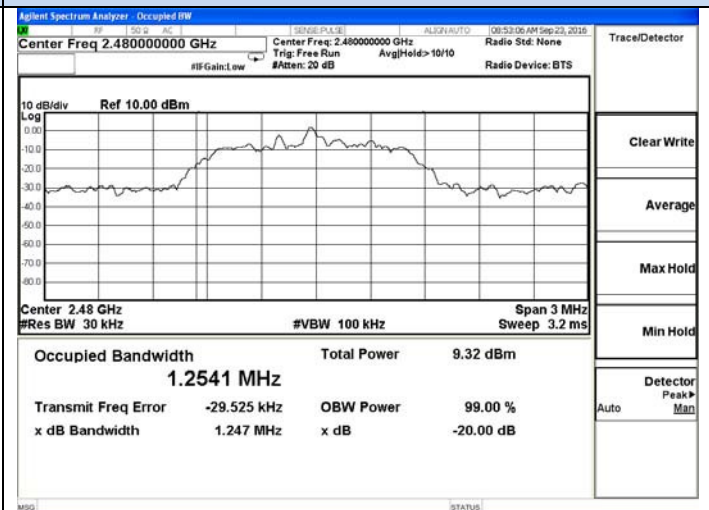

Frequency Separation $\pi/4$ -DQPSK-High channel

20dB Bandwidth $\pi/4$ -DQPSK-High channel

Test Plot of Test Result

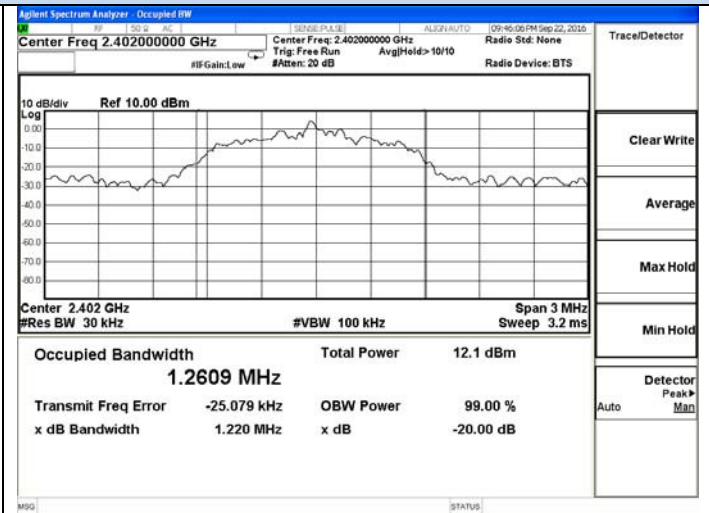

Frequency Separation 8-DPSK-Low channel

20dB Bandwidth 8-DPSK-Low channel

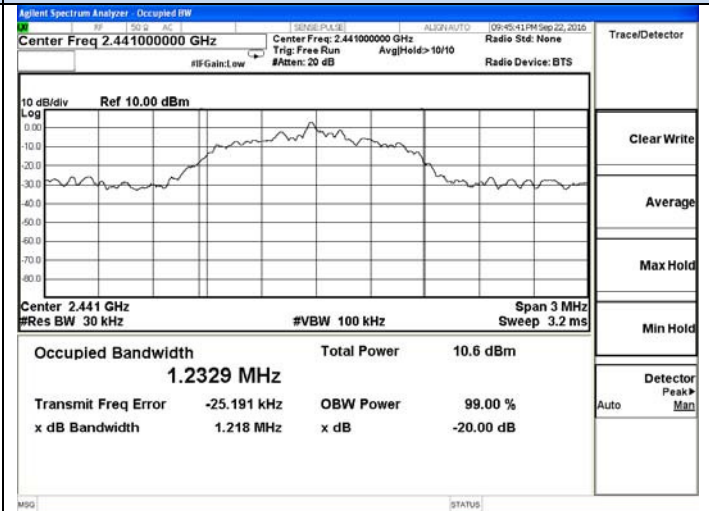
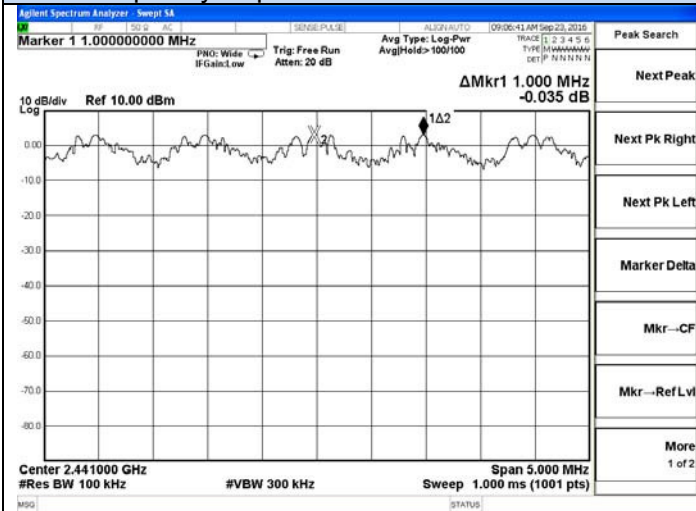

Frequency Separation 8-DPSK-Middle channel

20dB Bandwidth 8-DPSK-Middle channel

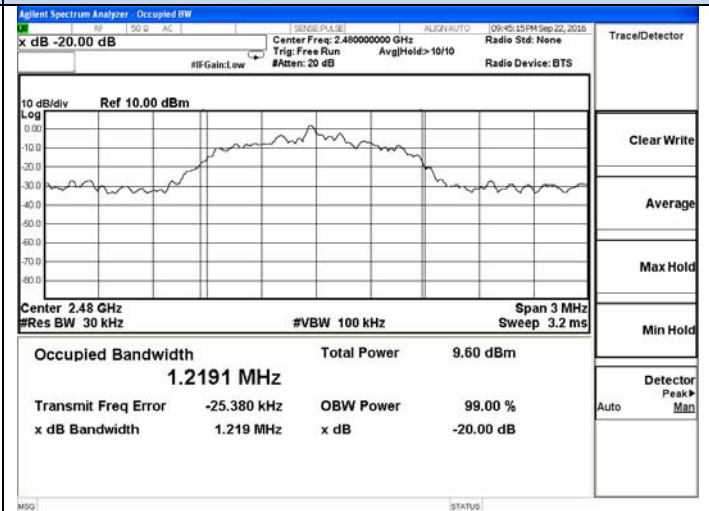

Frequency Separation 8-DPSK-High channel

20dB Bandwidth 8-DPSK-High channel

6.3 Number Of Hopping Frequency

6.3.1 Limit

According to §15.247(a)(1)(ii) or A8.1 (d), Frequency hopping systems operating in the band 2400-2483.5 MHz shall use at least 15 hopping channels.

6.3.2 Block Diagram of Test Setup

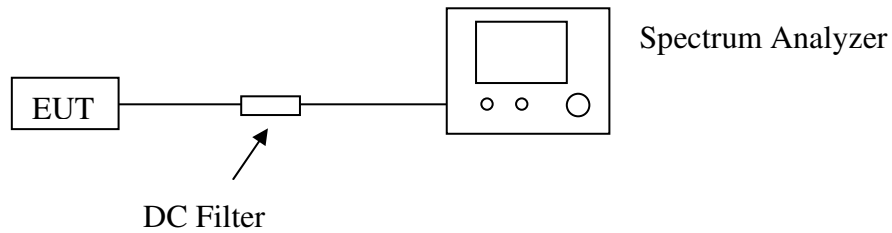

6.3.3 Test Procedure

- 1). Place the EUT on the table and set it in transmitting mode.
- 2). Remove the antenna from the EUT and then connect a low loss RF cable from the antenna port to the Spectrum Analyzer.
- 3). Set Spectrum Analyzer Start=2400MHz, Stop = 2483.5MHz, Sweep = auto.
- 4). Set the Spectrum Analyzer as RBW, VBW=1MHz.
- 5). Max hold, view and count how many channel in the band.

6.3.4 Test Results

The Measurement Result With The Worst Case of 1Mbps For GFSK Modulation			
Total No. of Hopping Channel	Measurement Result (No. of Ch)	Limit (MHz)	Result
	79	≥15	Pass

Note: The test data refer to the following page.

Test plot of Number Of Hopping Frequency

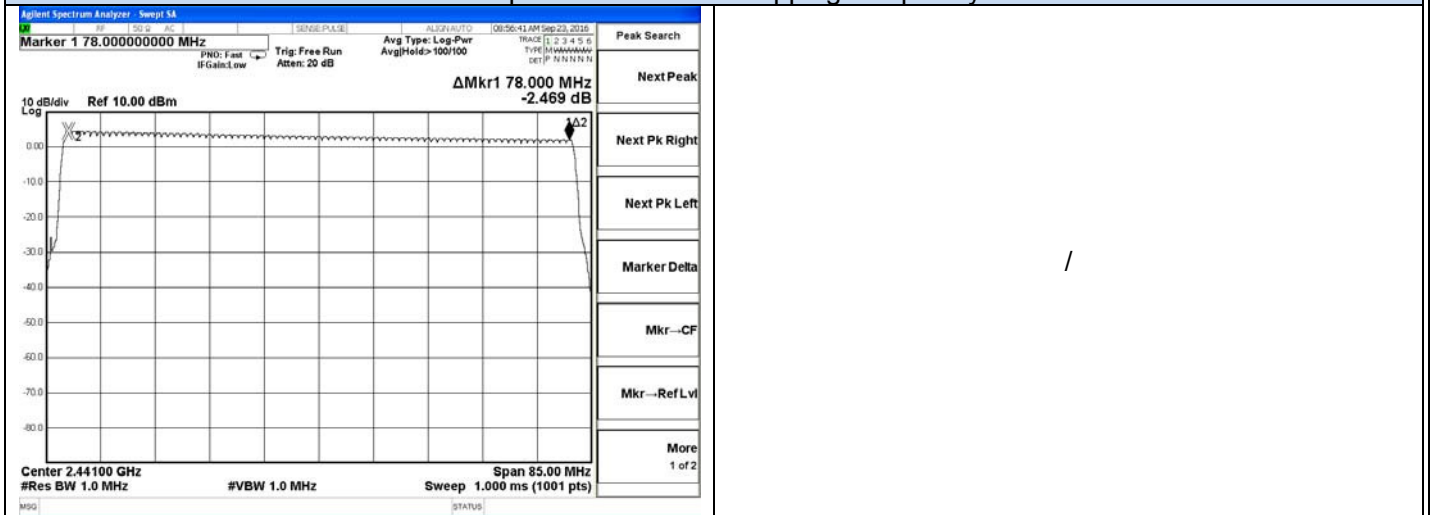

6.4 Time Of Occupancy (Dwell Time)

6.4.1 Limit

According to §15.247(a)(1)(iii) or A8.1 (d), Frequency hopping systems operating in the 2400MHz-2483.5 MHz bands. The average time of occupancy on any channels shall not greater than 0.4 s within a period 0.4 s multiplied by the number of hopping channels employed.

6.4.2 Block Diagram of Test Setup

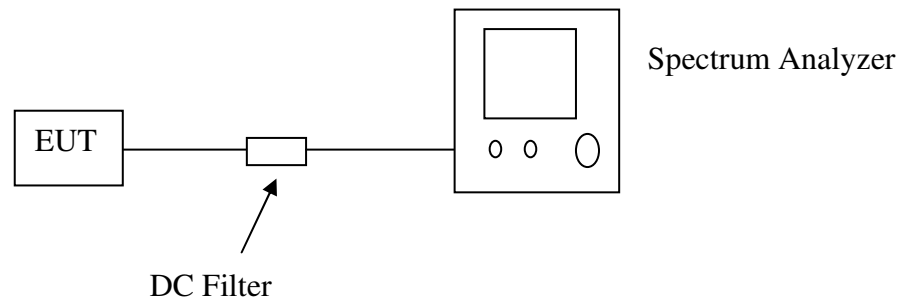

6.4.3 Test Procedure

- 1). Place the EUT on the table and set it in transmitting mode.
- 2). Remove the antenna from the EUT and then connect a low loss RF cable from the antenna port to the Spectrum Analyzer.
- 3). Set center frequency of Spectrum Analyzer = operating frequency.
- 4). Set the Spectrum Analyzer as RBW, VBW=1MHz, Span = 0Hz, Sweep = auto.
- 5). Repeat above procedures until all frequency measured were complete.

6.4.4 Test Results

The Measurement Result				
Test Mode	Time of Pulse (ms)	Period Time (s)	Dwell Time (ms)	Limit (ms)
DH1-2441MHz	0.420	31.6	134.4	400
DH3-2441MHz	1.680	31.6	268.8	400
DH5-2441MHz	2.928	31.6	312.3	400
2DH1-2441MHz	0.432	31.6	138.2	400
2DH3-2441MHz	1.680	31.6	268.8	400
2DH5-2441MHz	2.928	31.6	312.3	400
3DH1-2441MHz	0.428	31.6	137.0	400
3DH3-2441MHz	1.680	31.6	268.8	400
3DH5-2441MHz	2.928	31.6	312.3	400

Calculation formula:**DH1/2DH1/3DH1**

Dwell Time =Burst Length (ms)*(1600/2)/79*31.6

DH3/2DH3/3DH3

Dwell Time =Burst Length (ms)*(1600/4)/79*31.6

DH5/2DH5/3DH5

Dwell Time =Burst Length (ms)*(1600/6)/79*31.6

The test data refer to the following page:

Test plot of Dwell time

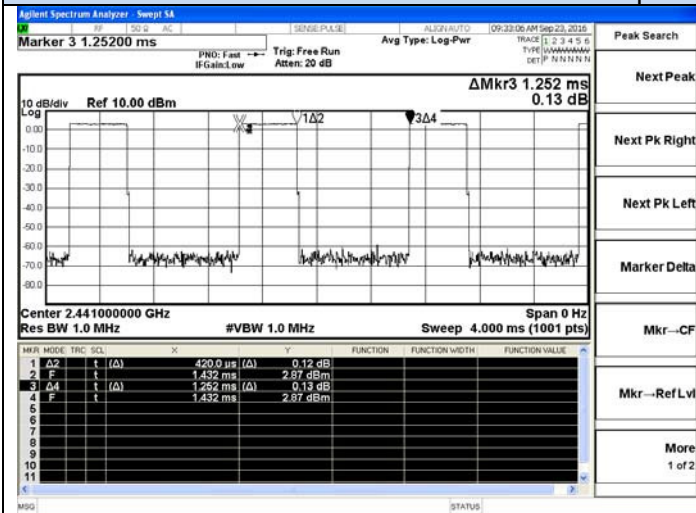

DH1-2441MHz

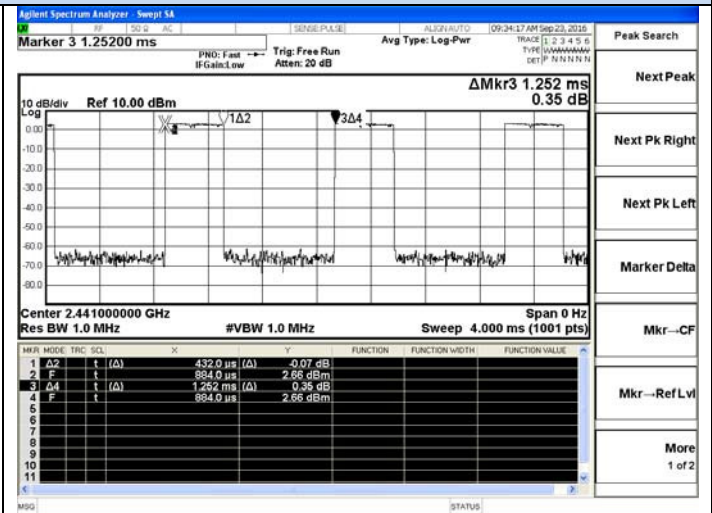

2DH1-2441MHz

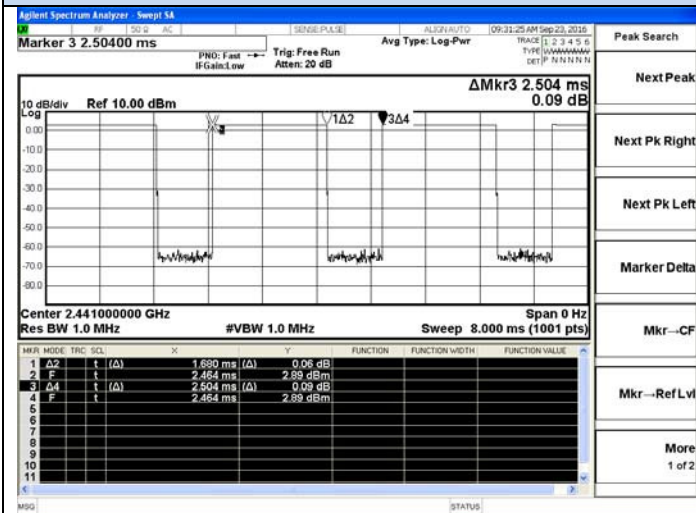

DH3-2441MHz

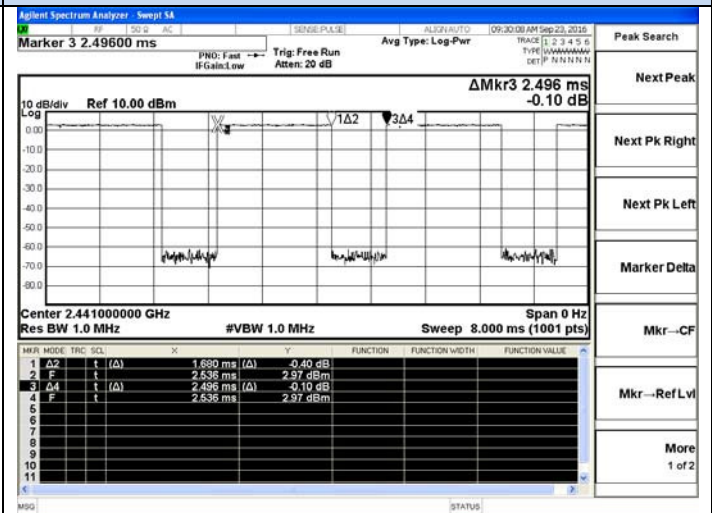

2DH3-2441MHz

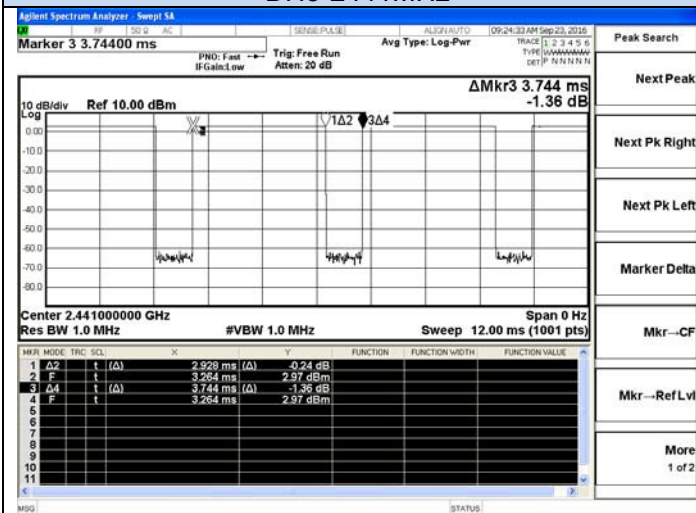

DH5-2441MHz

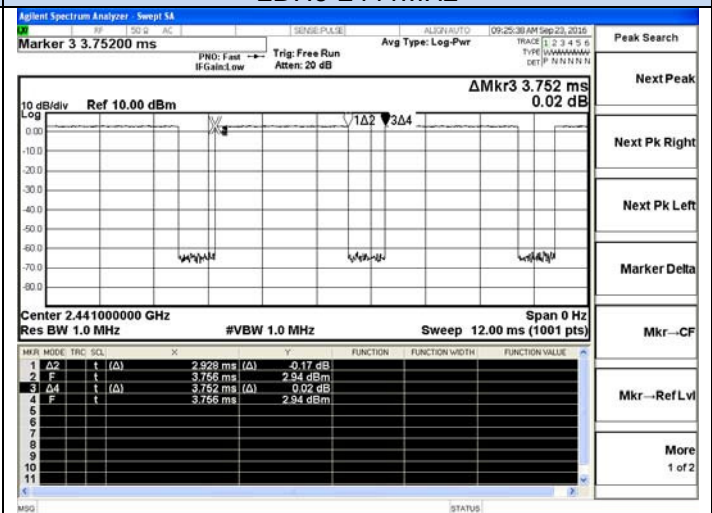

2DH5-2441MHz

Test plot of Dwell time

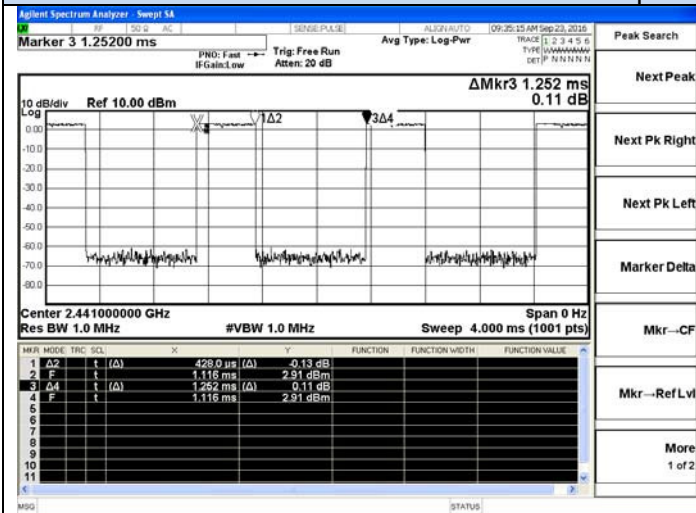

3DH1-2441MHz

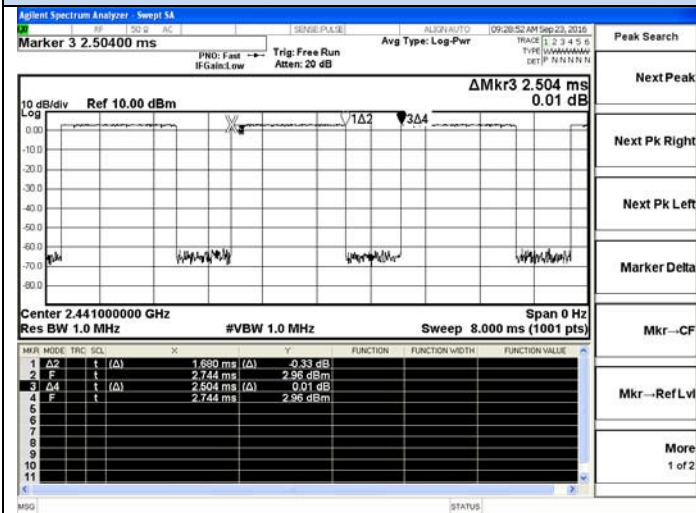

3DH3-2441MHz

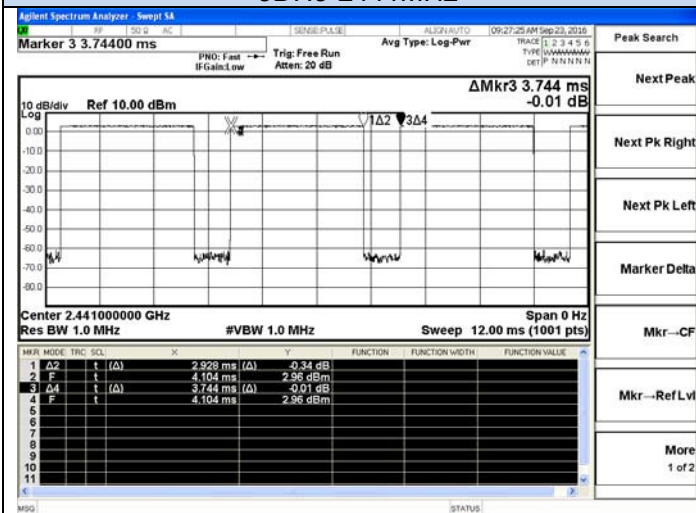

3DH5-2441MHz

6.5 Conducted Spurious Emissions and Band Edges Test

6.5.1 Limit

In any 100 kHz bandwidth outside the frequency band in which the spread spectrum or digitally modulated intentional radiator is operating, the radio frequency power that is produced by the intentional radiator shall be at least 20 dB below that in the 100 kHz bandwidth within the band that contains the highest level of the desired power, based on either an RF conducted or a radiated measurement. Attenuation below the general limits specified in Section 15.209(a) is not required.

6.5.2 Block Diagram of Test Setup

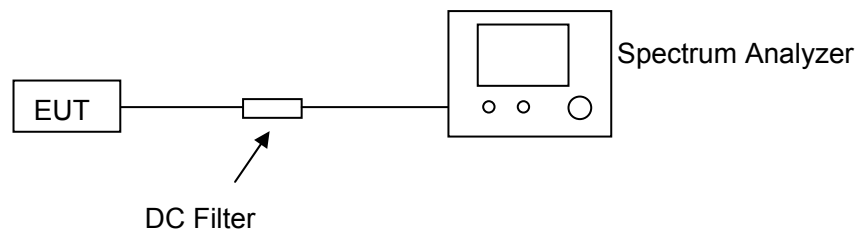

6.5.3 Test Procedure

Conducted RF measurements of the transmitter output were made to confirm that the EUT antenna port conducted emissions meet the specified limit and to identify any spurious signals that require further investigation or measurements on the radiated emissions site.

The transmitter output is connected to the spectrum analyzer. The resolution bandwidth is set to 100 KHz. The video bandwidth is set to 300 KHz.

Measurements are made over the 9kHz to 26.5GHz range with the transmitter set to the lowest, middle, and highest channels

6.5.4 Test Results of Conducted Spurious Emissions

No non-compliance noted. Only record the worst test result (TX-GFSK) in this report. The test data refer to the following page.

Test plot of Conducted Emission(9kHz~ 26.5GHz)

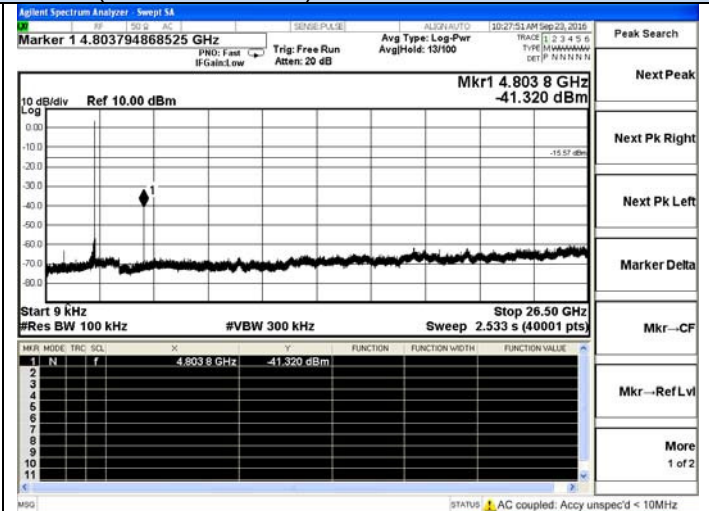
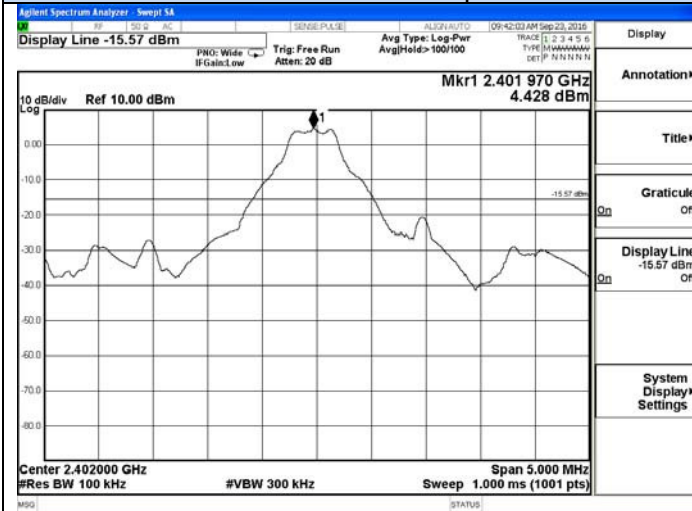

Reference of DH1-Low channel

DH1-Low channel

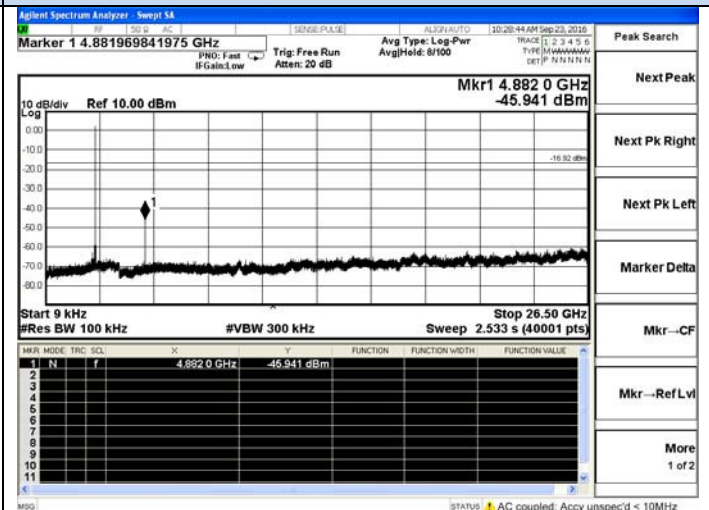
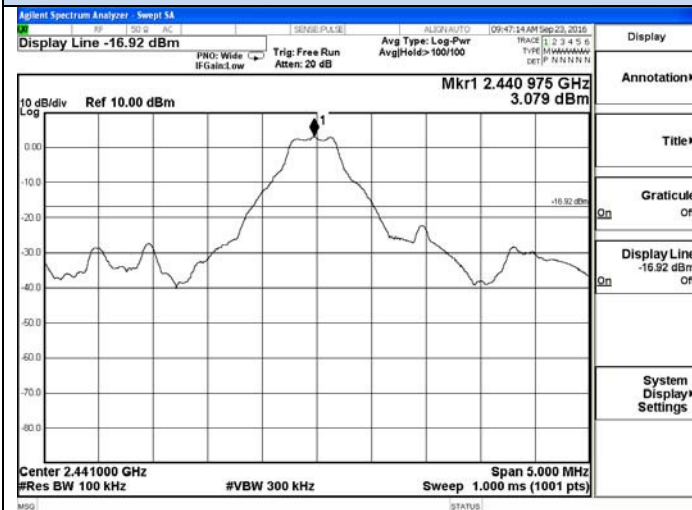

Reference of DH1-Middle channel

DH1-Middle channel

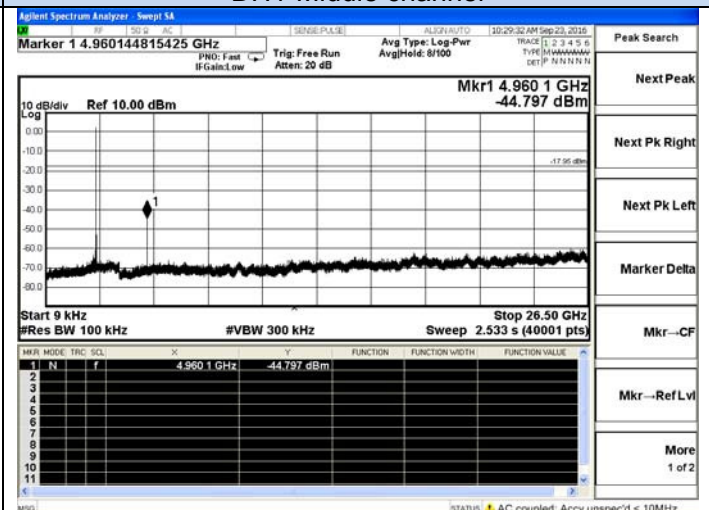
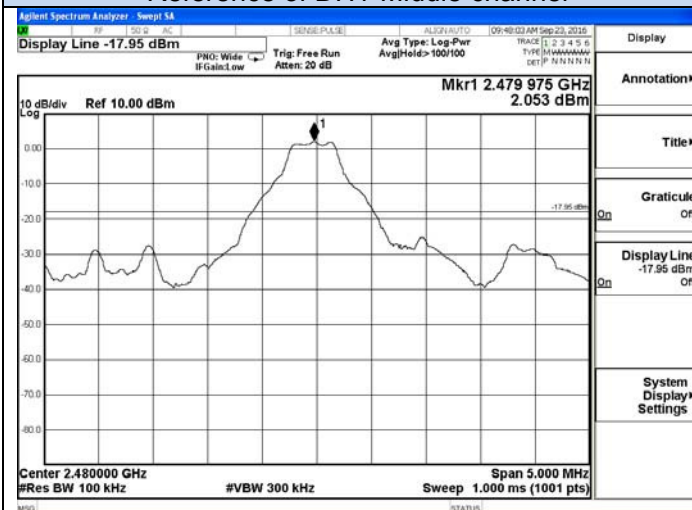

Reference of DH1-High channel

DH1-High channel

Test plot of Conducted Emission(9kHz~ 26.5GHz)

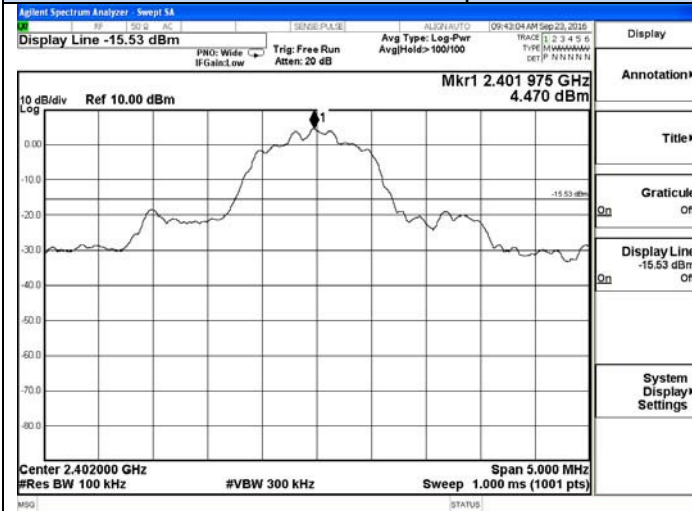

Reference of 2DH1-Low channel

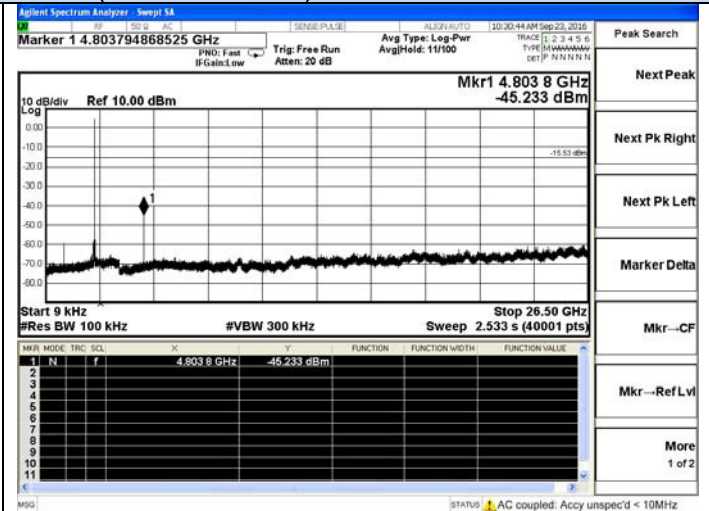

2DH1-Low channel

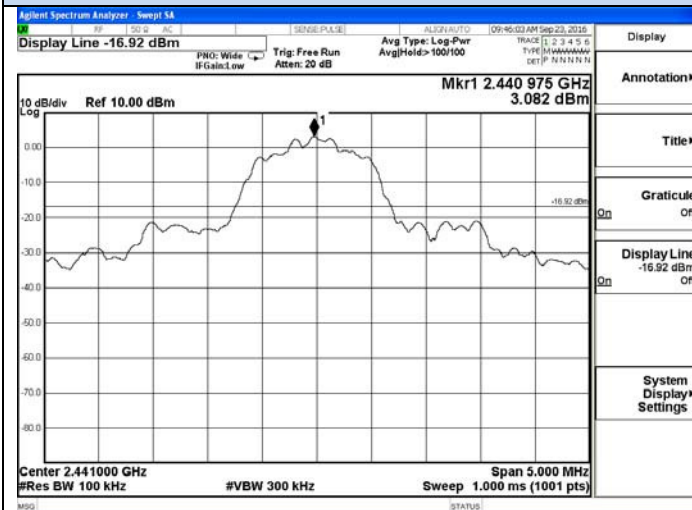

Reference of 2DH1-Middle channel

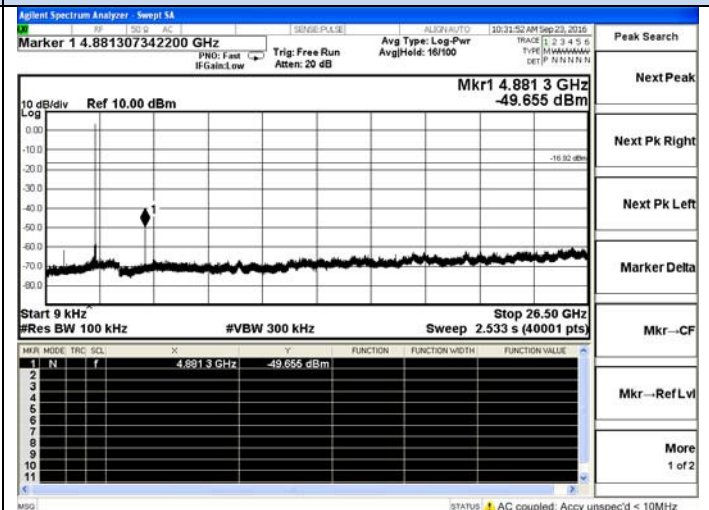

2DH1-Middle channel

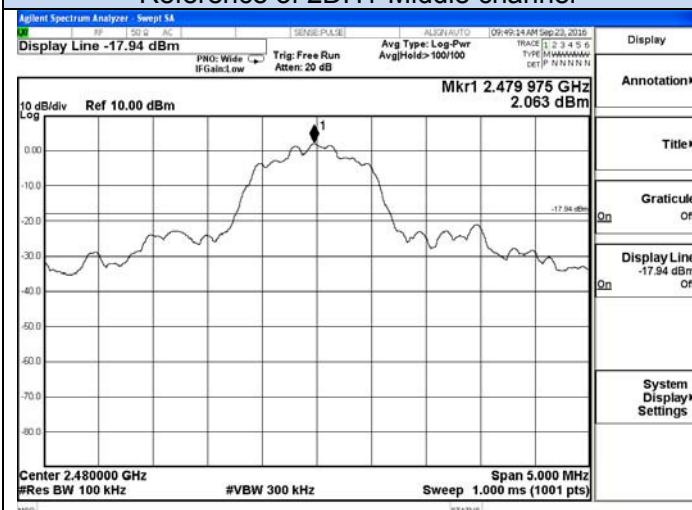

Reference of 2DH1-High channel

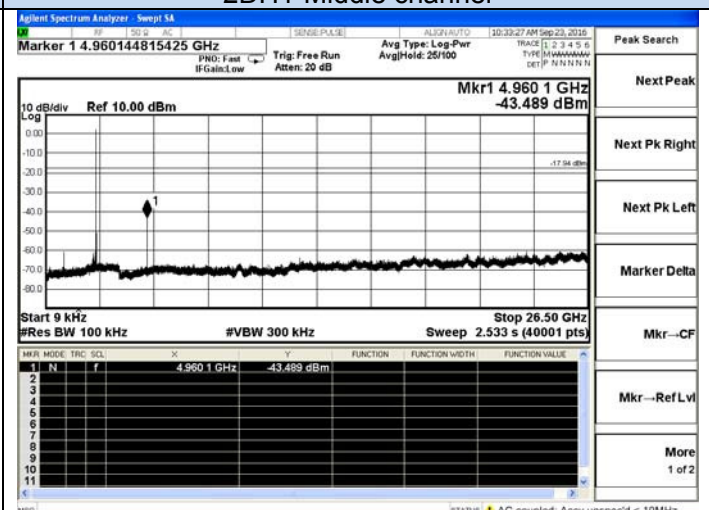

2DH1-High channel

Test plot of Conducted Emission(9kHz~ 26.5GHz)

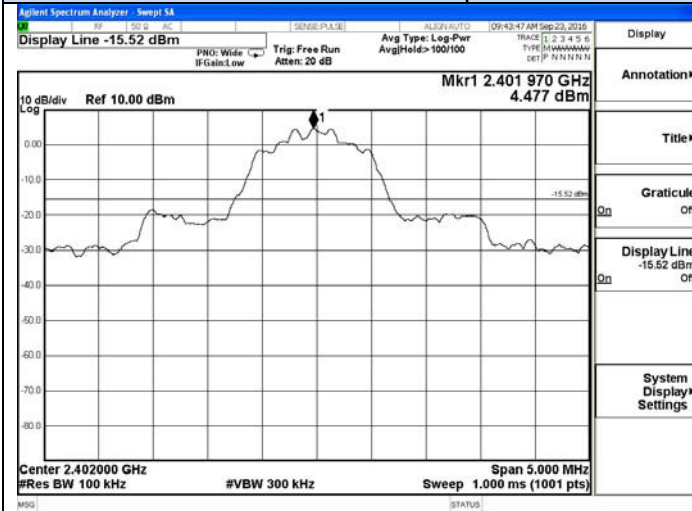

Reference of 3DH1-Low channel

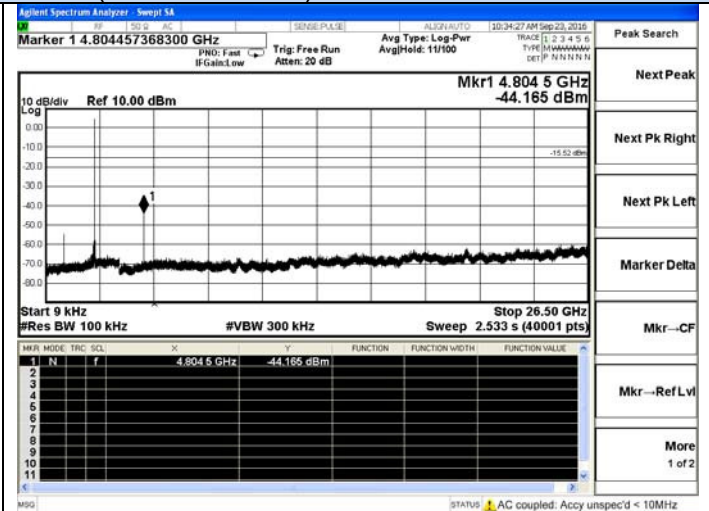

3DH1-Low channel

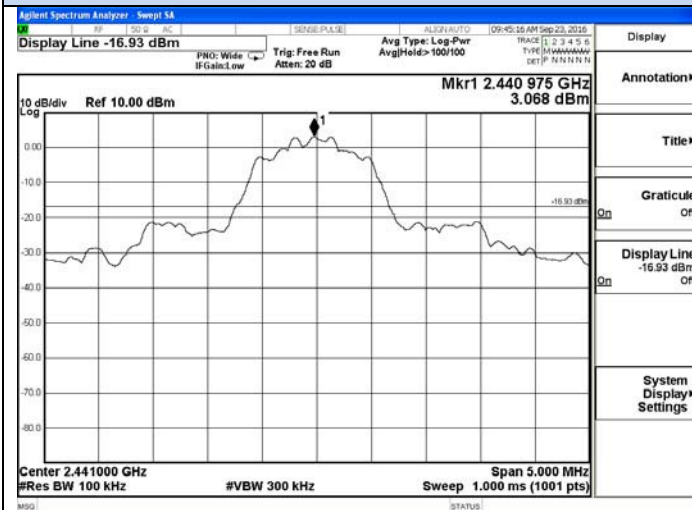

Reference of 3DH1-Middle channel

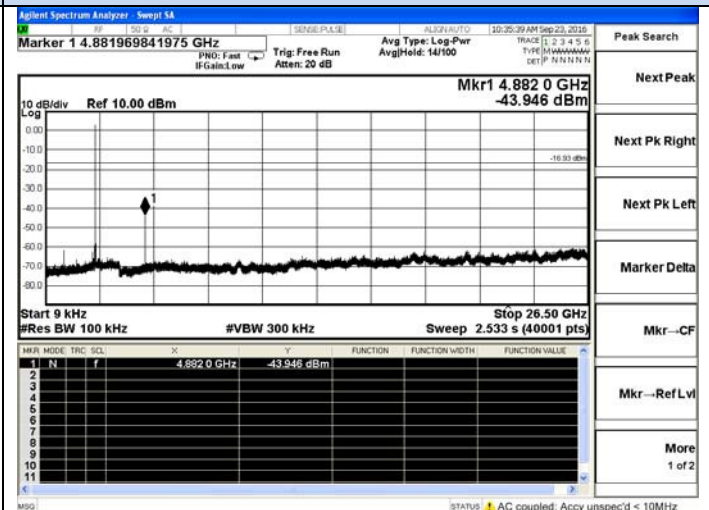

3DH1-Middle channel

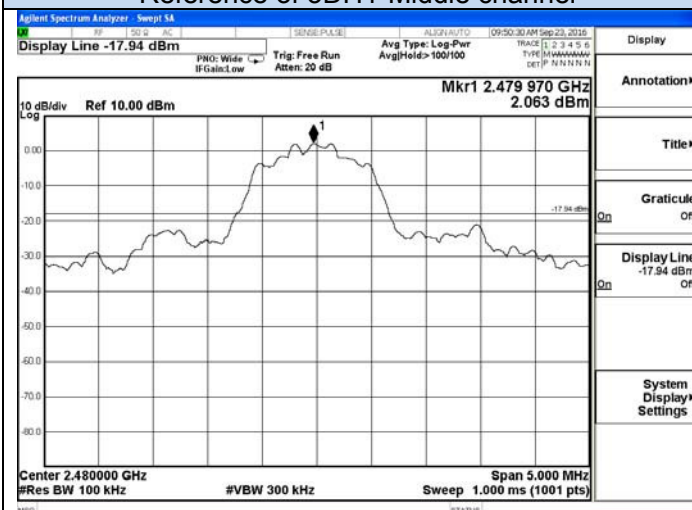

Reference of 3DH1-High channel

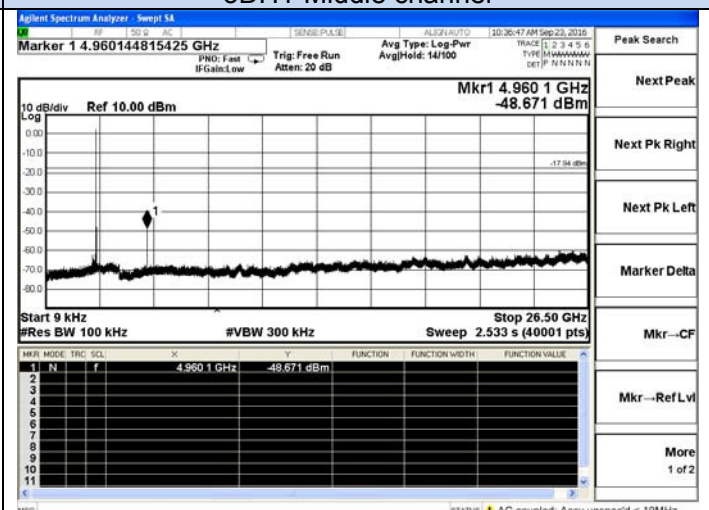

3DH1-High channel

6.5.5 Test Results of Band Edges Test

Test plot of Band Edges

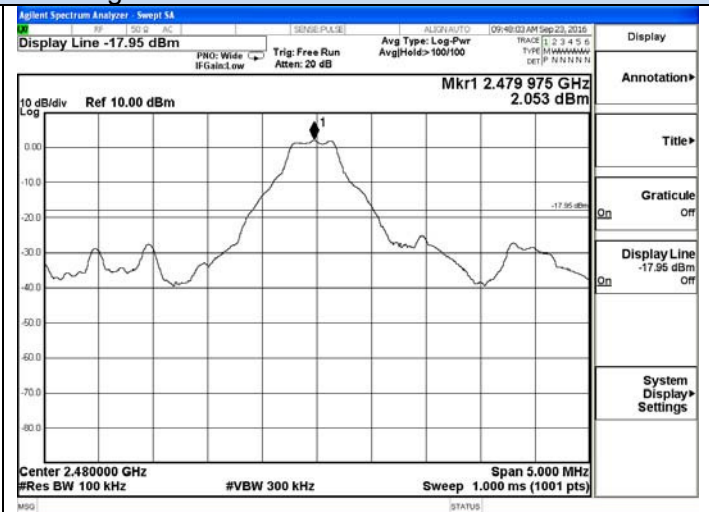
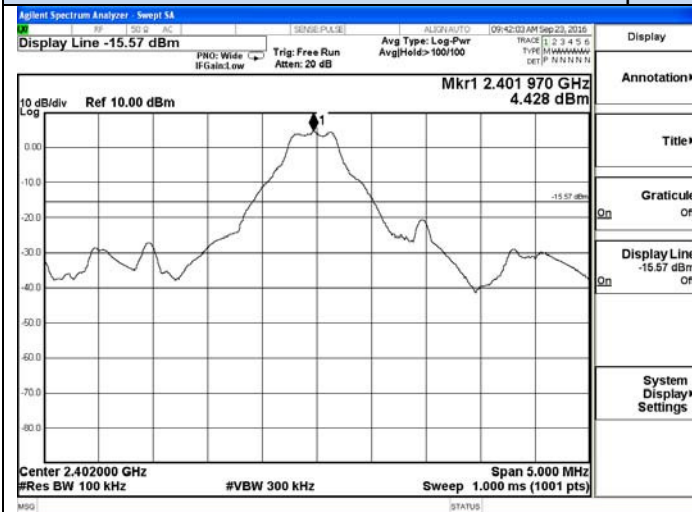

Reference of GFSK-Low channel

Reference of GFSK-High channel

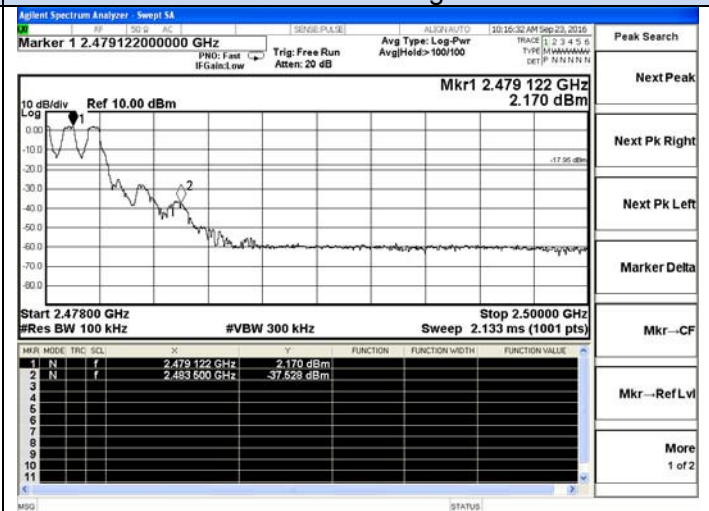
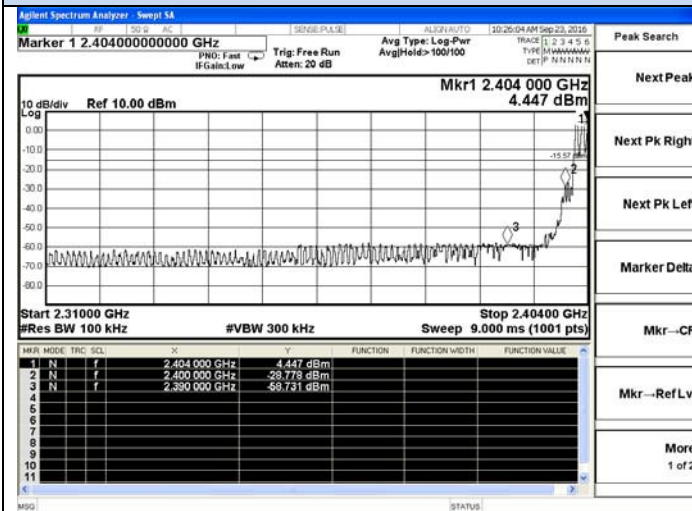

Hopping On-GFSK-Low channel

Hopping On-GFSK-High channel

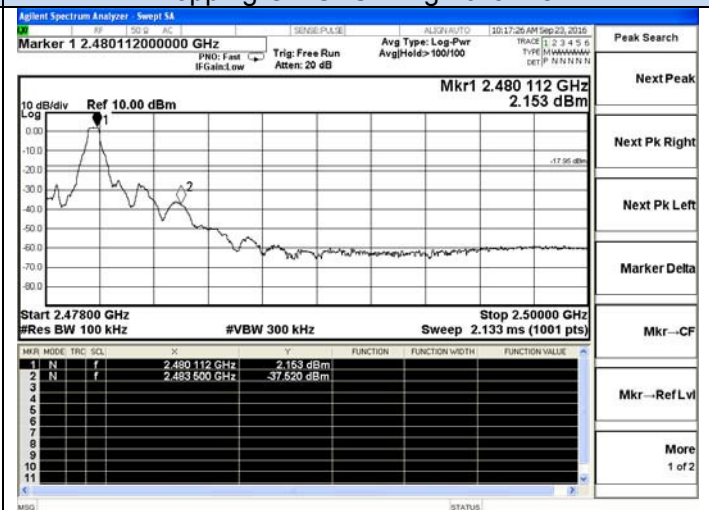
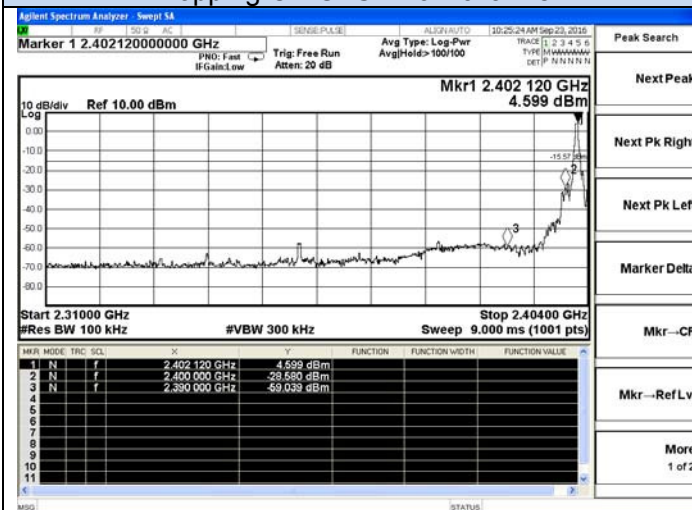

Hopping Off-GFSK-Low channel

Hopping Off-GFSK-High channel

Test plot of Band Edges

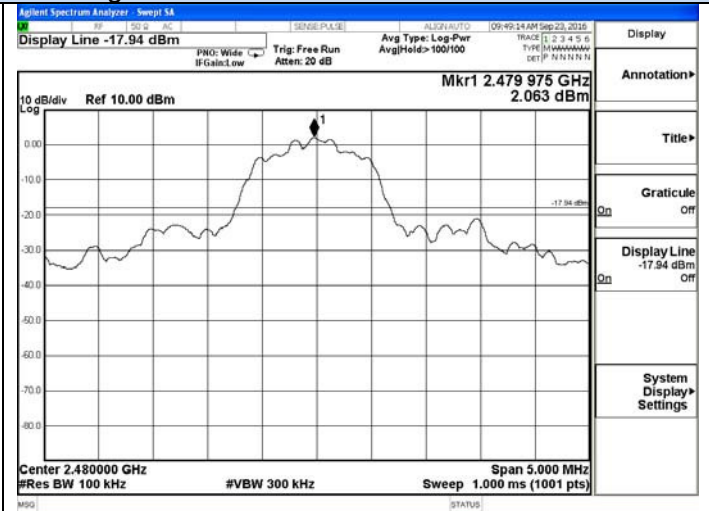
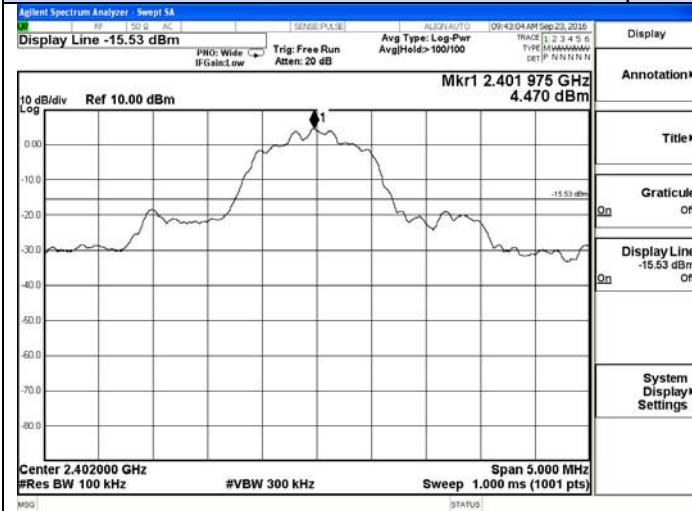

Reference of $\pi/4$ -DQPSK-Low channel

Reference of $\pi/4$ -DQPSK-High channel

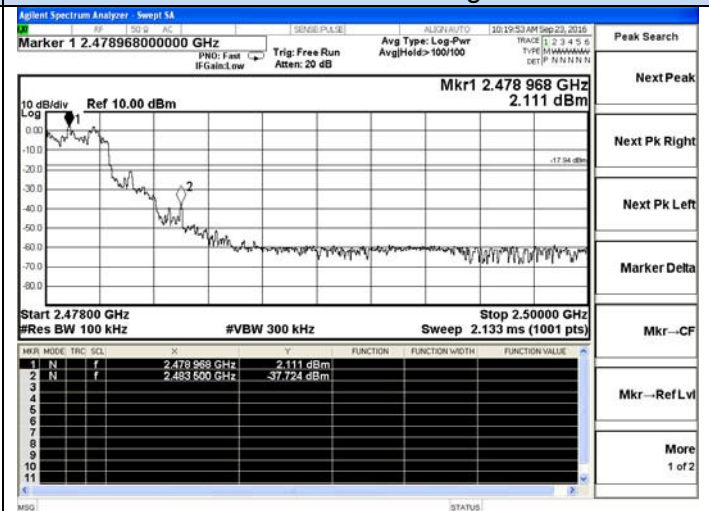
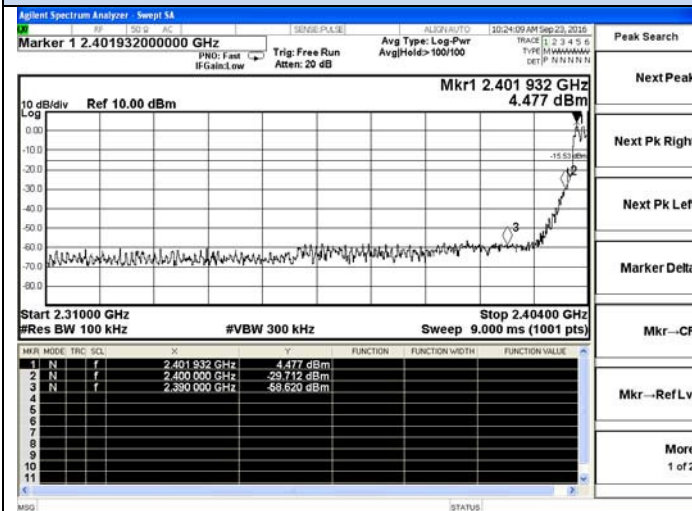

Hopping On- $\pi/4$ -DQPSK-Low channel

Hopping On- $\pi/4$ -DQPSK-High channel

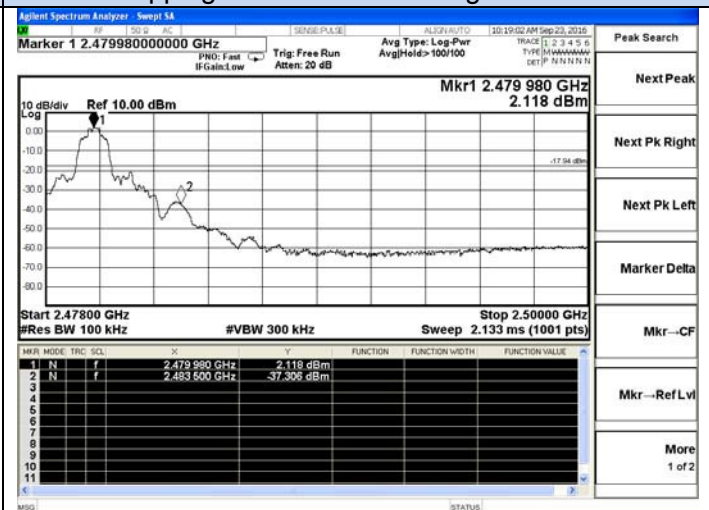

Hopping Off- $\pi/4$ -DQPSK-Low channel

Hopping Off- $\pi/4$ -DQPSK-High channel

Test plot of Band Edges

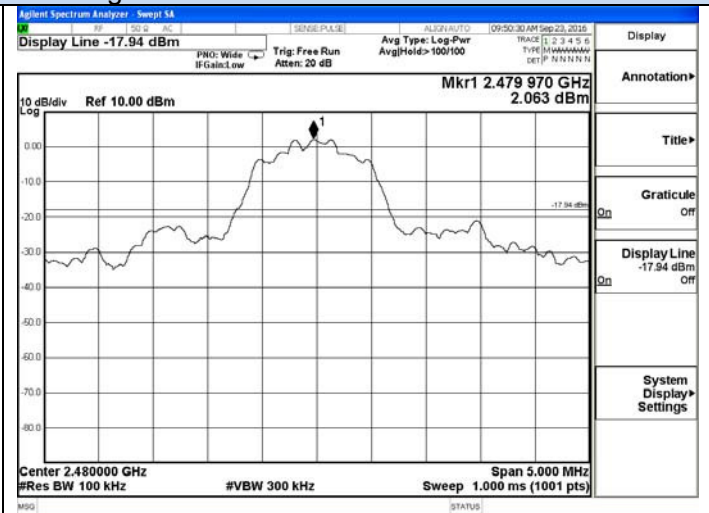
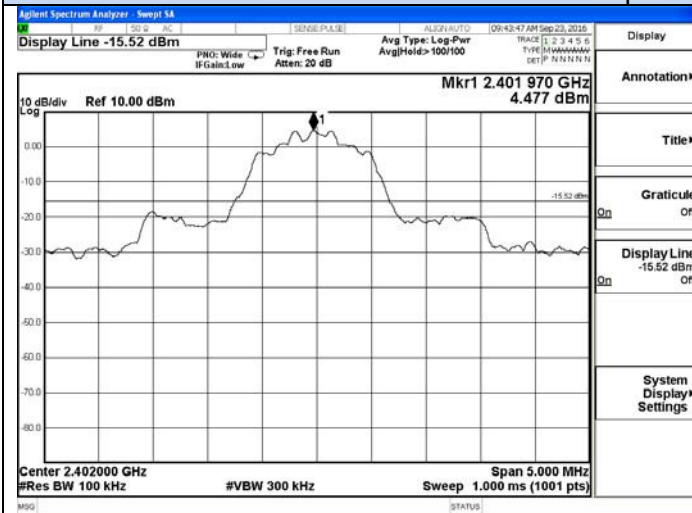

Reference of 8-DPSK-Low channel

Reference of 8-DPSK-High channel

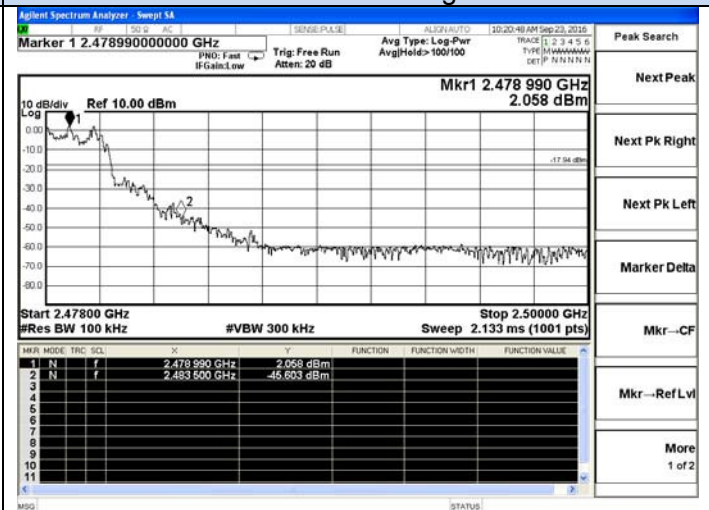
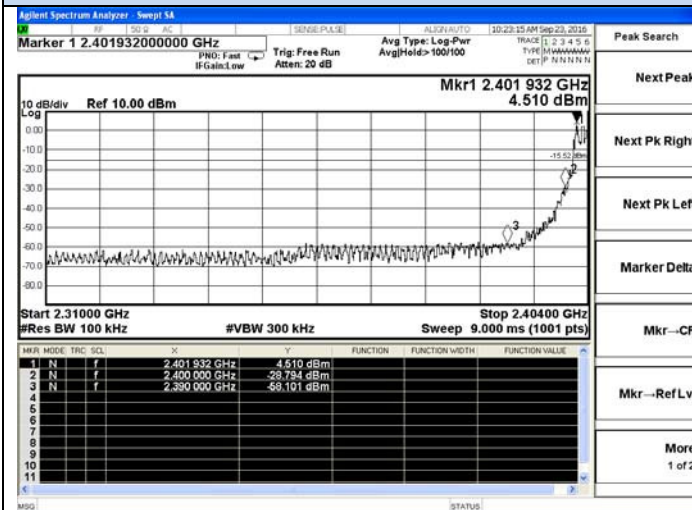

Hopping On-8-DPSK-Low channel

Hopping On-8-DPSK-High channel

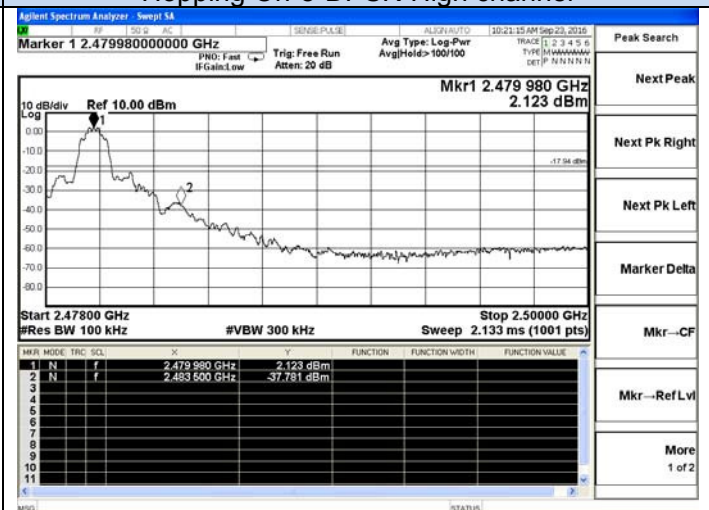
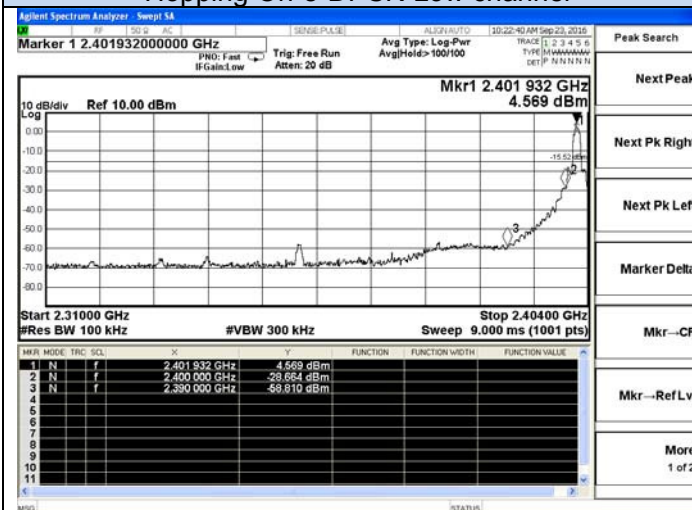

Hopping Off-8-DPSK-Low channel

Hopping Off-8-DPSK-High channel

7. RADIATED MEASUREMENT

7.1 Block Diagram of Test Setup

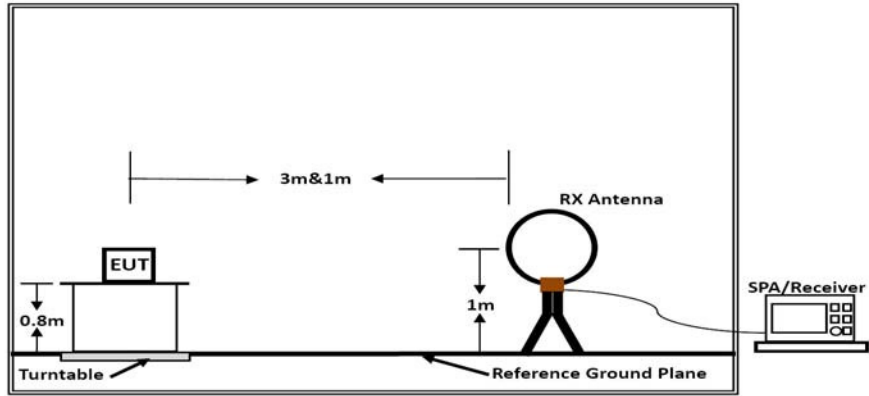

Below 30MHz

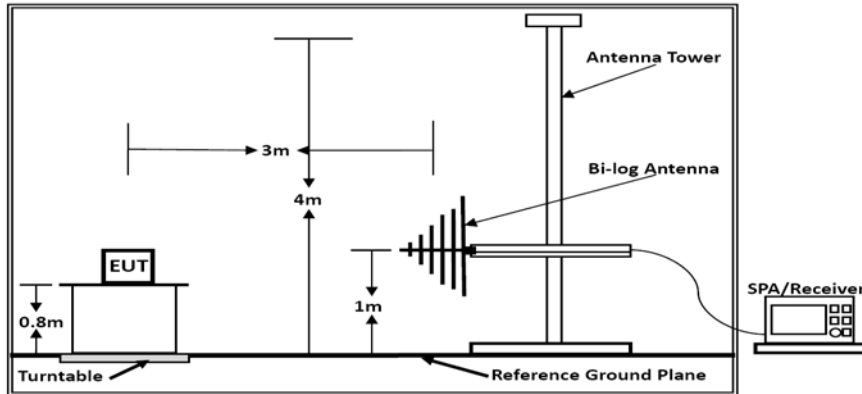

Below 1GHz

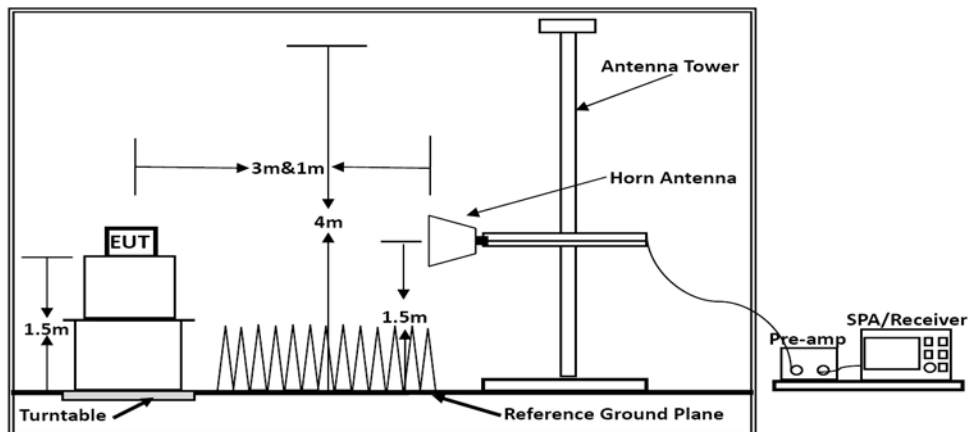

Above 1GHz

7.2 Restricted Band Emission Limit

15.205 (a) Except as shown in paragraph (d) of this section, only spurious emissions are permitted in any of the frequency bands listed below:

MHz	MHz	MHz	GHz
0.090-0.110	16.42-16.423	399.9-410	4.5-5.15
\1\ 0.495-0.505	16.69475-16.69525	608-614	5.35-5.46
2.1735-2.1905	16.80425-16.80475	960-1240	7.25-7.75
4.125-4.128	25.5-25.67	1300-1427	8.025-8.5
4.17725-4.17775	37.5-38.25	1435-1626.5	9.0-9.2
4.20725-4.20775	73-74.6	1645.5-1646.5	9.3-9.5
6.215-6.218	74.8-75.2	1660-1710	10.6-12.7
6.26775-6.26825	108-121.94	1718.8-1722.2	13.25-13.4
6.31175-6.31225	123-138	2200-2300	14.47-14.5
8.291-8.294	149.9-150.05	2310-2390	15.35-16.2
8.362-8.366	156.52475-156.52525	2483.5-2500	17.7-21.4
8.37625-8.38675	156.7-156.9	2690-2900	22.01-23.12
8.41425-8.41475	162.0125-167.17	3260-3267	23.6-24.0
12.29-12.293	167.72-173.2	3332-3339	31.2-31.8
12.51975-12.52025	240-285	3345.8-3358	36.43-36.5
12.57675-12.57725	322-335.4	3600-4400	(\2)
13.36-13.41			

\1\ Until February 1, 1999, this restricted band shall be 0.490-0.510 MHz.

\2\ Above 38.6

Part 15.205 (b) Except as provided in paragraphs (d) and (e), the field strength of emissions appearing within these frequency bands shall not exceed the limits shown in Section 15.209. At frequencies equal to or less than 1000 MHz, compliance with the limits in Section 15.209 shall be demonstrated using measurement instrumentation employing a CISPR quasi-peak detector.

Above 1000 MHz, compliance with the emission limits in Section 15.209 shall be demonstrated based on the average value of the measured emissions. The provisions in Section 15.35 apply to these measurements.

Part 15.209 (a) Except as provided elsewhere in this Subpart, the emissions from an intentional radiator shall not exceed the field strength levels specified in the following table:

Frequency (MHz)	Field strength (microvolts/meter)	Measurement distance (meters)
0.009-0.490	2400/F(kHz)	300
0.490-1.705	24000/F(kHz)	30
1.705-30.0	30	30
30-88	100**	3
88-216	150**	3
216-960	200**	3
Above 960	500	3

7.3 Instruments Setting

The following table is the setting of spectrum analyzer and receiver.

Spectrum Parameter	Setting
Attenuation	Auto
Start Frequency	1000 MHz
Stop Frequency	10th carrier harmonic
RB / VB (Emission in restricted band)	1MHz / 1MHz for Peak, 1 MHz / 20log(Dwell Time/100ms) kHz for Average
RB / VB (Emission in non-restricted band)	1MHz / 1MHz for Peak, 1 MHz / 20log(Dwell Time/100ms) kHz for Average

Receiver Parameter	Setting
Attenuation	Auto
Start ~ Stop Frequency	9kHz~150kHz / RB 200Hz for QP/AVG
Start ~ Stop Frequency	150kHz~30MHz / RB 9kHz for QP/AVG
Start ~ Stop Frequency	30MHz~1000MHz / RB 100kHz for QP

7.4 Test Procedures

1) Sequence of testing 9 kHz to 30 MHz

Setup:

- The equipment was set up to simulate a typical usage like described in the user manual or described by manufacturer.
- If the EUT is a tabletop system, a rotatable table with 0.8 m height is used.
- If the EUT is a floor standing device, it is placed on the ground.
- Auxiliary equipment and cables were positioned to simulate normal operation conditions.
- The AC power port of the EUT (if available) is connected to a power outlet below the turntable.
- The measurement distance is 3 meter.
- The EUT was set into operation.

Premeasurement:

- The turntable rotates from 0° to 315° using 45° steps.
- The antenna height is 0.8 meter.
- At each turntable position the analyzer sweeps with peak detection to find the maximum of all emissions

Final measurement:

- Identified emissions during the premeasurement the software maximizes by rotating the turntable position (0° to 360°) and by rotating the elevation axes (0° to 360°).
- The final measurement will be done in the position (turntable and elevation) causing the highest emissions with QPK detector.
- The final levels, frequency, measuring time, bandwidth, turntable position, correction factor, margin to the limit and limit will be recorded. Also a plot with the graph of the premeasurement and the limit will be stored.

2) Sequence of testing 30 MHz to 1 GHz

Setup:

- The equipment was set up to simulate a typical usage like described in the user manual or described by manufacturer.
- If the EUT is a tabletop system, a table with 0.8 m height is used, which is placed on the ground plane.
- If the EUT is a floor standing device, it is placed on the ground plane with insulation between both.
- Auxiliary equipment and cables were positioned to simulate normal operation conditions
- The AC power port of the EUT (if available) is connected to a power outlet below the turntable.
- The measurement distance is 3 meter.
- The EUT was set into operation.

Premeasurement:

- The turntable rotates from 0° to 315° using 45° steps.
- The antenna is polarized vertical and horizontal.
- The antenna height changes from 1 to 3 meter.
- At each turntable position, antenna polarization and height the analyzer sweeps three times in peak to find the maximum of all emissions.

Final measurement:

- The final measurement will be performed with minimum the six highest peaks.
- According to the maximum antenna and turntable positions of premeasurement the software maximize the peaks by changing turntable position ($\pm 45^\circ$) and antenna movement between 1 and 4 meter.
- The final measurement will be done with QP detector with an EMI receiver.
- The final levels, frequency, measuring time, bandwidth, antenna height, antenna polarization, turntable angle, correction factor, margin to the limit and limit will be recorded. Also a plot with the graph of the premeasurement with marked maximum final measurements and the limit will be stored.

3) Sequence of testing 1 GHz to 18 GHz

Setup:

- The equipment was set up to simulate a typical usage like described in the user manual or described by manufacturer.
- If the EUT is a tabletop system, a rotatable table with 1.5 m height is used.
- If the EUT is a floor standing device, it is placed on the ground plane with insulation between both.
- Auxiliary equipment and cables were positioned to simulate normal operation conditions
- The AC power port of the EUT (if available) is connected to a power outlet below the turntable.
- The measurement distance is 3 meter.
- The EUT was set into operation.

Premeasurement:

- The turntable rotates from 0° to 315° using 45° steps.
- The antenna is polarized vertical and horizontal.
- The antenna height scan range is 1 meter to 2.5 meter.
- At each turntable position and antenna polarization the analyzer sweeps with peak detection to find the maximum of all emissions.

Final measurement:

- The final measurement will be performed with minimum the six highest peaks.
- According to the maximum antenna and turntable positions of premeasurement the software maximize the peaks by changing turntable position ($\pm 45^\circ$) and antenna movement between 1 and 4 meter. This procedure is repeated for both antenna polarizations.
- The final measurement will be done in the position (turntable, EUT-table and antenna polarization) causing the highest emissions with Peak and Average detector.
- The final levels, frequency, measuring time, bandwidth, turntable position, EUT-table position, antenna polarization, correction factor, margin to the limit and limit will be recorded. Also a plot with the graph of the premeasurement with marked maximum final measurements and the limit will be stored.

4) Sequence of testing above 18 GHz

Setup:

- The equipment was set up to simulate a typical usage like described in the user manual or described by manufacturer.
- If the EUT is a tabletop system, a rotatable table with 1.5 m height is used.
- If the EUT is a floor standing device, it is placed on the ground plane with insulation between both.
- Auxiliary equipment and cables were positioned to simulate normal operation conditions
- The AC power port of the EUT (if available) is connected to a power outlet below the turntable.
- The measurement distance is 1 meter.
- The EUT was set into operation.

Premeasurement:

- The antenna is moved spherical over the EUT in different polarisations of the antenna.

Final measurement:

- The final measurement will be performed at the position and antenna orientation for all detected emissions that were found during the premeasurements with Peak and Average detector.
- The final levels, frequency, measuring time, bandwidth, correction factor, margin to the limit and limit will be recorded. Also a plot with the graph of the premeasurement and the limit will be stored.

7.5 Results for Restricted Band Radiated Emissions Testing

PASS.

Only record the worst test result in this report.

The test data please refer to following page.

Below 1GHz (Low Channel)

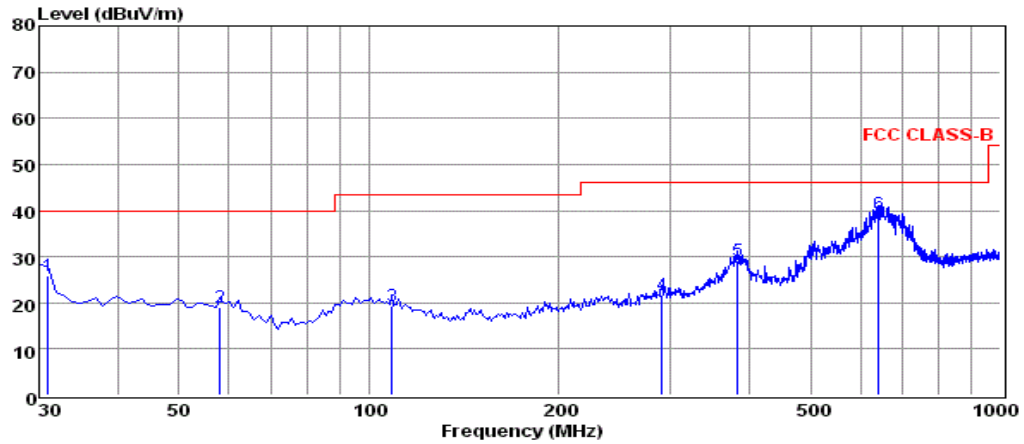

Env./Ins: 24°C/56%
 pol: HORIZONTAL

	Freq	Reading	CabLos	Antfac	Measured	Limit	Over	Remark
	MHz	dBuV	dB	dB/m	dBuV/m	dBuV/m	dB	
1	30.97	13.30	0.39	12.32	26.01	40.00	-13.99	QP
2	58.13	5.87	0.47	12.81	19.15	40.00	-20.85	QP
3	108.57	6.34	0.68	12.38	19.40	43.50	-24.10	QP
4	290.93	7.88	1.01	12.88	21.77	46.00	-24.23	QP
5	384.05	13.40	1.13	14.69	29.22	46.00	-16.78	QP
6	641.10	18.99	1.55	18.60	39.14	46.00	-6.86	QP

Note: 1. All readings are Quasi-peak values.
 2. Measured= Reading + Antenna Factor + Cable Loss
 3. The emission that ate 20db blow the official limit are not reported

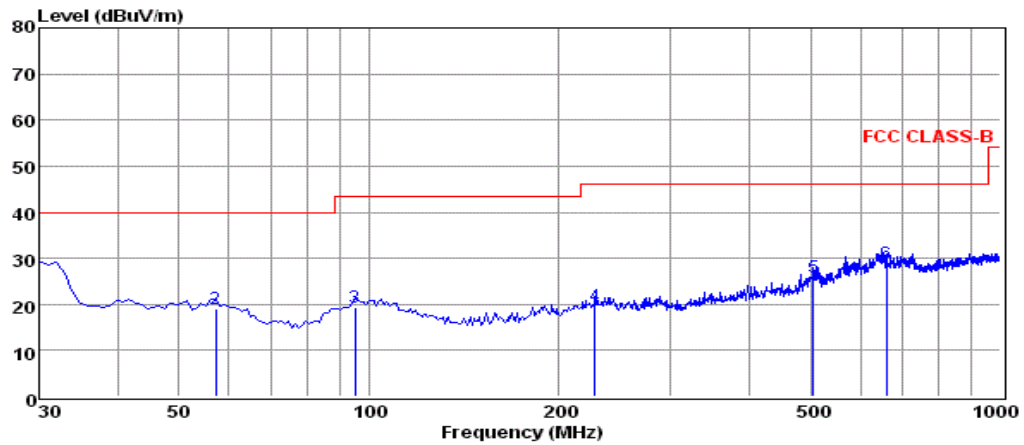

Env./Ins: 24°C/56%
 pol: VERTICAL

	Freq	Reading	CabLos	Antfac	Measured	Limit	Over	Remark
	MHz	dBuV	dB	dB/m	dBuV/m	dBuV/m	dB	
1	30.00	14.82	0.39	12.33	27.54	40.00	-12.46	QP
2	57.16	5.78	0.47	12.88	19.13	40.00	-20.87	QP
3	94.99	5.91	0.58	12.84	19.33	43.50	-24.17	QP
4	227.88	7.14	0.93	11.55	19.62	46.00	-26.38	QP
5	506.27	7.89	1.29	16.70	25.88	46.00	-20.12	QP
6	659.53	8.66	1.63	18.66	28.95	46.00	-17.05	QP

Note: 1. All readings are Quasi-peak values.
 2. Measured= Reading + Antenna Factor + Cable Loss
 3. The emission that ate 20db blow the official limit are not reported

Above 1GHz

The worst test result for GFSK, Tx-Low Channel:

Freq. MHz	Reading dBuv	Ant. Fac dB/m	Pre. Fac. dB	Cab. Loss dB	Measured dBuv/m	Limit dBuv/m	Margin dB	Remark	Pol.
4804.00	56.13	33.06	35.04	3.94	58.09	74	-15.91	Peak	Horizontal
4804.00	42.66	33.06	35.04	3.94	44.62	54	-9.38	Average	Horizontal
4804.00	52.62	33.06	35.04	3.94	54.58	74	-19.42	Peak	Vertical
4804.00	41.45	33.06	35.04	3.94	43.41	54	-10.59	Average	Vertical

The worst test result for GFSK, Tx-Middle Channel:

Freq. MHz	Reading dBuv	Ant. Fac dB/m	Pre. Fac. dB	Cab. Loss dB	Measured dBuv/m	Limit dBuv/m	Margin dB	Remark	Pol.
4882.00	56.12	33.16	35.15	3.96	58.09	74	-15.91	Peak	Horizontal
4882.00	43.00	33.16	35.15	3.96	44.97	54	-9.03	Average	Horizontal
4882.00	53.75	33.16	35.15	3.96	55.72	74	-18.28	Peak	Vertical
4882.00	41.16	33.16	35.15	3.96	43.13	54	-10.87	Average	Vertical

The worst test result for GFSK, Tx-High Channel:

Freq. MHz	Reading dBuv	Ant. Fac dB/m	Pre. Fac. dB	Cab. Los dB	Measured dBuv/m	Limit dBuv/m	Margin dB	Remark	Pol.
4960.00	56.45	33.26	35.14	3.98	58.55	74	-15.45	Peak	Horizontal
4960.00	42.89	33.26	35.14	3.98	44.99	54	-9.01	Average	Horizontal
4960.00	54.08	33.26	35.14	3.98	56.18	74	-17.82	Peak	Vertical
4960.00	40.38	33.26	35.14	3.98	42.48	54	-11.52	Average	Vertical

Notes:

- 1). Measuring frequencies from 9k~10th harmonic (ex. 26GHz), No emission found between lowest internal used/generated frequency to 30 MHz.
- 2). Radiated emissions measured in frequency range from 9k~10th harmonic (ex. 26GHz) were made with an instrument using Peak detector mode.
- 3). 18~25GHz at least have 20dB margin. No recording in the test report.

7.6 Results for Restricted Band edge Testing

Tx-2402, GFSK, Non-hopping

Freq. MHz	Reading Level dBuV	Ant. Fac. dB/m	Pre. Fac. dB	Cab. Loss dB	Measured dBuV/m	Limit dBuV/m	Margin dB	Remark	Pol.
2390.00	50.25	32.89	35.16	3.51	51.49	74	-22.51	Peak	Horizontal
2390.00	35.30	32.89	35.16	3.51	36.55	54	-17.45	Average	Horizontal
2400.00	55.04	32.92	35.16	3.54	56.34	74	-17.66	Peak	Horizontal
2400.00	38.25	32.92	35.16	3.54	39.55	54	-14.45	Average	Horizontal
2390.00	49.02	32.89	35.16	3.51	50.26	74	-23.74	Peak	Vertical
2390.00	35.08	32.89	35.16	3.51	36.33	54	-17.67	Average	Vertical
2400.00	51.61	32.92	35.16	3.54	52.91	74	-21.09	Peak	Vertical
2400.00	36.66	32.92	35.16	3.54	37.96	54	-16.04	Average	Vertical

Tx-2480, GFSK, Non-hopping

Freq. MHz	Reading Level dBuV	Ant. Fac. dB/m	Pre. Fac. dB	Cab. Loss dB	Measured dBuV/m	Limit dBuV/m	Margin dB	Remark	Pol.
2483.50	52.61	33.06	35.18	3.60	54.09	74	-19.91	Peak	Horizontal
2483.50	38.88	33.06	35.18	3.60	40.36	54	-13.64	Average	Horizontal
2483.50	50.74	33.06	35.18	3.60	52.22	74	-21.78	Peak	Vertical
2483.50	36.65	33.06	35.18	3.60	38.13	54	-15.87	Average	Vertical

Note:

- 1). All modes have been tested and we only record the worst test result;

7.7. Power line conducted emissions

7.7.1 Standard Applicable

According to §15.207 (a): For an intentional radiator which is designed to be connected to the public utility (AC) power line, the radio frequency voltage that is conducted back onto the AC power line on any frequency or frequencies within the band 150 kHz to 30 MHz shall not exceed 250 microvolts (The limit decreases linearly with the logarithm of the frequency in the range 0.15 MHz to 0.50 MHz). The limits at specific frequency range is listed as follows:

Frequency Range (MHz)	Limits (dB μ V)	
	Quasi-peak	Average
0.15 to 0.50	66 to 56	56 to 46
0.50 to 5	56	46
5 to 30	60	50

7.7.2 Block Diagram of Test Setup

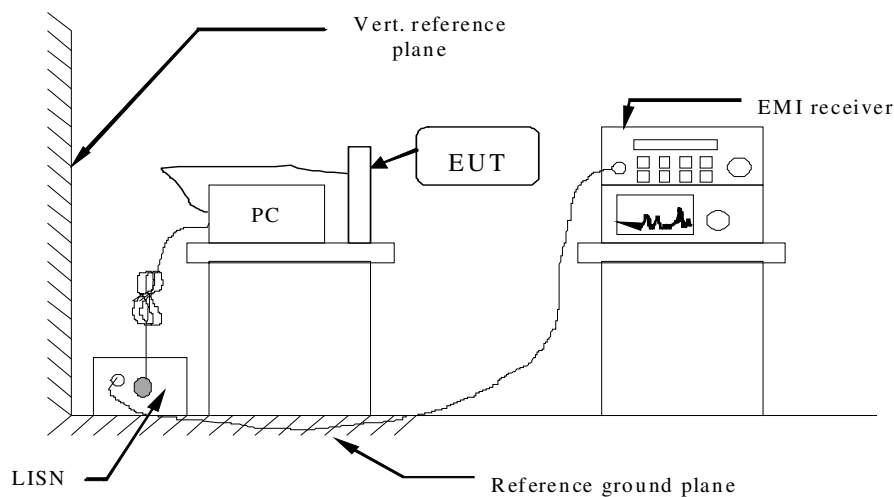

7.7.3 Test Results

PASS.

The test data please refer to following page.

Test result for GFSK-AC 120V

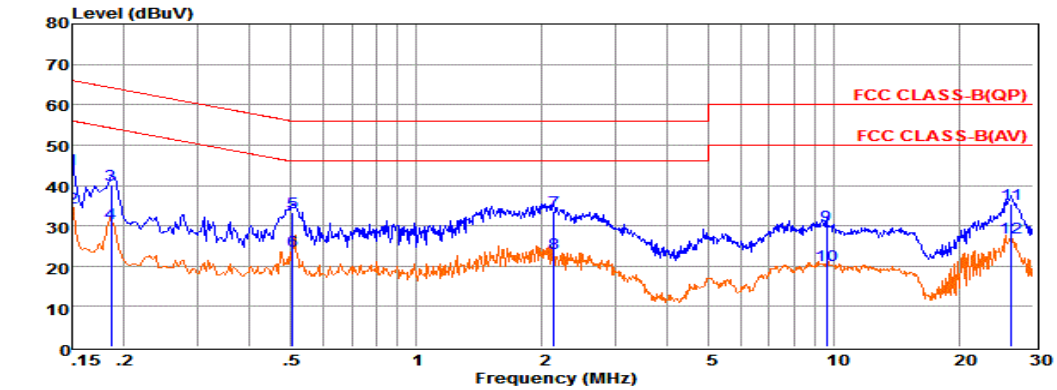

Env. Ins: 24*/56%
 Power Rating: AC 120V/60Hz
 Pol: NEUTRAL

	Freq	Reading	LISNFac	CabLos	Measured	Limit	Over	Remark
	MHz	dBuV	dB	dB	dBuV	dBuV	dB	
1	0.15	24.31	9.70	0.02	44.03	66.00	-21.97	QP
2	0.15	14.79	9.70	0.02	34.51	55.99	-21.48	Average
3	0.19	20.57	9.62	0.02	40.21	64.20	-23.99	QP
4	0.19	11.14	9.62	0.02	30.78	54.19	-23.41	Average
5	0.50	13.76	9.62	0.04	33.42	56.00	-22.58	QP
6	0.50	4.19	9.62	0.04	23.85	46.00	-22.15	Average
7	2.13	13.99	9.63	0.05	33.67	56.00	-22.33	QP
8	2.13	3.42	9.63	0.05	23.10	46.00	-22.90	Average
9	9.60	10.37	9.72	0.08	30.17	60.00	-29.83	QP
10	9.60	0.56	9.72	0.08	20.36	50.00	-29.64	Average
11	26.56	15.52	9.83	0.13	35.48	60.00	-24.52	QP
12	26.56	7.00	9.83	0.13	26.96	50.00	-23.04	Average

Remarks: 1. Measured = Reading +Cable Loss.
 2. The emission levels that are 20dB below the official limit are not reported.

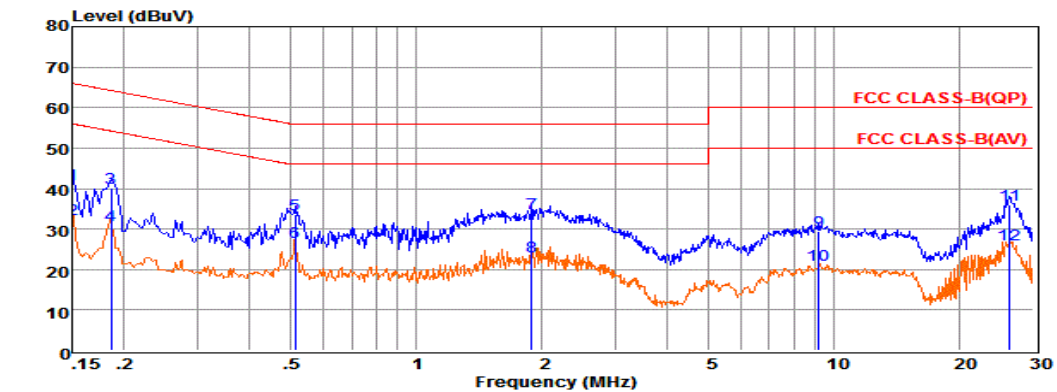

Env. Ins: 24*/56%
 Power Rating: AC 120V/60Hz
 Pol: LINE

	Freq	Reading	LISNFac	CabLos	Measured	Limit	Over	Remark
	MHz	dBuV	dB	dB	dBuV	dBuV	dB	
1	0.15	21.57	9.57	0.02	41.16	66.00	-24.84	QP
2	0.15	12.72	9.57	0.02	32.31	55.99	-23.68	Average
3	0.19	20.58	9.62	0.02	40.22	64.20	-23.98	QP
4	0.19	11.18	9.62	0.02	30.82	54.19	-23.37	Average
5	0.51	14.05	9.62	0.04	33.71	56.00	-22.29	QP
6	0.51	7.06	9.62	0.04	26.72	46.00	-19.28	Average
7	1.89	14.13	9.64	0.05	33.82	56.00	-22.18	QP
8	1.89	3.46	9.64	0.05	23.15	46.00	-22.85	Average
9	9.20	9.65	9.69	0.08	29.42	60.00	-30.58	QP
10	9.21	1.25	9.69	0.08	21.02	50.00	-28.98	Average
11	26.28	16.22	9.71	0.13	36.06	60.00	-23.94	QP
12	26.28	6.47	9.71	0.13	26.31	50.00	-23.69	Average

Remarks: 1. Measured = Reading +Cable Loss.
 2. The emission levels that are 20dB below the official limit are not reported.

Test result for GFSK-AC 240V

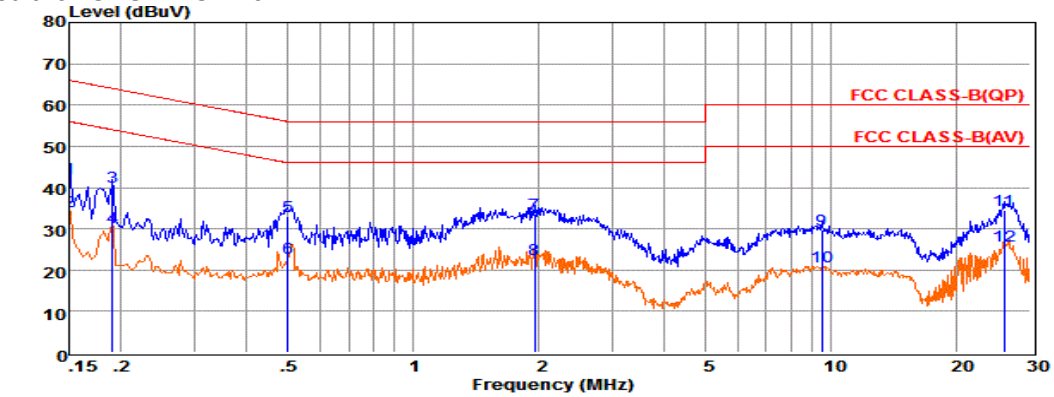

Env. Ins: 24*/56%
 Power Rating: AC 240V/60Hz
 Pol: LINE

	Freq	Reading	LISNFac	CabLos	Measured	Limit	Over	Remark
	MHz	dBuV	dB	dB	dBuV	dBuV	dB	
1	0.15	22.52	9.57	0.02	42.11	66.00	-23.89	QP
2	0.15	14.48	9.57	0.02	34.07	55.99	-21.92	Average
3	0.19	20.42	9.62	0.02	40.06	64.02	-23.96	QP
4	0.19	10.70	9.62	0.02	30.34	54.02	-23.68	Average
5	0.50	13.37	9.62	0.04	33.03	56.00	-22.97	QP
6	0.50	3.35	9.62	0.04	23.01	46.00	-22.99	Average
7	1.95	13.92	9.64	0.05	33.61	56.00	-22.39	QP
8	1.95	2.82	9.64	0.05	22.51	46.00	-23.49	Average
9	9.50	10.03	9.69	0.08	29.80	60.00	-30.20	QP
10	9.50	1.04	9.69	0.08	20.81	50.00	-29.19	Average
11	26.00	14.74	9.71	0.13	34.58	60.00	-25.42	QP
12	26.00	6.07	9.71	0.13	25.91	50.00	-24.09	Average

Remarks: 1. Measured = Reading +Cable Loss.
 2. The emission levels that are 20dB below the official limit are not reported.

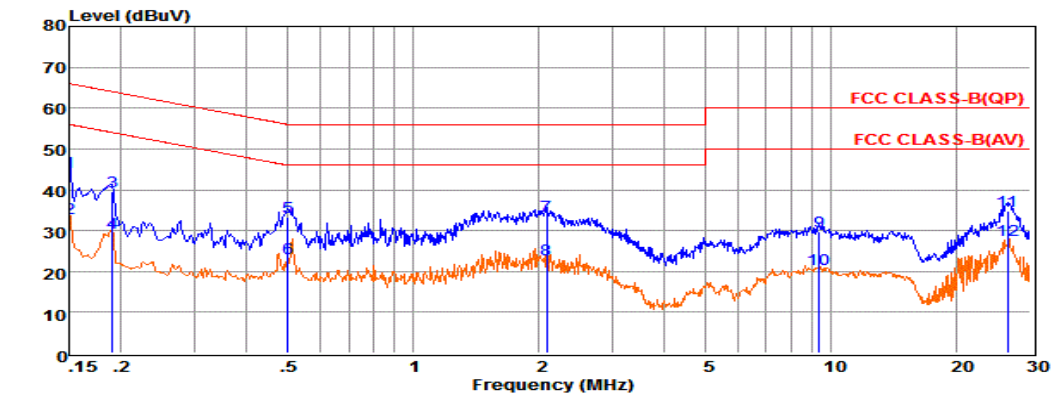

Env. Ins: 24*/56%
 Power Rating: AC 240V/60Hz
 Pol: NEUTRAL

	Freq	Reading	LISNFac	CabLos	Measured	Limit	Over	Remark
	MHz	dBuV	dB	dB	dBuV	dBuV	dB	
1	0.15	24.62	9.70	0.02	44.34	66.00	-21.66	QP
2	0.15	13.34	9.70	0.02	33.06	55.99	-22.93	Average
3	0.19	19.81	9.61	0.02	39.44	64.02	-24.58	QP
4	0.19	9.72	9.61	0.02	29.35	54.02	-24.67	Average
5	0.50	13.72	9.62	0.04	33.38	56.00	-22.62	QP
6	0.50	3.62	9.62	0.04	23.28	46.00	-22.72	Average
7	2.09	13.99	9.63	0.05	33.67	56.00	-22.33	QP
8	2.09	3.12	9.63	0.05	22.80	46.00	-23.20	Average
9	9.35	9.81	9.71	0.08	29.60	60.00	-30.40	QP
10	9.35	0.76	9.71	0.08	20.55	50.00	-29.45	Average
11	26.42	14.80	9.83	0.13	34.76	60.00	-25.24	QP
12	26.42	7.69	9.83	0.13	27.65	50.00	-22.35	Average

Remarks: 1. Measured = Reading +Cable Loss.
 2. The emission levels that are 20dB below the official limit are not reported.

8. ANTENNA REQUIREMENT

8.1 Standard Applicable

According to antenna requirement of §15.203.

An intentional radiator shall be designed to ensure that no antenna other than that furnished by the responsible party shall be used with the device. The use of a permanently attached antenna or of an antenna that uses a unique coupling to the intentional radiator shall be considered sufficient to comply with the provisions of this Section. The manufacturer may design the unit so that a broken antenna can be re-placed by the user, but the use of a standard antenna jack or electrical connector is prohibited. This requirement does not apply to carrier current devices or to devices operated under the provisions of Sections 15.211, 15.213, 15.217, 15.219, or 15.221. Further, this requirement does not apply to intentional radiators that must be professionally installed, such as perimeter protection systems and some field disturbance sensors, or to other intentional radiators which, in accordance with Section 15.31(d), must be measured at the installation site. However, the installer shall be responsible for ensuring that the proper antenna is employed so that the limits in this Part are not exceeded.

And according to §15.247(4)(1), system operating in the 2400-2483.5MHz bands that are used exclusively for fixed, point-to-point operations may employ transmitting antennas with directional gain greater than 6dBi provided the maximum peak output power of the intentional radiator is reduced by 1 dB for every 3 dB that the directional gain of the antenna exceeds 6dBi.

8.2 Antenna Connected Construction

8.2.1. Standard Applicable

According to § 15.203 & RSS-Gen, an intentional radiator shall be designed to ensure that no antenna other than that furnished by the responsible party shall be used with the device.

8.2.2. Antenna Connector Construction

The directional gains of antenna used for transmitting is 0.5dBi, and the antenna is an PCB Antenna connect to PCB board and no consideration of replacement. Please see EUT photo for details.

8.2.3. Results: Compliance.

Measurement

The antenna gain of the complete system is calculated by the difference of radiated power in EIRP and the conducted power of the module.

Conducted power refers ANSI C63.10:2013 Output power test procedure for DSS devices.

Radiated power refers to ANSI C63.10:2013 Radiated emissions tests.

Measurement parameters

Measurement parameter	
Detector:	Peak
Sweep Time:	Auto
Resolution bandwidth:	1MHz
Video bandwidth:	3MHz
Trace-Mode:	Max hold

Limits

FCC	IC
Antenna Gain	
6 dBi	

Note: The antenna gain of the complete system is calculated by the difference of radiated power in EIRP and the conducted power of the module. For Bluetooth 3.0 devices, the FHSS mode is used;

T_{nom}	V_{nom}	Lowest Channel 2402 MHz	Middle Channel 2441 MHz	Highest Channel 2480 MHz
Conducted power [dBm] Measured with GFSK modulation		3.501	3.411	3.497
Radiated power [dBm] Measured with GFSK modulation		3.851	3.821	3.877
Gain [dBi] Calculated		0.35	0.41	0.38
Measurement uncertainty			± 1.6 dB (cond.) / ± 3.8 dB (rad.)	

9. TEST SETUP PHOTOGRAPHS OF EUT

Please refer to separated files for Test Setup Photos of the EUT.

10. EXTERIOR PHOTOGRAPHS OF THE EUT

Please refer to separated files for External Photos of the EUT.

11. INTERIOR PHOTOGRAPHS OF THE EUT

Please refer to separated files for Internal Photos of the EUT.

-----THE END OF REPORT-----