

FCC TEST REPORT

For

South Surveying & Mapping Technology Co., Ltd.

GNSS RECEIVER

Test Model: K5

List Model No.: Please refer to page 6

Prepared for : South Surveying & Mapping Technology Co., Ltd.
Address : No.39, Sicheng Road, Tianhe District, Guangzhou, China

Prepared by : Shenzhen LCS Compliance Testing Laboratory Ltd.
Address : 1/F., Xingyuan Industrial Park, Tongda Road, Bao'an Avenue,
Bao'an District, Shenzhen, Guangdong, China

Tel : (+86)755-82591330
Fax : (+86)755-82591332
Web : www.LCS-cert.com
Mail : webmaster@LCS-cert.com

Date of receipt of test sample : March 06, 2019
Number of tested samples : 1
Serial number : Prototype
Date of Test : March 06, 2019~April 25, 2019
Date of Report : April 26, 2019

**FCC TEST REPORT
FCC Part 90**

Report Reference No. : **LCS190306002AEG**

Date of Issue : April 26, 2019

Testing Laboratory Name : **Shenzhen LCS Compliance Testing Laboratory Ltd.**

Address : 1/F., Xingyuan Industrial Park, Tongda Road, Bao'an Avenue,
Bao'an District, Shenzhen, Guangdong, China

Testing Location/ Procedure : Full application of Harmonised standards
Partial application of Harmonised standards
Other standard testing method

Applicant's Name : **South Surveying & Mapping Technology Co., Ltd.**

Address : No.39, Sicheng Road, Tianhe District, Guangzhou, China

Test Specification

Standard : FCC Part 2
FCC Part 90

Test Report Form No. : LCSEMC-1.0

TRF Originator : Shenzhen LCS Compliance Testing Laboratory Ltd.

Master TRF : Dated 2011-03

Shenzhen LCS Compliance Testing Laboratory Ltd. All rights reserved.

This publication may be reproduced in whole or in part for non-commercial purposes as long as the Shenzhen LCS Compliance Testing Laboratory Ltd. is acknowledged as copyright owner and source of the material. Shenzhen LCS Compliance Testing Laboratory Ltd. takes no responsibility for and will not assume liability for damages resulting from the reader's interpretation of the reproduced material due to its placement and context.

Test Item Description..... : **GNSS RECEIVER**

Trade Mark : SOUTH, KOLIDA, SANDING, RUIDE, TIANYU

Test Model : K5

Ratings : DC 7.4V by Rechargeable Li-ion Battery(3400mAh) or
DC 13.8V by external power
Recharged by DC 4.2V 1.35A or DC 8.4V/0.67A for battery

Result : **Positive**

Compiled by:



Aking Jin/ File administrator

Supervised by:

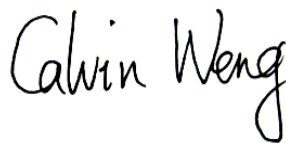

Calvin Weng/ Technique principal

Approved by:



Gavin Liang/ Manager

RADIO -- TEST REPORT

Test Report No. : LCS190306002AEG	<u>April 26, 2019</u> Date of issue
--	--

Test Model.....	: K5
EUT.....	: GNSS RECEIVER
Applicant.....	: South Surveying & Mapping Technology Co., Ltd.
Address.....	: No.39, Sicheng Road, Tianhe District, Guangzhou, China
Telephone.....	: /
Fax.....	: /
Manufacturer.....	: South Surveying & Mapping Technology Co., Ltd.
Address.....	: No.39, Sicheng Road, Tianhe District, Guangzhou, China
Telephone.....	: /
Fax.....	: /
Factory.....	: South Surveying & Mapping Technology Co., Ltd.
Address.....	: No.39, Sicheng Road, Tianhe District, Guangzhou, China
Telephone.....	: /
Fax.....	: /

Test Result	Positive
--------------------	-----------------

The test report merely corresponds to the test sample.

It is not permitted to copy extracts of these test result without the written permission of the test laboratory.

Revision History

Revision	Issue Date	Revisions	Revised By
000	April 26, 2019	Initial Issue	Gavin Liang

TABLE OF CONTENTS

Test Report Description	Page
1.GENERAL INFORMATION.....	6
1.1. DESCRIPTION OF DEVICE (EUT).....	6
1.2. HOST SYSTEM CONFIGURATION LIST AND DETAILS.....	7
1.3. EXTERNAL I/O CABLE.....	7
1.4. DESCRIPTION OF TEST FACILITY.....	7
1.5. STATEMENT OF THE MEASUREMENT UNCERTAINTY.....	7
1.6. MEASUREMENT UNCERTAINTY.....	7
1.7. DESCRIPTION OF TEST MODES.....	8
2.SYSTEM TEST CONFIGURATION.....	9
2.1. TEST STANDARDS.....	9
2.2. EUT CONFIGURATION.....	9
2.3. EUT EXERCISE.....	9
2.4. GENERAL TEST PROCEDURES.....	9
2.4.1 Conducted Emissions.....	9
2.4.2 Radiated Emissions.....	9
2.5. TEST SAMPLE.....	9
3.SYSTEM TEST CONFIGURATION.....	10
3.1. JUSTIFICATION.....	10
3.2. EUT EXERCISE SOFTWARE.....	10
3.3. SPECIAL ACCESSORIES.....	10
3.4. BLOCK DIAGRAM/SCHEMATICS.....	10
3.5. EQUIPMENT MODIFICATIONS.....	10
3.6. TEST SETUP.....	10
4.SUMMARY OF TEST RESULT.....	11
5.TEST CONDITIONS AND RESULTS.....	12
5.1. MAXIMUM TRANSMITTER POWER.....	12
5.2. OCCUPIED BANDWIDTH AND EMISSION MASK TEST.....	15
5.3. TRANSMITTER RADIATED SPURIOUS EMISSION.....	20
5.4. SPURIOUS EMISSION ON ANTENNA PORT.....	25
5.5. MODULATION CHARACTERISTICS - MODULATION LIMITING [§ 2.1047 (B)].....	33
5.6. FREQUENCY STABILITY TEST.....	34
5.7. TRANSMITTER FREQUENCY BEHAVIOR.....	36
6.LIST OF MEASURING EQUIPMENT.....	38
7.TEST SETUP PHOTOGRAPHS OF EUT.....	39
8.EXTERIOR PHOTOGRAPHS OF THE EUT.....	39
9.INTERIOR PHOTOGRAPHS OF THE EUT.....	39

1. GENERAL INFORMATION

1.1. Description of Device (EUT)

Name of EUT	GNSS RECEIVER
Model No.	K3, K5, K9, R90i, R8i, C1, T3, T5, H3 plus, A20, M6
Model Declaration	PCB board, structure and internal of these model(s) are the same, so no additional models were tested
Test Model	K5
Power Supply	DC 7.4V by Rechargeable Li-ion Battery(3400mAh) or DC 13.8V by external power Recharged by DC 4.2V 1.35A or DC 8.4V/0.67A for battery
Hardware version	SG3000001
Software version	GalaxyRTK_LWB-V20181210
GSM/EDGE/GPRS Operation Frequency Band	GSM850/PCS1900/GPRS850/GPRS1900/EDGE850/EDGE1900
UMTS Operation Frequency Band	UMTS FDD Band I/V/VIII
LTE Operation Frequency Band	LTE Band 38/39/40/41
Modulation Type	GMSK for GSM/GPRS; 8-PSK for EDGE; QPSK for UMTS; QPSK, 16QAM for LTE
GSM/EDGE/GPRS	Supported GSM/GPRS/EDGE
GSM Release Version	R99
GSM/EDGE/GPRS Power Class	GSM850:Power Class 4/ PCS1900:Power Class 1
GPRS/EDGE Multislot Class	GPRS/EDGE: Multi-slot Class 12
GPRS operation mode	Class B
WCDMA Release Version	R8
HSDPA Release Version	Release 8
HSUPA Release Version	Release 8
DC-HSUPA Release Version	Not Supported
LTE Release Version	Release 9
LTE/UMTS Power Class	Class 3
Antenna Type	SMA Antenna
Antenna Gain	2.0dBi (max.) for GSM 850, PCS 1900; 2.0dBi (max.) for WCDMA Band V; 2.0dBi (max.) for LTE Band 41
BT FCC Operation frequency	2402-2480MHz
BT FCC Modulation Type	GFSK, $\pi/4$ -DQPSK, 8-DPSK for Bluetooth V4.0 (BDR/EDR) GFSK for Bluetooth V4.0 (BT LE)
Bluetooth Version	V4.0
Antenna Type	Ceramic Antenna
Antenna Gain	2.0dBi (max.) for Bluetooth
WLAN FCC Operation frequency	IEEE 802.11b/g/n HT20:2412-2462MHz
WLAN FCC Modulation Type	IEEE 802.11b: DSSS(CCK,DQPSK,DBPSK) IEEE 802.11g/n: OFDM(64QAM, 16QAM, QPSK, BPSK)
Antenna Type	Ceramic Antenna
Antenna Gain	2.0dBi (max.) for WLAN
PMR FCC Operation frequency	460.125-467.625MHz
Channel Separation	12.5KHz & 25KHz
Modulation Type	GMSK
Emission Designator	11K0G1D for GMSK Modulation at 12.5KHz Channel Separation 16K0G1D for GMSK Modulation at 25KHz Channel Separation
Rate Power	25W/10W
Antenna Type	SMA Antenna
Antenna Gain	5.0dBi (max.) for PMR
GPS function	Support and only RX
FM function	Support and only RX
NFC Function	Support and only RX
Extreme temp. Tolerance	-10°C to +55°C
Extreme Voltage Tolerance	DC 6.66V to 8.14V

1.2. Host System Configuration List and Details

Manufacturer	Description	Model	Serial Number	Certificate
Lenovo	PC	B470	--	DOC
Lenovo	AC/DC ADAPTER	ADP-90DDB	--	DOC
SHENZHEN RUIJING INDUSTRIAL CO.,LTD.	Adapter Power	RJT-AS120300 C301	---	DOC
SOUTH	Desktop Charger	CH-SA3012	---	DOC

1.3. External I/O Cable

I/O Port Description	Quantity	Cable
Antenna Port	1	N/A
SIM Card Slot	1	N/A
5-pin cable socket	1	N/A
7-pin data cable socket	1	N/A

1.4. Description of Test Facility

FCC Registration Number is 254912.

Industry Canada Registration Number is 9642A-1.

ESMD Registration Number is ARCB0108.

UL Registration Number is 100571-492.

TUV SUD Registration Number is SCN1081.

TUV RH Registration Number is UA 50296516-001.

NVLAP Registration Code is 600167-0.

FCC Designation Number is CN5024.

CAB identifier is CN0071.

The 3m-Semi anechoic test site fulfils CISPR 16-1-4 according to ANSI C63.4:2014 and CISPR 16-1-4:2010 SVSWR requirement for radiated emission above 1GHz.

1.5. Statement of the Measurement Uncertainty

The data and results referenced in this document are true and accurate. The reader is cautioned that there may be errors within the calibration limits of the equipment and facilities. The measurement uncertainty was calculated for all measurements listed in this test report acc. To CISPR 16 – 4 “Specification for radio disturbance and immunity measuring apparatus and methods – Part 4: Uncertainty in EMC Measurements” and is documented in the LCS quality system acc. To DIN EN ISO/IEC 17025. Furthermore, component and process variability of devices similar to that tested may result in additional deviation. The manufacturer has the sole responsibility of continued compliance of the device.

1.6. Measurement Uncertainty

Test Item	Uncertainty	Note
Frequency error	30 Hz	(1)
Transmitter power conducted	0.62 dB	(1)
Transmitter power Radiated	2.67 dB	(1)
Conducted spurious emission 9KHz-12.75 GHz	1.88 dB	(1)
Conducted Emission 9KHz-30MHz	1.63 dB	(1)
Radiated spurious emission 30~1000MHz	4.65 dB	(1)
Radiated spurious emission 1~18GHz	3.89 dB	(1)
Radiated spurious emission 18-40GHz	3.90 dB	(1)
Occupied Bandwidth	N/A	N/A
Emission Mask	N/A	N/A
Modulation Characteristic	N/A	N/A
Transmitter Frequency Behavior	N/A	N/A

(1). This uncertainty represents an expanded uncertainty expressed at approximately the 95% confidence level using a coverage factor of k=2.

1.7. Description of Test Modes

The EUT has been tested under typical operating condition. As, test modes selected as below by the technical parameters of the EUT:

Operation Mode	Description of operation mode	Additional information
TM1	GMSK+BW12.5KHz+TX	The EUT is set with GMSK modulation and 12.5KHz bandwidth at maximum rated power for transmitter, powered by DC 7.40V power Rechargeable Li-ion Battery
TM2	GMSK+BW12.5KHz+TX	The EUT is set with GMSK modulation and 12.5KHz bandwidth at minimum rated power for transmitter, powered by DC 7.40V power Rechargeable Li-ion Battery
TM3	GMSK+BW25KHz+TX	The EUT is set with GMSK modulation and 25KHz bandwidth at maximum rated power for transmitter, powered by DC 7.40V power Rechargeable Li-ion Battery
TM4	GMSK+BW25KHz+TX	The EUT is set with GMSK modulation and 25KHz bandwidth at minimum rated power for transmitter, powered by DC 7.40V power Rechargeable Li-ion Battery

Frequency list:

Modulation Type	Channel Separation	Channel	Frequency (MHz)	Channel	Frequency (MHz)
GMSK	12.5KHz	1	460.125	9	464.125
		2	460.625	10	464.625
		3	461.125	11	465.125
		4	461.625	12	465.625
		5	462.125	13	466.125
		6	462.625	14	466.625
		7	463.125	15	467.125
		8	463.625	16	467.625
GMSK	25KHz	1	460.125	9	464.125
		2	460.625	10	464.625
		3	461.125	11	465.125
		4	461.625	12	465.625
		5	462.125	13	466.125
		6	462.625	14	466.625
		7	463.125	15	467.125
		8	463.625	16	467.625

Note: The line display in grey was the channel selected for test.

2. SYSTEM TEST CONFIGURATION

2.1. TEST STANDARDS

The tests were performed according to following standards:

[FCC Rules Part 90](#): PRIVATE LAND MOBILE RADIO SERVICES.

[ANSI/TIA-603-E-2016](#): Land Mobile FM or PM Communications Equipment Measurement and Performance Standards.

[47 CFR FCC Part 15 Subpart B](#): Unintentional Radiators

[FCC Part 2](#): FREQUENCY ALLOCATIONS AND RADIO TREATY MATTERS; GENERAL RULES AND REGULATIONS

[ANSI C63.26:2015](#): American National Standard for Compliance Testing of Transmitters Used in Licensed Radio Services.

[ANSI C63.10: 2013](#): American National Standard for Testing Unlicensed Wireless Devices

2.2. EUT Configuration

The EUT configuration for testing is installed on RF field strength measurement to meet the Commissions requirement and operating in a manner that intends to maximize its emission characteristics in a continuous normal application.

2.3. EUT Exercise

The EUT has been tested under typical operating condition and The Transmitter was operated in the normal operating mode. The TX frequency was fixed which was for the purpose of the measurements.

2.4. General Test Procedures

2.4.1 Conducted Emissions

N/A

2.4.2 Radiated Emissions

The EUT is placed on a turntable, which is directly placed on the ground. The turntable shall rotate 360 degrees to determine the position of maximum emission level. EUT is set 3m away from the receiving antenna, which varied from 1m to 4m to find out the highest emission. And also, each emission was to be maximized by changing the polarization of receiving antenna both horizontal and vertical. In order to find out the maximum emissions, exploratory radiated emission measurements were made according to the requirements in Section 6.3 of ANSI C63.10-2013

2.5. Test Sample

The application provides 1 samples to meet requirement;

Sample Number	Description
Sample 1	continuous transmit

3. SYSTEM TEST CONFIGURATION

3.1. Justification

The system was configured for testing in a continuous transmits condition.

3.2. EUT Exercise Software

N/ A

3.3. Special Accessories

N/ A

3.4. Block Diagram/Schematics

Please refer to the related document

3.5. Equipment Modifications

Shenzhen LCS Compliance Testing Laboratory Ltd. has not done any modification on the EUT.

3.6. Test Setup

Please refer to the test setup photo.

4. SUMMARY OF TEST RESULT

Applied Standard: FCC Part 90				
FCC Rules	Description of Test	Test Sample	Result	Remark
FCC Part 90.205	Maximum Transmitter Power	Sample 1	Compliant	Note 1
FCC Part 90.207 FCC Part 2.1047 (a)	Modulation Characteristics - Audio Frequency Response	Sample 1	N/A*	Note 2
FCC Part 90.207 FCC Part 2.1047 (b)	Modulation Characteristics - Modulation Limiting	Sample 1	Compliant	Note 1
FCC Part 90.209	Occupied Bandwidth	Sample 1	Compliant	Note 1
FCC Part 90.210	Emission Mask	Sample 1	Compliant	Note 1
FCC Part 90.213	Frequency Stability	Sample 1	Compliant	Note 1
FCC Part 90.214	Transmitter Frequency Behavior	Sample 1	Compliant	Note 1
FCC Part 90.210	Transmitter Radiated Spurious Emission	Sample 1	Compliant	Note 1
FCC Part 90.210	Spurious Emission On Antenna Port	Sample 1	Compliant	Note 1

Remark:

1. Note 1 – Test results inside test report;
2. Note 2 – N/A* - Not Applicable for this device.

5. TEST CONDITIONS AND RESULTS

5.1. Maximum Transmitter Power

5.1.1 Test Applicable

Per FCC Part 2.1046 and Part 90.205: Maximum ERP is dependent upon the station's antenna HAAT and required service area.

5.1.2 Test Procedure

Measurements shall be made to establish the radio frequency power delivered by the transmitter the standard output termination. The power output shall be monitored and recorded and no adjustment shall be made to the transmitter after the test has begun, except as noted below:

If the power output is adjustable, measurements shall be made for the highest and lowest power levels.

The EUT connect to the Receiver through 20 dB attenuator.

Measurement with Spectrum Analyzer conducted external power supply with 7.4 V stabilized supply voltage.

5.1.3 Test Configuration

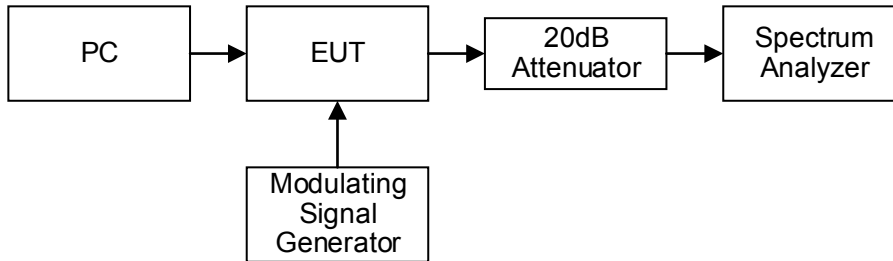

5.1.4 Test Results

Temperature	23.8°C	Humidity	52.9%
Test Engineer	Mina Xu	Test Voltage	Normal Voltage

Modulation Type	Channel Separation	Operation Mode	Test Channel	Test Frequency (MHz)	Test Results (dBm)	Test Results (W)	Limit (W)
Digital GMSK	12.5KHz	TM1	Ch1	460.125	38.223	6.642	500
			Ch8	463.625	38.233	6.657	500
			Ch16	467.625	38.233	6.657	500
		TM2	Ch1	460.125	34.260	2.667	500
			Ch8	463.625	34.257	2.665	500
			Ch16	467.625	34.395	2.751	500
Digital GMSK	25KHz	TM3	Ch1	460.125	38.224	6.644	500
			Ch8	463.625	38.229	6.651	500
			Ch16	467.625	38.231	6.654	500
		TM4	Ch1	460.125	34.437	2.778	500
			Ch8	463.625	34.439	2.779	500
			Ch16	467.625	34.436	2.777	500
Limit	The limit is dependent upon the station's antenna HAAT and required service area.						
Test Results	PASS						

Remark:

1. The station's antenna high (HAAT) is 15m and the service area radius is 15Km;
2. Please refer to following plot;

Transmitter Power

TM1

TM2

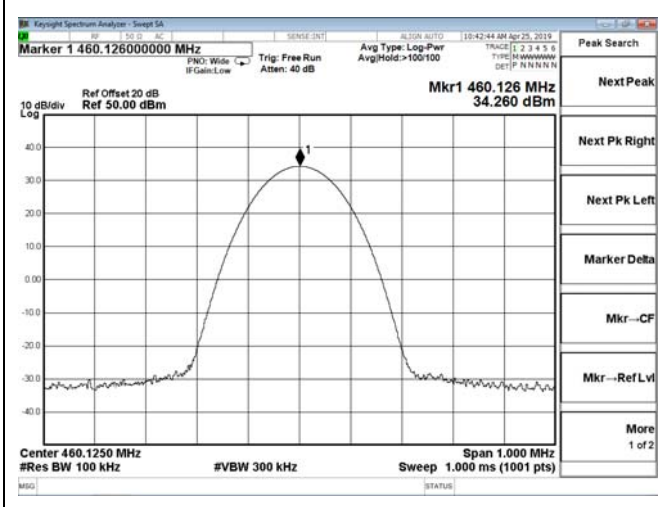
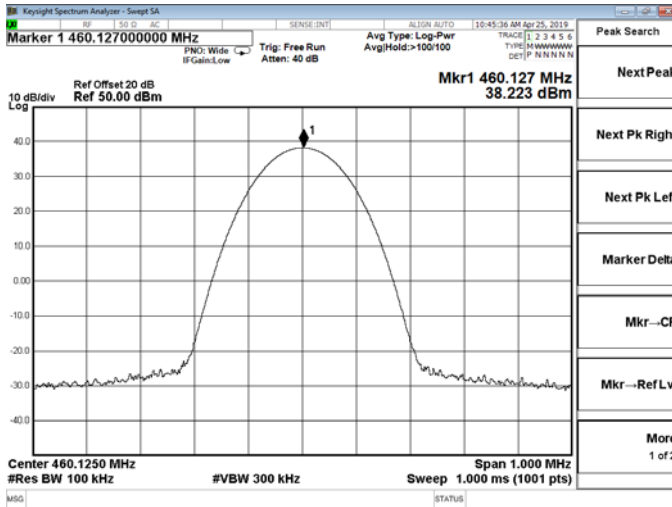

Channel 1 / 460.125 MHz

Channel 1 / 460.125 MHz

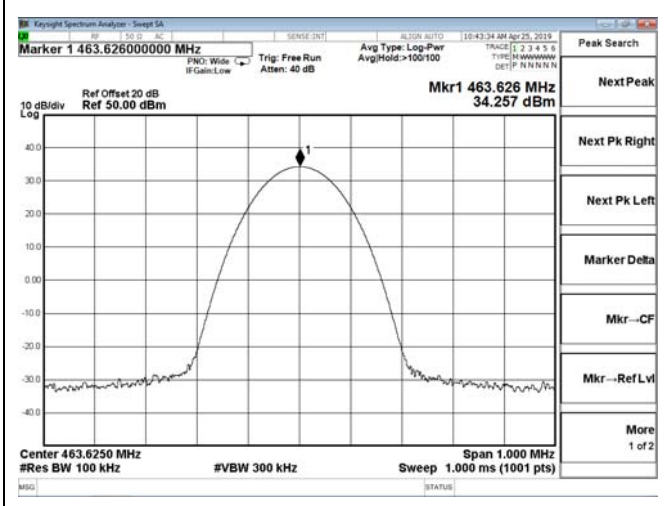
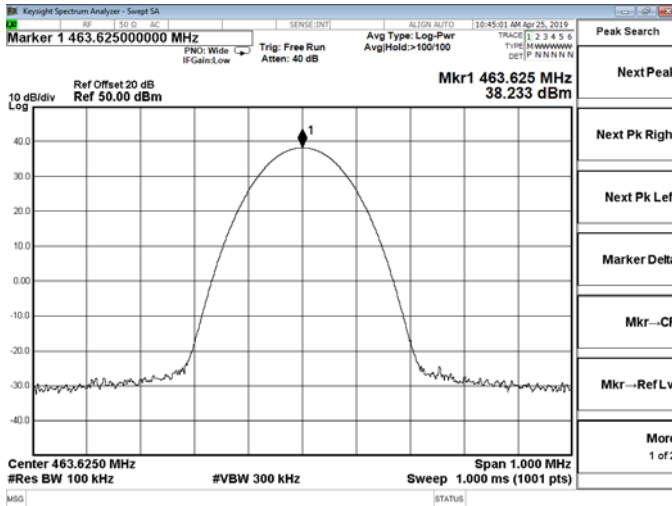

Channel 8 / 463.625 MHz

Channel 8 / 463.625 MHz

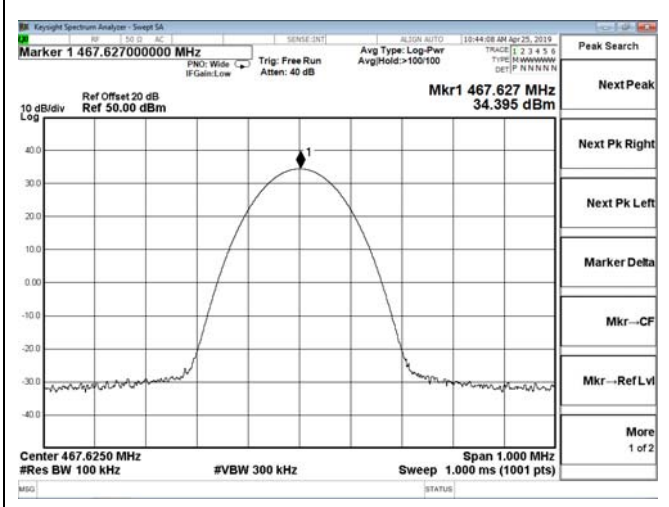
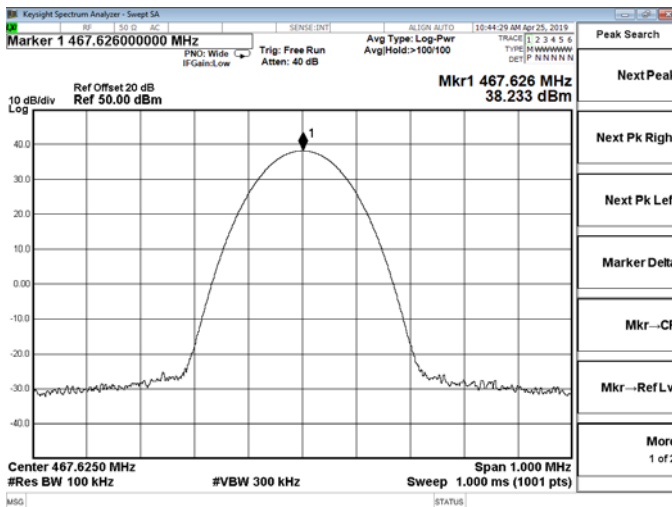

Channel 16 / 467.625 MHz

Channel 16 / 467.625 MHz

Transmitter Power

TM3

TM4

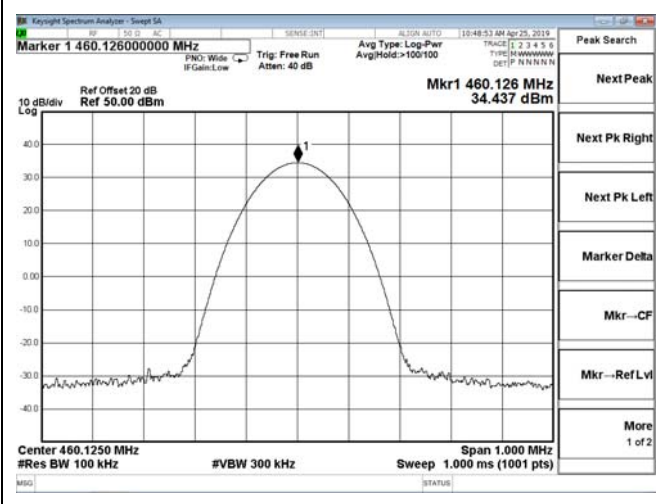
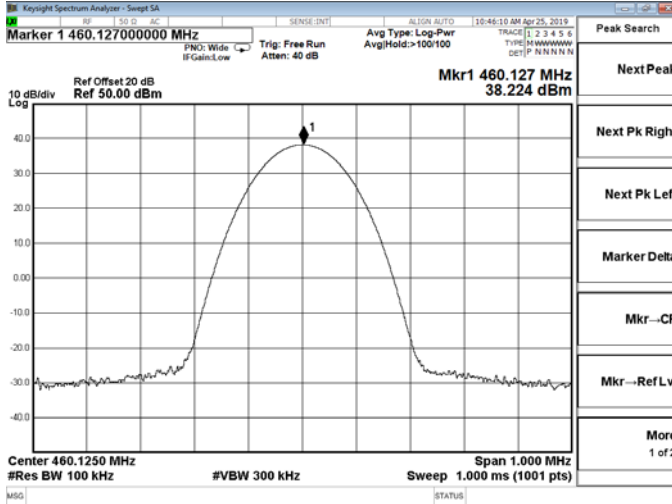

Channel 1 / 460.125 MHz

Channel 1 / 460.125 MHz

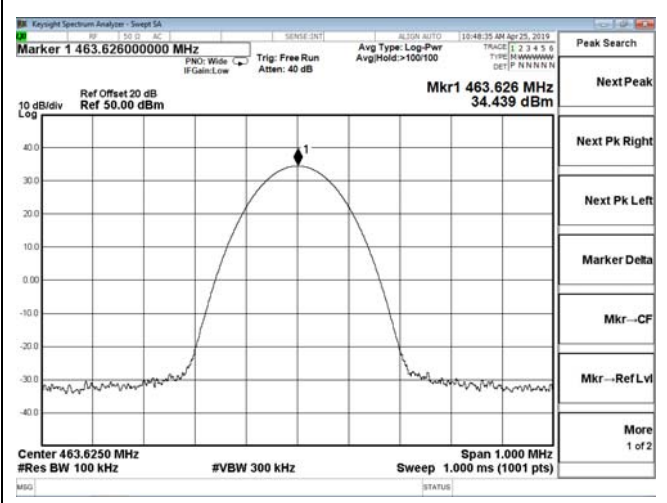
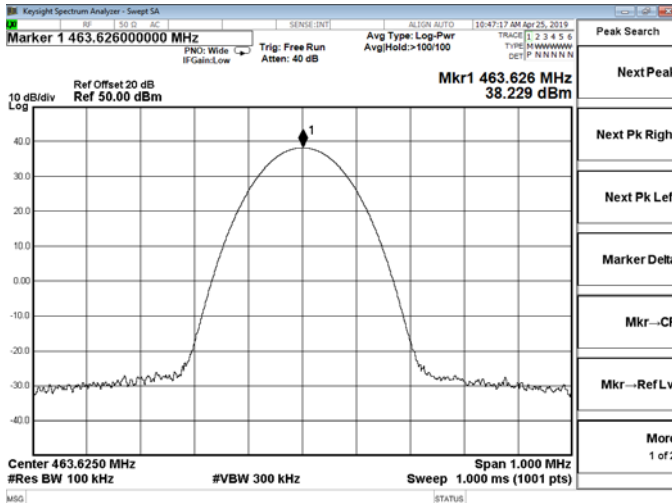

Channel 8 / 463.625 MHz

Channel 8 / 463.625 MHz

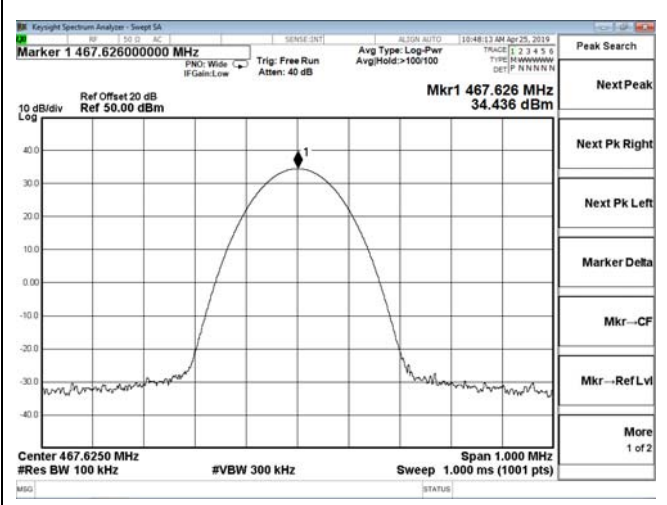
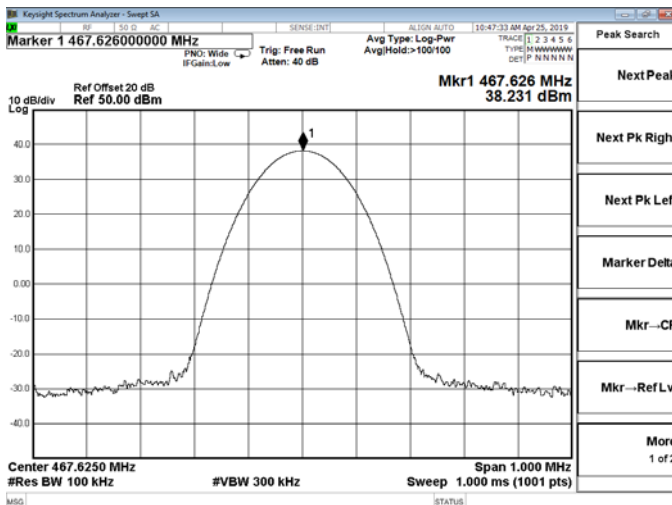

Channel 16 / 467.625 MHz

Channel 16 / 467.625 MHz

5.2. Occupied Bandwidth and Emission Mask Test

5.2.1 Test Applicable

- (a). Occupied Bandwidth: The EUT was connected to the audio signal generator and the spectrum analyser via the main RF connector, and through an appropriate attenuator. The EUT was controlled to transmit its maximum power. Then the bandwidth of 99% power can be measured by the spectrum analyser.
- (b). Emission Mask B: For transmitters that are equipped with an audio low-pass filter pursuant to §90.211(a), the power of any emission must be below the unmodulated carrier power (P) as follows:
- (1) On any frequency removed from the assigned frequency by more than 50 percent, but not more than 100 percent of the authorized bandwidth: At least 25dB.
 - (2) On any frequency removed from the assigned frequency by more than 100 percent, but not more than 250 percent of the authorized bandwidth: At least 35dB.
 - (3) On any frequency removed from the assigned frequency by more than 250 percent of the authorized bandwidth: At least $43 + 10 \log (P)$ dB.
- (c). Emission Mask D, 12.5 kHz channel bandwidth equipment: For transmitters designed to operate with a 12.5 kHz channel bandwidth, any emission must be attenuated below the power (P) of the highest emission contained within the authorized bandwidth as follows:
- (1) On any frequency from the centre of the authorized bandwidth f_0 to 5.625 kHz removed from f_0 : Zero dB.
 - (2) On any frequency removed from the centre of the authorized bandwidth by a displacement frequency (f_d in kHz) of more than 5.625 kHz but no more than 12.5 kHz: At least $7.27(f_d - 2.88 \text{ kHz})$ dB.
 - (3) On any frequency removed from the centre of the authorized bandwidth by a displacement frequency (f_d in kHz) of more than 12.5 kHz: At least $50 + 10 \log (P)$ dB or 70 dB, whichever is the lesser attenuation.

5.2.2 Test Configuration

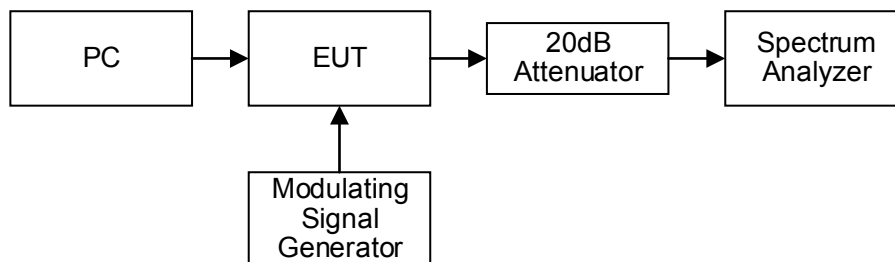

5.2.3 Test Procedure

- 1 Set EUT as normal operation.
- 2 Set SPA Centre Frequency = fundamental frequency, RBW=300Hz, VBW= 1 KHz, span =50 KHz for channel bandwidth 12.5 KHz and 100 KHz for channel bandwidth 25 KHz.
- 3 Set SPA Max hold. Mark peak, Set 99% Occupied Bandwidth and 26dB Occupied Bandwidth.

5.2.4 Test Results

Temperature	23.8°C	Humidity	52.9%
Test Engineer	Mina Xu	Test Voltage	Normal Voltage

Occupied Bandwidth

Modulation Type	Channel Separation	Operation Mode	Test Channel	Test Frequency (MHz)	Occupied Bandwidth (KHz)	
					99%	26dB
GMSK	12.5 KHz	TM1	Ch1	460.125	8.133	9.439
			Ch8	463.625	8.207	9.495
			Ch16	467.625	8.107	9.570
	25 KHz	TM3	Ch1	460.125	16.542	18.67
			Ch8	463.625	16.459	18.52
			Ch16	467.625	16.366	18.57
Limit			11.25KHz for 12.5KHz Channel Separation			
			20KHz for 25KHz Channel Separation			
Test Results			PASS			

Remark:

1. Measured at TM1 to TM4, recorded worst case at TM1 and TM3;
2. Please refer to following plots.

99% and 26dB Bandwidth

TM1

TM3

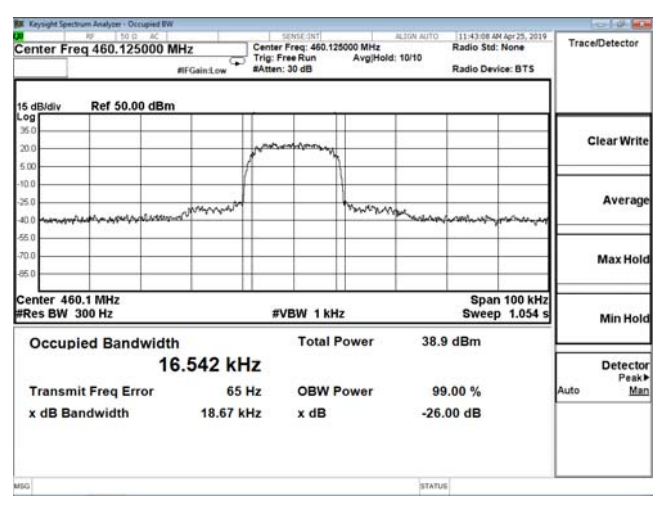
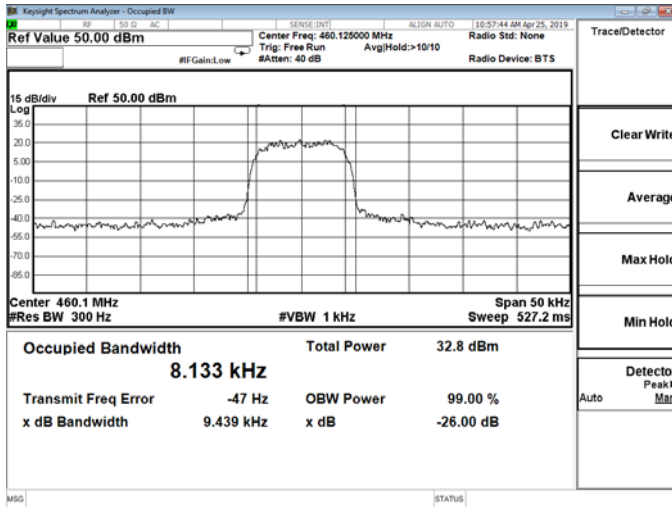

Channel 1 / 460.125 MHz

Channel 1 / 460.125 MHz

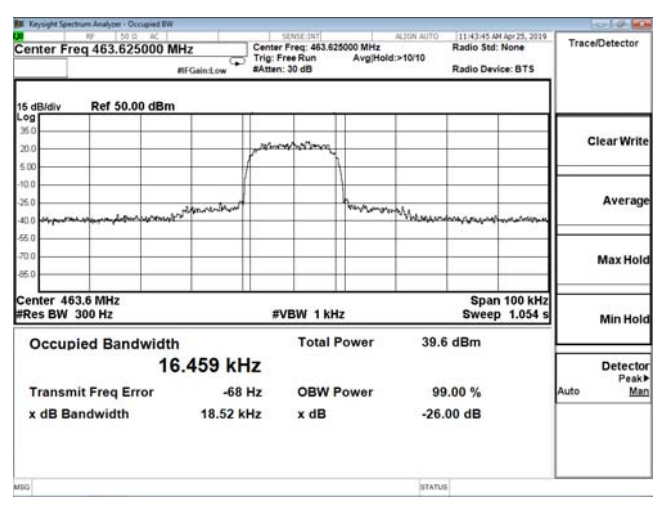
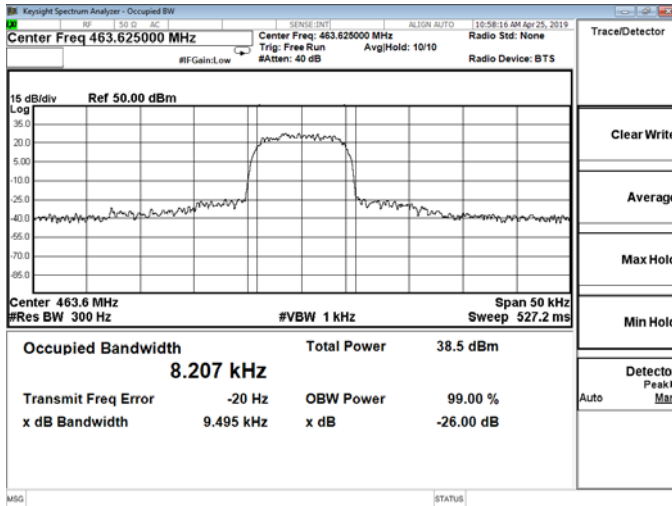

Channel 8 / 463.625 MHz

Channel 8 / 463.625 MHz

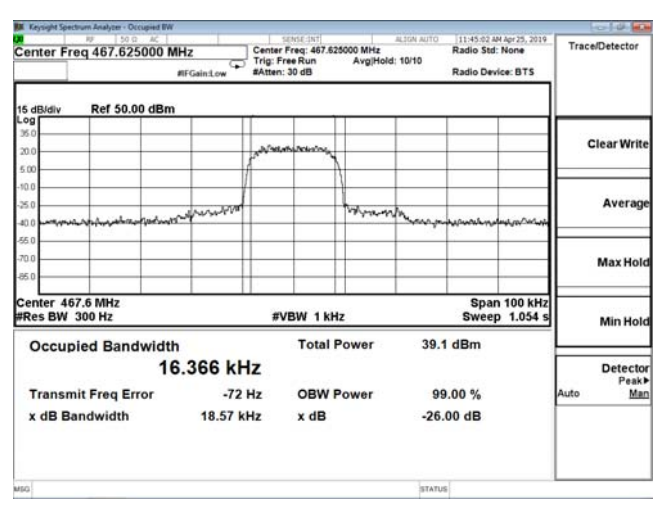
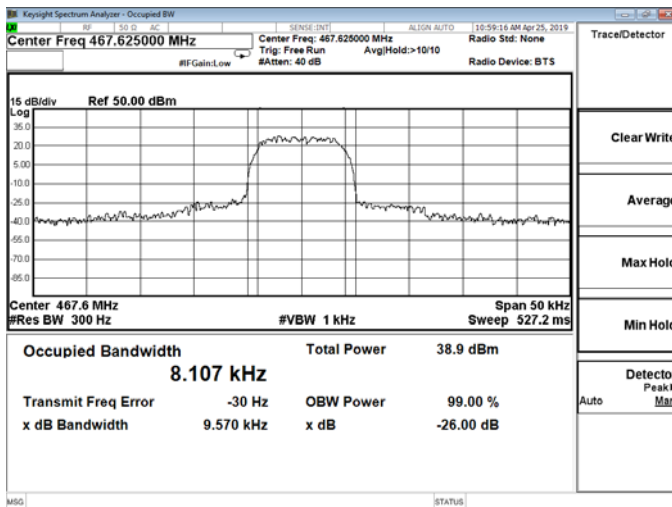

Channel 16 / 467.625 MHz

Channel 16 / 467.625 MHz

Temperature	23.8°C	Humidity	52.9%
Test Engineer	Mina Xu	Test Voltage	Normal Voltage

Emission Mask

Modulation Type	Channel Separation	Operation Mode	Test Channel	Test Frequency (MHz)	Applicable Mask	RBW (Hz)
GMSK	12.5 KHz	TM1	Ch1	460.125	D	300
			Ch8	463.625	D	300
			Ch16	467.625	D	300
	25 KHz	TM3	Ch1	460.125	B	300
			Ch8	463.625	B	300
			Ch16	467.625	B	300
Test Results			PASS			

Remark:

1. Measured at TM1 to TM4, recorded worst case at TM1 and TM3;
2. Please refer to following plots.

Emission Mask

TM1

TM3

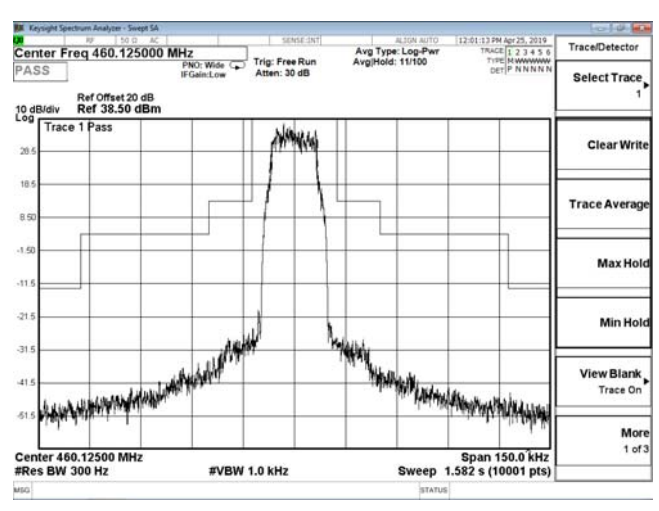
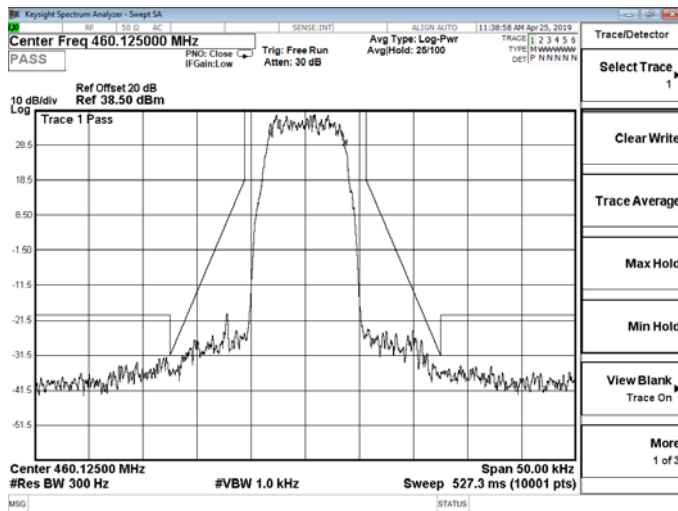

Channel 1 / 460.125 MHz

Channel 1 / 460.125 MHz

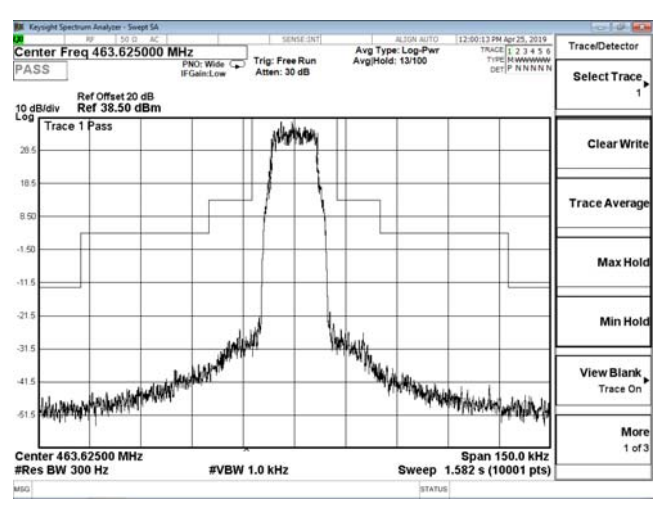
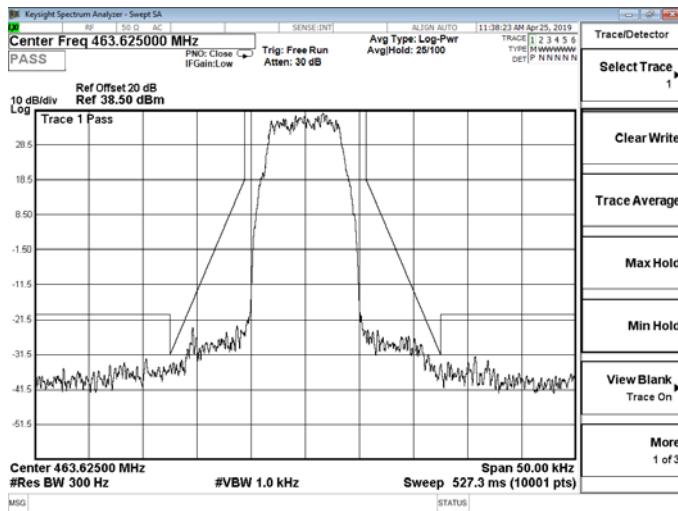

Channel 8 / 463.625 MHz

Channel 8 / 463.625 MHz

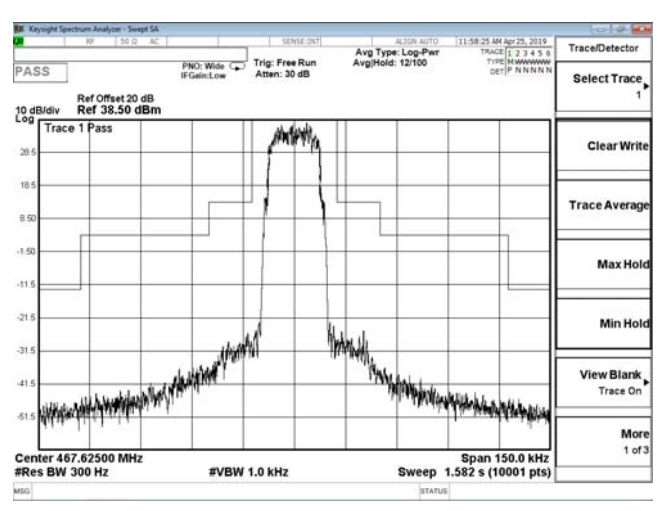
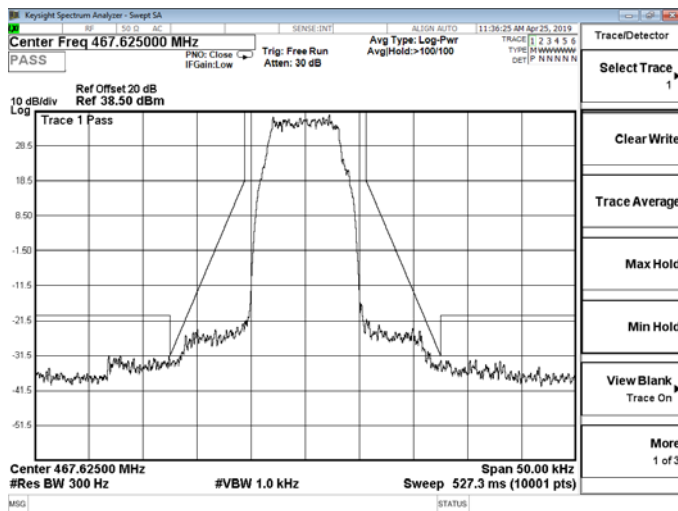

Channel 16 / 467.625 MHz

Channel 16 / 467.625 MHz

5.3. Transmitter Radiated Spurious Emission

5.3.1 Test Applicable

According to the ANSI C63.26:2015 test method, and according to Section 90.210, the power of each unwanted emission shall be less than Transmitted Power as specified below for transmitters designed to operate with 12.5 KHz channel bandwidth:

- 1 On any frequency removed from the centre of the authorized bandwidth f_0 to 5.625 KHz removed from f_0 : Zero dB
- 2 On any frequency removed from the centre of the authorized bandwidth by a displacement frequency (f_d in KHz) f_0 of more than 5.625 KHz but no more than 12.5 KHz: At least 7.27dB
- 3 On any frequency removed from the centre of the authorized bandwidth by a displacement frequency (f_d in KHz) f_0 of more than 12.5 KHz: At least $50+10 \log (P)$ dB or 70 dB, whichever is lesser attenuation.

For transmitters designed to transmit with 25 KHz channel separation and equipped with an audio low-pass filter, the power of any emission must be attenuated below the unmodulated carrier power (P) as following:

- 1 On any frequency removed from the assigned frequency by more than 50 percent, but no more than 100 percent of the authorized bandwidth: At least 25 dB.
- 2 On any frequency removed from the assigned frequency by more than 100 percent, but no more than 250 percent of the authorized bandwidth: At least 35 dB.
- 3 On any frequency removed from the assigned frequency by more than 250 percent of the authorized bandwidth: At least $43+10\log (P)$ dB.

5.3.2 Test Configuration

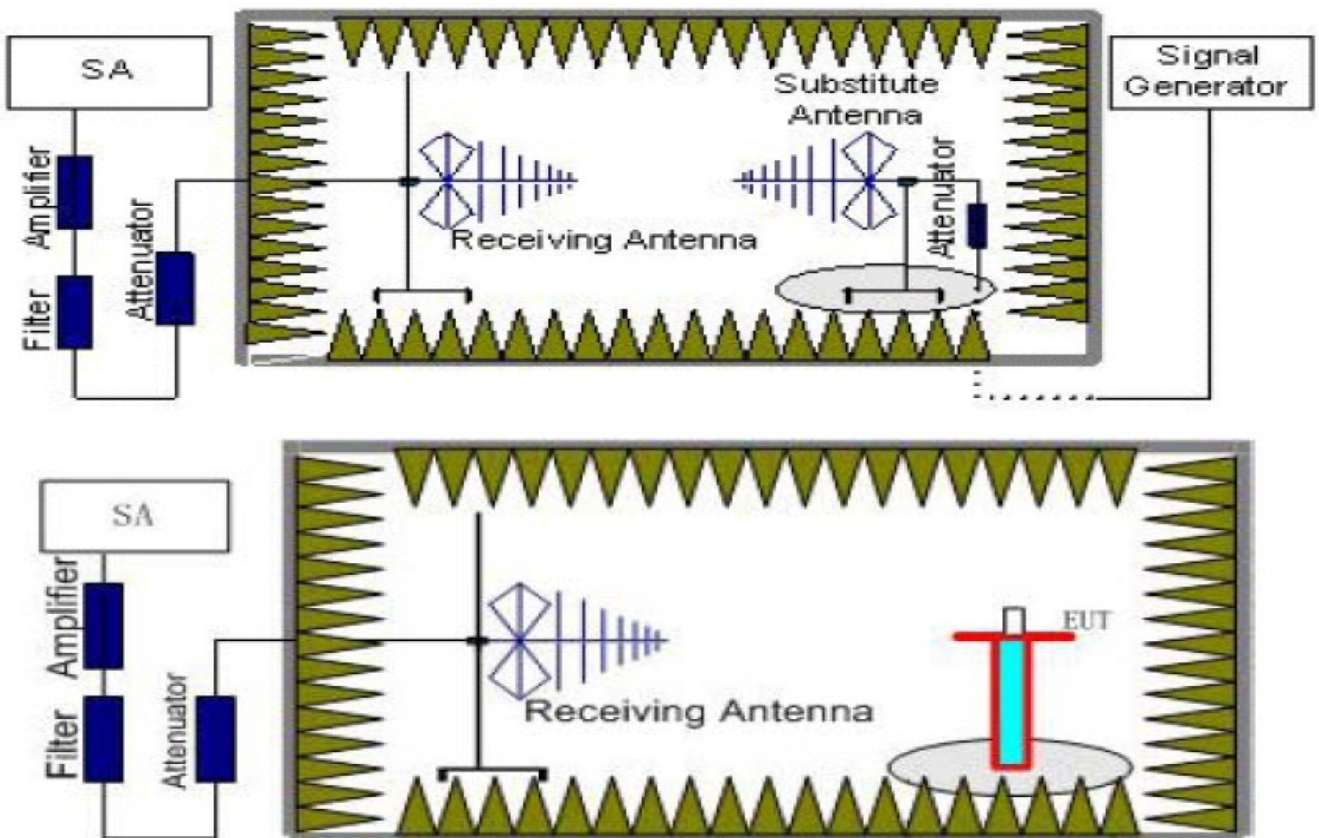

5.3.3 Test Arrangement

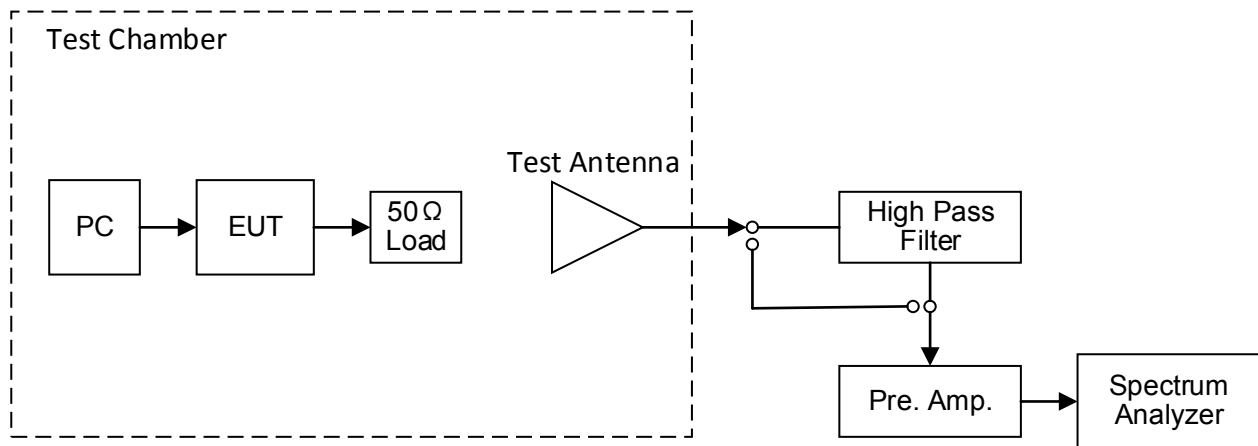

5.3.4 Test Procedure

1. EUT was placed on a 1.50 meter high non-conductive stand at a 3 meter test distance from the receive antenna. A receiving antenna was placed on the antenna mast 3 meters from the EUT for emission measurements. The height of receiving antenna is 1.50 m. Detected emissions were maximized at each frequency by rotating the EUT through 360° and adjusting the receiving antenna polarization. The radiated emission measurements of all transmit frequencies in six channels were measured with peak detector.
2. A log-periodic antenna or double-ridged waveguide horn antenna shall be substituted in place of the EUT. The log-periodic antenna will be driven by a signal generator and the level will be adjusted till the same power value on the spectrum analyzer or receiver. The level of the spurious emissions can be calculated through the level of the signal generator, cable loss, the gain of the substitution antenna and the reading of the spectrum analyzer or receiver.
3. The EUT is then put into continuously transmitting mode at its maximum power level during the test. Set Test Receiver or Spectrum RBW=1MHz, VBW=3MHz for above 1GHz and RBW=100 KHz, VBW=300 KHz for 30MHz to 1GHz, and the maximum value of the receiver should be recorded as (P_r).
4. The EUT shall be replaced by a substitution antenna. In the chamber, a substitution antenna for the frequency band of interest is placed at the reference point of the chamber. An RF Signal source for the frequency band of interest is connected to the substitution antenna with a cable that has been constructed to not interfere with the radiation pattern of the antenna. A power (P_{Mea}) is applied to the input of the substitution antenna, and adjusts the level of the signal generator output until the value of the receiver reach the previously recorded (P_r). The power of signal source (P_{Mea}) is recorded. The test should be performed by rotating the test item and adjusting the receiving antenna polarization.
5. An amplifier should be connected to the Signal Source output port. And the cable should be connecting between the Amplifier and the Substitution Antenna. The cable loss (P_{cl}), the Substitution Antenna Gain (G_a) and the Amplifier Gain (P_{Ag}) should be recorded after test.

The measurement results are obtained as described below:

$$\text{Power (EIRP)} = P_{Mea} - P_{Ag} - P_{cl} - G_a$$

The measurement results are amending as described below:

$$\text{Power (EIRP)} = P_{Mea} - P_{cl} - G_a$$

6. This value is EIRP since the measurement is calibrated using an antenna of known gain (2.15 dBi) and known input power.
7. ERP can be calculated from EIRP by subtracting the gain of the dipole, $ERP = EIRP - 2.15 \text{ dBi}$.

5.3.5 Limit

Modulation Type: GMSK

FCC Part 22.359, 74.462, 80.211 and 90.211 and RSS Gen, RSS 119 Issue 12:

For 12.5 kHz bandwidth:

On any frequency removed from the center of the authorized bandwidth by a displacement frequency (f_d in kHz) of more than 12.5 kHz at least:

High: $50 + 10 \log (P_{\text{watts}}) = 50 + 10 \log (25) = 63.97 \text{ dB}$

Low: $50 + 10 \log (P_{\text{watts}}) = 50 + 10 \log (10) = 60.00 \text{ dB}$

Note: In general, the worst case attenuation requirement shown above was applied.

Calculation: Limit (dBm) = EL - 50 - 10log (TP)

Notes: EL is the emission level of the Output Power expressed in dBm,

In this application, the EL is 43.98 dBm for High rated power and 40.00 for lower rated power.

High: Limit (dBm) = $43.98 - 50 - 10 \log (25) = -20 \text{ dBm}$

Low: Limit (dBm) = $40.00 - 50 - 10 \log (10) = -20 \text{ dBm}$

For 25 kHz bandwidth:

On any frequency removed from the center of the authorized bandwidth by a displacement frequency (f_d in kHz) of more than 62.5 kHz at least:

High: $43 + 10 \log (P_{\text{watts}}) = 43 + 10 \log (25) = 56.97 \text{ dB}$

Low: $43 + 10 \log (P_{\text{watts}}) = 43 + 10 \log (10) = 53.00 \text{ dB}$

Note: In general, the worst case attenuation requirement shown above was applied.

Calculation: Limit (dBm) = EL - 43 - 10log10 (TP)

In this application, the EL is 43.98 dBm for High rated power and 40.00 for lower rated power.

High: Limit (dBm) = $43.98 - 43 - 10 \log (25) = -13 \text{ dBm}$

Low: Limit (dBm) = $40.00 - 43 - 10 \log (10) = -13 \text{ dBm}$

Note: 1. In general, the worst case attenuation requirement shown above was applied.

2. The measurement frequency range from 9 KHz to 5 GHz.

3. *** means that the emission level is too low to be measured or at least 20 dB down than the limit.

4. ERP for below 1GHz and EIRP above 1GHz.

5.3.5 Test Results

Temperature	23.8°C	Humidity	52.9%
Test Engineer	Mina Xu	Test Voltage	Normal Voltage

Remark:

1. Measured at TM1 to TM4, recorded worst case at TM1 and TM3;

2. Please refer to following page.

Modulation Type: GMSK							
Operation Mode: TM1				Channel Separation:12.5KHz			
Test Channel: Channel 1				Test Frequency:460.125MHz			
Frequency (MHz)	P _{Mea} (dBm)	Path Loss	Antenna Gain	Correction (dB)	Peak EIRP (dBm)	Limit (dBm)	Polarization
920.250	-47.53	0.87	6.42	2.15	-38.09	-20.00	H
1380.375	-51.45	1.02	7.35	2.15	-40.93	-20.00	H
2300.625	-44.42	1.10	8.26	2.15	-32.91	-20.00	H
920.250	-59.40	0.87	6.42	2.15	-49.96	-20.00	V
1380.375	-47.08	1.02	7.35	2.15	-36.56	-20.00	V
2300.625	-57.99	1.10	8.26	2.15	-46.48	-20.00	V

Modulation Type: GMSK							
Operation Mode: TM1				Channel Separation:12.5KHz			
Test Channel: Channel 8				Test Frequency: 463.625MHz			
Frequency (MHz)	P _{Mea} (dBm)	Path Loss	Antenna Gain	Correction (dB)	Peak EIRP (dBm)	Limit (dBm)	Polarization
927.250	-43.03	0.92	6.8	2.15	-33.16	-20.00	H
1390.375	-59.58	1.06	7.89	2.15	-48.48	-20.00	H
2318.125	-44.89	1.12	8.12	2.15	-33.50	-20.00	H
927.250	-50.04	0.92	6.8	2.15	-40.17	-20.00	V
1390.375	-45.88	1.06	7.89	2.15	-34.78	-20.00	V
2318.125	-50.71	1.12	8.12	2.15	-39.32	-20.00	V

Modulation Type: GMSK							
Operation Mode: TM1				Channel Separation:12.5KHz			
Test Channel: Channel 16				Test Frequency: 467.625MHz			
Frequency (MHz)	P _{Mea} (dBm)	Path Loss	Antenna Gain	Correction (dB)	Peak EIRP (dBm)	Limit (dBm)	Polarization
935.250	-40.80	0.95	6.80	2.15	-30.90	-20.00	H
1402.875	-58.94	1.10	7.91	2.15	-47.78	-20.00	H
2338.125	-47.61	1.21	8.25	2.15	-36.00	-20.00	H
935.250	-58.42	0.95	6.80	2.15	-48.52	-20.00	V
1402.875	-46.18	1.10	7.91	2.15	-35.02	-20.00	V
2338.125	-53.01	1.21	8.25	2.15	-41.40	-20.00	V

Modulation Type: GMSK							
Operation Mode: TM3				Channel Separation:25KHz			
Test Channel: Channel 1				Test Frequency:460.125MHz			
Frequency (MHz)	P _{Mea} (dBm)	Path Loss	Antenna Gain	Correction (dB)	Peak EIRP (dBm)	Limit (dBm)	Polarization
920.250	-46.71	0.87	6.42	2.15	-37.27	-13.00	H
1380.375	-57.76	1.02	7.35	2.15	-47.24	-13.00	H
2300.625	-45.88	1.10	8.26	2.15	-34.37	-13.00	H
920.250	-54.36	0.87	6.42	2.15	-44.92	-13.00	V
1380.375	-50.84	1.02	7.35	2.15	-40.32	-13.00	V
2300.625	-60.76	1.10	8.26	2.15	-49.25	-13.00	V

Modulation Type: GMSK							
Operation Mode: TM3				Channel Separation:25KHz			
Test Channel: Channel 8				Test Frequency: 463.625MHz			
Frequency (MHz)	P _{Mea} (dBm)	Path Loss	Antenna Gain	Correction (dB)	Peak EIRP (dBm)	Limit (dBm)	Polarization
927.250	-40.33	0.92	6.8	2.15	-30.46	-13.00	H
1390.375	-58.23	1.06	7.89	2.15	-47.13	-13.00	H
2318.125	-45.51	1.12	8.12	2.15	-34.12	-13.00	H
927.250	-56.47	0.92	6.8	2.15	-46.60	-13.00	V
1390.375	-41.47	1.06	7.89	2.15	-30.37	-13.00	V
2318.125	-58.96	1.12	8.12	2.15	-47.57	-13.00	V

Modulation Type: GMSK							
Operation Mode: TM3				Channel Separation:25KHz			
Test Channel: Channel 16				Test Frequency: 467.625MHz			
Frequency (MHz)	P _{Mea} (dBm)	Path Loss	Antenna Gain	Correction (dB)	Peak EIRP (dBm)	Limit (dBm)	Polarization
935.250	-42.91	0.95	6.80	2.15	-33.01	-13.00	H
1402.875	-58.19	1.10	7.91	2.15	-47.03	-13.00	H
2338.125	-43.92	1.21	8.25	2.15	-32.31	-13.00	H
935.250	-55.84	0.95	6.80	2.15	-45.94	-13.00	V
1402.875	-40.12	1.10	7.91	2.15	-28.96	-13.00	V
2338.125	-52.72	1.21	8.25	2.15	-41.11	-13.00	V

Notes:

- 1). Measuring frequencies from 9 KHz~10th harmonic (ex. 26GHz), No emission found between lowest internal used/generated frequency to 30MHz;
- 2). Radiated emissions measured in frequency range from 9 KHz~10th harmonic (ex. 26GHz) were made with an instrument using Peak detector mode;
- 3). Peak EIRP = P_{Mea} + Path Loss + Antenna Gain + Correction Value (2.15).

5.4. Spurious Emission on Antenna Port

5.4.1 Test Applicable

The same as Section 5.3

5.4.2 Test Procedure

The RF output of the EUT was connected to a spectrum analyzer through appropriate attenuation. The resolution bandwidth of the spectrum analyzer was set to 100 kHz. Sufficient scans were taken to show any out of band emission up to 10th. Harmonic for the lower and the highest frequency range. Set RBW 1KHz, VBW 3KHz in the frequency band 9KHz to 150KHz, set RBW 10KHz, VBW 30 KHz in the frequency band 150KHz to 30 MHz, set RBW 100 kHz, VBW 300 kHz in the frequency band 30MHz to 1GHz, while set RBW=1MHz.VBW=3MHz from the 1GHz to 10th Harmonic.

The audio input was set to 0 to get the unmodulated carrier, the resulting picture is print out for each channel separation.

5.4.3 Test Configuration

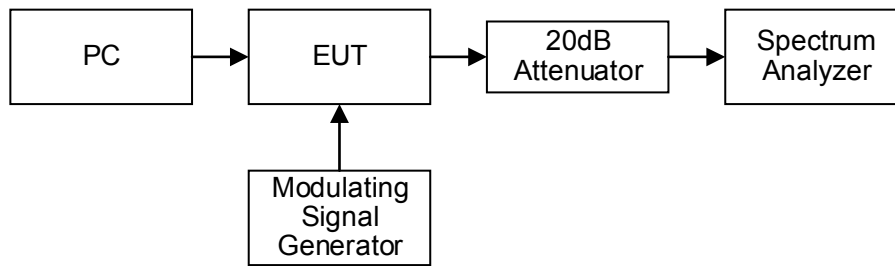

5.4.4 Limit

Modulation Type: GMSK

FCC Part 22.359, 74.462, 80.211 and 90.210 and RSS Gen, RSS 119 Issue 12:

For 12.5 kHz bandwidth:

On any frequency removed from the center of the authorized bandwidth by a displacement frequency (f_d in kHz) of more than 12.5 kHz at least:

High: $50 + 10 \log (P_{\text{watts}}) = 50 + 10 \log (25) = 63.98 \text{ dB}$

Low: $50 + 10 \log (P_{\text{watts}}) = 50 + 10 \log (12) = 60.79 \text{ dB}$

Note: In general, the worst case attenuation requirement shown above was applied.

Calculation: Limit (dBm) = EL - 50 - 10log (TP)

Notes: EL is the emission level of the Output Power expressed in dBm,

In this application, the EL is 43.98 dBm for High rated power and 40.79 dBm for lower rated power.

High: Limit (dBm) = $43.98 - 50 - 10 \log (25) = -20 \text{ dBm}$

Low: Limit (dBm) = $40.79 - 50 - 10 \log (12) = -20 \text{ dBm}$

For 25 kHz bandwidth:

On any frequency removed from the center of the authorized bandwidth by a displacement frequency (f_d in kHz) of more than 62.5 kHz at least:

High: $43 + 10 \log (P_{\text{watts}}) = 43 + 10 \log (25) = 56.98 \text{ dB}$

Low: $43 + 10 \log (P_{\text{watts}}) = 43 + 10 \log (12) = 53.79 \text{ dB}$

Note: In general, the worst case attenuation requirement shown above was applied.

Calculation: Limit (dBm) = EL-43-10log (TP)

In this application, the EL is 43.98 dBm for High rated power and 40.79 dBm for lower rated power.

High: Limit (dBm) = 43.98 – 43 – 10log (25) = -13 dBm

Low: Limit (dBm) = 40.79 – 43 – 10log (12) = -13 dBm

Note: 1. In general, the worst case attenuation requirement shown above was applied.

2. The measurement frequency range from 9 KHz to 6GHz.

5.4.5 Test Results

Temperature	23.8°C	Humidity	52.9%
Test Engineer	Mina Xu	Test Voltage	Normal Voltage

Operation Mode	Test Channel	Test Frequency (MHz)	Measured Frequency Range	Spurious RF Conducted Emission (dBc)	Limits (dBc)	Verdict
TM1	Ch1	460.125	9 KHz – 6 GHz	<-20	-20	PASS
	Ch8	463.625	9 KHz – 6 GHz	<-20		
	Ch16	467.625	9 KHz – 6 GHz	<-20		
TM3	Ch1	460.125	9 KHz – 6 GHz	<-13	-13	PASS
	Ch8	463.625	9 KHz – 6 GHz	<-13		
	Ch16	467.625	9 KHz – 6 GHz	<-13		

Remark:

1. Measured at TM1 to TM4, recorded worst case at TM1 and TM3;

2. Please refer to following plot.

Spurious Emission on Antenna Port
TM1 / Channel 1 / 460.125 MHz

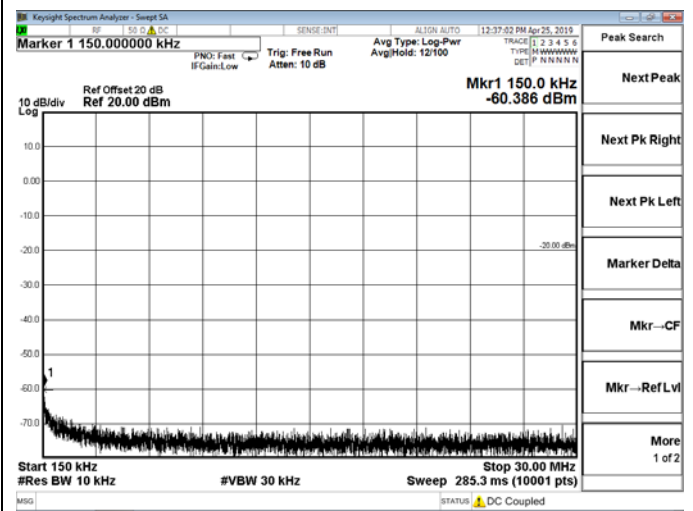
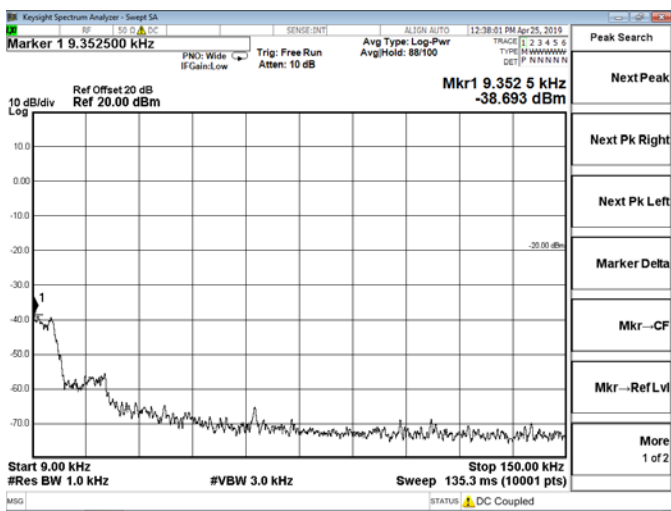

9 KHz – 150 KHz

150 KHz – 30 MHz

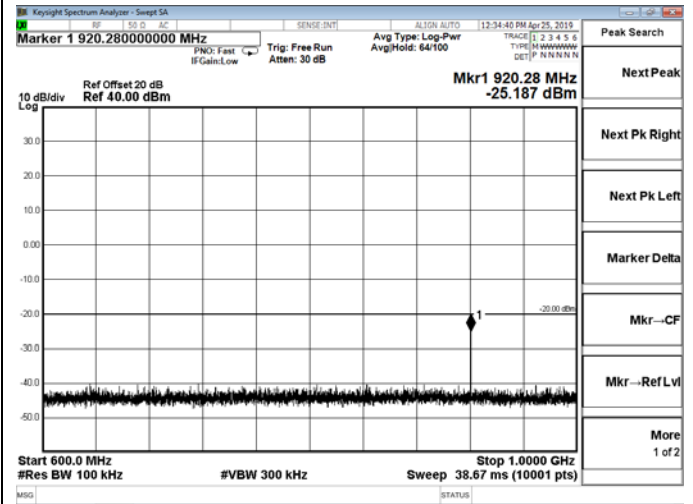
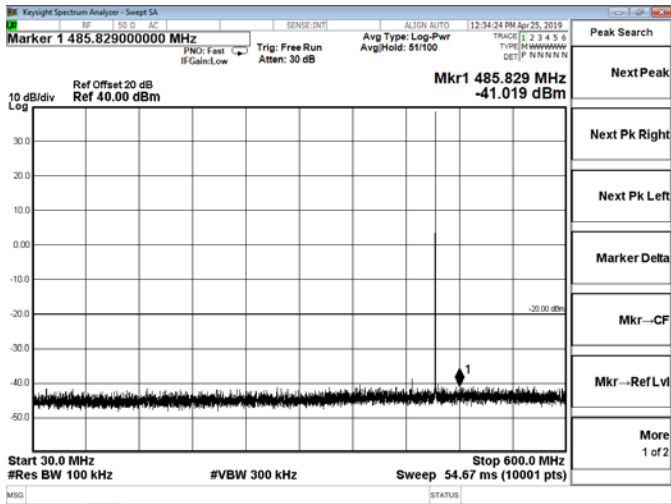

30 MHz – 600 MHz

600 MHz – 1000 MHz

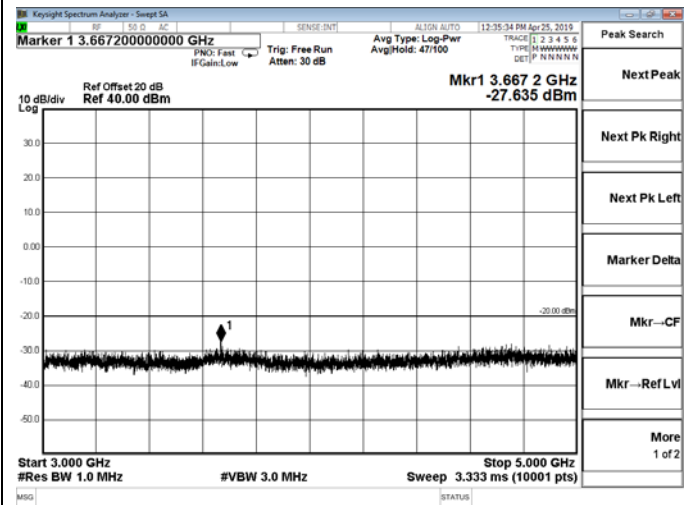
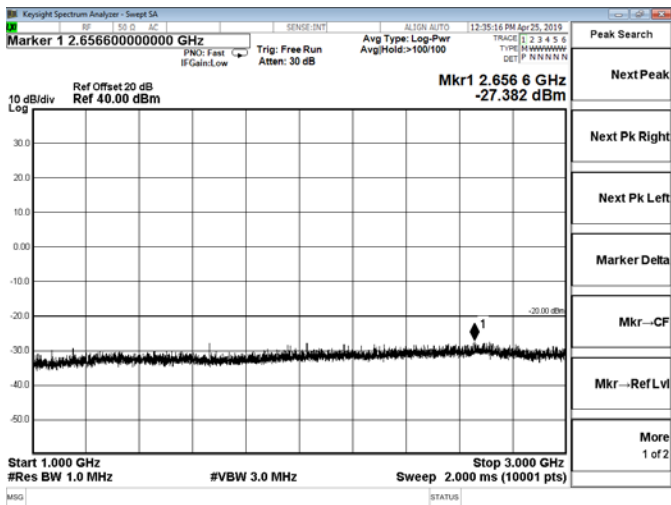

1 GHz – 3 GHz

3 GHz – 5 GHz

Spurious Emission on Antenna Port TM1 / Channel 8 / 463.625 MHz

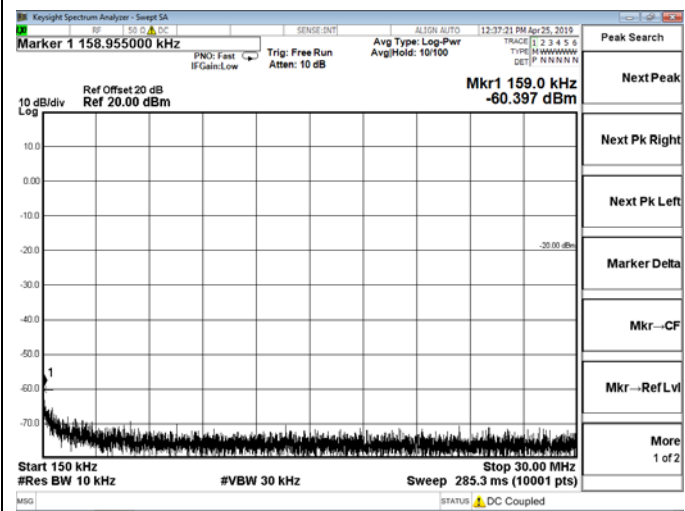
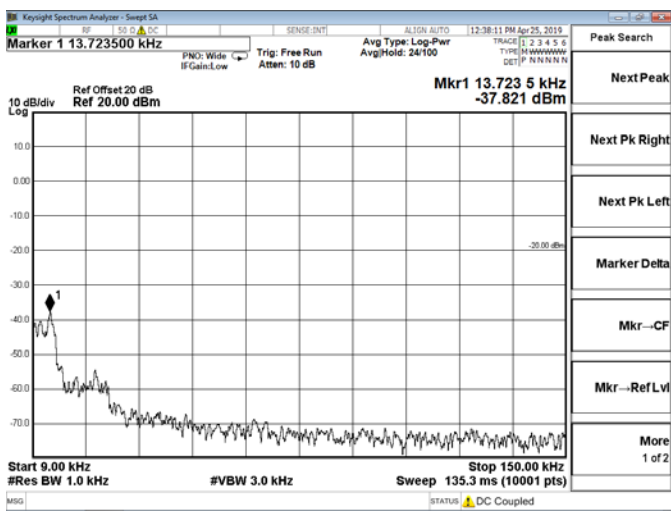

9 KHz – 150 KHz

150 KHz – 30 MHz

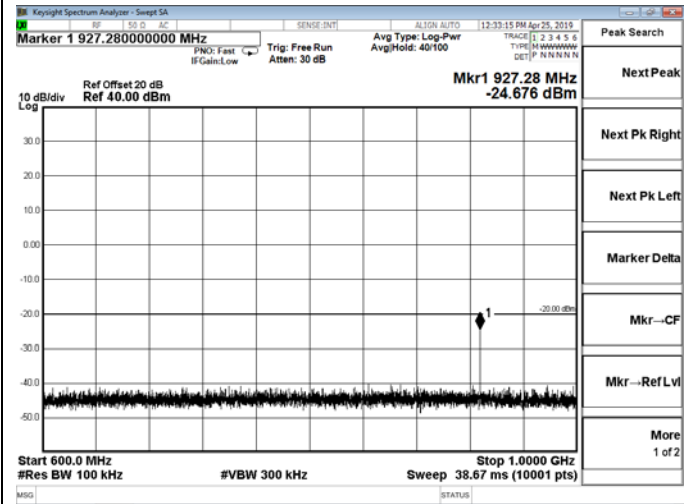
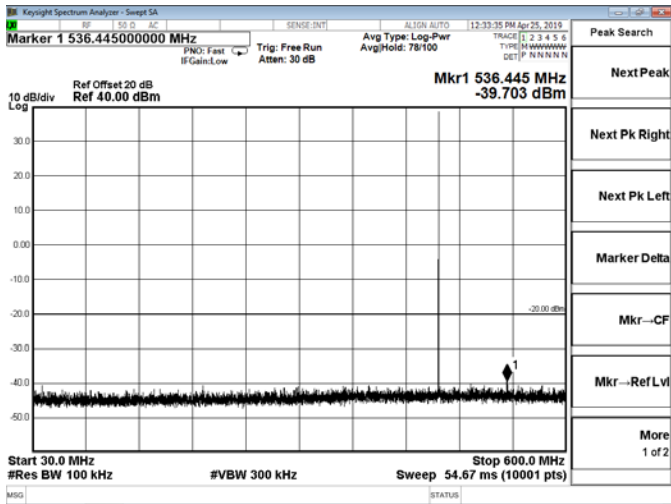

30 MHz – 600 MHz

600 MHz – 1000 MHz

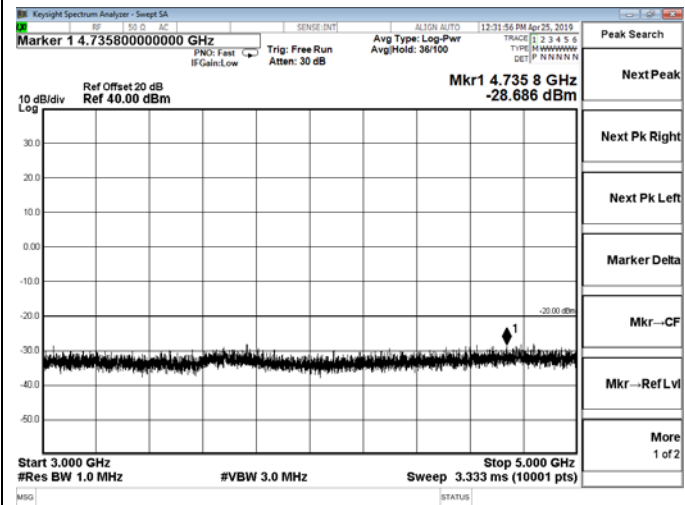
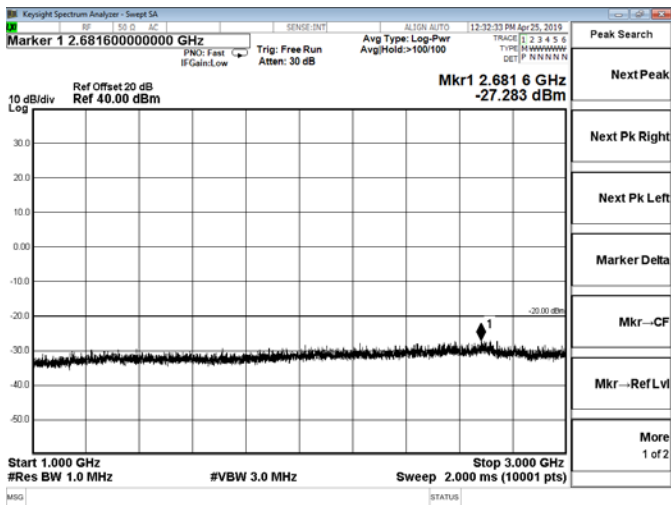

1 GHz – 3 GHz

3 GHz – 5 GHz

Spurious Emission on Antenna Port
TM1 / Channel 16 / 467.625 MHz

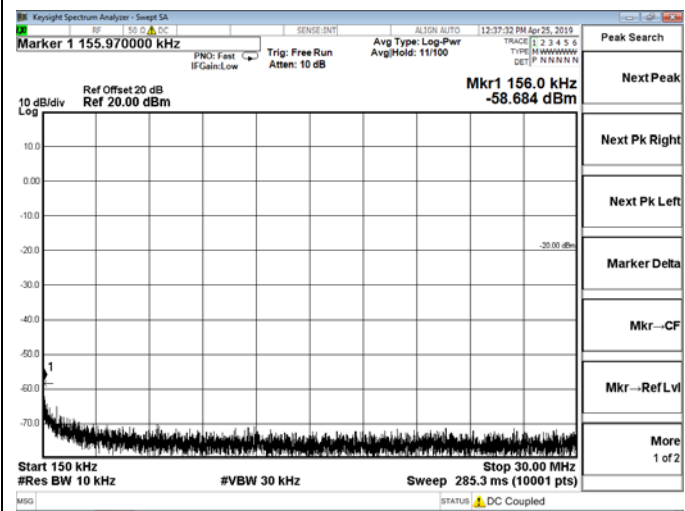
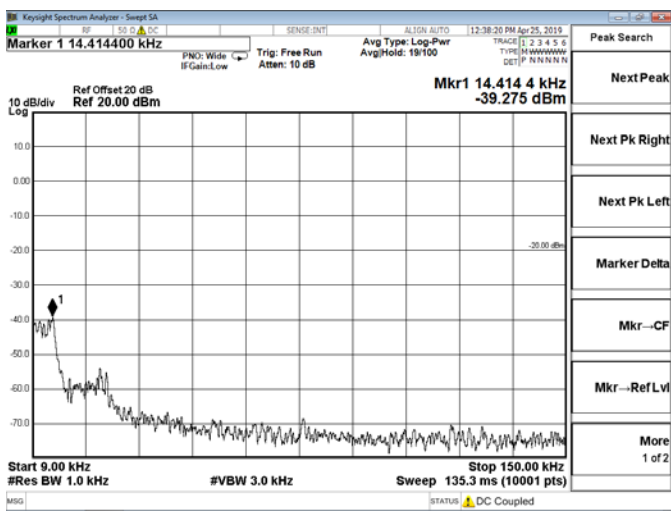

9 KHz – 150 KHz

150 KHz – 30 MHz

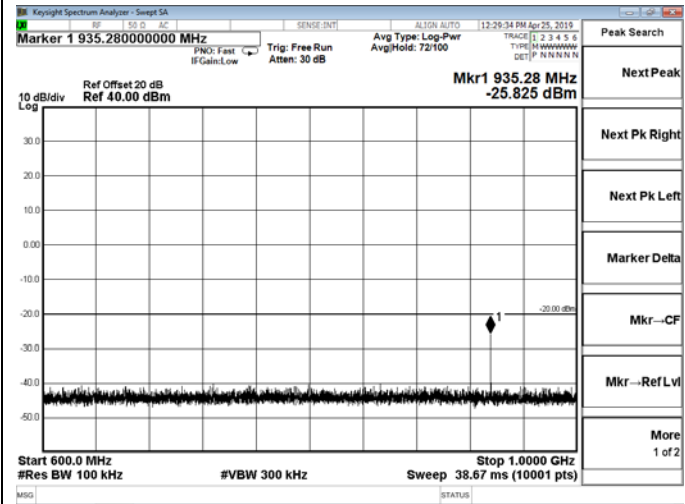
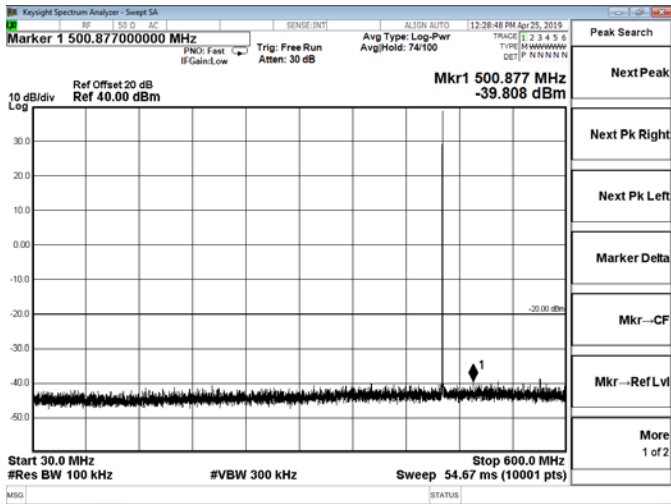

30 MHz – 600 MHz

600 MHz – 1000 MHz

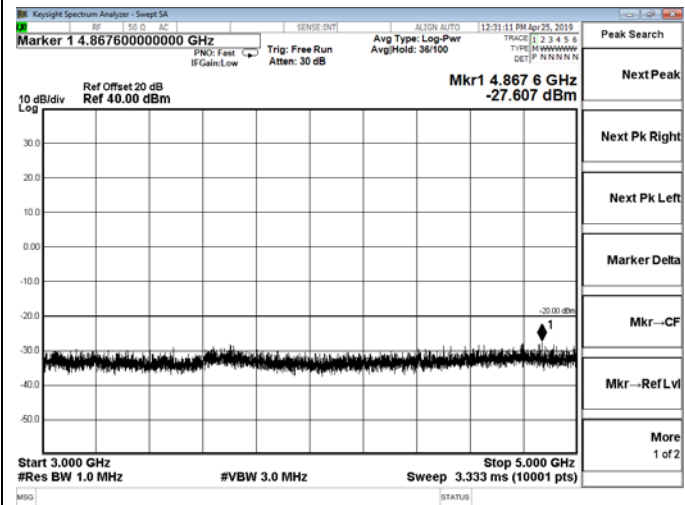
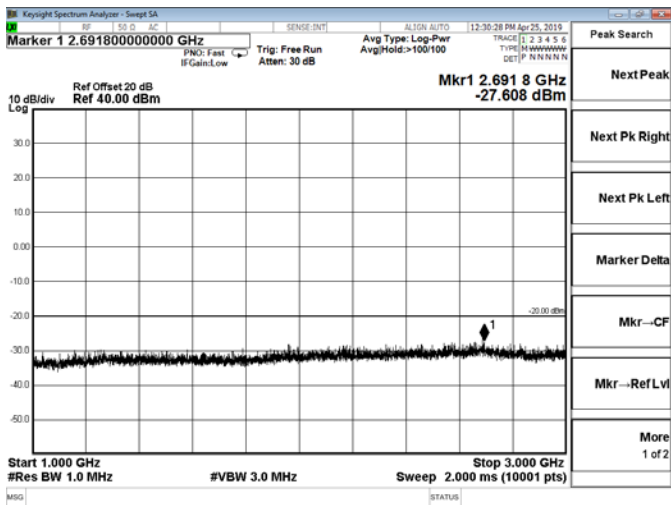

1 GHz – 3 GHz

3 GHz – 5 GHz

Spurious Emission on Antenna Port
TM3 / Channel 1 / 460.125 MHz

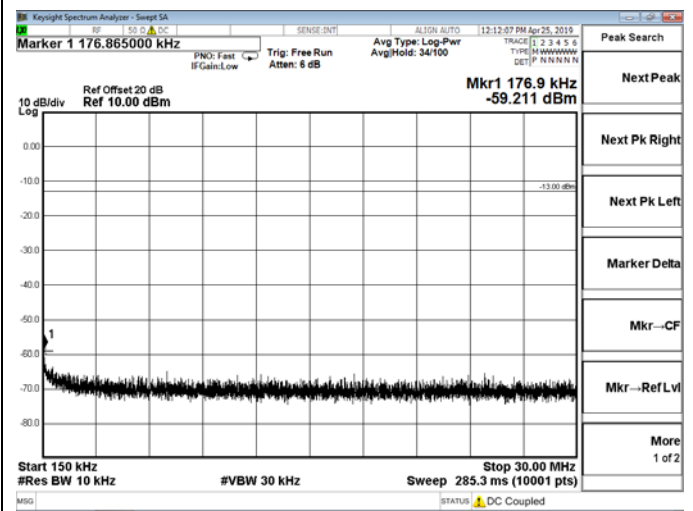
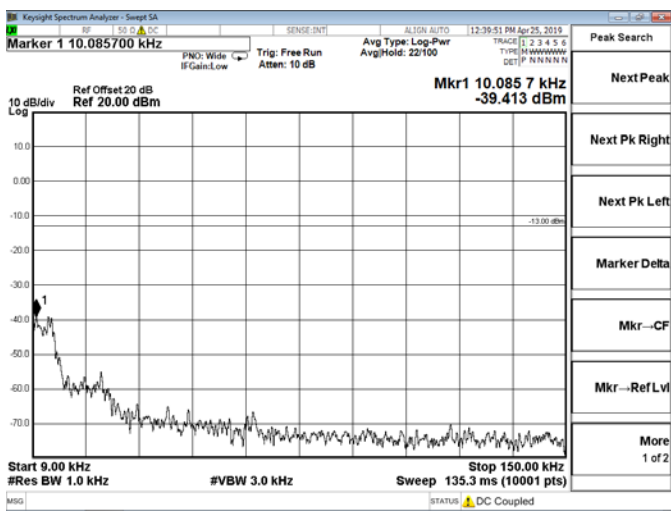

9 KHz – 150 KHz

150 KHz – 30 MHz

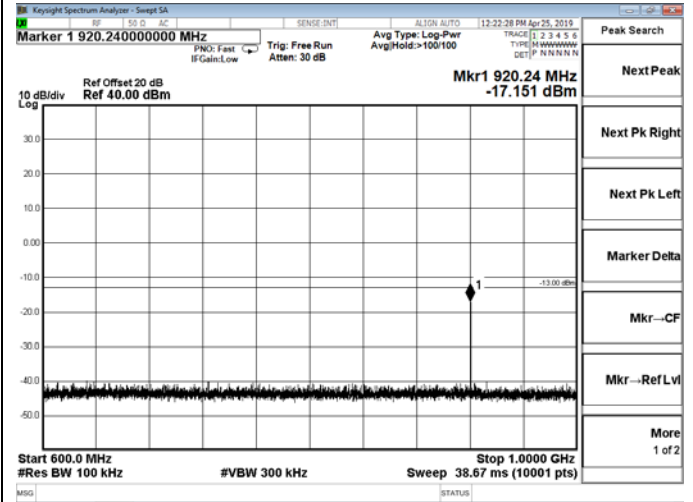
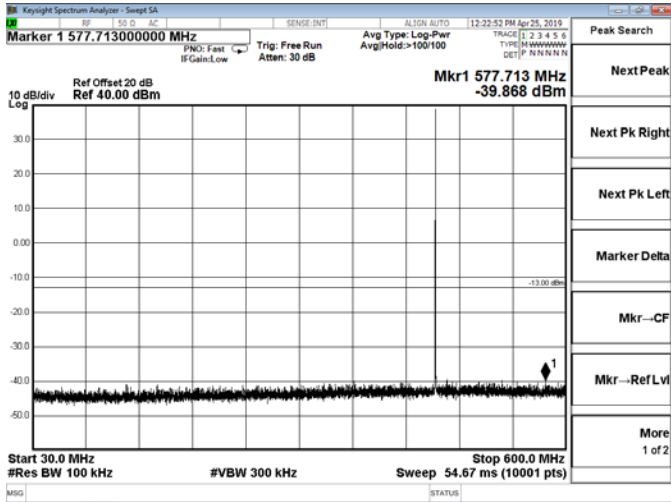

30 MHz – 600 MHz

600 MHz – 1000 MHz

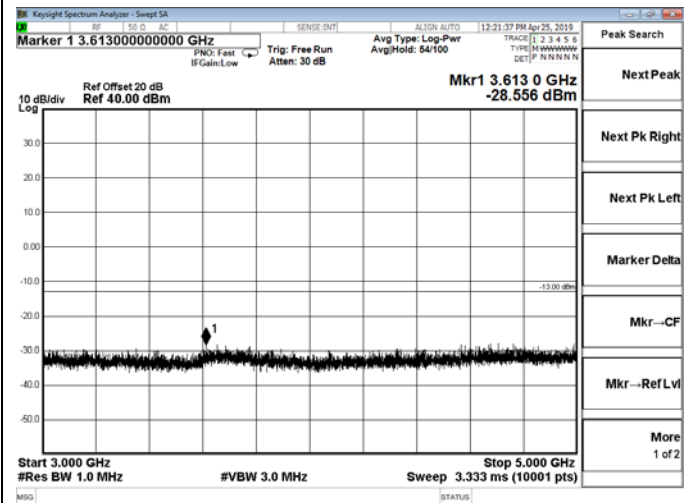
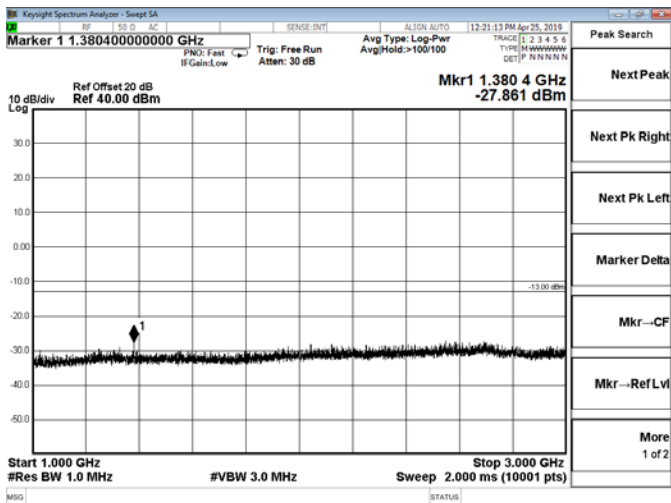

1 GHz – 3 GHz

3 GHz – 5 GHz

Spurious Emission on Antenna Port
TM3 / Channel 8 / 463.625 MHz

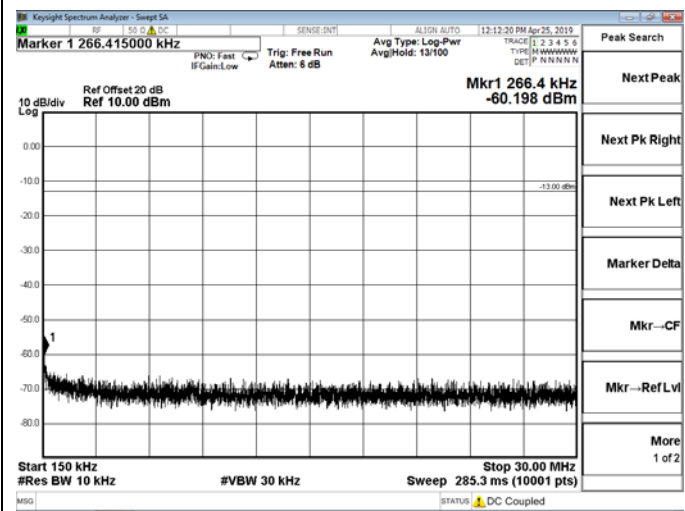
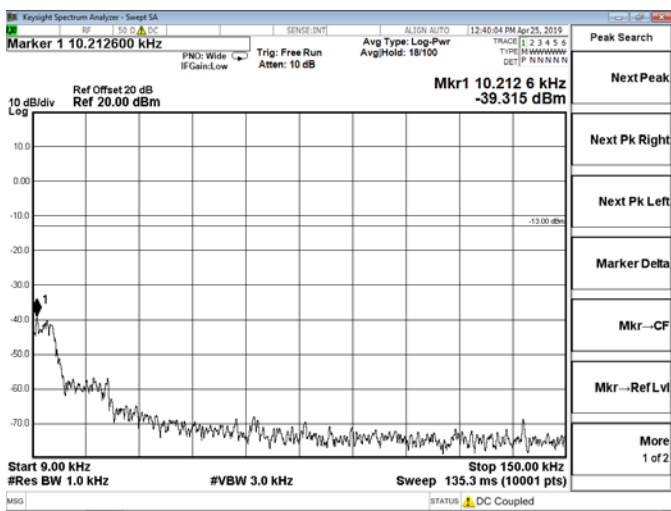

9 KHz – 150 KHz

150 KHz – 30 MHz

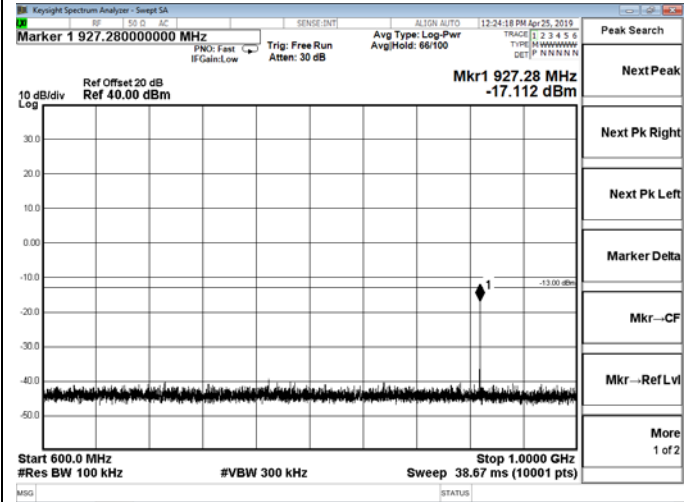
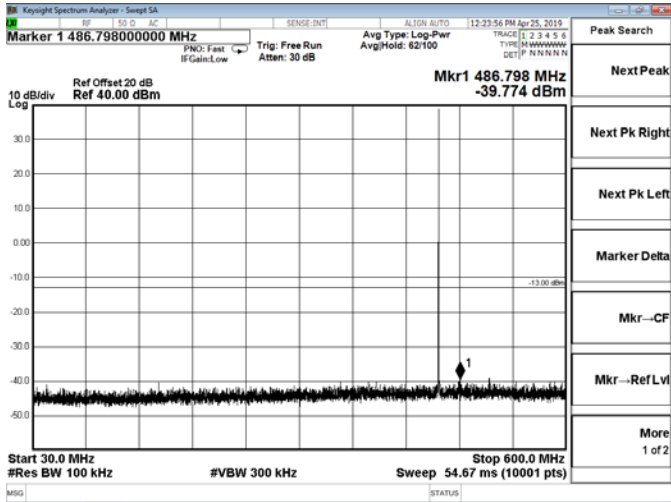

30 MHz – 600 MHz

600 MHz – 1000 MHz

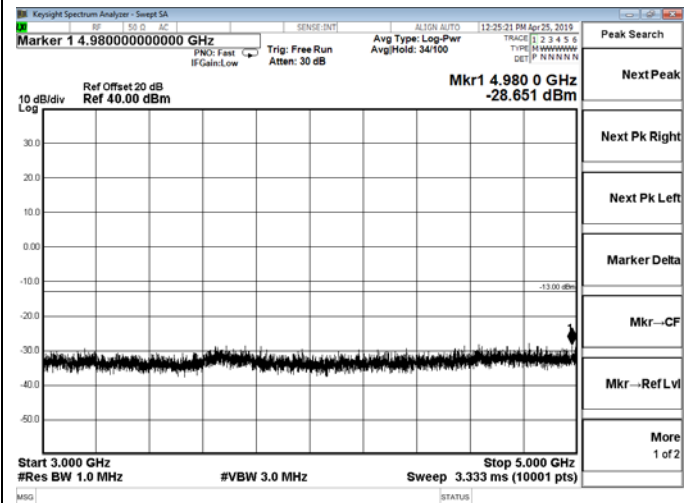
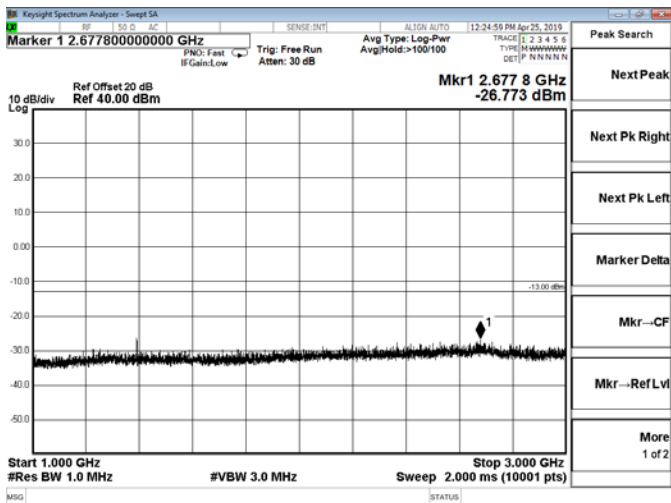

1 GHz – 3 GHz

3 GHz – 6 GHz

Spurious Emission on Antenna Port TM3 / Channel 16 / 467.625 MHz

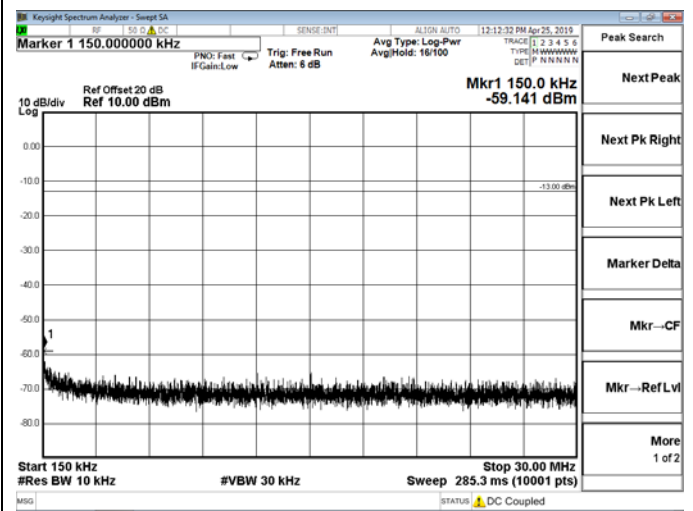
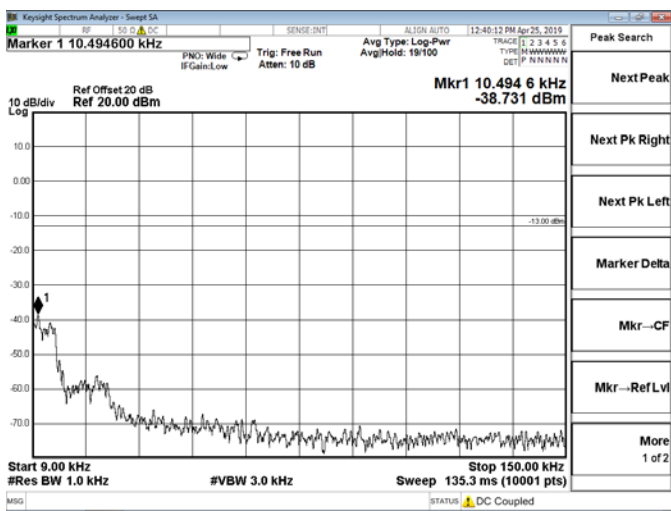

9 KHz – 150 KHz

150 KHz – 30 MHz

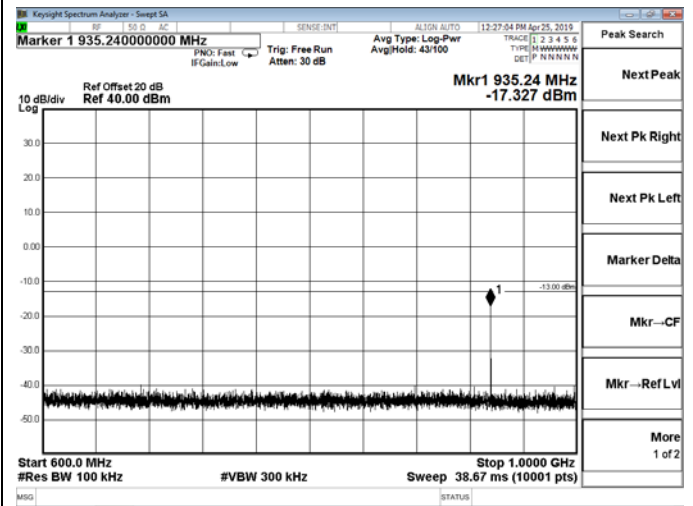
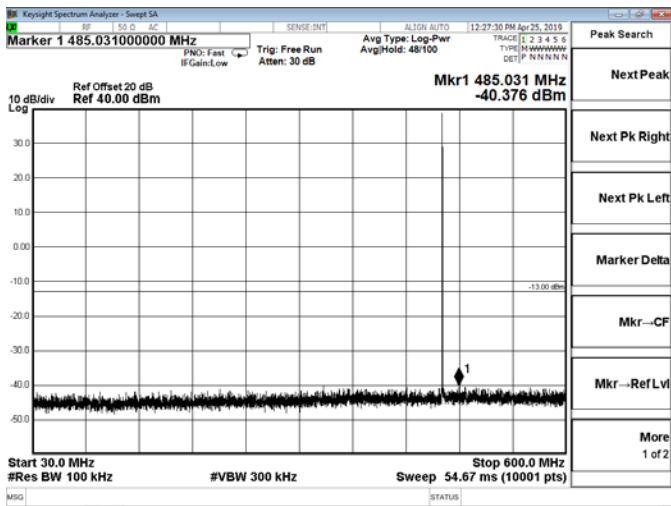

30 MHz – 600 MHz

600 MHz – 1000 MHz

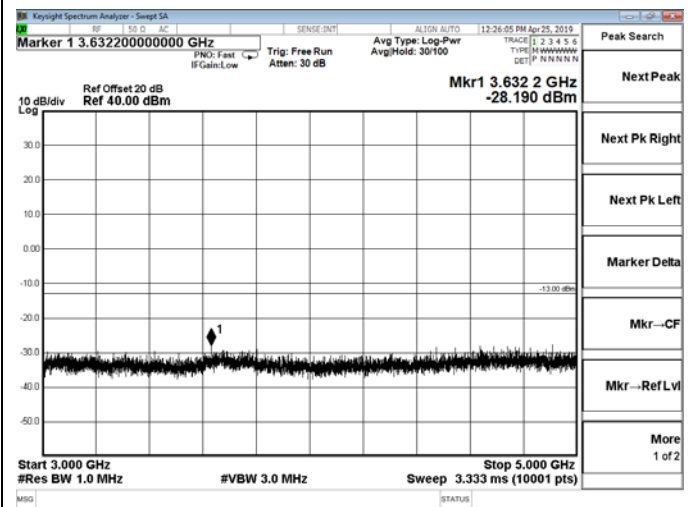
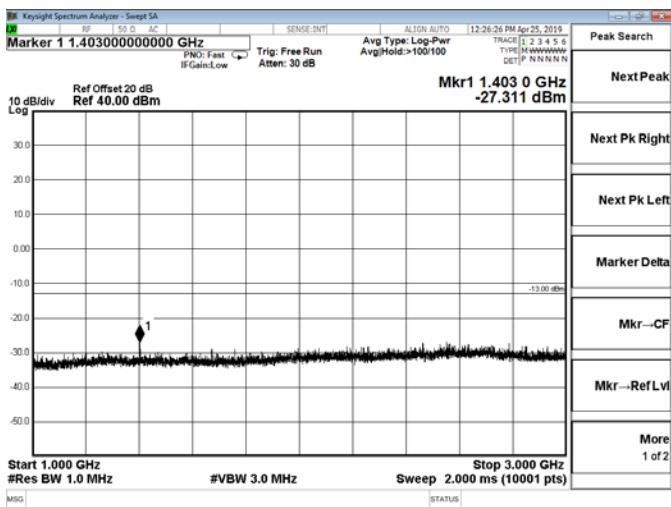

1 GHz – 3 GHz

3 GHz – 5 GHz

5.5. Modulation Characteristics - Modulation Limiting

5.5.1 Test Applicable

§ 2.1047(b): Equipment which employs modulation limiting. A curve or family of curves showing the percentage of modulation versus the modulation input voltage shall be supplied. The information submitted shall be sufficient to show modulation limiting capability throughout the range of modulating frequencies and input modulating signal levels employed.

Recommended frequency deviation characteristics are given below:

- 1.25 kHz for 6.25 kHz Channel Spacing System
- 2.5 KHz for 12.5 kHz Channel Spacing System
- 5 kHz for 25 kHz Channel Spacing System

5.5.2 Test Procedure

For Audio Transmitter: The carrier frequency deviation was measured with the tone input signal level varied from 0 Vp to audio input rating level plus 16 dB at frequencies 0.1, 0.5, 1.0, 3.0 and 5.0 kHz. The maximum deviation was recorded at each test condition.

For Data Transmitter with Maximum Frequency Deviation set by Factory: The EUT was set at maximum frequency deviation, and its peak frequency deviation was then measured using EUT's internal random data source.

5.5.3 Test Configuration

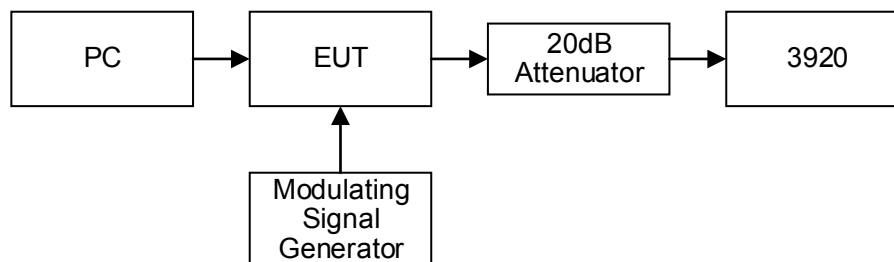

5.5.4 Test Results

Temperature	23.8°C	Humidity	52.9%
Test Engineer	Mina Xu	Test Voltage	Normal Voltage

Data Modulation Limiting for 12.5 kHz Channel Spacing Operation

Operating Mode	Data Rate	Peak Frequency Deviation (KHz)
GMSK	9.6 kbps random data	1.56

Data Modulation Limiting for 25 kHz Channel Spacing Operation

Operating Mode	Data Rate	Peak Frequency Deviation (KHz)
GMSK	19.2 kbps random data	2.33

5.6. Frequency Stability Test

5.6.1 Test Applicable

- 1 According to FCC Part 2 Section 2.1055 (a) (1), the frequency stability shall be measured with variation of ambient temperature from -30°C to +60°C centigrade.
- 2 According to FCC Part 2 Section 2.1055 (e) (2), for battery powered equipment, the frequency stability shall be measured with reducing primary supply voltage to the battery operating end point, which is specified by the manufacture.
- 3 Vary primary supply voltage from 85 to 115 percent of the nominal value.
- 4 According to §90.213, the frequency stability limit is 2.5 ppm for 12.5KHz and 5.0ppm for 25KHz channel separation

5.6.2 Test Procedure

The EUT was set in the climate chamber and connected to an external DC power supply and AC power supply. The RF output was directly connected to Spectrum Analyzer ESCI3. The coupling loss of the additional cables was recorded and taken in account for all the measurements. After temperature stabilization (approx. 20 min for each stage), the frequency for the lower, the middle and the highest frequency range was recorded. For Frequency stability Vs. Voltage the EUT was connected to a DC power supply or AC power supply and the voltage was adjusted in the required ranges. The result was recorded.

5.6.3 Test Configuration

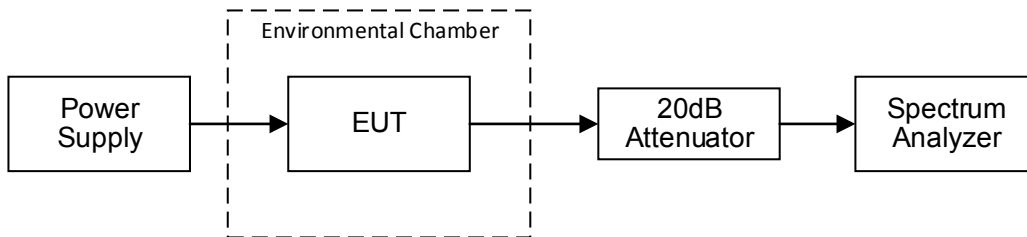

5.6.4 Test Limits

According to 90.213, Transmitters used must have minimum frequency stability as specified in the following table.

Frequency Range	Channel Bandwidth	Frequency Tolerance (ppm)		
		Fixed and Base Station	Mobile Stations	
			> 2W	≤ 2W
150-174MHz	6.25	1.0	2.0	2.0
	12.5	2.5	5.0	5.0
	25	5.0	5.0	50.0*
421-512MHz	6.25	0.5	1.0	1.0
	12.5	1.5	2.5	2.5
	25	2.5	5.0	5.0

* Stations operating in the 154.45 MHz or the 173.2 to 173.4 MHz bands must have a frequency stability of 5 ppm.

* Paging transmitters operating on paging-only frequencies must operate with frequency stability of 5 ppm in the 150-174 MHz band and 2.5 ppm in the 421-512 MHz band.

5.6.5 Test Results

Temperature	23.8°C	Humidity	52.9%
Test Engineer	Mina Xu	Test Voltage	Normal Voltage

Operation Mode	Channel Separation	Test conditions		Frequency error (ppm)		
		Voltage(V)	Temp(°C)	460.125	463.625	467.625
TM1	12.5KHz	7.4 V	-30	0.83	0.24	0.39
			-20	0.17	0.93	0.50
			-10	0.97	0.52	0.99
			0	0.42	0.60	0.36
			10	0.76	0.52	0.66
			20	0.22	0.18	0.64
			30	0.21	0.75	0.39
			40	0.68	0.51	0.19
			50	0.86	0.16	0.41
			6.29 (85% Rated)	20	0.57	0.00
		8.51(115% Rated)	20	0.42	0.85	0.38
Limit			2.5 ppm			
Test Results			PASS			

Operation Mode	Channel Separation	Test conditions		Frequency error (ppm)		
		Voltage(V)	Temp(°C)	460.125	463.625	467.625
TM3	25KHz	7.4 V	-30	0.57	0.81	0.37
			-20	0.61	0.33	0.56
			-10	0.13	0.35	0.49
			0	0.55	0.03	0.31
			10	0.75	0.70	0.09
			20	1.00	0.95	0.30
			30	0.90	0.64	0.41
			40	0.41	0.77	0.32
			50	0.56	0.53	0.08
			6.29 (85% Rated)	20	0.82	0.02
		8.51(115% Rated)	20	0.72	0.85	0.25
Limit			5.0 ppm			
Test Results			PASS			

Remark:

1. Measured at TM1 to TM4, recorded worst case at TM1 and TM3.

5.7. Transmitter Frequency Behavior

5.7.1 Test Applicable

Section 90.214

Transient frequencies must be within the maximum frequency difference limits during the time intervals indicated:

Time intervals ^{1,2}	Maximum frequency difference ³	All equipment	
		1500 to 174 MHz	421 to 512 MHz
Transient Frequency Behavior for Equipment Designed to Operate on 25KHz Channels			
t ₁ ⁴	± 25.0KHz	5.0ms	10.0ms
t ₁	± 12.5KHz	20.0ms	25.0ms
t ₃ ⁴	± 25.0KHz	5.0ms	10.0ms
Transient Frequency Behavior for Equipment Designed to Operate on 12.5KHz Channels			
t ₁ ⁴	±12.5KHz	5.0ms	10.0ms
t ₁	± 6.25KHz	20.0ms	25.0ms
t ₃ ⁴	± 12.5KHz	5.0ms	10.0ms
Transient Frequency Behavior for Equipment Designed to Operate on 6.25KHz Channels			
t ₁ ⁴	±6.25KHz	5.0ms	10.0ms
t ₁	± 3.125KHz	20.0ms	25.0ms
t ₃ ⁴	± 6.25KHz	5.0ms	10.0ms

- t_{on} is the instant when a 1 KHz test signal is completely suppressed, including any capture time due to phasing.
t₁ is the time period immediately following t_{on}.
t₂ is the time period immediately following t₁.
t₃ is the time period from the instant when the transmitter is turned off until t_{off}.
t_{off} is the instant when 1 KHz test signal starts to rise.
- During the time from the end of t₂ to the beginning of t₃, the frequency difference must not exceed the limits specified in 90.213.
- Difference between the actual transmitter frequency and the assigned transmitter frequency.
- If the transmitter carrier output power rating is 6 watts or less, the frequency difference during this time period may exceed the maximum frequency for this time period.

5.7.2 Test Configuration

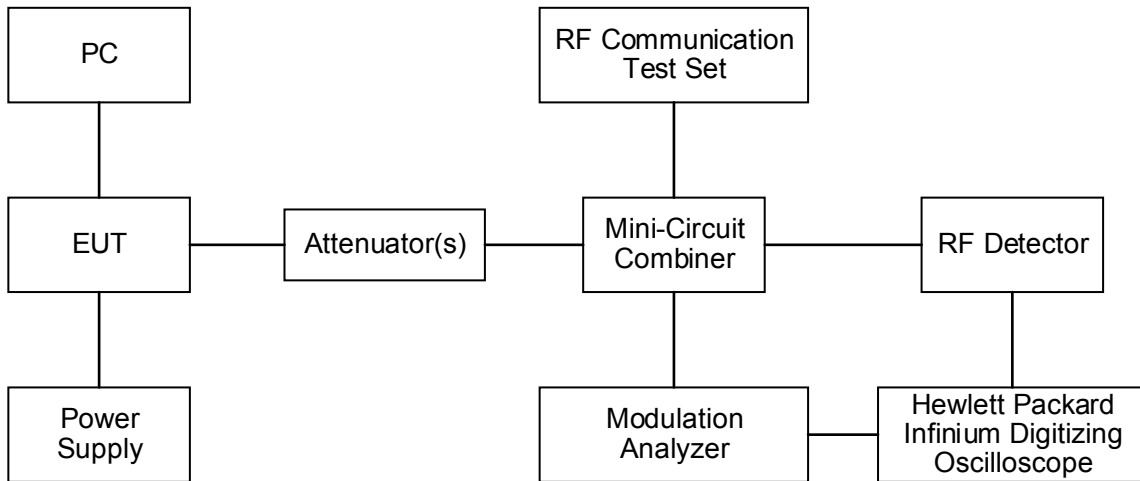

5.7.3 Test Procedure

According to TIA/EIA-603 2.2.19 requirement.

5.7.4 Test Results

Temperature	23.8°C	Humidity	52.9%
Test Engineer	Mina Xu	Test Voltage	Normal Voltage

Measured at TM1 to TM4, recorded worst case at TM1 and TM3.

Modulation Type: GMSK

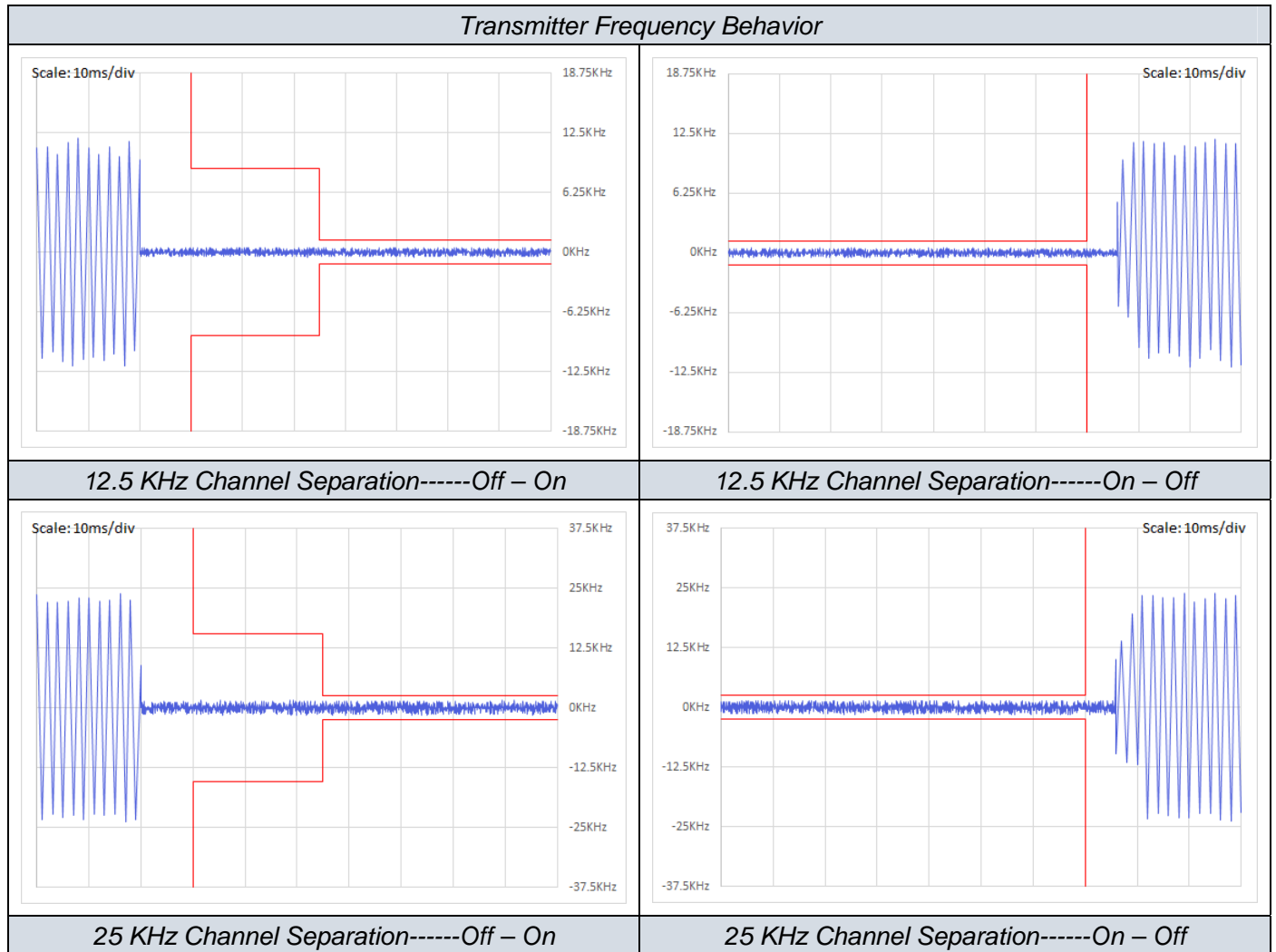

6. LIST OF MEASURING EQUIPMENT

Item	Equipment	Manufacturer	Model No.	Serial No.	Cal Date	Due Date
1	Power Meter	R&S	NRVS	100444	2018-06-16	2019-06-15
2	Power Sensor	R&S	NRV-Z81	100458	2018-06-16	2019-06-15
3	Power Sensor	R&S	NRV-Z32	10057	2018-06-16	2019-06-15
4	ESG Vector Signal Generator	Agilent	E4438C	MY49072627	2018-06-16	2019-06-15
5	MXA Signal Analyzer	Agilent	N9020A	MY50510140	2018-06-16	2019-06-15
6	DC Power Supply	Agilent	E3642A	N/A	2018-11-15	2019-11-14
7	EMI Test Software	AUDIX	E3	N/A	N/A	N/A
8	3m Semi Anechoic Chamber	SIDT FRANKONIA	SAC-3M	03CH03-HY	2018-06-16	2019-06-15
9	Positioning Controller	MF	MF-7082	N/A	2018-06-16	2019-06-15
10	Active Loop Antenna	SCHWARZBECK	FMZB 1519B	00005	2018-07-26	2019-07-25
11	By-log Antenna	SCHWARZBECK	VULB9163	9163-470	2018-07-26	2019-07-25
12	Horn Antenna	SCHWARZBECK	BBHA 9120D	9120D-1925	2018-07-02	2019-07-01
13	Broadband Horn Antenna	SCHWARZBECK	BBHA 9170	791	2018-09-20	2019-09-19
14	Broadband Preamplifier	SCHWARZBECK	BBV 9719	9719-025	2018-09-20	2019-09-19
15	EMI Test Receiver	R&S	ESR 7	101181	2018-06-16	2019-06-15
16	RS SPECTRUM ANALYZER	R&S	FSP40	100503	2018-11-15	2019-11-14
17	AMPLIFIER	QuieTek	QTK	CHM/0809065	2018-11-15	2019-11-14
18	RF Cable-R03m	Jye Bao	RG142	CB021	2018-06-16	2019-06-15
19	RF Cable-HIGH	SUHNER	SUCOFLEX 106	03CH03-HY	2018-06-16	2019-06-15
20	6dB Attenuator	/	100W/6dB	1172040	2018-06-16	2019-06-15
21	3dB Attenuator	/	2N-3dB	/	2018-06-16	2019-06-15
22	EMI Test Receiver	R&S	ESPI	101840	2018-06-16	2019-06-15
23	Artificial Mains	R&S	ENV216	101288	2018-06-16	2019-06-15
24	10dB Attenuator	SCHWARZBECK	MTS-IMP-136	261115-001-0032	2018-06-16	2019-06-15
25	Combiner	eastsheep	SHWLPD2-52 500S	/	2018-11-15	2019-11-14
26	Audio Analyzer	R&S	UPV	1146.2003K02-10 1721-UW	2018-11-15	2019-11-14
27	Storage Oscilloscope	Tektronix	TDS3054B	B033154	2018-06-16	2019-06-15
28	Digital Communication Test Set	Aeroflex	3920	100245	2018-06-16	2019-06-15
29	RF Communication Test Set	HP	8920A	3813A10245	2018-06-16	2019-06-15
30	Signal Generator	R&S	SMR40	10016	2018-06-16	2019-06-15
31	High-Pass Filter	Anritsu	MP526B	6220875288	2018-06-16	2019-06-15
32	High-Pass Filter	Anritsu	MP526D	6220878442	2018-06-16	2019-06-15

Note: All equipment is calibrated through GUANGZHOU LISAI CALIBRATION AND TEST CO.,LTD.

7. TEST SETUP PHOTOGRAPHS OF EUT

Please refer to separated files for Test Setup Photos of the EUT.

8. EXTERIOR PHOTOGRAPHS OF THE EUT

Please refer to separated files for External Photos of the EUT.

9. INTERIOR PHOTOGRAPHS OF THE EUT

Please refer to separated files for Internal Photos of the EUT.

-----THE END OF REPORT-----