

FCC PART 27 TEST REPORT**FCC Part 27****Report Reference No.**.....: **LCS190306003AEF****FCC ID**.....: **2AJTU-K5****Date of Issue**.....: **April 24, 2019****Testing Laboratory Name**.....: **Shenzhen LCS Compliance Testing Laboratory Ltd.**Address.....: 1/F., Xingyuan Industrial Park, Tongda Road, Bao'an Avenue,
Bao'an District, Shenzhen, Guangdong, China**Applicant's name**.....: **South Surveying & Mapping Technology Co., Ltd.**

Address.....: No.39, Sicheng Road, Tianhe District, Guangzhou, China

Test specification.....:**FCC CFR Title 47 Part 2, Part 27**Standard.....: **ANSI/TIA-603-E-2016****KDB 971168 D01 v03r01**

Test Report Form No.....: LCSEMC-1.0

TRF Originator.....: Shenzhen LCS Compliance Testing Laboratory Ltd.

Master TRF.....: Dated 2011-03

Shenzhen LCS Compliance Testing Laboratory Ltd. All rights reserved.

This publication may be reproduced in whole or in part for non-commercial purposes as long as the Shenzhen LCS Compliance Testing Laboratory Ltd. is acknowledged as copyright owner and source of the material. Shenzhen LCS Compliance Testing Laboratory Ltd. takes no responsibility for and will not assume liability for damages resulting from the reader's interpretation of the reproduced material due to its placement and context.

Test item description.....: **GNSS RECEIVER**

Trade Mark.....: SOUTH, KOLIDA, SANDING, RUIDE, TIANYU

Model/Type reference.....: K5

Listed Models.....: K3, K9, R90i, R8i, C1, T3, T5, H3 plus, A20, M6

Modulation Type.....: QPSK, 16QAM

Rating.....: DC 7.4V by Rechargeable Li-ion Battery(3400mAh) or
DC 13.8V by external power
Recharged by DC 4.2V 1.35A or DC 8.4V/0.67A for battery

Hardware version.....: SG3000001

Software version.....: GalaxyRTK_LWB-V20181210

Frequency.....: TDD Band 38, TDD Band 39, TDD Band 40, TDD Band 41

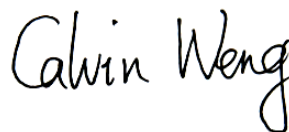
Result.....: **PASS****Compiled by:****Supervised by:****Approved by:**

Aking Jin/File administrator

Calvin Weng/Technique principal

Gavin Liang/ Manager

TEST REPORT**Test Report No. :****LCS190306003AEF**

April 24, 2019

Date of issue

Equipment under Test : **GNSS RECEIVER**

Model /Type : K5

Listed Models : K3, K9, R90i, R8i, C1, T3, T5, H3 plus, A20, M6

Model Declaration : PCB board, structure and internal of these model(s) are the same, so no additional models were tested

Applicant : **South Surveying & Mapping Technology Co., Ltd.**
Address : No.39, Sicheng Road, Tianhe District, Guangzhou, China

Manufacturer : **South Surveying & Mapping Technology Co., Ltd.**
Address : No.39, Sicheng Road, Tianhe District, Guangzhou, China

Factory : **South Surveying & Mapping Technology Co., Ltd.**
Address : No.39, Sicheng Road, Tianhe District, Guangzhou, China

Test Result:**PASS**

The test report merely corresponds to the test sample.
It is not permitted to copy extracts of these test result without the written permission of the test laboratory.

Revision History

Revision	Issue Date	Revisions	Revised By
000	April 24, 2019	Initial Issue	Gavin Liang

Contents

<u>1</u>	<u>TEST STANDARDS.....</u>	<u>5</u>
<u>2</u>	<u>SUMMARY</u>	<u>6</u>
2.1	General Remarks	6
2.2	Product Description	6
2.3	Equipment under Test	7
2.4	Short description of the Equipment under Test (EUT)	7
2.5	Internal Identification of AE used during the test	7
2.6	Normal Accessory setting	7
2.7	EUT configuration	8
2.8	Related Submittal(s) / Grant (s)	8
2.9	Modifications	8
2.10	General Test Conditions/Configurations	8
<u>3</u>	<u>TEST ENVIRONMENT.....</u>	<u>9</u>
3.1	Address of the test laboratory	9
3.2	Test Facility	9
3.3	Environmental conditions	9
3.4	Test Description	9
3.5	Equipments Used during the Test	10
3.6	Measurement uncertainty	11
<u>4</u>	<u>TEST CONDITIONS AND RESULTS.....</u>	<u>12</u>
4.1	Output Power	12
4.2	Peak-to-Average Ratio (PAR)	16
4.3	Occupied Bandwidth and Emission Bandwidth	17
4.4	Band Edge compliance	18
4.5	Spurious Emssion on Antenna Port	19
4.6	Radiated Spurious Emssion	21
4.7	Frequency Stability under Temperature & Voltage Variations	28
<u>5</u>	<u>TEST SETUP PHOTOS OF THE EUT</u>	<u>30</u>
<u>6</u>	<u>EXTERNAL PHOTOS OF THE EUT.....</u>	<u>30</u>
<u>7</u>	<u>INTERNAL PHOTOS OF THE EUT.....</u>	<u>30</u>

1 TEST STANDARDS

The tests were performed according to following standards:

[FCC Part 22 \(10-1-17 Edition\)](#):PRIVATE LAND MOBILE RADIO SERVICES.

[FCC Part 24\(10-1-17 Edition\)](#):PUBLIC MOBILE SERVICES

[FCC Part 27\(10-1-17 Edition\)](#):MISCELLANEOUS WIRELESS COMMUNICATIONS SERVICES

[ANSI/TIA-603-E-2016](#):Land Mobile FM or PM Communications Equipment Measurement and Performance Standards.

[971168 D01 Power Meas License Digital Systems v03](#):Measurement Guidance For Certification of Licensed Digital Transmitters

[FCC Part 2](#): Frequency Allocations And Radio Treaty Matters: General Rules And Regulations.

[ANSI C63.26:2015](#):American National Standard for Compliance Testing of Transmitters Used in Licensed Radio Services.

2 SUMMARY

2.1 General Remarks

Date of receipt of test sample	:	March 06, 2019
Testing commenced on	:	March 06, 2019
Testing concluded on	:	April 19, 2019

2.2 Product Description

The **South Surveying & Mapping Technology Co., Ltd.**'s Model: K5 or the "EUT" as referred to in this report; more general information as follows, for more details, refer to the user's manual of the EUT.

Name of EUT	GNSS RECEIVER
Model No.	K3, K5, K9, R90i, R8i, C1, T3, T5, H3 plus, A20, M6
Model Declaration	PCB board, structure and internal of these model(s) are the same, so no additional models were tested
Test Model	K5
Power Supply	DC 7.4V by Rechargeable Li-ion Battery(3400mAh) or DC 13.8V by external power Recharged by DC 4.2V 1.35A or DC 8.4V/0.67A for battery
Hardware version	SG3000001
Software version	GalaxyRTK_LWB-V20181210
GSM/EDGE/GPRS Operation Frequency Band	GSM850/PCS1900/GPRS850/GPRS1900/EDGE850/EDGE1900
UMTS Operation Frequency Band	UMTS FDD Band I/V/VIII
LTE Operation Frequency Band	LTE Band 38/39/40/41
Modulation Type	GMSK for GSM/GPRS; 8-PSK for EDGE; QPSK for UMTS; QPSK, 16QAM for LTE
GSM/EDGE/GPRS	Supported GSM/GPRS/EDGE
GSM Release Version	R99
GSM/EDGE/GPRS Power Class	GSM850:Power Class 4/ PCS1900:Power Class 1
GPRS/EDGE Multislot Class	GPRS/EDGE: Multi-slot Class 12
GPRS operation mode	Class B
WCDMA Release Version	R8
HSDPA Release Version	Release 8
HSUPA Release Version	Release 8
DC-HSUPA Release Version	Not Supported
LTE Release Version	Release 9
LTE/UMTS Power Class	Class 3
Antenna Type	SMA Antenna
Antenna Gain	2.0dBi (max.) for GSM 850, PCS 1900; 2.0dBi (max.) for WCDMA Band V; 2.0dBi (max.) for LTE Band 41
BT FCC Operation frequency	2402-2480MHz
BT FCC Modulation Type	GFSK, $\pi/4$ -DQPSK, 8-DPSK for Bluetooth V4.0 (BDR/EDR) GFSK for Bluetooth V4.0 (BT LE)
Bluetooth Version	V4.0
Antenna Type	Ceramic Antenna
Antenna Gain	2.0dBi (max.) for Bluetooth
WLAN FCC Operation frequency	IEEE 802.11b/g/n HT20:2412-2462MHz
WLAN FCC Modulation Type	IEEE 802.11b: DSSS(CCK,DQPSK,DBPSK) IEEE 802.11g/n: OFDM(64QAM, 16QAM, QPSK, BPSK)
Antenna Type	Ceramic Antenna
Antenna Gain	2.0dBi (max.) for WLAN

PMR FCC Operation frequency	460.125-467.625MHz
Channel Separation	12.5KHz & 25KHz
Modulation Type	GMSK
Emission Designator	11K0G1D for GMSK Modulation at 12.5KHz Channel Separation 16K0G1D for GMSK Modulation at 25KHz Channel Separation
Rate Power	25W/10W
Antenna Type	SMA Antenna
Antenna Gain	5.0dBi (max.) for PMR
GPS function	Support and only RX
FM function	Support and only RX
NFC Function	Support and only RX
Extreme temp. Tolerance	-10°C to +55°C
Extreme Voltage Tolerance	DC 6.66V to 8.14V

2.3 Equipment under Test

Power supply system utilised

Power supply voltage	:	<input type="radio"/> 120V/ 60 Hz	<input type="radio"/> 115V/60Hz
		<input type="radio"/> 12 V DC	<input type="radio"/> 24 V DC
		<input checked="" type="radio"/> Other (specified in blank below)	

DC 7.40V

2.4 Short description of the Equipment under Test (EUT)

2.4.1 GeneralDescription

K5 is subscriber equipment in the LTE/WCDMA/GSM system. The HSPA/UMTS frequency band is Band II/IV/V, LTE frequency band is band 41. The GSM/GPRS/EDGE frequency band includes GSM850 and PCS1900. The K5 implements such functions as RF signal receiving/transmitting, HSPA/UMTS and GSM/GPRS/EDGE protocol processing. Externally it provides SIM card interface.

NOTE: Unless otherwise noted in the report, the functional boards installed in the units shall be selected from the below list, but not means all the functional boards listed below shall be installed in one unit.

2.5 Internal Identification of AE used during the test

AE ID*	Description
AE1	Battery (3400mAh)
AE2	N/A

*AE ID: is used to identify the test sample in the lab internally.

2.6 Normal Accessory setting

Fully charged battery was used during the test.

2.7 EUT configuration

The following peripheral devices and interface cables were connected during the measurement:

● - supplied by the manufacturer

○ - supplied by the lab

<input type="radio"/>	Power Cable	Length (m) :	/
		Shield :	/
		Detachable :	/
<input type="radio"/>	Multimeter	Manufacturer :	/
		Model No. :	/

2.8 Related Submittal(s) / Grant (s)

This submittal(s) (test report) is intended for **FCC ID:2AJTU-K5** filing to comply with FCC Part 22, Part 24&FCC Part 27 Rules

2.9 Modifications

No modifications were implemented to meet testing criteria.

2.10 General Test Conditions/Configurations

2.10.1 Test Environment

EnvironmentParameter	SelectedValuesDuringTests	
Relative Humidity	Ambient	
Temperature	TN	Ambient
Voltage	VL	6.66V
	VN	7.40V
	VH	8.14V

NOTE:VL=lower extreme testvoltageVN=nominalvoltage
VH=upperextreme testvoltageTN=normaltemperature

3 TEST ENVIRONMENT

3.1 Address of the test laboratory

Shenzhen LCS Compliance Testing Laboratory Ltd

1/F., Xingyuan Industrial Park, Tongda Road, Bao'an Avenue, Bao'an District, Shenzhen, Guangdong, China

The sites are constructed in conformance with the requirements of ANSI C63.4 (2014) and CISPR Publication 22.

3.2 Test Facility

The test facility is recognized, certified, or accredited by the following organizations:

FCC Registration Number is 254912.
 Industry Canada Registration Number is 9642A-1.
 EMSD Registration Number is ARCB0108.
 UL Registration Number is 100571-492.
 TUV SUD Registration Number is SCN1081.
 TUV RH Registration Number is UA 50296516-001.
 NVLAP Accreditation Code is 600167-0.
 FCC Designation Number is CN5024.
 CAB identifier is CN0071.

3.3 Environmental conditions

During the measurement the environmental conditions were within the listed ranges:

Temperature:	15-35 ° C
Humidity:	30-60 %
Atmospheric pressure:	950-1050mbar

3.4 Test Description

3.4.1 BRS/EBS Band (2496-2690MHz paired with 2496-2690MHz)

Test Item	FCC RuleNo.	Requirements	Verdict
Effective (Isotropic) Radiated Power Output Data	§2.1046, §27.50(h)	EIRP ≤ 2W;	Pass
Peak-Average Ratio	§2.1046, §27.50	Limits≤13dB	Pass
Modulation Characteristics	§2.1047	Digitalmodulation	N/A
Bandwidth	§2.1049	OBW: Nolimit. EBW: Nolimit.	Pass
Band Edges Compliance	§2.1051, §27.53(m)	≤ -13dBm/1%*EBW, in 1 MHz bands immediately outside and adjacent to The frequency block.	Pass
Spurious Emission at Antenna Terminals	§2.1051, §27.53(m)	≤ -13dBm/1MHz, from 9kHz to 10th harmonics but outside authorized Operating frequency ranges.	Pass
Frequency Stability	§2.1055, §27.54	Within authorized bands of operation/frequency block.	Pass
Radiated spurious emission	§2.1053, §27.53(m)	≤ -13dBm/1MHz.	Pass

NOTE 1: For the verdict, the "N/A" denotes "not applicable", the "N/T" de notes "not tested"

3.5 Equipments Used during the Test

Item	Equipment	Manufacturer	Model No.	Serial No.	Cal Date	Due Date
1	Power Meter	R&S	NRVS	100444	2018-06-16	2019-06-15
2	Power Sensor	R&S	NRV-Z81	100458	2018-06-16	2019-06-15
3	Power Sensor	R&S	NRV-Z32	10057	2018-06-16	2019-06-15
4	LTE Test Software	Tonscend	JS1120-1	N/A	N/A	N/A
5	RF Control Unit	Tonscend	JS0806	158060009	2018-06-16	2019-06-15
6	MXA Signal Analyzer	Agilent	N9020A	MY51250905	2018-11-15	2019-11-14
7	WIDEBAND RADIO COMMUNICATION TESTER	R&S	CMW 500	103818	2018-06-16	2019-06-15
8	DC Power Supply	Agilent	E3642A	N/A	2018-11-15	2019-11-14
9	EMI Test Software	AUDIX	E3	N/A	2018-06-16	2019-06-15
10	3m Semi Anechoic Chamber	SIDT FRANKONIA	SAC-3M	03CH03-HY	2018-06-16	2019-06-15
11	Positioning Controller	MF	MF-7082	N/A	2018-06-16	2019-06-15
12	Active Loop Antenna	SCHWARZBECK	FMZB 1519B	00005	2018-07-26	2019-07-25
13	By-log Antenna	SCHWARZBECK	VULB9163	9163-470	2018-07-26	2019-07-25
14	Horn Antenna	SCHWARZBECK	BBHA 9120D	9120D-1925	2018-07-02	2019-07-01
15	Broadband Horn Antenna	SCHWARZBECK	BBHA 9170	791	2018-09-20	2019-09-19
16	Broadband Preamplifier	SCHWARZBECK	BBV 9719	9719-025	2018-09-20	2019-09-19
17	EMI Test Receiver	R&S	ESR 7	101181	2018-06-16	2019-06-15
18	RS SPECTRUM ANALYZER	R&S	FSP40	100503	2018-11-15	2019-11-14
19	AMPLIFIER	QuieTek	QTK	CHM/0809065	2018-11-15	2019-11-14
20	RF Cable-R03m	Jye Bao	RG142	CB021	2018-06-16	2019-06-15
21	RF Cable-HIGH	SUHNER	SUCOFLEX 106	03CH03-HY	2018-06-16	2019-06-15
22	6dB Attenuator	/	100W/6dB	1172040	2018-06-16	2019-06-15
23	3dB Attenuator	/	2N-3dB	/	2018-06-16	2019-06-15
24	Temperature & Humidity Chamber	GUANGZHOU GOGNWEN	GDS-100	70932	2018-10-10	2019-10-09

Note: All equipment is calibrated through GUANGZHOU LISAI CALIBRATION AND TEST CO.,LTD.

3.6 Measurement uncertainty

The data and results referenced in this document are true and accurate. The reader is cautioned that there may be errors within the calibration limits of the equipment and facilities. The measurement uncertainty was calculated for all measurements listed in this test report acc. to ETSI TR 100 028 "Electromagnetic compatibility and Radio spectrum Matters (ERM); Uncertainties in the measurement of mobile radio equipment characteristics" and is documented in the Shenzhen LCS Compliance Testing Laboratory Ltd. quality system acc. to DIN EN ISO/IEC 17025. Furthermore, component and process variability of devices similar to that tested may result in additional deviation. The manufacturer has the sole responsibility of continued compliance of the device.

Hereafter the best measurement capability for Shenzhen LCS Compliance Testing Laboratory Ltd. is reported:

Test	Range	Measurement Uncertainty	Notes
Radiated Emission	30~1000MHz	3.10 dB	(1)
Radiated Emission	1~18GHz	3.80 dB	(1)
Radiated Emission	18-40GHz	3.90 dB	(1)
Conducted Disturbance	0.15~30MHz	1.63 dB	(1)
Conducted Power	9KHz~18GHz	0.61 dB	(1)
Spurious RF Conducted Emission	9KHz~40GHz	1.22 dB	(1)
Band Edge Compliance of RF Emission	9KHz~40GHz	1.22 dB	(1)
Occupied Bandwidth	9KHz~40GHz	-	(1)

(1) This uncertainty represents an expanded uncertainty expressed at approximately the 95% confidence level using a coverage factor of $k=1.96$.

4 TEST CONDITIONS AND RESULTS

4.1 Output Power

TEST APPLICABLE

During the process of testing, the EUT was controlled via R&S Digital Radio Communication tester (CMW500) to ensure max power transmission and proper modulation. This result contains output power and EIRP measurements for the EUT. In all cases, output power is within the specified limits.

4.1.1. Conducted Output Power

TEST CONFIGURATION

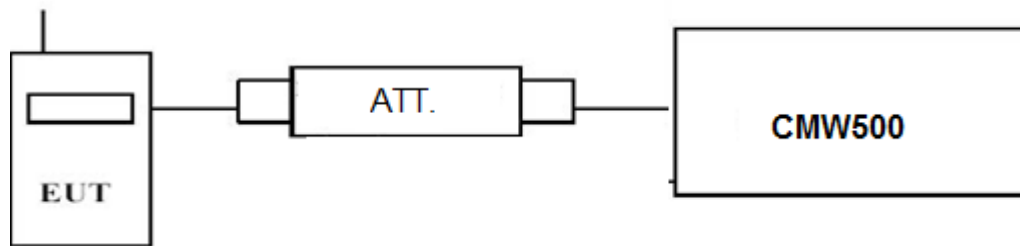

TEST PROCEDURE

Conducted Power Measurement:

- a) Place the EUT on a bench and set it in transmitting mode.
- b) Connect a low loss RF cable from the antenna port to a CMW500 by an Att.
- c) EUT Communicate with CMW500 then selects a channel for testing.
- d) Add a correction factor to the display CMW500, and then test.

TEST RESULTS

Remark:

1. We were tested all RB Configuration refer 3GPP TS136 521 for each Channel Bandwidth of LTE TDD Band 41;
2. For E-UTRA Band 41, please refer to Appendix A: Section A.1.

4.1.2. Radiated Output Power

LIMIT

This is the test for the maximum radiated power from the EUT.

Per Part 27.50(h) (2) specifies, The following power limits shall apply in the BRS and EBS: *Mobile and other user stations*. Mobile stations are limited to 2.0 watts EIRP. All user stations are limited to 2.0 watts transmitter output power.

TEST CONFIGURATION

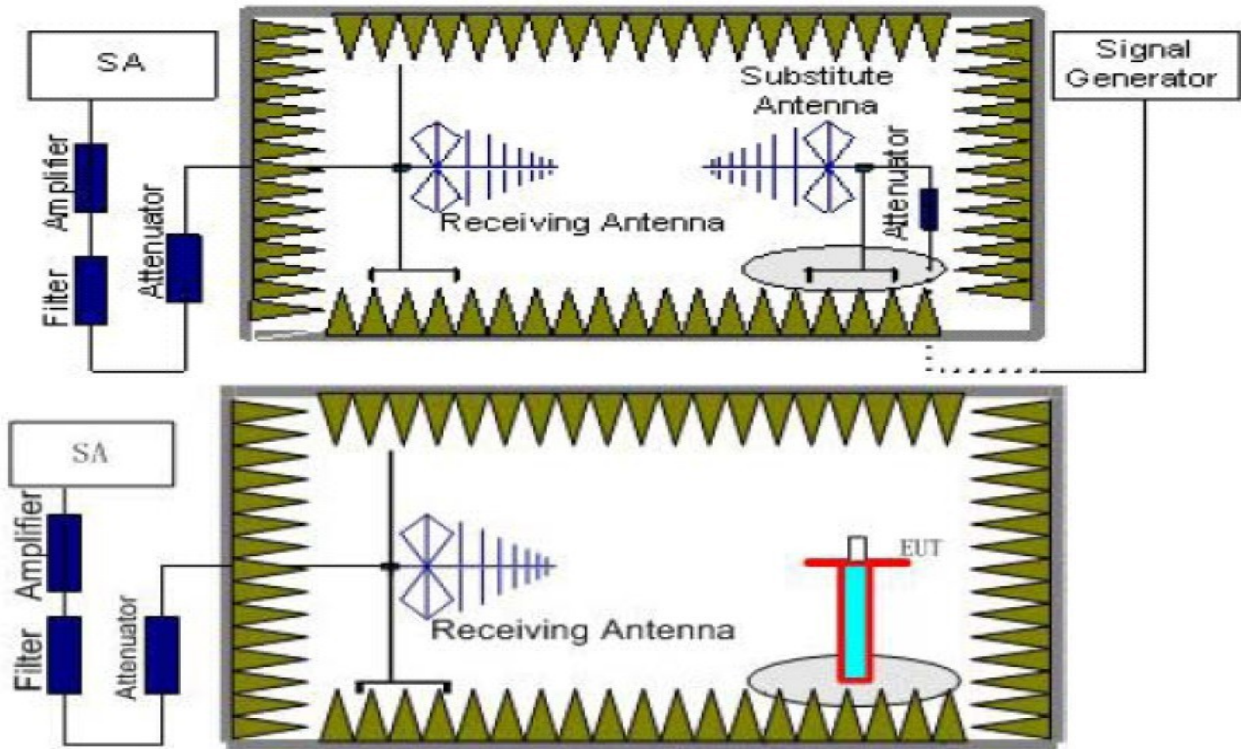

TEST PROCEDURE

1. EUT was placed on a 1.50 meter high non-conductive stand at a 3 meter test distance from the receive antenna. A receiving antenna was placed on the antenna mast 3 meters from the EUT for emission measurements. The height of receiving antenna is 1.50m. Detected emissions were maximized at each frequency by rotating the EUT through 360° and adjusting the receiving antenna polarization. The radiated emission measurements of all transmit frequencies in three channels (High, Middle, Low) were measured with peak detector.
2. A log-periodic antenna or double-ridged waveguide horn antenna shall be substituted in place of the EUT. The log-periodic antenna will be driven by a signal generator and the level will be adjusted till the same power value on the spectrum analyzer or receiver. The level of the spurious emissions can be calculated through the level of the signal generator, cable loss, the gain of the substitution antenna and the reading of the spectrum analyzer or receiver.
3. The EUT is then put into continuously transmitting mode at its maximum power level during the test. Set Test Receiver or Spectrum RBW=1MHz, VBW=3MHz, And the maximum value of the receiver should be recorded as (P_r).
4. The EUT shall be replaced by a substitution antenna. In the chamber, an substitution antenna for the frequency band of interest is placed at the reference point of the chamber. An RF Signal source for the frequency band of interest is connected to the substitution antenna with a cable that has been constructed to not interfere with the radiation pattern of the antenna. A power (P_{Mea}) is applied to the input of the substitution antenna, and adjust the level of the signal generator output until the value of the receiver reach the previously recorded (P_r). The power of signal source (P_{Mea}) is recorded. The test should be performed by rotating the test item and adjusting the receiving antenna polarization.

5. A amplifier should be connected to the Signal Source output port. And the cable should be connect between the Amplifier and the Substitution Antenna. The cable loss (P_{cl}), the Substitution Antenna Gain (G_a) and the Amplifier Gain (P_{Ag}) should be recorded after test.
The measurement results are obtained as described below:
 $Power(EIRP)=P_{Mea}- P_{Ag} - P_{cl} + G_a$
6. This value is EIRP since the measurement is calibrated using an antenna of known gain (2.15 dBi) and known input power.
7. ERP can be calculated from EIRP by subtracting the gain of the dipole, $ERP = EIRP-2.15dBi$.

TEST RESULTS

Radiated Measurement:

Remark:

1. We were tested all RB Configuration refer 3GPP TS136 521 for each Channel Bandwidth of LTE TDD Band 41; recorded worst case for each Channel Bandwidth of LTE TDD Band 41.
2. $EIRP=P_{Mea}(dBm)-P_{cl}(dB)+P_{Ag}(dB)+G_a(dBi)$
3. $ERP = EIRP - 2.15dBi$ as EIRP by subtracting the gain of the dipole.
4. Margin = Emission Level - Limit
5. We test the H direction and V direction recorded worst case

LTE TDD Band 41_Channel Bandwidth 5MHz_QPSK

Frequency (MHz)	P_{Mea} (dBm)	P_{cl} (dB)	G_a Antenna Gain(dB)	P_{Ag} (dB)	Burst Average EIRP (dBm)	Limit (dBm)	Margin (dB)	Polarization
2498.5	-18.30	4.52	8.62	36.32	22.12	33.01	-10.89	V
2593.0	-19.87	4.61	9.03	36.11	20.66	33.01	-12.35	V
2687.5	-18.53	4.78	8.95	36.07	21.71	33.01	-11.30	V

LTE TDD Band 41_Channel Bandwidth 10MHz_QPSK

Frequency (MHz)	P_{Mea} (dBm)	P_{cl} (dB)	G_a Antenna Gain(dB)	P_{Ag} (dB)	Burst Average EIRP (dBm)	Limit (dBm)	Margin (dB)	Polarization
2501.0	-19.90	4.52	8.62	36.32	20.52	33.01	-12.49	V
2593.0	-18.02	4.61	9.03	36.11	22.51	33.01	-10.50	V
2685.0	-18.88	4.78	8.95	36.07	21.36	33.01	-11.65	V

LTE TDD Band 41_Channel Bandwidth 15MHz_QPSK

Frequency (MHz)	P_{Mea} (dBm)	P_{cl} (dB)	G_a Antenna Gain(dB)	P_{Ag} (dB)	Burst Average EIRP (dBm)	Limit (dBm)	Margin (dB)	Polarization
2503.5	-18.37	4.52	8.62	36.32	22.05	33.01	-10.96	V
2593.0	-19.49	4.61	9.03	36.11	21.04	33.01	-11.97	V
2682.5	-18.81	4.78	8.95	36.07	21.43	33.01	-11.58	V

LTE TDD Band 41_Channel Bandwidth 20MHz_QPSK

Frequency (MHz)	P_{Mea} (dBm)	P_{cl} (dB)	G_a Antenna Gain(dB)	P_{Ag} (dB)	Burst Average EIRP (dBm)	Limit (dBm)	Margin (dB)	Polarization
2506.0	-18.41	4.52	8.62	36.32	22.01	33.01	-11.00	V
2593.0	-18.43	4.61	9.03	36.11	22.10	33.01	-10.91	V
2680.0	-18.25	4.78	8.95	36.07	21.99	33.01	-11.02	V

LTE TDD Band 41_Channel Bandwidth 5MHz_16QAM

Frequency (MHz)	P _{Mea} (dBm)	P _{cl} (dB)	G _a Antenna Gain(dB)	P _{Ag} (dB)	Burst Average EIRP (dBm)	Limit (dBm)	Margin (dB)	Polarization
2498.5	-20.78	4.52	8.62	36.32	19.64	33.01	-13.37	V
2593.0	-20.70	4.61	9.03	36.11	19.83	33.01	-13.18	V
2687.5	-20.06	4.78	8.95	36.07	20.18	33.01	-12.83	V

LTE TDD Band 41_Channel Bandwidth 10MHz_16QAM

Frequency (MHz)	P _{Mea} (dBm)	P _{cl} (dB)	G _a Antenna Gain(dB)	P _{Ag} (dB)	Burst Average EIRP (dBm)	Limit (dBm)	Margin (dB)	Polarization
2501.0	-20.76	4.52	8.62	36.32	19.66	33.01	-13.35	V
2593.0	-20.95	4.61	9.03	36.11	19.58	33.01	-13.43	V
2685.0	-19.33	4.78	8.95	36.07	20.91	33.01	-12.10	V

LTE TDD Band 41_Channel Bandwidth 15MHz_16QAM

Frequency (MHz)	P _{Mea} (dBm)	P _{cl} (dB)	G _a Antenna Gain(dB)	P _{Ag} (dB)	Burst Average EIRP (dBm)	Limit (dBm)	Margin (dB)	Polarization
2503.5	-20.20	4.52	8.62	36.32	20.22	33.01	-12.79	V
2593.0	-20.24	4.61	9.03	36.11	20.29	33.01	-12.72	V
2682.5	-20.69	4.78	8.95	36.07	19.55	33.01	-13.46	V

LTE TDD Band 41_Channel Bandwidth 20MHz_16QAM

Frequency (MHz)	P _{Mea} (dBm)	P _{cl} (dB)	G _a Antenna Gain(dB)	P _{Ag} (dB)	Burst Average EIRP (dBm)	Limit (dBm)	Margin (dB)	Polarization
2506.0	-19.10	4.52	8.62	36.32	21.32	33.01	-11.69	V
2593.0	-20.17	4.61	9.03	36.11	20.36	33.01	-12.65	V
2680.0	-20.29	4.78	8.95	36.07	19.95	33.01	-13.06	V

4.2 Peak-to-Average Ratio (PAR)

LIMIT

The Peak-to-Average Ratio (PAR) of the transmission may not exceed 13 dB.

TEST CONFIGURATION

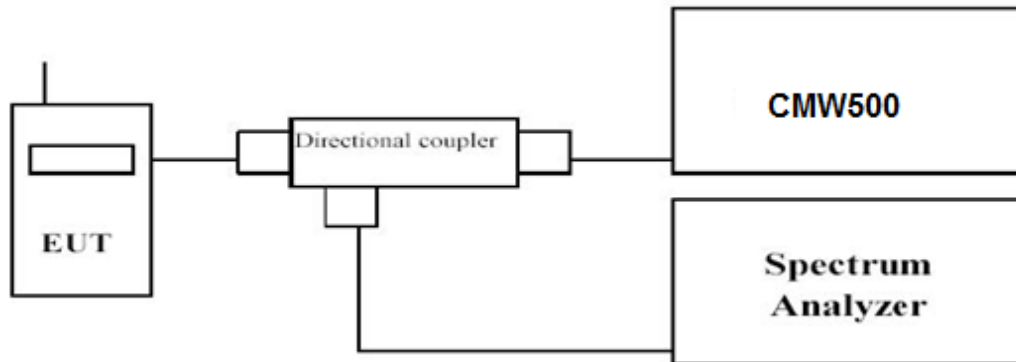

TEST PROCEDURE

1. Refer to instrument's analyzer instruction manual for details on how to use the power statistics/CCDF function;
2. Set resolution/measurement bandwidth \geq signal's occupied bandwidth;
3. Set the number of counts to a value that stabilizes the measured CCDF curve;
4. Set the measurement interval as follows:
 - 1). for continuous transmissions, set to 1 ms,
 - 2). for burst transmissions, employ an external trigger that is synchronized with the EUT burst timing sequence, or use the internal burst trigger with a trigger level that allows the burst to stabilize and set the measurement interval to a time that is less than or equal to the burst duration.
5. Record the maximum PAPR level associated with a probability of 0.1%.

TEST RESULTS

Remark:

1. We were tested all RB Configuration refer 3GPP TS136 521 for each Channel Bandwidth of LTE TDD Band 41;
2. For E-UTRA Band 41, please refer to Appendix A: Section A.2.

4.3 Occupied Bandwidth and Emission Bandwidth

LIMIT

N/A

TEST CONFIGURATION

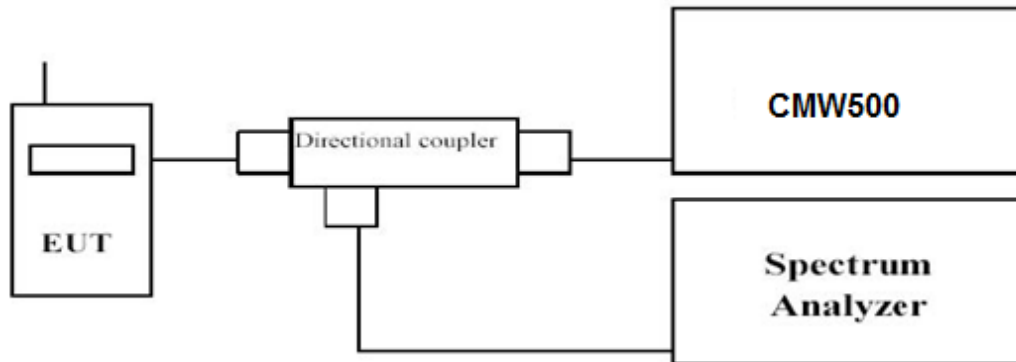

TEST PROCEDURE

The transmitter output was connected to a calibrated coaxial cable and coupler, the other end of which was connected to a spectrum analyzer. The occupied bandwidth was measured with the spectrum analyzer at low, middle and high channel in each band. The -26dBc Emission bandwidth was also measured and recorded. Set RBW was set to about 1% of emission BW, VBW \geq 3 times RBW.

-26dBc display line was placed on the screen (or 99% bandwidth), the occupied bandwidth is the delta frequency between the two points where the display line intersects the signal trace.

TEST RESULTS

Remark:

1. We were tested all RB Configuration refer 3GPP TS136 521 for each Channel Bandwidth of LTE TDD Band 41;
2. For E-UTRA Band 41, please refer to Appendix A: Section A.3.

4.4 Band Edge compliance

LIMIT

For LTE TDD Band 41: Per §27.53 (m)(6) Measurement procedure. Compliance with these rules is based on the use of measurement instrumentation employing a resolution bandwidth of 1 megahertz or greater. However, in the 1 MHz bands immediately outside and adjacent to the frequency block a resolution bandwidth of at least one percent of the emission bandwidth of the fundamental emission of the transmitter may be employed; for mobile digital stations, in the 1 megahertz bands immediately outside and adjacent to the frequency block a resolution bandwidth of at least two percent may be employed, except when the 1 megahertz band is 2495-2496 MHz, in which case a resolution bandwidth of at least one percent may be employed. A narrower resolution bandwidth is permitted in all cases to improve measurement accuracy provided the measured power is integrated over the full required measurement bandwidth (i.e. 1 megahertz or 1 percent of emission bandwidth, as specified; or 1 megahertz or 2 percent for mobile digital stations, except in the band 2495-2496 MHz). The emission bandwidth is defined as the width of the signal between two points, one below the carrier center frequency and one above the carrier center frequency, outside of which all emissions are attenuated at least 26 dB below the transmitter power. With respect to television operations, measurements must be made of the separate visual and aural operating powers at sufficiently frequent intervals to ensure compliance with the rules.

(m)(4) For mobile digital stations, the attenuation factor shall be not less than $40 + 10 \log (P)$ dB on all frequencies between the channel edge and 5 megahertz from the channel edge, $43 + 10 \log (P)$ dB on all frequencies between 5 megahertz and X megahertz from the channel edge, and $55 + 10 \log (P)$ dB on all frequencies more than X megahertz from the channel edge, where X is the greater of 6 megahertz or the actual emission bandwidth as defined in paragraph (m)(6) of this section. In addition, the attenuation factor shall not be less than $43 + 10 \log (P)$ dB on all frequencies between 2490.5 MHz and 2496 MHz and $55 + 10 \log (P)$ dB at or below 2490.5 MHz. Mobile Satellite Service licensees operating on frequencies below 2495 MHz may also submit a documented interference complaint against BRS licensees operating on channel BRS Channel 1 on the same terms and conditions as adjacent channel BRS or EBS licensees. Show citation box.

TEST CONFIGURATION

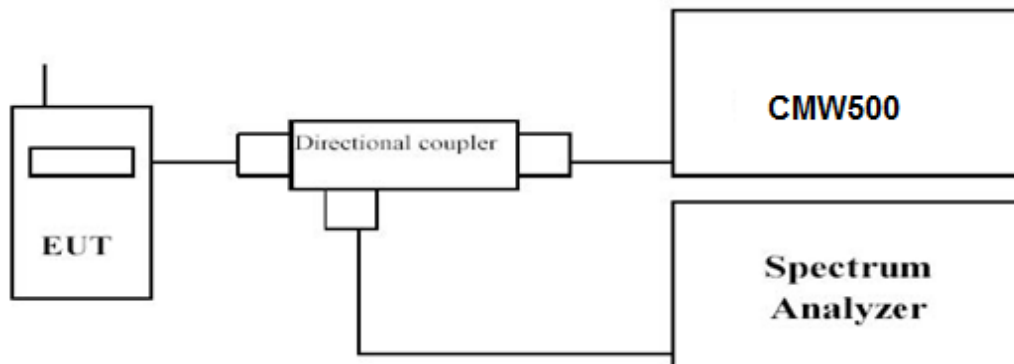

TEST PROCEDURE

1. The transmitter output port was connected to base station.
2. The RF output of EUT was connected to the power meter by RF cable and attenuator, the path loss was compensated to the results for each measurement.
3. Set EUT at maximum power through base station.
4. Select lowest and highest channels for each band and different modulation.
5. Measure Band edge using RMS (Average) detector by spectrum

TEST RESULTS

Remark:

1. We were tested all RB Configuration refer 3GPP TS136 521 for each Channel Bandwidth of LTE TDD Band 41;
2. For E-UTRA Band 41, please refer to Appendix A: Section A.4.

4.5 Spurious Emission on Antenna Port

LIMIT

For LTE TDD Band 41: Per §27.53 (m)(6) Measurement procedure. Compliance with these rules is based on the use of measurement instrumentation employing a resolution bandwidth of 1 megahertz or greater. However, in the 1 MHz bands immediately outside and adjacent to the frequency block a resolution bandwidth of at least one percent of the emission bandwidth of the fundamental emission of the transmitter may be employed; for mobile digital stations, in the 1 megahertz bands immediately outside and adjacent to the frequency block a resolution bandwidth of at least two percent may be employed, except when the 1 megahertz band is 2495-2496 MHz, in which case a resolution bandwidth of at least one percent may be employed. A narrower resolution bandwidth is permitted in all cases to improve measurement accuracy provided the measured power is integrated over the full required measurement bandwidth (i.e. 1 megahertz or 1 percent of emission bandwidth, as specified; or 1 megahertz or 2 percent for mobile digital stations, except in the band 2495-2496 MHz). The emission bandwidth is defined as the width of the signal between two points, one below the carrier center frequency and one above the carrier center frequency, outside of which all emissions are attenuated at least 26 dB below the transmitter power. With respect to television operations, measurements must be made of the separate visual and aural operating powers at sufficiently frequent intervals to ensure compliance with the rules.

(m)(4) For mobile digital stations, the attenuation factor shall be not less than $40 + 10 \log (P)$ dB on all frequencies between the channel edge and 5 megahertz from the channel edge, $43 + 10 \log (P)$ dB on all frequencies between 5 megahertz and X megahertz from the channel edge, and $55 + 10 \log (P)$ dB on all frequencies more than X megahertz from the channel edge, where X is the greater of 6 megahertz or the actual emission bandwidth as defined in paragraph (m)(6) of this section. In addition, the attenuation factor shall not be less than $43 + 10 \log (P)$ dB on all frequencies between 2490.5 MHz and 2496 MHz and $55 + 10 \log (P)$ dB at or below 2490.5 MHz. Mobile Satellite Service licensees operating on frequencies below 2495 MHz may also submit a documented interference complaint against BRS licensees operating on channel BRS Channel 1 on the same terms and conditions as adjacent channel BRS or EBS licensees. Show citation box.

TEST CONFIGURATION

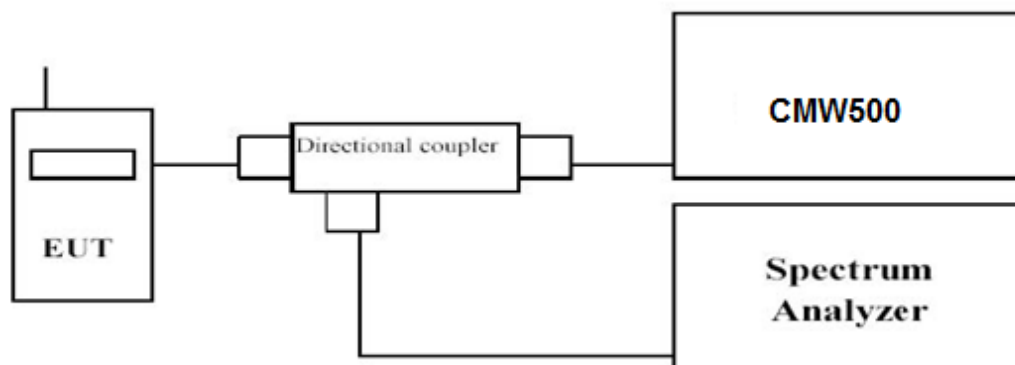

TEST PROCEDURE

The EUT was setup according to EIA/TIA 603D

- Place the EUT on a bench and set it in transmitting mode.
- Connect a low loss RF cable from the antenna port to a spectrum analyzer and CMW500 by a Directional Couple.
- EUT Communicate with CMW500, then select a channel for testing.
- Add a correction factor to the display of spectrum, and then test.
- The resolution bandwidth of the spectrum analyzer was set sufficient scans were taken to show the out of band Emission if any up to 10th harmonic.
- Please refer to following tables for test antenna conducted emissions.

Working Frequency	Sub range (GHz)	RBW	VBW	Sweep time (s)
LTE TDD Band 41	0.000009~0.000015	1KHz	3KHz	Auto
	0.000015~0.03	10KHz	30KHz	Auto
	0.03~26	1 MHz	3 MHz	Auto

TEST RESULTS

Remark:

1. We were tested all RB Configuration refer 3GPP TS136 521 for each Channel Bandwidth of LTE TDD Band 41;
2. For E-UTRA Band 41, please refer to Appendix A: Section A.5.

4.6 Radiated Spurious Emission

LIMIT

For LTE TDD Band 41: Per §27.53 (m)(6) Measurement procedure. Compliance with these rules is based on the use of measurement instrumentation employing a resolution bandwidth of 1 megahertz or greater. However, in the 1 MHz bands immediately outside and adjacent to the frequency block a resolution bandwidth of at least one percent of the emission bandwidth of the fundamental emission of the transmitter may be employed; for mobile digital stations, in the 1 megahertz bands immediately outside and adjacent to the frequency block a resolution bandwidth of at least two percent may be employed, except when the 1 megahertz band is 2495-2496 MHz, in which case a resolution bandwidth of at least one percent may be employed. A narrower resolution bandwidth is permitted in all cases to improve measurement accuracy provided the measured power is integrated over the full required measurement bandwidth (i.e. 1 megahertz or 1 percent of emission bandwidth, as specified; or 1 megahertz or 2 percent for mobile digital stations, except in the band 2495-2496 MHz). The emission bandwidth is defined as the width of the signal between two points, one below the carrier center frequency and one above the carrier center frequency, outside of which all emissions are attenuated at least 26 dB below the transmitter power. With respect to television operations, measurements must be made of the separate visual and aural operating powers at sufficiently frequent intervals to ensure compliance with the rules.

(m)(4) For mobile digital stations, the attenuation factor shall be not less than $40 + 10 \log (P)$ dB on all frequencies between the channel edge and 5 megahertz from the channel edge, $43 + 10 \log (P)$ dB on all frequencies between 5 megahertz and X megahertz from the channel edge, and $55 + 10 \log (P)$ dB on all frequencies more than X megahertz from the channel edge, where X is the greater of 6 megahertz or the actual emission bandwidth as defined in paragraph (m)(6) of this section. In addition, the attenuation factor shall not be less than $43 + 10 \log (P)$ dB on all frequencies between 2490.5 MHz and 2496 MHz and $55 + 10 \log (P)$ dB at or below 2490.5 MHz. Mobile Satellite Service licensees operating on frequencies below 2495 MHz may also submit a documented interference complaint against BRS licensees operating on channel BRS Channel 1 on the same terms and conditions as adjacent channel BRS or EBS licensees. Show citation box.

TEST CONFIGURATION

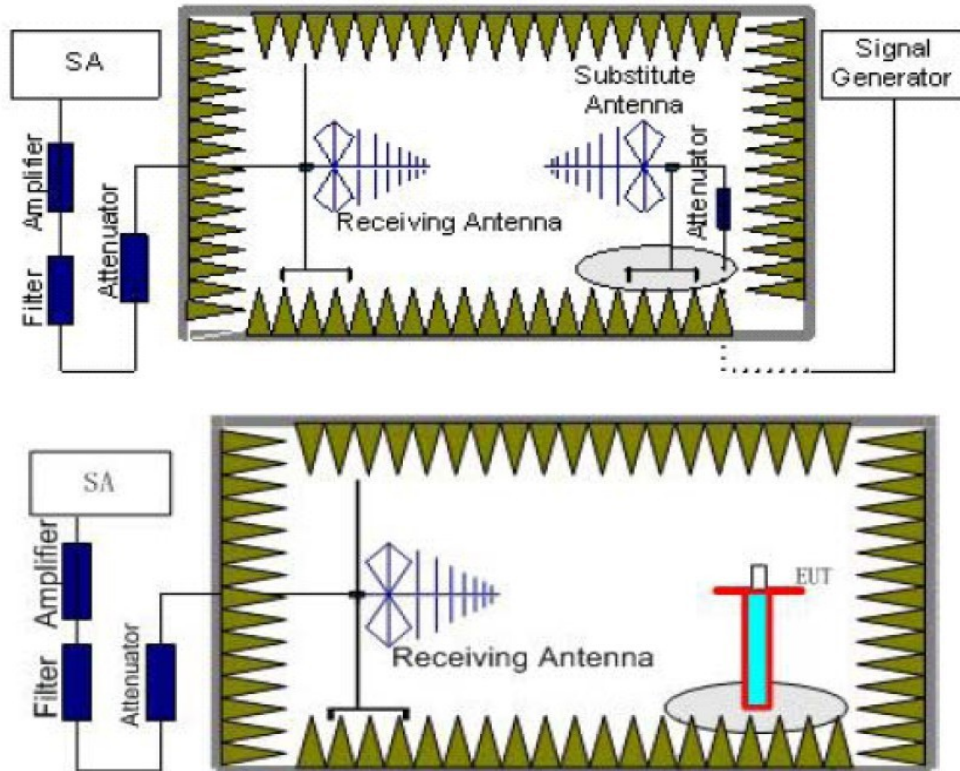

TEST PROCEDURE

1. EUT was placed on a 1.50 meter high non-conductive stand at a 3 meter test distance from the receive antenna. A receiving antenna was placed on the antenna mast 3 meters from the EUT for emission

measurements. The height of receiving antenna is 1.50m. Detected emissions were maximized at each frequency by rotating the EUT through 360° and adjusting the receiving antenna polarization. The radiated emission measurements of all transmit frequencies in three channels (High, Middle, Low) were measured with peak detector.

2. A log-periodic antenna or double-ridged waveguide horn antenna shall be substituted in place of the EUT. The log-periodic antenna will be driven by a signal generator and the level will be adjusted till the same power value on the spectrum analyzer or receiver. The level of the spurious emissions can be calculated through the level of the signal generator, cable loss, the gain of the substitution antenna and the reading of the spectrum analyzer or receiver.
3. The EUT is then put into continuously transmitting mode at its maximum power level during the test. Set Test Receiver or Spectrum RBW=1MHz, VBW=3MHz, And the maximum value of the receiver should be recorded as (P_r).
4. The EUT shall be replaced by a substitution antenna. In the chamber, a substitution antenna for the frequency band of interest is placed at the reference point of the chamber. An RF Signal source for the frequency band of interest is connected to the substitution antenna with a cable that has been constructed to not interfere with the radiation pattern of the antenna. A power (P_{Mea}) is applied to the input of the substitution antenna, and adjust the level of the signal generator output until the value of the receiver reach the previously recorded (P_r). The power of signal source (P_{Mea}) is recorded. The test should be performed by rotating the test item and adjusting the receiving antenna polarization.
5. A amplifier should be connected to the Signal Source output port. And the cable should be connect between the Amplifier and the Substitution Antenna. The cable loss (P_{cl}), the Substitution Antenna Gain (G_a) and the Amplifier Gain (P_{Ag}) should be recorded after test.
The measurement results are obtained as described below:
Power(EIRP)= $P_{Mea} - P_{Ag} - P_{cl} + G_a$
6. This value is EIRP since the measurement is calibrated using an antenna of known gain (2.15 dBi) and known input power.
7. ERP can be calculated from EIRP by subtracting the gain of the dipole, ERP = EIRP -2.15dBi.
8. In order to make sure test results more clearly, we set frequency range and sweep time for difference frequency range as follows table:

Working Frequency	Subrange (GHz)	RBW	VBW	Sweep time (s)
LTE TDD Band 41	0.00009~0.15	1KHz	3KHz	30
	0.00015~0.03	10KHz	30KHz	10
	0.03~1	100KHz	300KHz	10
	1~2	1 MHz	3 MHz	2
	2~5	1 MHz	3 MHz	3
	5~8	1 MHz	3 MHz	3
	8~11	1 MHz	3 MHz	3
	11~14	1 MHz	3 MHz	3
	14~18	1 MHz	3 MHz	3
	18~20	1 MHz	3 MHz	2
20~26	1 MHz	3 MHz	2	

TEST LIMITS

According to 27.53(h) specify that the power of any emission outside of the authorized operating frequency ranges must be attenuated below the transmitting power (P) by a factor of at least $43 + 10 \log(P)$ dB.

The specification that emissions shall be attenuated below the transmitter power (P) by at least $43 + 10 \log(P)$ dB, translates in the relevant power range (1 to 0.001 W) to -13 dBm. At 1 W the specified minimum attenuation becomes 43 dB and relative to a 30 dBm (1 W) carrier becomes a limit of -13 dBm. At 0.001 W (0 dBm) the minimum attenuation is 13 dB, which again yields a limit of -13 dBm. In this way a translation of the specification from relative to absolute terms is carried out.

Frequency	Channel	Frequency Range	Verdict
LTE TDD Band 41	Low	9KHz -26GHz	PASS
	Middle	9KHz -26GHz	PASS
	High	9KHz -26GHz	PASS

TEST RESULTS

Remark:

1. We were tested all RB Configuration refer 3GPP TS136 521 for each Channel Bandwidth of LTE TDD Band 41;
2. $EIRP = P_{Mea}(dBm) - P_{cl}(dB) + G_a(dBi)$;
3. We were not recorded other points as values lower than limits;
4. $Margin = EIRP - Limit$.

LTE TDD Band 41_Channel Bandwidth 5MHz_QPSK_Low Channel

Frequency (MHz)	P _{Mea} (dBm)	P _{cl} (dB)	Diatance	G _a Antenna Gain(dB)	Peak EIRP (dBm)	Limit (dBm)	Margin (dB)	Polarization
4997.0	-41.06	7.15	3.00	9.88	-38.33	-25.00	-13.33	H
7495.5	-53.44	8.36	3.00	11.36	-50.44	-25.00	-25.44	H
4997.0	-45.51	7.15	3.00	9.88	-42.78	-25.00	-17.78	V
7495.5	-48.47	8.36	3.00	11.36	-45.47	-25.00	-20.47	V

LTE TDD Band 41_Channel Bandwidth 5MHz_QPSK_Middle Channel

Frequency (MHz)	P _{Mea} (dBm)	P _{cl} (dB)	Diatance	G _a Antenna Gain(dB)	Peak EIRP (dBm)	Limit (dBm)	Margin (dB)	Polarization
5186.0	-44.95	7.26	3.00	10.03	-42.18	-25.00	-17.18	H
7779.0	-46.59	8.48	3.00	11.41	-43.66	-25.00	-18.66	H
5186.0	-40.24	7.26	3.00	10.03	-37.47	-25.00	-12.47	V
7779.0	-49.56	8.48	3.00	11.41	-46.63	-25.00	-21.63	V

LTE TDD Band 41_Channel Bandwidth 5MHz_QPSK_High Channel

Frequency (MHz)	P _{Mea} (dBm)	P _{cl} (dB)	Diatance	G _a Antenna Gain(dB)	Peak EIRP (dBm)	Limit (dBm)	Margin (dB)	Polarization
5375.0	-45.30	7.17	3.00	9.62	-42.85	-25.00	-17.85	H
8062.5	-46.30	8.39	3.00	11.46	-43.23	-25.00	-18.23	H
5375.0	-42.67	7.17	3.00	9.62	-40.22	-25.00	-15.22	V
8062.5	-47.36	8.39	3.00	11.46	-44.29	-25.00	-19.29	V

LTE TDD Band 41_Channel Bandwidth 10MHz_QPSK_Low Channel

Frequency (MHz)	P _{Mea} (dBm)	P _{cl} (dB)	Diatance	G _a Antenna Gain(dB)	Peak EIRP (dBm)	Limit (dBm)	Margin (dB)	Polarization
4982.0	-43.34	7.15	3.00	9.88	-40.61	-25.00	-15.61	H
7473.0	-54.33	8.36	3.00	11.36	-51.33	-25.00	-26.33	H
4982.0	-45.92	7.15	3.00	9.88	-43.19	-25.00	-18.19	V
7473.0	-48.03	8.36	3.00	11.36	-45.03	-25.00	-20.03	V

LTE TDD Band 41_Channel Bandwidth 10MHz_QPSK_Middle Channel

Frequency (MHz)	P _{Mea} (dBm)	P _{cl} (dB)	Diatance	G _a Antenna Gain(dB)	Peak EIRP (dBm)	Limit (dBm)	Margin (dB)	Polarization
5186.0	-41.32	7.26	3.00	10.03	-38.55	-25.00	-13.55	H
7779.0	-55.42	8.48	3.00	11.41	-52.49	-25.00	-27.49	H
5186.0	-44.14	7.26	3.00	10.03	-41.37	-25.00	-16.37	V
7779.0	-48.76	8.48	3.00	11.41	-45.83	-25.00	-20.83	V

LTE TDD Band 41_Channel Bandwidth 10MHz_QPSK_High Channel

Frequency (MHz)	P _{Mea} (dBm)	P _{cl} (dB)	Diatance	G _a Antenna Gain(dB)	Peak EIRP (dBm)	Limit (dBm)	Margin (dB)	Polarization
5370.0	-45.43	7.17	3.00	9.62	-42.98	-25.00	-17.98	H
8055.0	-49.74	8.39	3.00	11.46	-46.67	-25.00	-21.67	H
5370.0	-40.98	7.17	3.00	9.62	-38.53	-25.00	-13.53	V
8055.0	-54.44	8.39	3.00	11.46	-51.37	-25.00	-26.37	V

LTE TDD Band 41_Channel Bandwidth 15MHz_QPSK_Low Channel

Frequency (MHz)	P _{Mea} (dBm)	P _{cl} (dB)	Diatance	G _a Antenna Gain(dB)	Peak EIRP (dBm)	Limit (dBm)	Margin (dB)	Polarization
5007.0	-43.60	7.15	3.00	9.88	-40.87	-25.00	-15.87	H
7510.5	-52.74	8.36	3.00	11.36	-49.74	-25.00	-24.74	H
5007.0	-42.05	7.15	3.00	9.88	-39.32	-25.00	-14.32	V
7510.5	-55.41	8.36	3.00	11.36	-52.41	-25.00	-27.41	V

LTE TDD Band 41_Channel Bandwidth 15MHz_QPSK_Middle Channel

Frequency (MHz)	P _{Mea} (dBm)	P _{cl} (dB)	Diatance	G _a Antenna Gain(dB)	Peak EIRP (dBm)	Limit (dBm)	Margin (dB)	Polarization
5186.0	-45.55	7.26	3.00	10.03	-42.78	-25.00	-17.78	H
7779.0	-46.81	8.48	3.00	11.41	-43.88	-25.00	-18.88	H
5186.0	-43.28	7.26	3.00	10.03	-40.51	-25.00	-15.51	V
7779.0	-47.28	8.48	3.00	11.41	-44.35	-25.00	-19.35	V

LTE TDD Band 41_Channel Bandwidth 15MHz_QPSK_High Channel

Frequency (MHz)	P _{Mea} (dBm)	P _{cl} (dB)	Diatance	G _a Antenna Gain(dB)	Peak EIRP (dBm)	Limit (dBm)	Margin (dB)	Polarization
5365.0	-44.65	7.17	3.00	9.62	-42.20	-25.00	-17.20	H
8047.0	-46.61	8.39	3.00	11.46	-43.54	-25.00	-18.54	H
5365.0	-45.44	7.17	3.00	9.62	-42.99	-25.00	-17.99	V
8047.0	-51.75	8.39	3.00	11.46	-48.68	-25.00	-23.68	V

LTE TDD Band 41_Channel Bandwidth 20MHz_QPSK_Low Channel

Frequency (MHz)	P _{Mea} (dBm)	P _{cl} (dB)	Diatance	G _a Antenna Gain(dB)	Peak EIRP (dBm)	Limit (dBm)	Margin (dB)	Polarization
5012.0	-43.64	7.15	3.00	9.88	-40.91	-25.00	-15.91	H
7518.0	-50.42	8.36	3.00	11.36	-47.42	-25.00	-22.42	H
5012.0	-44.14	7.15	3.00	9.88	-41.41	-25.00	-16.41	V
7518.0	-53.57	8.36	3.00	11.36	-50.57	-25.00	-25.57	V

LTE TDD Band 41_Channel Bandwidth 20MHz_QPSK_Middle Channel

Frequency (MHz)	P _{Mea} (dBm)	P _{cl} (dB)	Diatance	G _a Antenna Gain(dB)	Peak EIRP (dBm)	Limit (dBm)	Margin (dB)	Polarization
5186.0	-44.10	7.26	3.00	10.03	-41.33	-25.00	-16.33	H
7779.0	-48.42	8.48	3.00	11.41	-45.49	-25.00	-20.49	H
5186.0	-41.84	7.26	3.00	10.03	-39.07	-25.00	-14.07	V
7779.0	-49.64	8.48	3.00	11.41	-46.71	-25.00	-21.71	V

LTE TDD Band 41_Channel Bandwidth 20MHz_QPSK_High Channel

Frequency (MHz)	P _{Mea} (dBm)	P _{cl} (dB)	Diatance	G _a Antenna Gain(dB)	Peak EIRP (dBm)	Limit (dBm)	Margin (dB)	Polarization
5360.0	-44.66	7.17	3.00	9.62	-42.21	-25.00	-17.21	H
8040.0	-53.10	8.39	3.00	11.46	-50.03	-25.00	-25.03	H
5360.0	-42.05	7.17	3.00	9.62	-39.60	-25.00	-14.60	V
8040.0	-55.53	8.39	3.00	11.46	-52.46	-25.00	-27.46	V

LTE TDD Band 41_Channel Bandwidth 5MHz_16QAM_Low Channel

Frequency (MHz)	P _{Mea} (dBm)	P _{cl} (dB)	Diatance	G _a Antenna Gain(dB)	Peak EIRP (dBm)	Limit (dBm)	Margin (dB)	Polarization
4997.0	-44.49	7.15	3.00	9.88	-41.76	-25.00	-16.76	H
7495.5	-55.08	8.36	3.00	11.36	-52.08	-25.00	-27.08	H
4997.0	-43.88	7.15	3.00	9.88	-41.15	-25.00	-16.15	V
7495.5	-49.69	8.36	3.00	11.36	-46.69	-25.00	-21.69	V

LTE TDD Band 41_Channel Bandwidth 5MHz_16QAM_Middle Channel

Frequency (MHz)	P _{Mea} (dBm)	P _{cl} (dB)	Diatance	G _a Antenna Gain(dB)	Peak EIRP (dBm)	Limit (dBm)	Margin (dB)	Polarization
5186.0	-44.85	7.26	3.00	10.03	-42.08	-25.00	-17.08	H
7779.0	-46.98	8.48	3.00	11.41	-44.05	-25.00	-19.05	H
5186.0	-40.84	7.26	3.00	10.03	-38.07	-25.00	-13.07	V
7779.0	-49.91	8.48	3.00	11.41	-46.98	-25.00	-21.98	V

LTE TDD Band 41_Channel Bandwidth 5MHz_16QAM_High Channel

Frequency (MHz)	P _{Mea} (dBm)	P _{cl} (dB)	Diatance	G _a Antenna Gain(dB)	Peak EIRP (dBm)	Limit (dBm)	Margin (dB)	Polarization
5375.0	-40.83	7.17	3.00	9.62	-38.38	-25.00	-13.38	H
8062.5	-53.82	8.39	3.00	11.46	-50.75	-25.00	-25.75	H
5375.0	-43.57	7.17	3.00	9.62	-41.12	-25.00	-16.12	V
8062.5	-46.56	8.39	3.00	11.46	-43.49	-25.00	-18.49	V

LTE TDD Band 41_Channel Bandwidth 10MHz_16QAM_Low Channel

Frequency (MHz)	P _{Mea} (dBm)	P _{cl} (dB)	Diatance	G _a Antenna Gain(dB)	Peak EIRP (dBm)	Limit (dBm)	Margin (dB)	Polarization
4982.0	-43.69	7.15	3.00	9.88	-40.96	-25.00	-15.96	H
7473.0	-54.28	8.36	3.00	11.36	-51.28	-25.00	-26.28	H
4982.0	-43.08	7.15	3.00	9.88	-40.35	-25.00	-15.35	V
7473.0	-46.20	8.36	3.00	11.36	-43.2	-25.00	-18.20	V

LTE TDD Band 41_Channel Bandwidth 10MHz_16QAM_Middle Channel

Frequency (MHz)	P _{Mea} (dBm)	P _{cl} (dB)	Diatance	G _a Antenna Gain(dB)	Peak EIRP (dBm)	Limit (dBm)	Margin (dB)	Polarization
5186.0	-40.87	7.26	3.00	10.03	-38.1	-25.00	-13.10	H
7779.0	-50.97	8.48	3.00	11.41	-48.04	-25.00	-23.04	H
5186.0	-44.40	7.26	3.00	10.03	-41.63	-25.00	-16.63	V
7779.0	-49.46	8.48	3.00	11.41	-46.53	-25.00	-21.53	V

LTE TDD Band 41_Channel Bandwidth 10MHz_16QAM_High Channel

Frequency (MHz)	P _{Mea} (dBm)	P _{cl} (dB)	Diatance	G _a Antenna Gain(dB)	Peak EIRP (dBm)	Limit (dBm)	Margin (dB)	Polarization
5370.0	-42.55	7.17	3.00	9.62	-40.1	-25.00	-15.10	H
8055.0	-52.93	8.39	3.00	11.46	-49.86	-25.00	-24.86	H
5370.0	-41.75	7.17	3.00	9.62	-39.3	-25.00	-14.30	V
8055.0	-47.34	8.39	3.00	11.46	-44.27	-25.00	-19.27	V

LTE TDD Band 41_Channel Bandwidth 15MHz_16QAM_Low Channel

Frequency (MHz)	P _{Mea} (dBm)	P _{cl} (dB)	Diatance	G _a Antenna Gain(dB)	Peak EIRP (dBm)	Limit (dBm)	Margin (dB)	Polarization
5007.0	-40.83	7.15	3.00	9.88	-38.1	-25.00	-13.10	H
7510.5	-55.95	8.36	3.00	11.36	-52.95	-25.00	-27.95	H
5007.0	-42.19	7.15	3.00	9.88	-39.46	-25.00	-14.46	V
7510.5	-52.48	8.36	3.00	11.36	-49.48	-25.00	-24.48	V

LTE TDD Band 41_Channel Bandwidth 15MHz_16QAM_Middle Channel

Frequency (MHz)	P _{Mea} (dBm)	P _{cl} (dB)	Diatance	G _a Antenna Gain(dB)	Peak EIRP (dBm)	Limit (dBm)	Margin (dB)	Polarization
5186.0	-40.10	7.26	3.00	10.03	-37.33	-25.00	-12.33	H
7779.0	-53.35	8.48	3.00	11.41	-50.42	-25.00	-25.42	H
5186.0	-40.43	7.26	3.00	10.03	-37.66	-25.00	-12.66	V
7779.0	-51.21	8.48	3.00	11.41	-48.28	-25.00	-23.28	V

LTE TDD Band 41_Channel Bandwidth 15MHz_16QAM_High Channel

Frequency (MHz)	P _{Mea} (dBm)	P _{cl} (dB)	Diatance	G _a Antenna Gain(dB)	Peak EIRP (dBm)	Limit (dBm)	Margin (dB)	Polarization
5365.0	-44.42	7.17	3.00	9.62	-41.97	-25.00	-16.97	H
8047.0	-48.91	8.39	3.00	11.46	-45.84	-25.00	-20.84	H
5365.0	-42.95	7.17	3.00	9.62	-40.5	-25.00	-15.50	V
8047.0	-50.26	8.39	3.00	11.46	-47.19	-25.00	-22.19	V

LTE TDD Band 41_Channel Bandwidth 20MHz_16QAM_Low Channel

Frequency (MHz)	P _{Mea} (dBm)	P _{cl} (dB)	Diatance	G _a Antenna Gain(dB)	Peak EIRP (dBm)	Limit (dBm)	Margin (dB)	Polarization
5012.0	-45.30	7.15	3.00	9.88	-42.57	-25.00	-17.57	H
7518.0	-49.59	8.36	3.00	11.36	-46.59	-25.00	-21.59	H
5012.0	-42.76	7.15	3.00	9.88	-40.03	-25.00	-15.03	V
7518.0	-50.51	8.36	3.00	11.36	-47.51	-25.00	-22.51	V

LTE TDD Band 41_Channel Bandwidth 20MHz_16QAM_Middle Channel

Frequency (MHz)	P _{Mea} (dBm)	P _{cl} (dB)	Diatance	G _a Antenna Gain(dB)	Peak EIRP (dBm)	Limit (dBm)	Margin (dB)	Polarization
5186.0	-41.57	7.26	3.00	10.03	-38.80	-25.00	-13.80	H
7779.0	-55.41	8.48	3.00	11.41	-52.48	-25.00	-27.48	H
5186.0	-44.12	7.26	3.00	10.03	-41.35	-25.00	-16.35	V
7779.0	-46.59	8.48	3.00	11.41	-43.66	-25.00	-18.66	V

LTE TDD Band 41_Channel Bandwidth 20MHz_16QAM_High Channel

cui	P _{Mea} (dBm)	P _{cl} (dB)	Diatance	G _a Antenna Gain(dB)	Peak EIRP (dBm)	Limit (dBm)	Margin (dB)	Polarization
5360.0	-42.61	7.17	3.00	9.62	-40.16	-25.00	-15.16	H
8040.0	-52.79	8.39	3.00	11.46	-49.72	-25.00	-24.72	H
5360.0	-44.57	7.17	3.00	9.62	-42.12	-25.00	-17.12	V
8040.0	-49.43	8.39	3.00	11.46	-46.36	-25.00	-21.36	V

4.7 Frequency Stability under Temperature & Voltage Variations

LIMIT

According to §27.54, §2.1055 requirement, the frequency stability shall be sufficient to ensure that the fundamental emissions stay within the authorized bands of operation and should not exceed 2.5ppm.

TEST CONFIGURATION

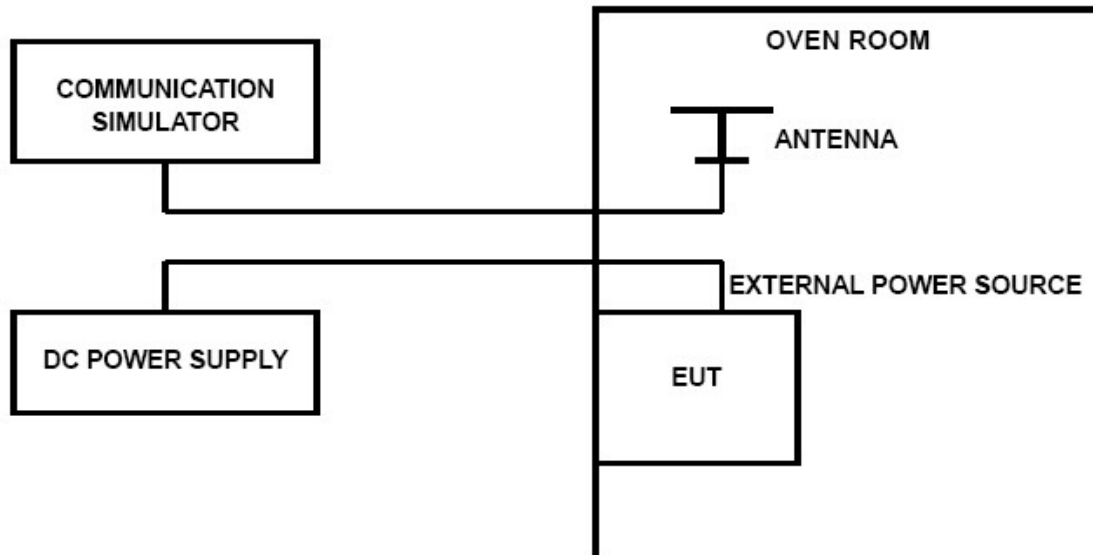

TEST PROCEDURE

The EUT was setup according to EIA/TIA 603D

Frequency Stability Under Temperature Variations:

In order to measure the carrier frequency under the condition of AFC lock, it is necessary to make measurements with the EUT in a "call mode". This is accomplished with the use of R&S CMW500 DIGITAL RADIO COMMUNICATION TESTER.

1. Measure the carrier frequency at room temperature.
2. Subject the EUT to overnight soak at -30°C.
3. With the EUT, powered via nominal voltage, connected to the CMW500 and in a simulated call on middle channel for LTE band 4, measure the carrier frequency. These measurements should be made within 2 minutes of Powering up the EUT, to prevent significant self-warming.
4. Repeat the above measurements at 10°C increments from -30°C to +50°C. Allow at least 1.5 hours at each temperature, unpowered, before making measurements.
5. Re-measure carrier frequency at room temperature with nominal voltage. Vary supply voltage from minimum voltage to maximum voltage, in 0.1Volt increments re-measuring carrier frequency at each voltage. Pause at nominal voltage for 1.5 hours unpowered, to allow any self-heating to stabilize, before continuing.
6. Subject the EUT to overnight soak at +50°C.
7. With the EUT, powered via nominal voltage, connected to the CMW500 and in a simulated call on the centre channel, measure the carrier frequency. These measurements should be made within 2 minutes of Powering up the EUT, to prevent significant self-warming.
8. Repeat the above measurements at 10 °C increments from +50°C to -30°C. Allow at least 1.5 hours at each temperature, unpowered, before making measurements
9. At all temperature levels hold the temperature to +/- 0.5°C during the measurement procedure.

Frequency Stability Under Voltage Variations:

Set chamber temperature to 20°C. Use a variable AC power supply / DC power source to power the EUT and set the voltage to rated voltage. Set the spectrum analyzer RBW low enough to obtain the desired frequency resolution and recorded the frequency.

Reduce the input voltage to specify extreme voltage variation ($\pm 15\%$) and endpoint, record the maximum frequency change.

TEST RESULTS

Remark:

1. We were tested all RB Configuration refer 3GPP TS136 521 for each Channel Bandwidth of LTE TDD Band 41.

LTE Band 41, 5MHz bandwidth, QPSK (worst case of all bandwidths)

LTE TDD Band 41					
DC Power	Temperature (°C)	Frequency error(Hz)	Frequency error(ppm)	Limit (ppm)	Verdict
6.66	20	39	0.019	2.50	PASS
7.40	20	69	0.033	2.50	PASS
8.14	20	85	0.041	2.50	PASS
7.40	-30	2	0.001	2.50	PASS
7.40	-20	0	0.000	2.50	PASS
7.40	-10	20	0.010	2.50	PASS
7.40	0	59	0.028	2.50	PASS
7.40	10	87	0.042	2.50	PASS
7.40	20	2	0.001	2.50	PASS
7.40	30	12	0.006	2.50	PASS
7.40	40	17	0.008	2.50	PASS
7.40	50	60	0.029	2.50	PASS

LTE Band 41, 5MHz bandwidth, 16QAM (worst case of all bandwidths)

LTE TDD Band 41					
DC Power	Temperature (°C)	Frequency error(Hz)	Frequency error(ppm)	Limit (ppm)	Verdict
6.66	20	68	0.032	2.50	PASS
7.40	20	33	0.016	2.50	PASS
8.14	20	34	0.016	2.50	PASS
7.40	-30	65	0.031	2.50	PASS
7.40	-20	16	0.008	2.50	PASS
7.40	-10	22	0.011	2.50	PASS
7.40	0	70	0.033	2.50	PASS
7.40	10	83	0.040	2.50	PASS
7.40	20	32	0.015	2.50	PASS
7.40	30	24	0.011	2.50	PASS
7.40	40	85	0.041	2.50	PASS
7.40	50	58	0.028	2.50	PASS

5 Test Setup Photos of the EUT

Please refer to separated files for Test Setup Photos of the EUT.

6 External Photos of the EUT

Please refer to separated files for External Photos of the EUT.

7 Internal Photos of the EUT

Please refer to separated files for Internal Photos of the EUT.

.....**End of Report**.....