



FCC RADIO TEST REPORT

FCC ID: 2AJRQME103S

Product: Wireless Charger

Trade Name: Maxeye

Model Name: ME103S

Serial Model: ME103A, ME103B, ME103C,
ME103D

Report No.: POCE17091532KRF

Prepared for

Maxeye Smart Technologies Co., Ltd.

Room 6008, Chuangxingda Buiding, Xinan, Baoan,
Shenzhen, China

Prepared by

Shenzhen POCE Technology Co.,Ltd.

Room 502, Bldg. 1, Xinghua Garden, Baoan Road Xixiang,
Baoan District, Shenzhen, China

TEST RESULT CERTIFICATION

Applicant's name : Maxeye Smart Technologies Co., Ltd.
Address : Room 6008, Chuangxingda Buiding, Xinan, Baoan,
Shenzhen, China

Manufacture's Name..... : Maxeye Smart Technologies Co., Ltd.
Address : Room 6008, Chuangxingda Buiding, Xinan, Baoan,
Shenzhen, China

Product description

Product name : Wireless Charger
Model and/or type reference : ME103S, ME103A, ME103B, ME103C, ME103D

Standards : 15.209

Test procedure ANSI C63.10:2013

This device described above has been tested by POCE, and the test results show that the equipment under test (EUT) is in compliance with the FCC requirements. And it is applicable only to the tested sample identified in the report.

This report shall not be reproduced except in full, without the written approval of POCE, this document may be altered or revised by POCE, personal only, and shall be noted in the revision of the document.

Date of Test :
Date (s) of performance of tests : 1 Jul. 2017 ~10 Jul. 2017
Date of Issue : 10 Jul. 2017
Test Result : **Pass**

Testing Engineer :

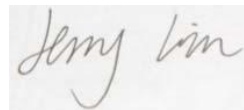

(Jerry Lin)

Technical Manager :



(Jimmy Yao)

Authorized Signatory :



(Terry Yang)

Table of Contents	Page
1 . TEST SUMMARY	4
1.1 TEST FACILITY	5
1.2 MEASUREMENT UNCERTAINTY	5
2 . GENERAL INFORMATION	6
2.1 GENERAL DESCRIPTION OF EUT	6
2.2 DESCRIPTION OF TEST MODES	7
2.3 DESCRIPTION OF TEST SETUP	8
2.4 DESCRIPTION TEST PERIPHERAL AND EUT PERIPHERAL	9
2.5 MEASUREMENT INSTRUMENTS LIST	10
3 . EMC EMISSION TEST	11
3.1 CONDUCTED EMISSION MEASUREMENT	11
3.1.1 POWER LINE CONDUCTED EMISSION	11
3.1.2 TEST PROCEDURE	12
3.1.3 TEST SETUP	12
3.1.4 EUT OPERATING CONDITIONS	12
3.1.5 TEST RESULTS	13
3.2 RADIATED EMISSION MEASUREMENT	15
3.2.1 LIMITS OF RADIATED EMISSION MEASUREMENT	15
3.2.2 TEST PROCEDURE	15
3.2.3 TEST SETUP	17
3.2.4 EUT OPERATING CONDITIONS	17
3.2.5 TEST RESULTS(Blow 30MHZ)	19
3.2.6 TEST RESULTS(30MHZ-1GHZ)	20
4 . ANTENNA REQUIREMENT	22
4.1 STANDARD REQUIREMENT	22
4.2 EUT ANTENNA	22

1. TEST SUMMARY

Test procedures according to the technical standards:

EMC Emission				
Standard	Test Item	Limit	Judgment	Remark
FCC Part 15.207 FCC Part 15.209	Conducted Emission	Class B	PASS	
	Radiated Emission	Class B	PASS	
15.203	Antenna Requirement	--	PASS	

1.1 TEST FACILITY

Shenzhen POCE Technology Co.,Ltd.

Add. : Room 502, Bldg. 1, Xinghua Garden, Baoan Road Xixiang, Baoan District, Shenzhen, China

FCC Registered No.: 222278

1.2 MEASUREMENT UNCERTAINTY

The reported uncertainty of measurement $y \pm U$, where expanded uncertainty U is based on a standard uncertainty multiplied by a coverage factor of $k=2$, providing a level of confidence of approximately **95 %**.

A. Conducted Measurement :

Test Site	Method	Measurement Frequency Range	U, (dB)	NOTE
POCE01	ANSI	150 KHz ~ 30MHz	3.2	

B. Radiated Measurement :

Test Site	Method	Measurement Frequency Range	U, (dB)	NOTE
POCE01	ANSI	30MHz ~ 1000MHz	4.7	
		1GHz ~6GHz	5.0	

2. GENERAL INFORMATION

2.1 GENERAL DESCRIPTION OF EUT

Equipment	Wireless Charger
Brand Name	Maxeye
Model Name.	ME103S
Serial No	ME103A, ME103B, ME103C, ME103D
Model Difference	All the model are the same circuit and RF module, except model names.
Power Supply	DC 5V from USB port
Operation frequency	110-205KHz
Antenna Type	Loop antenna

2.2 DESCRIPTION OF TEST MODES

To investigate the maximum EMI emission characteristics generates from EUT, the test system was pre-scanning tested base on the consideration of following EUT operation mode or test configuration mode which possible have effect on EMI emission level. Each of these EUT operation mode(s) or test configuration mode(s) mentioned above was evaluated respectively.

Pretest Mode	Description
Mode 1	Charging Mode

For Conducted Test	
Final Test Mode	Description
Mode 1	Charging Mode

For Radiated Test	
Final Test Mode	Description
Mode 1	Charging Mode

2.3 DESCRIPTION OF TEST SETUP

E1	E2
----	----

2.4 DESCRIPTION TEST PERIPHERAL AND EUT PERIPHERAL

The EUT has been tested as an independent unit together with other necessary accessories or support units. The following support units or accessories were used to form a representative test configuration during the tests.

Item	Equipment	Mfr/Brand	Model/Type No.	Series No.	Note
E-1	Wireless Charger	Maxeye	ME103S	ME103A, ME103B, ME103C, ME103D	EUT
E-2	GALAXY S7	SAMSUNG	G9350	N/A	

Item	Shielded Type	Ferrite Core	Length	Note

Note:

- (1) The support equipment was authorized by Declaration of Confirmation.
- (2) For detachable type I/O cable should be specified the length in cm in 『Length』 column.

2.5 MEASUREMENT INSTRUMENTS LIST

Radiation Test equipment

Item	Kind of Equipment	Manufacturer	Type No.	Serial No.	Last calibration	Calibrated until	Calibration period
1	Spectrum Analyzer	Agilent	E4407B	MY45108040	2016.09.06	2017.09.05	1 year
2	Test Receiver	R&S	ESPI	101318	2016.09.07	2017.09.06	1 year
3	Bilog Antenna	TESEQ	CBL6111D	31216	2016.09.06	2017.09.05	1 year
4	50Ω Coaxial Switch	Anritsu	MP59B	6200264416	2016.09.07	2017.09.06	1 year
5	Spectrum Analyzer	ADVANTEST	R3132	150900201	2016.09.07	2017.09.06	1 year
6	Horn Antenna	EM	EM-AH-10180	2011071402	2016.09.06	2017.09.05	1 year
7	Horn Ant	Schwarzbeck	BBHA 9170	9170-181	2016.09.06	2017.09.05	1 year
8	Amplifier	EM	EM-30180	060538	2016.12.22	2017.12.21	1 year
9	Loop Antenna	ARA	PLA-1030/B	1029	2016.09.08	2017.09.07	1 year
10	Power Meter	R&S	NRVS	100696	2016.09.06	2017.09.05	1 year
11	Power Sensor	R&S	URV5-Z4	0395.1619.05	2016.09.06	2017.09.05	1 year

Conduction Test equipment

Item	Kind of Equipment	Manufacturer	Type No.	Serial No.	Last calibration	Calibrated until	Calibration period
1	Test Receiver	R&S	ESCI	101160	2016.09.06	2017.09.05	1 year
2	LISN	R&S	ENV216	101313	2016.08.24	2017.08.23	1 year
3	LISN	EMCO	3816/2	00042990	2016.08.24	2017.08.23	1 year
4	50Ω Coaxial Switch	Anritsu	MP59B	6200264417	2016.09.07	2017.09.06	1 year
5	Passive Voltage Probe	R&S	ESH2-Z3	100196	2016.09.07	2017.09.06	1 year
6	Absorbing clamp	R&S	MOS-21	100423	2016.09.08	2017.09.07	1 year

3. EMC EMISSION TEST

3.1 CONDUCTED EMISSION MEASUREMENT

3.1.1 POWER LINE CONDUCTED EMISSION (Frequency Range 150KHz-30MHz)

FREQUENCY (MHz)	Class B (dBuV)	
	Quasi-peak	Average
0.15 -0.5	66 - 56 *	56 - 46 *
0.50 -5.0	56.00	46.00
5.0 -30.0	60.00	50.00

Note:

- (1) The tighter limit applies at the band edges.
- (2) The limit of " * " marked band means the limitation decreases linearly with the logarithm of the frequency in the range.

The following table is the setting of the receiver

Receiver Parameters	Setting
Attenuation	10 dB
Start Frequency	0.15 MHz
Stop Frequency	30 MHz
IF Bandwidth	9 kHz

3.1.2 TEST PROCEDURE

- a. The EUT was placed 0.4 meters from the horizontal ground plane with EUT being connected to the power mains through a line impedance stabilization network (LISN). All other support equipments powered from additional LISN(s). The LISN provide 50 Ohm/ 50uH of coupling impedance for the measuring instrument.
- b. Interconnecting cables that hang closer than 40 cm to the ground plane shall be folded back and forth in the center forming a bundle 30 to 40 cm long.
- c. I/O cables that are not connected to a peripheral shall be bundled in the center. The end of the cable may be terminated, if required, using the correct terminating impedance. The overall length shall not exceed 1 m.
- d. LISN at least 80 cm from nearest part of EUT chassis.
- e. For the actual test configuration, please refer to the related Item –EUT Test Photos.

3.1.3 TEST SETUP

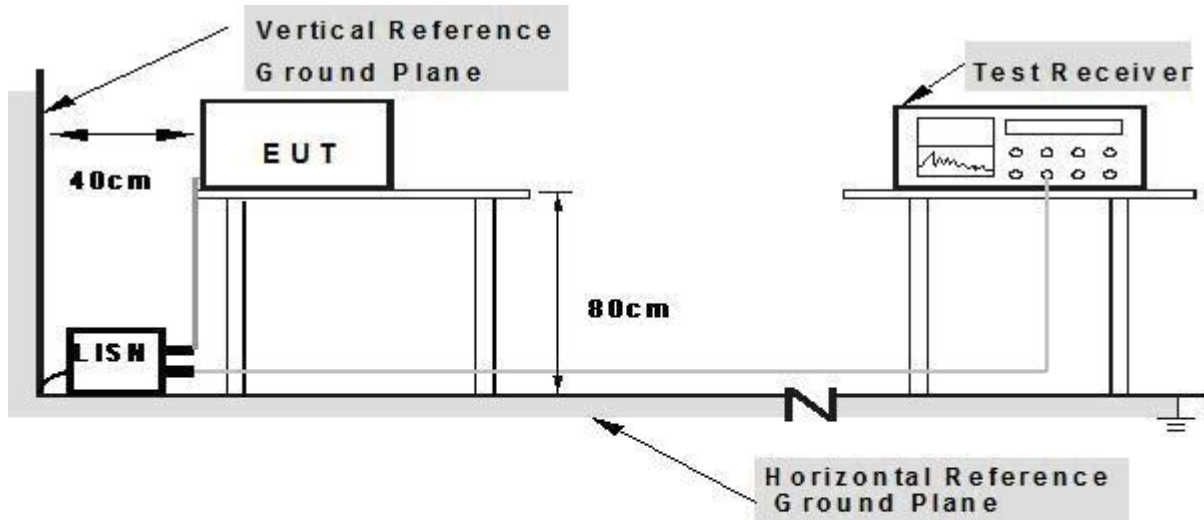

Note: 1. Support units were connected to second LISN.

2. Both of LISNs (AMN) are 80 cm from EUT and at least 80 cm from other units and other metal planes

3.1.4 EUT OPERATING CONDITIONS

The EUT tested system was configured as the statements of 2.3 Unless otherwise a special operating condition is specified in the follows during the testing.

3.1.5 TEST RESULTS

EUT:	Wireless Charger	Model Name. :	ME103S
Temperature:	26 °C	Relative Humidity:	54%
Pressure:	1010hPa	Phase :	L
Test Voltage :	AC120V/60Hz	Test Mode:	Charging

Frequency (MHz)	Reading Level (dBμV)	Correct Factor (dB)	Measure-ment (dBμV)	Limits (dBμV)	Margin (dB)	Detector Type
0.1900	36.87	10.00	46.87	64.03	-17.16	QP
0.1900	31.16	10.00	41.16	54.03	-12.87	AVG
0.5060	34.63	10.02	44.65	56.00	-11.35	QP
0.5060	28.61	10.02	38.63	46.00	-7.37	AVG
1.1140	30.67	10.06	40.73	56.00	-15.27	QP
1.1140	19.17	10.06	29.23	46.00	-16.77	AVG
2.4380	28.88	10.05	38.93	56.00	-17.07	QP
2.4380	20.14	10.05	30.19	46.00	-15.81	AVG
14.4820	34.15	10.25	44.40	60.00	-15.60	QP
14.4820	16.25	10.25	26.50	50.00	-23.50	AVG

Remark:

1. All readings are Quasi-Peak and Average values.
2. Factor = Insertion Loss + Cable Loss.

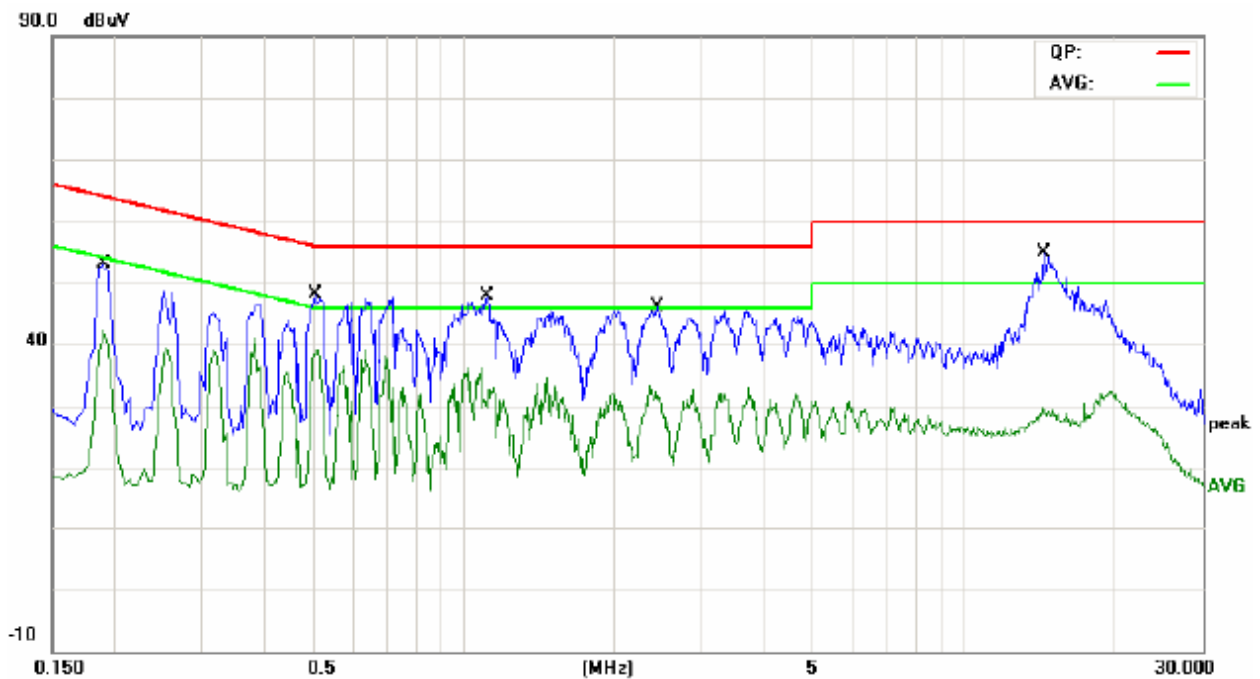

EUT:	Wireless Charger	Model Name. :	ME103S
Temperature:	26 °C	Relative Humidity:	54%
Pressure:	1010hPa	Phase :	N
Test Voltage :	AC120V/60Hz	Test Mode:	Charging

Frequency (MHz)	Reading Level (dBμV)	Correct Factor (dB)	Measure-ment (dBμV)	Limits (dBμV)	Margin (dB)	Detector Type
0.5020	33.19	10.02	43.21	56.00	-12.79	QP
0.5020	24.57	10.02	34.59	46.00	-11.41	AVG
1.0100	30.88	10.06	40.94	56.00	-15.06	QP
1.0100	20.01	10.06	30.07	46.00	-15.93	AVG
2.3900	27.30	10.05	37.35	56.00	-18.65	QP
2.3900	16.10	10.05	26.15	46.00	-19.85	AVG
2.4539	27.03	10.04	37.07	56.00	-18.93	QP
2.4539	15.21	10.04	25.25	46.00	-20.75	AVG
4.6140	28.47	9.97	38.44	56.00	-17.56	QP
4.6140	16.89	9.97	26.86	46.00	-19.14	AVG

Remark:

1. All readings are Quasi-Peak and Average values.
2. Factor = Insertion Loss + Cable Loss.

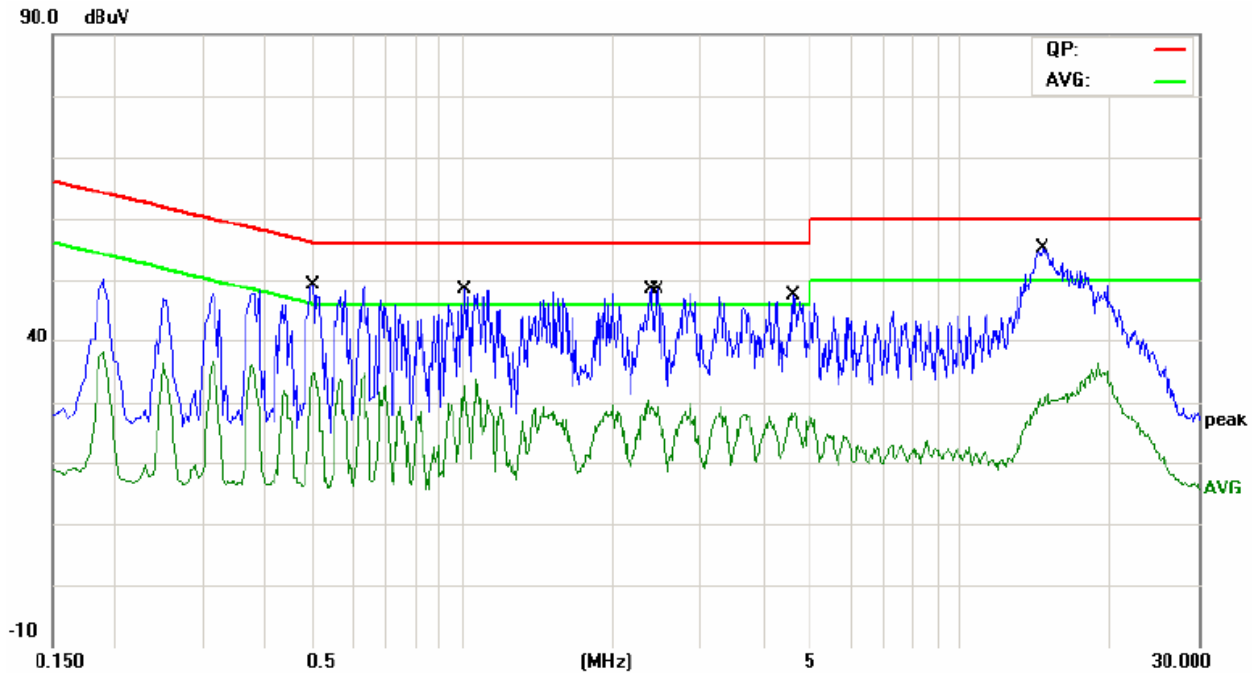

3.2 RADIATED EMISSION MEASUREMENT

3.2.1 RADIATED EMISSION LIMITS (FREQUENCY RANGE 9KHZ-1000MHZ)

20dBc in any 100 kHz bandwidth outside the operating frequency band. In case the emission fall within the restricted band specified on 15.205(a), then the 15.209(a) limit in the table below has to be followed. (unintentional radiator)

Frequencies (MHz)	Field Strength (micorvolts/meter)	Measurement Distance (meters)
0.009~0.490	2400/F(KHz)	300
0.490~1.705	24000/F(KHz)	30
1.705~30.0	30	30
30~88	100	3
88~216	150	3
216~960	200	3
Above 960	500	3

The following table is the setting of the receiver

Spectrum Parameter	Setting
Attenuation	Auto
Start Frequency	1000 MHz
Stop Frequency	10th carrier harmonic
RB / VB (emission in restricted band)	1 MHz / 1 MHz for Peak, 1 MHz / 10Hz for Average

Receiver Parameter	Setting
Attenuation	Auto
Start ~ Stop Frequency	9kHz~150kHz / RB 200Hz for QP
Start ~ Stop Frequency	150kHz~30MHz / RB 9kHz for QP
Start ~ Stop Frequency	30MHz~1000MHz / RB 120kHz for QP

3.2.2 TEST PROCEDURE

- a. The measuring distance of at 3 m shall be used for measurements at frequency up to 1GHz. For frequencies above 1GHz, any suitable measuring distance may be used.
- b. The EUT was placed on the top of a rotating table 0.8 meters above the ground at a 10 meter open area test site. The table was rotated 360 degrees to determine the position of the highest radiation.
- c. The height of the equipment or of the substitution antenna shall be 0.8 m; the height of the test antenna shall vary between 1 m to 4 m. Both horizontal and vertical polarizations of the antenna are set to make the measurement.
- d. The initial step in collecting conducted emission data is a spectrum analyzer peak detector mode pre-scanning the measurement frequency range. Significant peaks are then marked and then Quasi Peak detector mode re-measured, above 1G Average detector mode will be instead.

- e. If the Peak Mode measured value compliance with and lower than Quasi Peak Mode Limit, the EUT shall be deemed to meet QP(AV) Limits and then no additional QP Mode measurement performed.
- f. For the actual test configuration, please refer to the related Item –EUT Test Photos.

3.2.3 DEVIATION FROM TEST STANDARD

No deviation

3.2.3 TEST SETUP

(A) Radiated Emission Test-Up Frequency Below 30MHz

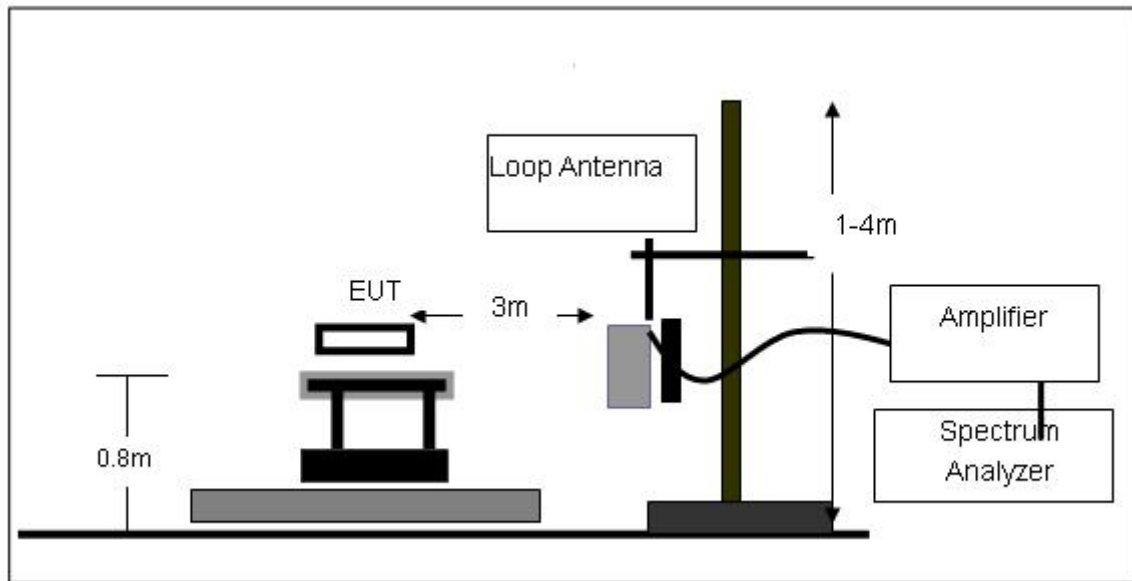

(B) Radiated Emission Test Set-Up Frequency Below 1 GHz

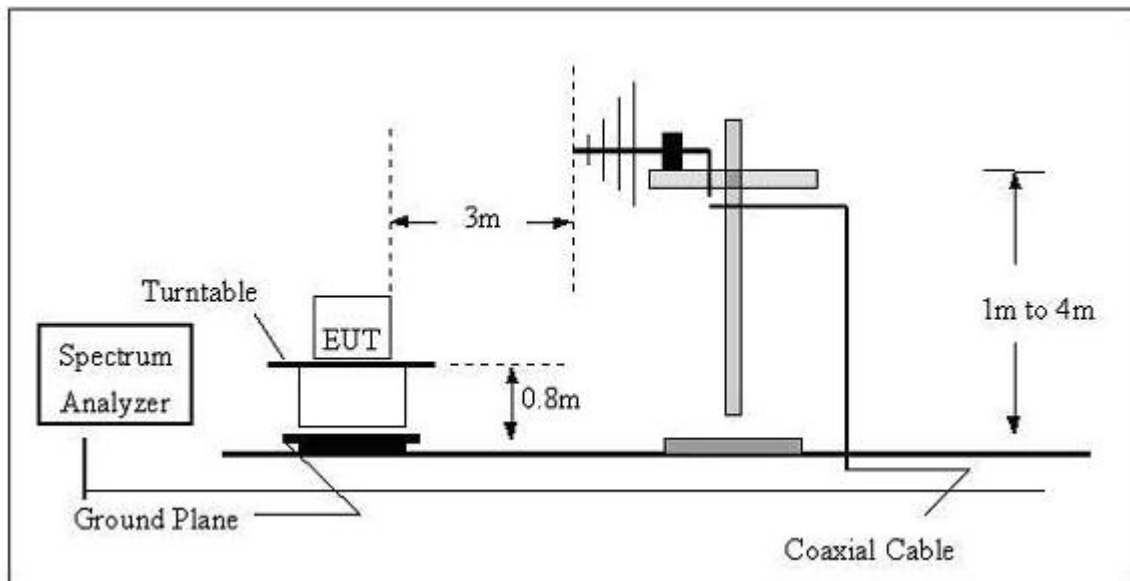

(C) Radiated Emission Test Set-Up Frequency Above 1GHz

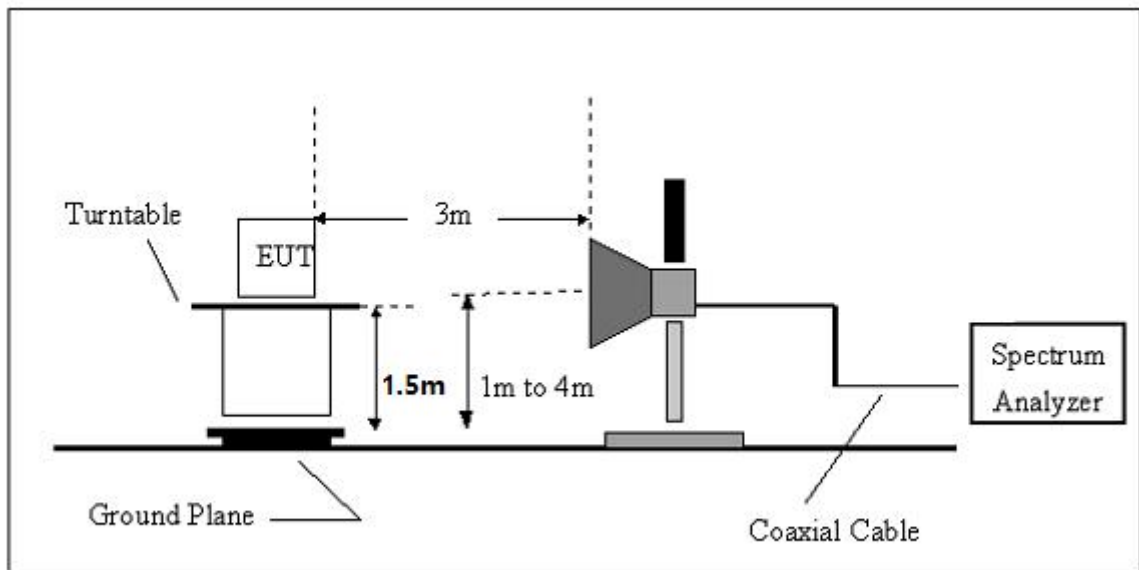

3.2.4 EUT OPERATING CONDITIONS

The EUT tested system was configured as the statements of 2.3 Unless otherwise a special operating condition is specified in the follows during the testing.

3.2.5 TEST RESULTS(Blow 30MHZ)

Job No.: 011610151I **Plarization:** Horizontal
Standard: FCC PART15 C _3m
Test item: Radiation Test **Temp.(C)/Hum.(%RH):** 24.4(C)/50%RH
Test Mode: Charging **Distance:** 3m

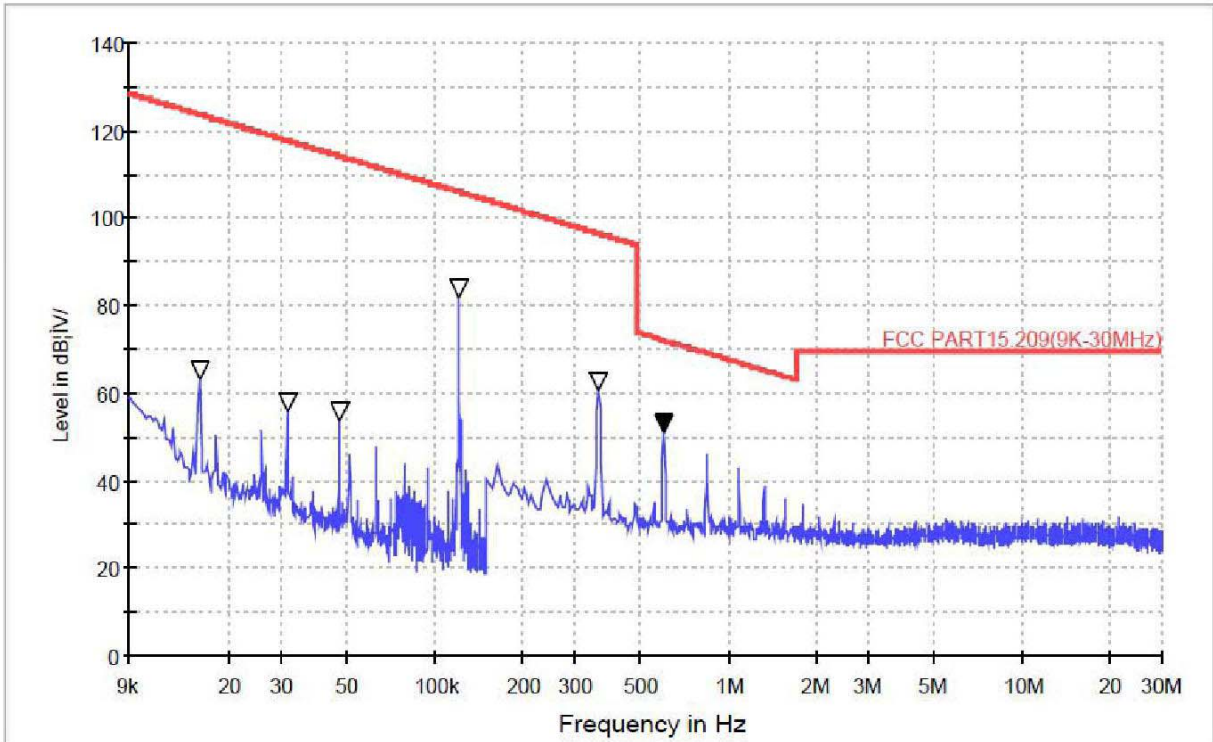

Frequency (MHz)	Read Level (dBuV)	Antenna Factor (dB/m)	Cable Loss (dB)	Preamp Factor (dB)	Level (dBuV/m)	Remark
0.0158	41.874	18.59	2.38	0	62.844	Pass
0.0314	34.708	18.67	2.39	0	55.768	Pass
0.0472	31.784	19.45	2.38	0	53.614	Pass
PP 0.1208	58.689	20.58	2.39	0	81.659	Pass
0.3620	36.063	21.53	2.76	0	60.353	Pass
0.6020	25.646	22.86	2.53	0	51.036	Pass

Note: pp is Fundamental Field strength.

3.2.6 TEST RESULTS(30MHZ-1GHZ)

EUT:	Wireless Charger	Model Name :	ME103S
Temperature:	20 °C	Relative Humidity:	48%
Pressure:	1010 hPa	Test Voltage :	AC120V
Test Mode :	Charging	Polarization :	Horizontal

Frequency (MHz)	Meter Reading (dBμV)	Factor (dB)	Emission Level (dBμV/m)	Limits (dBμV/m)	Margin (dB)	Detector Type
33.2111	12.94	16.79	29.73	40.00	-10.27	QP
49.1865	16.07	8.62	24.69	40.00	-15.31	QP
125.0066	23.52	12.21	35.73	43.50	-7.77	QP
135.0319	21.72	12.25	33.97	43.50	-9.53	QP
233.3487	20.62	10.99	31.61	46.00	-14.39	QP
661.1504	11.16	23.67	34.83	46.00	-11.17	QP

Remark:

1. Factor = Antenna Factor + Cable Loss – Pre-amplifier.

70.0 dBμV/m

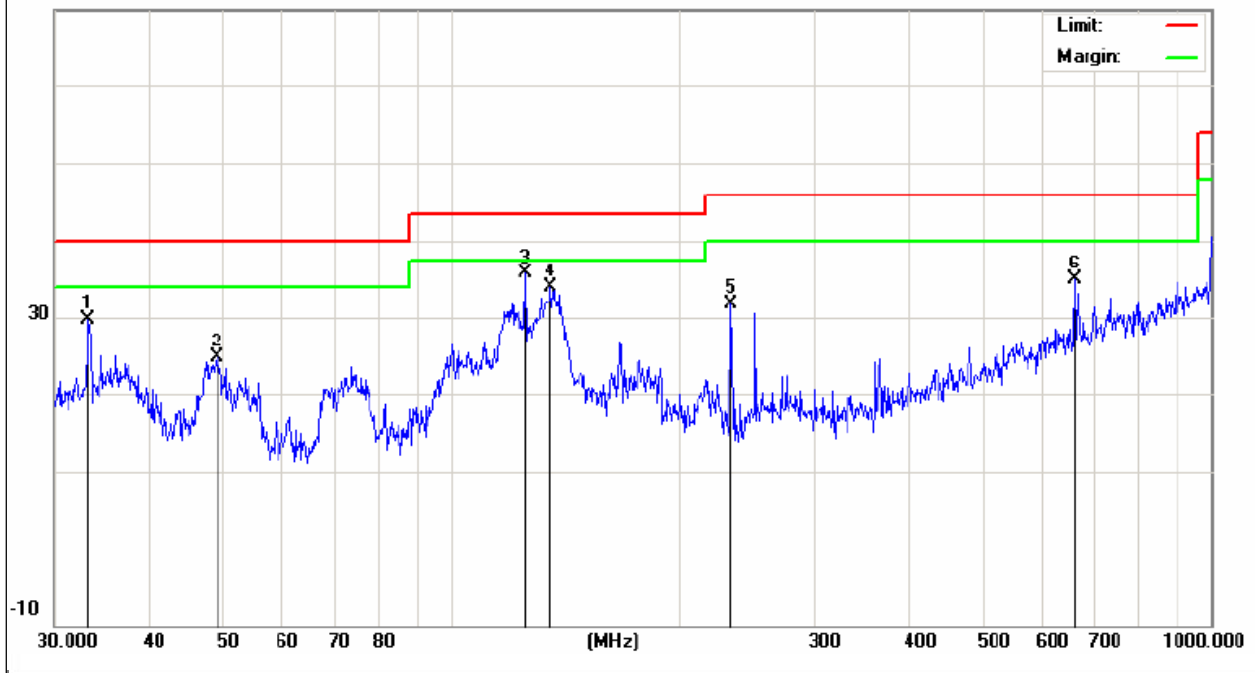

EUT:	Wireless Charger	Model Name :	ME103S
Temperature:	20 °C	Relative Humidity:	48%
Pressure:	1010 hPa	Test Voltage :	AC120V
Test Mode :	Charging	Polarization :	Vertical

Frequency (MHz)	Meter Reading (dBµV)	Factor (dB)	Emission Level (dBµV/m)	Limits (dBµV/m)	Margin (dB)	Detector Type
55.8046	13.82	6.04	19.86	40.00	-20.14	QP
125.0066	21.99	12.21	34.20	43.50	-9.30	QP
139.3611	17.70	12.18	29.88	43.50	-13.62	QP
232.5318	29.21	10.94	40.15	46.00	-5.85	QP
360.4476	22.51	16.46	38.97	46.00	-7.03	QP
480.5276	12.15	20.04	32.19	46.00	-13.81	QP

Remark:

1. Factor = Antenna Factor + Cable Loss – Pre-amplifier.

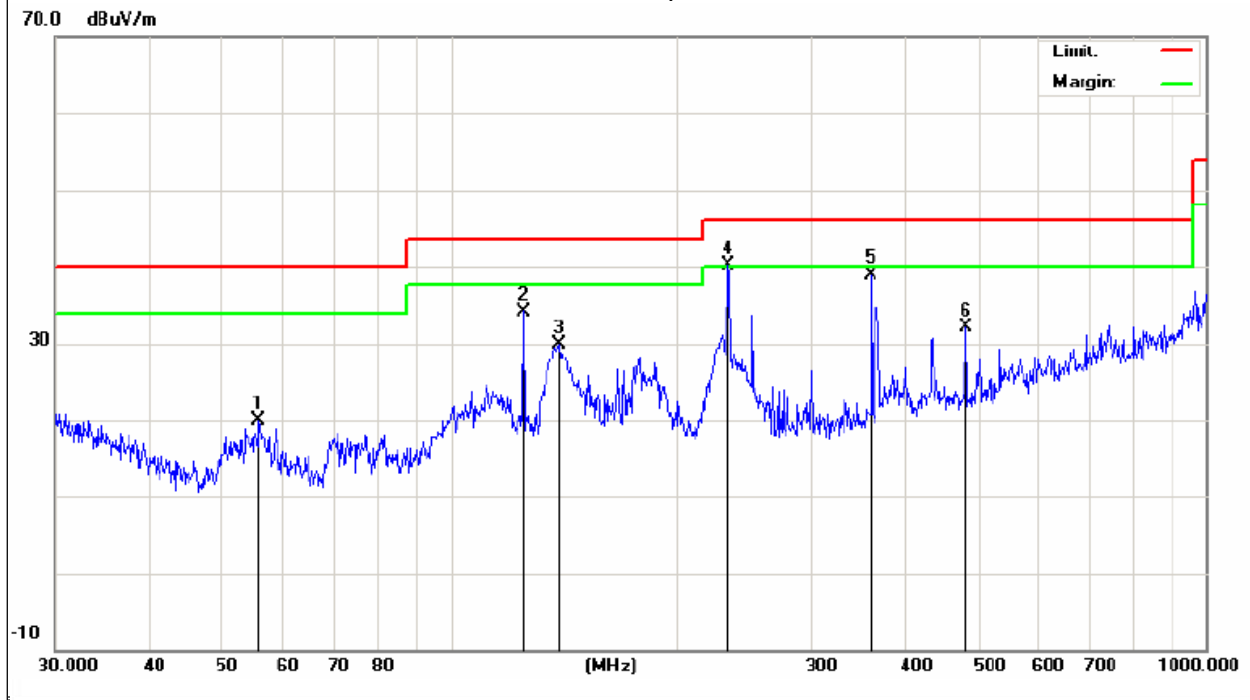

4. ANTENNA REQUIREMENT

4.1 STANDARD REQUIREMENT

15.203 requirement: For intentional device, according to 15.203: an intentional radiator shall be designed to ensure that no antenna other than that furnished by the responsible party shall be used with the device.

4.2 EUT ANTENNA

The EUT antenna is a Loop Antenna. It comply with the standard requirement.

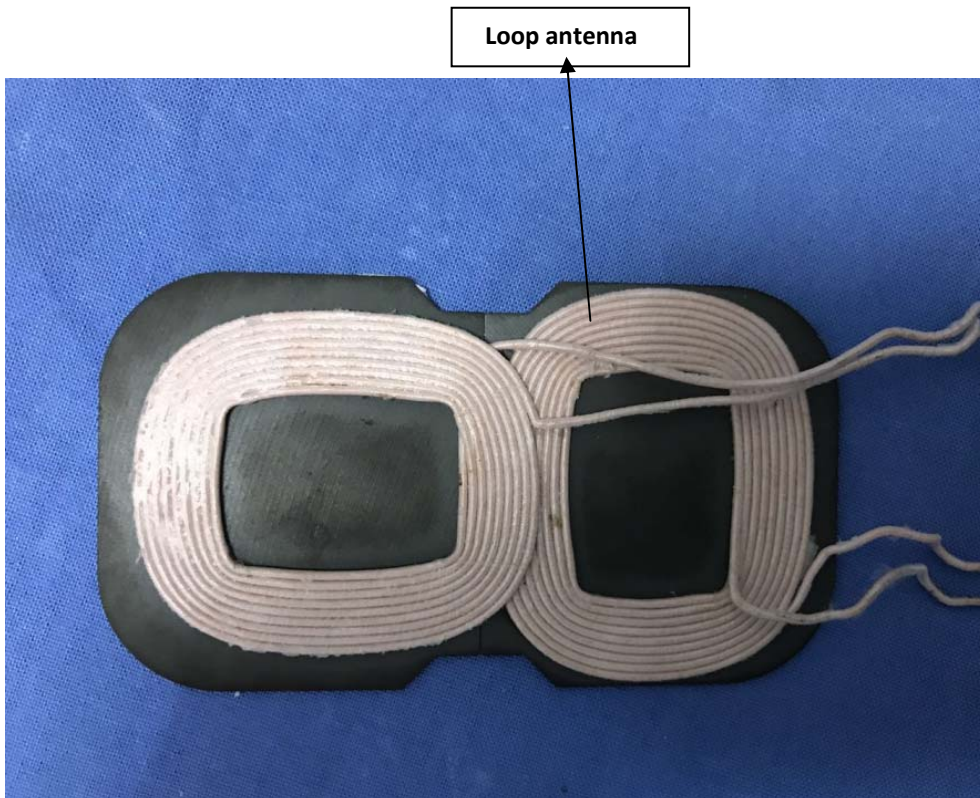

RADIATED SPURIOUS EMISSION

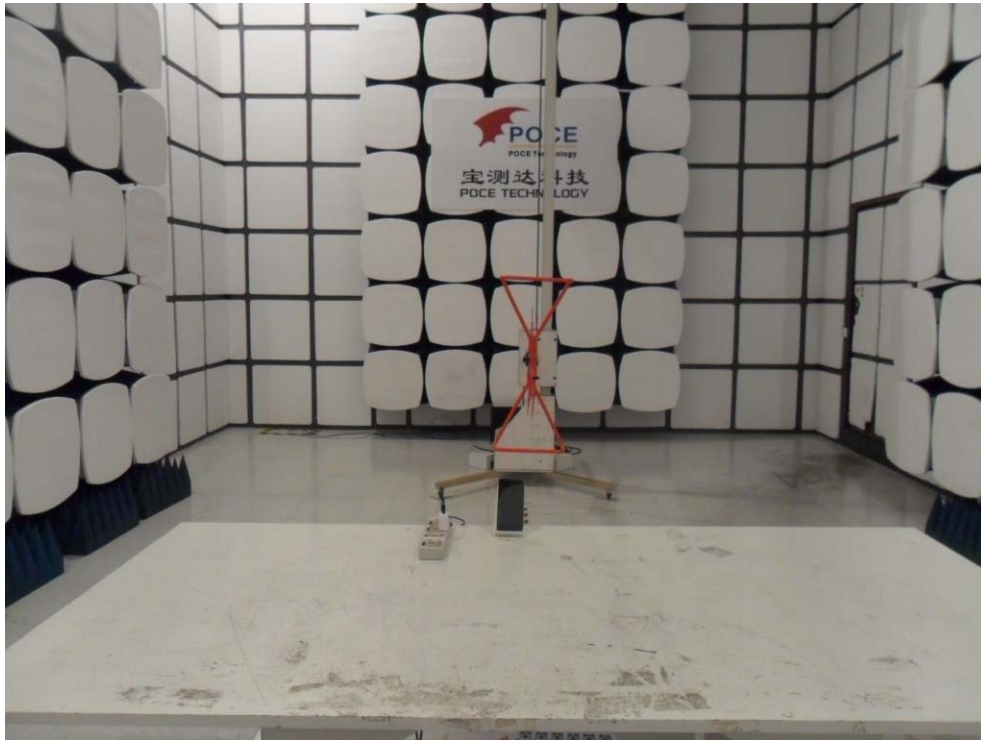

CONDUCTED EMISSION TEST

