

TEST REPORT

KOSTEC CO., Ltd. 28(175-20, Annyeong-dong) 406-gil sejaro, Hwaseong-si, Gyeonggi-do, Korea Tel:031-222-4251, Fax:031-222-4252	Report No: KST-FCR-150003(1)	 KOSTEC Co., Ltd. http://www.kostec.org
<p>1. Applicant</p> <ul style="list-style-type: none">• Name : SamYoungCeletra. Co.,Ltd.• Address : 110, Geomdan-ro, Seo-gu, Incheon, South Korea <p>2. Test Item</p> <ul style="list-style-type: none">• Product Name: UHF Transceiver• Model Name : SY4050-LM• Brand Name: -• FCC ID: 2AJRJ-SY4050-LM <p>3. Manufacturer</p> <ul style="list-style-type: none">• Name : SamYoungCeletra. Co.,Ltd.• Address : 110, Geomdan-ro, Seo-gu, Incheon, South Korea <p>4. Date of Test : 2015. 09. 23 ~ 2015. 09. 25</p> <p>5. Test Method Used : FCC CFR 47, Part 90, ANSI/TIA-603-D-2010</p> <p>6. Test Result : Compliance</p> <p>7. Note: -</p>		
<p>Supplementary Information</p> <p>The device bearing the brand name and FCC ID specified above has been shown to comply with the applicable technical standards as indicated in the measurement report and was tested in accordance with measurement procedures specified in ANSI/TIA-603-D-2010.</p> <p>We attest to the accuracy of data and all measurements reported herein were performed by KOSTEC Co., Ltd. and were made under Chief Engineer's supervision. We assume full responsibility for the completeness of these measurements and vouch for the qualifications of all persons taking them.</p>		
<p>The results shown in this test report refer only to the sample(s) tested unless otherwise stated.</p>		
Affirmation	Tested by Name : Lee, Mi-Young (Signature)	Technical Manager Name : Park, Gyeong-Hyeon (Signature)
<p style="text-align: center;">2016. 09.12</p> <p style="text-align: center;">KOSTEC Co., Ltd.</p>		

Table of Contents

1. GENERAL INFORMATION	4
1.1 Test Facility	4
1.2 Location	4
2. EQUIPMENT DESCRIPTION	5
3. SYSTEM CONFIGURATION FOR TEST	6
3.1 Characteristics of equipment.....	6
3.2 Used peripherals list.....	6
3.3 Product Modification.....	6
3.4 Operating Mode.....	6
3.5 Test Setup of EUT	6
3.6 Table for Carrier Frequencies.....	7
3.7 Modulation.....	7
3.8 Used Test Equipment List.....	8
4. SUMMARY TEST RESULTS	10
5. MEASUREMENT RESULTS	11
5.1 RF Output Power.....	11
5.2 Modulation Characteristecs.....	12
5.3 Occupied Bandwidth & 26 dB Bandwidth.....	15
5.4 Emission Mask	24
5.5 Spurious Emission On Antenna Port.....	30
5.6 Transmitter Radiated Unwanted Emissions	33
5.7 Frequency Stability.....	36
5.8 Transmitter Frequency Behavior	38

Revision History of test report

Rev.	Revisions	Effect page	Reviewed	Date
-	Initial issue	All	Gyeong Hyeon, Park	2015. 09. 30
1	Retest low frequency	All	Gyeong Hyeon, Park	2015. 11. 02
2	Revised section 5.2.1 and 5.3.6	12, 16 - 23	Gyeong Hyeon, Park	2015. 11. 06
3	Correct the value of emission designator for digital.	5,7	Gyeong Hyeon, Park	2015. 11. 09
4	Revise applicant's name according to request for applicant	All	Gyeong Hyeon, Park	2016. 09. 12

1. GENERAL INFORMATION

1.1 Test Facility

Test laboratory and address

KOSTEC Co., Ltd.

128(175-20,Annyeong-dong)406-gil sejaro, Hwaseong-si Gyeonggi-do, Korea

The open area field test site and conducted measurement facility are used for these testing. This site at was fully described in a reports submitted to the Federal Communications Commission (FCC).

The facility also complies with the radiated and conducted test site criteria set forth in ANSI C 63.4-2014 and ANSI/TIA-603-D-2010.

The Federal Communications Commission (FCC) has the reports on file and KOSTEC Co., Ltd. is designated No. KR0041 under MRA with USA.

Registration information

KCC (Korea Communications Commission) Number : KR0041

KOLAS(Korea Laboratory Accreditation Scheme) Number : 232

IC Registration Site Number : 8305A-1

1.2 Location



2. EQUIPMENT DESCRIPTION

The product specification described herein was declared by manufacturer. And refer to user's manual for the details.

Equipment Name	UHF Transceiver
Model No	SY4050-LM
Type of Equipment	Licensed Non-Broadcast Transmitter Held to Face
Intended Operating Environment	Restricted to Occupational Use only
Serial Number	Prototype
Primary User Functions of EUT	2-Way Wireless Voice & Data Communication
RF Output Power Rating	5 Watt (High) / 2 Watt (Low)
Operating Frequency Range	406.1 - 440 MHz
RF Output Impedance	50 Ω
Channel Spacing	12.5 kHz
Modulation	FM for analog voice 4FSK for digital Voice and data
Occupied Bandwidth (99%)	9.68 kHz (for 12.5 kHz Channel Spacing / Analog) 7.95 kHz (for 12.5 kHz Channel Spacing / Digital)
Emission Designation*	11K0F3E, 7K950F1D, 7K95F1E
Power Source	Li-ion battery / 7.4 VDC nominal / 2.600 mAh
Antenna Description	Antenna 1(Main): HW-423W-CT405 Whip antenna, 0 dBi Antenna 2(Optional): HW-423H-CT405 Helical Antenna, -2 dBi
FCC ID	2AJRJ-SY4050-LM
Remark	The above DUT's information was declared by manufacturer. Please refer to the specifications or user manual for more detailed description.

3. SYSTEM CONFIGURATION FOR TEST

3.1 Characteristics of equipment

The Equipment Under Test (EUT) use for UHF transceiver.

3.2 Used peripherals list

Description	Model No.	Serial No.	Manufacture	Remark
AC/DC adaptor	KSAS0121200100VO	None	Kuantech(Beihai)CO.,Ltd.	
Charger	WLC-300	J000F	Winnertech	
Battery	WLB-2600	J000G	Winnertech	
Tube.ear/mic	WEP-100	None	Winnertech	

3.3 Product Modification

N/A

3.4 Operating Mode

* Constantly transmitting with a modulated carrier at maximum power on the bottom, middle and top channels as required using the supported modulation types.

* The EUT has one transmit/receive RF port. RF cables and attenuators connecting the test equipment to the EUT ports were calibrated before use and the calibration data incorporated into the conducted measurement results.

* Radiated emissions tests were performed with antenna ports terminated.

3.5 Test Setup of EUT

The measurements were taken in continuous transmit mode.

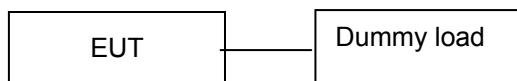

3.6 Table for Carrier Frequencies

Modulation Type	Tested Channel	Channel separation (kHz)	Test freq. (MHz)
Analog	Low	12.5	406.1125
	Mid		420.0000
	High		440.0000
Digital	Low	12.5	406.1125
	Mid		420.0000
	High		440.0000

3.7 Modulation

Channel space	Mode	Modulation	Description
12.5 kHz	Analog Voice	11K0F3E	<p>$BW = 2M + 2DK$, where M = maximum modulating frequency in Hz, D = peak deviation in Hz, and K=1, is as follows:</p> <p>In this case the maximum modulating frequency is 3.0 kHz with a 2.5 kHz deviation.</p> <p>$BW = 2(M+D) = 2*(3.0kHz + 2.5kHz) = 11kHz$ (11K0 designator)</p>
12.5 kHz	Digital Data	7K95F1D	<p>Measurement's per Rule Part 2.202(c)(4) where employed because Part 2.202(g) Table III A formulation produces an excessive result using the value of K recommended in the Table. Therefore, the 99% energy rule (Title 47 CFR 2.989) was used for digital mode and is more accurate than Carson's rule. It states that 99 % of the modulation energy falls within X kHz, which in this case is 7.95 kHz (7K95 designator).</p> <p>This product utilizes a Time Division Multiple Access (TDMA) protocol. The complete emissions designator for this transmitter is 7K95F1D.</p>
12.5 kHz	Digital Voice	7K95F1E	<p>Measurement's per Rule Part 2.202(c)(4) where employed because Part 2.202(g) Table III A formulation produces an excessive result using the value of K recommended in the Table. Therefore, the 99% energy rule (Title 47 CFR 2.989) was used for digital mode and is more accurate than Carson's rule. It states that 99 % of the modulation energy falls within X kHz, which in this case is 7.95 kHz (7K95 designator).</p> <p>This product utilizes a Time Division Multiple Access (TDMA) protocol. The complete emissions designator for this transmitter is 7K95F1E.</p>

3.8 Used Test Equipment List

No.	Instrument	Model	S/N	Manufacturer	Due to cal date	Cal interval	used
1	T & H Chamber	EY-101	90E14260	TABAI ESPEC	2016.09.17	1 year	<input checked="" type="checkbox"/>
2	Constant switch Tester	DS-COT	None	Dong sung Ele.	N/A	N/A	<input type="checkbox"/>
3	Vibration Tester	70UA	L90016	IDEX Co.,Ltd	N/A	N/A	<input type="checkbox"/>
4	Vibration Meter	VM-6360	N225098	LANDTEK	2016.04.07	1 year	<input type="checkbox"/>
5	Falling Tester	SWD-8000	None	Sinwoo	N/A	N/A	<input type="checkbox"/>
6	Spectrum Analyzer	8563E	3846A10662	Agilent Technology	2016.02.05	1 year	<input type="checkbox"/>
7	Spectrum Analyzer	8593E	3710A02859	Agilent Technology	2016.02.05	1 year	<input type="checkbox"/>
8	Spectrum Analyzer	FSV30	20-353063	Rohde& Schwarz	2016.02.05	1 year	<input checked="" type="checkbox"/>
9	EMI Test Receiver	ESCI7	100823	Rohde& Schwarz	2016.02.02	1 year	<input checked="" type="checkbox"/>
10	EMI Test Receiver	ESI	834000/002	Rohde& Schwarz	2016.02.05	1 year	<input checked="" type="checkbox"/>
11	Vector Signal Analyzer	89441A	3416A02620	Agilent Technology	2016.02.05	1 year	<input type="checkbox"/>
12	Network Analyzer	8753ES	US39172348	AGILENT	2016.09.16	1 year	<input type="checkbox"/>
13	EPM Series Power meter	E4418B	GB39512547	Agilent Technology	2016.02.05	1 year	<input checked="" type="checkbox"/>
14	RF Power Sensor	E9300A	MY41496631	Agilent Technology	2016.02.05	1 year	<input checked="" type="checkbox"/>
15	Microwave Frequency Counter	5352B	2908A00480	Agilent Technology	2016.02.02	1 year	<input type="checkbox"/>
16	Modulation Analyzer	8901A	3538A07071	Agilent Technology	2016.02.05	1 year	<input checked="" type="checkbox"/>
17	Audio Analyzer	8903B	3514A16919	Agilent Technology	2016.02.02	1 year	<input checked="" type="checkbox"/>
18	Audio Telephone Analyzer	DD-5601CID	520010281	CREDIX	2016.02.02	1 year	<input type="checkbox"/>
19	Digital storage Oscilloscope	TDS3052	B015962	Tektronix	2016.09.16	1 year	<input checked="" type="checkbox"/>
20	ESG-D Series Signal Generator	E4436B	US39260458	Agilent Technology	2016.02.04	1 year	<input checked="" type="checkbox"/>
21	ESG Vector Signal Generator	E4438C	MY42083133	Agilent Technology	2016.09.16	1 year	<input checked="" type="checkbox"/>
22	Vector Signal Generator	SMBV100A	257557	Rohde & Schwarz	2016.01.10	1 year	<input type="checkbox"/>
23	Tracking Source	85645A	070521-A1	Agilent Technology	2016.02.05	1 year	<input type="checkbox"/>
24	SLIDAC	None	0207-4	Myoung sung Ele.	2016.02.02	1 year	<input type="checkbox"/>
25	DC Power supply	DRP-5030	9028029	Digital Electronic Co.,Ltd	2016.02.03	1 year	<input type="checkbox"/>
26	DC Power supply	6038A	3440A12674	Agilent Technology	2016.02.02	1 year	<input checked="" type="checkbox"/>
27	DC Power supply	E3610A	KR24104505	Agilent Technology	2016.02.02	1 year	<input type="checkbox"/>
28	DC Power supply	UP-3005T	68	Unicon Co.,Ltd	2016.02.02	1 year	<input type="checkbox"/>
29	DC Power Supply	SM 3004-D	114701000117	DELTAELEKTRONIKA	2016.02.02	1 year	<input type="checkbox"/>
30	Dummy Load	8173	3780	Bird Electronic Co., Corp	2016.02.04	1 year	<input checked="" type="checkbox"/>
31	Attenuator	50FH-030-500	140410 9433	JEW Industries Inc.	2016.02.04	1 year	<input type="checkbox"/>
32	Attenuator	765-20	9703	Narda	2016.09.16	1 year	<input type="checkbox"/>
33	Attenuator	8498A	3318A09485	HP	2016.02.04	1 year	<input type="checkbox"/>
34	Step Attenuator	8494B	3308A32809	HP	2016.02.05	1 year	<input type="checkbox"/>
35	Step Attenuator	8495D	3308A01464	HP	2016.02.05	1 year	<input checked="" type="checkbox"/>
36	Power divider	11636B	51212	HP	2016.02.04	1 year	<input type="checkbox"/>
37	3Way Power divider	KPDSU3W	00070365	KMW	2016.09.16	1 year	<input type="checkbox"/>
38	Band rejection filter	WTR-BRF2442-84NN	09020001	WAVE TECH Co.,LTD	2016.02.04	1 year	<input type="checkbox"/>
39	White noise audio filter	ST31EQ	101902	SoundTech	2016.09.16	1 year	<input type="checkbox"/>
40	Dual directional coupler	778D	17693	HEWLETT PACKARD	2016.02.04	1 year	<input type="checkbox"/>
41	Dual directional coupler	772D	2839A00924	HEWLETT PACKARD	2016.02.04	1 year	<input type="checkbox"/>
42	Band rejection filter	3TNF-0006	26	DOVER Tech	2016.02.04	1 year	<input type="checkbox"/>
43	Band rejection filter	3TNF-0008	317	DOVER Tech	2016.02.04	1 year	<input type="checkbox"/>
44	Band rejection filter	3TNF-0007	311	DOVER Tech	2016.02.04	1 year	<input type="checkbox"/>
45	Highpass Filter	WHJS1100-10EF	1	WAINWRIGHT	2016.02.04	1 year	<input type="checkbox"/>
46	Highpass Filter	WHJS3000-10EF	1	WAINWRIGHT	2016.02.04	1 year	<input type="checkbox"/>
47	Radio Communication Alalyzer	MT8815A	6200429622	ANRITSU	2016.02.04	1 year	<input type="checkbox"/>
48	CDMA Mobile Station Test Set	E8285A	US40081298	AGILENT	2016.02.05	1 year	<input type="checkbox"/>
49	WideBand Radio Communication Tester	CMW500	102276	Rohde & Schwarz	2016.04.02	1 year	<input type="checkbox"/>

No.	Instrument	Model	S/N	Manufacturer	Due to cal date	Cal interval	used
50	RF Up/Down Converter	DCP-1780	980901003	CREDIX	2016.02.04	1 year	<input type="checkbox"/>
51	DECT Test set	8923B	3829U00364	HP	2016.02.05	1 year	<input type="checkbox"/>
52	DECT Test set	CMD60	840677/005	Rohde& Schwarz	2016.09.16	1 year	<input type="checkbox"/>
53	Loop Antenna	6502	9203-0493	EMCO	2017.06.04	2 year	<input checked="" type="checkbox"/>
54	Dipole Antenna	HZ-12	100005	Rohde & Schwarz	2016.07.01	2 year	<input type="checkbox"/>
55	Dipole Antenna	HZ-13	100007	Rohde & Schwarz	2016.07.01	2 year	<input type="checkbox"/>
56	BiconiLog Antenna	3142B	1745	EMCO	2016.06.16	2 year	<input checked="" type="checkbox"/>
57	Horn Antenna	3115	9605-4834	EMCO	2016.06.16	2 year	<input checked="" type="checkbox"/>
58	Horn Antenna	3115	2996	EMCO	2016.02.26	2 year	<input type="checkbox"/>
59	Horn Antenna	BBHA9170	BBHA9170152	SCHWARZBECK	2017.04.10	2 year	<input type="checkbox"/>
60	Signal Generator	SMT-06	100552	Rohde & Schwarz	2016.02.04	1 year	<input type="checkbox"/>
61	HYGRO-Thermograph	NSII-Q	1611545	SATO	2016.09.21	1 year	<input type="checkbox"/>
62	Barometer	7612	81134	SATO	2016.01.20	2 year	<input type="checkbox"/>
63	Multi meter	DM-313	S60901832	LG Precision Co.,Ltd	2016.02.02	1 year	<input type="checkbox"/>
64	Antenna Mast(OSA)	AT14	None	Daeil EMC	N/A	N/A	<input type="checkbox"/>
65	Turn table(OSA)	None	None	Daeil EMC	N/A	N/A	<input type="checkbox"/>
66	RF Amplifier(OSA)	8447D	2944A07881	AGILENT	2016.02.04	1 year	<input type="checkbox"/>
67	Antenna Master(3)	AT13	None	AUDIX	N/A	N/A	<input checked="" type="checkbox"/>
68	Turn Table(3)	None	None	AUDIX	N/A	N/A	<input checked="" type="checkbox"/>
69	PREAMPLIFIER(3)	8449B	3008A02577	Agilent	2016.02.05	1 year	<input checked="" type="checkbox"/>
70	Antenna Master(10)	MA4000-EP	None	inno systems GmbH	N/A	N/A	<input checked="" type="checkbox"/>
71	Turn Table(10)	None	None	inno systems GmbH	N/A	N/A	<input checked="" type="checkbox"/>
72	AMPLIFIER(10)	TK-PA6S	120009	TESTEK	2016.02.02	1 year	<input checked="" type="checkbox"/>
73	Vernier Calipers	None	8280373	Mitutoyo	2016.09.17	1 year	<input type="checkbox"/>

4. SUMMARY TEST RESULTS

Description of Test	FCC Rule	Reference Clause	Used	Test Result
RF Output Power	Part 90.205	Clause 5.1	<input checked="" type="checkbox"/>	Compliance
Modulation Characteristecs	Part 2.1047(a), 90.242(b)(8)	Clause 5.2	<input checked="" type="checkbox"/>	Compliance
Occupied Bandwidth	Part 90.209	Clause 5.3	<input checked="" type="checkbox"/>	Compliance
Emission Mask	Part 90.210	Clause 5.4	<input checked="" type="checkbox"/>	Compliance
Frequency Stability	Part 90.213	Clause 5.5	<input checked="" type="checkbox"/>	Compliance
Spurious Emission On Antenna Port	Part 90.210	Clause 5.6	<input checked="" type="checkbox"/>	Compliance
Transmitter Radiated Unwanted Emissions	Part 90.210	Clause 5.7	<input checked="" type="checkbox"/>	Compliance
Transmitter Frequency Behavior	Part 90.214	Clause 5.8	<input checked="" type="checkbox"/>	Compliance
<p>Compliance/pass : The EUT complies with the essential requirements in the standard. Not Compliance : The EUT does not comply with the essential requirements in the standard. N/A : The test was not applicable in the standard.</p>				

5. MEASUREMENT RESULTS

5.1 RF Output Power

5.1.1 Standard Applicable [FCC §90.205 & 2.1046]

5.1.2 Test Environment conditions

- Ambient temperature : (20 - 21) °C
- Relative Humidity : (43 - 45) % R.H.

5.1.3 Measurement Procedure

The transmitter output was connected to the spectrum analyzer with an attenuator. The power output shall be monitored and recorded and no adjustment shall be made to the transmitter after the test has begun, except as noted below: If the power output is adjustable, measurements shall be made for the highest and lowest power levels.

The spectrum analyzer is set to the as follows :

- RBW : 100 kHz
- VBW : 300 kHz

5.1.4 Test setup

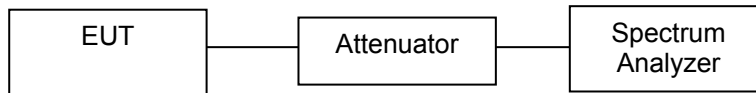

5.1.5 Measurement Result

Modulation	Frequency [MHz]	Power Level	Conducted output Power [dBm]	Conducted output Power [W]	Limit [dBm]	Test Results
Analog	406.1125	Low	32.83	1.92	1.6 - 2.4 W	Compliance
	420.0000	Low	32.82	1.91		Compliance
	440.0000	Low	32.50	1.78		Compliance
	406.1125	High	36.25	4.22	4 - 6 W	Compliance
	420.0000	High	36.87	4.86		Compliance
	440.0000	High	36.97	4.98		Compliance
Digital	406.1125	Low	32.71	1.87	1.6 - 2.4 W	Compliance
	420.0000	Low	32.66	1.85		Compliance
	440.0000	Low	32.46	1.76		Compliance
	406.1125	High	36.69	4.67	4 - 6 W	Compliance
	420.0000	High	36.67	4.65		Compliance
	440.0000	High	36.81	4.80		Compliance

5.2 Modulation Characteristecs

5.2.1 Standard Applicable [FCC §Part 2.1047(a)]

2.1047(b): Equipment which employs modulation limiting. A curve or family of curves showing the percentage of modulation versus the modulation input voltage shall be supplied. The information submitted shall be sufficient to show modulation limiting capability throughout the range of modulating frequencies and input modulating signal levels employed.

Recommended frequency deviation characteristics are given below:

CH spacing	Frequency deviation
12.5 kHz	2.5 kHz

Part 2.1047(a) A curve or equivalent data showing the frequency response of the audio modulating circuit over a range of 100 to 5000 Hz shall be submitted. For equipment required to have an audio low-pass filter, a curve showing the frequency response of the filter, or of all circuitry installed between the modulation limiter and the modulated stage shall be submitted.

90.242(b)(8) Recommended audio filter attenuation characteristics are given below:

Audio freq.	Minimum Attenuation Rel. to 1 kHz Attenuation
3 - 20 kHz	$60 \log_{10}(f/3)$ dB where f is in kHz
20 - 30 kHz	50 dB

5.2.2 Test Environment conditions

- Ambient temperature : (20 - 21) °C • Relative Humidity : (43 - 45) % R.H.

5.2.3 Measurement Procedure

- Modulation Limit

The carrier frequency deviation was measured with the tone adjust the audio input for 60 % of rated system deviation at 1 kHz using this level as a reference (0 dB) and vary the input level from -20 to +20 dB. Record the frequency deviation obtained as a function of the input level at frequencies 0.1, 0.5, 1.0, 3.0 and 5.0 kHz. The maximum deviation was recorded at each test condition.

- Audio frequency response

The audio input level needed for a particular percentage of modulation was measured in accordance with ANSI/TIA 603-D: 2010. The audio input curves versus modulation are shown below. Curves are provided for audio input frequencies of 300, 1000, and 3000 Hz.

- Test freq: Mid

5.2.4 Test setup

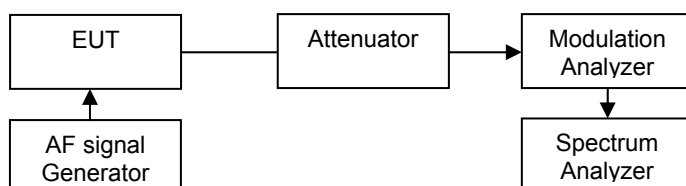

5.2.5 Measurement Result

- Modulation Limit

Audio input Level (dB)	Frequency Deviation (kHz)			Limit (kHz)
	@ 300 Hz	@ 1 kHz	@ 3 kHz	
20	1.74	2.33	2.00	2.5
15	1.64	2.30	2.00	2.5
10	1.26	2.17	1.86	2.5
5	0.72	1.86	1.85	2.5
0	0.42	1.24	1.85	2.5
-5	0.27	0.70	1.55	2.5
-10	0.13	0.32	0.69	2.5
-15	0.11	0.24	0.49	2.5
-20	0.08	0.14	0.26	2.5

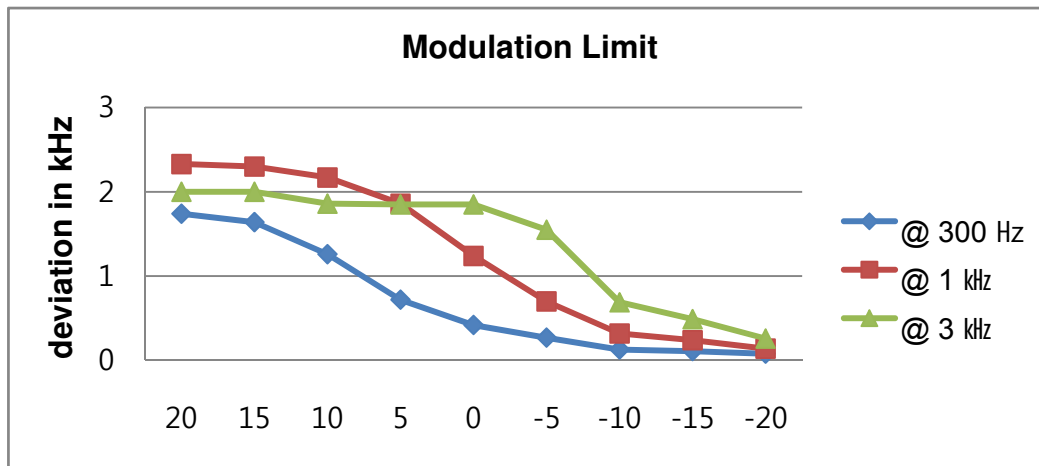

• Audio frequency response

Audio Frequency (Hz)	Response Attenuation (dB)	Audio Frequency (Hz)	Response Attenuation (dB)
300	-9.61	2 800	4.08
400	-7.42	2 900	3.95
500	-5.61	3 000	3.38
600	-4.04	3 100	2.46
700	-2.88	3 200	0.22
800	-1.73	3 300	-5.96
900	-0.85	3 400	-13.32
1 000	-0.02	3 500	-19.22
1 200	1.42	4 000	-45.86
1 400	2.57	5 000	-58.67
1 600	3.16	6 000	-61.86
1 800	3.25	7 000	-61.86
2 000	3.19	8 000	-61.86
2 100	3.32	9 000	-61.86
2 200	3.37	10 000	-61.86
2 300	3.42	12 000	-
2 400	3.29	14 000	-
2 500	3.58	16 000	-
2 600	3.78	18 000	-
2 700	3.95	20 000	-

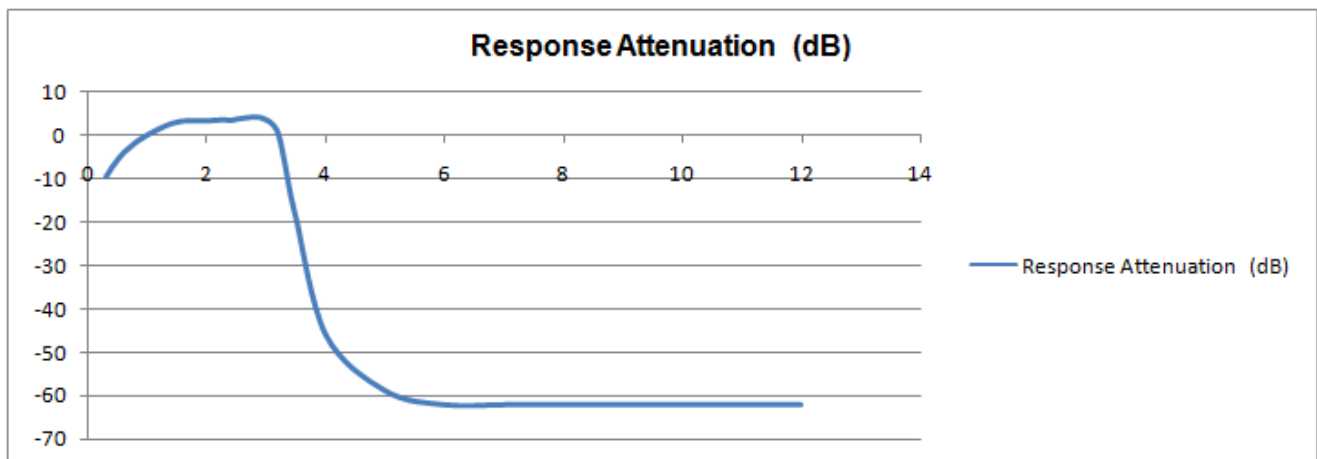

5.3 Occupied Bandwidth & 26 dB Bandwidth

5.3.1 Standard Applicable [FCC §90.209 & 2.1049]

According to FCC Part 90 Section 90.209: The authorized bandwidth shall be 11.25 kHz for 12.5 kHz channel separation and 6 kHz for 6.25 kHz channel separation.

5.3.2 Test Environment conditions

- Ambient temperature : (20 - 21) °C • Relative Humidity : (43 - 45) % R.H.

5.3.3 Measurement Procedure

1. The EUT was modulated by 2.5 kHz Sine wave audio signal, The level of the audio signal employed is 16 dB greater than that necessary to produce 50 % of rated system deviation. Rated system deviation is 2.5 kHz (12.5 kHz channel spacing).
2. The transmitter output (antenna port) was connected to the spectrum analyzer in peak hold mode.
3. Measure the maximum width of the emission that is 26 dB down from the peak of the emission. The 99 % occupied bandwidth is the frequency bandwidth of the signal power at the 99 % channel power of occupied bandwidth.

The spectrum analyzer is set to the as follows :

- RBW : 300 Hz
- VBW : >3 x RBW
- Detector function : peak
- Trace : max hold

5.3.4 Test setup

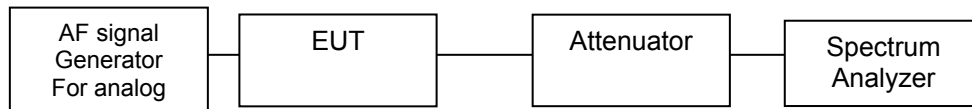

5.3.5 Measurement Result

Modulation	Frequency [MHz]	Power Level	99 % Bandwidth [MHz]	26 dB Bandwidth [MHz]	Limit [dBm]	Test Results
Analog	406.1125	Low	9.08	10.37	≤ 11.25	Compliance
	420.0000	Low	9.64	10.38		Compliance
	440.0000	Low	9.64	10.38		Compliance
	406.1125	High	9.16	10.40	≤ 11.25	Compliance
	420.0000	High	9.60	10.38		Compliance
	440.0000	High	9.68	10.38		Compliance
Digital (Voice and Data)	406.1125	Low	7.73	10.12	≤ 11.25	Compliance
	420.0000	Low	7.77	10.12		Compliance
	440.0000	Low	7.95	10.12		Compliance
	406.1125	High	7.95	10.03	≤ 11.25	Compliance
	420.0000	High	7.82	10.20		Compliance
	440.0000	High	7.82	10.07		Compliance

5.3.6 Test Plot (26 dB band width for analog)

Power level: Low

CH Low

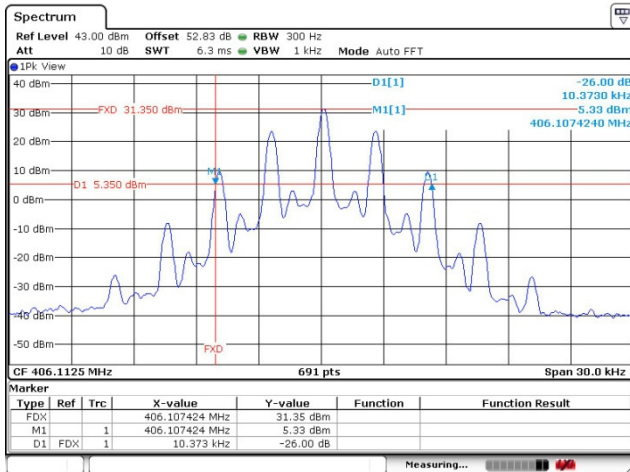

CH Middle

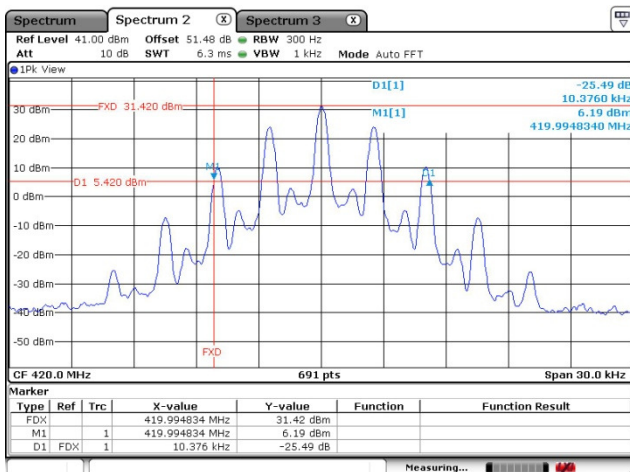

CH High

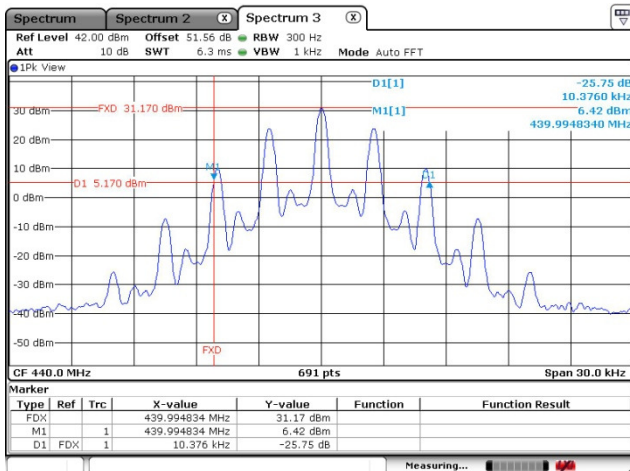

Power level: High

CH Low

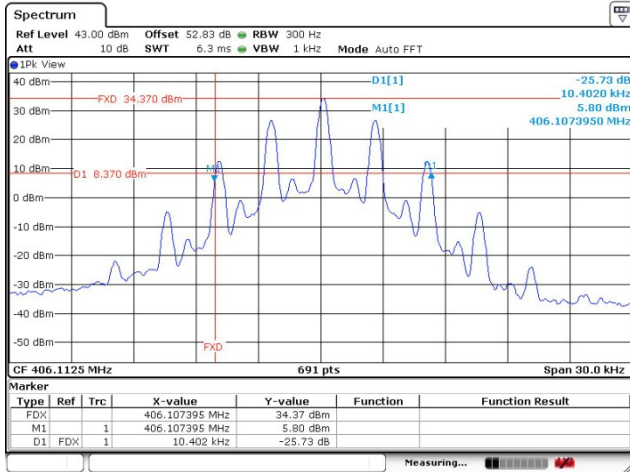

CH Middle

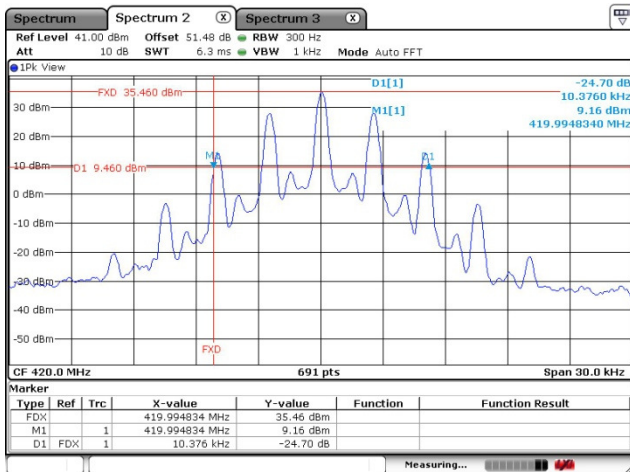

CH High

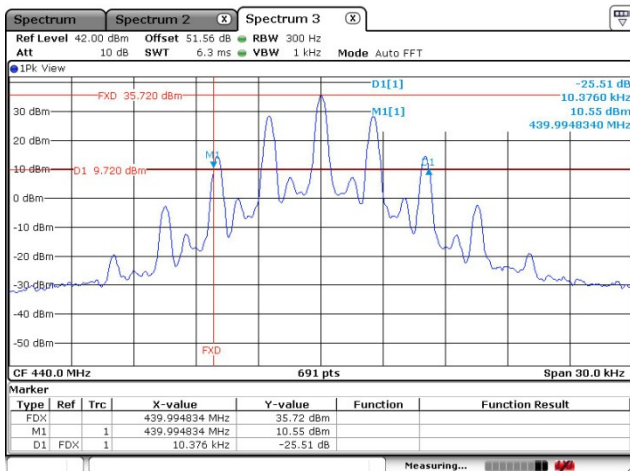

Test Plot (99 % band width for analog)

Power level: Low

CH Low

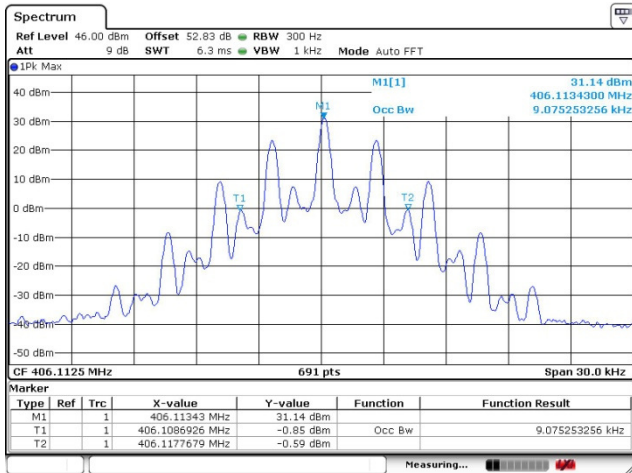

CH Middle

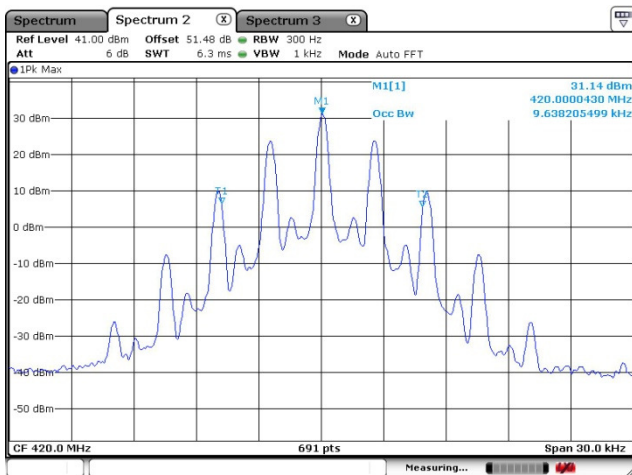

CH High

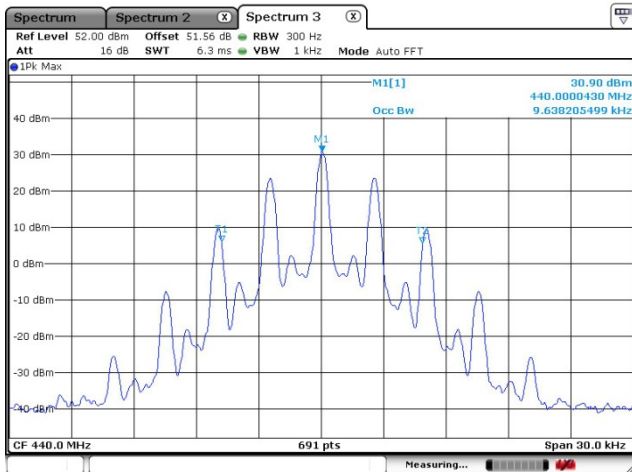

Power level: High

CH Low

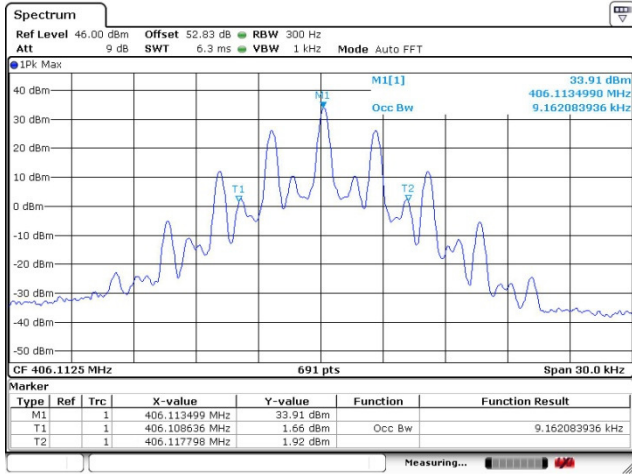

CH Middle

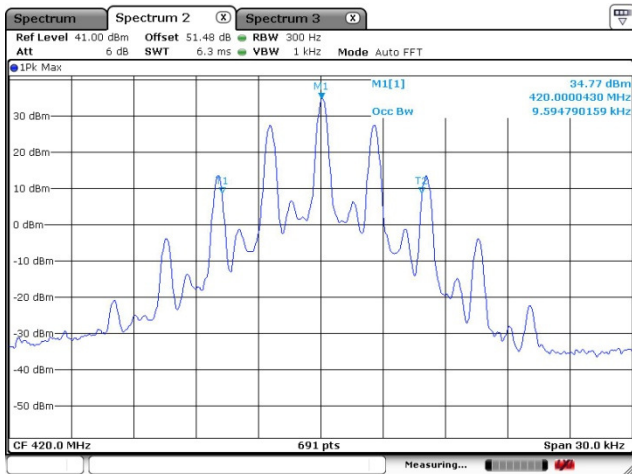

CH High

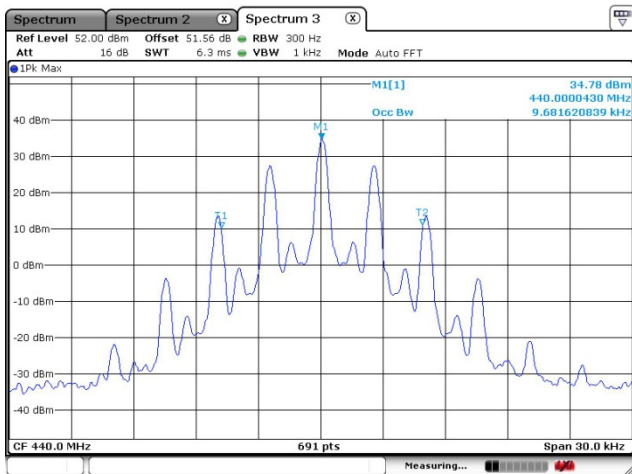

Test Plot (26 dB band width for digital)

Power level: Low

CH Low

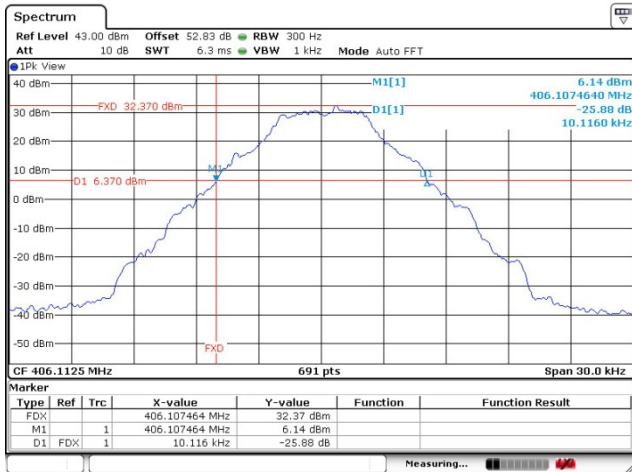

CH Middle

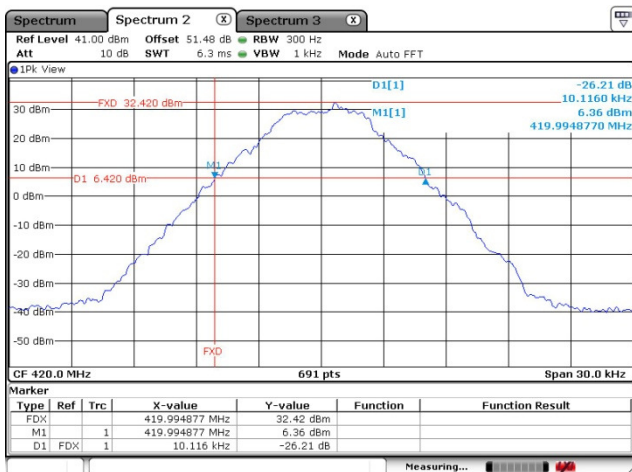

CH High

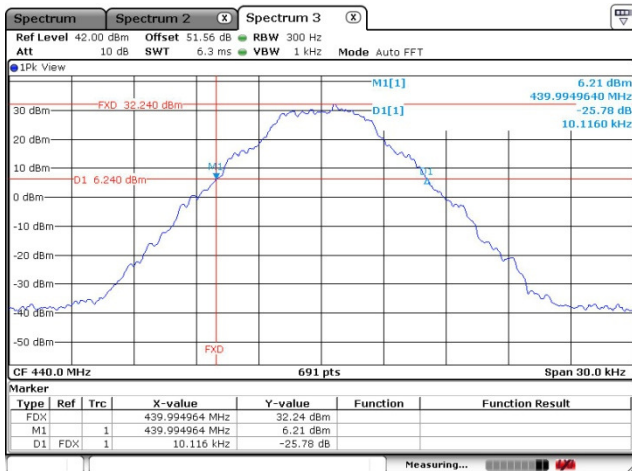

Power level: High

CH Low

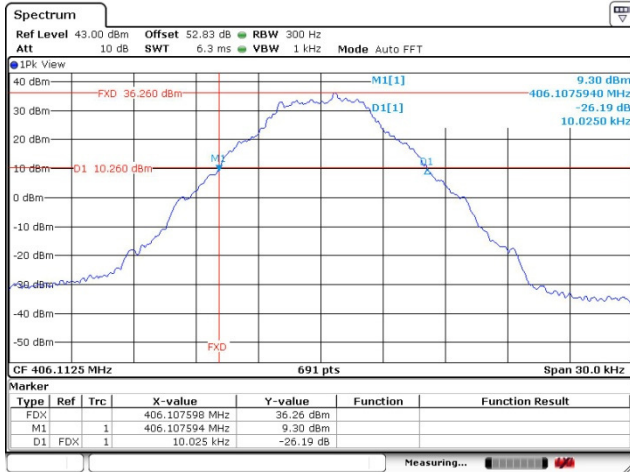

CH Middle

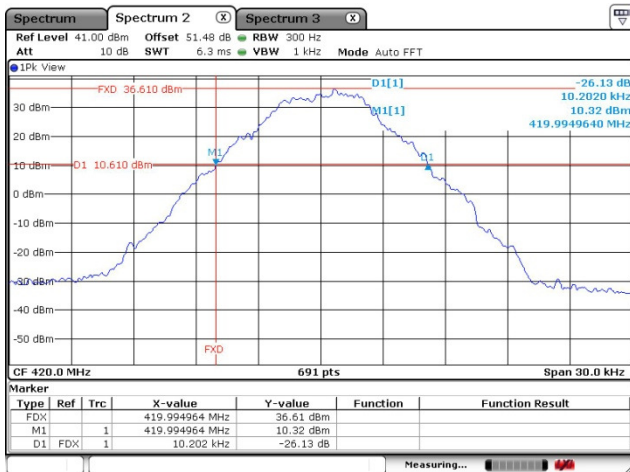

CH High

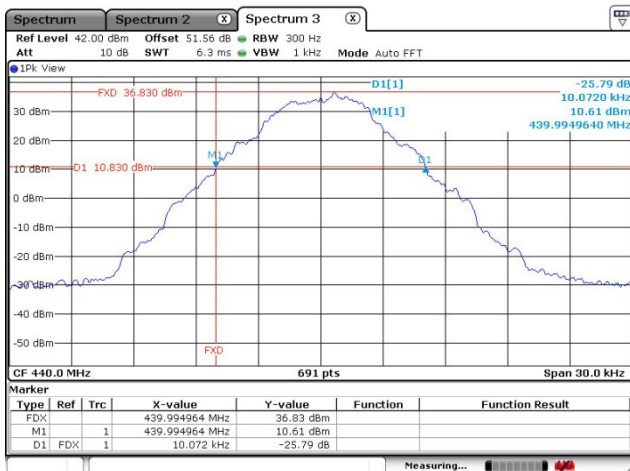

Test Plot (99 % band width for digital)

Power level: Low

CH Low

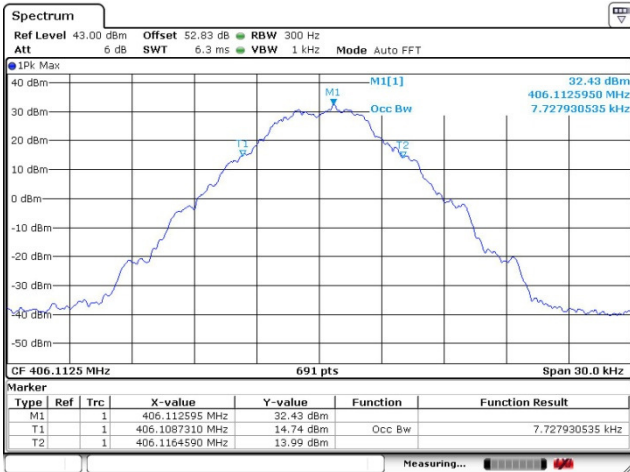

CH Middle

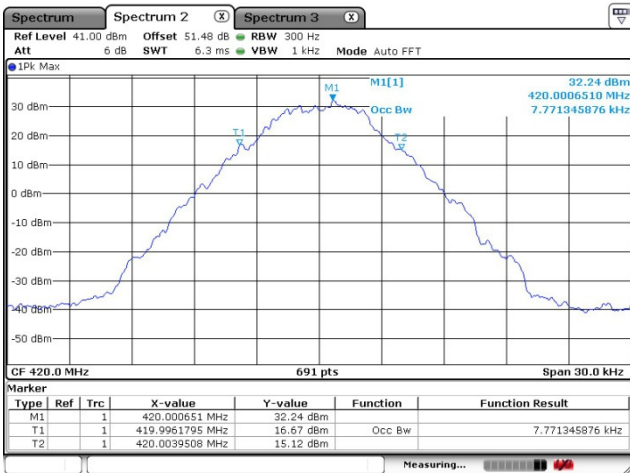

CH High

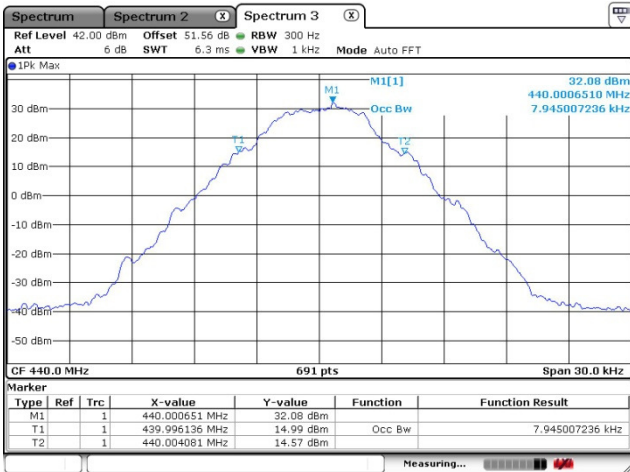

Power level: High

CH Low

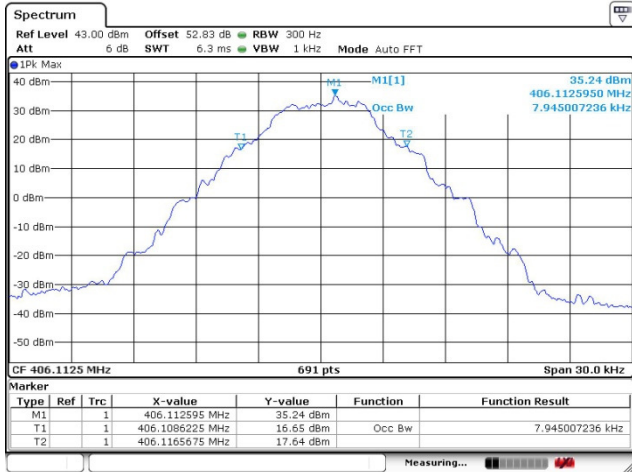

CH Middle

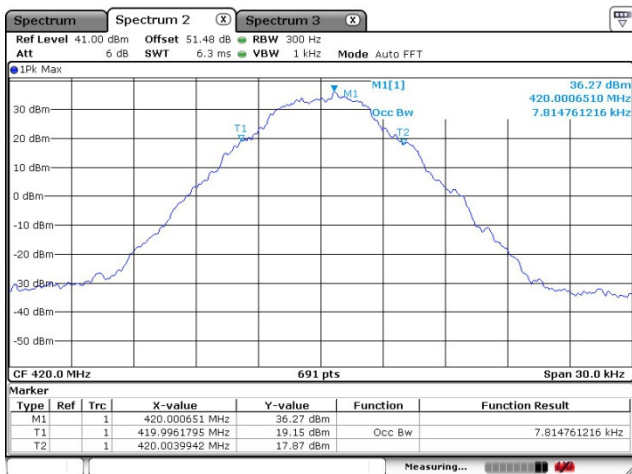

CH High

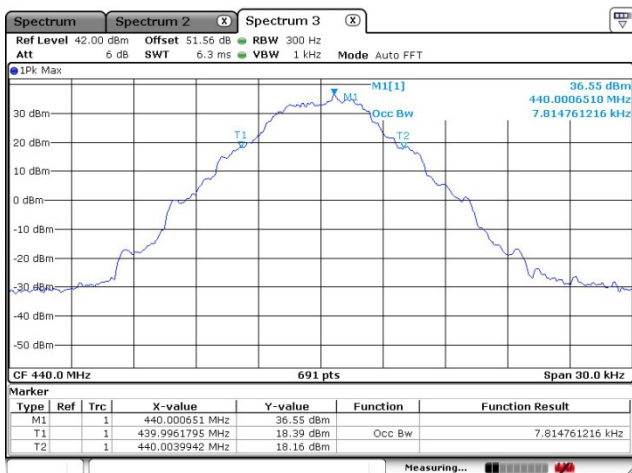

5.4 Emission Mask

5.4.1 Standard Applicable [FCC §90.210]

Emission mask D: For transmitters designed to operate with a 12.5 kHz channel bandwidth, any emission must be attenuated below the power (P) of the highest emission contained within the authorized bandwidth as follows:

- (1) On any frequency from the center of the authorized bandwidth f_0 to 5.625 kHz removed from f_0 : Zero dB.
- (2) On any frequency removed from the center of the authorized bandwidth by a displacement frequency (f_d in kHz) of more than 5.625 kHz but no more than 12.5 kHz: At least $7.27(f_d - 2.88)$ dB.
- (3) On any frequency removed from the center of the authorized bandwidth by a displacement frequency (f_d in kHz) of more than 12.5 kHz: At least $50 + 10 \log(P)$ dB or 70 dB, whichever is the lesser attenuation.

5.4.2 Test Environment conditions

- Ambient temperature : (20 - 21) °C,
- Relative Humidity : (43 - 45) % R.H.

5.4.3 Measurement Procedure

- Voice or Digital Modulation Through a Voice Input Port @ 2.1049(c)(i)

The transmitter was modulated by a 2.5 kHz tone signal at an input level 16 dB greater than that required to produce 50 % modulation (e.g.: ± 2.5 kHz peak deviation at 1 kHz modulating frequency). The input level was established at the frequency of maximum response of the audio modulating circuit.

- Digital Modulation Through a Data Input Port @ 2.1049(h):

Transmitters employing digital modulation techniques - when modulated by an input signal such that its amplitude and symbol rate represent the maximum rated conditions under which the equipment will be operated. The signal shall be applied through any filter networks, pseudo-random generators or other devices required in normal service. Additionally, the Emission Masks shall be shown for operation with any devices used for modifying the spectrum when such devices are operational at the discretion of the user.

The following EMI Receiver bandwidth shall be used for measurement of Emission Mask/Out-of-Band Emission Measurements:

The spectrum analyzer is set to the as follows

- For 25 kHz Channel Spacing: RBW = 300 Hz
- For 12.5 kHz or 6.25 kHz Channel Spacings: RBW = 100 Hz
- The all cases are set "VBW: >3xRBW"

5.4.4 Test setup

Please refer 5.3.4

5.4.5 Measurement Result

Compliance: please refer 5.4.6 for details

5.4.6 Test Plot

■ Analog

CH Low / Low power

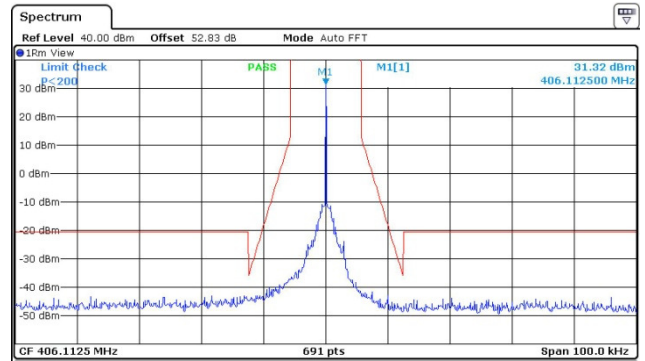
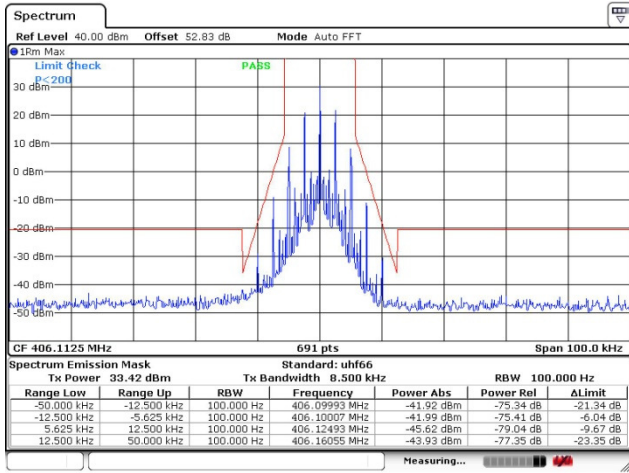

CH Middle / Low power

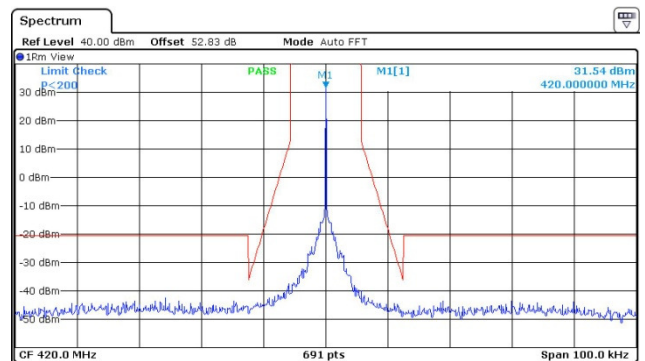
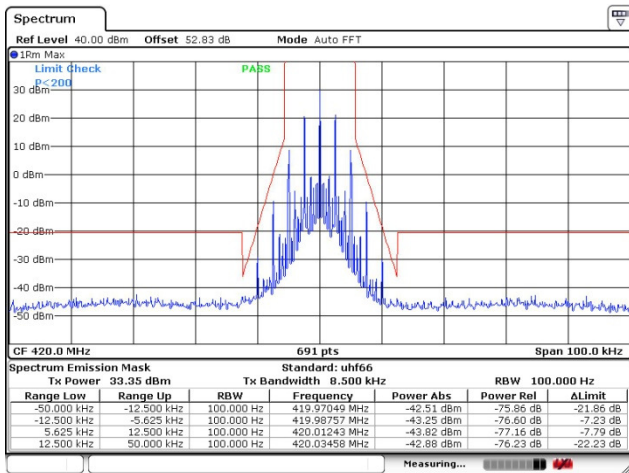

CH High / Low power

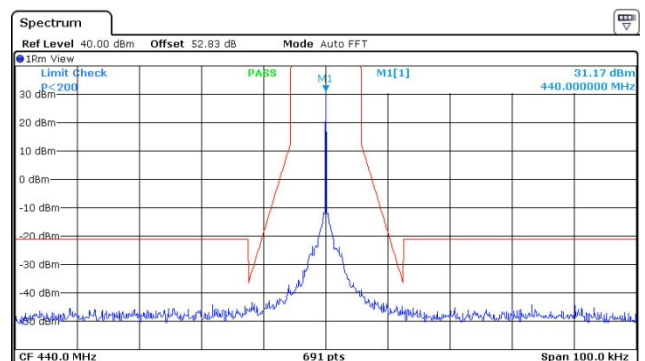
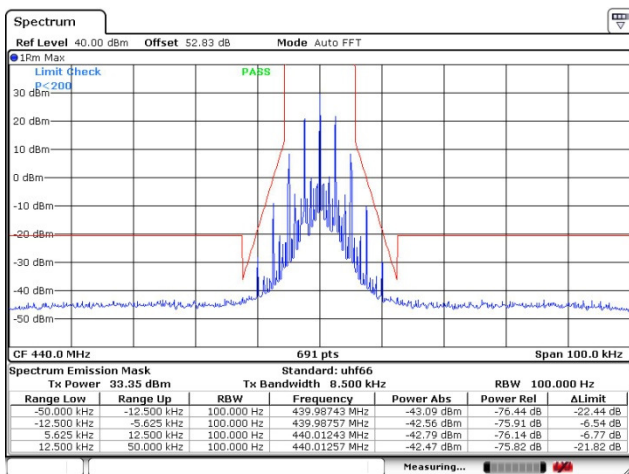

■ Analog

CH Low / High power

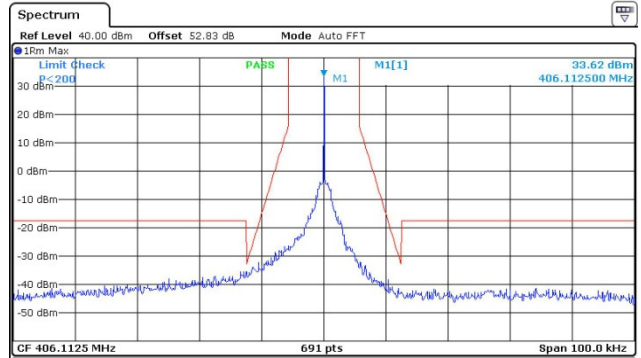
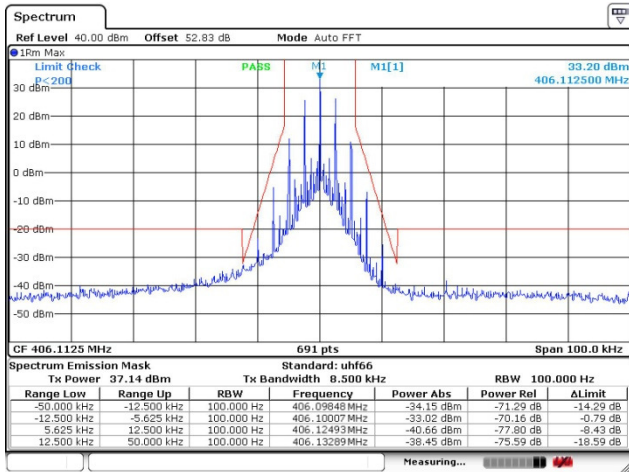

CH Middle / High power

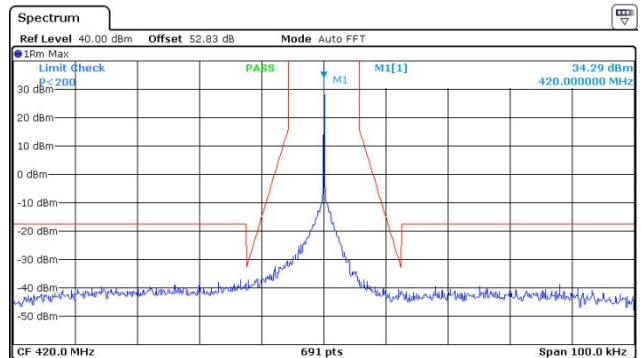
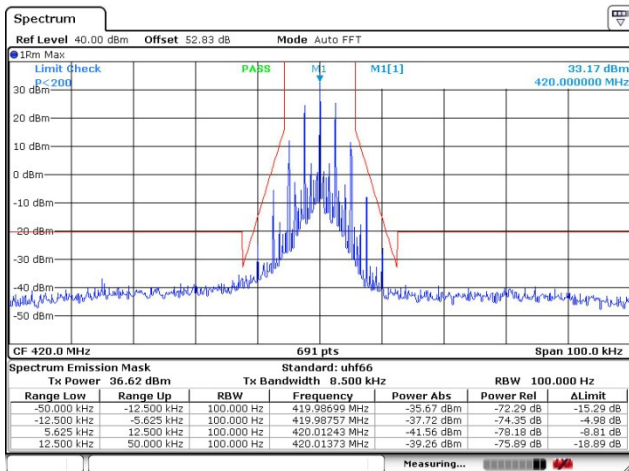

CH High / High power

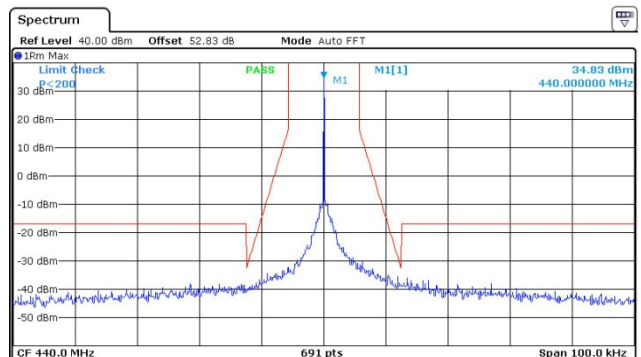
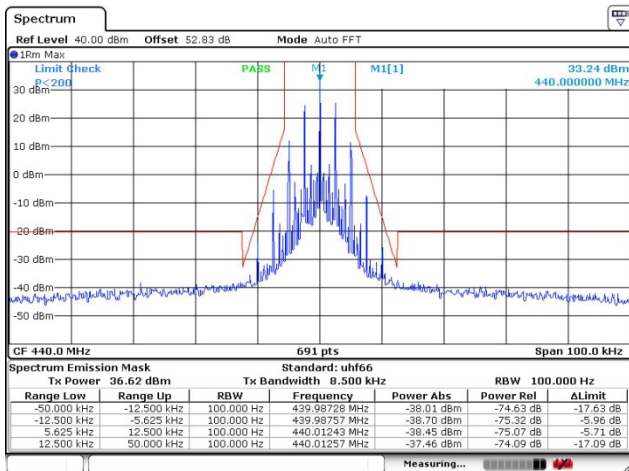

■ Digital (Voice and Data)

CH Low / Low power

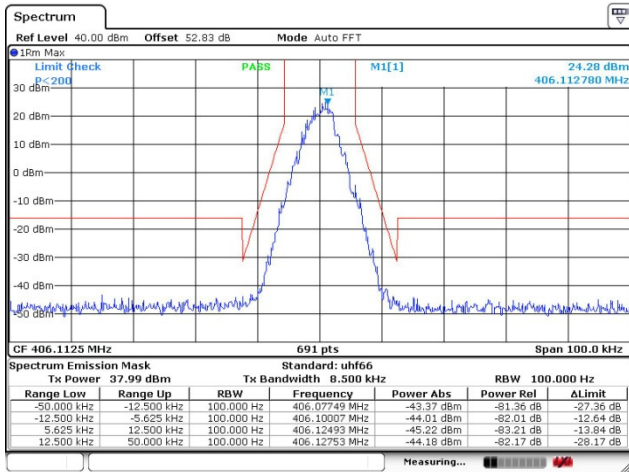

CH Middle / Low power

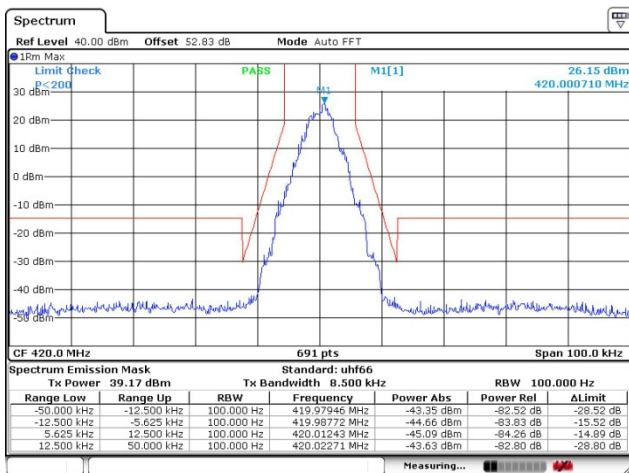

CH High / Low power

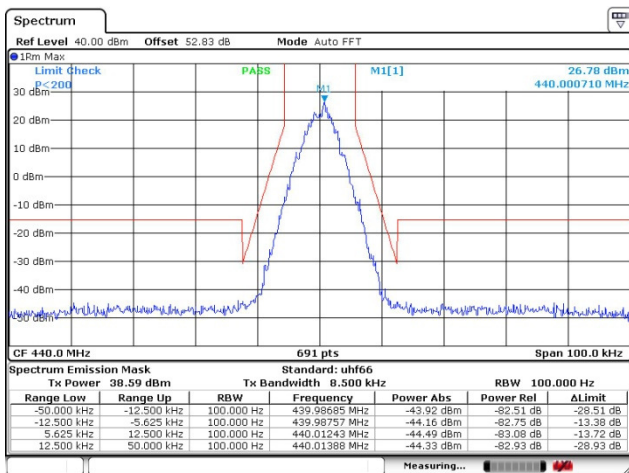

■ Digital (Voice and Data)

CH Low / High power

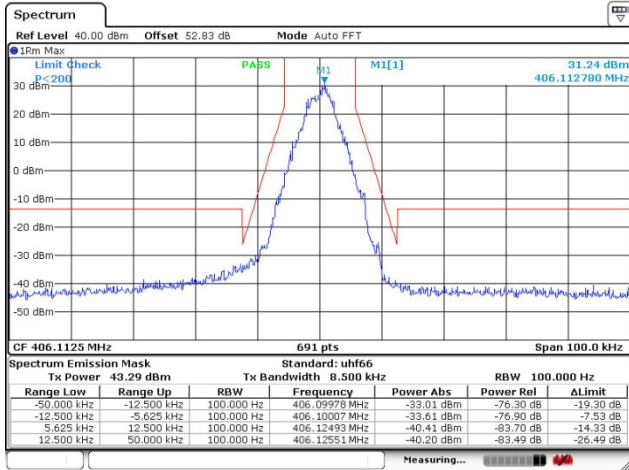

CH Middle / High power

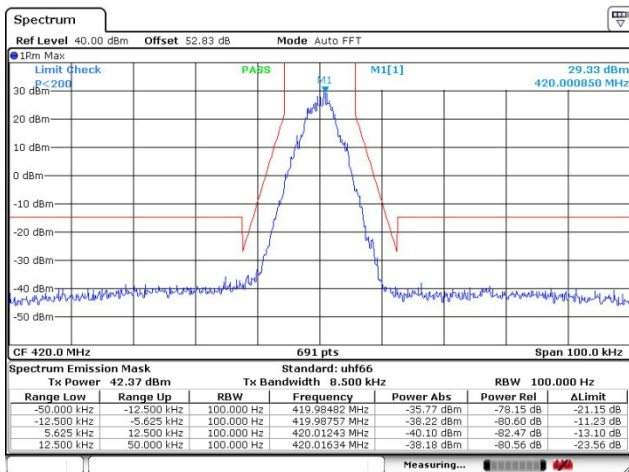

CH High / High power

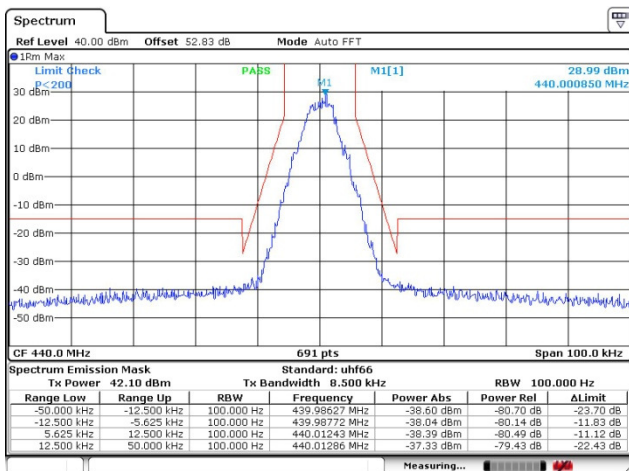

■ The setup table for emission mask

Low power

	Range 1	Range 2	Range 3	Range 4	Range 5
Range Start	-50 kHz	-12.5 kHz	-5.625 kHz	5.625 kHz	12.5 kHz
Range Stop	-12.5 kHz	-5.625 kHz	5.625 kHz	12.5 kHz	50 kHz
Fast SEM	Off	Off	Off	Off	Off
Filter Type	Gaussian	Gaussian	Gaussian	Gaussian	Gaussian
RBW	100 Hz	100 Hz	100 Hz	100 Hz	100 Hz
VBW	300 Hz	300 Hz	300 Hz	300 Hz	300 Hz
Sweep Time Mode	Auto	Auto	Auto	Auto	Auto
Sweep Time	18.962 ms	18.962 ms	18.962 ms	18.962 ms	18.962 ms
Ref. Level	40 dBm	40 dBm	40 dBm	40 dBm	40 dBm
RF Att. Mode	Auto	Auto	Auto	Auto	Auto
RF Attenuator	3 dB	3 dB	3 dB	3 dB	3 dB
Preamp	Off	Off	Off	Off	Off
Transducer	None	None	None	None	None
Limit Check 1	Relative	Relative	Relative	Relative	Relative
Abs Limit Start 1	-13 dBm	-13 dBm	-13 dBm	-13 dBm	-13 dBm
Abs Limit Stop 1	-13 dBm	-13 dBm	-13 dBm	-13 dBm	-13 dBm
Rel Limit Start 1	-54 dBc	-69.9 dBc	33 dBc	-19.9 dBc	-54 dBc
Rel Limit Stop 1	-54 dBc	-19.9 dBc	33 dBc	-69.9 dBc	-54 dBc

High power

	Range 1	Range 2	Range 3	Range 4	Range 5
Range Start	-50 kHz	-12.5 kHz	-5.625 kHz	5.625 kHz	12.5 kHz
Range Stop	-12.5 kHz	-5.625 kHz	5.625 kHz	12.5 kHz	50 kHz
Fast SEM	Off	Off	Off	Off	Off
Filter Type	Gaussian	Gaussian	Gaussian	Gaussian	Gaussian
RBW	100 Hz	100 Hz	100 Hz	100 Hz	100 Hz
VBW	300 Hz	300 Hz	300 Hz	300 Hz	300 Hz
Sweep Time Mode	Auto	Auto	Auto	Auto	Auto
Sweep Time	18.962 ms	18.962 ms	18.962 ms	18.962 ms	18.962 ms
Ref. Level	40 dBm	40 dBm	40 dBm	40 dBm	40 dBm
RF Att. Mode	Auto	Auto	Auto	Auto	Auto
RF Attenuator	3 dB	3 dB	3 dB	3 dB	3 dB
Preamp	Off	Off	Off	Off	Off
Transducer	None	None	None	None	None
Limit Check 1	Relative	Relative	Relative	Relative	Relative
Abs Limit Start 1	-13 dBm	-13 dBm	-13 dBm	-13 dBm	-13 dBm
Abs Limit Stop 1	-13 dBm	-13 dBm	-13 dBm	-13 dBm	-13 dBm
Rel Limit Start 1	-57 dBc	-69.9 dBc	33 dBc	-19.9 dBc	-57 dBc
Rel Limit Stop 1	-57 dBc	-19.9 dBc	33 dBc	-69.9 dBc	-57 dBc

5.5 Spurious Emission On Antenna Port

5.5.1 Standard Applicable [FCC §90.2109(d)]

Emission Mask D: 12.5 kHz channel bandwidth equipment. For transmitters designed to operate with a 12.5 kHz channel bandwidth, any emission must be attenuated below the power (P) of the highest emission contained within the authorized bandwidth as follows:

- 1) For any frequency removed from the center of the authorized bandwidth f_0 to 5.625 kHz removed from f_0 , 0 dB.
- 2) On any frequency removed from the center of the authorized bandwidth by a displacement frequency (f_d in kHz) of more than 5.626 kHz but no more than 12.5 kHz, at least 7.27 ($f_d - 2.88$ kHz) dB.
- 3) On any frequency removed from the center of the authorized bandwidth by a displacement frequency (f_d in kHz) of more than 12.5 kHz: At least $50 + 10 \log(P)$ dB or 70 dB, whichever is the lesser attenuation.

5.5.2 Test Environment conditions

- Ambient temperature : (20 - 21) °C ,
- Relative Humidity : (43 - 45) % R.H.

5.5.3 Measurement Procedure

The carrier was modulated 100 % using a 2500 Hz tone. The spectrum was scanned from the lowest frequency generated to at least the 10th harmonic of the fundamental. The measurements were made in accordance with standard ANSI/TIA 603-D: 2010. The RBW = 100 kHz, VBW = 300 kHz and the span set to 10.0 MHz and the spectrum was scanned from 30 MHz to the 10th harmonic of the fundamental. Above 1 GHz the resolution bandwidth was 1 MHz and the VBW = 3 MHz and the span to 50 MHz.

5.5.4 Test setup

Refer 5.3.4

5.5.5 Measurement Result

Modulation	Freq [MHz]	Power Level	output power	
			[dBm]	[W]
Analog	406.1125	Low	32.83	1.92

Emission Frequency [MHz]	Level below Carrier [dBc]	Margin [dB]	Limit [dBc]	Test Results
811.5	68.95	15.95	53	Compliance
1 217.3	74.86	21.86	53	Compliance

Modulation	Freq [MHz]	Power Level	output power	
			[dBm]	[W]
Analog	420	Low	32.82	1.91

Emission Frequency [MHz]	Level below Carrier [dBc]	Margin [dB]	Limit [dBc]	Test Results
840.2	76.96	23.96	53	Compliance

Modulation	Freq [MHz]	Power Level	output power	
			[dBm]	[W]
Analog	440	Low	32.50	1.78

Emission Frequency [MHz]	Level below Carrier [dBc]	Margin [dB]	Limit [dBc]	Test Results
878.9	77.33	24.33	53	Compliance

Modulation	Freq [MHz]	Power Level	output power	
			[dBm]	[W]
Analog	406.1125	High	36.25	4.22

Emission Frequency [MHz]	Level below Carrier [dBc]	Margin [dB]	Limit [dBc]	Test Results
811.5	74.00	18.00	56	Compliance
1 217.3	71.38	15.38	56	Compliance

Modulation	Freq [MHz]	Power Level	output power	
			[dBm]	[W]
Analog	420	High	36.87	4.86

Emission Frequency [MHz]	Level below Carrier [dBc]	Margin [dB]	Limit [dBc]	Test Results
840.2	77.18	20.18	57	Compliance
1 261.4	75.87	18.87	57	Compliance

Modulation	Freq [MHz]	Power Level	output power	
			[dBm]	[W]
Analog	440	High	36.97	4.98

Emission Frequency [MHz]	Level below Carrier [dBc]	Margin [dB]	Limit [dBc]	Test Results
878.9	74.40	17.40	57	Compliance
1 321.6	74.51	17.51	57	Compliance

Modulation	Freq [MHz]	Power Level	output power	
			[dBm]	[W]
Digital	406.1125	Low	32.71	1.87

Emission Frequency [MHz]	Level below Carrier [dBc]	Margin [dB]	Limit [dBc]	Test Results
811.5	66.83	13.83	53	Compliance
1 217.3	76.71	23.71	53	Compliance

Modulation	Freq [MHz]	Power Level	output power	
			[dBm]	[W]
Digital	420	Low	32.66	1.85

Emission Frequency [MHz]	Level below Carrier [dBc]	Margin [dB]	Limit [dBc]	Test Results
840.2	75.75	22.75	53	Compliance
1 201.2	78.04	25.04	53	Compliance

Modulation	Freq [MHz]	Power Level	output power	
			[dBm]	[W]
Digital	440	Low	32.46	1.76

Emission Frequency [MHz]	Level below Carrier [dBc]	Margin [dB]	Limit [dBc]	Test Results
878.88	72.57	19.57	53	Compliance
1 201.2	77.60	24.60	53	Compliance

Modulation	Freq [MHz]	Power Level	output power	
			[dBm]	[W]
Digital	406.1125	High	36.69	4.67

Emission Frequency [MHz]	Level below Carrier [dBc]	Margin [dB]	Limit [dBc]	Test Results
811.5	70.50	13.50	57	Compliance
1 217.3	73.32	16.32	57	Compliance

Modulation	Freq [MHz]	Power Level	output power	
			[dBm]	[W]
Digital	420	High	36.67	4.65

Emission Frequency [MHz]	Level below Carrier [dBc]	Margin [dB]	Limit [dBc]	Test Results
840.2	79.68	22.68	57	Compliance
1 261.4	75.50	18.50	57	Compliance

Modulation	Freq [MHz]	Power Level	output power	
			[dBm]	[W]
Digital	440	High	36.81	4.80

Emission Frequency [MHz]	Level below Carrier [dBc]	Margin [dB]	Limit [dBc]	Test Results
878.88	72.81	15.81	57	Compliance
1 321.6	73.18	16.18	57	Compliance

Note: The formula for limit is below;
 $50 + 10 \log(P)$ where, P = EUT's output power in W

5.5.6 Limit

Refer 5.5.1

5.6 Transmitter Radiated Unwanted Emissions

5.6.1 Standard Applicable [FCC §90.210(d) & 2.1053]

The power of any emission outside a licensee's frequency band(s) of operation shall be attenuated below the transmitter power (P) within the licensed band(s) of operation, measured in watts, by at least $[50+10 \log (P)]$ (e.i.r.p. -20 dB m)

5.6.2 Test Environment conditions

- Ambient temperature : (20 - 21) °C,
- Relative Humidity : (43 - 45) % R.H.

5.6.3 Measurement Procedure

The EUT was setup according to ANSI/TIA 603D:2010 for compliance to FCC 47CFR part 90 requirements.

As a below test procedure (①~⑪), The result value of measurement is performed to condition of the below; The EUT will operate in continuous transmission mode during the time necessary to perform the measured of the frequency. Substitution method was performed to determine the actual P_{erp} (or P_{eirp}) emission levels of the EUT.

The following test procedure as below;

The test is performed in a fully pyramidal chamber to determine the accurate frequencies, after maximum emissions level will be checked on a test chamber and measuring distance is 3 m from EUT to test antenna.

- ① The EUT was set on with continuous transmission mode and placed on a 0.8 meter high non-conductive table on the chamber.
- ② The test antenna is used on Bi-Log antenna at above 30 MHz, and used on Horn antenna at 1 GHz and then the measurements are repeated with the test antenna for vertical and horizontal polarization. The output of the test antenna will be connected to a measuring receiver, and it is set to tuned over the required standard measuring frequency range.
- ③ At each frequency at which a relevant spurious component is detected, the test antenna will be raised and lowered through the specified range of heights until an maximum signal level is detected on the measuring receiver.
- ④ The EUT is position x, y, z axis on rotating through 360 degrees in the horizontal plane, until the Max. signal level is detected by the measuring receiver.
- ⑤ The receiver is scanned from requested measuring frequency band and then the maximum meter reading is recorded. The radiated emissions were measured with requested standard specification (detector and resolution bandwidth etc.)
- ⑥ The EUT was then removed and replaced with substitution antenna .The center of the antenna was approximately at the same location as the center of the EUT, and calibrated for the frequency of the spurious component detected.
- ⑦ Signal generator output port connected with substitution antenna input port. If necessary, may use shield cable between signal generator and substitution antenna
- ⑧ The frequency of the calibrated signal generator is set to frequency of the spurious component detected, and the input attenuator setting of the measuring receiver was adjust in order to increase the sensitivity of the measuring receiver, if necessary
- ⑨ The test antenna was raised and lowered through the specified range of heights to ensure that maximum signal is received.
- ⑩ The input signal to the substitution antenna was be adjusted until an equal or a known related level to that detected from the transmitter is obtained on the measuring receiver.
- ⑪ The input signal to the substitution antenna was be recorded as a power level and corrected for any change of input attenuator setting of the measuring receiver

⑫ The measure of P_{erp} (or P_{eirp}) the spurious components is the larger of the two power levels recorded for each spurious component at the input to the substitution antenna, corrected for the gain of the substitution antenna, if necessary.

⑬ It is correction to signal generator's offset value. In this case of P_{erp} (or P_{eirp}) shall calculated as follow as formula ;

- P_{erp} (or P_{eirp}) = Signal generator level (dBm) – Cable loss (dB)

The measurement frequency range from 30 MHz - 10th Harmonic of fundamental was investigated.

5.6.5 Test Setup

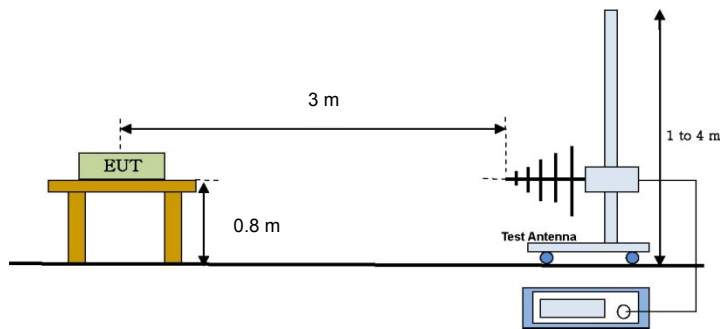

[Radiated measurement setup_Below than 1 GHz]

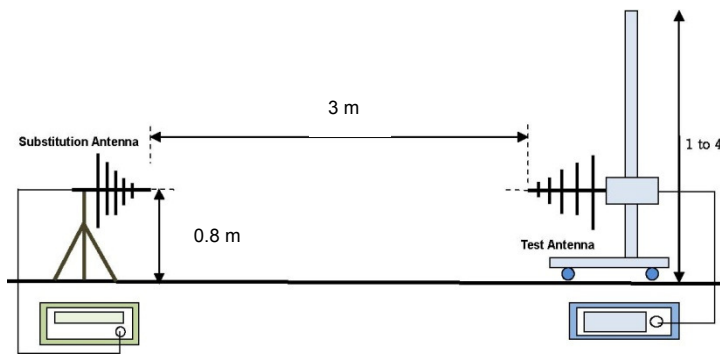

[Effective Radiated Power measurement setup]

※ Above the test antenna is used on Horn antenna at above 1 GHz.

5.6.6 Measurement Result

The following frequencies were selected based on the antenna conducted results, the worst case for each mode are presented.

■ Antenna 1(Main): HW-423W-CT405

Modulation	Freq [MHz]	Power Level	ERP power	
			[dBm]	[W]
Analog	406.1125	Low	32.83	1.92

Emission Frequency [MHz]	Level below Carrier [dBc]	Margin [dB]	Limit [dBc]	Test Results
811.5	70.74	17.74	53	Compliance
1 217.3	77.82	24.82	53	Compliance

Note: The formula for limit is below;
 $50+10 \log (P)$ where, P = EUT's output power in W
 Therefore $50+10\log(1.92) = 53$

Modulation	Freq [MHz]	Power Level	ERP power	
			[dBm]	[W]
Digital	406.1125	High	36.69	4.67

Emission Frequency [MHz]	Level below Carrier [dBc]	Margin [dB]	Limit [dBc]	Test Results
811.5	70.11	13.11	57	Compliance
1 217.3	77.86	20.86	57	Compliance

Note: The formula for limit is below;
 $50+10 \log (P)$ where, P = EUT's output power in W
 Therefore $50+10\log(4.67) = 57$

■ Antenna 2(Optional): HW-423H-CT405

Modulation	Freq [MHz]	Power Level	ERP power	
			[dBm]	[W]
Analog	406.1125	Low	32.83	1.92

Emission Frequency [MHz]	Level below Carrier [dBc]	Margin [dB]	Limit [dBc]	Test Results
811.5	70.30	17.30	53	Compliance
1 217.3	76.46	23.46	53	Compliance

Note: The formula for limit is below;
 $50+10 \log (P)$ where, P = EUT's output power in W
 Therefore $50+10\log(1.92) = 53$

Modulation	Freq [MHz]	Power Level	ERP power	
			[dBm]	[W]
Digital	406.1125	High	36.69	4.67

Emission Frequency [MHz]	Level below Carrier [dBc]	Margin [dB]	Limit [dBc]	Test Results
811.5	69.03	12.03	57	Compliance
1 217.3	75.20	18.20	57	Compliance

Note: The formula for limit is below;
 $50+10 \log (P)$ where, P = EUT's output power in W
 Therefore $50+10\log(4.67) = 57$

5.7 Frequency Stability

5.7.1 Standard Applicable [FCC §90.213 & 2.1055]

The EUT is placed in a temperature chamber, the EUT is allowed to soak at room temperature for 20 minutes and a reference frequency is read. The temperature is then lowered to -30 C and stepped up to 50 C soaking 20 minutes at each temperature then a frequency is read. According to §90.213, the frequency stability limit is 2.5 ppm for 12.5 kHz channel separation.

5.7.2 Test Environment conditions

- Ambient temperature : (20 - 21) °C
- Relative Humidity : (43 - 45) % R.H.

5.6.3 Measurement Procedure

EUT connect to Spectrum analyzer, test is performed in T&H chamber.

These measurements shall also be performed at normal and extreme test conditions.

- Test Method : ANSI/TIA-603-D-2010, clause 3.2.2 for frequency stability tests
 - Frequency stability with respect to ambient temperature
 - Frequency stability when varying supply voltage

5.7.4 Test setup

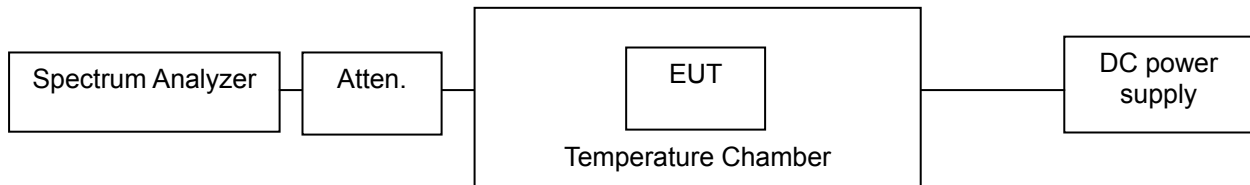

5.7.5 Measurement Result

Analog

Temp(°C)	Power Supply	Measured Freq(MHz)	Freq Drift(ppm)
50	DC 7.4 (Vnom)	420.000024	0.06
40	DC 7.4 (Vnom)	420.000018	0.04
30	DC 7.4 (Vnom)	420.000015	0.04
20	DC 7.4 (Vnom)	420.000012	0.03
10	DC 7.4 (Vnom)	420.000008	0.02
0	DC 7.4 (Vnom)	420.000007	0.02
-10	DC 7.4 (Vnom)	420.000010	0.02
-20	DC 7.4 (Vnom)	420.000008	0.02
-30	DC 7.4 (Vnom)	420.000011	0.03
Nom Temperature	DC 6.3 (Vmin)	420.000020	0.05
Nom Temperature	DC 8.5 (Vmax)	420.000013	0.03

Digital (Voice and Data)

Temp(°C)	Power Supply	Measured Freq(MHz)	Freq Drift(ppm)
50	DC 7.4 (Vnom)	420.000047	0.11
40	DC 7.4 (Vnom)	420.000038	0.09
30	DC 7.4 (Vnom)	420.000035	0.08
20	DC 7.4 (Vnom)	420.000025	0.06
10	DC 7.4 (Vnom)	420.000025	0.06
0	DC 7.4 (Vnom)	420.000019	0.05
-10	DC 7.4 (Vnom)	420.000022	0.05
-20	DC 7.4 (Vnom)	420.000019	0.05
-30	DC 7.4 (Vnom)	420.000020	0.05
Nom Temperature	DC 6.3 (Vmin)	420.000038	0.09
Nom Temperature	DC 8.5 (Vmax)	420.000029	0.07

5.8 Transmitter Frequency Behavior

5.8.1 Standard Applicable [FCC §90.214]

Transient frequencies must be within the maximum frequency difference limits during the time intervals indicated:

Time Intervals	Maximum frequency difference	All equipment (421 to 512 MHz)
Transient Frequency Behavior for Equipment Designed to operate on the 12.5 kHz Channels		
t ₁ ⁴	± 12.5 kHz	10 ms
t ₂	± 6.25 kHz	25 ms
t ₃ ⁴	± 12.5 kHz	10 ms

5.8.2 Test Environment conditions

- Ambient temperature : (20 - 21) °C • Relative Humidity : (43 - 45) % R.H.

5.8.3 Measurement Procedure

- Connect the EUT and test equipment as shown on the following test setup diagram.
- Set the Spectrum Analyzer to measure FM deviation, and tune the RF frequency to the transmitter assigned frequency.
- Set the signal generator to the assigned transmitter frequency and modulate it with a 1 kHz tone at ±12.5 kHz deviation and set its output level to -100 dBm.
- Turn on the transmitter.
- Supply sufficient attenuation via the RF attenuator to provide an input level to the Spectrum Analyzer that is 40 dB below the maximum allowed input power when the transmitter is operating at its rated power level. Note this power level on the Spectrum Analyzer as P₀.
- Turn off the transmitter.
- Adjust the RF level of the signal generator to provide RF power equal to P₀. This signal generator RF level shall be maintained throughout the rest of the measurement.
- Remove the attenuation 1, so the input power to the Spectrum Analyzer is increased by 30 dB when the transmitter is turned on.
- Adjust the vertical amplitude control of the spectrum analyzer to display the 1000 Hz at ±4 divisions vertically centered on the display. Set trigger mode of the Spectrum Analyzer to "Video", and tune the "trigger level" on suitable level. Then set the "trigger offset" to -10ms for turn on and -15 ms for turn off.
- Turn on the transmitter and the transient wave will be captured on the screen of Spectrum Analyzer. Observe the stored display. The instant when the 1 kHz test signal is completely suppressed is considered to be ton. The trace should be maintained within the allowed divisions during the period t₁ and t₂.

5.8.4 Test setup

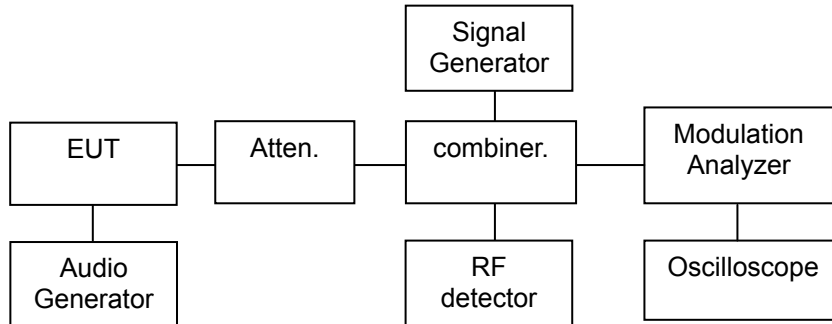

5.8.5 Measurement Result

OFF - ON

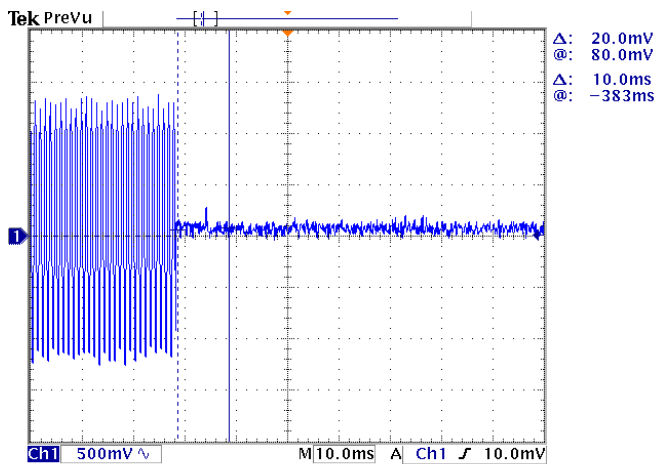

ON - OFF

