

TEST REPORT



KOSTEC Co., Ltd. 28(175-20, Annyeong-dong) 406-gil sejaro, Hwaseong-si, Gyeonggi-do, Korea Tel:031-222-4251, Fax:031-222-4252	Report No.: KST-FCR-180008(1)	 KOSTEC Co., Ltd. http://www.kostec.org
<p>1. Applicant</p> <ul style="list-style-type: none">• Name : SamYoungCeletra. Co.,Ltd.• Address : 110, Geomdan-ro, Seo-gu, Incheon, South Korea <p>2. Test Item</p> <ul style="list-style-type: none">• Product Name: DMR Data/Voice MODEM module• Model Name: CM405• Brand: None• FCC ID: 2AJRJ-CM405 <p>3. Manufacturer</p> <ul style="list-style-type: none">• Name : SamYoungCeletra. Co.,Ltd.• Address : 110, Geomdan-ro, Seo-gu, Incheon, South Korea <p>4. Date of Test : 2018. 02. 12. ~ 2018. 02. 14.</p> <p>5. Test Method Used : FCC CFR 47, Part 90, ANSI/TIA-603-E-2016</p> <p>6. Test Result : Compliance</p> <p>7. Note: Request for family model name by applicant. Family model name: ECOS-D MT100</p>		
<p>Supplementary Information</p> <p>The device bearing the brand name and FCC ID specified above has been shown to comply with the applicable technical standards as indicated in the measurement report and was tested in accordance with measurement procedures specified in ANSI/TIA-603-E-2016</p> <p>We attest to the accuracy of data and all measurements reported herein were performed by KOSTEC Co., Ltd. and were made under Chief Engineer's supervision. We assume full responsibility for the completeness of these measurements and vouch for the qualifications of all persons taking them.</p>		
<p>The results shown in this test report refer only to the sample(s) tested unless otherwise stated.</p>		
Affirmation	Tested by Name : Lee, Mi-Young  (Signature)	Technical Manager Name : Park, Gyeong-Hyeon  (Signature)
<p>2018. 05. 24.</p>		
<p>KOSTEC Co., Ltd.</p>		



Table of Contents

1. GENERAL INFORMATION	3
1.1 Test Facility	3
1.2 Location	3
1.3 Revision History of test report	4
2. EQUIPMENT DESCRIPTION	5
3. SYSTEM CONFIGURATION FOR TEST	6
3.1 Characteristics of equipment	6
3.2 Used peripherals list	6
3.3 Product Modification	6
3.4 Operating Mode	6
3.5 Test Setup of EUT	6
3.6 Table for Carrier Frequencies	7
3.7 Antenna requirement	7
3.8 Used Test Equipment List	8
4. SUMMARY TEST RESULTS	10
5. MEASUREMENT RESULTS	11
5.1 RF Output Power	11
5.2 Modulation Characteristics	12
5.3 Occupied Bandwidth & 26 dB Bandwidth	15
5.4 Emission Mask	24
5.5 Spurious Emission On Antenna Port	27
5.6 Transmitter Radiated Unwanted Emissions	31
5.7 Frequency Stability	34
5.8 Transmitter Frequency Behavior	36

1. GENERAL INFORMATION

1.1 Test Facility

Test laboratory and address

KOSTEC Co., Ltd.

128(175-20,Annyeong-dong)406-gil sejaro, Hwaseong-si Gyeonggi-do, Korea

Registration information

KOLAS No. : 232

FCC Designation No. : KR0041

IC Registration Site No. : 8305A

1.2 Location

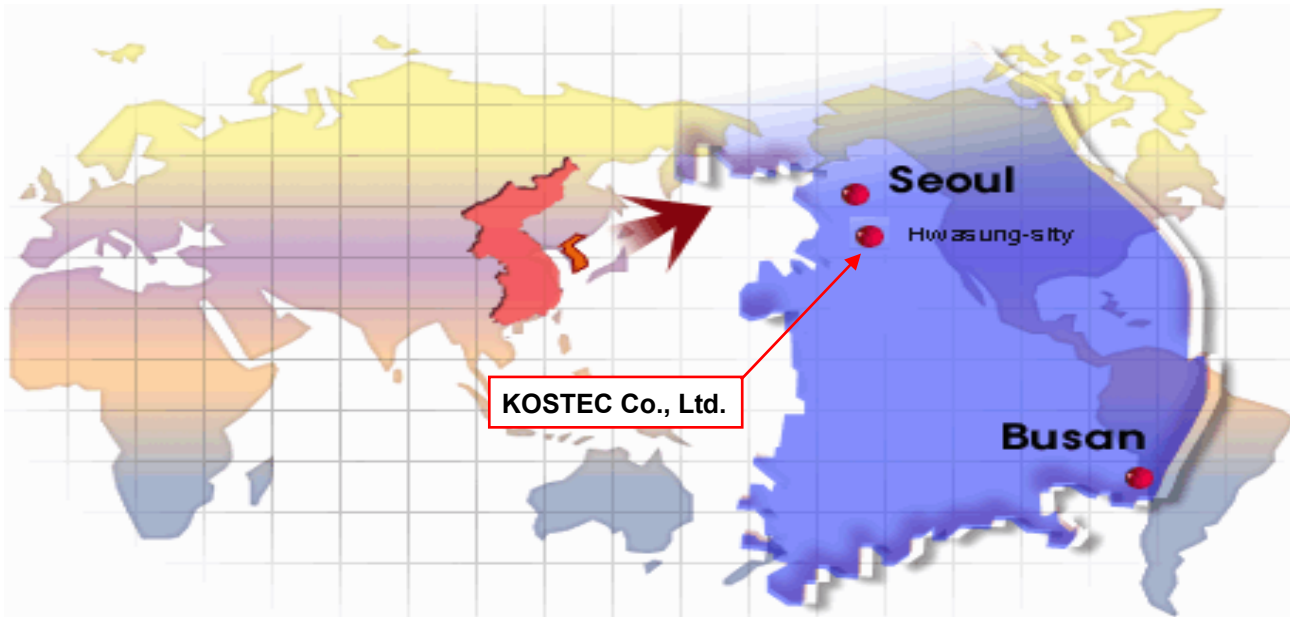

1.3 Revision History of test report

Rev.	Revisions	Effect page	Reviewed	Date
-	Initial issue	All	Gyeong Hyeon, Park	2018. 02. 27.
1	Add section 3.7 and revise product name	1, 5, 7	Gyeong Hyeon, Park	2018. 05. 24.

2. EQUIPMENT DESCRIPTION

The product specification described herein was declared by manufacturer. And refer to user's manual for the details.

Equipment Name	DMR Data/Voice MODEM module
Model No	CM405 (Family model name: ECOS-D MT100)
Type of Equipment	Licensed Non-Broadcast station Transmitter
Intended Operating Environment	General Population/Uncontrolled Exposure
Serial Number	Prototype
Primary User Functions of EUT	2-Way Wireless Voice & Data Communication modem
RF Output Power Rating	5 Watt (High) / 1 Watt (Low)
Assigned Frequency Range	400 ~ 470 MHz
Operating Frequency Range	400.025 ~ 469.975 MHz (406 - 406.1 MHz band is not used.)
RF Output Impedance	50 Ω
Channel Spacing	12.5 kHz
Modulation	FM for analog voice 4FSK for digital Voice and data
Occupied Bandwidth (99%)	5.64 kHz (for 12.5 kHz Channel Spacing / Analog) 7.95 kHz (for 12.5 kHz Channel Spacing / Digital)
Emission Designation	5K64F3E, 7K95F1D, 7K95F1E
Power Source	7.4 Vdc
Antenna Description	HW-423W-CM405R Whip antenna, max 1.624 dBi
FCC ID	2AJRJ-CM405
Remark	The above DUT's information was declared by manufacturer. Please refer to the specifications or user manual for more detailed description.

3. SYSTEM CONFIGURATION FOR TEST

3.1 Characteristics of equipment

The Equipment Under Test (EUT) use for DMR Data/Voice MODEM module.

3.2 Used peripherals list

Description	Model No.	Serial No.	Manufacture	Remark

3.3 Product Modification

N/A

3.4 Operating Mode

Constantly transmitting with a modulated carrier at maximum power on the low, middle and high channels. Radiated emissions tests were performed with antenna ports terminated.

3.5 Test Setup of EUT

The measurements were taken in continuous transmit mode.

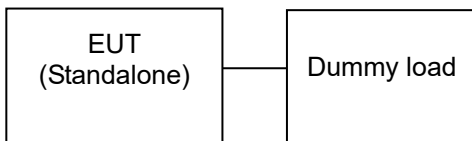

3.6 Table for Carrier Frequencies

Modulation Type	Tested Channel	Channel separation (kHz)	Test freq. (MHz)
Analog	Low	12.5	400.025
	Mid		435.000
	High		469.975
Digital	Low	12.5	400.025
	Mid		435.000
	High		469.975

3.7 Antenna requirement

For intentional device, according to §15.203, an intentional radiator shall be designed to ensure that no antenna other than furnished by responsible party shall be used with the device.

The use of a permanently attached antenna or of an antenna that user a unique coupling to the intentional radiator shall be considered sufficient to comply with the provisions of this section.

The manufacturer may design the unit so that broken antenna can be replaced by the user, but the use of a standard antenna jack or electrical connector is prohibited.

Frequency Band	Connector type	Antenna Type	Gain [dBi]	Results
400 ~ 470 MHz	RP-SMA female	Whip antenna	1.624	Compliance

(Connector type)



(Antenna type)



3.8 Used Test Equipment List

No.	Instrument	Model	S/N	Manufacturer	Due to cal date	Cal interval	used
1	T & H Chamber	EY-101	90E14260	TABAI ESPEC	2018.09.06	1 year	<input type="checkbox"/>
2	T & H Chamber	RCT-V-THC-403-1(H)	20030210	R.C.T	2018.09.06	1 year	<input type="checkbox"/>
3	T & H Chamber	SH-641	92006831	ESPEC CORP	2019.02.14	1 year	<input checked="" type="checkbox"/>
4	Spectrum Analyzer	8593E	3710A02859	Agilent Technology	2019.02.01	1 year	<input type="checkbox"/>
5	Spectrum Analyzer	8563EC	3046A00527	Agilent Technology	2019.02.01	1 year	<input type="checkbox"/>
6	Signal Analyzer	FSV13	101247	Rohde & Schwarz	2019.02.01	1 year	<input type="checkbox"/>
7	Spectrum Analyzer	FSV30	20-353063	Rohde & Schwarz	2019.02.01	1 year	<input checked="" type="checkbox"/>
8	Signal Analyzer	N9010A	MY56070441	Agilent Technologies	2018.05.15	1 year	<input type="checkbox"/>
9	EMI Test Receiver	ESCI7	100823	Rohde & Schwarz	2019.01.29	1 year	<input checked="" type="checkbox"/>
10	EMI Test Receiver	ESI	837514/004	Rohde & Schwarz	2018.09.05	1 year	<input checked="" type="checkbox"/>
11	Vector Signal Analyzer	89441A	3416A02620	Agilent Technology	2019.02.01	1 year	<input type="checkbox"/>
12	Network Analyzer	8753ES	US39172348	AGILENT	2018.09.04	1 year	<input type="checkbox"/>
13	EPM Series Power meter	E4418B	GB39512547	Agilent Technology	2019.01.31	1 year	<input checked="" type="checkbox"/>
14	RF Power Sensor	E9300A	MY41496631	Agilent Technology	2019.01.31	1 year	<input checked="" type="checkbox"/>
15	Microwave Frequency Counter	5352B	2908A00480	Agilent Technology	2019.01.30	1 year	<input type="checkbox"/>
16	Audio Analyzer	8903B	3514A16919	Agilent Technology	2019.01.30	1 year	<input checked="" type="checkbox"/>
17	Audio Telephone Analyzer	DD-5601CID	520010281	CREDIX	2019.01.30	1 year	<input type="checkbox"/>
18	Modulation Analyzer	8901A	3041A0576	H.P	2019.01.31	1 year	<input checked="" type="checkbox"/>
19	Digital storage Oscilloscope	TDS3052	B015962	Tektronix	2018.09.04	1 year	<input checked="" type="checkbox"/>
20	ESG-D Series Signal Generator	E4436B	US39260458	Agilent Technology	2019.01.31	1 year	<input checked="" type="checkbox"/>
21	Vector Signal Generator	SMBV100A	257557	Rohde & Schwarz	2019.01.31	1 year	<input type="checkbox"/>
22	Signal Generator	SMB100A	179628	Rohde & Schwarz	2018.05.18	1 year	<input checked="" type="checkbox"/>
23	Tracking Source	85645A	070521-A1	Agilent Technology	2019.02.01	1 year	<input type="checkbox"/>
24	SLIDAC	None	0207-4	Myoung sung Ele.	2019.01.29	1 year	<input type="checkbox"/>
25	DC Power supply	DRP-5030	9028029	Digital Electronic Co.,Ltd	2019.01.29	1 year	<input type="checkbox"/>
26	DC Power supply	6038A	3440A12674	Agilent Technology	2019.01.29	1 year	<input type="checkbox"/>
27	DC Power supply	E3610A	KR24104505	Agilent Technology	2019.01.29	1 year	<input checked="" type="checkbox"/>
28	DC Power supply	UP-3005T	68	Unicon Co.,Ltd	2019.01.29	1 year	<input type="checkbox"/>
29	DC Power Supply	SM 3400-D	114701000117	DELTAELEKTRONIKA	2019.01.29	1 year	<input type="checkbox"/>
30	DC Power supply	6632B	MY43004005	Agilent Technology	2019.01.31	1 year	<input checked="" type="checkbox"/>
31	DC Power Supply	6632B	MY43004137	Agilent Technology	2019.01.31	1 year	<input type="checkbox"/>
32	Termination	1433-3	LM718	WEINSCHEL	2018.07.20	1 year	<input type="checkbox"/>
33	Termination	1432-3	QR946	AEROFLEX/WEINSCHEL	2018.07.20	1 year	<input checked="" type="checkbox"/>
34	Attenuator	24-30-34	BX5630	Aeroflex / Weinschel	2018.12.15	1 year	<input type="checkbox"/>
35	Attenuator	8498A	3318A09485	HP	2019.01.31	1 year	<input type="checkbox"/>
36	Step Attenuator	8494B	3308A32809	HP	2019.01.31	1 year	<input type="checkbox"/>
37	Attenuator	18B50W-20F	64671	INMET	2019.01.31	1 year	<input type="checkbox"/>
38	Attenuator	10 dB	1	Rohde & Schwarz	2018.05.18	1 year	<input type="checkbox"/>
39	Attenuator	10 dB	2	Rohde & Schwarz	2018.05.18	1 year	<input type="checkbox"/>
40	Attenuator	10 dB	3	Rohde & Schwarz	2018.05.18	1 year	<input type="checkbox"/>
41	Attenuator	10 dB	4	Rohde & Schwarz	2018.05.18	1 year	<input type="checkbox"/>
42	Attenuator	54A-10	74564	WEINSCHEL	2018.08.29	1 year	<input type="checkbox"/>
43	Attenuator	56-10	66920	WEINSCHEL	2018.05.18	1 year	<input type="checkbox"/>
44	Attenuator	48-20-11	BV2658	Aeroflex/Weinschel	2018.08.16	1 year	<input checked="" type="checkbox"/>
45	Attenuator	48-30-33-LIM	BL5350	Weinschel Corp.	2018.08.04	1 year	<input checked="" type="checkbox"/>
46	Power divider	11636B	51212	HP	2019.02.01	1 year	<input checked="" type="checkbox"/>
47	3Way Power divider	KPDSU3W	00070365	KMW	2018.09.04	1 year	<input type="checkbox"/>
48	4Way Power divider	70052651	173834	KRYTAR	2019.02.01	1 year	<input type="checkbox"/>
49	3Way Power divider	1580	SQ361	WEINSCHEL	2018.05.18	1 year	<input type="checkbox"/>

No.	Instrument	Model	S/N	Manufacturer	Due to cal date	Cal interval	used
50	OSP	OSP120	101577	Rohde & Schwarz	2018.05.19	1 year	<input type="checkbox"/>
51	White noise audio filter	ST31EQ	101902	SoundTech	2018.09.04	1 year	<input type="checkbox"/>
52	Dual directional coupler	778D	17693	HEWLETT PACKARD	2019.01.31	1 year	<input type="checkbox"/>
53	Dual directional coupler	772D	2839A00924	HEWLETT PACKARD	2019.01.31	1 year	<input type="checkbox"/>
54	Band rejection filter	3TNF-0006	26	DOVER Tech	2019.02.01	1 year	<input type="checkbox"/>
55	Band rejection filter	3TNF-0007	311	DOVER Tech	2019.02.01	1 year	<input type="checkbox"/>
56	Band rejection filter	WTR-BRF2442-84NN	09020001	WAVE TECH Co.,LTD	2019.01.31	1 year	<input type="checkbox"/>
57	Band rejection filter	WRCJV12-5695-5725-5825-5855-50SS	1	Wainwright Instruments GmbH	2018.05.18	1 year	<input type="checkbox"/>
58	Band rejection filter	WRCJV12-5120-5150-5350-5380-40SS	4	Wainwright Instruments GmbH	2018.05.18	1 year	<input type="checkbox"/>
59	Band rejection filter	WRCGV10-2360-2400-2500-2540-50SS	2	Wainwright Instruments GmbH	2018.05.18	1 year	<input type="checkbox"/>
60	Highpass Filter	WHJS1100-10EF	1	WAINWRIGHT	2019.01.31	1 year	<input type="checkbox"/>
61	Highpass Filter	WHJS3000-10EF	1	WAINWRIGHT	2019.01.31	1 year	<input type="checkbox"/>
62	Highpass Filter	WHNX6-5530-7000-26500-40CC	2	Wainwright Instruments GmbH	2018.05.19	1 year	<input type="checkbox"/>
63	Highpass Filter	WHNX6-2370-3000-26500-40CC	4	Wainwright Instruments GmbH	2018.05.19	1 year	<input type="checkbox"/>
64	WideBand Radio Communication Tester	CMW500	102276	Rohde & Schwarz	2019.02.01	1 year	<input type="checkbox"/>
65	Radio Communication Tester	CMU 200	112026	Rohde & Schwarz	2019.01.31	1 year	<input type="checkbox"/>
66	Bluetooth Tester	TC-3000B	3000B6A0166	TESCOM CO., LTD.	2019.01.31	1 year	<input type="checkbox"/>
67	Loop Antenna	6502	9203-0493	EMCO	2019.05.29	2 year	<input type="checkbox"/>
68	BiconiLog Antenna	3142B	1745	EMCO	2018.07.11	2 year	<input checked="" type="checkbox"/>
69	Trilog-Broadband Antenna	VULB 9168	9168-606	SCHWARZBECK	2018.09.09	2 year	<input type="checkbox"/>
70	Horn Antenna	3115	2996	EMCO	2020.02.14	2 year	<input checked="" type="checkbox"/>
71	Horn Antenna	BBHA9170	743	SCHWARZBECK	2019.04.25	2 year	<input type="checkbox"/>
72	Antenna Master(3)	AT13	None	AUDIX	N/A	N/A	<input type="checkbox"/>
73	Turn Table(3)	None	None	AUDIX	N/A	N/A	<input type="checkbox"/>
74	PREAMPLIFIER(3)	8449B	3008A02577	Agilent	2019.02.02	1 year	<input checked="" type="checkbox"/>
75	Antenna Master(10)	MA4000-EP	None	innco systems GmbH	N/A	N/A	<input checked="" type="checkbox"/>
76	Turn Table(10)	None	None	innco systems GmbH	N/A	N/A	<input checked="" type="checkbox"/>
77	AMPLIFIER(10)	TK-PA6S	120009	TESTEK	2019.01.29	1 year	<input checked="" type="checkbox"/>
78	AMPLIFIER	8447D	2944A07881	H.P	2019.01.29	1 year	<input type="checkbox"/>
79	Antenna Mast	MA2000-EP	None	innco systems GmbH	N/A	N/A	<input type="checkbox"/>
80	Turn Device	DE3700-RH	None	innco systems GmbH	N/A	N/A	<input type="checkbox"/>

4. SUMMARY TEST RESULTS

Description of Test	FCC Rule	Reference Clause	Used	Test Result
RF Output Power	Part 90.205	Clause 5.1	<input checked="" type="checkbox"/>	Compliance
Modulation Characteristics	Part 2.1047(a), 90.242(b)(8)	Clause 5.2	<input checked="" type="checkbox"/>	Compliance
Occupied Bandwidth	Part 90.209	Clause 5.3	<input checked="" type="checkbox"/>	Compliance
Emission Mask	Part 90.210	Clause 5.4	<input checked="" type="checkbox"/>	Compliance
Frequency Stability	Part 90.213	Clause 5.5	<input checked="" type="checkbox"/>	Compliance
Spurious Emission On Antenna Port	Part 90.210	Clause 5.6	<input checked="" type="checkbox"/>	Compliance
Transmitter Radiated Unwanted Emissions	Part 90.210	Clause 5.7	<input checked="" type="checkbox"/>	Compliance
Transmitter Frequency Behavior	Part 90.214	Clause 5.8	<input checked="" type="checkbox"/>	Compliance
<p>Compliance/pass : The EUT complies with the essential requirements in the standard. Not Compliance : The EUT does not comply with the essential requirements in the standard. N/A : The test was not applicable in the standard.</p>				

Procedure Reference

FCC CFR 47, Part 90

ANSI/TIA-603-E-2016

5. MEASUREMENT RESULTS

5.1 RF Output Power

5.1.1 Standard Applicable [FCC §90.205 & 2.1046]

Applicants for licenses must request and use no more power than the actual power necessary for satisfactory operation.

The output power shall not exceed by more than 20 percent either the output power shown in the Radio Equipment List for transmitters included in this list or when not so listed, the manufacturer's rated output power for the particular transmitter specifically listed on the authorization.

5.1.2 Test Environment conditions

- Ambient temperature : (20 - 21) °C • Relative Humidity : (47 - 48) % R.H.

5.1.3 Measurement Procedure

The transmitter output was connected to the power meter with an attenuator. The power output shall be monitored and recorded and no adjustment shall be made to the transmitter after the test has begun, except as noted below: If the power output is adjustable, measurements shall be made for the highest and lowest power levels.

5.1.4 Test setup

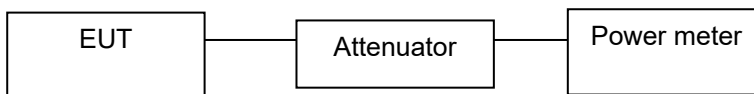

5.1.5 Measurement Result

Modulation	Frequency [MHz]	Power Level	Conducted output Power [dBm]	Conducted output Power [W]	Limit [dBm]	Test Results
Analog	400.025	Low	30.67	1.17	1.6 - 2.4 W	Compliance
	435.000	Low	30.63	1.16		Compliance
	469.975	Low	30.25	1.06		Compliance
	400.025	High	36.83	4.82	4 - 6 W	Compliance
	435.000	High	36.91	4.91		Compliance
	469.975	High	36.43	4.40		Compliance
Digital	400.025	Low	30.72	1.18	1.6 - 2.4 W	Compliance
	435.000	Low	30.75	1.19		Compliance
	469.975	Low	30.65	1.16		Compliance
	400.025	High	37.31	5.38	4 - 6 W	Compliance
	435.000	High	37.34	5.42		Compliance
	469.975	High	36.91	4.91		Compliance

5.2 Modulation Characteristics

5.2.1 Standard Applicable [FCC §Part 2.1047(a)]

2.1047(b): Equipment which employs modulation limiting. A curve or family of curves showing the percentage of modulation versus the modulation input voltage shall be supplied. The information submitted shall be sufficient to show modulation limiting capability throughout the range of modulating frequencies and input modulating signal levels employed.

Recommended frequency deviation characteristics are given below:

CH spacing	Frequency deviation
12.5 kHz	2.5 kHz

Part 2.1047(a) A curve or equivalent data showing the frequency response of the audio modulating circuit over a range of 100 to 5000 Hz shall be submitted. For equipment required to have an audio low-pass filter, a curve showing the frequency response of the filter, or of all circuitry installed between the modulation limiter and the modulated stage shall be submitted.

90.242(b)(8) Recommended audio filter attenuation characteristics are given below:

Audio freq.	Minimum Attenuation Rel. to 1 kHz Attenuation
3 - 20 kHz	60 log ₁₀ (f/3) dB where f is in kHz
20 - 30 kHz	50 dB

5.2.2 Test Environment conditions

- Ambient temperature : (20 - 21) °C • Relative Humidity : (47 - 48) % R.H.

5.2.3 Measurement Procedure

- Modulation Limit

The carrier frequency deviation was measured with the tone adjust the audio input for 60 % of rated system deviation at 1 kHz using this level as a reference (0 dB) and vary the input level from -20 to +20 dB. Record the frequency deviation obtained as a function of the input level at frequencies 0.1, 0.5, 1.0, 3.0 and 5.0 kHz. The maximum deviation was recorded at each test condition.

- Audio frequency response

The audio input level needed for a particular percentage of modulation was measured in accordance with ANSI/TIA 603-D: 2010. The audio input curves versus modulation are shown below. Curves are provided for audio input frequencies of 300, 1000, and 3000 Hz.

- Test freq: Mid

5.2.4 Test setup

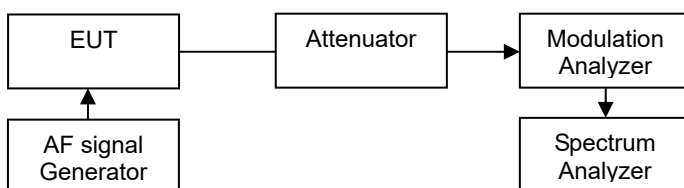

5.2.5 Measurement Result

- Modulation Limit

Audio input Level (dB)	Frequency Deviation (kHz)			Limit (kHz)
	@ 300 Hz	@ 1 kHz	@ 3 kHz	
-20	0.10	0.18	0.34	2.5
-15	0.11	0.29	0.62	2.5
-10	0.14	0.64	1.10	2.5
-5	0.32	0.73	1.79	2.5
0	0.41	1.55	1.85	2.5
5	0.67	1.97	1.91	2.5
10	0.92	2.03	1.92	2.5
15	0.95	2.04	1.92	2.5
20	1.00	2.14	1.93	2.5

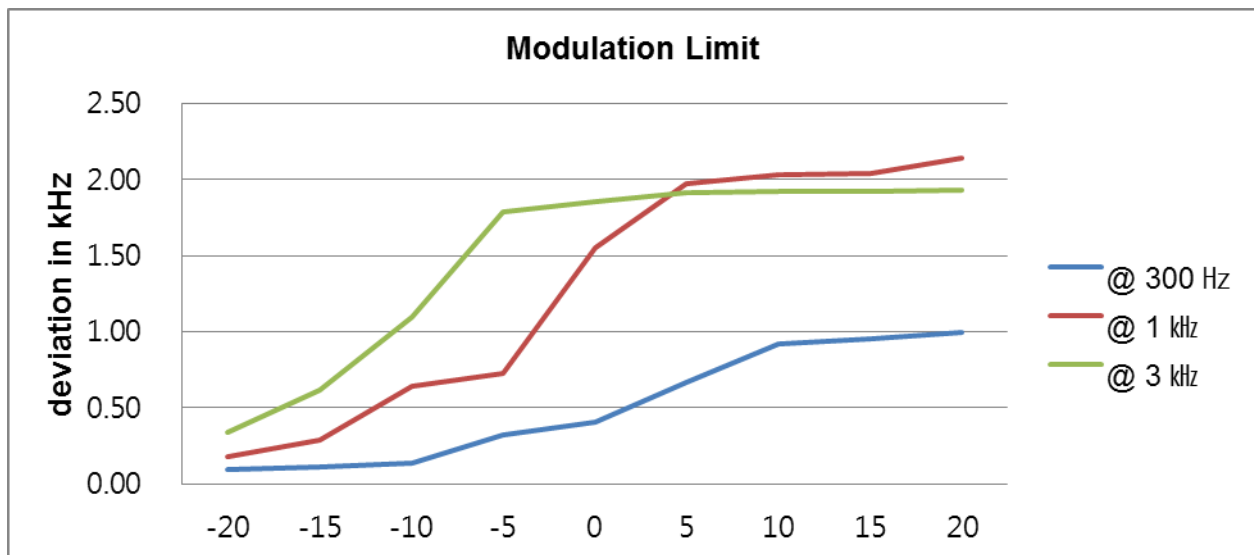

• Audio frequency response

Audio Frequency (Hz)	Response Attenuation (dB)	Audio Frequency (Hz)	Response Attenuation (dB)
300	-11.23	2 800	4.51
400	-8.41	2 900	5.1
500	-6.15	3 000	5.32
600	-4.36	3 100	2.11
700	-2.76	3 200	1.98
800	-1.69	3 300	-5.98
900	-0.75	3 400	-13.52
1 000	-0.03	3 500	-20.21
1 200	1.85	4 000	-45.41
1 400	2.88	5 000	-59.13
1 600	3.21		
1 800	3.25		
2 000	3.29		
2 100	3.38		
2 200	3.41		
2 300	3.42		
2 400	3.46		
2 500	3.65		
2 600	3.99		
2 700	4.29		

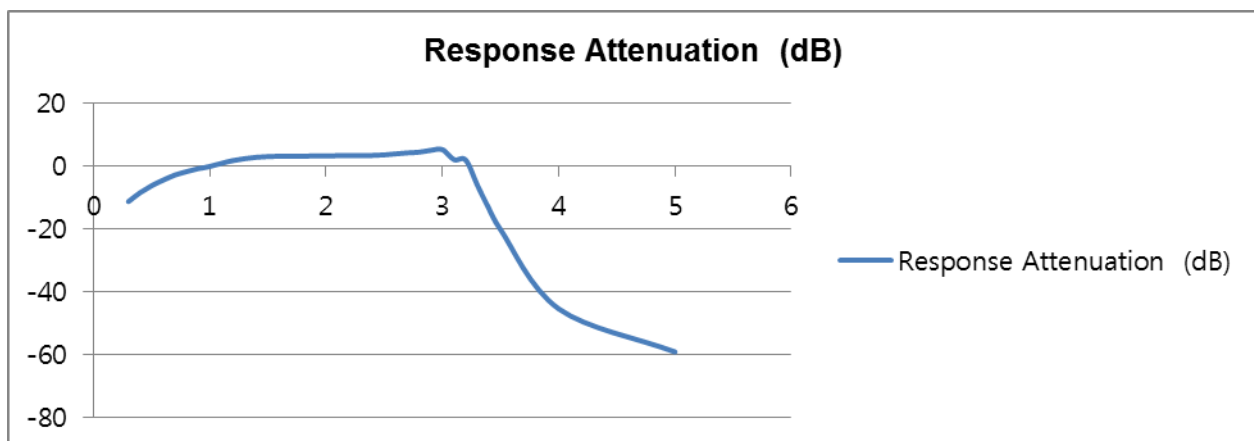

5.3 Occupied Bandwidth & 26 dB Bandwidth

5.3.1 Standard Applicable [FCC §90.209 & 2.1049]

According to FCC Part 90 Section 90.209: The authorized bandwidth shall be 11.25 kHz for 12.5 kHz channel separation and 6 kHz for 6.25 kHz channel separation.

5.3.2 Test Environment conditions

- Ambient temperature : (20 - 21) °C • Relative Humidity : (47 - 48) % R.H.

5.3.3 Measurement Procedure

1. The EUT was modulated by 2.5 kHz Sine wave audio signal, The level of the audio signal employed is 16 dB greater than that necessary to produce 50 % of rated system deviation. Rated system deviation is 2.5 kHz (12.5 kHz channel spacing).
2. The transmitter output (antenna port) was connected to the spectrum analyzer in peak hold mode.
3. Measure the maximum width of the emission that is 26 dB down from the peak of the emission. The 99 % occupied bandwidth is the frequency bandwidth of the signal power at the 99 % channel power of occupied bandwidth.

The spectrum analyzer is set to the as follows :

- RBW : 300 Hz
- VBW : >3 x RBW
- Detector function : peak
- Trace : max hold

5.3.4 Test setup

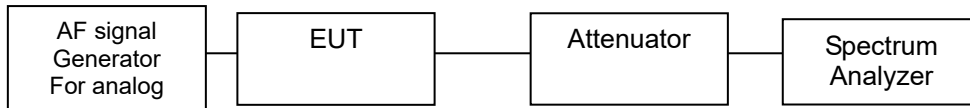

5.3.5 Measurement Result

Modulation	Frequency [MHz]	Power Level	99 % Bandwidth [KHz]	26 dB Bandwidth [kHz]	Limit [kHz]	Test Results
Analog	400.025	Low	5.644	10.116	≤ 11.25	Compliance
	435.000	Low	5.644	10.159		Compliance
	469.975	Low	5.644	10.116		Compliance
	400.025	High	5.644	10.159	≤ 11.25	Compliance
	435.000	High	5.644	10.116		Compliance
	469.975	High	5.644	10.203		Compliance
Digital (Voice and Data)	400.025	Low	7.858	10.159	≤ 11.25	Compliance
	435.000	Low	7.945	10.072		Compliance
	469.975	Low	7.814	10.246		Compliance
	400.025	High	7.685	9.760	≤ 11.25	Compliance
	435.000	High	7.641	9.768		Compliance
	469.975	High	7.641	9.725		Compliance

5.3.6 Test Plot (26 dB band width for analog)

Power level: Low

CH Low

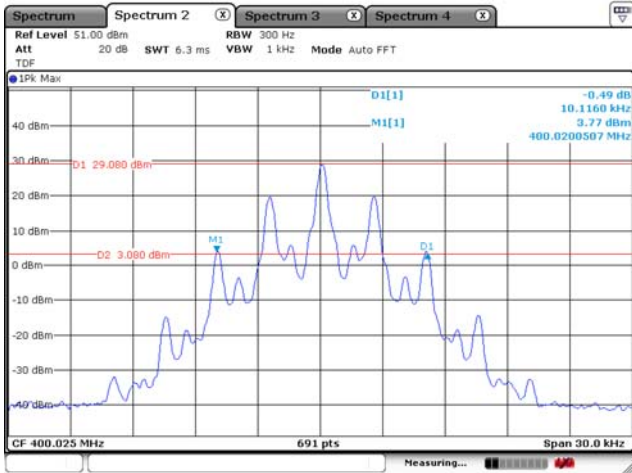

CH Middle

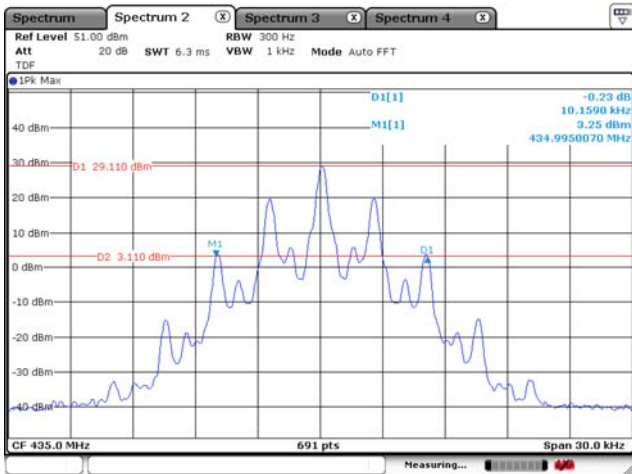

CH High

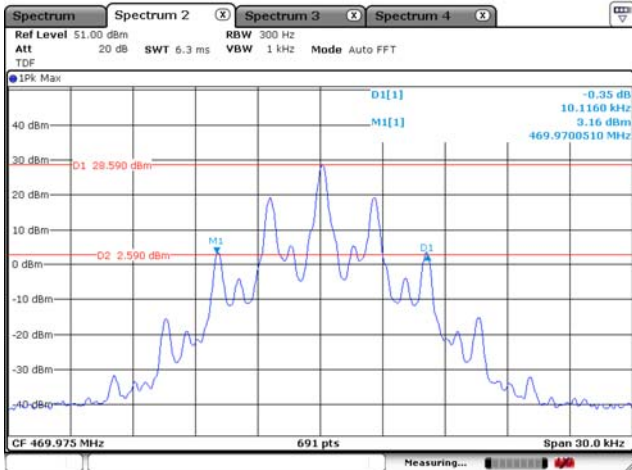

Power level: High

CH Low

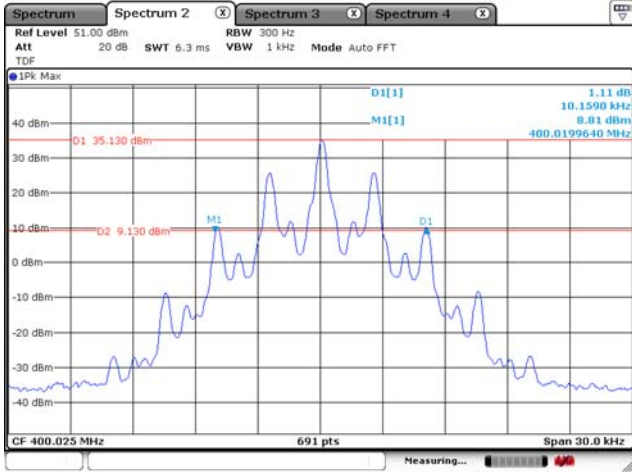

CH Middle

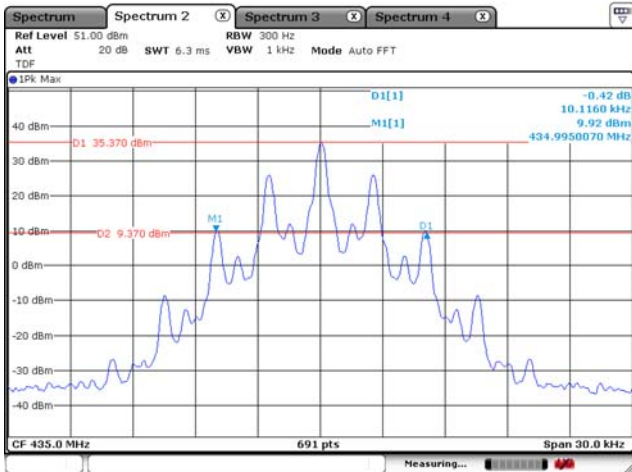

CH High

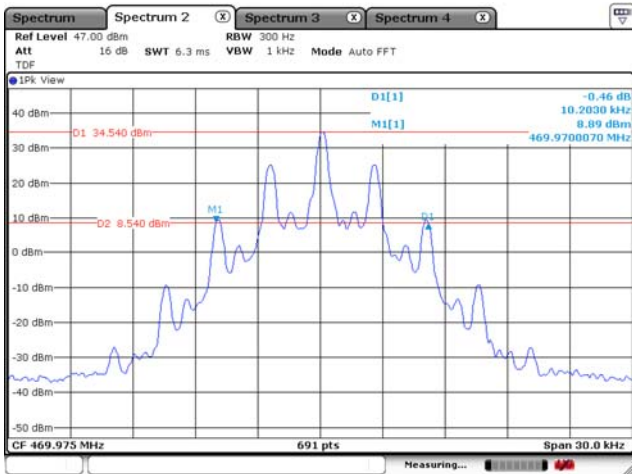

Test Plot (99 % band width for analog)

Power level: Low

CH Low

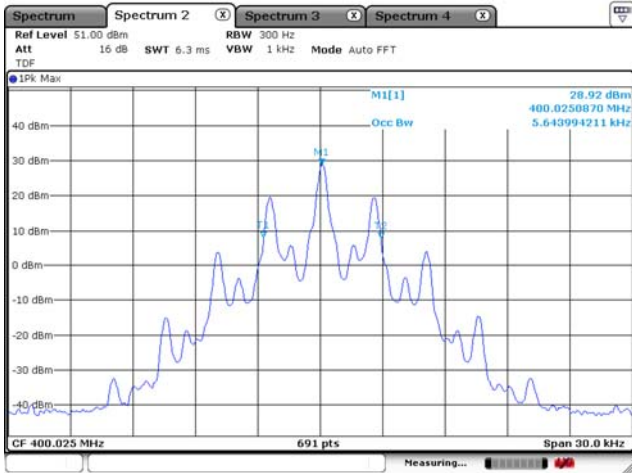

CH Middle

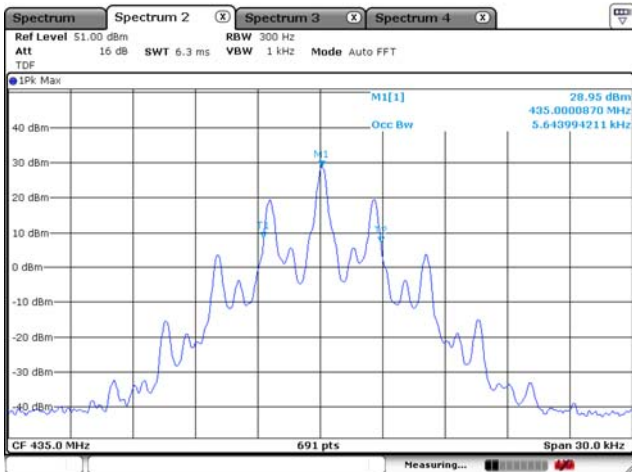

CH High

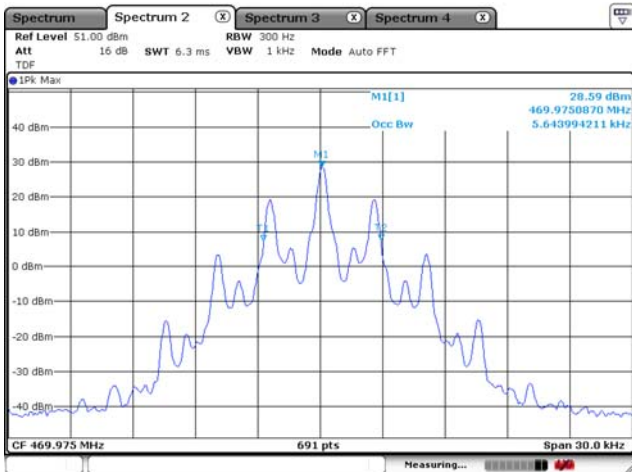

Power level: High

CH Low

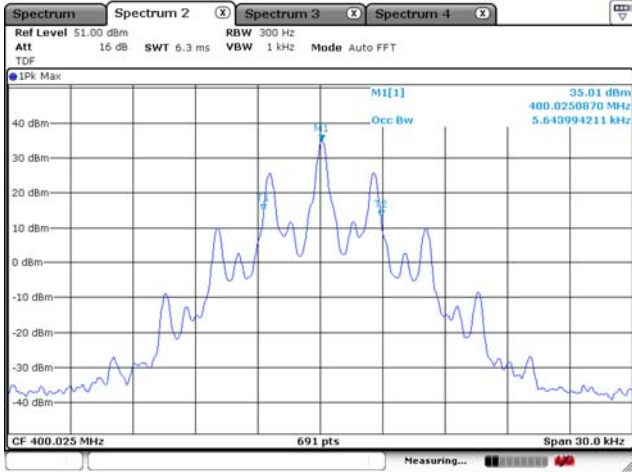

CH Middle

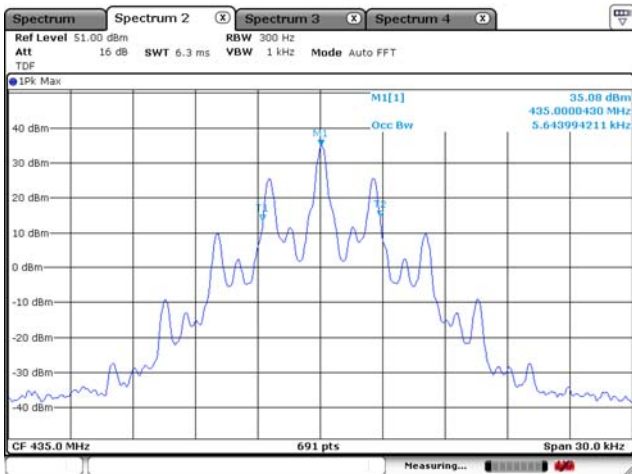

CH High

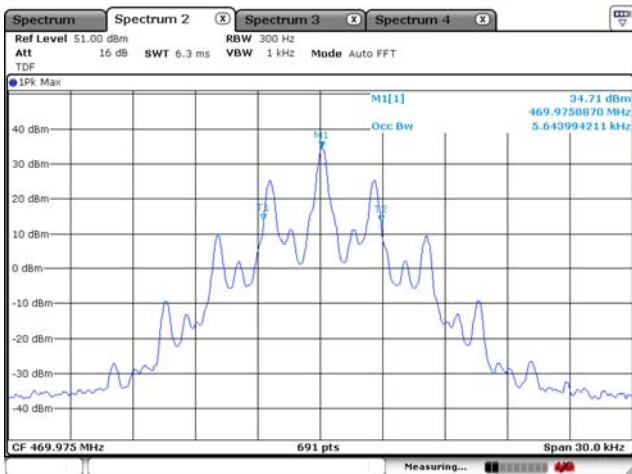

Test Plot (26 dB band width for digital)

Power level: Low

CH Low

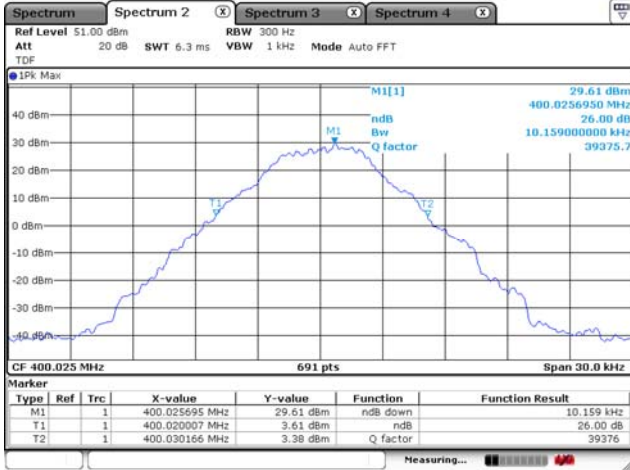

CH Middle

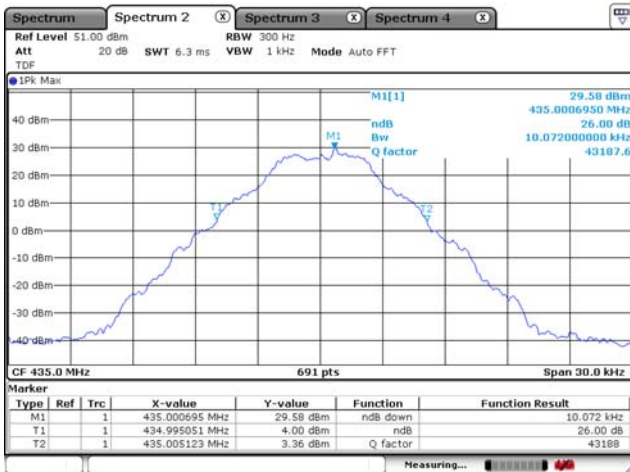

CH High

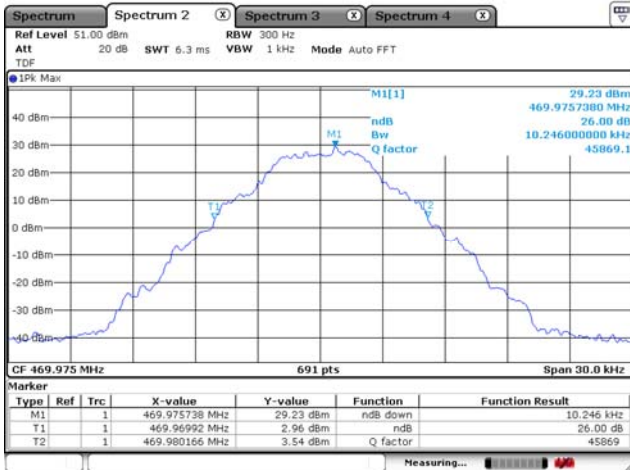

Power level: High

CH Low

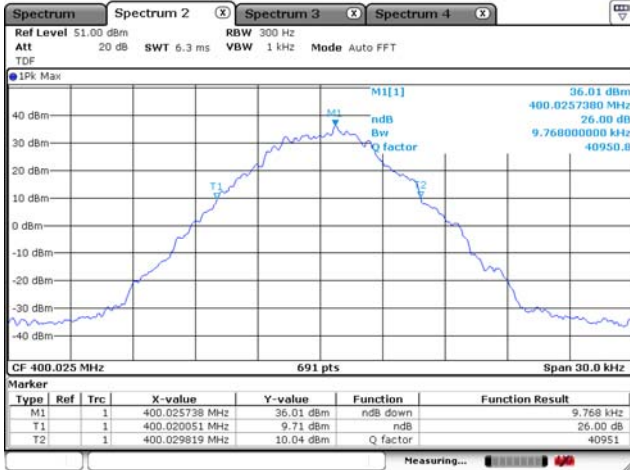

CH Middle

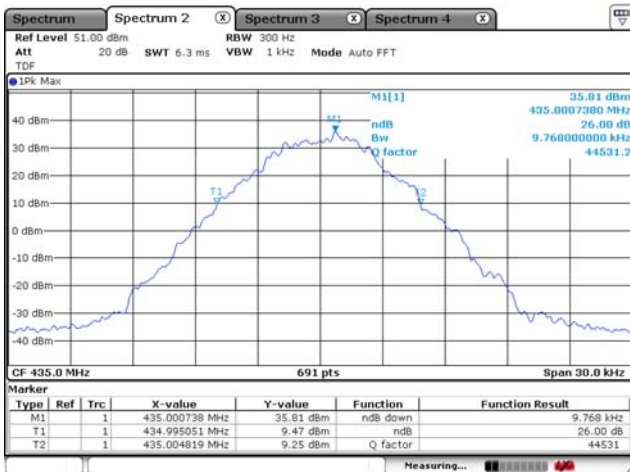

CH High

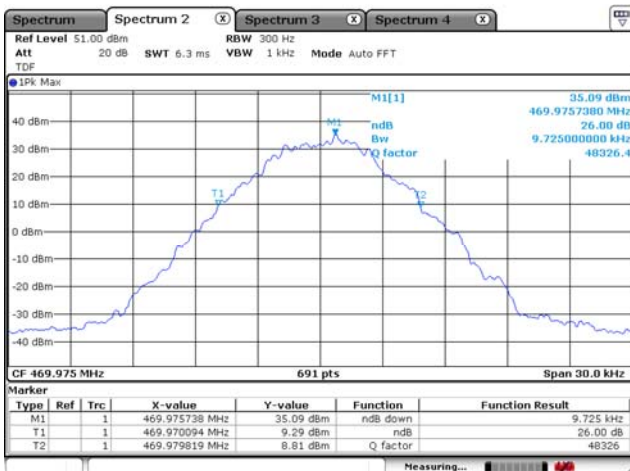

Test Plot (99 % band width for digital)

Power level: Low

CH Low

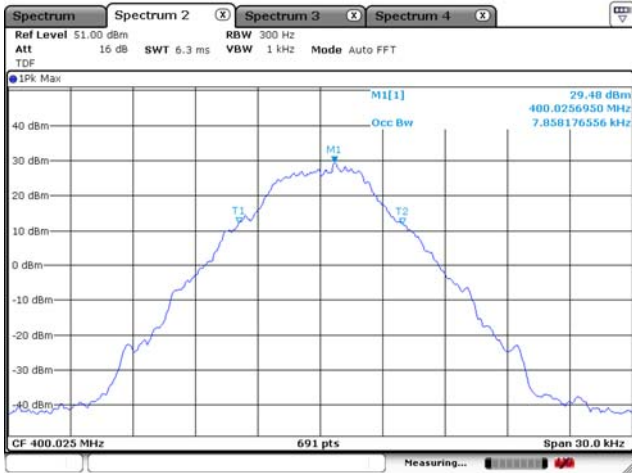

CH Middle

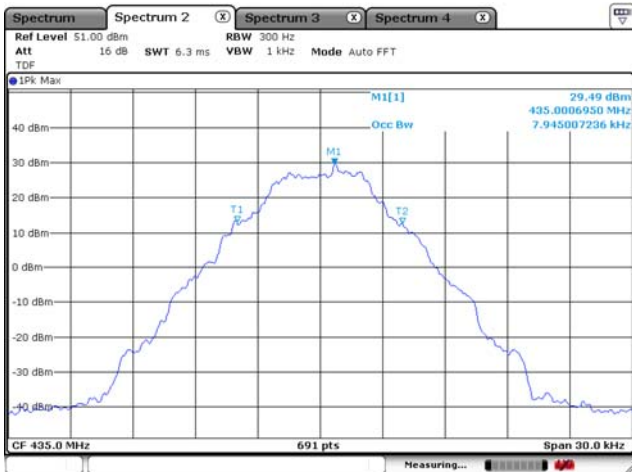

CH High

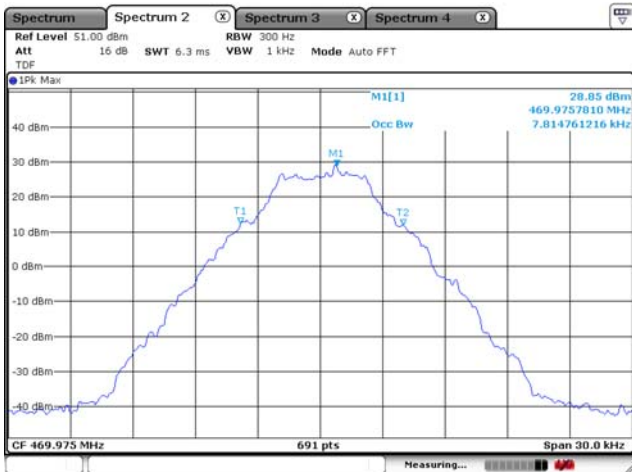

Power level: High

CH Low

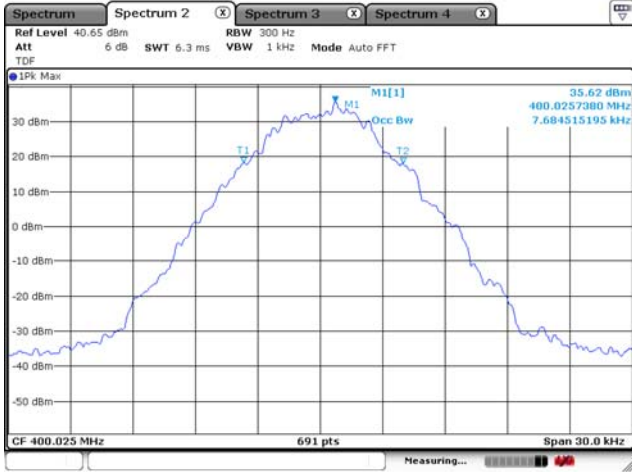

CH Middle

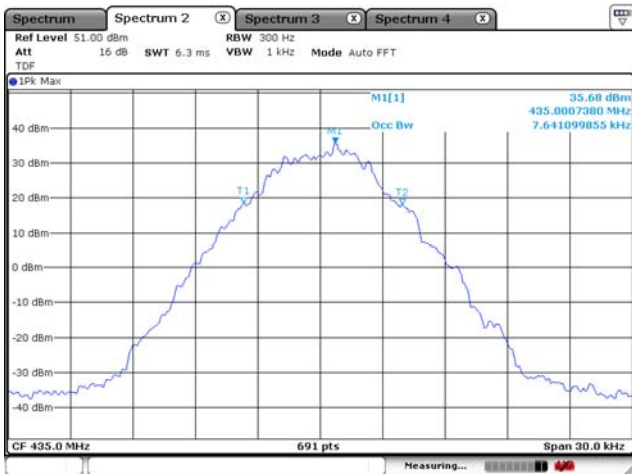

CH High

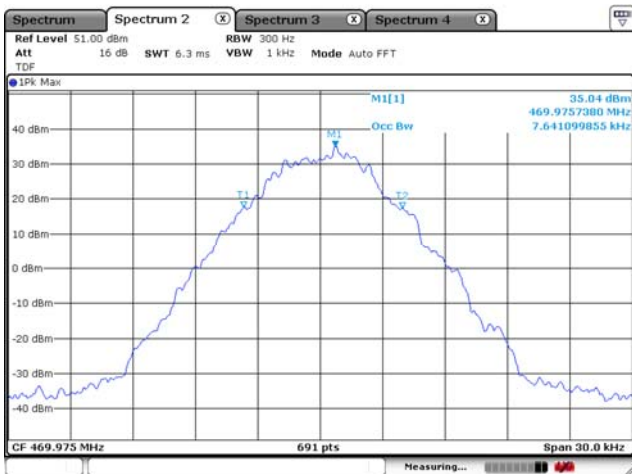

5.4 Emission Mask

5.4.1 Standard Applicable [FCC §90.210]

Emission mask D: For transmitters designed to operate with a 12.5 kHz channel bandwidth, any emission must be attenuated below the power (P) of the highest emission contained within the authorized bandwidth as follows:

- (1) On any frequency from the center of the authorized bandwidth f_0 to 5.625 kHz removed from f_0 : Zero dB.
- (2) On any frequency removed from the center of the authorized bandwidth by a displacement frequency (f_d in kHz) of more than 5.625 kHz but no more than 12.5 kHz: At least $7.27(f_d - 2.88 \text{ kHz})$ dB.
- (3) On any frequency removed from the center of the authorized bandwidth by a displacement frequency (f_d in kHz) of more than 12.5 kHz: At least $50 + 10 \log(P)$ dB or 70 dB, whichever is the lesser attenuation.

5.4.2 Test Environment conditions

- Ambient temperature : (20 - 21) °C • Relative Humidity : (47 - 48) % R.H.

5.4.3 Measurement Procedure

- Voice or Digital Modulation Through a Voice Input Port @ 2.1049(c)(i)

The transmitter was modulated by a 2.5 kHz tone signal at an input level 16 dB greater than that required to produce 50 % modulation (e.g.: ± 2.5 kHz peak deviation at 1 kHz modulating frequency). The input level was established at the frequency of maximum response of the audio modulating circuit.

- Digital Modulation Through a Data Input Port @ 2.1049(h):

Transmitters employing digital modulation techniques - when modulated by an input signal such that its amplitude and symbol rate represent the maximum rated conditions under which the equipment will be operated. The signal shall be applied through any filter networks, pseudo-random generators or other devices required in normal service. Additionally, the Emission Masks shall be shown for operation with any devices used for modifying the spectrum when such devices are operational at the discretion of the user.

The following EMI Receiver bandwidth shall be used for measurement of Emission Mask/Out-of-Band Emission Measurements:

The spectrum analyzer is set to the as follows

- For 25 kHz Channel Spacing: RBW = 300 Hz
- For 12.5 kHz or 6.25 kHz Channel Spacings: RBW = 100 Hz
- The all cases are set "VBW: >3xRBW"

5.4.4 Test setup

Please refer 5.3.4

5.4.5 Measurement Result

Compliance: please refer 5.4.6 for details

5.4.6 Test Plot

■ Analog

CH Low / Low power

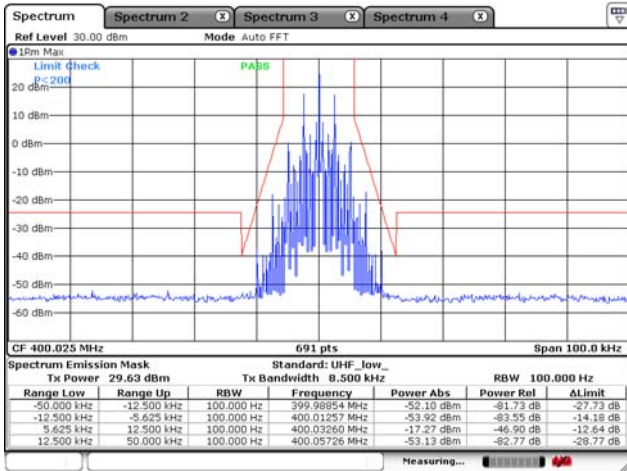

CH Low / High power

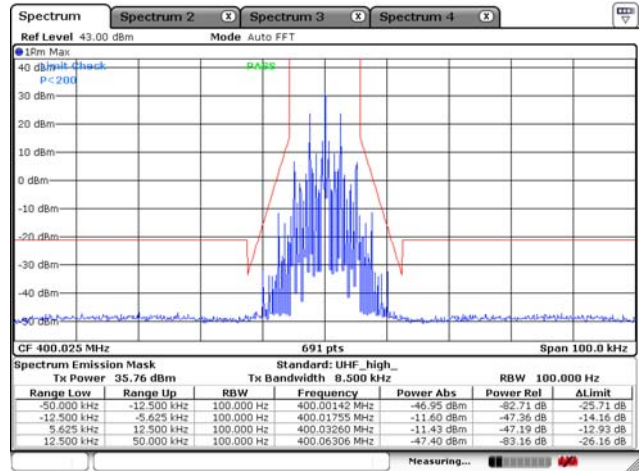

CH Middle / Low power

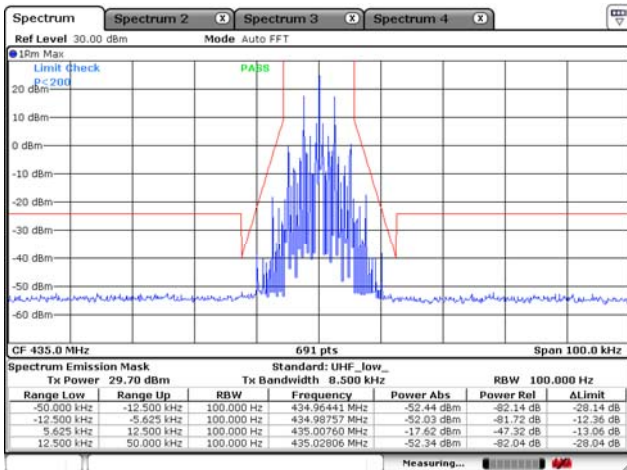

CH Middle / High power

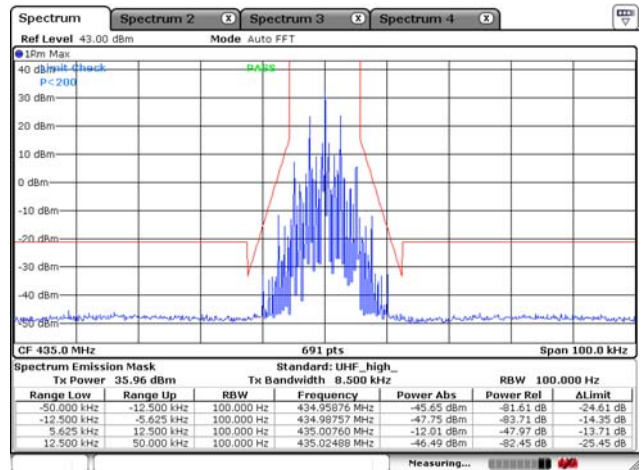

CH High / Low power

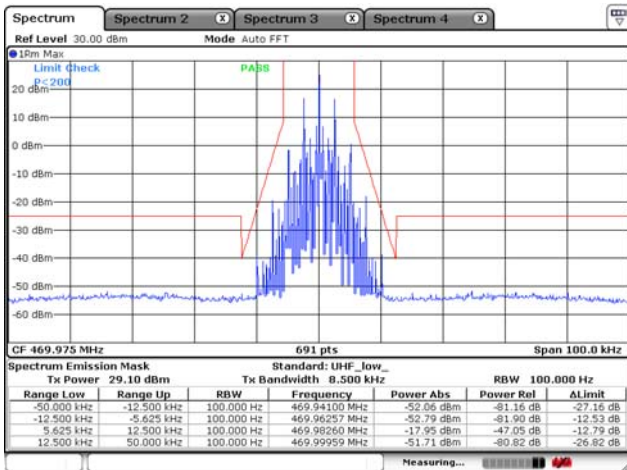

CH High / High power

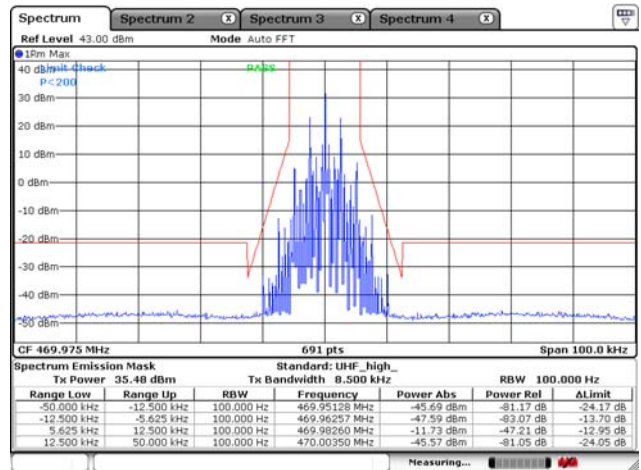

■ Digital (Voice and Data)

CH Low / Low power

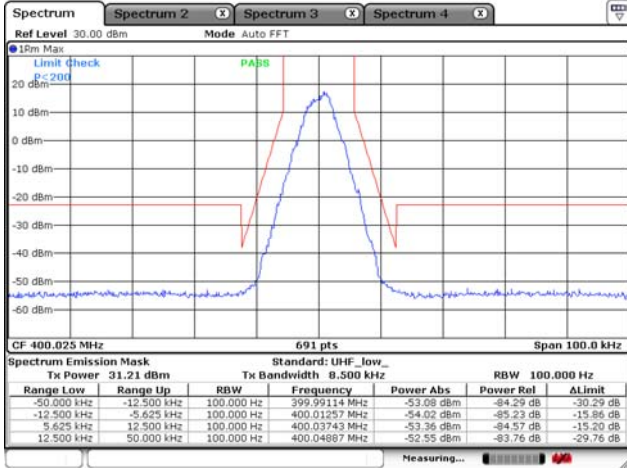

CH Low / High power

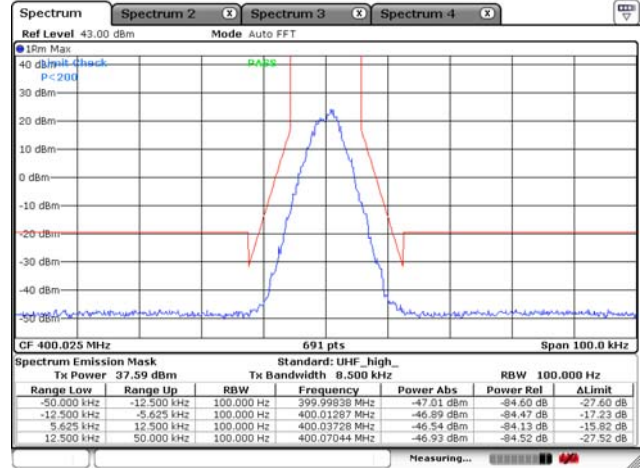

CH Middle / Low power

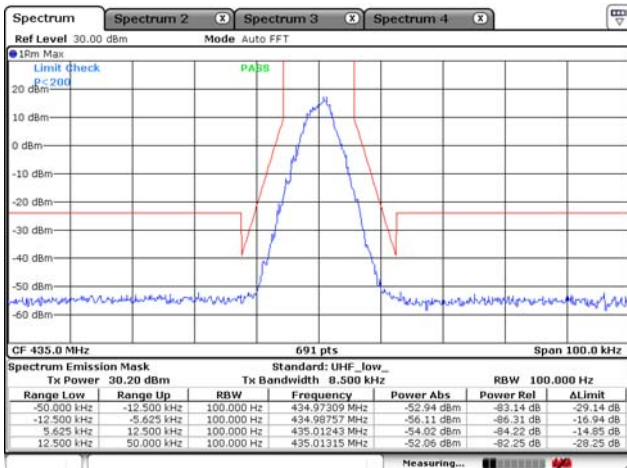

CH Middle / High power

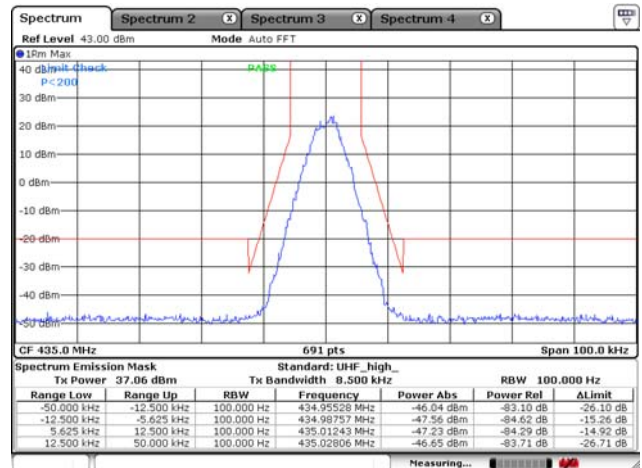

CH High / Low power

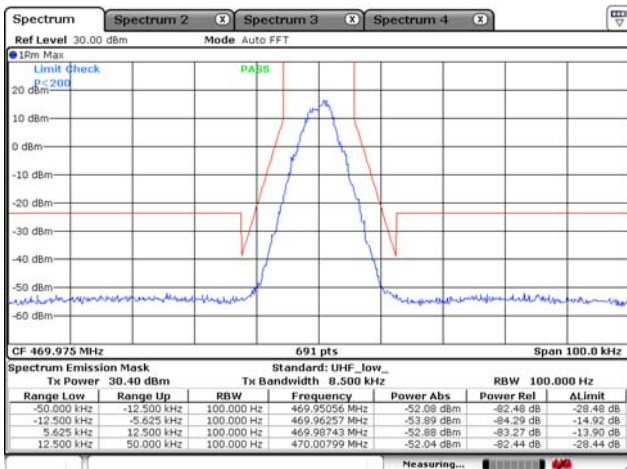

CH High / High power

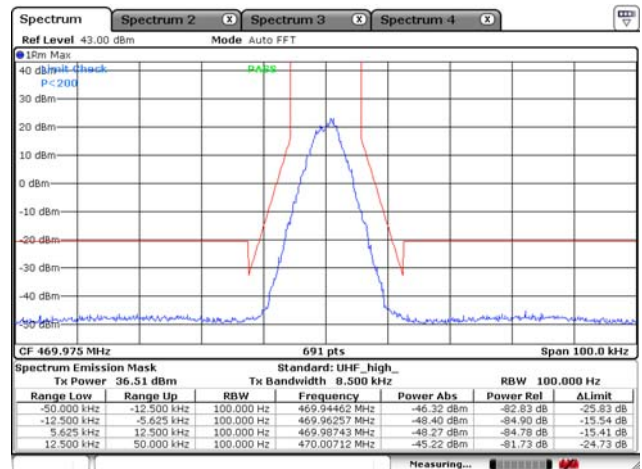

5.5 Spurious Emission On Antenna Port

5.5.1 Standard Applicable [FCC §90.210(d)]

Emission Mask D: 12.5 kHz channel bandwidth equipment. For transmitters designed to operate with a 12.5 kHz channel bandwidth, any emission must be attenuated below the power (P) of the highest emission contained within the authorized bandwidth as follows:

- 1) For any frequency removed from the center of the authorized bandwidth f_0 to 5.625 kHz removed from f_0 , 0 dB.
- 2) On any frequency removed from the center of the authorized bandwidth by a displacement frequency (f_d in kHz) of more than 5.626 kHz but no more than 12.5 kHz, at least $7.27 (f_d - 2.88 \text{ kHz})$ dB.
- 3) On any frequency removed from the center of the authorized bandwidth by a displacement frequency (f_d in kHz) of more than 12.5 kHz: At least $50 + 10 \log (P)$ dB or 70 dB, whichever is the lesser attenuation.

5.5.2 Test Environment conditions

- Ambient temperature : (20 - 21) °C • Relative Humidity : (47 - 48) % R.H.

5.5.3 Measurement Procedure

The carrier was modulated 100 % using a 2 500 Hz tone. The spectrum was scanned from the lowest frequency generated to at least the 10th harmonic of the fundamental. The measurements were made in accordance with standard ANSI/TIA 603-D: 2010. The RBW = 100 kHz, VBW = 300 kHz and the span set to 10.0 MHz and the spectrum was scanned from 30 MHz to the 10th harmonic of the fundamental. Above 1 GHz the resolution bandwidth was 1 MHz and the VBW = 3 MHz and the span to 50 MHz.

5.5.4 Test setup

Refer 5.3.4

5.5.5 Measurement Result

Analog / 400.025 MHz / Low power

Emission Frequency [MHz]	Level below Carrier [dBc]	Margin [dB]	Limit [dBc]	Test Results
800.06	57.41	7.41	50	Compliance

Analog / 435.000 MHz / Low power

Emission Frequency [MHz]	Level below Carrier [dBc]	Margin [dB]	Limit [dBc]	Test Results
869.98	58.61	8.61	50	Compliance

Analog / 469.975 MHz / Low power

Emission Frequency [MHz]	Level below Carrier [dBc]	Margin [dB]	Limit [dBc]	Test Results
201.61	63.53	13.53	50	Compliance

Analog / 400.025 MHz / High power

Emission Frequency [MHz]	Level below Carrier [dBc]	Margin [dB]	Limit [dBc]	Test Results
800.13	61.65	4.65	57	Compliance

Analog / 435.000 MHz / High power

Emission Frequency [MHz]	Level below Carrier [dBc]	Margin [dB]	Limit [dBc]	Test Results
870.08	63.22	6.22	57	Compliance

Analog / 469.975 MHz / High power

Emission Frequency [MHz]	Level below Carrier [dBc]	Margin [dB]	Limit [dBc]	Test Results
940.00	63.33	6.33	57	Compliance

Digital / 400.025 MHz / Low power

Emission Frequency [MHz]	Level below Carrier [dBc]	Margin [dB]	Limit [dBc]	Test Results
800.06	57.65	7.65	50	Compliance

Digital / 435.000 MHz / Low power

Emission Frequency [MHz]	Level below Carrier [dBc]	Margin [dB]	Limit [dBc]	Test Results
870.44	56.83	6.83	50	Compliance

Digital / 469.975 MHz / Low power

Emission Frequency [MHz]	Level below Carrier [dBc]	Margin [dB]	Limit [dBc]	Test Results
835.07	63.11	13.11	50	Compliance

Digital / 400.025 MHz / High power

Emission Frequency [MHz]	Level below Carrier [dBc]	Margin [dB]	Limit [dBc]	Test Results
800.13	62.58	5.58	57	Compliance

Digital / 435.000 MHz / High power

Emission Frequency [MHz]	Level below Carrier [dBc]	Margin [dB]	Limit [dBc]	Test Results
870.08	63.59	6.59	57	Compliance

Digital / 469.975 MHz / High power

Emission Frequency [MHz]	Level below Carrier [dBc]	Margin [dB]	Limit [dBc]	Test Results
940	63.32	6.32	57	Compliance

5.5.6 Test Plot

■ Analog

CH Low / Low power

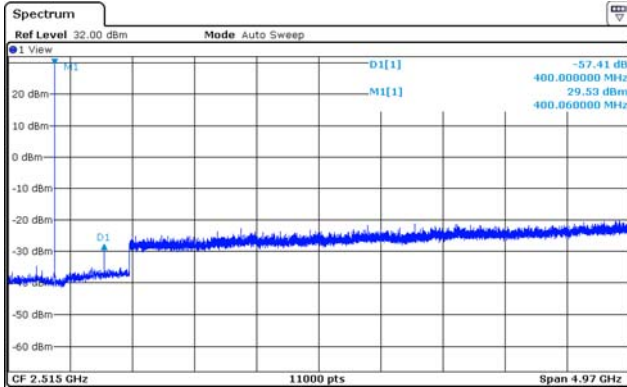

CH Low / High power

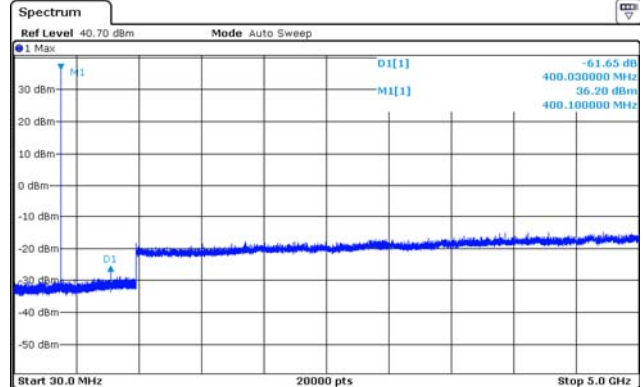

CH Middle / Low power

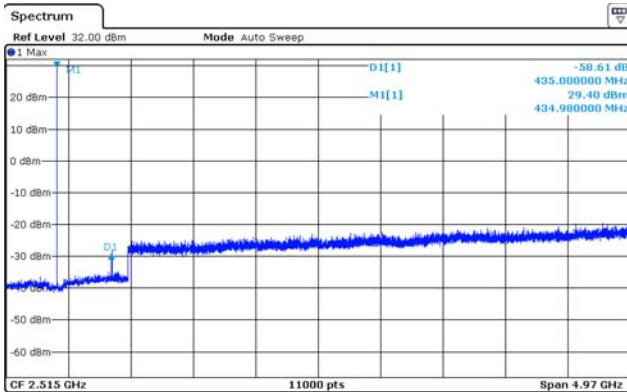

CH Middle / High power

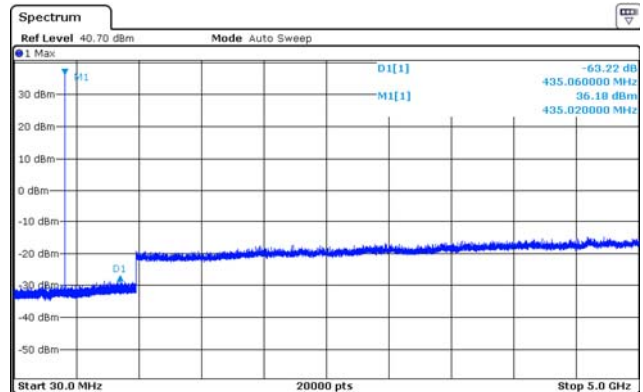

CH High / Low power

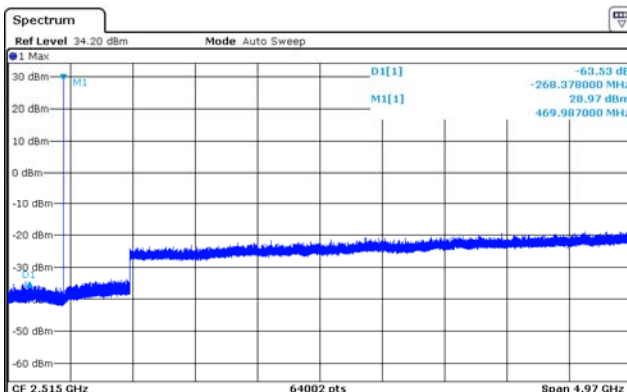

CH High / High power

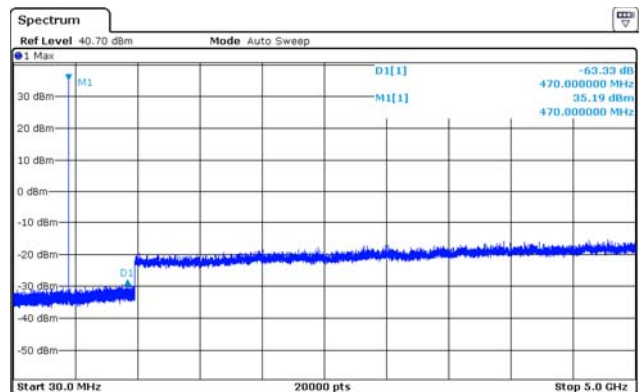

■ Digital (Voice and Data)

CH Low / Low power

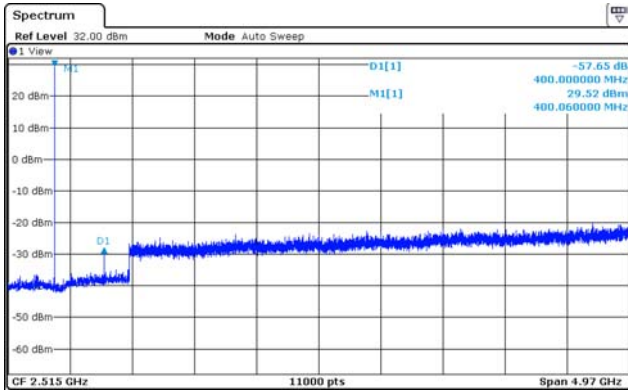

CH Low / High power

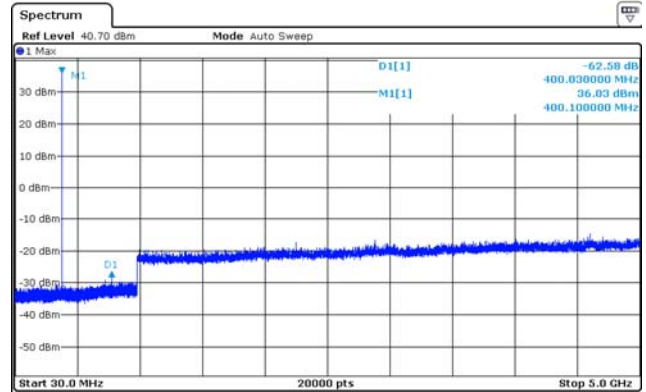

CH Middle / Low power

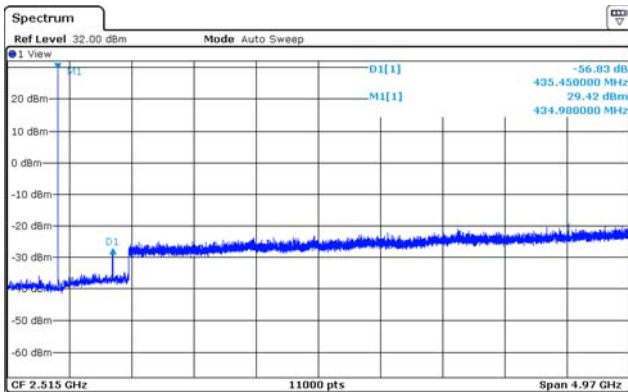

CH Middle / High power

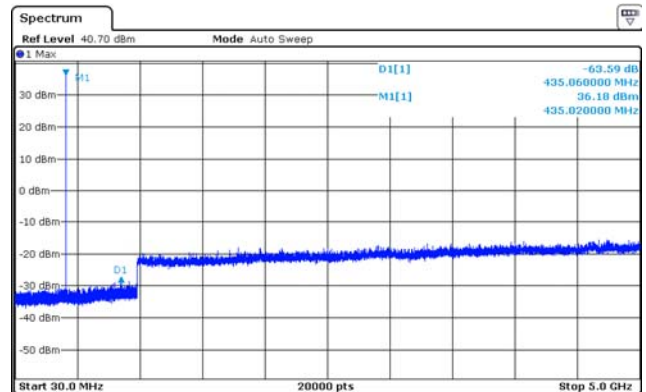

CH High / Low power

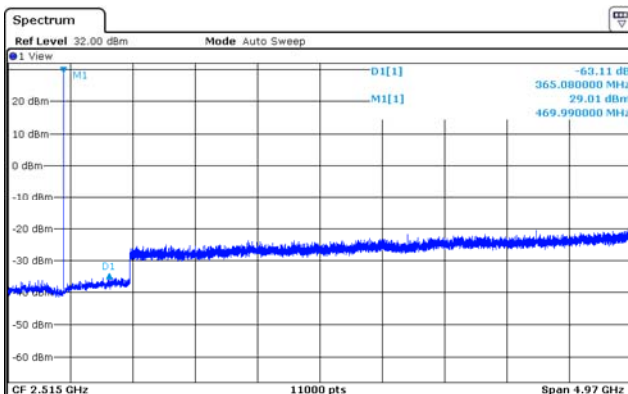

CH High / High power

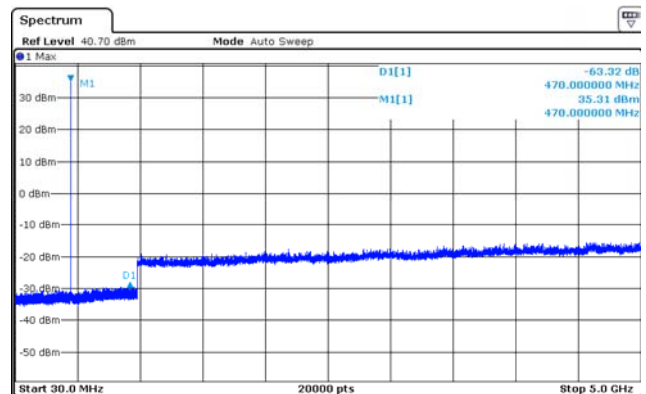

5.6 Transmitter Radiated Unwanted Emissions

5.6.1 Standard Applicable [FCC §90.210(d) & 2.1053]

The power of any emission outside a licensee's frequency band(s) of operation shall be attenuated below the transmitter power (P) within the licensed band(s) of operation, measured in watts, by at least $[50+10 \log (P)]$ (e.i.r.p. -20 dBm)

5.6.2 Test Environment conditions

- Ambient temperature : (20 - 21) °C • Relative Humidity : (47 - 48) % R.H.

5.6.3 Measurement Procedure

The EUT was setup according to ANSI/TIA-603-E-2016 for compliance to FCC 47CFR part 90 requirements.

As a below test procedure (①~⑬), The result value of measurement is performed to condition of the below; The EUT will operate in continuous transmission mode during the time necessary to perform the measured of the frequency. Substitution method was performed to determine the actual P_{erp} (or P_{eirp}) emission levels of the EUT.

The following test procedure as below;

The test is performed in a fully pyramidal chamber to determine the accurate frequencies, after maximum emissions level will be checked on a test chamber and measuring distance is 3 m from EUT to test antenna.

- ① The EUT was set on with continuous transmission mode and placed on a 0.8 meter high non-conductive table on the chamber.
- ② The test antenna is used on Bi-Log antenna at above 30 MHz, and used on Horn antenna at 1 GHz and then the measurements are repeated with the test antenna for vertical and horizontal polarization. The output of the test antenna will be connected to a measuring receiver, and it is set to tuned over the required standard measuring frequency range.
- ③ At each frequency at which a relevant spurious component is detected, the test antenna will be raised and lowered through the specified range of heights until an maximum signal level is detected on the measuring receiver.
- ④ The EUT is position x, y, z axis on rotating through 360 degrees in the horizontal plane, until the Max. signal level is detected by the measuring receiver.
- ⑤ The receiver is scanned from requested measuring frequency band and then the maximum meter reading is recorded. The radiated emissions were measured with requested standard specification (detector and resolution bandwidth etc.)
- ⑥ The EUT was then removed and replaced with substitution antenna .The center of the antenna was approximately at the same location as the center of the EUT, and calibrated for the frequency of the spurious component detected.
- ⑦ Signal generator output port connected with substitution antenna input port. If necessary, may use shield cable between signal generator and substitution antenna
- ⑧ The frequency of the calibrated signal generator is set to frequency of the spurious component detected, and the input attenuator setting of the measuring receiver was adjust in order to increase the sensitivity of the measuring receiver, if necessary
- ⑨ The test antenna was raised and lowered through the specified range of heights to ensure that maximum signal is received.
- ⑩ The input signal to the substitution antenna was be adjusted until an equal or a known related level to that

detected from the transmitter is obtained on the measuring receiver.

- ⑪ The input signal to the substitution antenna was be recorded as a power level and corrected for any change of input attenuator setting of the measuring receiver
- ⑫ The measure of P_{erp} (or P_{eirp}) the spurious components is the larger of the two power levels recorded for each spurious component at the input to the substitution antenna, corrected for the gain of the substitution antenna, if necessary.
- ⑬ It is correction to signal generator's offset value. In this case of P_{erp} (or P_{eirp}) shall calculated as follow as formula ;
 - P_{erp} (or P_{eirp}) = Signal generator level (dBm) – Cable loss(dB)

The measurement frequency range from 30 MHz - 10th Harmonic of fundamental was investigated.

5.6.5 Test Setup

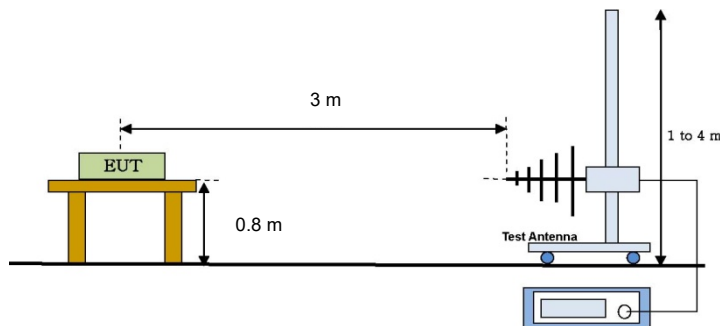

[Radiated measurement setup_Below than 1 GHz]

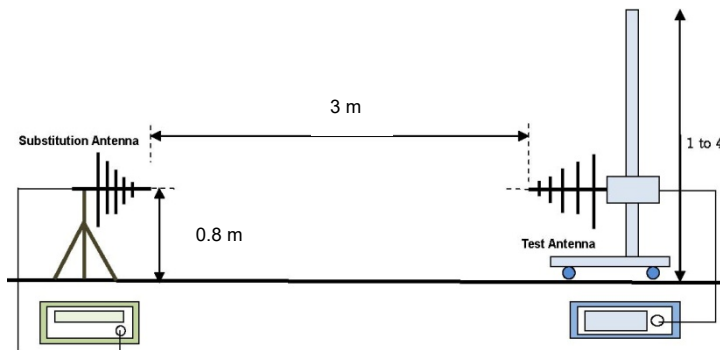

[Effective Radiated Power measurement setup]

※ Above the test antenna is used on Horn antenna at above 1 GHz.

Measurement Uncertainty

All measurements involve certain levels of uncertainties. The factors contributing to uncertainties are test receiver, Cable loss, Antenna factor calibration, antenna directivity, antenna factor variation with height, antenna phase center variation, Antenna frequency interpolation, measurement distance variation, Site imperfection, mismatch, and system repeatability based on NIS 80,81.

Radiated Emission measurement: Below 1 GHz: 3.66 dB (CL: Approx 95 %, k=2)
 Above 1 GHz: 4.04 dB (CL: Approx 95 %, k=2)



5.6.6 Measurement Result

The following frequencies were selected based on the antenna conducted results, the worst case for each mode are presented.

Analog / 400.025 MHz / High power

Emission Frequency [MHz]	Level below Carrier [dBc]	Margin [dB]	Limit [dBc]	Test Results
800.10	64.18	14.18	50	Compliance

Note: The formula for limit is below;
 $50+10 \log (P)$ where, P = EUT's output power in W
Therefore $50+10\log(1) = 50$

Digital / 400.025 MHz / High power

Emission Frequency [MHz]	Level below Carrier [dBc]	Margin [dB]	Limit [dBc]	Test Results
800.10	65.10	8.1	57	Compliance

Note: The formula for limit is below;
 $50+10 \log (P)$ where, P = EUT's output power in W
Therefore $50+10\log(5) = 57$

5.7 Frequency Stability

5.7.1 Standard Applicable [FCC §90.213 & 2.1055]

The EUT is placed in a temperature chamber, the EUT is allowed to soak at room temperature for 20 minutes and a reference frequency is read. The temperature is then lowered to -30 C and stepped up to 50 C soaking 20 minutes at each temperature then a frequency is read. According to §90.213, the frequency stability limit is 2.5 ppm for 12.5 kHz channel separation.

5.7.2 Test Environment conditions

- Ambient temperature : (20 - 21) °C • Relative Humidity : (47 - 48) % R.H.

5.6.3 Measurement Procedure

EUT connect to Spectrum analyzer, test is performed in T&H chamber.

These measurements shall also be performed at normal and extreme test conditions.

- Test Method : ANSI/TIA-603-E-2016, clause 3.2.2 for frequency stability tests
 - Frequency stability with respect to ambient temperature
 - Frequency stability when varying supply voltage

5.7.4 Test setup

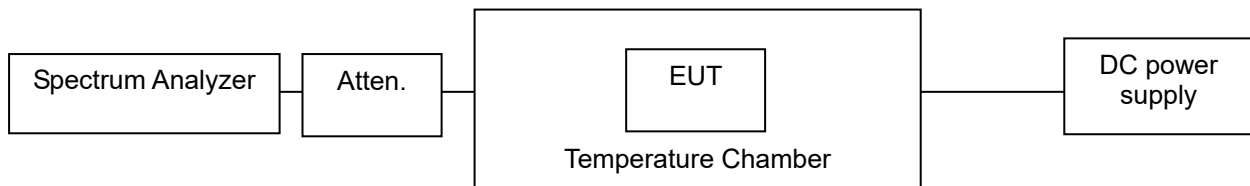

5.7.5 Measurement Result

Analog

Temp(°C)	Power Supply	Measured Freq(MHz)	Freq Drift(ppm)
50	DC 7.4 (Vnom)	435.000 110	0.25
40	DC 7.4 (Vnom)	435.000 100	0.23
30	DC 7.4 (Vnom)	435.000 041	0.09
20	DC 7.4 (Vnom)	435.000 030	0.07
10	DC 7.4 (Vnom)	435.000 035	0.08
0	DC 7.4 (Vnom)	435.000 021	0.05
-10	DC 7.4 (Vnom)	434.999 962	-0.09
-20	DC 7.4 (Vnom)	434.999 971	-0.07
-30	DC 7.4 (Vnom)	434.999 970	-0.07
Nom Temperature	DC 6.3 (Vmin)	435.000 029	0.07
Nom Temperature	DC 8.5 (Vmax)	435.000 028	0.06



Digital (Voice and Data)

Temp(°C)	Power Supply	Measured Freq(MHz)	Freq Drift(ppm)
50	DC 7.4 (Vnom)	435.000 152	0.35
40	DC 7.4 (Vnom)	435.000 133	0.31
30	DC 7.4 (Vnom)	435.000 125	0.29
20	DC 7.4 (Vnom)	435.000 116	0.27
10	DC 7.4 (Vnom)	435.000 105	0.24
0	DC 7.4 (Vnom)	435.000 086	0.20
-10	DC 7.4 (Vnom)	434.999 981	-0.04
-20	DC 7.4 (Vnom)	434.999 975	-0.06
-30	DC 7.4 (Vnom)	434.999 977	-0.05
Nom Temperature	DC 6.3 (Vmin)	435.000 108	0.25
Nom Temperature	DC 8.5 (Vmax)	435.000 109	0.25

5.8 Transmitter Frequency Behavior

5.8.1 Standard Applicable [FCC §90.214]

Transient frequencies must be within the maximum frequency difference limits during the time intervals indicated:

Time Intervals	Maximum frequency difference	All equipment (421 to 512 MHz)
Transient Frequency Behavior for Equipment Designed to operate on the 12.5 kHz Channels		
t ₁ ⁴	± 12.5 kHz	10 ms
t ₂	± 6.25 kHz	25 ms
t ₃ ⁴	± 12.5 kHz	10 ms

5.8.2 Test Environment conditions

- Ambient temperature : (20 - 21) °C • Relative Humidity : (47 - 48) % R.H.

5.8.3 Measurement Procedure

- Connect the EUT and test equipment as shown on the following test setup diagram.
- Set the Spectrum Analyzer to measure FM deviation, and tune the RF frequency to the transmitter assigned frequency.
- Set the signal generator to the assigned transmitter frequency and modulate it with a 1 kHz tone at ±12.5 kHz deviation and set its output level to -100 dBm.
- Turn on the transmitter.
- Supply sufficient attenuation via the RF attenuator to provide an input level to the Spectrum Analyzer that is 40 dB below the maximum allowed input power when the transmitter is operating at its rated power level. Note this power level on the Spectrum Analyzer as P₀.
- Turn off the transmitter.
- Adjust the RF level of the signal generator to provide RF power equal to P₀. This signal generator RF level shall be maintained throughout the rest of the measurement.
- Remove the attenuation 1, so the input power to the Spectrum Analyzer is increased by 30 dB when the transmitter is turned on.
- Adjust the vertical amplitude control of the spectrum analyzer to display the 1000 Hz at ±4 divisions vertically centered on the display. Set trigger mode of the Spectrum Analyzer to "Video", and tune the "trigger level" on suitable level. Then set the "trigger offset" to -10ms for turn on and -15 ms for turn off.
- Turn on the transmitter and the transient wave will be captured on the screen of Spectrum Analyzer. Observe the stored display. The instant when the 1 kHz test signal is completely suppressed is considered to be ton. The trace should be maintained within the allowed divisions during the period t₁ and t₂.

5.8.4 Test setup

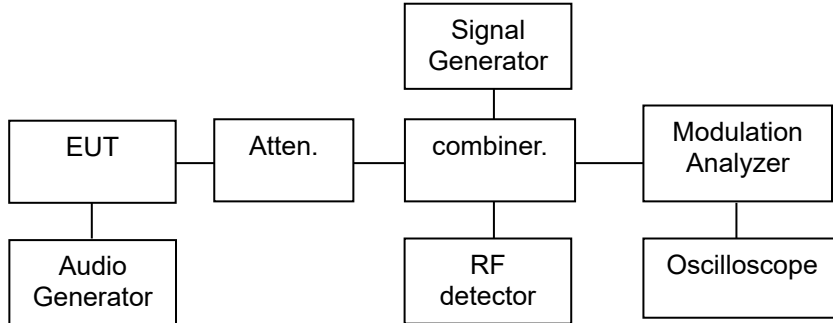

5.8.5 Measurement Result

OFF - ON

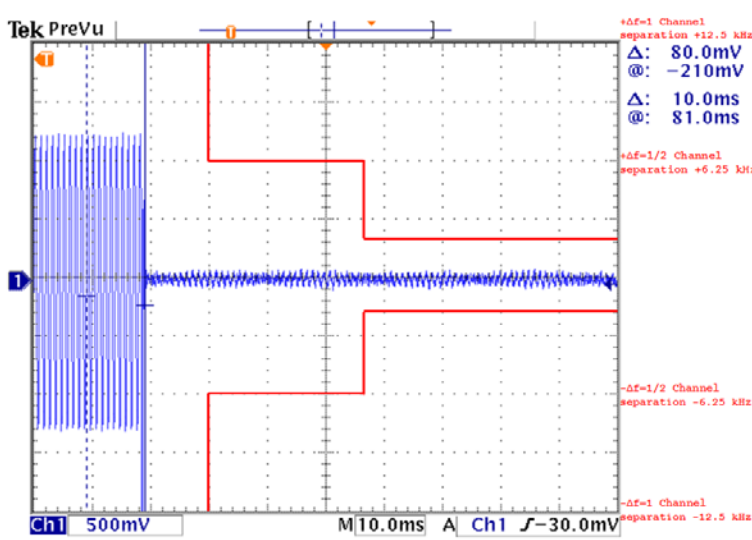

ON - OFF

