



Shenzhen CTL Testing Technology Co., Ltd.
Tel: +86-755-89486194 Fax: +86-755-26636041

FCC PART 15 SUBPART C TEST REPORT

Report Reference No.: CTL1608293324-WF02

Compiled by:
(position+printed name+signature)

Happy Guo
(File administrators)

Happy Guo

Tested by:
(position+printed name+signature)

Nice Nong
(Test Engineer)

Nice Nong

Approved by:
(position+printed name+signature)

Tracy Qi
(Manager)

Tracy Qi

Product Name.....: Field Tablet (7" Touch screen Viewer for Android™)

Model/Type reference.....: MCA13052

Trade Mark.....: Moultrie®, Android™

FCC ID.....: 2AJQ6MCA13052

Applicant's name.....: **EBSCO Industries Inc., DBA PRADCO Outdoor Brands**

Address of applicant.....: 2600 Corporate Drive., Suite 250 Birmingham, AL.35242

Test Firm.....: **Shenzhen CTL Testing Technology Co., Ltd.**

Address of Test Firm.....: Floor 1-A, Baisha Technology Park, No.3011, Shahehexi Road, Nanshan District, Shenzhen, China 518055

Test specification.....:

Standard.....: **FCC Part 15.249:** Operation within the bands 920-928 MHz, 2400-2483.5 MHz, 5725-5850 MHz and 24.0 - 24.25 GHz.

TRF Originator.....: Shenzhen CTL Testing Technology Co., Ltd.

Master TRF.....: Dated 2011-01

Date of Receipt.....: Aug. 29, 2016

Date of Test Date.....: Aug. 29, 2016-Sept. 20, 2016

Data of Issue.....: Sept. 20, 2016

Result.....: **PASS**

Shenzhen CTL Testing Technology Co., Ltd. All rights reserved.

This publication may be reproduced in whole or in part for non-commercial purposes as long as the Shenzhen CTL Testing Technology Co., Ltd. is acknowledged as copyright owner and source of the material. Shenzhen CTL Testing Technology Co., Ltd. takes no responsibility for and will not assume liability for damages resulting from the reader's interpretation of the reproduced material due to its placement and context.

TEST REPORT

Test Report No. :	CTL1608293324-WF02	Sept. 20, 2016
		Date of issue

Equipment under Test : Field Tablet (7" Touch screen Viewer for Android™)

Model /Type : MCA13052

Applicant : **EBSCO Industries Inc., DBA PRADCO Outdoor Brands**

Address : 2600 Corporate Drive., Suite 250 Birmingham, AL.35242

Manufacturer : **EBSCO Industries Inc., DBA PRADCO Outdoor Brands**

Address : 2600 Corporate Drive., Suite 250 Birmingham, AL.35242

Test Result according to the standards on page 4:	PASS
--	-------------

The test report merely corresponds to the test sample.
It is not permitted to copy extracts of these test result without the written permission of the test laboratory.

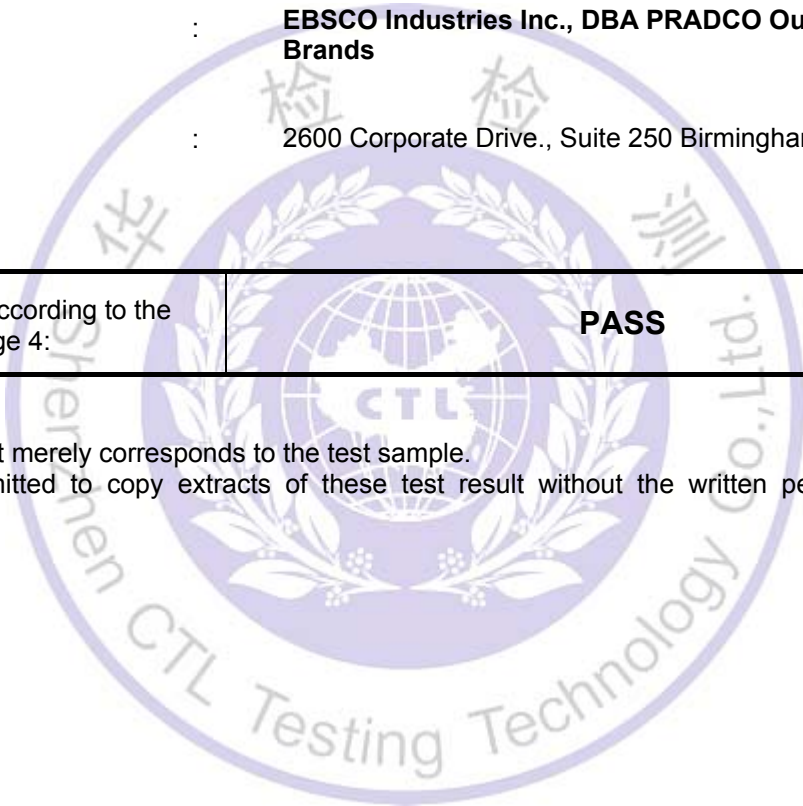

Contents

1.	<u>TEST STANDARDS</u>	4
2.	<u>SUMMARY</u>	5
2.1.	Equipment Under Test	5
2.2.	Description of the Equipment under Test (EUT)	5
2.3.	EUT operation mode	6
2.4.	EUT configuration	6
2.5.	Related Submittal(s) / Grant (s)	6
2.6.	Modifications	6
3.	<u>TEST ENVIRONMENT</u>	7
3.1.	Address of the test laboratory	7
3.2.	Test Facility	7
3.3.	Environmental conditions	7
3.4.	Configuration of Tested System	7
3.5.	Statement of the measurement uncertainty	8
3.6.	Equipments Used during the Test	9
4.	<u>TEST CONDITIONS AND RESULTS</u>	10
4.1.	Conducted Emissions Test	10
4.2.	Transmitter Radiated Unwanted Emissions and Bandedge	13
4.3.	Occupied Bandwidth Measurement	19
5.	<u>ANTENNA REQUIREMENT</u>	21
6.	<u>TEST SETUP PHOTOS OF THE EUT</u>	22
7.	<u>EXTERNAL AND INTERNAL PHOTOS OF THE EUT</u>	24

1. TEST STANDARDS

The tests were performed according to following standards:

[FCC Rules Part 15.249](#): Operation within the bands 902 - 928 MHz, 2400 - 2483.5 MHz, 5725 - 5875 MHz, and 24.0 - 24.25 GHz.

[ANSI C63.10-2013](#)

[ANSI C63.4-2014](#)



2. SUMMARY

2.1. Equipment Under Test

Power supply system utilised

Power supply voltage : ● 120V / 60 Hz ○ 115V / 60Hz
 ○ 12 V DC ○ 24 V DC
 ● Other (specified in blank below)

DC 3.7V from battery

2.2. Description of the Equipment under Test (EUT)

Product Name:	Field Tablet (7" Touch screen Viewer for Android™)
Model/Type reference:	MCA13052
Power supply:	DC 3.7V from battery, charged by AC adapter
WIFI	
Supported type:	802.11b/802.11g/802.11n(HT20) /802.11n(HT40)
Modulation:	802.11b: DSSS 802.11g/802.11n(HT20)/802.11n(HT40): OFDM
Operation frequency:	802.11b/802.11g/802.11n(HT20): 2412MHz~2462MHz 802.11n(HT40): 2422MHz~2452MHz
Channel number:	802.11b/802.11g/802.11n(HT20): 11 802.11n(HT40):7
Channel separation:	5MHz
Antenna type:	Internal Antenna
Antenna gain:	2dBi
Bluetooth 3.0	
Modulation:	GFSK,8DPSK,π/4DQPSK
Operation frequency:	2402MHz~2480MHz
Channel number:	79
Channel separation:	1MHz
Antenna type:	Internal Antenna
Antenna gain:	2dBi
Bluetooth 4.0LE	
Modulation:	GFSK
Operation frequency:	2402MHz~2480MHz
Channel number:	40
Channel separation:	2MHz
Antenna type:	Internal Antenna
Antenna gain:	2dBi

Note: For more detailed features description, please refer to the manufacturer's specifications or the User's Manual .
 This report is only for Bluetooth 4.0LE.

Channel List:

Channel	Frequency (MHz)	Channel	Frequency (MHz)
00	2402	21	2444
01	2404	22	2446
02	2406	23	2448
03	2408	24	2450
04	2410	25	2452
05	2412	26	2454
06	2414	27	2456
07	2416	28	2458
08	2418	29	2460
09	2420	30	2462
10	2422	31	2464
11	2424	32	2466
12	2426	33	2468
13	2428	34	2470
14	2430	35	2472
15	2432	36	2474
16	2434	37	2476
17	2436	38	2478
18	2438	39	2480
19	2440		
20	2442		

For more details, refer to the user's manual of the EUT.
Serial number: Prototype

2.3. EUT operation mode

Test Mode(TM)	Description	Remark
TM1	Bottom Channel Transmitting	/
TM2	Middle Channel Transmitting	/
TM3	Top Channel Transmitting	/
TM4	Charging and keeping TX	power by USB

The field strength of radiation emission was measured in the following position: EUT stand-up position (Y axis), lie-down position (X, Z axis).

The following data show only with the worst case setup.

The worst case of Y axis was reported.

Based on client request, all normal using modes of the normal function were tested but only the worst test data of the worst mode is reported by this report.

2.4. EUT configuration

The following peripheral devices and interface cables were connected during the measurement:

○ - supplied by the manufacturer

● - supplied by the lab

○ AC adapter

Shenzhen Eagletron Electronic
Manufacturer: Co.,LTD.
Model No.: DYED05020U1EU

2.5. Related Submittal(s) / Grant (s)

This submittal(s) (test report) is intended for FCC ID: 2AJQ6MCA13052 filing to comply with Section 15.249 of the FCC Part 15, Subpart C Rules.

2.6. Modifications

No modifications were implemented to meet testing criteria.

3. TEST ENVIRONMENT

3.1. Address of the test laboratory

Shenzhen CTL Testing Technology Co., Ltd.
Floor 1-A, Baisha Technology Park, No. 3011, Shaheji Road, Nanshan, Shenzhen 518055 China

There is one 3m semi-anechoic chamber and two line conducted labs for final test. The Test Sites meet the requirements in documents ANSI C63.4 and CISPR 22/EN 55022 requirements.

3.2. Test Facility

The test facility is recognized, certified, or accredited by the following organizations:

IC Registration No.: 9618B

The 3m alternate test site of Shenzhen CTL Testing Technology Co., Ltd. EMC Laboratory has been registered by Certification and Engineer Bureau of Industry Canada for the performance of with Registration No.: 9618B on November 13, 2013.

FCC-Registration No.: 970318

Shenzhen CTL Testing Technology Co., Ltd. EMC Laboratory has been registered and fully described in a report filed with the (FCC) Federal Communications Commission. The acceptance letter from the FCC is maintained in our files. Registration 970318, December 19, 2013.

3.3. Environmental conditions

During the measurement the environmental conditions were within the listed ranges:

Temperature: 15-35 ° C

Humidity: 30-60 %

Atmospheric pressure: 950-1050mbar

3.4. Configuration of Tested System

Fig. 2-1 Configuration of Tested System

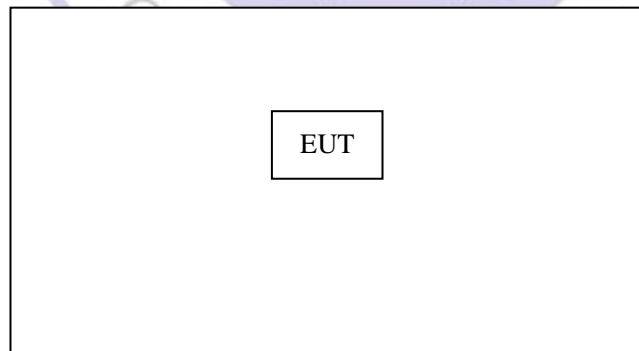

3.5. Statement of the measurement uncertainty

The data and results referenced in this document are true and accurate. The reader is cautioned that there may be errors within the calibration limits of the equipment and facilities. The measurement uncertainty was calculated for all measurements listed in this test report acc. to CISPR 16 - 4 „Specification for radio disturbance and immunity measuring apparatus and methods – Part 4: Uncertainty in EMC Measurements“ and is documented in the Shenzhen CTL Testing Technology Co., Ltd. quality system acc. to DIN EN ISO/IEC 17025. Furthermore, component and process variability of devices similar to that tested may result in additional deviation. The manufacturer has the sole responsibility of continued compliance of the device.

Hereafter the best measurement capability for CTL laboratory is reported:

Test	Range	Measurement Uncertainty	Notes
Radiated Emission	30~1000MHz	4.10dB	(1)
Radiated Emission	1~26.5GHz	4.32dB	(1)
Conducted Disturbance	0.15~30MHz	3.20dB	(1)

- (1) This uncertainty represents an expanded uncertainty expressed at approximately the 95% confidence level using a coverage factor of k=2.



3.6. Equipments Used during the Test

Test Equipment	Manufacturer	Model No.	Serial No.	Calibration Date	Calibration Due Date
ULTRA-ROADBAND ANTENNA	Sunol Sciences Corp.	JB1	A061713	2016/06/02	2017/06/01
EMI Test Receiver	R&S	ESCI	103710	2016/06/02	2017/06/01
Spectrum Analyzer	Agilent	E4407B	MY41440676	2016/05/21	2017/05/20
Controller	EM Electronics	Controller EM 1000	N/A	2016/05/21	2017/05/20
Horn Antenna	Sunol Sciences Corp.	DRH-118	A062013	2016/05/19	2017/05/18
Active Loop Antenna	Daze	ZN30900A	N/A	2016/05/19	2017/05/18
LISN	R&S	ENV216	3560.6550.12	2016/06/02	2017/06/01
LISN	R&S	ESH2-Z5	860014/010	2016/06/02	2017/06/01
ISN	FCC	F-071115-1057-1-09	11229	2016/05/19	2017/05/18
Amplifier	Agilent	8349B	3008A02306	2016/05/19	2017/05/18
Amplifier	Agilent	8447D	2944A10176	2016/05/19	2017/05/18
Transient Limiter	SCHWARZCECK	VTSD 9561F	9666	2016/06/02	2017/06/01
Radio Communication Tester	R&S	CMU200	115419	2016/05/22	2017/05/21
Temperature/Humidity Meter	Gangxing	CTH-608	02	2016/05/20	2017/05/19
SIGNAL GENERATOR	Agilent	E4421B	US40051744	2016/05/20	2017/05/19
Power Meter	Agilent	U2531A	TW53323507	2016/05/21	2017/05/20
Power Sensor	Agilent	U2021XA	MY5365004	2016/05/21	2017/05/20
Climate Chamber	ESPEC	EL-10KA	A20120523	2016/05/20	2017/05/19
High-Pass Filter	K&L	9SH10-2700/X12750-O/O	N/A	2016/05/20	2017/05/19
High-Pass Filter	K&L	41H10-1375/U12750-O/O	N/A	2016/05/20	2017/05/19
RF Cable	HUBER+SUHNER	RG214	N/A	2016/05/20	2017/05/19

4. TEST CONDITIONS AND RESULTS

4.1. Conducted Emissions Test

TEST CONFIGURATION

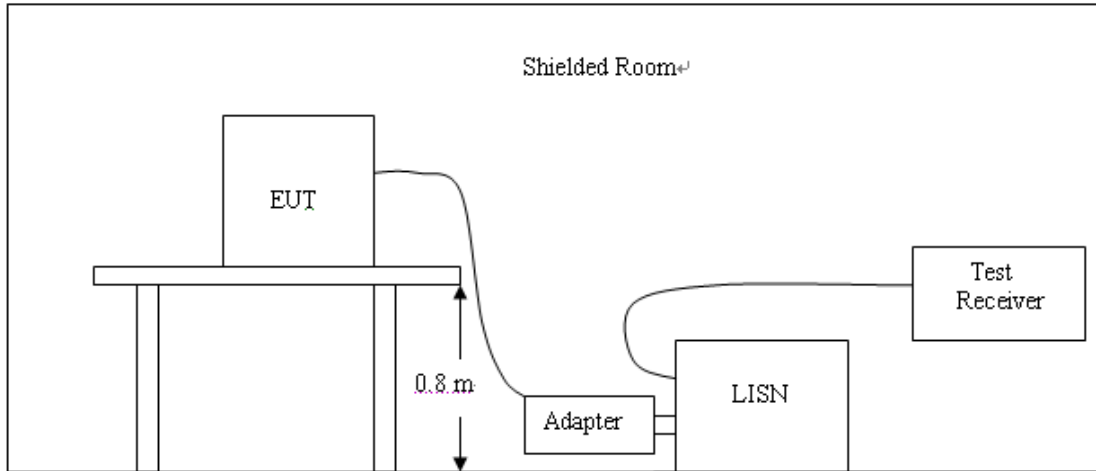

TEST PROCEDURE

- 1 The equipment was set up as per the test configuration to simulate typical actual usage per the user's manual. The EUT is a tabletop system, a wooden table with a height of 0.8 meters is used and is placed on the ground plane as per ANSI C63.10.
- 2 Support equipment, if needed, was placed as per ANSI C63.10.
- 3 All I/O cables were positioned to simulate typical actual usage as per ANSI C63.10.
- 4 If a EUT received DC power from the USB Port of Notebook PC, the PC's adapter received AC120V/60Hz power through a Line Impedance Stabilization Network (LISN) which supplied power source and was grounded to the ground plane.
- 5 All support equipments received AC power from a second LISN, if any.
- 6 The EUT test program was started. Emissions were measured on each current carrying line of the EUT using a spectrum Analyzer / Receiver connected to the LISN powering the EUT. The LISN has two monitoring points: Line 1 (Hot Side) and Line 2 (Neutral Side). Two scans were taken: one with Line 1 connected to Analyzer / Receiver and Line 2 connected to a 50 ohm load; the second scan had Line 1 connected to a 50 ohm load and Line 2 connected to the Analyzer / Receiver.
- 7 Analyzer / Receiver scanned from 150 KHz to 30MHz for emissions in each of the test modes.
- 8 During the above scans, the emissions were maximized by cable manipulation.

The RBW/VBW for 150KHz to 30MHz: 9KHz

CONDUCTED POWER LINE EMISSION LIMIT

For unintentional device, according to § 15.207(a) Line Conducted Emission Limits is as following :

Frequency (MHz)	Maximum RF Line Voltage (dBµV)			
	CLASS A		CLASS B	
	Q.P.	Ave.	Q.P.	Ave.
0.15 - 0.50	79	66	66-56*	56-46*
0.50 - 5.00	73	60	56	46
5.00 - 30.0	73	60	60	50

* Decreasing linearly with the logarithm of the frequency

For intentional device, according to §15.207(a) Line Conducted Emission Limit is same as above table.

TEST RESULTS

SCAN TABLE: "Voltage (9K-30M)FIN"

Short Description: 150K-30M Voltage

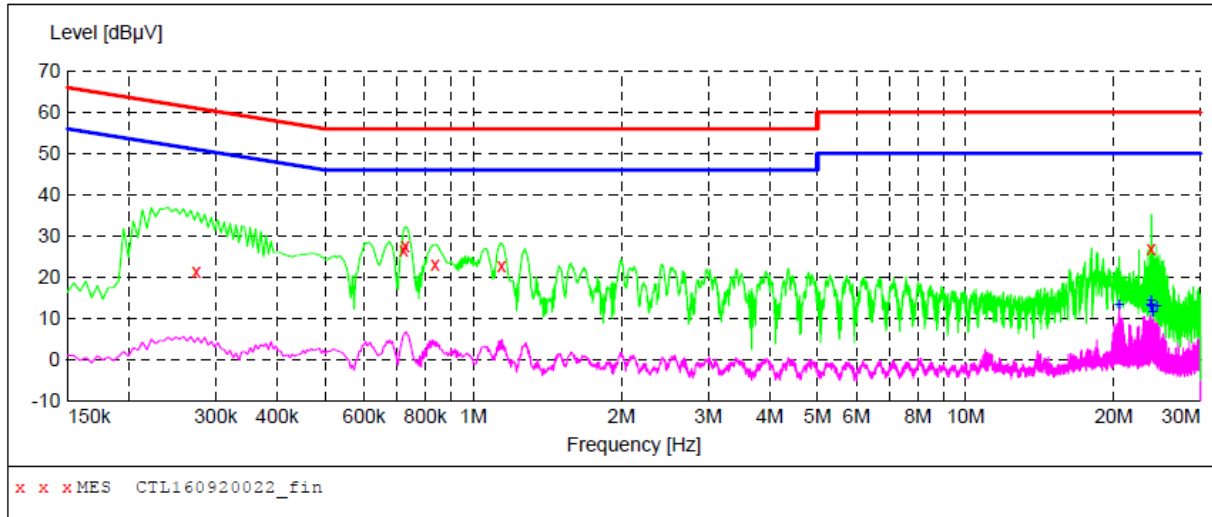

MEASUREMENT RESULT: "CTL160920022_fin"

9/20/2016 10:18AM

Frequency MHz	Level dBµV	Transd dB	Limit dBµV	Margin dB	Detector	Line	PE
0.274000	21.40	10.2	61	39.6	QP	N	GND
0.722000	26.60	10.2	56	29.4	QP	N	GND
0.728000	27.70	10.2	56	28.3	QP	N	GND
0.836000	23.00	10.2	56	33.0	QP	N	GND
1.142000	22.90	10.3	56	33.1	QP	N	GND
23.822000	26.90	11.1	60	33.1	QP	N	GND

MEASUREMENT RESULT: "CTL160920022_fin2"

9/20/2016 10:18AM

Frequency MHz	Level dBµV	Transd dB	Limit dBµV	Margin dB	Detector	Line	PE
20.516000	13.50	11.0	50	36.5	AV	N	GND
23.762000	13.50	11.1	50	36.5	AV	N	GND
23.822000	14.50	11.1	50	35.5	AV	N	GND
23.882000	12.90	11.1	50	37.1	AV	N	GND
24.002000	11.60	11.1	50	38.4	AV	N	GND
24.428000	13.10	11.1	50	36.9	AV	N	GND

SCAN TABLE: "Voltage (9K-30M) FIN"

Short Description: 150K-30M Voltage

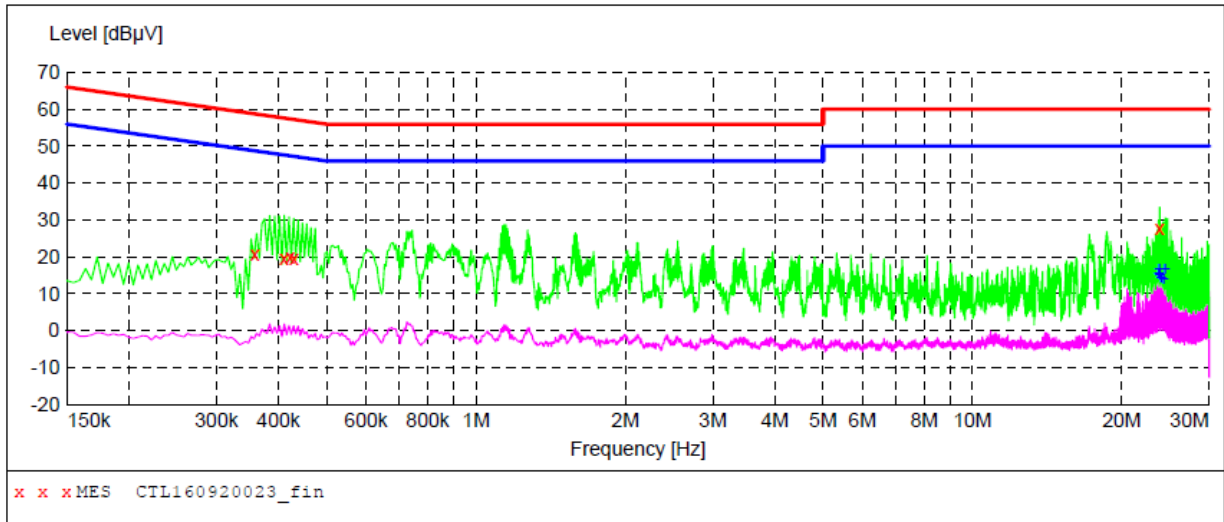

MEASUREMENT RESULT: "CTL160920023_fin"

9/20/2016 10:22AM

Frequency MHz	Level dBµV	Transd dB	Limit dBµV	Margin dB	Detector	Line	PE
0.358000	20.60	10.2	59	38.2	QP	L1	GND
0.410000	19.50	10.2	58	38.1	QP	L1	GND
0.422000	20.10	10.2	57	37.3	QP	L1	GND
0.430000	19.70	10.2	57	37.6	QP	L1	GND
23.822000	27.50	11.1	60	32.5	QP	L1	GND

MEASUREMENT RESULT: "CTL160920023_fin2"

9/20/2016 10:22AM

Frequency MHz	Level dBµV	Transd dB	Limit dBµV	Margin dB	Detector	Line	PE
23.762000	15.70	11.1	50	34.3	AV	L1	GND
23.828000	16.70	11.1	50	33.3	AV	L1	GND
23.882000	15.40	11.1	50	34.6	AV	L1	GND
24.008000	14.40	11.1	50	35.6	AV	L1	GND
24.308000	14.00	11.1	50	36.0	AV	L1	GND
24.428000	16.80	11.1	50	33.2	AV	L1	GND

4.2. Transmitter Radiated Unwanted Emissions and Bandedge

TEST CONFIGURATION

(A) Radiated Emission Test Set-Up, Frequency Below 30MHz

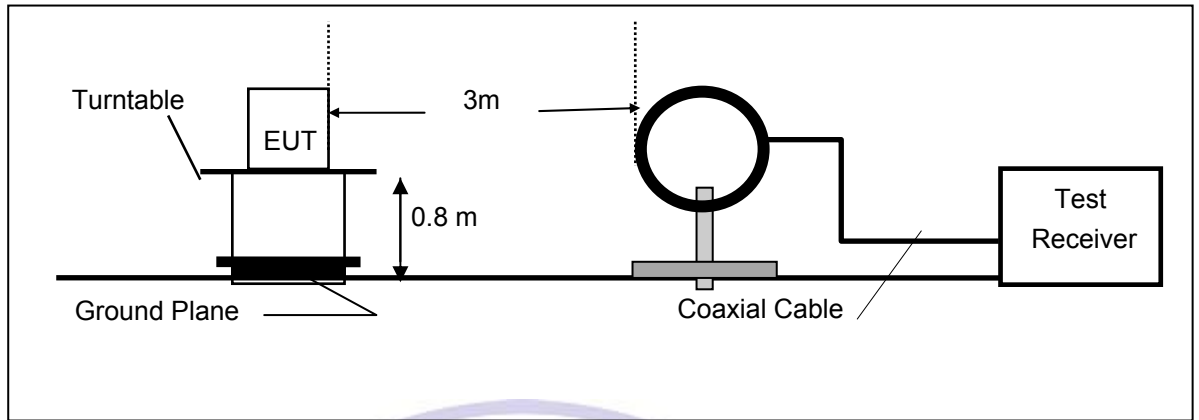

(B) Radiated Emission Test Set-Up, Frequency below 1000MHz

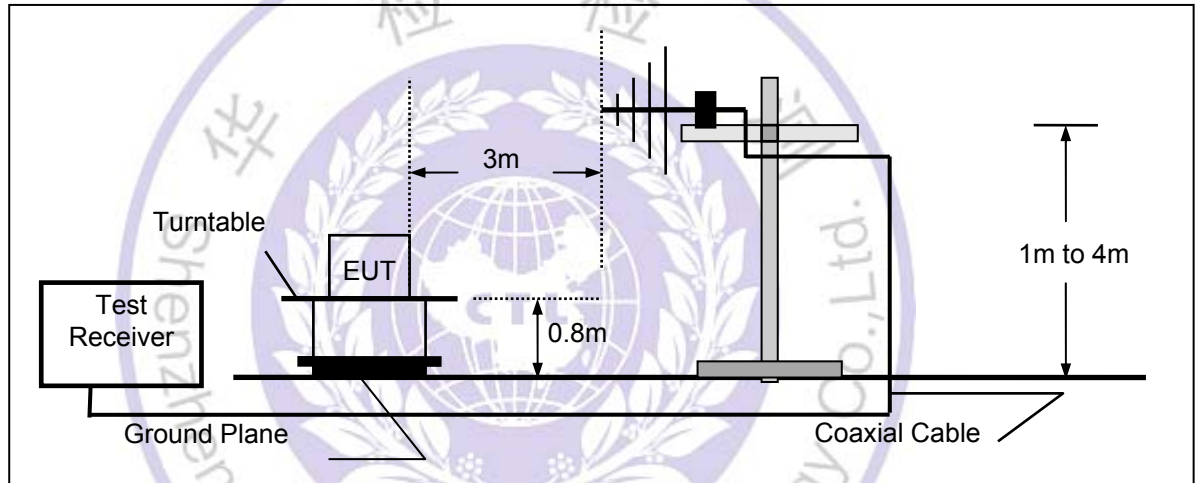

(C) Radiated Emission Test Set-Up, Frequency above 1000MHz

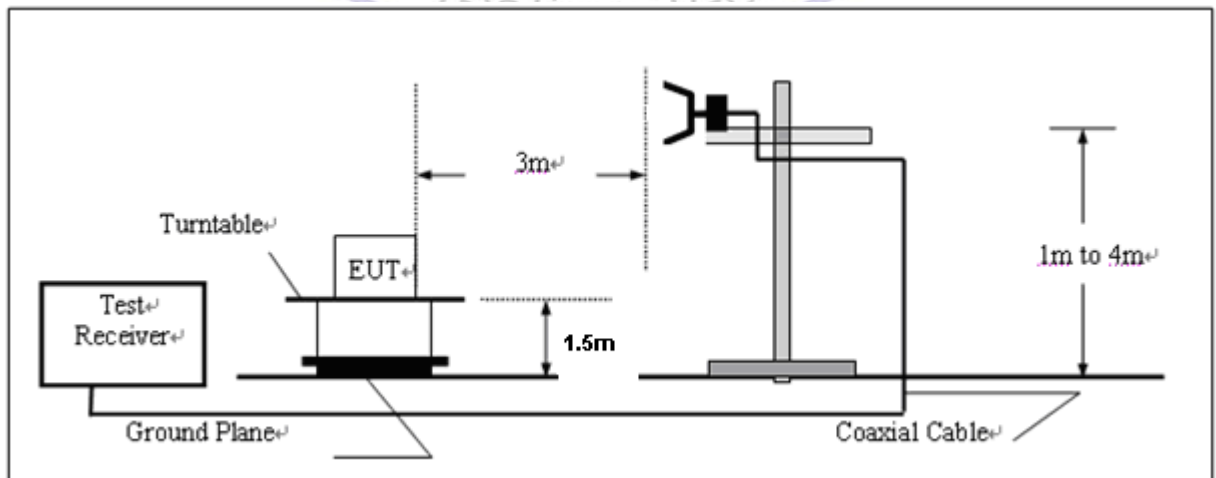

FIELD STRENGTH CALCULATION

The field strength is calculated by adding the Antenna Factor and Cable Factor and subtracting the Amplifier Gain and Duty Cycle Correction Factor(if any) from the measured reading. The basic equation with a sample calculation is as follows:

$$FS = RA + AF + CL - AG$$

Where FS = Field Strength	CL = Cable Attenuation Factor (Cable Loss)
RA = Reading Amplitude	AG = Amplifier Gain
AF = Antenna Factor	

RADIATION LIMIT

For unintentional device, according to § 15.209(a), except for Class A digital devices, the field strength of radiated emissions from unintentional radiators at a distance of 3 meters shall not exceed the following values:

Frequency (MHz)	Distance (Meters)	Radiated (dBµV/m)	Radiated (µV/m)
30-88	3	40.0	100
88-216	3	43.5	150
216-960	3	46.0	200
Above 960	3	54.0	500

For intentional device, according to § 15.209(a), the general requirement of field strength of radiated emissions from intentional radiators at a distance of 3 meters shall not exceed the above table.

TEST PROCEDURE

1. The EUT is placed on a turntable, which is 0.8m above ground plane below 1GHz and 1.5m above ground plane above 1GHz.
2. The turntable shall be rotated for 360 degrees to determine the position of maximum emission level.
3. EUT is set 3m away from the receiving antenna, which is varied from 1m to 4m to find out the highest emissions.
4. For the radiated emission test above 1GHz: Place the measurement antenna away from each area of the EUT determined to be a source of emissions at the specified measurement distance, while keeping the measurement antenna aimed at the source of emissions at each frequency of significant emissions, with polarization oriented for maximum response. The measurement antenna may have to be higher or lower than the EUT, depending on the radiation pattern of the emission and staying aimed at the emission source for receiving the maximum signal. The final measurement antenna elevation shall be that which maximizes the emissions. The measurement antenna elevation for maximum emissions shall be restricted to a range of heights of from 1 m to 4 m above the ground or reference ground plane.
5. Maximum procedure was performed on the six highest emissions to ensure EUT compliance.
6. And also, each emission was to be maximized by changing the polarization of receiving antenna both horizontal and vertical.
7. Repeat above procedures until the measurements for all frequencies are complete.
8. Based on the Frequency Generator in the device include 16MHz. The test frequency range from 9KHz to 25GHz per FCC PART 15.33(a).

Note:

Three axes are chosen for pretest, the Y axis is the worst mode for final test.
For battery operated equipment, the equipment tests shall be performed using a new battery.

TEST RESULTS

All the test modes (TM1, TM2, TM3 and TM4) completed for test. The worst case of Radiated Emission is TM1; the test data of this mode was reported.

Below 1GHz Test Results:

SWEEP TABLE: "test (30M-1G)"

Short Description:		Field Strength			
Start	Stop	Detector	Meas. Time	IF Bandw.	Transducer
Frequency	Frequency				
30.0 MHz	1.0 GHz	MaxPeak	300.0 ms	120 kHz	JB1

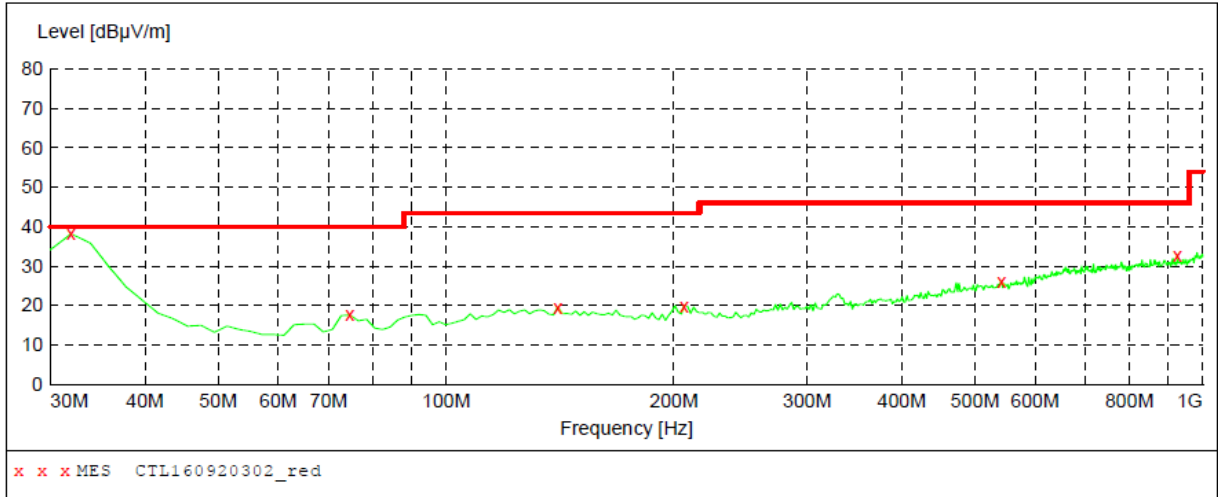

MEASUREMENT RESULT: "CTL160920302_red"

9/20/2016 9:38AM

Frequency MHz	Level dBµV/m	Transd dB	Limit dBµV/m	Margin dB	Det.	Height cm	Azimuth deg	Polarization
31.940000	38.20	19.2	40.0	1.8	---	0.0	0.00	VERTICAL
74.620000	17.60	8.3	40.0	22.4	---	0.0	0.00	VERTICAL
140.580000	19.60	14.3	43.5	23.9	---	0.0	0.00	VERTICAL
206.540000	19.90	14.1	43.5	23.6	---	0.0	0.00	VERTICAL
542.160000	26.20	20.7	46.0	19.8	---	0.0	0.00	VERTICAL
926.280000	32.80	26.2	46.0	13.2	---	0.0	0.00	VERTICAL

Remark:

- (1) Measuring frequencies from 9 KHz to the 1 GHz, Radiated emission test from 9KHz to 30MHz was verified, and no any emission was found except system noise floor.
- (2) * denotes emission frequency which appearing within the Restricted Bands specified in provision of 15.205, then the general radiated emission limits in 15.209 apply.
- (3) The IF bandwidth of EMI Test Receiver between 30MHz to 1GHz was 120KHz, 1 MHz for measuring above 1 GHz, below 30MHz was 10KHz.

SWEEP TABLE: "test (30M-1G)"

Short Description:		Field Strength			
Start	Stop	Detector	Meas. Time	IF Bandw.	Transducer
Frequency	Frequency				
30.0 MHz	1.0 GHz	MaxPeak	300.0 ms	120 kHz	JB1

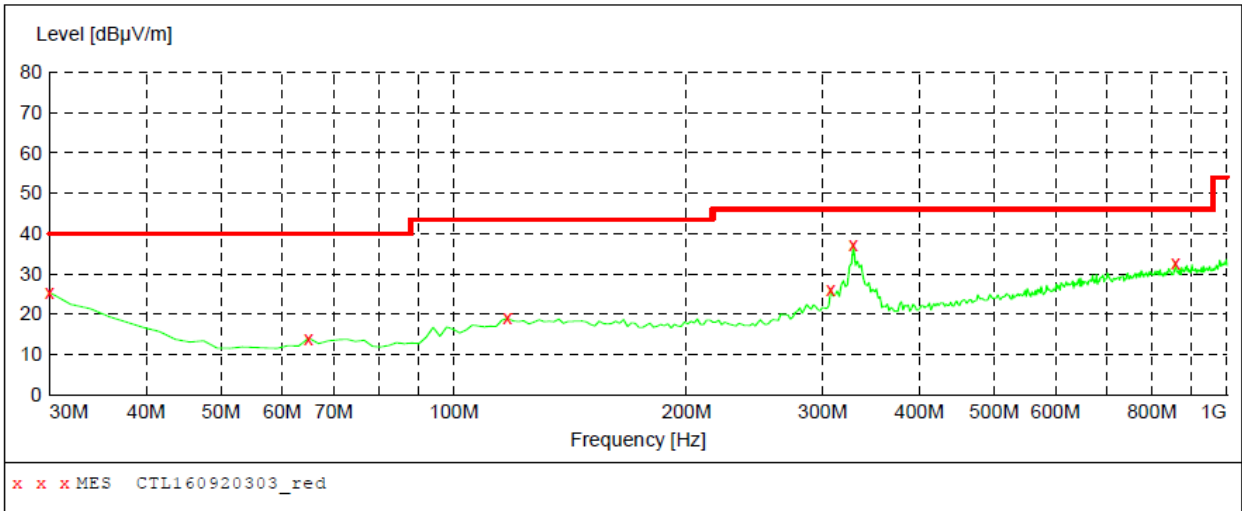

MEASUREMENT RESULT: "CTL160920303_red"

9/20/2016 9:40AM

Frequency MHz	Level dBµV/m	Transd dB	Limit dBµV/m	Margin dB	Det.	Height cm	Azimuth deg	Polarization
30.000000	25.30	20.8	40.0	14.7	---	0.0	0.00	HORIZONTAL
64.920000	14.00	8.1	40.0	26.0	---	0.0	0.00	HORIZONTAL
117.300000	19.00	14.7	43.5	24.5	---	0.0	0.00	HORIZONTAL
307.420000	26.20	15.4	46.0	19.8	---	0.0	0.00	HORIZONTAL
328.760000	37.40	16.0	46.0	8.6	---	0.0	0.00	HORIZONTAL
858.380000	32.80	25.3	46.0	13.2	---	0.0	0.00	HORIZONTAL

Remark:

- (1) Measuring frequencies from 9 KHz to the 1 GHz, Radiated emission test from 9KHz to 30MHz was verified, and no any emission was found except system noise floor.
- (2) * denotes emission frequency which appearing within the Restricted Bands specified in provision of 15.205, then the general radiated emission limits in 15.209 apply.
- (3) The IF bandwidth of EMI Test Receiver between 30MHz to 1GHz was 120KHz, 1 MHz for measuring above 1 GHz, below 30MHz was 10KHz.

Above 1 GHz Test Results:

Note: H and V polarity all have been tested , only worse case vertical polarity is reported

Frequency	Emission		Limit	Margin	Raw	Antenna Factor	Cable	Pre-amplifier	Correction
(MHz)	Level		(dBuV/m)	(dB)	Value	(dB/m)	Factor	(dB)	Factor
	(dBuV/m)				(dBuV)		(dB)		(dB/m)
2402.00	91.81	PK	114	22.19	93.77	28.78	4.61	35.36	-1.96
2402.00	82.76	AV	94	11.24	84.72	28.78	4.61	35.36	-1.96
2390.00	63.54	PK	74	10.46	65.58	28.72	4.60	35.36	-2.04
2390.00	45.42	AV	54	8.58	47.46	28.72	4.60	35.36	-2.04
2400.00	68.03	PK	74	5.97	70.00	28.78	4.61	35.36	-1.97
2400.00	49.17	AV	54	4.83	51.14	28.78	4.61	35.36	-1.97
4804.00	66.75	PK	74	7.25	62.24	33.49	6.91	35.89	4.51
4804.00	47.58	AV	54	6.42	43.07	33.49	6.91	35.89	4.51
6005.00	63.46	PK	74	10.54	55.33	35.12	7.60	34.59	8.13
6005.00	46.95	AV	54	7.05	38.82	35.12	7.60	34.59	8.13
7206.00	61.03	PK	74	12.97	49.92	36.95	9.18	35.03	11.11
7206.00	45.44	AV	54	8.56	34.33	36.95	9.18	35.03	11.11

Frequency	Emission		Limit	Margin	Raw	Antenna Factor	Cable	Pre-amplifier	Correction
(MHz)	Level		(dBuV/m)	(dB)	Value	(dB/m)	Factor	(dB)	Factor
	(dBuV/m)				(dBuV)		(dB)		(dB/m)
2440.00	90.48	PK	114	23.52	92.34	28.85	4.65	35.37	-1.86
2440.00	81.29	AV	94	12.71	83.15	28.85	4.65	35.37	-1.86
3200.00	63.42	PK	74	10.58	62.06	31.24	5.47	35.35	1.36
3200.00	46.04	AV	54	7.96	44.68	31.24	5.47	35.35	1.36
3641.00	63.49	PK	74	10.51	60.27	32.27	5.99	35.05	3.22
3641.00	47.11	AV	54	6.89	43.89	32.27	5.99	35.05	3.22
4880.00	67.05	PK	74	6.95	60.69	33.60	6.95	34.19	6.36
4880.00	48.96	AV	54	5.04	42.60	33.60	6.95	34.19	6.36
6133.00	63.02	PK	74	10.98	54.69	35.20	7.79	34.66	8.33
6133.00	44.83	AV	54	9.17	36.50	35.20	7.79	34.66	8.33
7320.00	65.07	PK	74	8.93	53.38	37.46	9.23	35.00	11.69
7320.00	46.31	AV	54	7.69	34.62	37.46	9.23	35.00	11.69

Frequency	Emission		Limit	Margin	Raw	Antenna Factor	Cable	Pre-amplifier	Correction
(MHz)	Level		(dBuV/m)	(dB)	Value	(dB/m)	Factor	(dB)	Factor
	(dBuV/m)				(dBuV)		(dB)		(dB/m)
2480.00	90.95	PK	114	23.05	92.70	28.92	4.70	35.38	-1.75
2480.00	81.47	AV	94	12.53	83.22	28.92	4.70	35.38	-1.75
2483.50	60.38	PK	74	13.62	62.12	28.93	4.70	35.38	-1.74
2483.50	48.72	AV	54	5.28	50.46	28.93	4.70	35.38	-1.74
3720.00	63.01	PK	74	10.99	59.81	32.77	6.08	35.65	3.20
3720.00	44.89	AV	54	9.11	41.69	32.77	6.08	35.65	3.20
4960.00	68.38	PK	74	5.62	61.68	33.84	7.00	34.14	6.70
4960.00	49.05	AV	54	4.95	42.35	33.84	7.00	34.14	6.70
6200.00	60.74	PK	74	13.26	52.34	35.19	7.90	34.69	8.40
6200.00	43.01	AV	54	10.99	34.61	35.19	7.90	34.69	8.40
7440.00	66.84	PK	74	7.16	54.89	37.64	9.28	34.97	11.95
7440.00	46.02	AV	54	7.98	34.07	37.64	9.28	34.97	11.95

Note: above 10GHz up to 25GHz was verified, and no any emission was found except system noise floor.

Remark: Fundamental Emissions: RBW=3MHz VBW =3MHz peak detector for PK value, RMS detector for AV value



4.3. Occupied Bandwidth Measurement

Measurement Procedure

1. Set EUT as normal operation.
2. $RBW \geq 1\%$ of the 20 dB bandwidth, $VBW \geq RBW$.
3. The useful radiated emission from the EUT was detected by the spectrum analyser with peak detector.

Measurement Results

2402MHz



20dB Bandwidth: 1210 KHz

2440MHz



20dB Bandwidth: 1211KHz

2480MHz



20dB Bandwidth: 1175 KHz



5. Antenna Requirement

Standard Applicable

For intentional device, according to FCC 47 CFR Section 15.203, an intentional radiator shall be designed to ensure that no antenna other than that furnished by the responsible party shall be used with the device.

And according to FCC 47 CFR Section 15.247 (c), if transmitting antennas of directional gain greater than 6dBi are used, the power shall be reduced by the amount in dB that the directional gain of the antenna exceeds 6dBi.

Refer to statement below for compliance.

The manufacturer may design the unit so that the user can replace a broken antenna, but the use of a standard antenna jack or electrical connector is prohibited. Further, this requirement does not apply to intentional radiators that must be professionally installed.

Antenna Connected Construction

The antenna used in this product is an internal Antenna, The directional gains of antenna used for transmitting is 2 dBi.



6. Test Setup Photos of the EUT

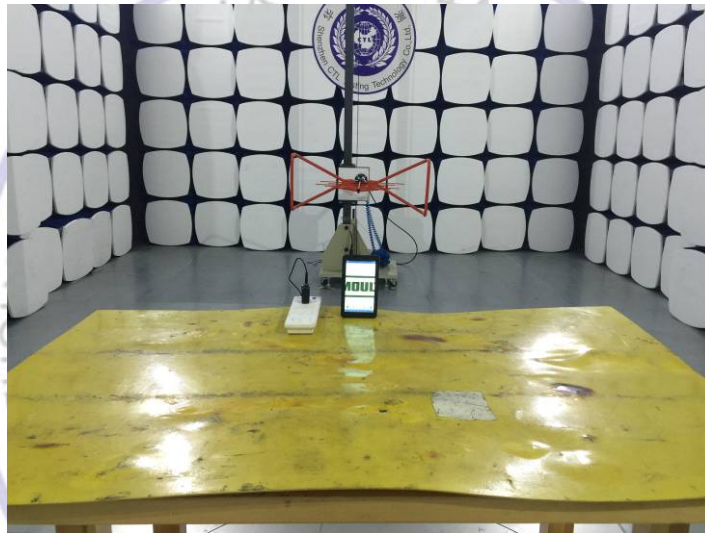



7. External and Internal Photos of the EUT

External Photos of EUT







Internal Photos of EUT



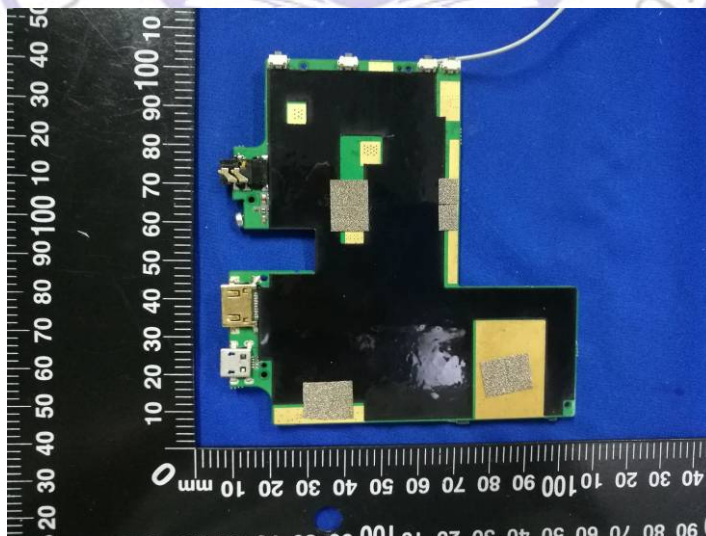
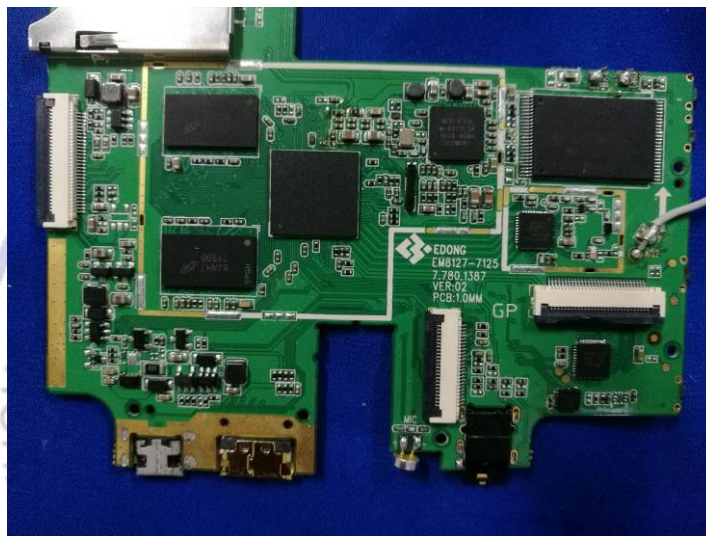
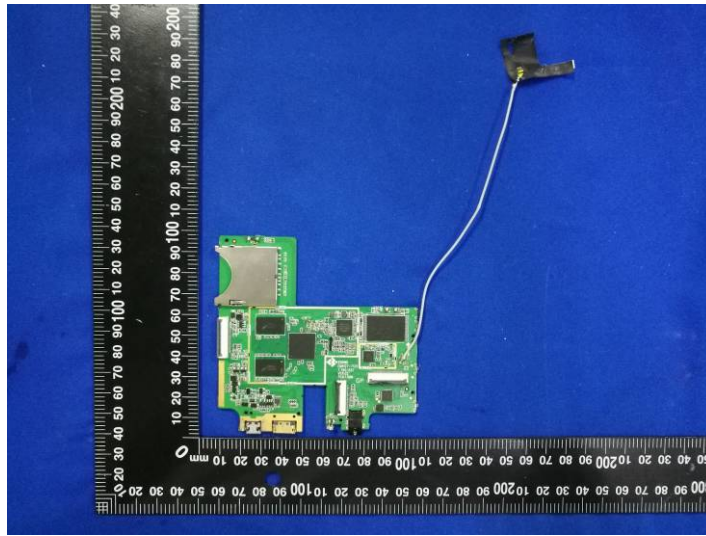

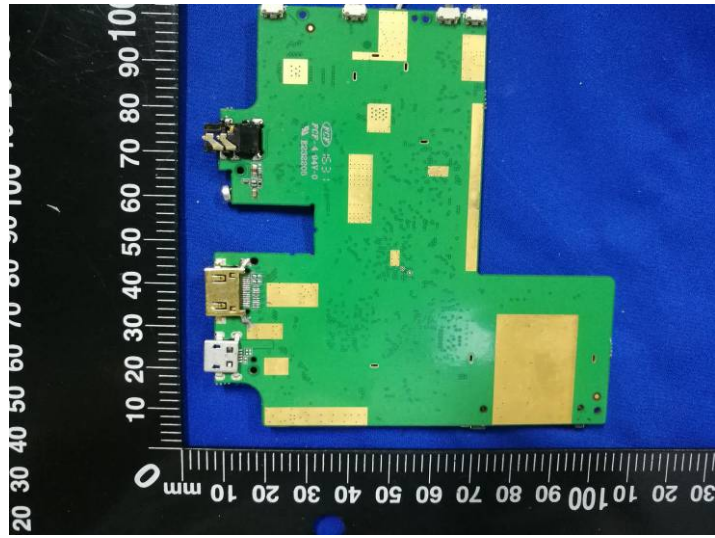

.....End of Report.....

