



Excellence in Compliance Solutions

## **Certification Test Report**

**FCC ID: 2AJPY-MDLTN00**

**FCC Rule Part: 15.247**

**ACS Report Number: 16-3078.W03.1A**

**Manufacturer: Smart Pet Technologies, LLC  
Model: SPT001M**

Test Begin Date: December 14, 2016

Test End Date: December 16, 2016

Report Issue Date: December 28, 2016



FOR THE SCOPE OF ACCREDITATION UNDER LAB Code AT-1921

This report must not be used by the client to claim product certification, approval, or endorsement by ANAB, ANSI, or any agency of the Federal Government.

**Prepared by:**

**Mario deAranzeta  
Senior Wireless Test Engineer  
Advanced Compliance Solutions, Inc.**

**Reviewed by:**

**Ryan McGann  
Wireless Program Manager  
Advanced Compliance Solutions, Inc.**

This test report shall not be reproduced except in full. This report may be reproduced in part with prior written consent of ACS, Inc. The results contained in this report are representative of the sample(s) submitted for evaluation.

**This report contains 21 pages**

# TABLE OF CONTENTS

<b>1</b>	<b>GENERAL</b> .....	<b>3</b>
1.1	PURPOSE.....	3
1.2	PRODUCT DESCRIPTION.....	3
1.3	TEST METHODOLOGY AND CONSIDERATIONS .....	3
<b>2</b>	<b>TEST FACILITIES</b> .....	<b>4</b>
2.1	LOCATION .....	4
2.2	LABORATORY ACCREDITATIONS/RECOGNITIONS/CERTIFICATIONS .....	4
2.3	RADIATED EMISSIONS TEST SITE DESCRIPTION .....	5
2.3.1	<i>Semi-Anechoic Chamber Test Site</i> .....	5
2.4	CONDUCTED EMISSIONS TEST SITE DESCRIPTION .....	6
<b>3</b>	<b>APPLICABLE STANDARD REFERENCES</b> .....	<b>6</b>
<b>4</b>	<b>LIST OF TEST EQUIPMENT</b> .....	<b>7</b>
<b>5</b>	<b>SUPPORT EQUIPMENT</b> .....	<b>8</b>
<b>6</b>	<b>EQUIPMENT UNDER TEST SETUP BLOCK DIAGRAM</b> .....	<b>8</b>
<b>7</b>	<b>SUMMARY OF TESTS</b> .....	<b>9</b>
7.1	ANTENNA REQUIREMENT – FCC 15.203 .....	9
7.2	POWER LINE CONDUCTED EMISSIONS – FCC 15.207 .....	9
7.3	6dB BANDWIDTH – FCC 15.247(A)(2).....	10
7.3.1	<i>Measurement Procedure</i> .....	10
7.3.2	<i>Measurement Results</i> .....	10
7.4	FUNDAMENTAL EMISSION OUTPUT POWER – FCC 15.247(B)(3).....	12
7.4.1	<i>Measurement Procedure</i> .....	12
7.4.2	<i>Measurement Results</i> .....	12
7.5	EMISSION LEVELS – FCC 15.247(D), 15.205, 15.209 .....	14
7.5.1	<i>Emissions into Non-restricted Frequency Bands</i> .....	14
7.5.1.1	<i>Measurement Procedure</i> .....	14
7.5.1.2	<i>Measurement Results</i> .....	14
7.5.2	<i>Emissions into Restricted Frequency Bands</i> .....	17
7.5.2.1	<i>Measurement Procedure</i> .....	17
7.5.2.2	<i>Duty Cycle Correction</i> .....	17
7.5.2.3	<i>Measurement Results</i> .....	17
7.5.2.4	<i>Sample Calculation:</i> .....	18
7.6	MAXIMUM POWER SPECTRAL DENSITY IN THE FUNDAMENTAL EMISSION – FCC 15.247(E) .....	19
7.6.1	<i>Measurement Procedure</i> .....	19
7.6.2	<i>Measurement Results</i> .....	19
<b>8</b>	<b>CONCLUSION</b> .....	<b>21</b>

## 1 GENERAL

### 1.1 Purpose

The purpose of this report is to demonstrate compliance with Part 15 Subpart C of the FCC's Code of Federal Regulations Certification.

### 1.2 Product Description

The SPT001M Module unit (Collar) - FCC ID: 2AJPY-MDLTN00 - is part of the AKC's LINK system that provides location and activity monitoring for dogs.

The EUT contains the following Radios:

BLE Chip Model: BCM20735 manufactured by Cypress Semiconductor

WiFi Chip Model: BCM43364 Manufactured by Cypress Semiconductor (used in receive only).

Cellular Module Model: SARA-U280 manufactured by Ublox – FCC ID: XPYSARAU280

Technical Information:

Detail	Description
Frequency Range	2402 to 2480 MHz
Number of Channels	3 advertising and 37 data
Modulation Format	GFSK (F1D)
Data Rates	To 1 Mbps
Number of Inputs/Outputs	1 RF output to an integral antenna
Operating Voltage	3.7 Vdc
Antenna Type / Gain	Copper Wire / -10.4dBi Peak

Manufacturer Information:

Smart Pet Technologies, LLC  
1 Landmark Square  
Stamford, Connecticut 06901

EUT Serial Numbers: DVT

Test Sample Condition: The test samples were provided in good working order with no visible defects.

### 1.3 Test Methodology and Considerations

For radiated emissions three orientations of the EUT were evaluated to determine the worst case. The worst case orientation was determined to be the Y orientation.

The EUT is a battery operated dog worn device therefore AC power line conducted emissions testing was not performed.

The manufacturer provided test firmware to exercise the EUT.

For RF Conducted measurements at the antenna port, the EUT was modified with a temporary 50 ohm connector and coupled to the measurement equipment with suitable attenuation.

The EUT was programmed for a continuously modulated signal with random data on each channel investigated.

## **2 TEST FACILITIES**

### **2.1 Location**

The radiated and conducted emissions test sites are located at the following address:

Advanced Compliance Solutions  
2320 Presidential Drive, Suite 101  
Durham, NC 27703  
Phone: (919) 381-4235

### **2.2 Laboratory Accreditations/Recognitions/Certifications**

ACS is accredited to ISO/IEC 17025 by ANSI-ASQ National Accreditation Board under their ANAB program and has been issued certificate number AT-1921 in recognition of this accreditation. Unless otherwise specified, all test methods described within this report are covered under the ISO/IEC 17025 scope of accreditation.

**2.3 Radiated Emissions Test Site Description**

**2.3.1 Semi-Anechoic Chamber Test Site**

The Semi-Anechoic Chamber Test Site consists of a 18' x 28' x 18' shielded enclosure. The chamber is lined with Samwha Electronics Co. LTD Ferrite Absorber, model number SFA300 (HSN-1). The ferrite tile is 10cm x 10 cm and weighs approximately 1.4lbs. These tiles are mounted on steel panels and installed directly on the inner walls of the chamber. On top of the ferrite tiles is DMAS HT-45 (Dutch Microwave Absorber Solutions) hybrid absorber on all walls except the wall behind the antenna mast which has a shorter DMAS HT-25 absorber.

The turntable is 1.50m in diameter and is located 150cm from the back wall of the chamber. The chamber is grounded via 1 - 8' copper ground rod, installed at the center of the back wall, it is bound to the ground plane using short #6 copper wire. The turntable is an aluminum, flush mounted table installed in an all steel frame. The table is remotely operated from inside the control room located 25' from the turntable. The turntable is electrically bonded to the surrounding ground plane via steel fingers installed on the edge of the turn table. The steel fingers make constant contact with the ground plane.

Behind the turntable is a 2' x 6' x 1.5' deep shielded pit used for support equipment if necessary. The pit is equipped with 2 - 4" PVC chase from the turntable to the pit that allow for cabling to the EUT if necessary. The underside of the turntable can be accessed from the pit so cables can be supplied to the EUT from the pit.

A diagram of the Semi-Anechoic Chamber Test Site is shown in Figure 2.3-1 below:

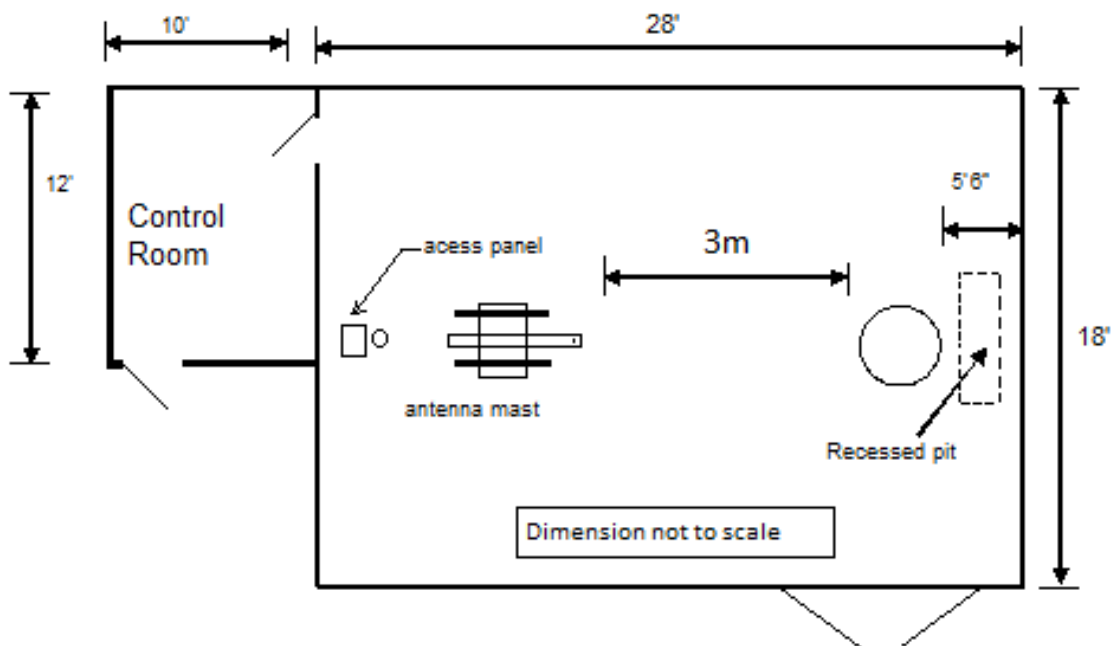

**Figure 2.3-1: Semi-Anechoic Chamber Test Site**

## 2.4 Conducted Emissions Test Site Description

The AC mains conducted EMI site is located in the main EMC lab. It consists of an 8' x 10' sheet galvanized steel horizontal ground reference plane (GRP) bonded every 6" to an 8' X 8' aluminum vertical ground plane.

A diagram of the room is shown below in figure 2.4-1:

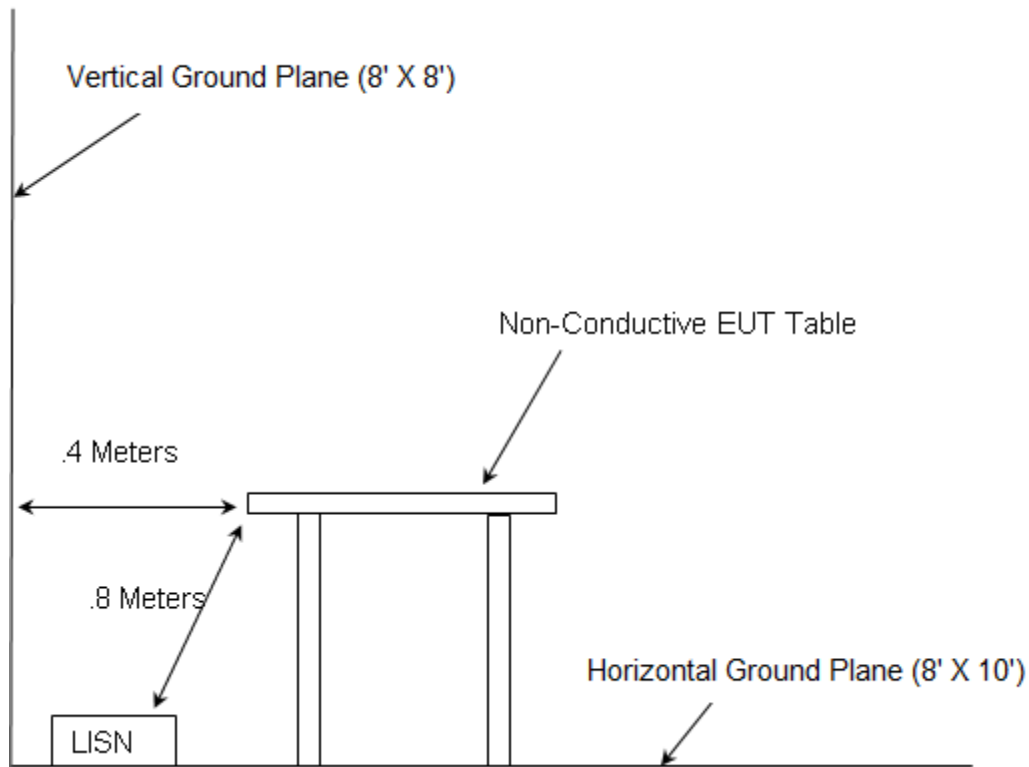

Figure 2.4-1: AC Mains Conducted EMI Site

## 3 APPLICABLE STANDARD REFERENCES

The following standards were used:

- ❖ ANSI C63.10-2013: American National Standard of Procedures for Compliance Testing of Unlicensed Wireless Devices
- ❖ US Code of Federal Regulations (CFR): Title 47, Part 2, Subpart J: Equipment Authorization Procedures, 2015
- ❖ US Code of Federal Regulations (CFR): Title 47, Part 15, Subpart C: Radio Frequency Devices, Intentional Radiators, 2015
- ❖ FCC KDB 558074 D01 DTS Meas Guidance v03r05 - Guidance for Performing Compliance Measurements on Digital Transmission Systems (DTS) Operating Under §15.247, April 8, 2016

#### 4 LIST OF TEST EQUIPMENT

The calibration interval of test equipment is annually or the manufacturer's recommendations. Where the calibration interval deviates from the annual cycle based on the instrument manufacturer's recommendations, it shall be stated below.

**Table 4-1: Test Equipment**

Asset ID	Manufacturer	Model #	Equipment Type	Serial #	Last Calibration Date	Calibration Due Date
277	EMCO	93146	Antennas	9904-5199	9/12/2016	9/12/2018
626	EMCO	3110B	Antennas	9411-1945	2/29/2016	2/28/2017
3002	Rohde & Schwarz	ESU40	Receiver	100346	1/8/2016	1/8/2017
3006	Rohde & Schwarz	TS-PR18	Amplifiers	122006	6/29/2015	12/29/2016
3007	Rohde & Schwarz	TS-PR26	Amplifiers	100051	6/29/2015	12/29/2016
3012	Rohde & Schwarz	EMC32-EB	Software	100731	8/2/2016	2/2/2017
3016	Fei Teng Wireless Technology	HA-07M18G-NF	Antennas	2013120203	1/26/2016	1/26/2018
3027	Micro-Tronics	BRM50702	Filter	175	12/21/2015	12/21/2016
3031	Hasco, Inc.	HLL335-S1-S1-96	Cables	3074	12/30/2015	12/30/2016
3033	Hasco, Inc.	HLL142-S1-S1-36	Cables	1435	1/7/2016	1/7/2017
3038	Florida RF Labs	NMSE-290AW-60.0-NMSE	Cable Set	1448	12/22/2015	12/22/2016
3039	Florida RF Labs	NMSE-290AW-396.0-NMSE	Cable Set	1447	12/22/2015	12/22/2016
3042	Aeroflex Inmet	18N10W-10	Cable Set	1444	1/8/2016	1/8/2017
3055	Rohde & Schwarz	3005	Cables	3055	12/30/2015	12/30/2016
3057	Advanced Technical Materials	42-441-6/BR	Antennas	R110602	NCR	NCR
3085	Rohde & Schwarz	FSW43	Spectrum Analyzer	103997	8/9/2016	8/9/2017

**NCR = No Calibration Required**

**Firmware Version: ESU40 is 4.73 SP1**

**Software Version: EMC32-B is 9.15**

**5 SUPPORT EQUIPMENT**

**Table 5-1: EUT Description**

Item #	Type Device	Manufacturer or Responsible Party	Model/Part #	Serial #
1	EUT	Smart Pet Tech.	SPT001M	ACS # 1

**Table 5-2: Cable Description – Radiated Emissions**

Cable #	Cable Type	Length	Shield	Termination
None required.				

**6 EQUIPMENT UNDER TEST SETUP BLOCK DIAGRAM**

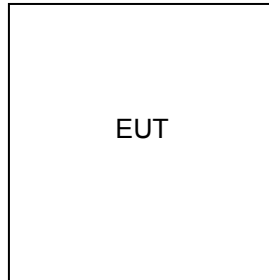

**Figure 6-1: Test Setup Block Diagram**

## **7 SUMMARY OF TESTS**

Along with the tabular data shown below, plots were taken of all signals deemed important enough to document.

### **7.1 Antenna Requirement – FCC 15.203**

The EUT utilizes a copper wire antenna. The antenna is integral to the device and cannot be removed or replaced by the end user. The peak gain of the antenna is -10.4dBi.

### **7.2 Power Line Conducted Emissions – FCC 15.207**

The EUT is a battery operated dog worn device therefore AC power line conducted emissions testing was not performed.

7.3 6dB Bandwidth – FCC 15.247(a)(2)

7.3.1 Measurement Procedure

The 6dB bandwidth was measured in accordance with the FCC KDB 558074 D01 DTS Meas Guidance v03r05. The Resolution Bandwidth (RBW) of the spectrum analyzer was set to 100 kHz. The Video Bandwidth (VBW) was set to ≥ 3 times the RBW. The trace was set to max hold with a peak detector active. The marker-delta function of the spectrum analyzer was utilized to determine the 6 dB bandwidth of the emission.

7.3.2 Measurement Results

Table 7.3.2-1: 6dB Bandwidth

Frequency (MHz)	6dB Bandwidth (kHz)
2402	857.110
2440	864.310
2480	830.720

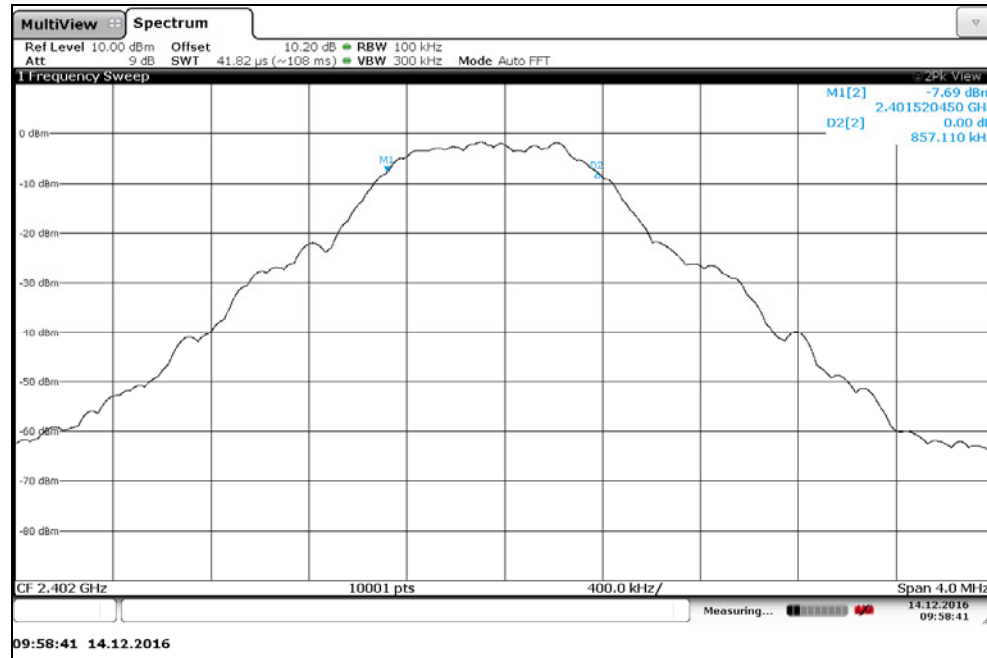

Figure 7.3.2-1: 6dB Bandwidth - LCH

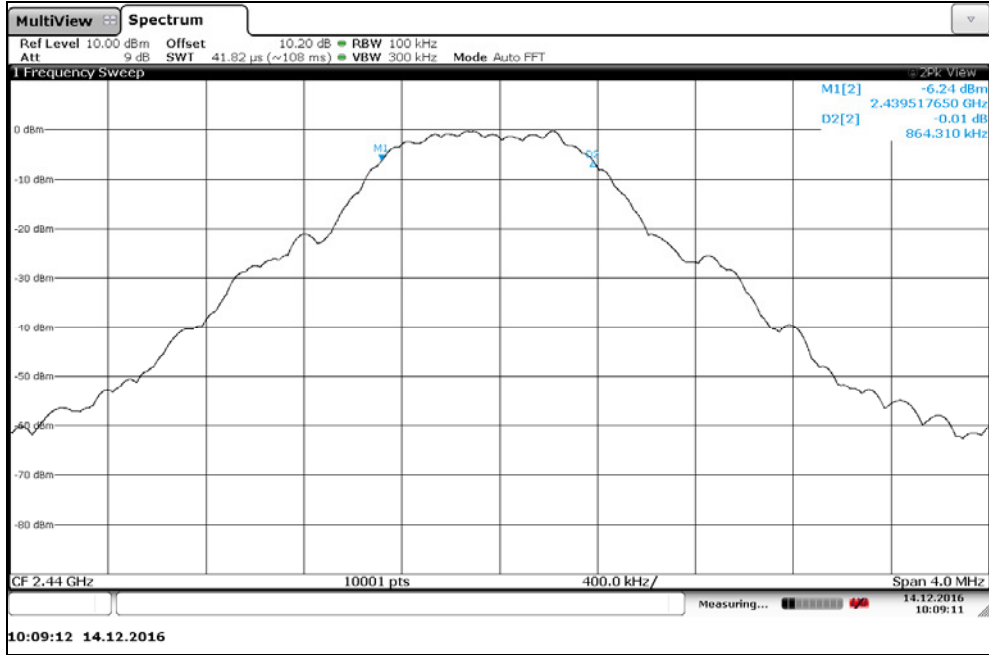

Figure 7.3.2-2: 6dB Bandwidth - MCH

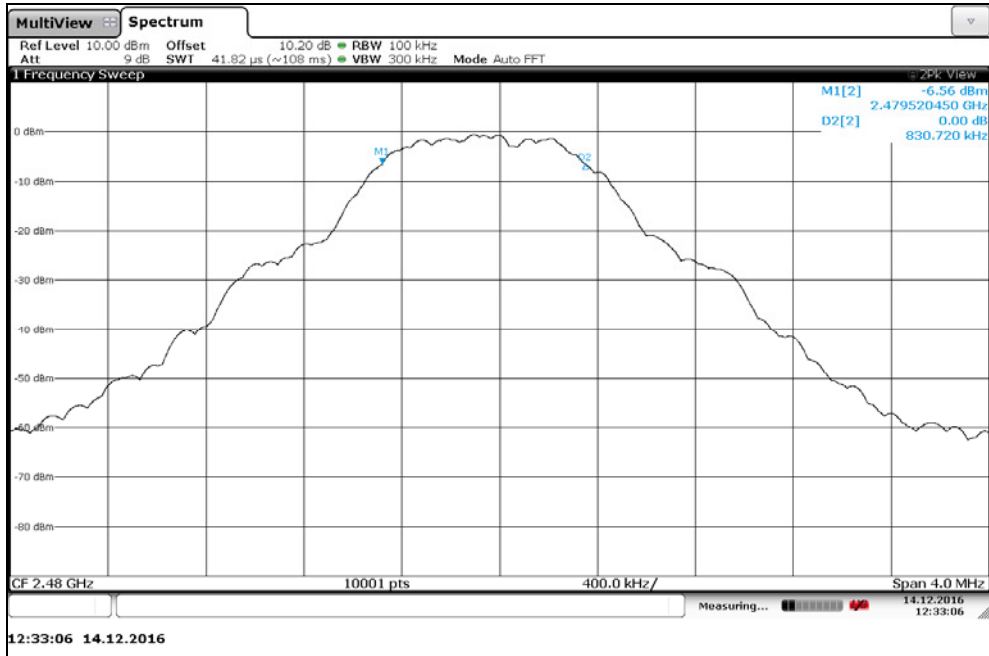

Figure 7.3.2-3: 6dB Bandwidth - HCH

**7.4 Fundamental Emission Output Power – FCC 15.247(b)(3)**

**7.4.1 Measurement Procedure**

The maximum peak conducted output power was measured in accordance with FCC KDB 558074 D01 DTS Measurement Guidance v03r05 utilizing the  $RBW \geq DTS\ BW$  method. The RF output of the equipment under test was directly connected to the input of the spectrum analyzer applying suitable attenuation.

**7.4.2 Measurement Results**

**Table 7.4.2-1: Maximum Peak Conducted Output Power**

Frequency (MHz)	Output Power (dBm)	Output Power (mW)
2402	0.71	1.17
2440	2.26	1.68
2480	1.87	1.54

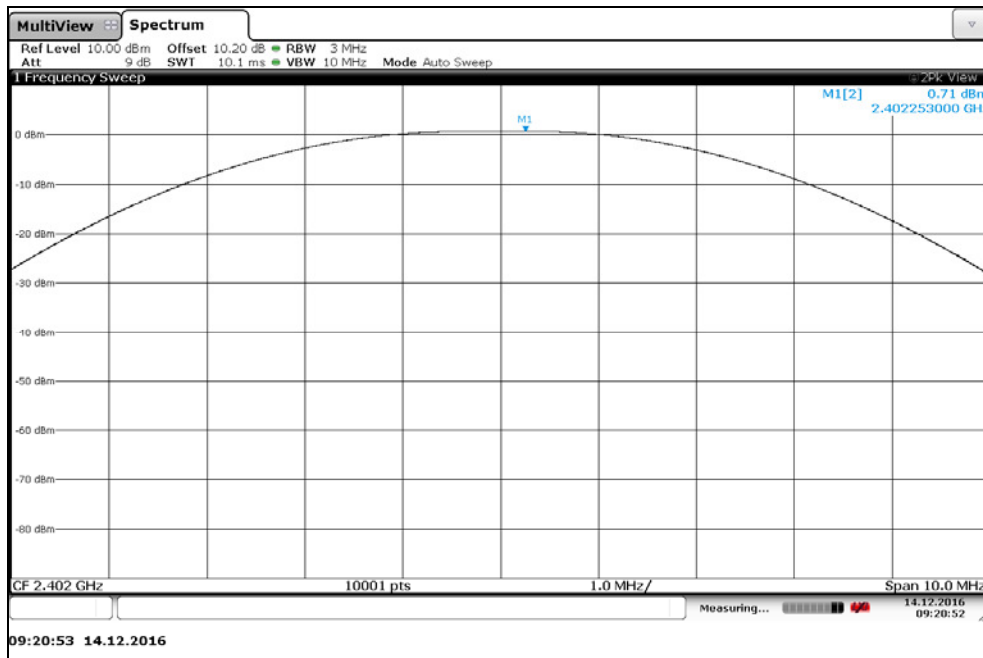

**Figure 7.4.2-1: Power Output - LCH**

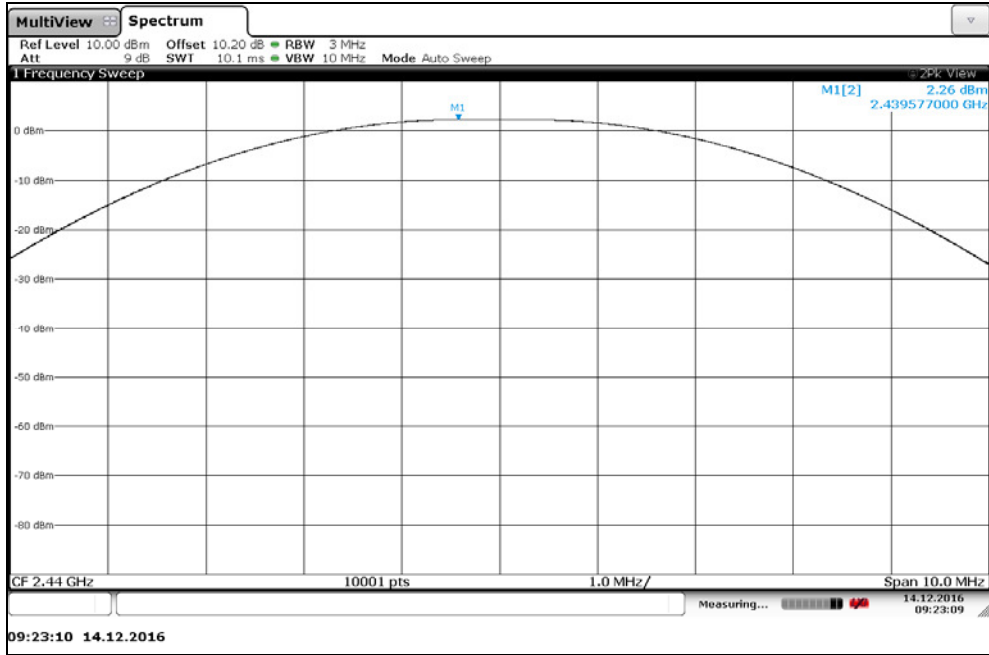

Figure 7.4.2-2: Power Output - MCH

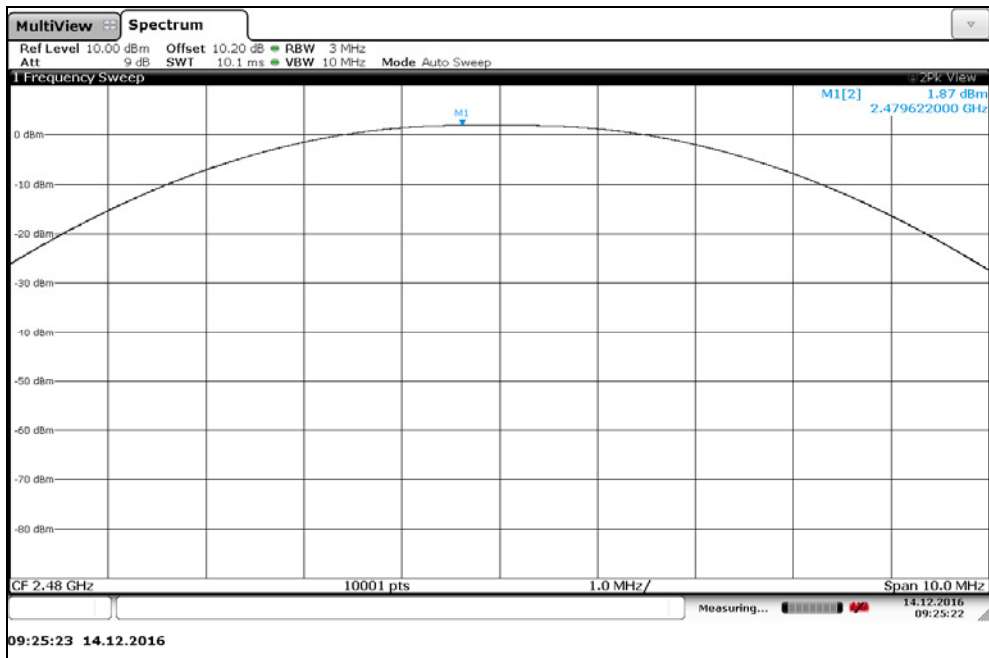

Figure 7.4.2-3: Power Output - HCH

**7.5 Emission Levels – FCC 15.247(d), 15.205, 15.209**

**7.5.1 Emissions into Non-restricted Frequency Bands**

**7.5.1.1 Measurement Procedure**

The unwanted emissions into non-restricted bands were measured conducted in accordance with FCC KDB 558074 D01 DTS Measurement Guidance v03r05. The RF output of the equipment under test was directly connected to the input of the spectrum analyzer applying suitable attenuation. The Resolution Bandwidth (RBW) of the spectrum analyzer was set to 100 kHz. The video bandwidth (VBW) was set to  $\geq 300$  kHz. Span was set to 1.5 times the DTS bandwidth. The trace was set to max hold with a peak detector active. The resulting spectrum analyzer peak level was used to determine the reference level with respect to the 20 dBc limit. The spectrum span was then adjusted for the measurement of spurious emissions from 30MHz to 25GHz, 10 times the highest fundamental frequency.

Band-edge compliance was determined using the conducted marker-delta method in which the radio frequency power that is produced by the EUT is at least 20 dB below that in the 100 kHz bandwidth within the band that contains the highest level of desired power.

**7.5.1.2 Measurement Results**

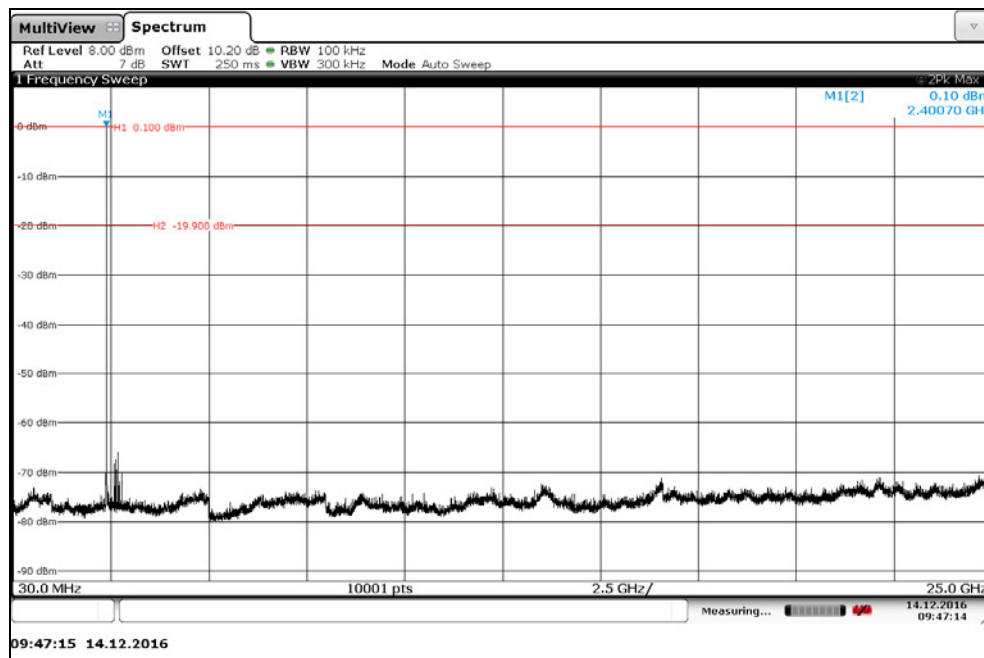

Figure 7.5.1.2-1: 30 MHz – 25 GHz – LCH

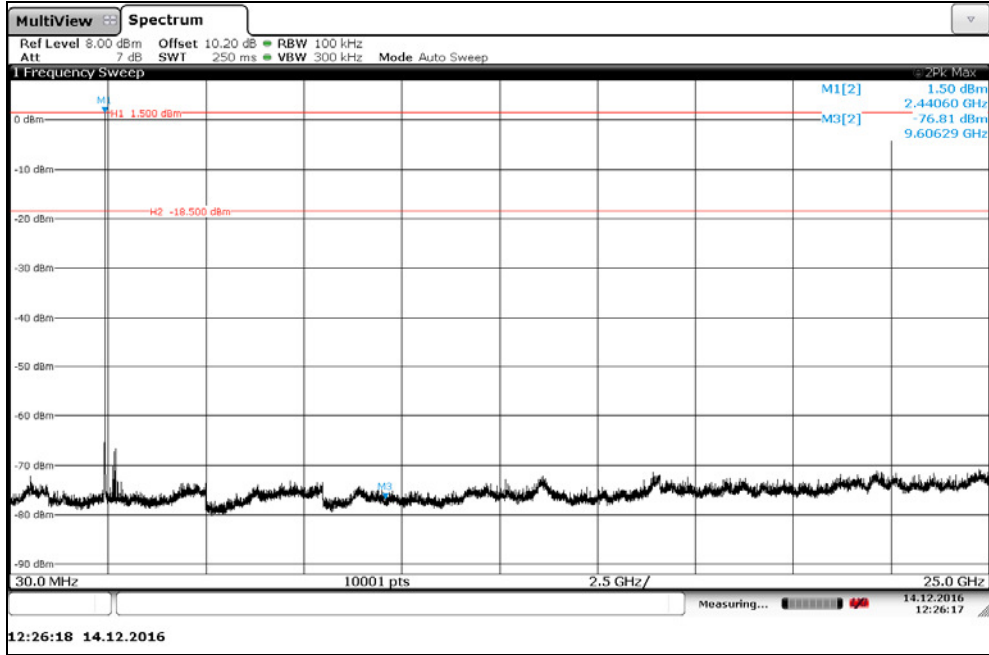

Figure 7.5.1.2-2: 30 MHz – 25 GHz – MCH

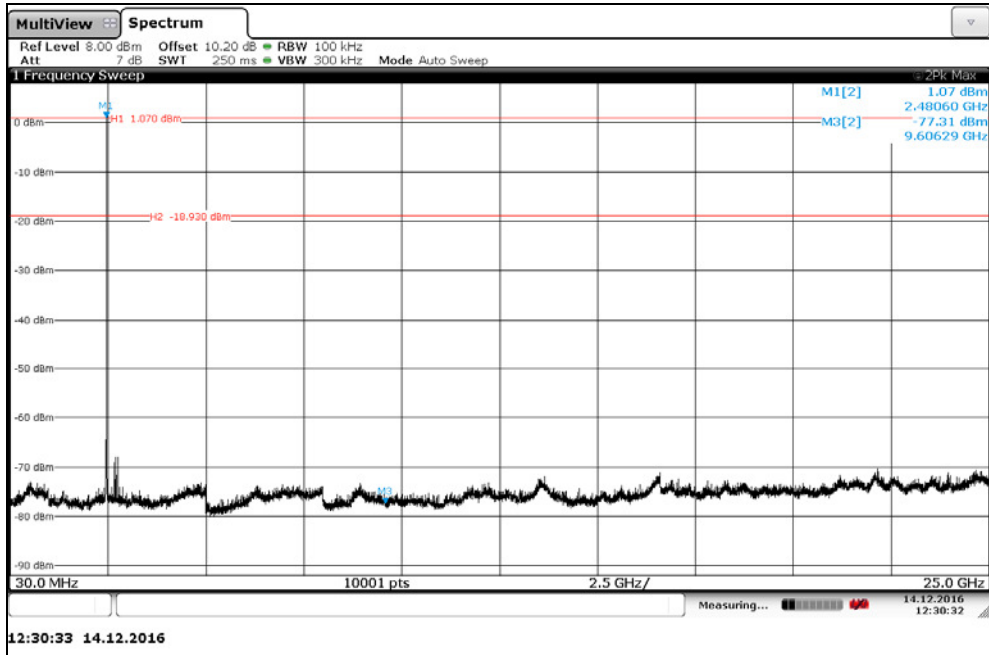

Figure 7.5.1.2-3: 30 MHz – 25 GHz – HCH

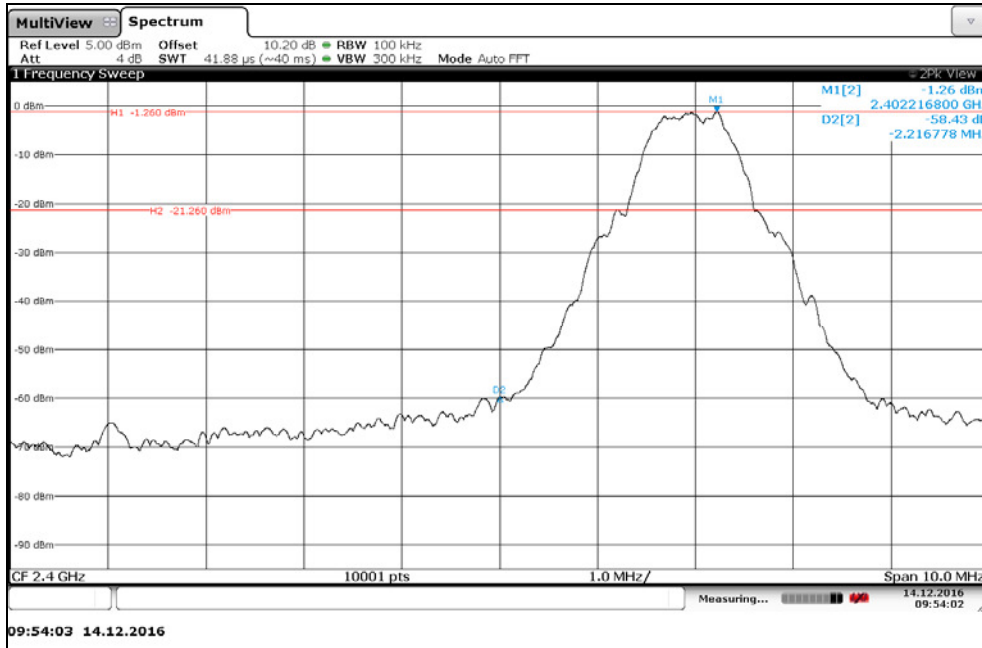

Figure 7.5.1.2-4: Lower Band-edge – LCH

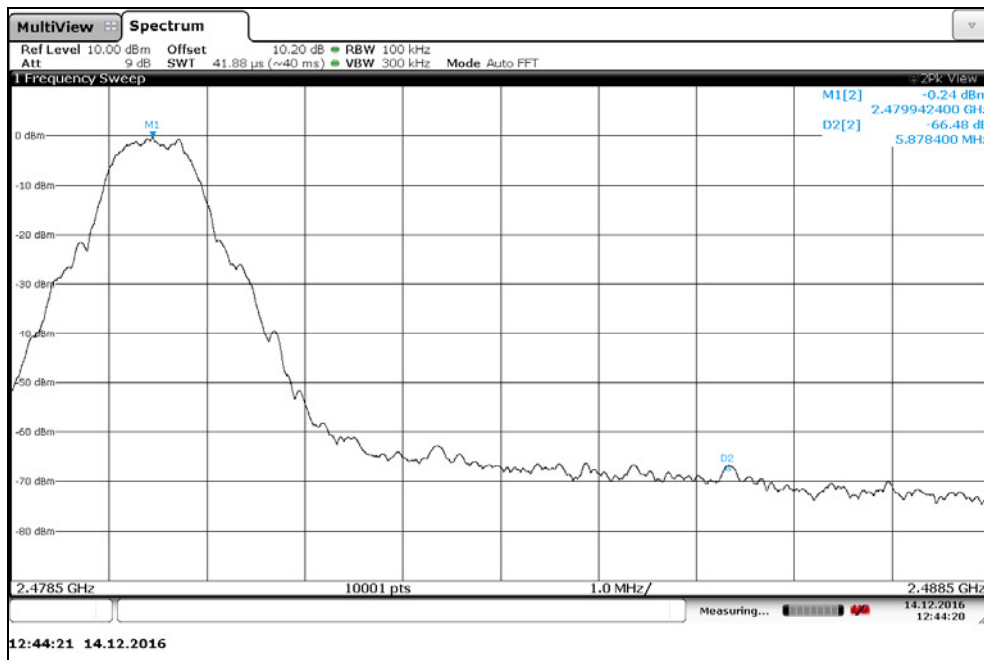

Figure 7.5.1.2-5: Upper Band-edge - HCH

**7.5.2 Emissions into Restricted Frequency Bands**

**7.5.2.1 Measurement Procedure**

The unwanted emissions into restricted bands were measured radiated over the frequency range of 30 MHz to 25GHz, 10 times the highest fundamental frequency.

The EUT was rotated through 360° and the receive antenna height was varied from 1m to 4m so that the maximum radiated emissions level would be detected. For frequencies below 1000MHz, quasi-peak measurements were made using a resolution bandwidth RBW of 120 kHz and a video bandwidth VBW of 300 kHz. For frequencies below 1000MHz, quasi-peak measurements were made using a RBW of 120 kHz and a VBW of 300 kHz. For frequencies above 1000MHz, peak and average measurements were made with RBW and VBW of 1 MHz and 3 MHz respectively.

Each emission found to be in a restricted band as defined by section 15.205, including any emission at the operational band-edge, was compared to the radiated emission limits as defined in section 15.209.

**7.5.2.2 Duty Cycle Correction**

There was no duty cycle correction factor required.

**7.5.2.3 Measurement Results**

**Table 7.5.2.3-1: Radiated Spurious Emissions Tabulated Data**

Frequency (MHz)	Measured Level (dBuV)		Antenna Polarity (H/V)	Turntable Position (o)	Antenna Height (cm)	Correction Factors (dB)	Corrected Level (dBuV/m)		Limit (dBuV/m)		Margin (dB)	
	Pk	Qpk/Av					Pk	Qpk/Av	Pk	Qpk/Av	Pk	Qpk/Av
<b>Low Channel</b>												
4804	44.50	30.10	H	60	100	6.16	50.66	36.26	74.0	54.0	23.3	17.7
4804	43.70	30.10	V	60	100	6.16	49.86	36.26	74.0	54.0	24.1	17.7
<b>Mid Channel</b>												
4880	43.70	30.20	H	250	105	6.17	49.87	36.37	74.0	54.0	24.1	17.6
4880	43.80	30.40	V	210	100	6.17	49.97	36.57	74.0	54.0	24.0	17.4
7320	42.00	28.70	H	135	105	9.00	51.00	37.70	74.0	54.0	23.0	16.3
7320	42.60	28.50	V	90	100	9.00	51.60	37.50	74.0	54.0	22.4	16.5
<b>High Power</b>												
4960	44.10	30.50	H	245	100	6.19	50.29	36.69	74.0	54.0	23.7	17.3
4960	44.40	31.00	V	190	100	6.19	50.59	37.19	74.0	54.0	23.4	16.8
7440	44.20	29.30	H	125	100	9.48	53.68	38.78	74.0	54.0	20.3	15.2
2483.5	51.20	37.20	H	0	100	-1.57	49.63	35.63	74.0	54.0	24.4	18.4
2483.5	50.00	37.20	V	0	100	-1.57	48.43	35.63	74.0	54.0	25.6	18.4

Note:

No significant emissions were noted in the restricted band 2310MHz to 2390MHz. Emissions above 7440MHz were attenuated below the noise floor of the instrumentation.

**7.5.2.4 Sample Calculation:**

$$R_C = R_U + CF_T$$

Where:

$CF_T$	=	Total Correction Factor (AF+CA+AG)-DC (Average Measurements Only)
$R_U$	=	Uncorrected Reading
$R_C$	=	Corrected Level
AF	=	Antenna Factor
CA	=	Cable Attenuation
AG	=	Amplifier Gain
DC	=	Duty Cycle Correction Factor

**Example Calculation: Peak**Corrected Level:  $44.50 + 6.16 = 50.66\text{dB}\mu\text{V}/\text{m}$ Margin:  $74\text{dB}\mu\text{V}/\text{m} - 50.66\text{dB}\mu\text{V}/\text{m} = 23.3\text{dB}$ **Example Calculation: Average**Corrected Level:  $30.10 + 6.16 - 0 = 36.26\text{dB}\mu\text{V}/\text{m}$ Margin:  $54\text{dB}\mu\text{V}/\text{m} - 36.26\text{dB}\mu\text{V}/\text{m} = 17.7\text{dB}$

**7.6 Maximum Power Spectral Density in the Fundamental Emission – FCC 15.247(e)**

**7.6.1 Measurement Procedure**

The power spectral density was measured in accordance with the FCC KDB 558074 D01 DTS Meas. Guidance v03r05 utilizing the PKPSD (peak PSD) method. The RF output of the equipment under test was directly connected to the input of the spectrum analyzer applying suitable attenuation. The Resolution Bandwidth (RBW) of the spectrum analyzer was set to 3 kHz. The Video Bandwidth (VBW) was set to 10 kHz. Span was set to 1.5 times the DTS bandwidth. The trace was set to max hold with a peak detector active.

**7.6.2 Measurement Results**

**Table 7.6.2-1: Peak Power Spectral Density**

Frequency (MHz)	PSD Level (dBm)	Limit (dBm)
2402	-13.95	8
2440	-12.25	8
2480	-12.66	8

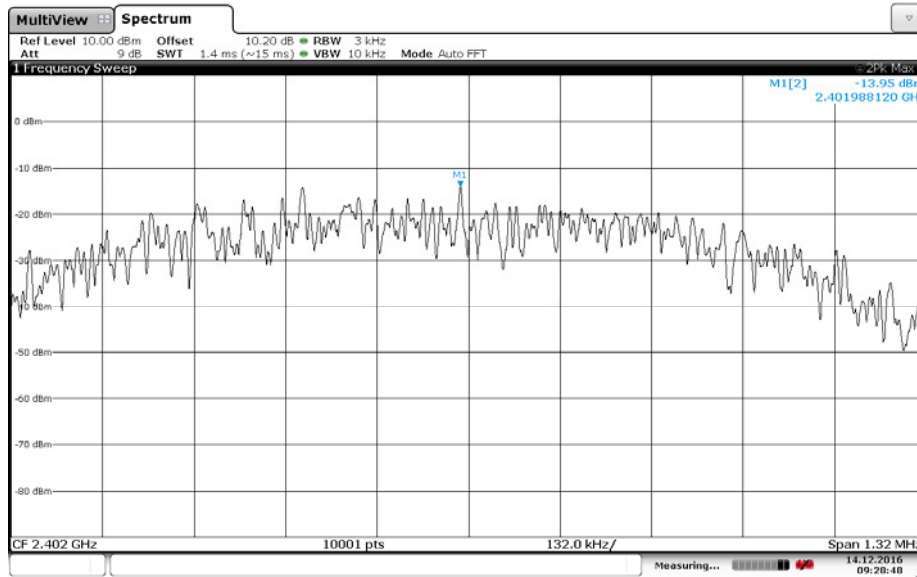

09:28:48 14.12.2016

**Figure 7.6.2-1: PSD Plot –LCH**

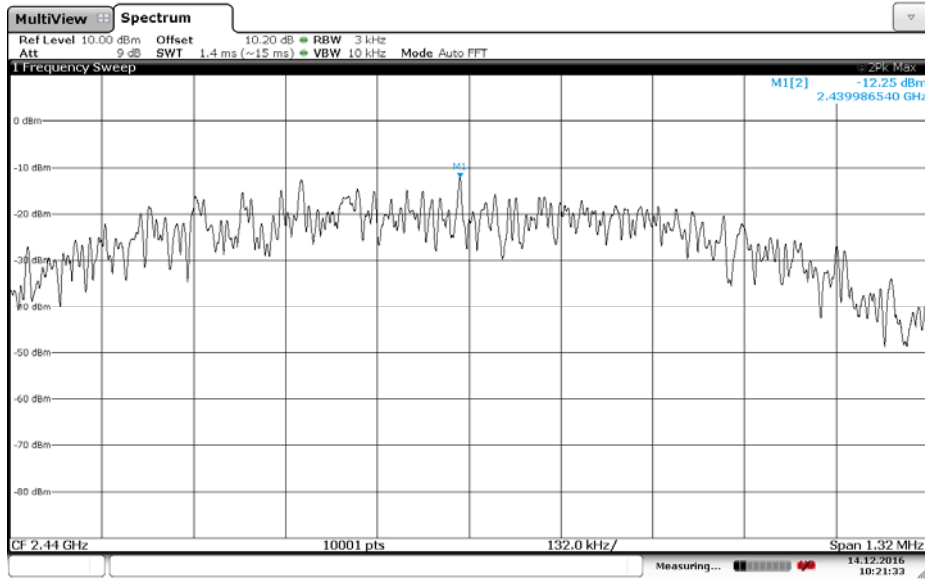

10:21:33 14.12.2016

Figure 7.6.2-2: PSD Plot – MCH

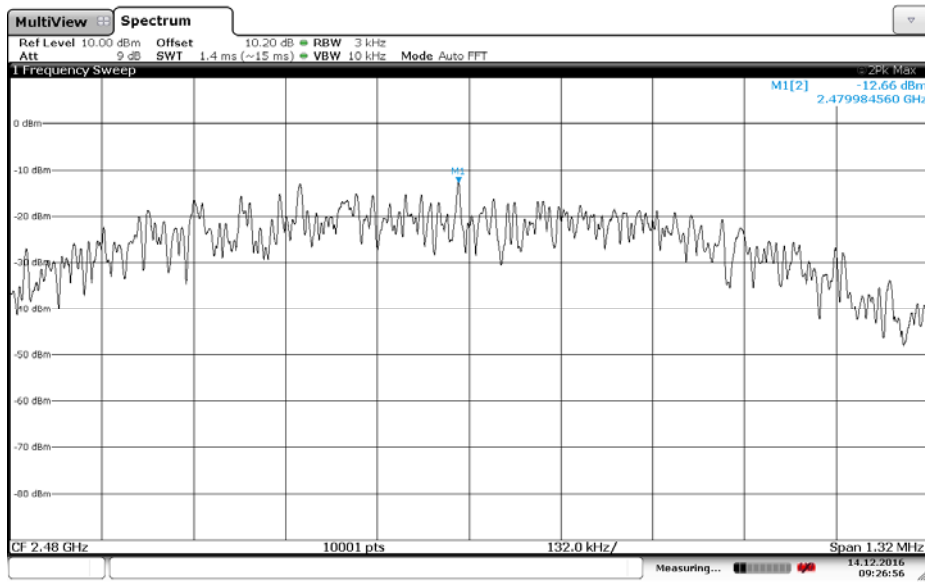

09:26:57 14.12.2016

Figure 7.6.2-3: PSD Plot – HCH

## **8 CONCLUSION**

In the opinion of ACS, Inc. the SPT001M, manufactured by Smart Pet Technologies, LLC meets the requirements of FCC Part 15 subpart C.

**END REPORT**