



FCC Part 15C Test Report

FCC ID: 2AJP6HB-MC-1

Product Name:	Wireless Door Sensor
Trademark:	N/A
Model Name :	HB-MC-1 HB-MC-2
Prepared For :	Ningbo Hengbo Telecommunication Co.,Ltd
Address :	No.1 JinQiao 8th Road,Ninghai County,Ningbo City,Zhejiang Province, China
Prepared By :	Shenzhen BCTC Technology Co., Ltd.
Address :	No.101,Yousong Road,Longhua New District, Shenzhen,China
Test Date:	Aug. 28, - Sep. 05, 2016
Date of Report :	Sep. 05, 2016
Report No.:	BCTC-LH160810531E



VERIFICATION OF COMPLIANCE

Applicant's name: Ningbo Hengbo Telecommunication Co.,Ltd
Address: No.1 JinQiao 8th Road,Ninghai County,Ningbo City,Zhejiang Province, China
Manufacture's Name: Ningbo Hengbo Telecommunication Co.,Ltd
Address: No.1 JinQiao 8th Road,Ninghai County,Ningbo City,Zhejiang Province, China

Product description

Product name: Wireless Door Sensor
Trademark: N/A
Model Name: HB-MC-1
 HB-MC-2
Standards FCC Part15.231
 ANSI C63.10-2013

This device described above has been tested by BCTC, and the test results show that the equipment under test (EUT) is in compliance with the FCC requirements. And it is applicable only to the tested sample identified in the report.

This report shall not be reproduced except in full, without the written approval of BCTC, this document may be altered or revised by BCTC, personal only, and shall be noted in the revision of the document.

Test Result..... : **Pass**

Testing Engineer : Eric Yang
 Eric Yang
 Technical Manager : Jade Yang
 Jade Yang
 Authorized Signatory : Carson Zhang
 Carson Zhang





Table of Contents	Page
1 . SUMMARY OF TEST RESULTS	5
1.1 TEST FACILITY	6
1.2 MEASUREMENT UNCERTAINTY	6
2 . GENERAL INFORMATION	7
2.1 GENERAL DESCRIPTION OF EUT	7
2.2 DESCRIPTION OF TEST MODES	8
2.3 BLOCK DIGRAM SHOWING THE CONFIGURATION OF SYSTEM TESTED	8
2.4 DESCRIPTION OF SUPPORT UNITS(CONDUCTED MODE)	8
2.5 EQUIPMENTS LIST FOR ALL TEST ITEMS	9
3 . EMC EMISSION TEST	10
3.1 CONDUCTED EMISSION MEASUREMENT	10
3.1.1 POWER LINE CONDUCTED EMISSION LIMITS	10
3.1.2 TEST PROCEDURE	10
3.1.3 DEVIATION FROM TEST STANDARD	10
3.1.4 TEST SETUP	11
3.1.5 EUT OPERATING CONDITIONS	11
3.1.6 TEST RESULTS	11
3.2 RADIATED EMISSION MEASUREMENT	12
3.2.1 RADIATED EMISSION LIMITS	12
3.2.2 TEST PROCEDURE	13
3.2.3 DEVIATION FROM TEST STANDARD	14
3.2.4 TEST SETUP	14
3.2.5 EUT OPERATING CONDITIONS	15
3.2.6 TEST RESULTS	16
4 . BANDWIDTH TEST	22
4.1 APPLIED PROCEDURES / LIMIT	22
4.1.1 TEST PROCEDURE	22
4.1.2 DEVIATION FROM STANDARD	22
4.1.3 TEST SETUP	22
4.1.4 EUT OPERATION CONDITIONS	22
4.1.5 TEST RESULTS	23
5 . CALCULATION OF AVERAGE FACTOR	24
6 . DEACTIVATING TIME	25
6.1 DEVIATION FROM STANDARD	25
6.2 TEST SETUP	25



Table of Contents	Page
6.3 EUT OPERATION CONDITIONS	25
6.4 TEST RESULTS	26
7 . ANTENNA REQUIREMENT	27
7.1 STANDARD REQUIREMENT	27
7.2 EUT ANTENNA	27
8 . EUT TEST PHOTO	28
9 . EUT TEST PHOTO	29
APPENDIX-PHOTOGRAPHS OF EUT CONSTRUCTIONAL DETAILS	



1. SUMMARY OF TEST RESULTS

Test procedures according to the technical standards:

FCC Part15 (15.231) , Subpart C			
Standard Section	Test Item	Judgment	Remark
15.207	Conducted Emission	N/A	
15.209,15.231b	Radiated Emission Test	PASS	
15.231c	20dB Occupy Bandwidth	PASS	
15.231a	Deactivating Time	PASS	
15.203	Antenna Requirement	PASS	

NOTE:

(1) "N/A" denotes test is not applicable in this Test Report



1.1 TEST FACILITY

Shenzhen BCTC Technology Co., Ltd.
Add.:No.101,Yousong Road,Longhua New District, Shenzhen,China
FCC Registration No.:187086

1.2 MEASUREMENT UNCERTAINTY

The reported uncertainty of measurement $y \pm U$, where expanded uncertainty U is based on a standard uncertainty multiplied by a coverage factor of $k=2$, providing a level of confidence of approximately **95** %.

No.	Item	Uncertainty
1	Conducted Emission Test	$\pm 1.38\text{dB}$
2	RF power,conducted	$\pm 0.16\text{dB}$
3	Spurious emissions,conducted	$\pm 0.21\text{dB}$
4	All emissions,radiated(<1G)	$\pm 4.68\text{dB}$
5	All emissions,radiated(>1G)	$\pm 4.89\text{dB}$
6	Temperature	$\pm 0.5^{\circ}\text{C}$
7	Humidity	$\pm 2\%$



2. GENERAL INFORMATION

2.1 GENERAL DESCRIPTION OF EUT

Equipment	Wireless Door Sensor
Trade Name	N/A
Model Name	HB-MC-1 HB-MC-2
Model Difference	The product's different for model name and outlook color.
Product Description	The EUT is a Wireless Door Sensor
	Operation Frequency: 434.6MHz
	Modulation Type: FSK+FHSS
	Antenna Designation: internal Antenna
	Antenna Gain 3.0dBi
	Based on the application, features, or specification exhibited in User's Manual, the EUT is considered as an ITE/Computing Device. More details of EUT technical specification, please refer to the User's Manual.
Adapter	N/A
Power	DC 3.6V
Connecting I/O Port(s)	Please refer to the User's Manual
Hardware Version	---
Software Version	----

Note:

1. For a more detailed features description, please refer to the manufacturer's specifications or the User's Manual.



2.2 DESCRIPTION OF TEST MODES

For All Emission	
Final Test Mode	Description
Mode 1	TX Mode

Note:

- (1) New battery is used during the test
- (2) The antenna is telescopic antenna, The worst mode is on max length(7cm).
- (3) For this device equipped with 4 buttons, all 4 buttons was pre-tested and the worst button was Increase the speed button and the data was recrding the report.

2.3 BLOCK DIGRAM SHOWING THE CONFIGURATION OF SYSTEM TESTED

Radiated Spurious Emission Test

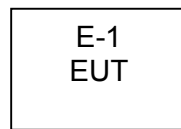

2.4 DESCRIPTION OF SUPPORT UNITS(CONDUCTED MODE)

The EUT has been tested as an independent unit together with other necessary accessories or support units. The following support units or accessories were used to form a representative test configuration during the tests.

Item	Equipment	Mfr/Brand	Model/Type No.	Series No.	Note
E-1	Wireless Door Sensor	N/A	HB-MC-1		EUT

Note:

- (1) The support equipment was authorized by Declaration of Confirmation.
- (2) For detachable type I/O cable should be specified the length in cm in 『Length』 column.
- (3) “YES” is means “shielded” “with core”; “NO” is means “unshielded” “without core”.



2.5 EQUIPMENTS LIST FOR ALL TEST ITEMS

Radiation, 20db bandwidth, Deactivating Time test equipment

Item	Kind of Equipment	Manufacturer	Type No.	Serial No.	Last calibration	Calibrated until
1	Spectrum Analyzer	Agilent	E4407B	MY45108040	Aug. 27, 2016	Aug. 26, 2017
2	Test Receiver	R&S	ESCI	1166.595 0K03-101 165-ha	Aug. 27, 2016	Aug. 26, 2017
3	Bilog Antenna	R&S	VULB 9168	VULB91 68-438	Aug. 27, 2016	Aug. 26, 2017
4	50Ω Coaxial Switch	Anritsu	MP59B	6200264416	Aug. 27, 2016	Aug. 26, 2017
5	Spectrum Analyzer	ADVANTEST	R3132	150900201	Aug. 27, 2016	Aug. 26, 2017
6	Horn Antenna	R&S	HF906	10027	Aug. 30, 2016	Aug. 29, 2017
8	Amplifier	R&S	BBV9743	9743-01 9	Aug. 27, 2016	Aug. 26, 2017
9	Loop Antenna	ARA	PLA-1030/B	1029	Aug. 27, 2016	Aug. 26, 2017
10	RF cables (9kHz~1GHz)	R&S	R203	R20X	Aug. 27, 2016	Aug. 26, 2017
11	Antenna connector (20db bandwidth, Deacti vating Time)	Florida RFLa bs	Lab-Fle	RF 01#	Aug. 27, 2016	Aug. 26, 2017

Note: The temporary antenna connector is soldered on the PCB board in order to perform conducted tests and this temporary antenna connector is listed in the equipment list.



3. EMC EMISSION TEST

3.1 CONDUCTED EMISSION MEASUREMENT

3.1.1 POWER LINE CONDUCTED EMISSION Limits (Frequency Range 150KHz-30MHz)

FREQUENCY (MHz)	Class B (dBuV)		Standard
	Quasi-peak	Average	
0.15 -0.5	66 - 56 *	56 - 46 *	FCC
0.50 -5.0	56.00	46.00	FCC
5.0 -30.0	60.00	50.00	FCC

Note:

- (1) The tighter limit applies at the band edges.
- (2) The limit of " * " marked band means the limitation decreases linearly with the logarithm of the frequency in the range.

The following table is the setting of the receiver

Receiver Parameters	Setting
Attenuation	10 dB
Start Frequency	0.15 MHz
Stop Frequency	30 MHz
IF Bandwidth	9 kHz

3.1.2 TEST PROCEDURE

- a. The EUT was placed 0.8 meters from the horizontal ground plane with EUT being connected to the power mains through a line impedance stabilization network (LISN). All other support equipments powered from additional LISN(s). The LISN provide 50 Ohm/ 50uH of coupling impedance for the measuring instrument.
- b. Interconnecting cables that hang closer than 40 cm to the ground plane shall be folded back and forth in the center forming a bundle 30 to 40 cm long.
- c. I/O cables that are not connected to a peripheral shall be bundled in the center. The end of the cable may be terminated, if required, using the correct terminating impedance. The overall length shall not exceed 1 m.
- d. LISN at least 80 cm from nearest part of EUT chassis.
- e. For the actual test configuration, please refer to the related Item –EUT Test Photos.

3.1.3 DEVIATION FROM TEST STANDARD

No deviation

3.1.4 TEST SETUP

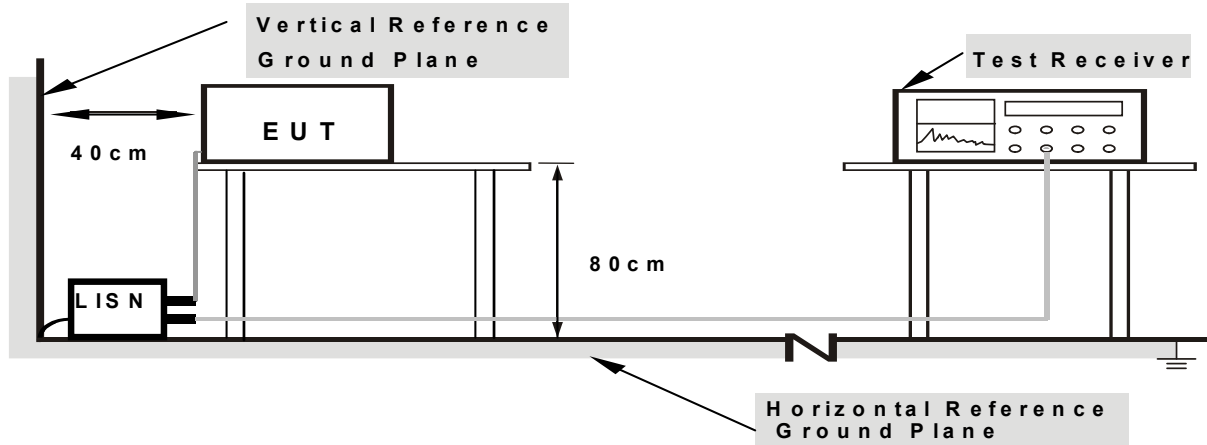

- Note: 1.Support units were connected to second LISN .
2.Both of LISNs (AMN) are 80 cm from EUT and at least 80 from other units and other metal planes

3.1.5 EUT OPERATING CONDITIONS

The EUT was configured for testing in a typical fashion (as a customer would normally use it). The EUT has been programmed to continuously transmit during test. This operating condition was tested and used to collect the included data.

3.1.6 TEST RESULTS

The product's power provide DC 3.6V, no requirment for conduct test.



3.2 RADIATED EMISSION MEASUREMENT

3.2.1 RADIATED EMISSION LIMITS (Frequency Range 9kHz-1000MHz)

20dBc in any 100 kHz bandwidth outside the operating frequency band. In case the emission fall within the restricted band specified on 15.205(a), then the 15.231(b) limit in the table below has to be followed.

Frequencies(MHz)	Field Strength(microrvolts/meter)	Measurement Distance(meters)
0.009~0.490	2400/F(KHz)	300
0.490~1.705	24000/F(KHz)	30
1.705~30.0	30	30
30~88	100	3
88~216	150	3
216~960	200	3
Above 960	500	3

Notes:

- (1) The limit for radiated test was performed according to FCC PART 15C.
- (2) The tighter limit applies at the band edges.
- (3) Emission level (dBuV/m)=20log Emission level (uV/m).

FUNDAMENTAL AND HARMONICS EMISSION LIMITS

Fundamental Frequency (MHz)	Field Strength of Fundamental (microvolts/meter)	Field Strength of Spurious Emissions (microvolts/meter)
40.66 - 40.70	2,250	225
70 - 130	1,250	125
130 - 174	1,250 to 3,750 **	125 to 375 **
174 - 260	3,750	375
260 - 470	3,750 to 12,500 **	375 to 1,250 **
Above 470	12,500	1,250

** linear interpolations

[Where F is the frequency in MHz, the formulas for calculating the maximum permitted fundamental field strengths are as follows: for the band 130-174 MHz, $\mu\text{V/m}$ at 3 meters = $56.81818(F) - 6136.3636$; for the band 260-470 MHz, $\mu\text{V/m}$ at 3 meters = $41.6667(F) - 7083.3333$. The maximum permitted unwanted emission level is 20 dB below the maximum permitted fundamental level.]



FREQUENCY RANGE OF RADIATED MEASUREMENT (For unintentional radiators)

Highest frequency generated or Upper frequency of measurement used in the device or on which the device operates or tunes (MHz)	Range (MHz)
Below 1.705	30
1.705 – 108	1000
108 – 500	2000
500 – 1000	5000
Above 1000	5 th harmonic of the highest frequency or 40 C whichever is lower

Spectrum Parameter	Setting
Attenuation	Auto
Start Frequency	1000 MHz
Stop Frequency	10th carrier harmonic
RBW / VBW setting	1 MHz / 1 MHz for Peak

Receiver Parameter	Setting
Attenuation	Auto
Start ~ Stop Frequency	9kHz~150kHz / RB 200Hz for QP
Start ~ Stop Frequency	150kHz~30MHz / RB 9kHz for QP
Start ~ Stop Frequency	30MHz~1000MHz / RB 120kHz for QP

3.2.2 TEST PROCEDURE

Below 1GHz test procedure as below:

- a. The EUT was placed on the top of a rotating table 0.8 meters above the ground at a 3 meter semi-anechoic chamber. The table was rotated 360 degrees to determine the position of the highest radiation.
- b. The EUT was set 3 meters away from the interference-receiving antenna, which was mounted on the top of a variable-height antenna tower.
- c. The antenna height is varied from one meter to four meters above the ground to determine the maximum value of the field strength. Both horizontal and vertical polarizations of the antenna are set to make the measurement.
- d. For each suspected emission, the EUT was arranged to its worst case and then the antenna was tuned to heights from 1 meter to 4 meters (for the test frequency of below 30MHz, the antenna was tuned to heights 1 meter) and the rotatable table was turned from 0 degrees to 360 degrees to find the maximum reading.
- e. The test-receiver system was set to Peak Detect Function and Specified Bandwidth with Maximum Hold Mode.
- f. If the emission level of the EUT in peak mode was 10dB lower than the limit specified, then testing could be stopped and the peak values of the EUT would be reported. Otherwise the emissions that did not have 10dB margin would be re-tested one by one using peak, quasi-peak or average method as specified and then reported in a data sheet.

Above 1GHz test procedure as below:

g. Different between above is the test site, change from Semi-Anechoic Chamber to fully Anechoic Chamber and change form table 0.8 metre to 1.5 metre(Above 18GHz the distance is 1 meter and table is 1.5 metre).

h. Test the EUT in the lowest channel ,the middle channel ,the Highest channel

Note:

Both horizontal and vertical antenna polarities were tested and performed pretest to three orthogonal axis. The worst case emissions were reported

3.2.3 DEVIATION FROM TEST STANDARD

No deviation

3.2.4 TEST SETUP

(A) Radiated Emission Test-Up Frequency Below 30MHz

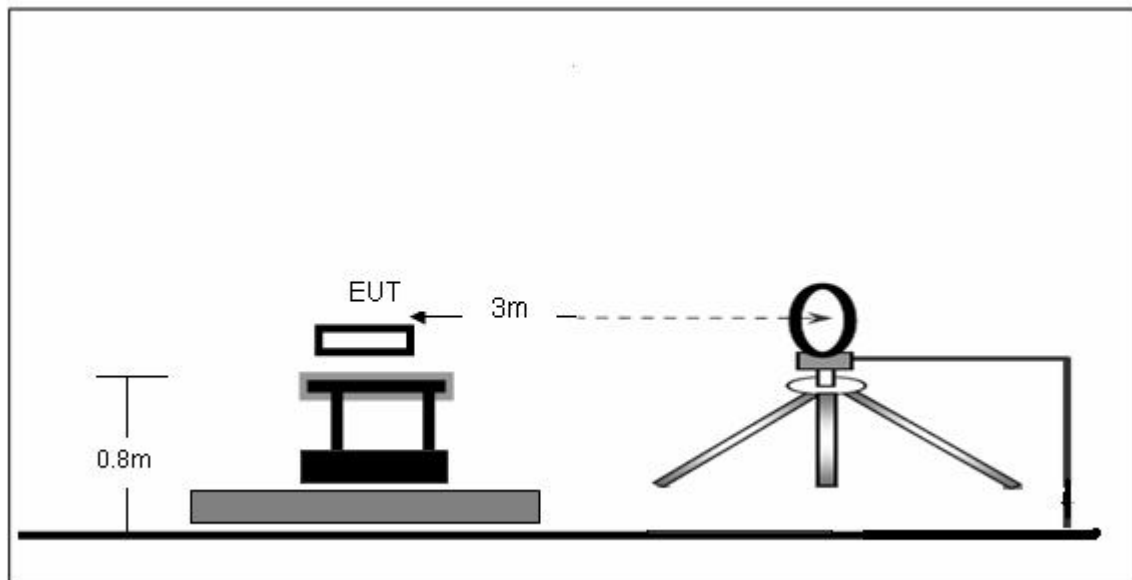

(B) Radiated Emission Test-Up Frequency 30MHz~1GHz

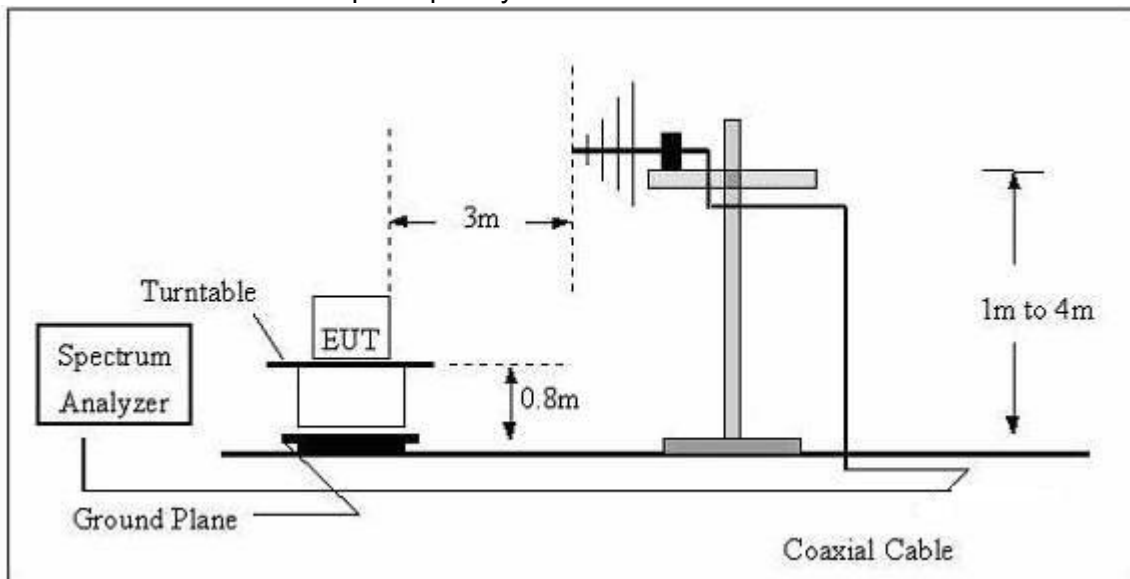

(C) Radiated Emission Test-Up Frequency Above 1GHz

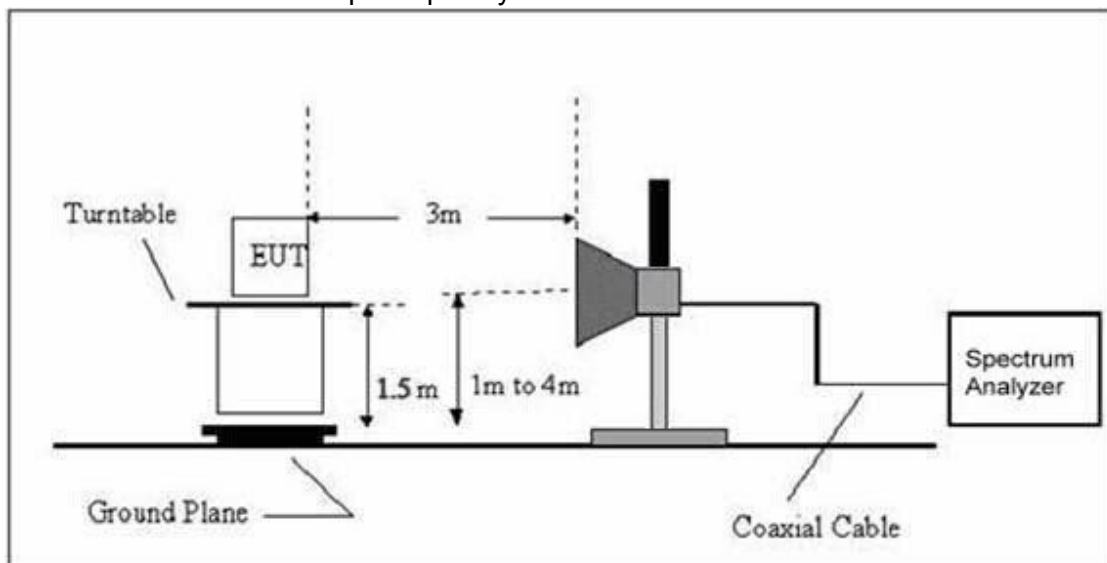

3.2.5 EUT OPERATING CONDITIONS

The EUT tested system was configured as the statements of 2.4 Unless otherwise a special operating condition is specified in the follows during the testing.



3.2.6 TEST RESULTS

Radiated Spurious Emission (Below 30MHz)

EUT :	Wireless Door Sensor	Model Name :	HB-MC-1
Temperature :	20 °C	Relative Humidity :	48%
Pressure :	1010 hPa	Polarization :	---
Test Voltage :	DC 3.6V		
Test Mode :	TX Mode		

Freq.	Reading	Limit	Margin	State
(MHz)	(dBuV/m)	(dBuV/m)	(dB)	P/F
--	--	--	--	PASS
--	--	--	--	PASS

NOTE:

The amplitude of spurious emissions which are attenuated by more than 20dB below the permissible value has no need to be reported.

Distance extrapolation factor = $40 \log(\text{specific distance}/\text{test distance})(\text{dB})$;

Limit line = specific limits(dBuv) + distance extrapolation factor.



Radiated Spurious Emission (Between 30MHz – 1GHz)

Temperature :	26 °C	Relative Humidity :	54%
Pressure :	1010 hPa	Polarization :	Horizontal
Test Voltage :	DC 3.6V		
Test Mode :	TX Mode		

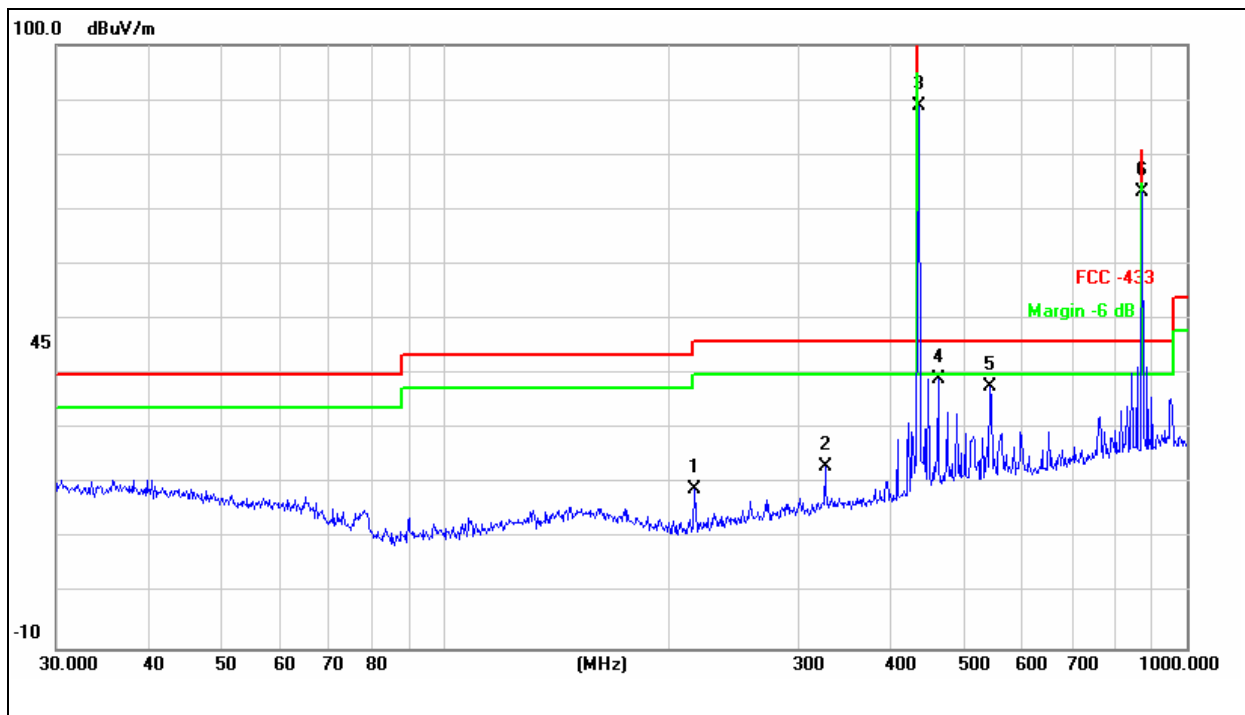

No.	Frequency (MHz)	Reading (dBuV/m)	Ant Factor(dB)	Cable Loss(dB)	Amp Factor(dB)	Result (dBuV/m)	Limit (dBuV/m)	Margin (dB)	Remark
1	216.7828	30.07	17.26	1.24	29.61	18.96	46.00	-27.04	QP
2	325.5958	36.58	16.38	1.28	31.12	23.12	46.00	-22.88	QP
3	434.6000	87.11	17.74	1.31	30.20	75.96	100.85	-24.89	peak
4	462.3455	48.18	17.91	1.33	28.27	39.15	46.00	-6.85	QP
5	543.2742	45.99	18.76	1.42	28.59	37.58	46.00	-8.42	QP
6	869.2000	64.96	19.52	1.67	29.24	56.91	80.85	-23.94	peak

Remark:
 Result = Reading + Ant Factor+ Cable Loss- Amp Factor.
 Margin = Result –Limit



Temperature :	26 °C	Relative Humidity :	54%
Pressure :	1010 hPa	Polarization :	Vertical
Test Voltage :	DC 3.6V		
Test Mode :	TX Mode		

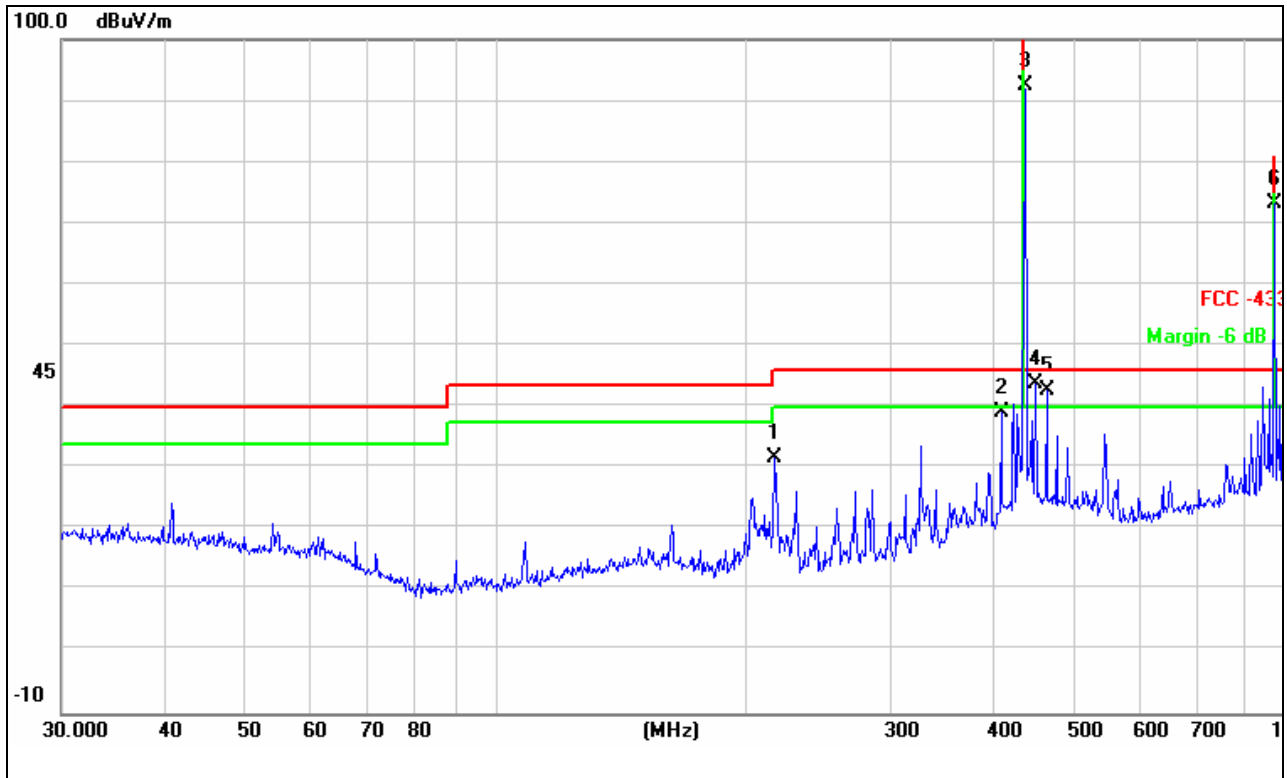

No.	Frequency (MHz)	Reading (dBuV/m)	Ant Factor(dB)	Cable Loss(dB)	Amp Factor(dB)	Result (dBuV/m)	Limit (dBuV/m)	Margin (dB)	Remark
1	216.7828	44.90	15.31	1.24	29.87	31.58	46.00	-14.42	QP
2	407.5145	51.82	16.42	1.28	30.53	38.99	46.00	-7.01	QP
3	434.6000	88.81	17.29	1.31	30.20	77.21	100.85	-23.64	peak
4	447.9822	54.87	17.63	1.33	29.95	43.88	46.00	-2.12	QP
5	462.3455	51.94	18.11	1.42	28.86	42.61	46.00	-3.39	QP
6	869.2000	64.89	19.52	1.67	29.24	56.84	80.85	-24.01	peak

Remark:
 Result = Reading + Ant Factor+ Cable Loss- Amp Factor.
 Margin = Result -Limit



For average Emission

Frequency MHz	Peak Level dBuV/m	Duty cycle factor	AverageLevel dBuV/m	Polarization	Limit AV	Margin
434.6000	77.21	0	77.21	Vertical	80.85	-3.64
869.2000	56.84	0	56.84	Vertical	60.85	-4.01

Notes: 1. Average emission Level = Peak Level + Duty cycle factor
2. Duty cycle level please see clause 5.

Frequency MHz	Peak Level dBuV/m	Duty cycle factor	AverageLevel dBuV/m	Polarization	Limit AV	Margin
434.6000	75.96	0	75.96	Horizontal	80.85	-4.89
869.2000	56.91	0	56.91	Horizontal	60.85	-3.94

Notes: 1. Average emission Level = Peak Level + Duty cycle factor
2. Duty cycle level please see clause 5.



Radiated Spurious Emission (1GHz to 10th harmonics)

Temperature :	26 °C	Relative Humidity :	54%
Pressure :	1010 hPa	Polarization :	Horizontal
Test Voltage :	DC 3.6V		
Test Mode :	TX Mode		

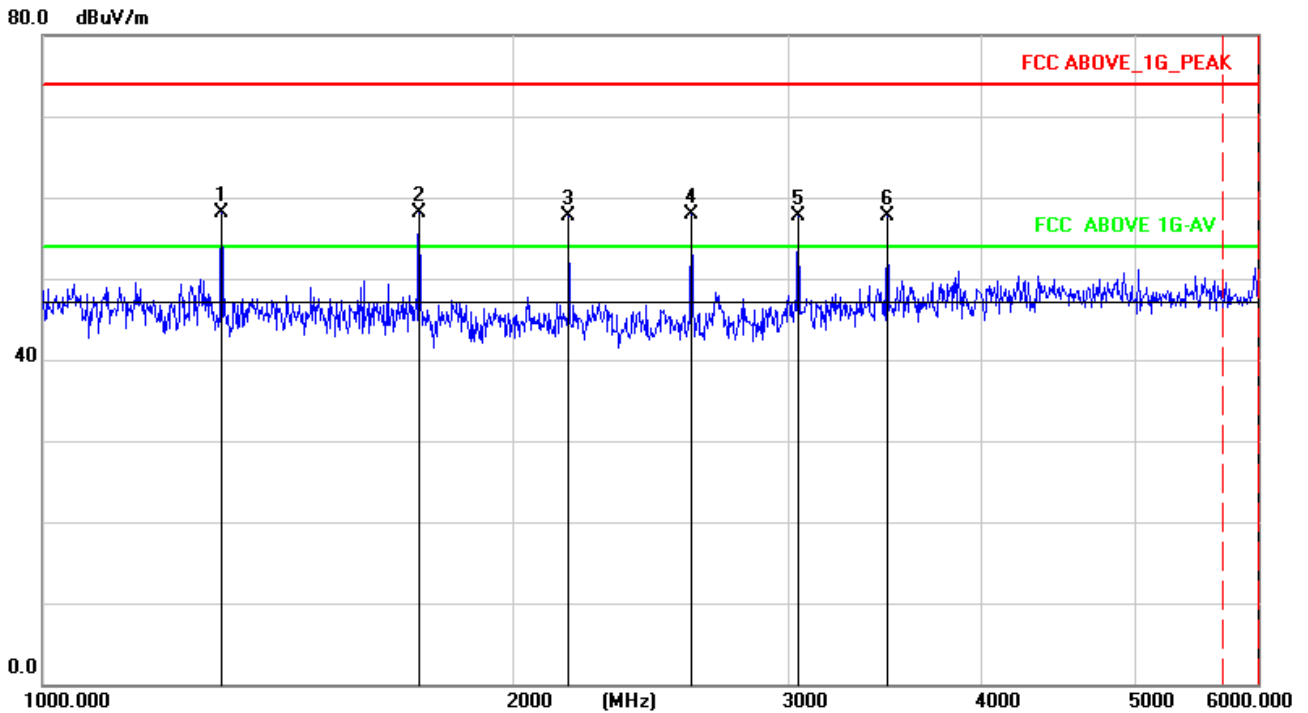

Frequency MHz	Peak Reading Level dBuV/m	Ant Factor dB/m	Cable Loass dB	Amp Factor dB	Peak Level dBuV/m	Duty cycle factor	Average Level dBuV/m	Polariz ation	Limit AV	Limit PK	Margin AV	Margin PK
1303.800	73.43	12.45	2.53	35.24	53.17	0	53.17	H	54.00	74.00	-0.83	-20.83
1738.400	73.81	12.81	2.78	35.24	54.16	0	54.16	H	60.85	80.85	-6.69	-26.69
2173.400	72.62	13.37	2.91	35.38	53.52	0	53.52	H	60.85	80.85	-7.33	-27.33
2607.600	72.63	14.27	3.21	35.38	54.73	0	54.73	H	60.85	80.85	-6.12	-26.12
3042.200	73.14	15.56	3.34	35.64	56.40	0	56.40	H	60.85	80.85	-4.45	-24.45
3476.800	69.22	17.86	3.61	35.64	55.05	0	55.05	H	60.85	80.85	-5.80	-25.80

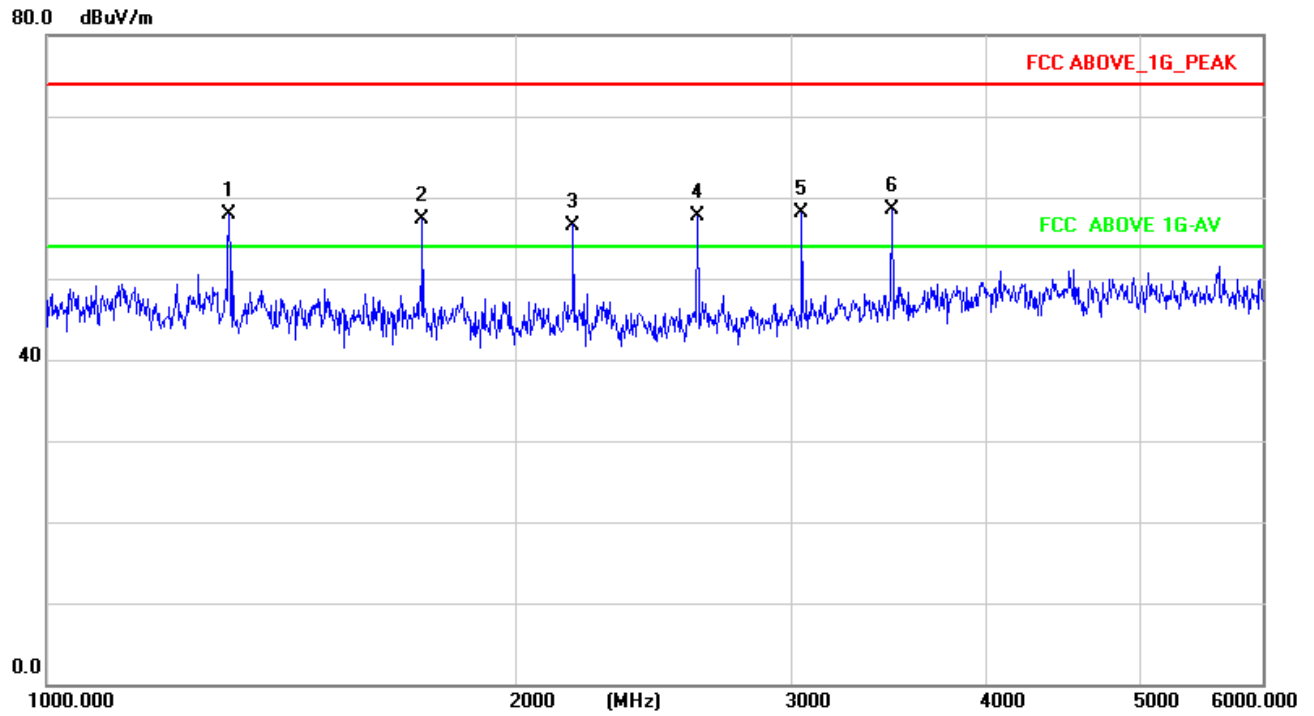

Frequency MHz	Peak Reading Level dBuV/m	Ant Factor dB/m	Cable Loass dB	Amp Factor dB	Peak Level dBuV/m	Duty cycle factor	Average Level dBuV/m	Polariz ation	Limit AV	Limit PK	Margin AV	Margin PK
1303.800	72.91	12.45	2.53	35.24	52.65	0	52.65	H	54.00	74.00	-1.35	-21.35
1738.400	73.29	12.81	2.78	35.24	53.64	0	53.64	H	60.85	80.85	-7.21	-27.21
2173.400	72.10	13.37	2.91	35.38	53.00	0	53.00	H	60.85	80.85	-7.85	-27.85
2607.600	72.11	14.27	3.21	35.38	54.21	0	54.21	H	60.85	80.85	-6.64	-26.64
3042.200	72.62	15.56	3.34	35.64	55.88	0	55.88	H	60.85	80.85	-4.97	-24.97
3476.800	68.73	17.86	3.61	35.64	54.56	0	54.56	H	60.85	80.85	-6.29	-26.29

- Notes: 1. Average emission Level = Peak Level + Duty cycle factor
 2. Peak emission Level = Reading Level + Ant Factor + Cable Loass- Amp Factor
 3. Duty cycle level please see clause 5.
 4. Correct Factor= Cable Loss – Pre-amplifier

4. BANDWIDTH TEST

4.1 APPLIED PROCEDURES / LIMIT

According to FCC 15.231(c) requirement:

The bandwidth of the emission shall be no wider than 0.25% of the center frequency for devices operating between 70 MHz to 900 MHz. Those devices operating above 900 MHz, the emission spurious shall be no wider than 0.5% of the center frequency. Bandwidth is determined at the points 20 dB down from the modulated carrier.

$$B.W (20dBc) \text{ Limit} = 0.25\% * f(\text{MHz}) = 0.25\% * 434.6\text{MHz} = 1.0865\text{MHz}$$

Spectrum Parameter	Setting
Attenuation	Auto
Span Frequency	> Measurement Bandwidth or Channel Separation
RB	100kHz
VB	\geq RBW
Detector	Peak
Trace	Max Hold
Sweep Time	Auto

4.1.1 TEST PROCEDURE

- The EUT was directly connected to the spectrum analyzer and antenna output port as show in the block diagram below,
- Spectrum Setting : RBW= 100kHz, VBW \geq RBW, Sweep time = Auto.

4.1.2 DEVIATION FROM STANDARD

No deviation.

4.1.3 TEST SETUP



4.1.4 EUT OPERATION CONDITIONS

The EUT tested system was configured as the statements of 2.4 Unless otherwise a special operating condition is specified in the follows during the testing.



4.1.5 TEST RESULTS

Temperature :	25 °C	Relative Humidity :	60%
Pressure :	1012 hPa	Test Voltage :	DC 3.6V
Test Mode :	TX Mode		

Frequency	20dB Bandwidth (kHz)	Result
433.92MHz	288	PASS

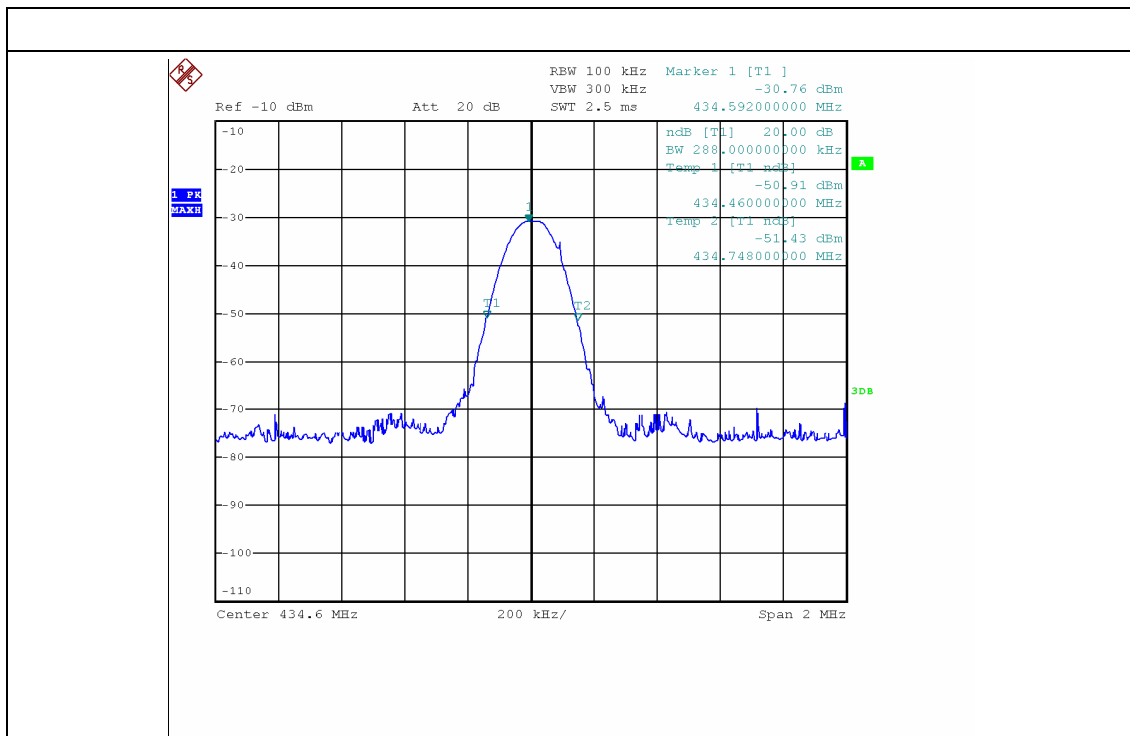



5. CALCULATION OF AVERAGE FACTOR

The output field strengths of specification in accordance with the FCC rules specify measurements with an average detector. During the test, a spectrum analyzer incorporating a peak detector was used. Therefore, a reduction factor can be applied to the resultant peak signal level and compared to the limit for measurement instrumentation incorporating an average detector.

The duty cycle is measured in 100 ms or the repetition cycle period, whichever is a shorter time frame. The duty cycle is measured by placing the spectrum analyzer to set zero span at 100kHz resolution bandwidth.

Averaging factor in dB = $20\log(\text{duty cycle})$

The duration of one cycle = 100ms

The duty cycle is simply the on-time divided the duration of one cycle

Duty Cycle = 100%

Therefore, the averaging factor is found by $20\log 1 = 0\text{dB}$

Test plot as follows:

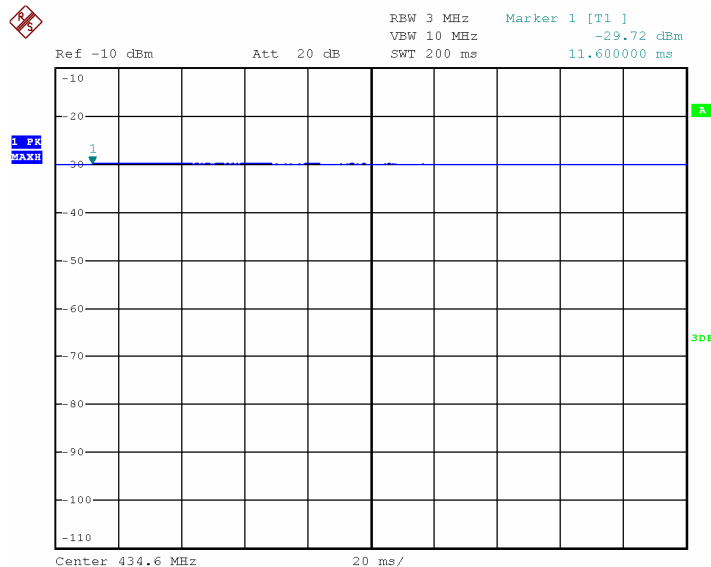



6. DEACTIVATING TIME

APPLICABLE STANDARD

According to FCC 15.231(a) requirement:

A manually operated transmitter shall employ a switch that will automatically deactivate the transmitter within not more than 5 seconds of being released.

TEST PROCEDURE

- a) Check the calibration of the measuring instrument using either an internal calibrator or a known signal from an external generator.
- b) Position the EUT without connection to measurement instrument. Turn on the EUT and connect its antenna terminal to measurement instrument via a low loss cable. Then set it to any one measured frequency within its operating range, and make sure the instrument is operated in its linear range.
- c) Set RBW to 100 kHz and VBW of spectrum analyzer to 300 kHz with a convenient frequency span including 100 kHz bandwidth from band edge.
- d) Measure the highest amplitude appearing on spectral display and set it as a reference level. Plot the graph with marking the highest point and edge frequency.
- e) Repeat above procedures until all measured frequencies were complete.

6.1 DEVIATION FROM STANDARD

No deviation.

6.2 TEST SETUP



6.3 EUT OPERATION CONDITIONS

The EUT tested system was configured as the statements of 2.4 Unless otherwise a special operating condition is specified in the follows during the testing.



6.4 TEST RESULTS

	Deactivating Time (second)	Limit (second)	Result
Normal	1.08	<5s	Pass

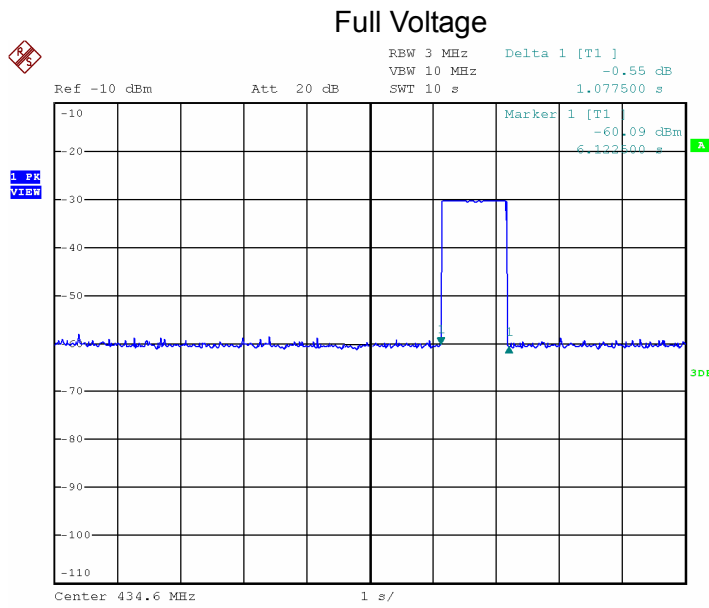



7. ANTENNA REQUIREMENT

7.1 STANDARD REQUIREMENT

15.203 requirement: For intentional device, according to 15.203: an intentional radiator shall be designed to ensure that no antenna other than that furnished by the responsible party shall be used with the device.

7.2 EUT ANTENNA

The EUT antenna is the internal antenna. It comply with the standard requirement.

8. EUT TEST PHOTO

Radiated Measurement Photos

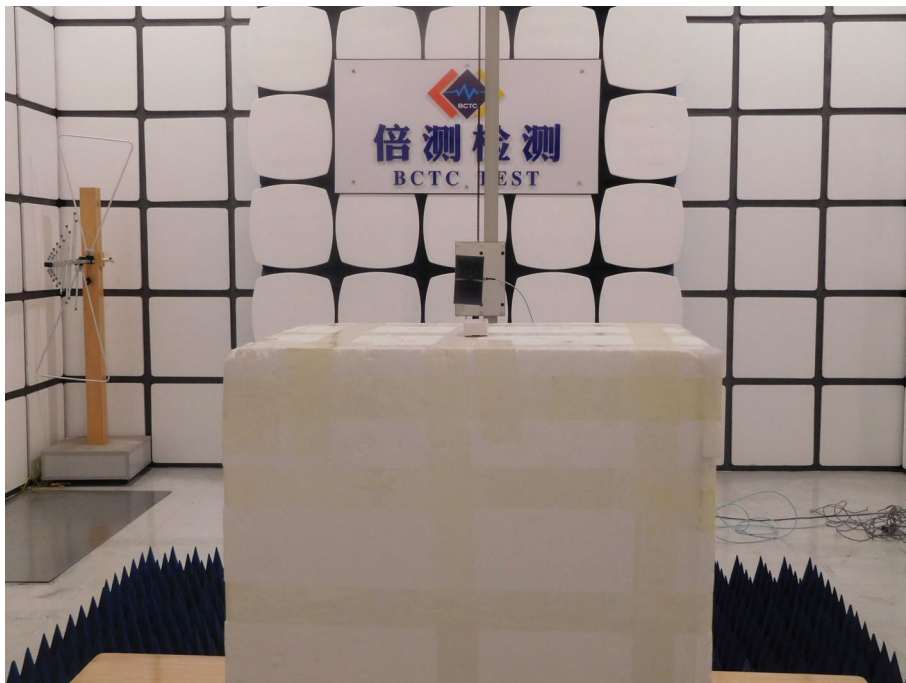
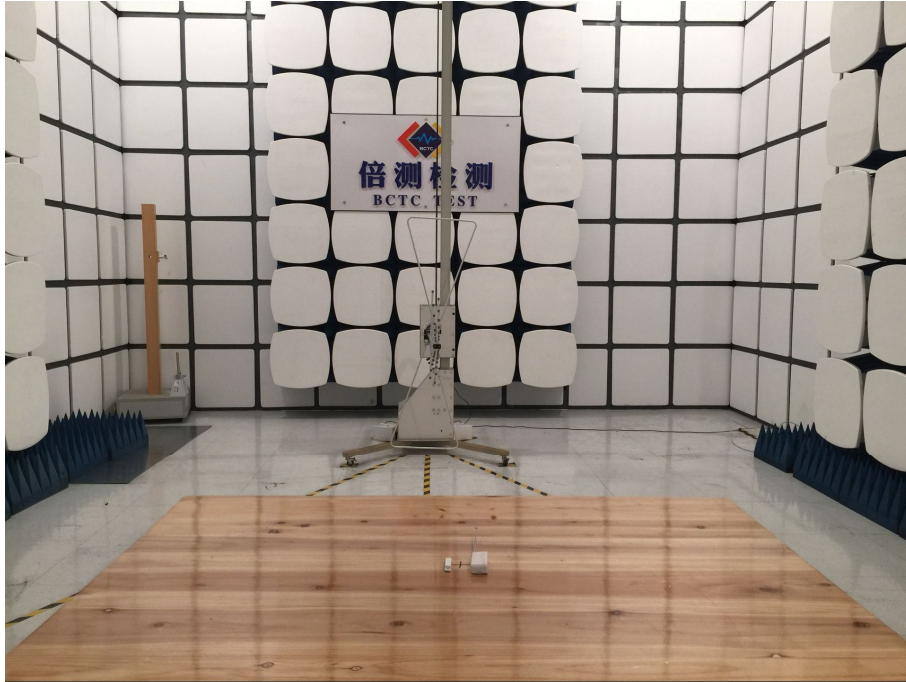

9. EUT TEST PHOTO

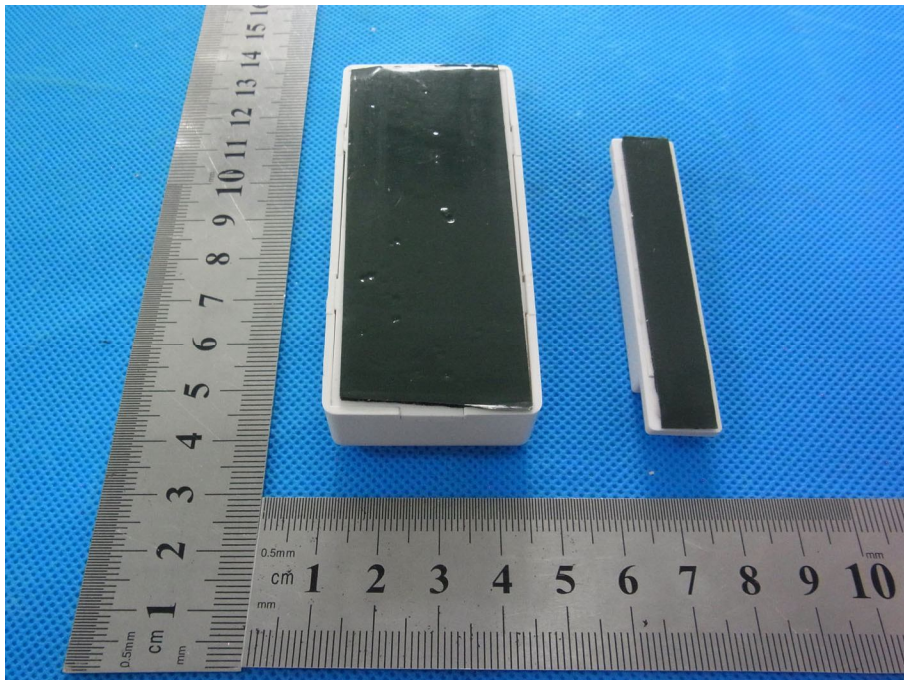
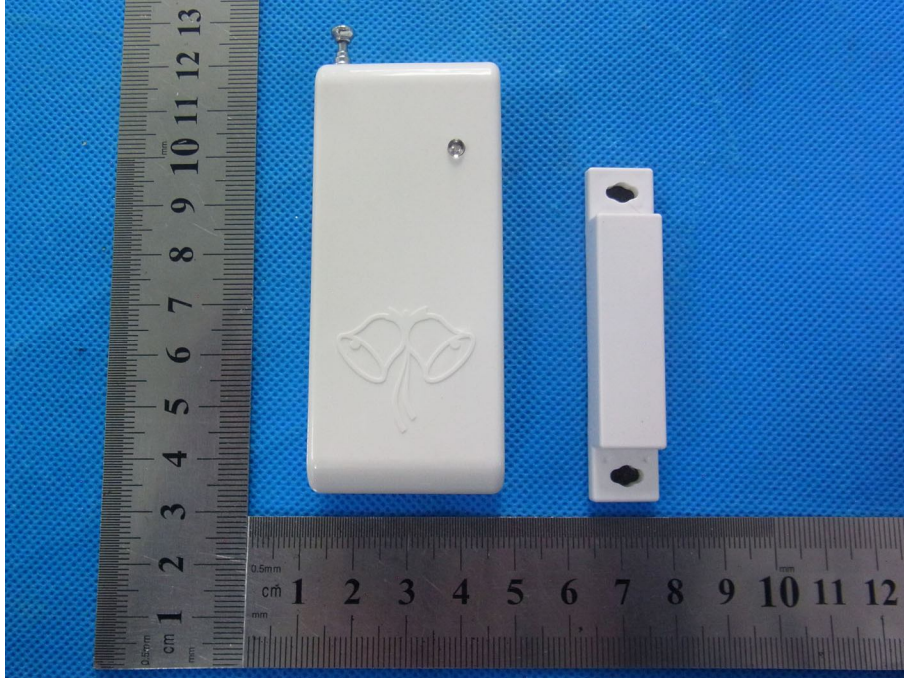

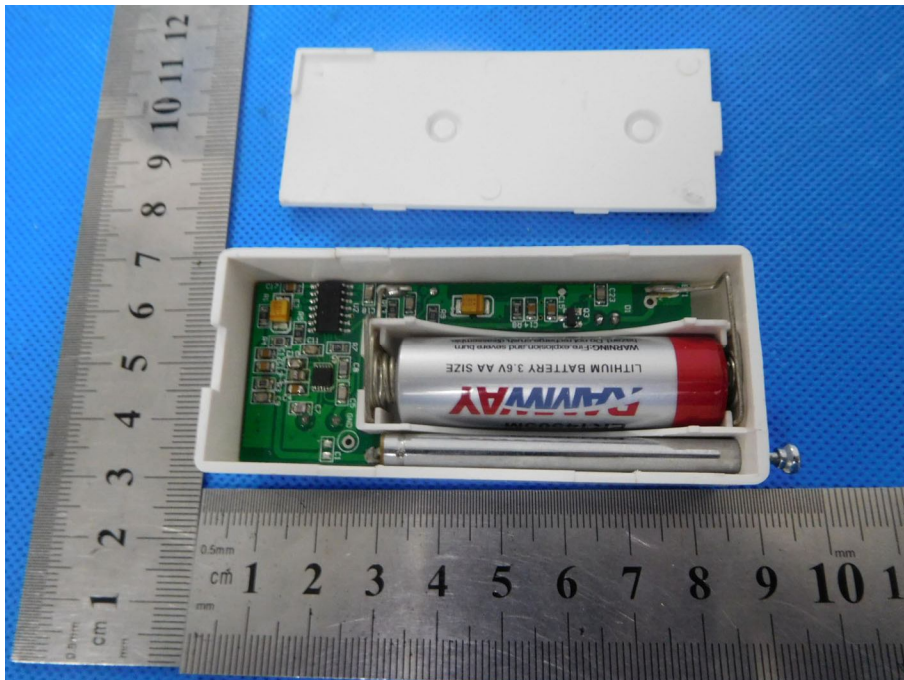

-----END-----