



TEST REPORT

No. 24T04N001218-008-SAR

For

HMD Global Oy

Mobile Phone

Model Name: TA-1686

With

Hardware Version: FF638-MB-V0.2

Software Version: 0.2420.17.00

FCC ID: 2AJOTTA-1686

Issued Date: 2024-07-19

Designation Number: CN1210

Note:

The test results in this test report relate only to the devices specified in this report. This report shall not be reproduced except in full without the written approval of SAICT.

Test Laboratory:

SAICT, Shenzhen Academy of Information and Communications Technology

Building G, Shenzhen International Innovation Center, No.1006 Shennan Road, Futian District, Shenzhen, Guangdong, P. R. China 518000.

Tel:+86(0)755-33322000, Fax:+86(0)755-33322001

Email: yewu@caict.ac.cn. www.saict.ac.cn



REPORT HISTORY

Report Number	Revision	Description	Issue Date
24T04N001218-008-SAR	Rev.0	1st edition	2024-07-19



CONTENTS

1. Summary of Test Report.....	5
1.1. Test Items.....	5
1.2. Test Standards.....	5
1.3. Test Result.....	5
1.4. Testing Location.....	5
1.5. Project Data.....	5
1.6. Signature.....	5
2. Statement of Compliance.....	6
3. Client Information	7
3.1. Applicant Information	7
3.2. Manufacturer Information.....	7
4. Equipment under Test (EUT) and Ancillary Equipment (AE).....	8
4.1. About EUT.....	8
4.2. Internal Identification of EUT used during the test	9
4.3. Internal Identification of AE used during the test.....	9
4.4. General Description	10
5. Test Methodology.....	11
5.1. Applicable Limit Regulations	11
5.2. Applicable Measurement Standards.....	11
6. Specific Absorption Rate (SAR)	12
6.1. Introduction	12
6.2. SAR Definition	12
7. Tissue Simulating Liquids.....	13
7.1. Targets for tissue simulating liquid.....	13
7.2. Dielectric Performance.....	13
8. System verification	15
8.1. System Setup.....	15
8.2. System Verification	16
9. Measurement Procedures	17
9.1. Tests to be performed	17
9.2. General Measurement Procedure	19
9.3. WCDMA Measurement Procedures for SAR	20
9.4. SAR Measurement for LTE	21
9.5. Bluetooth & WLAN Measurement Procedures for SAR.....	22
9.6. Power Drift	22



- 10. Conducted Output Power.....23**
 - 10.1. GSM Measurement result23
 - 10.2. WCDMA Measurement result.....24
 - 10.3. LTE Measurement result.....26
 - 10.4. Bluetooth Measurement result33
- 11. Simultaneous TX SAR Considerations34**
 - 11.1. Introduction.....34
 - 11.2. Transmit Antenna Separation Distances34
 - 11.3. Evaluation of Simultaneous35
- 12. Summary of Test Results36**
 - 12.1. Testing Environment36
 - 12.2. Test Results.....37
- 13. SAR Measurement Variability42**
- 14. Measurement Uncertainty43**
 - 14.1. Measurement Uncertainty for Normal SAR Tests (300MHz~3GHz).....43
 - 14.2. Measurement Uncertainty for Normal SAR Tests (3GHz~6GHz).....44
- 15. Main Test Instruments45**
- ANNEX A: Graph Results46**
- ANNEX B: SystemVerification Results92**
- ANNEX C: SAR Measurement Setup.....103**
- ANNEX D: Position of the wireless device in relation to the phantom109**
- ANNEX E: Equivalent Media Recipes.....112**
- ANNEX F: System Validation113**
- ANNEX G: DAE Calibration Certificate114**
- ANNEX H: Probe Calibration Certificate.....119**
- ANNEX I: Dipole Calibration Certificate.....141**
- ANNEX J: Extended Calibration SAR Dipole177**

1. Summary of Test Report

1.1. Test Items

Description:	Mobile Phone
Model Name:	TA-1686
Applicant's Name:	HMD Global Oy
Manufacturer's Name:	HMD Global Oy

1.2. Test Standards

ANSI C95.1:1992, IEEE 1528:2013

1.3. Test Result

Pass. Please refer to "12. Summary of Test Results"

1.4. Testing Location

Address: Building G, Shenzhen International Innovation Center, No.1006 Shennan Road, Futian District, Shenzhen, Guangdong, P. R. China

1.5. Project Data

Testing Start Date: 2024-06-21

Testing End Date: 2024-07-09

1.6. Signature

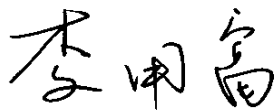

Li Yongfu
(Prepared this test report)

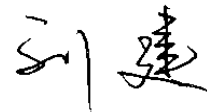

Liu Jian
(Reviewed this test report)

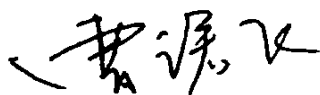

Cao Junfei
(Approved this test report)

2. Statement of Compliance

The maximum results of Specific Absorption Rate (SAR) found during testing for HMD Global Oy Mobile Phone TA-1686 are as follows:

Table 2.1: Highest Reported SAR (1g)

Equipment Class	Frequency Bands	1g SAR (W/kg)	
		Head (Separation 0mm)	Body-worn (Separation 15mm)
PCE	GSM 850	0.77	0.92
	GSM 1900	0.23	0.50
	WCDMA Band 2	0.48	0.75
	WCDMA Band 4	0.46	1.03
	WCDMA Band 5	0.96	1.14
	LTE Band 2	0.60	0.85
	LTE Band 5	1.38	1.01
	LTE Band 7	0.88	0.58
	LTE Band 12/17	0.51	0.41
	LTE Band 13	1.02	0.86
LTE Band 66/4	0.39	0.96	
DSS	Bluetooth	0.09	0.01

The SAR values found for the Mobile Phone are below the maximum recommended levels of 1.6 W/Kg as averaged over any 1g tissue according to the ANSI C95.1:1992.

The measurement together with the test system set-up is described in annex C of this test report. A detailed description of the equipment under test can be found in chapter 4 of this test report.

The highest reported SAR value is obtained at the case of (**Table 2.1**), Head value is **1.38 W/kg (1g)** and Body-worn value is **1.14 W/kg (1g)**.

Table 2.2: Maximum Simultaneous Transmission SAR

/	Position	Sum (W/kg)
Highest reported SAR value for Head	Left Cheek (LTE Band 5 + Bluetooth)	1.47
Highest reported SAR value for Body-worn	Rear Side (WCDMA Band 5 + Bluetooth)	1.14

Note: the test positions of above tables are for the worse case that has been evaluated.

According to the above tables, the highest sum of reported SAR values is **1.47 W/kg (1g)**.

The detail for simultaneous transmission consideration is described in chapter 11.



3. Client Information

3.1. Applicant Information

Company Name:	HMD Global Oy
Address:	Bertel Jungin aukio 9, 02600 Espoo, Finland
Contact:	reza.serafat
Email:	reza.serafat@hmdglobal.com
Telephone:	+491735287964

3.2. Manufacturer Information

Company Name:	HMD Global Oy
Address:	Bertel Jungin aukio 9, 02600 Espoo, Finland
Contact:	reza.serafat
Email:	reza.serafat@hmdglobal.com
Telephone:	+491735287964

4. Equipment under Test (EUT) and Ancillary Equipment (AE)

4.1. About EUT

Description:	Mobile Phone
Model Name:	TA-1686
Condition of EUT as received:	No obvious damage in appearance
Frequency Bands:	GSM 850/900/1800/1900, WCDMA Band 1/2/4/5/8, LTE Band 1/2/3/4/5/7/8/12/13/17/28/40/66, Bluetooth
Tested Tx Frequency:	824 – 849MHz (GSM 850)
	1850 – 1910MHz (GSM 1900)
	1850 – 1910MHz (WCDMA Band 2)
	1710 – 1755MHz (WCDMA Band 4)
	824 – 849MHz (WCDMA Band 5)
	1850 – 1910MHz (LTE Band 2)
	1710 – 1755MHz (LTE Band 4)
	824 – 849MHz (LTE Band 5)
	2500 – 2570MHz (LTE Band 7)
	699 – 716MHz (LTE Band 12)
	777 – 787MHz (LTE Band 13)
	704 – 716MHz (LTE Band 17)
	1710 – 1780MHz (LTE Band 66)
2402 – 2480MHz (Bluetooth)	
GPRS Multislot Class:	12
GPRS Capability Class:	B
Dual Transfer Mode (DTM)	Not support
Test device Production information:	Production unit
Device type:	Portable device
Antenna type:	Integrated antenna
Hotspot mode:	Not Support
Product Dimensions:	Long 121.53mm; Wide 52.0mm; Overall Diagonal 132.54mm
Note: LTE Band 40 be disabled by software.	

4.2. Internal Identification of EUT used during the test

EUT ID*	IMEI	HW Version	SW Version	Receipt Date
UT01aa	352178850000637	FF638-MB-V0.2	0.2420.17.00	2024-06-09
UT11aa	352178850000959	FF638-MB-V0.2	0.2420.17.00	2024-06-09
UT19aa	352178850003151	FF638-MB-V0.2	0.2420.17.00	2024-06-09
UT23aa	352178850001890	FF638-MB-V0.2	0.2420.17.00	2024-06-09
UT24aa	867400020316612	FF638-MB-V0.2	0.2420.17.00	2024-06-09

*EUT ID: is used to identify the test sample in the lab internally.

Note: It is performed to test SAR with the UT01aa & UT19aa & UT23aa & UT24aa, and conducted power with the UT11aa.

4.3. Internal Identification of AE used during the test

AE ID*	Description	Model	Manufacturer
AE1	Battery	BA-L4M	SHENZHEN UTILITY ENERGY CO., LTD.
AE2	Battery	BA-L4M	Guangdong Fenghua New Energy Co., Ltd.
AE3	Headset	JWEP1273-W27H	HUIZHOU JUWEI ELECTRONICS CO., LTD

*AE ID: is used to identify the test sample in the lab internally.

Note: The device has two types of batteries. We perform the SAR measurement with AE1 battery and Spot check test with AE2 battery.

5. Test Methodology

5.1. Applicable Limit Regulations

ANSI C95.1:1992 IEEE Standard for Safety Levels with Respect to Human Exposure to Radio Frequency Electromagnetic Fields, 3 kHz to 300 GHz.

It specifies the maximum exposure limit of **1.6 W/kg** as averaged over any 1 gram of tissue for portable devices being used within 20 cm of the user in the uncontrolled environment.

5.2. Applicable Measurement Standards

IEEE 1528:2013 Recommended Practice for Determining the Peak Spatial-Average Specific Absorption Rate (SAR) in the Human Head from Wireless Communications Devices: Experimental Techniques.

KDB 447498 D01 General RF Exposure Guidance v06 RF Exposure Procedures and Equipment Authorization Policies for Mobile and Portable Devices

KDB 648474 D04 Handset SAR v01r03 SAR Evaluation Considerations for Wireless Handsets.

KDB 941225 D01 SAR test for 3G devices v03r01 SAR Measurement Procedures for 3G Devices

KDB 941225 D05 SAR for LTE Devices v02r05 SAR Evaluation Considerations for LTE Devices

KDB 865664 D01 SAR measurement 100 MHz to 6 GHz v01r04 SAR Measurement Requirements for 100 MHz to 6 GHz

KDB 865664 D02 RF Exposure Reporting v01r02 RF Exposure Compliance Reporting and Documentation Considerations

TCB workshop April 2019; RF Exposure Procedures (Tissue Simulating Liquids)

6. Specific Absorption Rate (SAR)

6.1. Introduction

SAR is related to the rate at which energy is absorbed per unit mass in an object exposed to a radio field. The SAR distribution in a biological body is complicated and is usually carried out by experimental techniques or numerical modeling. The standard recommends limits for two tiers of groups, occupational/controlled and general population/uncontrolled, based on a person's awareness and ability to exercise control over his or her exposure. In general, occupational/controlled exposure limits are higher than the limits for general population/uncontrolled.

6.2. SAR Definition

The SAR definition is the time derivative (rate) of the incremental energy (dW) absorbed by (dissipated in) an incremental mass (dm) contained in a volume element (dv) of a given density (ρ). The equation description is as below:

$$SAR = \frac{d}{dt} \left(\frac{dW}{dm} \right) = \frac{d}{dt} \left(\frac{dW}{\rho dv} \right)$$

SAR is expressed in units of Watts per kilogram (W/kg)

SAR measurement can be either related to the temperature elevation in tissue by

$$SAR = c \left(\frac{\delta T}{\delta t} \right)$$

Where: C is the specific heat capacity, δT is the temperature rise and δt is the exposure duration, or related to the electrical field in the tissue by

$$SAR = \frac{\sigma |E|^2}{\rho}$$

Where: σ is the conductivity of the tissue, ρ is the mass density of tissue and E is the RMS electrical field strength.

However for evaluating SAR of low power transmitter, electrical field measurement is typically applied.

7. Tissue Simulating Liquids

7.1. Targets for tissue simulating liquid

Table 7.1: Targets for tissue simulating liquid

Frequency (MHz)	Liquid Type	Conductivity (σ)	$\pm 5\%$ Range	Permittivity (ϵ)	$\pm 5\%$ Range
750	Head	0.89	0.85~0.93	41.9	39.8~44.0
835	Head	0.90	0.86~0.95	41.5	39.4~43.6
1750	Head	1.37	1.30~1.44	40.1	38.1~42.1
1900	Head	1.40	1.33~1.47	40.0	38.0~42.0
2450	Head	1.80	1.71~1.89	39.2	37.2~41.2
2550	Head	1.91	1.81~2.01	39.1	37.1~41.0

7.2. Dielectric Performance

Table 7.2: Dielectric Performance of Tissue Simulating Liquid

Measurement Date (yyyy-mm-dd)	Frequency (MHz)	Type	Conductivity σ (S/m)	Drift (%)	Permittivity ϵ	Drift (%)
2024-06-25	750	Head	0.887	-0.34	42.35	1.07
2024-07-05	835	Head	0.911	1.22	40.63	-2.10
2024-06-21	1750	Head	1.388	1.31	39.44	-1.65
2024-07-07	1900	Head	1.426	1.86	39.20	-2.00
2024-07-09	2450	Head	1.783	-0.94	39.79	1.51
2024-07-03	2550	Head	1.952	2.20	38.16	-2.40

Note: The liquid temperature is 22.0°C.

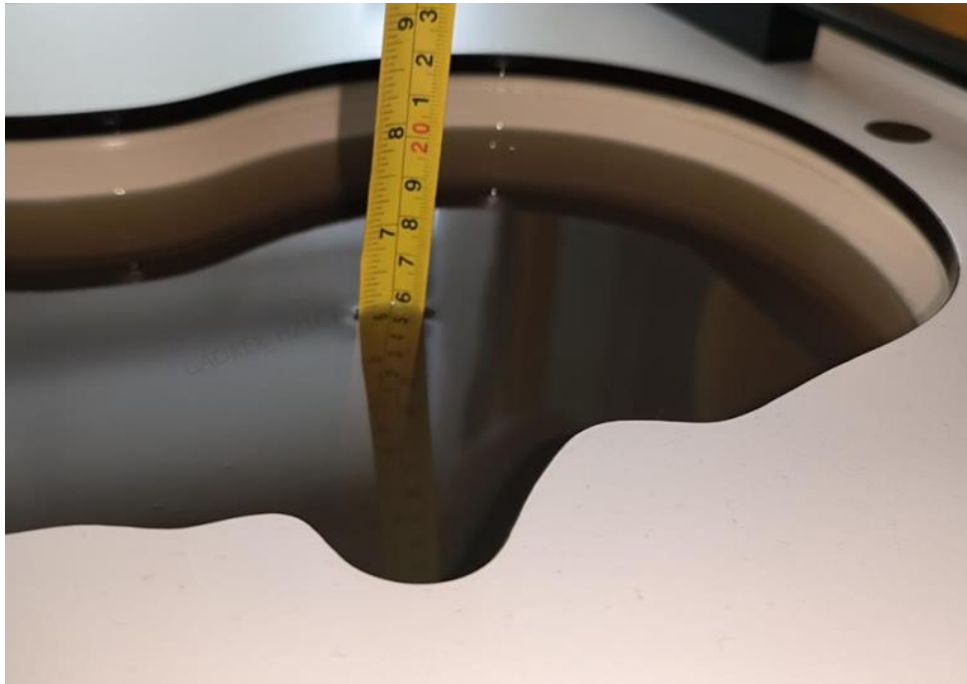

Picture 7.1 Liquid depth in the Head Phantom (0.7GHz - 6.5GHz)

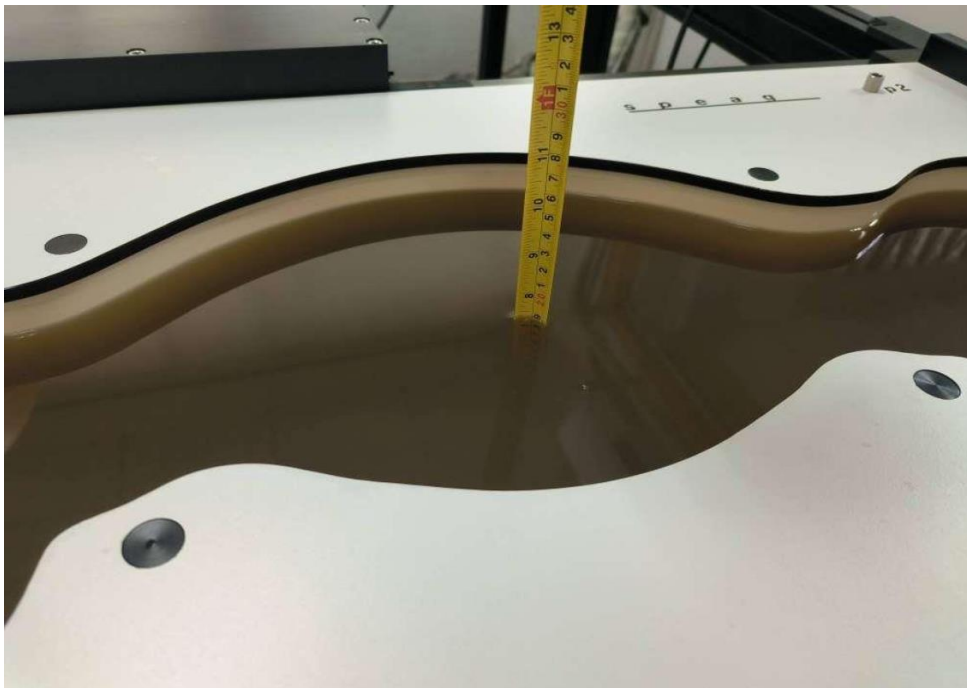

Picture 7.1 Liquid depth in the Flat Phantom (0.7GHz - 6.5GHz)

8. System verification

8.1. System Setup

In the simplified setup for system evaluation, the DUT is replaced by a calibrated dipole and the power source is replaced by a continuous wave that comes from a signal generator. The calibrated dipole must be placed beneath the flat phantom section of the SAM twin phantom with the correct distance holder. The distance holder should touch the phantom surface with a light pressure at the reference marking and be oriented parallel to the long side of the phantom. The equipment setup is shown below:

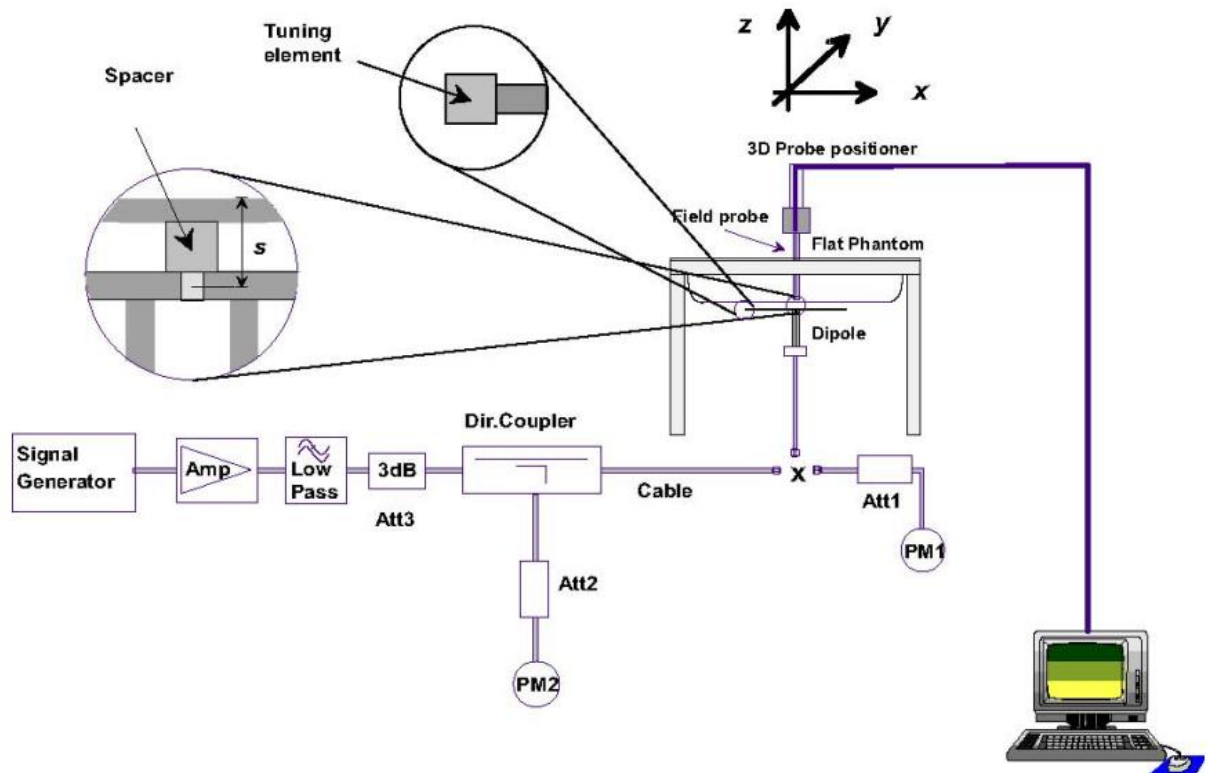

Picture 8.1 System Setup for System Evaluation

For the dipole below 3GHz, the output power on dipole port must be calibrated to 24 dBm (250mW) before dipole is connected.

For the dipole above 3GHz, the output power on dipole port must be calibrated to 20 dBm (100mW) before dipole is connected.

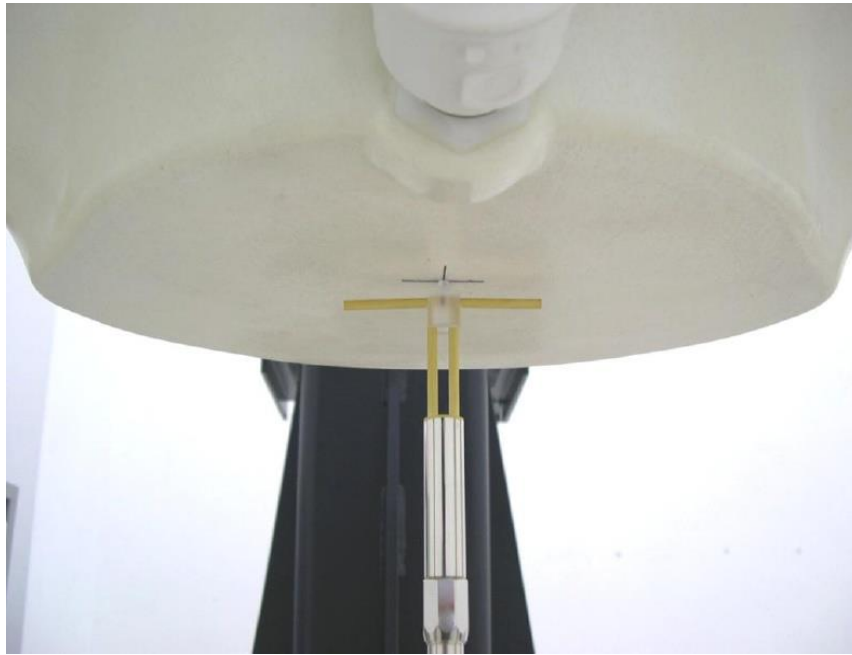

Picture 8.2 Photo of Dipole Setup

8.2. System Verification

SAR system verification is required to confirm measurement accuracy, according to the tissue dielectric media, probe calibration points and other system operating parameters required for measuring the SAR of a test device. The system verification must be performed for each frequency band and within the valid range of each probe calibration point required for testing the device.

Table 8.1: System Verification of Head

Measurement Date	Frequency (MHz)	Target value (W/kg)		Measured value (W/kg)				Deviation (%)	
				/		Normalize to 1W			
		1 g	10 g	1 g	10 g	1 g	10 g	1 g	10 g
2024-06-25	750	8.48	5.62	2.04	1.36	8.16	5.44	-3.77	-3.20
2024-07-05	835	9.64	6.29	2.48	1.60	9.92	6.40	2.90	1.75
2024-06-21	1750	36.30	19.60	9.21	4.95	36.84	19.80	1.49	1.02
2024-07-07	1900	40.20	20.50	10.4	5.26	41.60	21.04	3.48	2.63
2024-07-09	2450	53.20	24.20	13.1	6.03	52.40	24.12	-1.50	-0.33
2024-07-03	2550	55.00	25.00	14.2	6.38	56.80	25.52	3.27	2.08

9. Measurement Procedures

9.1. Tests to be performed

In order to determine the highest value of the peak spatial-average SAR of a handset, all device positions, configurations and operational modes shall be tested for each frequency band according to steps 1 to 3 below. A flowchart of the test process is shown in picture 9.1.

Step 1: The tests described in 9.2 shall be performed at the channel that is closest to the center of the transmit frequency band (f_c) for:

- a) all device positions (cheek and tilt, for both left and right sides of the SAM phantom, as described in annex D),
- b) all configurations for each device position in a), e.g., antenna extended and retracted, and
- c) all operational modes, e.g., analogue and digital, for each device position in a) and configuration in b) in each frequency band.

If more than three frequencies need to be tested according to 11.1 (i.e., $N_C > 3$), then all frequencies, configurations and modes shall be tested for all of the above test conditions.

Step 2: For the condition providing highest peak spatial-average SAR determined in Step 1, perform all tests described in 9.2 at all other test frequencies, i.e., lowest and highest frequencies. In addition, for all other conditions (device position, configuration and operational mode) where the peak spatial-average SAR value determined in Step 1 is within 3 dB of the applicable SAR limit, it is recommended that all other test frequencies shall be tested as well.

Step 3: Examine all data to determine the highest value of the peak spatial-average SAR found in Steps 1 to 2.

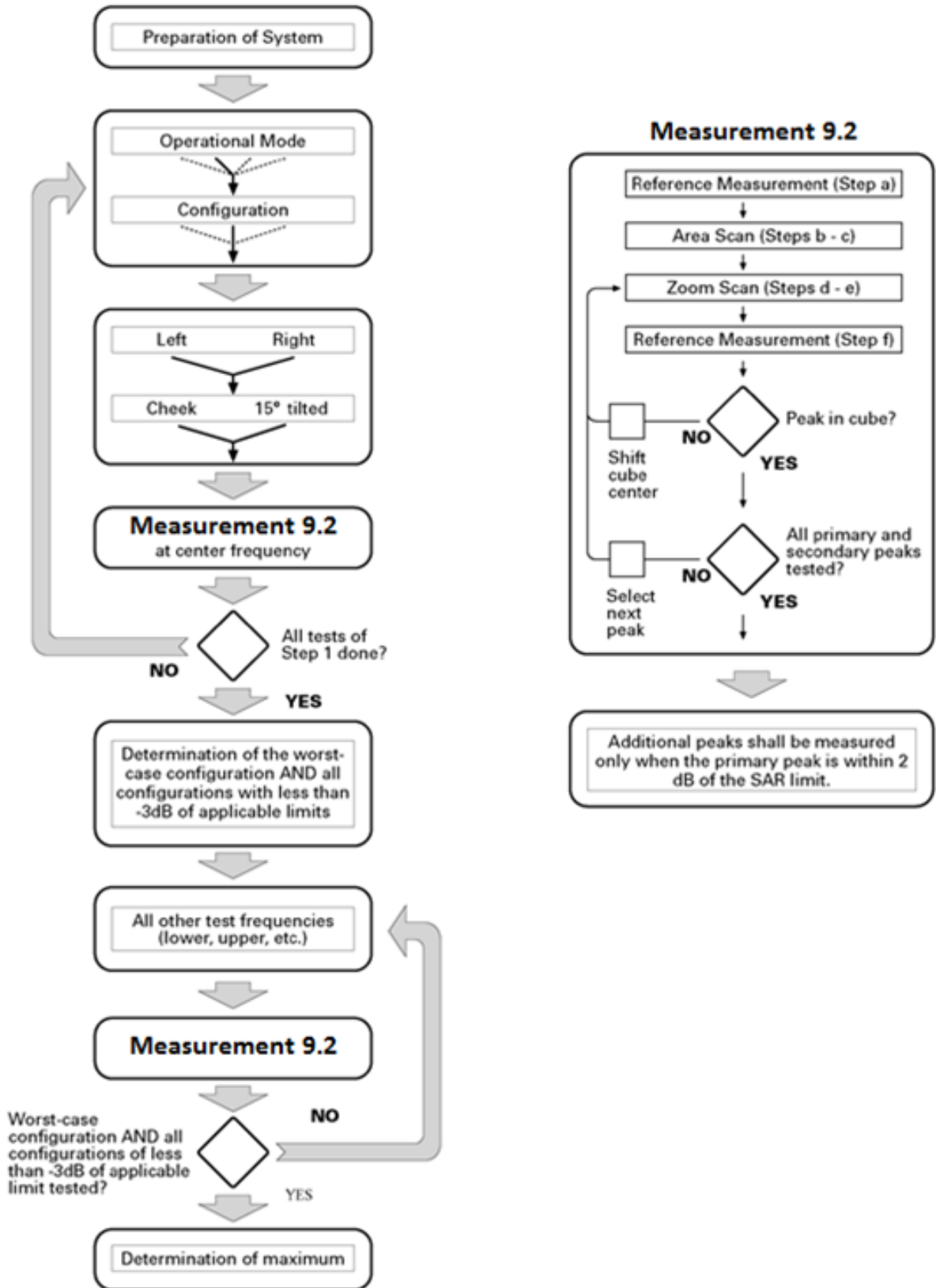

Picture 9.1 Block diagram of the tests to be performed

9.2. General Measurement Procedure

The area and zoom scan resolutions specified in the table below must be applied to the SAR measurements and fully documented in SAR reports to qualify for TCB approval. Probe boundary effect error compensation is required for measurements with the probe tip closer than half a probe tip diameter to the phantom surface. Both the probe tip diameter and sensor offset distance must satisfy measurement protocols; to ensure probe boundary effect errors are minimized and the higher fields closest to the phantom surface can be correctly measured and extrapolated to the phantom surface for computing 1-g SAR. Tolerances of the post-processing algorithms must be verified by the test laboratory for the scan resolutions used in the SAR measurements, according to the reference distribution functions specified in IEEE Std 1528-2013. The results should be documented as part of the system validation records and may be requested to support test results when all the measurement parameters in the following table are not satisfied.

		≤ 3 GHz	> 3 GHz	
Maximum distance from closest measurement point (geometric center of probe sensors) to phantom surface		5 ± 1 mm	$\frac{\delta}{2} \ln(2) \pm 0.5$ mm	
Maximum probe angle from probe axis to phantom surface normal at the measurement location		$30^\circ \pm 1^\circ$	$20^\circ \pm 1^\circ$	
Maximum area scan spatial resolution: Δx_{Area} , Δy_{Area}		≤ 2 GHz: ≤ 15 mm 2 – 3 GHz: ≤ 12 mm	3 – 4 GHz: ≤ 12 mm 4 – 6 GHz: ≤ 10 mm	
		When the x or y dimension of the test device, in the measurement plane orientation, is smaller than the above, the measurement resolution must be \leq the corresponding x or y dimension of the test device with at least one measurement point on the test device.		
Maximum zoom scan spatial resolution: Δx_{Zoom} , Δy_{Zoom}		≤ 2 GHz: ≤ 8 mm 2 – 3 GHz: ≤ 5 mm*	3 – 4 GHz: ≤ 5 mm* 4 – 6 GHz: ≤ 4 mm*	
Maximum zoom scan spatial resolution, normal to phantom surface	uniform grid: $\Delta z_{Zoom}(n)$	≤ 5 mm	3 – 4 GHz: ≤ 4 mm 4 – 5 GHz: ≤ 3 mm 5 – 6 GHz: ≤ 2 mm	
	graded grid	$\Delta z_{Zoom}(1)$: between 1 st two points closest to phantom surface	≤ 4 mm	3 – 4 GHz: ≤ 3 mm 4 – 5 GHz: ≤ 2.5 mm 5 – 6 GHz: ≤ 2 mm
		$\Delta z_{Zoom}(n>1)$: between subsequent points	$\leq 1.5 \cdot \Delta z_{Zoom}(n-1)$	
Minimum zoom scan volume	x, y, z	≥ 30 mm	3 – 4 GHz: ≥ 28 mm 4 – 5 GHz: ≥ 25 mm 5 – 6 GHz: ≥ 22 mm	
<p>Note: δ is the penetration depth of a plane-wave at normal incidence to the tissue medium; see draft standard IEEE P1528-2011 for details.</p> <p>* When zoom scan is required and the <i>reported</i> SAR from the area scan based 1-g SAR estimation procedures of KDB 447498 is ≤ 1.4 W/kg, ≤ 8 mm, ≤ 7 mm and ≤ 5 mm zoom scan resolution may be applied, respectively, for 2 GHz to 3 GHz, 3 GHz to 4 GHz and 4 GHz to 6 GHz.</p>				

9.3. WCDMA Measurement Procedures for SAR

The following procedures are applicable to WCDMA handsets operating under 3GPP Release99, Release 5 and Release 6. The default test configuration is to measure SAR with an established radio link between the DUT and a communication test set using a 12.2kbps RMC (reference measurement channel) configured in Test Loop Mode 1. SAR is selectively confirmed for other physical channel configurations (DPCCH & DPDCH_n), HSDPA and HSPA (HSUPA/HSDPA) modes according to output power, exposure conditions and device operating capabilities. Both uplink and downlink should be configured with the same RMC or AMR, when required. SAR for Release 5 HSDPA and Release 6 HSPA are measured using the applicable FRC (fixed reference channel) and E-DCH reference channel configurations. Maximum output power is verified according to applicable versions of 3GPP TS 34.121 and SAR must be measured according to these maximum output conditions. When Maximum Power Reduction (MPR) is not implemented according to Cubic Metric (CM) requirements for Release 6 HSPA, the following procedures do not apply.

For Release 5 HSDPA Data Devices:

Sub-test	β_c	β_d	β_d (SF)	β_c / β_d	β_{hs}	CM/dB
1	2/15	15/15	64	2/15	4/15	0.0
2	12/15	15/15	64	12/15	24/25	1.0
3	15/15	8/15	64	15/8	30/15	1.5
4	15/15	4/15	64	15/4	30/15	1.5

For Release 6 HSPA Data Devices

Sub-test	β_c	β_d	β_d (SF)	β_c / β_d	β_{hs}	β_{ec}	β_{ed}	β_{ed} (SF)	β_{ed} (codes)	CM (dB)	MPR (dB)	AG Index	E-TFCI
1	11/15	15/15	64	11/15	22/15	209/225	1039/225	4	1	1.0	0.0	20	75
2	6/15	15/15	64	6/15	12/15	12/15	12/15	4	1	3.0	2.0	12	67
3	15/15	9/15	64	15/9	30/15	30/15	$\beta_{ed1}:47/15$ $\beta_{ed2}:47/15$	4	2	2.0	1.0	15	92
4	2/15	15/15	64	2/15	4/15	4/15	56/75	4	1	3.0	2.0	17	71
5	15/15	15/15	64	15/15	24/15	30/15	134/15	4	1	1.0	0.0	21	81

9.4. SAR Measurement for LTE

SAR tests for LTE are performed with a base station simulator, Anristu MT8820C. Closed loop power control was used so the UE transmits with maximum output power during SAR testing. All powers were measured with the Anristu MT8820C. It is performed for conducted power and SAR based on the KDB941225 D05.

SAR is evaluated separately according to the following procedures for the different test positions in each exposure condition – head, body, body-worn accessories and other use conditions. The procedures in the following subsections are applied separately to test each LTE frequency band.

1) QPSK with 1 RB allocation

Start with the largest channel bandwidth and measure SAR for QPSK with 1 RB allocation, using the RB offset and required test channel combination with the highest maximum output power among RB offsets at the upper edge, middle and lower edge of each required test channel. When the reported SAR is ≤ 0.8 W/kg, testing of the remaining RB offset configurations and required test channels is not required for 1 RB allocation; otherwise, SAR is required for the remaining required test channels and only for the RB offset configuration with the highest output power for that channel. When the reported SAR of a required test channel is > 1.45 W/kg, SAR is required for all three RB offset configurations for that required test channel.

2) QPSK with 50% RB allocation

The procedures required for 1 RB allocation in 1) are applied to measure the SAR for QPSK with 50% RB allocation.

3) QPSK with 100% RB allocation

For QPSK with 100% RB allocation, SAR is not required when the highest maximum output power for 100% RB allocation is less than the highest maximum output power in 50% and 1 RB allocations and the highest reported SAR for 1 RB and 50% RB allocation in 1) and 2) are ≤ 0.8 W/kg. Otherwise, SAR is measured for the highest output power channel; and if the reported SAR is > 1.45 W/kg, the remaining required test channels must also be tested.

9.5. Bluetooth Measurement Procedures for SAR

Normal network operating configurations are not suitable for measuring the SAR of 802.11 transmitters in general. Unpredictable fluctuations in network traffic and antenna diversity conditions can introduce undesirable variations in SAR results. The SAR for these devices should be measured using chipset based test mode software to ensure that the results are consistent and reliable.

Chipset based test mode software is hardware dependent and generally varies among manufacturers. The device operating parameters established in a test mode for SAR measurements must be identical to those programmed in production units, including output power levels, amplifier gain settings and other RF performance tuning parameters. The test frequencies should correspond to actual channel frequencies defined for domestic use. SAR for devices with switched diversity should be measured with only one antenna transmitting at a time during each SAR measurement, according to a fixed modulation and data rate. The same data pattern should be used for all measurements.

9.6. Power Drift

To control the output power stability during the SAR test, DASY5 system calculates the power drift by measuring the E-field at the same location at the beginning and at the end of the measurement for each test position. These drift values can be found in Section 12 labeled as: (Power Drift [dB]). This ensures that the power drift during one measurement is within 5%.

10. Conducted Output Power

10.1. GSM Measurement result

Table 10.1: The conducted power measurement results GSM/GPRS

GSM850

GSM850 Speech	Tune up	Measured Power (dBm)			/			
		Ch.251	Ch.190	Ch.128				
1Tx slot	33.5	33.11	33.10	33.18				
GPRS 850	/	Measured timeslot-Averaged output Power (dBm)			calculation	Source-based time-Averaged output Power (dBm)		
		Ch.251	Ch.190	Ch.128		Ch.251	Ch.190	Ch.128
1Tx-slot	33.5	33.01	33.12	33.11	-9.03	23.98	24.09	24.08
2Tx-slots	32.0	30.78	30.99	31.04	-6.02	24.76	24.97	25.02
3Tx-slots	30.0	28.72	28.85	28.93	-4.26	24.46	24.59	24.67
4Tx-slots	27.0	26.61	26.73	26.82	-3.01	23.60	23.72	23.81

GSM1900

GSM1900 Speech	Tune up	Measured Power (dBm)			/			
		Ch.810	Ch.661	Ch.512				
1Tx slot	30.5	29.60	29.98	30.00				
GPRS 1900	/	Measured timeslot-Averaged output Power (dBm)			calculation	Source-based time-Averaged output Power (dBm)		
		Ch.810	Ch.661	Ch.512		Ch.810	Ch.661	Ch.512
1Tx-slot	30.5	29.71	29.98	29.98	-9.03	20.68	20.95	20.95
2Tx-slots	29.0	27.01	27.55	27.69	-6.02	20.99	21.53	21.67
3Tx-slots	27.0	25.26	25.79	26.01	-4.26	21.00	21.53	21.75
4Tx-slots	25.0	23.10	23.62	23.87	-3.01	20.09	20.61	20.86

10.2. WCDMA Measurement result

Table 10.2: The conducted power measurement results WCDMA

WCDMA Band 2

Item	Band	WCDMA Band 2 Result			
	ARFCN	Tune up	Ch.9538 (1907.6MHz)	Ch.9400 (1880MHz)	Ch.9262 (1852.4MHz)
WCDMA	12.2kbps RMC	23.5	22.83	22.84	22.80
HSUPA	1	23.0	22.15	22.20	22.12
	2	23.0	21.22	21.27	21.24
	3	23.0	22.00	22.15	22.07
	4	23.0	21.07	21.13	21.08
	5	23.0	22.01	22.08	22.07
HSDPA	1	23.0	22.25	22.30	22.14
	2	23.0	22.03	22.13	22.09
	3	23.0	21.49	21.56	21.42
	4	23.0	21.44	21.47	21.50

WCDMA Band 4

Item	Band	WCDMA Band 4 Result			
	ARFCN	Tune up	Ch.1513 (1752.6MHz)	Ch.1413 (1732.6MHz)	Ch.1312 (1712.4MHz)
WCDMA	12.2kbps RMC	23.5	22.40	22.43	22.33
HSUPA	1	23.0	21.96	22.05	21.93
	2	23.0	21.11	21.19	21.06
	3	23.0	21.84	21.97	21.92
	4	23.0	21.16	21.07	21.05
	5	23.0	21.85	21.93	21.92
HSDPA	1	23.0	22.04	22.11	21.98
	2	23.0	21.88	21.99	21.92
	3	23.0	21.34	21.40	21.22
	4	23.0	21.27	21.31	21.31



WCDMA Band 5

Item	Band	WCDMA Band 5 Result			
	ARFCN	Tune up	Ch.4233 (846.6MHz)	Ch.4183 (836.6MHz)	Ch.4132 (826.4MHz)
WCDMA	12.2kbps RMC	23.5	22.59	22.61	22.60
HSUPA	1	23.0	22.13	22.22	22.1
	2	23.0	21.18	21.29	21.23
	3	23.0	22.01	22.14	22.09
	4	23.0	21.10	21.14	21.12
	5	23.0	22.02	22.10	22.09
HSDPA	1	23.0	22.21	22.28	22.15
	2	23.0	22.05	22.16	22.09
	3	23.0	21.51	21.57	21.39
	4	23.0	21.44	21.48	21.48

10.3. LTE Measurement result

According to April 2015 TCB workshop, SAR Test exclusion can be applied for testing overlapping LTE Bands as follows:

- a) The maximum out power, including tolerance, for the smaller band must be \leq the larger band to qualify for SAR test exclusion.
- b) The channel bandwidth and other operating parameters for the smaller band must be fully supported by the larger band.

LTE Band 4 (1710-1755MHz) is covered by LTE Band 66 (1710-1780MHz)

LTE Band 17 (704-716MHz) is covered by LTE Band 12 (699-716MHz)



Table 10.3: The conducted Power for LTE

LTE Band 2

Bandwidth	Number of RBs	Frequency	QPSK	16QAM	QPSK Tune-up	16QAM Tune-up			
1.4MHz	1RB-High (5)	1909.3	22.51	22.77	23.5	23.0			
		1880.0	22.56	22.17					
		1850.7	22.44	22.03					
	1RB-Middle (3)	1909.3	22.49	22.85					
		1880.0	22.57	22.11					
		1850.7	22.38	22.04					
	1RB-Low (0)	1909.3	22.40	22.84					
		1880.0	22.39	22.18					
		1850.7	22.43	22.05					
	3RB-High (3)	1909.3	22.50	22.66					
		1880.0	22.50	22.24					
		1850.7	22.57	22.45					
	3RB-Middle (1)	1909.3	22.60	22.40					
		1880.0	22.58	22.19					
		1850.7	22.51	22.42					
	3RB-Low (0)	1909.3	22.58	22.39					
		1880.0	22.52	22.23					
		1850.7	22.56	22.44					
	6RB (0)	1909.3	22.05	21.12					
		1880.0	21.98	20.99					
		1850.7	22.15	20.93					
	3MHz	1RB-High (14)	1908.5	22.46			22.62	23.5	23.0
			1880.0	22.42			22.22		
			1851.5	22.51			22.69		
1RB-Middle (7)		1908.5	22.42	22.67					
		1880.0	22.42	22.19					
		1851.5	22.58	22.71					
1RB-Low (0)		1908.5	22.41	22.73					
		1880.0	22.49	22.14					
		1851.5	22.52	22.73					
8RB-High (7)		1908.5	22.16	21.34					
		1880.0	21.91	21.12					
		1851.5	21.98	21.27					
8RB-Middle (4)		1908.5	22.10	21.34					
		1880.0	21.96	21.17					
		1851.5	22.02	21.32					
8RB-Low (0)		1908.5	22.18	21.31					
		1880.0	21.95	21.21					
		1851.5	21.98	21.29					
15RB (0)		1908.5	22.12	21.33					
		1880.0	22.06	21.12					
		1851.5	22.10	21.25					
5MHz		1RB-High (24)	1907.5	22.54	22.68	23.5	23.0		
			1880.0	22.34	22.66				
			1852.5	22.49	22.58				
	1RB-Middle (12)	1907.5	22.59	22.80					
		1880.0	22.36	22.60					
		1852.5	22.47	22.65					
	1RB-Low (0)	1907.5	22.50	22.75					
		1880.0	22.40	22.70					
		1852.5	22.52	22.70					
	12RB-High (13)	1907.5	22.01	21.33					
		1880.0	21.85	21.16					
		1852.5	21.91	21.17					
	12RB-Middle (6)	1907.5	22.03	21.17					
		1880.0	22.03	21.14					
		1852.5	22.07	21.24					
	12RB-Low (0)	1907.5	22.05	21.19					
		1880.0	21.92	21.21					
		1852.5	21.93	21.24					
	25RB (0)	1907.5	22.05	21.40					
		1880.0	22.03	21.32					
		1852.5	21.94	21.28					
	10MHz	1RB-High (48)	1905.0	22.53	22.13			23.5	23.0
			1880.0	22.48	22.61				
			1855.0	22.49	22.61				
1RB-Middle (24)		1905.0	22.45	22.09					
		1880.0	22.47	22.56					
		1855.0	22.41	22.63					
1RB-Low (0)		1905.0	22.36	22.04					
		1880.0	22.49	22.71					
		1855.0	22.50	22.73					
25RB-High (25)		1905.0	21.97	21.36					
		1880.0	21.98	21.10					
		1855.0	21.94	21.04					
25RB-Middle (12)		1905.0	22.09	21.36					
		1880.0	22.01	21.04					
		1855.0	22.09	21.11					
25RB-Low (0)		1905.0	22.01	21.28					
		1880.0	21.92	21.04					
		1855.0	22.02	21.06					
50RB (0)		1905.0	22.03	21.23					
		1880.0	21.96	21.11					
		1855.0	22.07	21.10					
15MHz		1RB-High (74)	1902.5	22.43	22.63	23.5	23.0		
			1880.0	22.33	22.68				
			1857.5	22.40	22.55				
	1RB-Middle (37)	1902.5	22.35	22.61					
		1880.0	22.30	22.61					
		1857.5	22.51	22.64					
	1RB-Low (0)	1902.5	22.29	22.58					
		1880.0	22.40	22.67					
		1857.5	22.53	22.68					
	36RB-High (38)	1902.5	22.08	21.12					
		1880.0	22.00	21.05					
		1857.5	21.89	21.15					
	36RB-Middle (19)	1902.5	21.98	21.07					
		1880.0	21.89	21.07					
		1857.5	22.06	21.19					
	36RB-Low (0)	1902.5	21.97	21.13					
		1880.0	22.02	21.08					
		1857.5	22.05	21.18					
	75RB (0)	1902.5	22.05	21.12					
		1880.0	22.04	21.10					
		1857.5	21.96	21.06					
	20MHz	1RB-High (99)	1900.0	22.55	22.66			23.5	23.0
			1880.0	22.51	22.11				
			1860.0	22.41	22.64				
1RB-Middle (50)		1900.0	22.38	22.61					
		1880.0	22.43	22.09					
		1860.0	22.31	22.62					
1RB-Low (0)		1900.0	22.37	22.64					
		1880.0	22.49	22.21					
		1860.0	22.40	22.64					
50RB-High (50)		1900.0	21.96	21.14					
		1880.0	21.93	21.10					
		1860.0	22.01	21.02					
50RB-Middle (25)		1900.0	22.00	21.09					
		1880.0	21.95	21.08					
		1860.0	21.93	21.06					
50RB-Low (0)		1900.0	22.00	21.04					
		1880.0	22.05	21.17					
		1860.0	21.99	21.10					
100RB (0)		1900.0	21.99	21.08					
		1880.0	21.96	21.14					
		1860.0	22.01	21.03					



LTE Band 5

Bandwidth	Number of RBs	Frequency	QPSK	16QAM	QPSK Tune-up	16QAM Tune-up	
1.4MHz	1RB-High (5)	848.3	22.17	22.11	23.0	23.0	
		836.5	22.01	21.61			
		824.7	22.03	22.19			
	1RB-Middle (3)	848.3	22.15	22.22			
		836.5	22.12	21.69			
		824.7	22.09	22.17			
	1RB-Low (0)	848.3	22.15	22.20			
		836.5	22.03	21.59			
		824.7	22.03	22.05			
	3RB-High (3)	848.3	22.20	21.98			
		836.5	22.08	21.98			
		824.7	22.20	21.99			
	3RB-Middle (1)	848.3	22.31	21.92			
		836.5	22.12	22.07			
		824.7	22.20	22.02			
	3RB-Low (0)	848.3	22.24	21.93			
		836.5	22.08	22.03			
		824.7	22.18	22.01			
6RB (0)	848.3	21.66	20.49	23.0	22.0		
	836.5	21.60	20.56				
	824.7	21.69	20.53				
3MHz	1RB-High (14)	847.5	22.12	22.42	23.0	23.0	
		836.5	22.01	22.21			
		825.5	22.09	22.12			
	1RB-Middle (7)	847.5	22.10	22.39			
		836.5	22.16	22.23			
		825.5	22.13	22.05			
	1RB-Low (0)	847.5	22.15	22.43			
		836.5	22.02	22.23			
		825.5	22.06	22.12			
	8RB-High (7)	847.5	21.74	20.81		23.0	22.0
		836.5	21.63	20.77			
		825.5	21.72	20.82			
	8RB-Middle (4)	847.5	21.84	20.88			
		836.5	21.67	20.81			
		825.5	21.71	20.85			
	8RB-Low (0)	847.5	21.85	20.87			
		836.5	21.63	20.84			
		825.5	21.59	20.86			
15RB (0)	847.5	21.74	20.82				
	836.5	21.71	20.90				
	825.5	21.67	20.77				
5MHz	1RB-High (24)	846.5	22.11	21.79	23.0		23.0
		836.5	22.20	22.16			
		826.5	22.06	21.74			
	1RB-Middle (12)	846.5	22.12	21.78			
		836.5	22.15	22.29			
		826.5	22.05	21.74			
	1RB-Low (0)	846.5	22.07	21.84			
		836.5	22.13	22.25			
		826.5	21.98	21.74			
	12RB-High (13)	846.5	21.71	20.83		23.0	22.0
		836.5	21.61	20.80			
		826.5	21.75	20.83			
	12RB-Middle (6)	846.5	21.74	20.84			
		836.5	21.77	20.71			
		826.5	21.59	20.73			
	12RB-Low (0)	846.5	21.66	20.79			
		836.5	21.64	20.81			
		826.5	21.60	20.76			
25RB (0)	846.5	21.80	20.99				
	836.5	21.60	20.99				
	826.5	21.67	20.98				
10MHz	1RB-High (49)	844.0	22.12	22.39	23.0		23.0
		836.5	22.15	21.74			
		829.0	22.10	22.29			
	1RB-Middle (24)	844.0	22.11	22.33			
		836.5	21.96	21.74			
		829.0	22.09	22.22			
	1RB-Low (0)	844.0	22.05	22.22			
		836.5	21.99	21.72			
		829.0	22.03	22.25			
	25RB-High (25)	844.0	21.91	20.78		23.0	22.0
		836.5	21.73	21.46			
		829.0	21.86	20.79			
	25RB-Middle (12)	844.0	21.58	20.76			
		836.5	21.71	20.97			
		829.0	21.64	20.76			
	25RB-Low (0)	844.0	21.77	20.74			
		836.5	21.65	20.92			
		829.0	21.76	20.69			
50RB (0)	844.0	21.76	20.76				
	836.5	21.61	20.67				
	829.0	21.63	20.76				



LTE Band 7

Bandwidth	Number of RBs	Frequency	QPSK	16QAM	QPSK Tune-up	16QAM Tune-up		
5MHz	1RB-High (24)	2567.5	22.79	22.92	23.5	23.0		
		2535.0	22.60	22.80				
		2502.5	22.58	22.70				
	1RB-Middle (12)	2567.5	22.76	22.83				
		2535.0	22.64	22.56				
		2502.5	22.58	22.75				
	1RB-Low (0)	2567.5	22.77	22.85				
		2535.0	22.53	22.73				
		2502.5	22.51	22.68				
	12RB-High (13)	2567.5	22.35	21.32			23.0	22.0
		2535.0	22.22	21.28				
		2502.5	22.19	21.19				
		12RB-Middle (6)	2567.5	22.27	21.37			
			2535.0	22.20	21.26			
			2502.5	22.20	21.14			
		12RB-Low (0)	2567.5	22.29	21.41			
			2535.0	22.21	21.31			
			2502.5	22.20	21.19			
		25RB (0)	2567.5	22.26	21.62			
			2535.0	22.10	21.38			
			2502.5	22.23	21.27			
	10MHz	1RB-High (49)	2565.0	22.76	22.81	23.5	23.0	
			2535.0	22.62	22.17			
			2505.0	22.53	22.18			
1RB-Middle (24)		2565.0	22.77	22.93				
		2535.0	22.58	22.23				
		2505.0	22.51	22.15				
1RB-Low (0)		2565.0	22.77	22.95				
		2535.0	22.52	22.04				
		2505.0	22.54	22.13				
25RB-High (25)		2565.0	22.29	21.38	23.0			22.0
		2535.0	22.18	21.40				
		2505.0	22.16	21.32				
		25RB-Middle (12)	2565.0	22.41		21.21		
			2535.0	22.21		21.46		
			2505.0	22.19		21.37		
25RB-Low (0)		2565.0	22.38	21.34				
		2535.0	22.11	21.47				
		2505.0	22.14	21.37				
50RB (0)		2565.0	22.37	21.63				
		2535.0	22.26	21.13				
		2505.0	22.18	21.32				
15MHz		1RB-High (74)	2562.5	22.80	22.88	23.5	23.0	
			2535.0	22.59	22.86			
			2507.5	22.54	22.84			
	1RB-Middle (37)	2562.5	22.65	22.90				
		2535.0	22.59	22.77				
		2507.5	22.50	22.78				
	1RB-Low (0)	2562.5	22.54	22.87				
		2535.0	22.37	22.69				
		2507.5	22.48	22.86				
	36RB-High (38)	2562.5	22.48	21.54	23.0			22.0
		2535.0	22.17	21.15				
		2507.5	22.20	21.15				
		36RB-Middle (19)	2562.5	22.42		21.48		
			2535.0	22.20		21.08		
			2507.5	22.08		21.14		
	36RB-Low (0)	2562.5	22.30	21.54				
		2535.0	22.10	21.07				
		2507.5	22.11	21.11				
	75RB (0)	2562.5	22.42	21.31				
		2535.0	22.14	21.28				
		2507.5	22.01	21.23				
	20MHz	1RB-High (99)	2560.0	22.91	22.85	23.5	23.0	
			2535.0	22.79	22.42			
			2510.0	22.67	22.06			
1RB-Middle (50)		2560.0	22.78	22.77				
		2535.0	22.71	22.36				
		2510.0	22.57	22.06				
1RB-Low (0)		2560.0	22.60	22.94				
		2535.0	22.59	22.24				
		2510.0	22.49	22.07				
50RB-High (50)		2560.0	22.42	21.42	23.0			22.0
		2535.0	22.29	21.24				
		2510.0	22.23	21.24				
		50RB-Middle (25)	2560.0	22.29		21.49		
			2535.0	22.25		21.22		
			2510.0	22.10		21.18		
50RB-Low (0)		2560.0	22.30	21.29				
		2535.0	22.18	21.15				
		2510.0	22.12	21.42				
100RB (0)		2560.0	22.31	21.41				
		2535.0	22.03	21.18				
		2510.0	22.02	21.18				



LTE Band 12

Bandwidth	Number of RBs	Frequency	QPSK	16QAM	QPSK Tune-up	16QAM Tune-up		
1.4MHz	1RB-High (5)	715.3	22.18	21.68	23.5	23.0		
		707.5	22.07	22.18				
		699.7	21.98	21.64				
	1RB-Middle (3)	715.3	22.19	21.60				
		707.5	22.07	22.15				
		699.7	21.93	21.43				
	1RB-Low (0)	715.3	22.17	21.60				
		707.5	21.96	22.04				
		699.7	21.91	21.63				
	3RB-High (3)	715.3	22.34	21.98				
		707.5	22.12	21.89				
		699.7	22.04	21.87				
	3RB-Middle (1)	715.3	22.29	22.00				
		707.5	22.16	21.89				
		699.7	22.13	21.94				
	3RB-Low (0)	715.3	22.29	22.06				
		707.5	22.20	22.03				
		699.7	22.05	21.87				
6RB (0)	715.3	21.79	20.55	23.0	22.0			
	707.5	21.58	20.96					
	699.7	21.57	20.37					
3MHz	1RB-High (14)	714.5	22.22	22.33	23.5	23.0		
		707.5	22.01	22.09				
		700.5	22.04	21.71				
	1RB-Middle (7)	714.5	22.24	22.15				
		707.5	22.13	22.14				
		700.5	21.98	21.66				
	1RB-Low (0)	714.5	22.26	22.39				
		707.5	22.00	22.00				
		700.5	22.02	21.71				
	8RB-High (7)	714.5	21.82	21.00	23.0	22.0		
		707.5	21.61	21.21				
		700.5	21.69	21.30				
	8RB-Middle (4)	714.5	21.71	21.34				
		707.5	21.66	21.23				
		700.5	21.69	20.71				
	8RB-Low (0)	714.5	21.80	21.39				
		707.5	21.61	20.84				
		700.5	21.62	20.72				
15RB (0)	714.5	21.67	21.38					
	707.5	21.60	21.21					
	700.5	21.66	20.73					
5MHz	1RB-High (24)	713.5	22.16	22.21			23.5	23.0
		707.5	22.20	22.20				
		701.5	22.04	22.23				
	1RB-Middle (12)	713.5	22.06	22.31				
		707.5	22.14	22.13				
		701.5	22.07	22.30				
	1RB-Low (0)	713.5	22.13	22.34				
		707.5	22.04	22.11				
		701.5	21.93	22.03				
	12RB-High (13)	713.5	21.59	21.35	23.0	22.0		
		707.5	21.73	21.18				
		701.5	21.62	21.16				
	12RB-Middle (6)	713.5	21.70	21.36				
		707.5	21.67	21.15				
		701.5	21.76	21.14				
	12RB-Low (0)	713.5	21.75	20.79				
		707.5	21.55	20.63				
		701.5	21.57	20.74				
25RB (0)	713.5	21.77	21.50					
	707.5	21.74	21.18					
	701.5	21.58	21.14					
10MHz	1RB-High (49)	711.0	22.31	21.75			23.5	23.0
		707.5	22.18	22.29				
		704.0	22.20	22.15				
	1RB-Middle (24)	711.0	22.11	21.67				
		707.5	22.10	22.15				
		704.0	22.19	22.20				
	1RB-Low (0)	711.0	22.07	21.56				
		707.5	21.97	22.09				
		704.0	21.96	21.99				
	25RB-High (25)	711.0	21.71	21.31	23.0	22.0		
		707.5	21.78	20.80				
		704.0	21.81	20.77				
	25RB-Middle (12)	711.0	21.71	20.75				
		707.5	21.75	21.25				
		704.0	21.79	21.15				
	25RB-Low (0)	711.0	21.63	21.05				
		707.5	21.69	20.67				
		704.0	21.67	21.01				
50RB (0)	711.0	21.72	20.72					
	707.5	21.66	21.19					
	704.0	21.66	21.18					



LTE Band 13

Bandwidth	Number of RBs	Frequency	QPSK	16QAM	QPSK Tune-up	16QAM Tune-up
5MHz	1RB-High (24)	784.5	22.24	21.85	23.5	23.0
		782.0	22.25	21.79		
		779.5	22.23	22.23		
	1RB-Middle (12)	784.5	22.24	21.68		
		782.0	22.17	21.87		
		779.5	22.18	22.11		
	1RB-Low (0)	784.5	22.19	21.80		
		782.0	22.17	21.72		
		779.5	22.20	22.32		
	12RB-High (13)	784.5	21.80	21.04	23.0	22.0
		782.0	21.66	20.73		
		779.5	21.83	21.06		
	12RB-Middle (6)	784.5	21.82	20.81		
		782.0	21.80	21.03		
		779.5	21.77	20.97		
	12RB-Low (0)	784.5	21.72	20.74		
		782.0	21.74	21.04		
		779.5	21.78	21.20		
	25RB (0)	784.5	21.67	20.89		
		782.0	21.71	21.23		
		779.5	21.82	20.97		
10MHz	1RB-High (49)	782.0	22.17	22.21	23.5	23.5
	1RB-Middle (24)	782.0	22.23	22.20		
	1RB-Low (0)	782.0	22.28	22.11		
	25RB-High (25)	782.0	21.79	20.63	23.0	22.0
	25RB-Middle (12)	782.0	21.72	21.03		
	25RB-Low (0)	782.0	21.66	21.07		
	50RB (0)	782.0	21.89	21.12		



LTE Band 66

Bandwidth	Number of RBs	Frequency	QPSK	16QAM	QPSK Tune-up	16QAM Tune-up		
1.4MHz	1RB-High (5)	1779.3	22.28	22.03	23.5	23.0		
		1745.0	22.28	22.53				
		1710.7	22.31	22.56				
	1RB-Middle (3)	1779.3	22.24	22.11				
		1745.0	22.27	22.57				
		1710.7	22.29	22.35				
	1RB-Low (0)	1779.3	22.23	22.10				
		1745.0	22.30	22.40				
		1710.7	22.35	22.50				
	3RB-High (3)	1779.3	22.40	22.20				
		1745.0	22.42	22.17				
		1710.7	22.43	22.15				
	3RB-Middle (1)	1779.3	22.48	22.31				
		1745.0	22.37	22.14				
		1710.7	22.29	22.23				
	3RB-Low (0)	1779.3	22.43	22.27				
		1745.0	22.43	22.13				
		1710.7	22.39	22.17				
6RB (0)	1779.3	21.88	20.77	23.0	22.0			
	1745.0	21.89	20.88					
	1710.7	21.88	20.81					
3MHz	1RB-High (14)	1778.5	22.20	22.55	23.5	23.0		
		1745.0	22.31	22.14				
		1711.5	22.38	22.42				
	1RB-Middle (7)	1778.5	22.21	22.65				
		1745.0	22.32	22.10				
		1711.5	22.37	22.37				
	1RB-Low (0)	1778.5	22.26	22.58				
		1745.0	22.32	22.07				
		1711.5	22.41	22.49				
	8RB-High (7)	1778.5	22.01	21.04			23.0	22.0
		1745.0	21.93	21.12				
		1711.5	21.90	21.11				
	8RB-Middle (4)	1778.5	21.88	21.13				
		1745.0	21.95	21.08				
		1711.5	21.83	21.12				
	8RB-Low (0)	1778.5	21.90	21.19				
		1745.0	21.93	21.11				
		1711.5	21.75	21.07				
15RB (0)	1778.5	21.98	21.09					
	1745.0	21.78	21.19					
	1711.5	21.78	21.09					
5MHz	1RB-High (24)	1777.5	22.26	22.50	23.5	23.0		
		1745.0	22.22	22.61				
		1712.5	22.21	22.47				
	1RB-Middle (12)	1777.5	22.25	22.56				
		1745.0	22.17	22.56				
		1712.5	22.12	22.47				
	1RB-Low (0)	1777.5	22.28	22.45				
		1745.0	22.22	22.52				
		1712.5	22.19	22.46				
	12RB-High (13)	1777.5	21.96	20.98			23.0	22.0
		1745.0	21.93	21.07				
		1712.5	21.79	21.01				
	12RB-Middle (6)	1777.5	21.99	21.06				
		1745.0	21.73	20.95				
		1712.5	21.78	20.98				
	12RB-Low (0)	1777.5	21.93	21.13				
		1745.0	21.95	20.91				
		1712.5	21.87	21.04				
25RB (0)	1777.5	21.85	20.93					
	1745.0	21.95	21.17					
	1712.5	21.95	20.86					
10MHz	1RB-High (49)	1775.0	22.40	22.02	23.5	23.0		
		1745.0	22.35	22.44				
		1715.0	22.30	22.56				
	1RB-Middle (24)	1775.0	22.37	22.01				
		1745.0	22.34	22.37				
		1715.0	22.31	22.57				
	1RB-Low (0)	1775.0	22.37	21.99				
		1745.0	22.42	22.43				
		1715.0	22.36	22.44				
	25RB-High (25)	1775.0	21.91	20.95			23.0	22.0
		1745.0	21.83	20.89				
		1715.0	21.79	21.11				
	25RB-Middle (12)	1775.0	21.89	20.91				
		1745.0	21.76	20.97				
		1715.0	21.90	21.15				
	25RB-Low (0)	1775.0	21.95	20.92				
		1745.0	21.83	20.93				
		1715.0	21.77	21.12				
50RB (0)	1775.0	21.92	21.07					
	1745.0	21.74	20.99					
	1715.0	21.78	20.90					
15MHz	1RB-High (74)	1772.5	22.32	22.63	23.5	23.0		
		1745.0	22.39	22.42				
		1717.5	22.23	22.41				
	1RB-Middle (37)	1772.5	22.35	22.54				
		1745.0	22.30	22.43				
		1717.5	22.16	22.38				
	1RB-Low (0)	1772.5	22.42	22.54				
		1745.0	22.38	22.42				
		1717.5	22.23	22.41				
	36RB-High (38)	1772.5	21.96	21.09			23.0	22.0
		1745.0	21.83	20.91				
		1717.5	21.91	20.92				
	36RB-Middle (19)	1772.5	21.93	21.09				
		1745.0	21.90	20.89				
		1717.5	21.84	20.91				
	36RB-Low (0)	1772.5	21.96	21.14				
		1745.0	21.84	20.93				
		1717.5	21.79	20.97				
75RB (0)	1772.5	21.83	21.14					
	1745.0	21.81	21.06					
	1717.5	21.92	20.93					
20MHz	1RB-High (99)	1770.0	22.20	22.50	23.5	23.0		
		1745.0	22.15	22.44				
		1720.0	22.20	22.48				
	1RB-Middle (50)	1770.0	22.13	22.33				
		1745.0	22.22	22.60				
		1720.0	22.16	22.45				
	1RB-Low (0)	1770.0	22.24	22.35				
		1745.0	22.23	22.37				
		1720.0	22.22	22.54				
	50RB-High (50)	1770.0	21.75	20.96			23.0	22.0
		1745.0	21.84	20.96				
		1720.0	21.74	20.92				
	50RB-Middle (25)	1770.0	21.76	20.95				
		1745.0	21.71	20.97				
		1720.0	21.79	20.85				
	50RB-Low (0)	1770.0	21.76	21.02				
		1745.0	21.76	21.01				
		1720.0	21.80	20.95				
100RB (0)	1770.0	21.89	20.98					
	1745.0	21.80	21.03					
	1720.0	21.75	20.92					

10.4. Bluetooth Measurement result

Table 10.4: The conducted Power measurement results for Bluetooth

Bluetooth

Averaged Power (dBm)_ Duty Cycle: 77.16%				
Mode	Tune up	Ch.0 (2402MHz)	Ch.39 (2441MHz)	Ch.78 (2480MHz)
GFSK	5.5	4.13	4.28	4.37
EDR2M-4_DQPSK	7.0	5.01	5.68	5.89
EDR3M-8DPSK	7.5	5.07	5.77	6.12

11. Simultaneous TX SAR Considerations

11.1. Introduction

The following procedures adopted from “FCC SAR Considerations for Cell Phones with Multiple Transmitters” are applicable to handsets with built-in unlicensed transmitters such as 802.11 a/b/g and Bluetooth devices which may simultaneously transmit with the licensed transmitter. For this device, the Bluetooth can transmit simultaneous with other transmitters.

11.2. Transmit Antenna Separation Distances

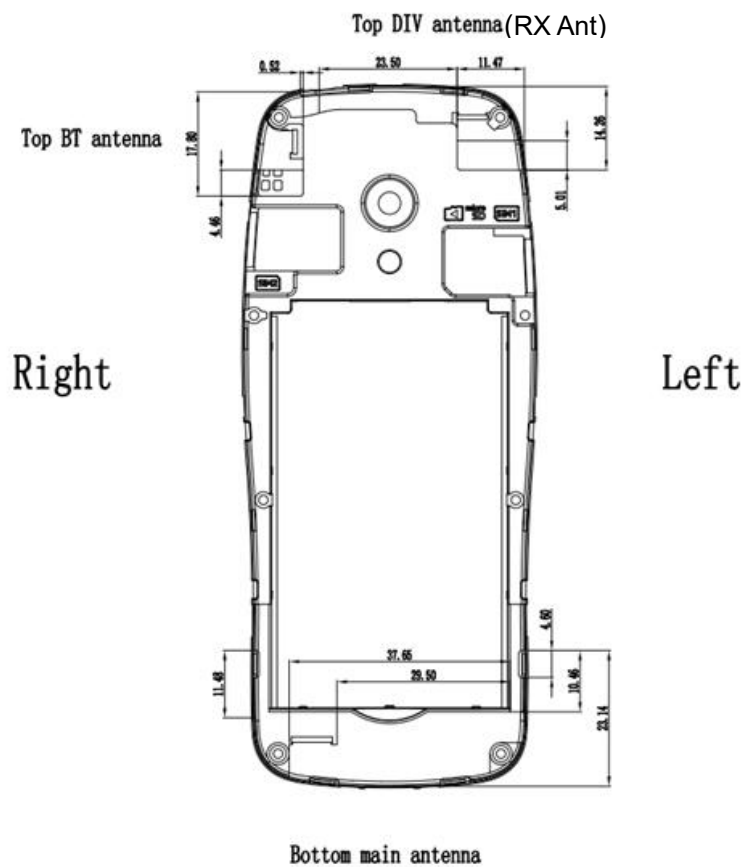

Picture 11.1 Antenna Locations (Back View)

11.3. Evaluation of Simultaneous

No.	Simultaneous Transmission Configuration
1	WWAN + Bluetooth

Table 12.1: Maximum Simultaneous Transmission SAR

/	Position	Sum (W/kg)
Highest reported SAR value for Head	Left Cheek (LTE Band 5 + Bluetooth)	1.47
Highest reported SAR value for Body-worn	Rear Side (WCDMA Band 5 + Bluetooth)	1.14

Note: the test positions of above tables are for the worse case that has been evaluated.

Conclusion:

According to the above tables, the sum of reported SAR values is less than limit. So the simultaneous transmission SAR with volume scans is not required.

12. Summary of Test Results

According to the client's decision rule in the test registration form, which is "based on the measurement results as the basis of the conformity statement", the test conclusion of this report meets the limit requirements.

The calculated SAR is obtained by the following formula:

$$\text{Calculated SAR} = \text{Measured SAR} \times 10^{(P_{\text{Target}} - P_{\text{Measured}})/10}$$

Where P_{Target} is the power of manufacturing upper limit;

P_{Measured} is the measured power in chapter 10.

Note:

1. The device support dual SIMs, SIM1 was used for the all configuration SAR testing and SIM2 test the worst case SAR of SIM1.
2. B2 (Battery): BA-L4M (Guangdong Fenghua New Energy Co., Ltd.)
3. C2: Configuration2

Duty Cycle

Mode	Duty Cycle
GSM	1:8.3
GPRS	1:4 / 1:2.67
WCDMA	1:1
FDD_LTE	1:1
Bluetooth	1:1.3

12.1. Testing Environment

Temperature:	18°C~25°C
Relative humidity:	30%~70%
Ambient noise & Reflection:	< 0.012 W/kg

12.2. Test Results

Table 12.1: GSM 850 SAR Values

RF Exposure Conditions	Frequency Band	Channel Number	Frequency (MHz)	Mode/RB	Test Position	Distance	Note	Figure No.	EUT Measured Power (dBm)	Tune up (dBm)	Duty Cycle %	Duty Cycle Scaling Factor	Measured SAR 1g (W/kg)	Calculated SAR 1g (W/kg)	Measured SAR 10g (W/kg)	Calculated SAR 10g (W/kg)	Power Drift
Head	GSM850	128	824.2	Speech	Left Cheek	0mm	\	\	33.18	33.50	\	\	0.504	0.54	0.371	0.40	-0.01
Head	GSM850	128	824.2	Speech	Left Tilt	0mm	\	\	33.18	33.50	\	\	0.322	0.35	0.235	0.25	0.13
Head	GSM850	128	824.2	Speech	Right Cheek	0mm	\	\	33.18	33.50	\	\	0.536	0.58	0.379	0.41	0.19
Head	GSM850	128	824.2	Speech	Right Tilt	0mm	\	\	33.18	33.50	\	\	0.334	0.36	0.239	0.26	-0.17
Head	GSM850	128	824.2	Speech	Left Cheek	0mm	C2	\	33.18	33.50	\	\	0.668	0.72	0.490	0.53	0.05
Head	GSM850	128	824.2	Speech	Left Tilt	0mm	C2	\	33.18	33.50	\	\	0.370	0.40	0.283	0.30	-0.04
Head	GSM850	128	824.2	Speech	Right Cheek	0mm	C2	1	33.18	33.50	\	\	0.713	0.77	0.528	0.57	0.06
Head	GSM850	128	824.2	Speech	Right Tilt	0mm	C2	\	33.18	33.50	\	\	0.395	0.43	0.298	0.32	-0.15
Body-Worn	GSM850	128	824.2	GPRS(2TX)	Front	15mm	\	\	31.04	32.00	\	\	0.654	0.82	0.444	0.55	0.01
Body-Worn	GSM850	128	824.2	GPRS(2TX)	Rear	15mm	\	2	31.04	32.00	\	\	0.740	0.92	0.529	0.66	0.08
Body-Worn	GSM850	251	848.8	GPRS(2TX)	Front	15mm	\	\	30.78	32.00	\	\	0.499	0.66	0.339	0.45	-0.14
Body-Worn	GSM850	190	836.6	GPRS(2TX)	Front	15mm	\	\	30.99	32.00	\	\	0.590	0.74	0.404	0.51	0.17
Body-Worn	GSM850	251	848.8	GPRS(2TX)	Rear	15mm	\	\	30.78	32.00	\	\	0.662	0.88	0.451	0.60	-0.05
Body-Worn	GSM850	190	836.6	GPRS(2TX)	Rear	15mm	\	\	30.99	32.00	\	\	0.645	0.81	0.439	0.55	-0.19
Body-Worn	GSM850	128	824.2	GPRS(2TX)	Rear	15mm	C2	\	31.04	32.00	\	\	0.697	0.87	0.500	0.62	0.16

Table 12.2: GSM 1900 SAR Values

RF Exposure Conditions	Frequency Band	Channel Number	Frequency (MHz)	Mode/RB	Test Position	Distance	Note	Figure No.	EUT Measured Power (dBm)	Tune up (dBm)	Duty Cycle %	Duty Cycle Scaling Factor	Measured SAR 1g (W/kg)	Calculated SAR 1g (W/kg)	Measured SAR 10g (W/kg)	Calculated SAR 10g (W/kg)	Power Drift
Head	GSM1900	512	1850.2	Speech	Left Cheek	0mm	\	\	30.00	30.50	\	\	0.148	0.17	0.097	0.11	-0.11
Head	GSM1900	512	1850.2	Speech	Left Tilt	0mm	\	\	30.00	30.50	\	\	0.077	0.09	0.046	0.05	0.03
Head	GSM1900	512	1850.2	Speech	Right Cheek	0mm	\	\	30.00	30.50	\	\	0.173	0.19	0.117	0.13	-0.10
Head	GSM1900	512	1850.2	Speech	Right Tilt	0mm	\	\	30.00	30.50	\	\	0.092	0.10	0.057	0.06	0.12
Head	GSM1900	512	1850.2	Speech	Right Cheek	0mm	C2	3	30.00	30.50	\	\	0.202	0.23	0.136	0.15	0.02
Body-Worn	GSM1900	512	1850.2	GPRS(3TX)	Front	15mm	\	\	26.01	27.00	\	\	0.267	0.34	0.162	0.20	-0.13
Body-Worn	GSM1900	512	1850.2	GPRS(3TX)	Rear	15mm	\	\	26.01	27.00	\	\	0.387	0.49	0.218	0.27	0.04
Body-Worn	GSM1900	512	1850.2	GPRS(3TX)	Rear	15mm	C2	4	26.01	27.00	\	\	0.402	0.50	0.228	0.29	0.01

Table 12.3: WCDMA Band 2 SAR Values

RF Exposure Conditions	Frequency Band	Channel Number	Frequency (MHz)	Mode/RB	Test Position	Distance	Note	Figure No.	EUT Measured Power (dBm)	Tune up (dBm)	Duty Cycle %	Duty Cycle Scaling Factor	Measured SAR 1g (W/kg)	Calculated SAR 1g (W/kg)	Measured SAR 10g (W/kg)	Calculated SAR 10g (W/kg)	Power Drift
Head	WCDMA Band 2	9400	1880.0	RMC	Left Cheek	0mm	\	\	22.84	23.50	\	\	0.279	0.32	0.180	0.21	-0.02
Head	WCDMA Band 2	9400	1880.0	RMC	Left Tilt	0mm	\	\	22.84	23.50	\	\	0.102	0.12	0.061	0.07	-0.04
Head	WCDMA Band 2	9400	1880.0	RMC	Right Cheek	0mm	\	\	22.84	23.50	\	\	0.309	0.36	0.218	0.25	-0.10
Head	WCDMA Band 2	9400	1880.0	RMC	Right Tilt	0mm	\	\	22.84	23.50	\	\	0.144	0.17	0.083	0.10	-0.03
Head	WCDMA Band 2	9400	1880.0	RMC	Right Cheek	0mm	C2	5	22.84	23.50	\	\	0.409	0.48	0.268	0.31	0.01
Body-Worn	WCDMA Band 2	9400	1880.0	RMC	Front	15mm	\	\	22.84	23.50	\	\	0.385	0.45	0.236	0.27	0.08
Body-Worn	WCDMA Band 2	9400	1880.0	RMC	Rear	15mm	\	\	22.84	23.50	\	\	0.645	0.75	0.365	0.42	0.03
Body-Worn	WCDMA Band 2	9400	1880.0	RMC	Rear	15mm	C2	\	22.84	23.50	\	\	0.596	0.69	0.339	0.39	0.12

Table 12.4: WCDMA Band 4 SAR Values

RF Exposure Conditions	Frequency Band	Channel Number	Frequency (MHz)	Mode/RB	Test Position	Distance	Note	Figure No.	EUT Measured Power (dBm)	Tune up (dBm)	Duty Cycle %	Duty Cycle Scaling Factor	Measured SAR 1g (W/kg)	Calculated SAR 1g (W/kg)	Measured SAR 10g (W/kg)	Calculated SAR 10g (W/kg)	Power Drift
Head	WCDMA Band 4	1413	1732.6	RMC	Left Cheek	0mm	\	\	22.43	23.50	\	\	0.171	0.22	0.112	0.14	0.07
Head	WCDMA Band 4	1413	1732.6	RMC	Left Tilt	0mm	\	\	22.43	23.50	\	\	0.093	0.12	0.058	0.07	-0.11
Head	WCDMA Band 4	1413	1732.6	RMC	Right Cheek	0mm	\	\	22.43	23.50	\	\	0.277	0.35	0.188	0.24	0.13
Head	WCDMA Band 4	1413	1732.6	RMC	Right Tilt	0mm	\	\	22.43	23.50	\	\	0.127	0.16	0.079	0.10	0.07
Head	WCDMA Band 4	1413	1732.6	RMC	Right Cheek	0mm	C2	7	22.43	23.50	\	\	0.361	0.46	0.242	0.31	0.02
Body-Worn	WCDMA Band 4	1413	1732.6	RMC	Front	15mm	\	\	22.43	23.50	\	\	0.313	0.40	0.191	0.24	-0.10
Body-Worn	WCDMA Band 4	1413	1732.6	RMC	Rear	15mm	\	\	22.43	23.50	\	\	0.686	0.88	0.396	0.51	0.02
Body-Worn	WCDMA Band 4	1513	1752.6	RMC	Rear	15mm	\	\	22.40	23.50	\	\	0.642	0.83	0.370	0.48	0.07
Body-Worn	WCDMA Band 4	1312	1712.4	RMC	Rear	15mm	\	8	22.33	23.50	\	\	0.784	1.03	0.451	0.59	-0.12
Body-Worn	WCDMA Band 4	1312	1712.4	RMC	Rear	15mm	SIM2	\	22.33	23.50	\	\	0.766	1.00	0.410	0.54	-0.07
Body-Worn	WCDMA Band 4	1312	1712.4	RMC	Rear	15mm	B2	\	22.33	23.50	\	\	0.771	1.01	0.428	0.56	0.03
Body-Worn	WCDMA Band 4	1312	1712.4	RMC	Rear	15mm	C2	\	22.33	23.50	\	\	0.757	0.99	0.439	0.57	0.09

Table 12.5: WCDMA Band 5 SAR Values

RF Exposure Conditions	Frequency Band	Channel Number	Frequency (MHz)	Mode/RB	Test Position	Distance	Note	Figure No.	EUT Measured Power (dBm)	Tune up (dBm)	Duty Cycle %	Duty Cycle Scaling Factor	Measured SAR 1g (W/kg)	Calculated SAR 1g (W/kg)	Measured SAR 10g (W/kg)	Calculated SAR 10g (W/kg)	Power Drift
Head	WCDMA Band 5	4183	836.4	RMC	Left Cheek	0mm	\	\	22.61	23.50	\	\	0.563	0.69	0.410	0.50	0.16
Head	WCDMA Band 5	4183	836.4	RMC	Left Tilt	0mm	\	\	22.61	23.50	\	\	0.261	0.32	0.186	0.23	0.14
Head	WCDMA Band 5	4183	836.4	RMC	Right Cheek	0mm	\	\	22.61	23.50	\	\	0.542	0.67	0.381	0.47	0.10
Head	WCDMA Band 5	4183	836.4	RMC	Right Tilt	0mm	\	\	22.61	23.50	\	\	0.288	0.35	0.206	0.25	-0.13
Head	WCDMA Band 5	4183	836.4	RMC	Left Cheek	0mm	C2	9	22.61	23.50	\	\	0.785	0.96	0.578	0.71	-0.08
Head	WCDMA Band 5	4183	836.4	RMC	Left Tilt	0mm	C2	\	22.61	23.50	\	\	0.364	0.45	0.262	0.32	-0.17
Head	WCDMA Band 5	4183	836.4	RMC	Right Cheek	0mm	C2	\	22.61	23.50	\	\	0.756	0.93	0.537	0.66	-0.07
Head	WCDMA Band 5	4183	836.4	RMC	Right Tilt	0mm	C2	\	22.61	23.50	\	\	0.402	0.49	0.290	0.36	0.02
Head	WCDMA Band 5	4233	846.6	RMC	Left Cheek	0mm	C2	\	22.59	23.50	\	\	0.762	0.94	0.571	0.70	-0.01
Head	WCDMA Band 5	4132	826.4	RMC	Left Cheek	0mm	C2	\	22.60	23.50	\	\	0.773	0.95	0.558	0.69	0.06
Body-Worn	WCDMA Band 5	4183	836.4	RMC	Front	15mm	\	\	22.61	23.50	\	\	0.399	0.49	0.272	0.33	0.04
Body-Worn	WCDMA Band 5	4183	836.4	RMC	Rear	15mm	\	\	22.61	23.50	\	\	0.431	0.53	0.297	0.36	0.08
Body-Worn	WCDMA Band 5	4183	836.4	RMC	Front	15mm	C2	\	22.61	23.50	\	\	0.636	0.78	0.469	0.58	0.03
Body-Worn	WCDMA Band 5	4183	836.4	RMC	Rear	15mm	C2	\	22.61	23.50	\	\	0.793	0.97	0.570	0.70	0.08
Body-Worn	WCDMA Band 5	4233	846.6	RMC	Rear	15mm	C2	10	22.59	23.50	\	\	0.927	1.14	0.678	0.84	0.10
Body-Worn	WCDMA Band 5	4132	826.4	RMC	Rear	15mm	C2	\	22.60	23.50	\	\	0.705	0.87	0.514	0.63	0.07

Table 12.6: LTE Band 2 SAR Values

RF Exposure Conditions	Frequency Band	Channel Number	Frequency (MHz)	Mode/RB	Test Position	Distance	Note	Figure No.	EUT Measured Power (dBm)	Tune up (dBm)	Duty Cycle %	Duty Cycle Scaling Factor	Measured SAR 1g (W/kg)	Calculated SAR 1g (W/kg)	Measured SAR 10g (W/kg)	Calculated SAR 10g (W/kg)	Power Drift
Head	LTE Band 2	19100	1900.0	1RB99	Left Cheek	0mm	\	\	22.55	23.50	\	\	0.277	0.34	0.178	0.22	0.03
Head	LTE Band 2	18900	1880.0	50RB0	Left Cheek	0mm	\	\	22.05	23.00	\	\	0.253	0.31	0.165	0.21	0.08
Head	LTE Band 2	19100	1900.0	1RB99	Left Tilt	0mm	\	\	22.55	23.50	\	\	0.105	0.13	0.070	0.09	0.14
Head	LTE Band 2	18900	1880.0	50RB0	Left Tilt	0mm	\	\	22.05	23.00	\	\	0.113	0.14	0.071	0.09	0.06
Head	LTE Band 2	19100	1900.0	1RB99	Right Cheek	0mm	\	\	22.55	23.50	\	\	0.418	0.52	0.277	0.34	-0.02
Head	LTE Band 2	18900	1880.0	50RB0	Right Cheek	0mm	\	\	22.05	23.00	\	\	0.348	0.43	0.224	0.28	0.05
Head	LTE Band 2	19100	1900.0	1RB99	Right Tilt	0mm	\	\	22.55	23.50	\	\	0.128	0.16	0.082	0.10	0.13
Head	LTE Band 2	18900	1880.0	50RB0	Right Tilt	0mm	\	\	22.05	23.00	\	\	0.147	0.18	0.084	0.10	0.18
Head	LTE Band 2	19100	1900.0	1RB99	Right Cheek	0mm	C2	11	22.55	23.50	\	\	0.485	0.60	0.307	0.38	0.06
Body-Worn	LTE Band 2	19100	1900.0	1RB99	Front	15mm	\	\	22.55	23.50	\	\	0.338	0.42	0.201	0.25	-0.04
Body-Worn	LTE Band 2	18900	1880.0	50RB0	Front	15mm	\	\	22.05	23.00	\	\	0.284	0.35	0.176	0.22	0.04
Body-Worn	LTE Band 2	19100	1900.0	1RB99	Rear	15mm	\	12	22.55	23.50	\	\	0.685	0.85	0.390	0.49	0.05
Body-Worn	LTE Band 2	18900	1880.0	50RB0	Rear	15mm	\	\	22.05	23.00	\	\	0.613	0.76	0.347	0.43	-0.14
Body-Worn	LTE Band 2	18900	1880.0	1RB99	Rear	15mm	\	\	22.51	23.50	\	\	0.646	0.81	0.365	0.46	-0.18
Body-Worn	LTE Band 2	18700	1860.0	1RB99	Rear	15mm	\	\	22.41	23.50	\	\	0.665	0.85	0.374	0.48	0.18
Body-Worn	LTE Band 2	18700	1860.0	100RB0	Rear	15mm	\	\	22.01	23.00	\	\	0.488	0.61	0.268	0.34	0.03
Body-Worn	LTE Band 2	19100	1900.0	1RB99	Rear	15mm	C2	\	22.55	23.50	\	\	0.614	0.76	0.353	0.44	0.02



Table 12.9: LTE Band 12 SAR Values

RF Exposure Conditions	Frequency Band	Channel Number	Frequency (MHz)	Mode/RB	Test Position	Distance	Note	Figure No.	EUT Measured Power (dBm)	Tune up (dBm)	Duty Cycle %	Duty Cycle Scaling Factor	Measured SAR 1g (W/kg)	Calculated SAR 1g (W/kg)	Measured SAR 10g (W/kg)	Calculated SAR 10g (W/kg)	Power Drift
Head	LTE Band 12	23130	711.0	1RB49	Left Cheek	0mm	\	\	22.31	23.50	\	\	0.324	0.43	0.238	0.31	0.01
Head	LTE Band 12	23060	704.0	25RB25	Left Cheek	0mm	\	\	21.81	23.00	\	\	0.278	0.37	0.205	0.27	0.18
Head	LTE Band 12	23130	711.0	1RB49	Left Tilt	0mm	\	\	22.31	23.50	\	\	0.187	0.25	0.138	0.18	0.04
Head	LTE Band 12	23060	704.0	25RB25	Left Tilt	0mm	\	\	21.81	23.00	\	\	0.173	0.23	0.128	0.17	-0.11
Head	LTE Band 12	23130	711.0	1RB49	Right Cheek	0mm	\	\	22.31	23.50	\	\	0.295	0.39	0.215	0.28	-0.01
Head	LTE Band 12	23060	704.0	25RB25	Right Cheek	0mm	\	\	21.81	23.00	\	\	0.259	0.34	0.190	0.25	0.01
Head	LTE Band 12	23130	711.0	1RB49	Right Tilt	0mm	\	\	22.31	23.50	\	\	0.172	0.23	0.125	0.16	0.04
Head	LTE Band 12	23060	704.0	25RB25	Right Tilt	0mm	\	\	21.81	23.00	\	\	0.168	0.22	0.121	0.16	-0.11
Head	LTE Band 12	23130	711.0	1RB49	Left Cheek	0mm	C2	17	22.31	23.50	\	\	0.389	0.51	0.289	0.38	0.05
Body-Worn	LTE Band 12	23130	711.0	1RB49	Front	15mm	\	\	22.31	23.50	\	\	0.198	0.26	0.143	0.19	0.07
Body-Worn	LTE Band 12	23060	704.0	25RB25	Front	15mm	\	\	21.81	23.00	\	\	0.175	0.23	0.126	0.17	0.06
Body-Worn	LTE Band 12	23130	711.0	1RB49	Rear	15mm	\	18	22.31	23.50	\	\	0.308	0.41	0.220	0.29	0.16
Body-Worn	LTE Band 12	23060	704.0	25RB25	Rear	15mm	\	\	21.81	23.00	\	\	0.300	0.39	0.215	0.28	-0.12
Body-Worn	LTE Band 12	23130	711.0	1RB49	Rear	15mm	C2	\	22.31	23.50	\	\	0.290	0.38	0.207	0.27	-0.05

Note: SAR for LTE Band 17 is covered by LTE Band 12 due to similar frequency range, same maximum tune-up limit and same channel bandwidth.

Table 12.10: LTE Band 13 SAR Values

RF Exposure Conditions	Frequency Band	Channel Number	Frequency (MHz)	Mode/RB	Test Position	Distance	Note	Figure No.	EUT Measured Power (dBm)	Tune up (dBm)	Duty Cycle %	Duty Cycle Scaling Factor	Measured SAR 1g (W/kg)	Calculated SAR 1g (W/kg)	Measured SAR 10g (W/kg)	Calculated SAR 10g (W/kg)	Power Drift
Head	LTE Band 13	23230	782.0	1RB0	Left Cheek	0mm	\	\	22.28	23.50	\	\	0.691	0.92	0.503	0.67	0.04
Head	LTE Band 13	23230	782.0	25RB25	Left Cheek	0mm	\	\	21.79	23.00	\	\	0.621	0.82	0.441	0.58	0.05
Head	LTE Band 13	23230	782.0	1RB0	Left Tilt	0mm	\	\	22.28	23.50	\	\	0.369	0.49	0.264	0.35	-0.05
Head	LTE Band 13	23230	782.0	25RB25	Left Tilt	0mm	\	\	21.79	23.00	\	\	0.349	0.46	0.249	0.33	-0.13
Head	LTE Band 13	23230	782.0	1RB0	Right Cheek	0mm	\	\	22.28	23.50	\	\	0.586	0.78	0.415	0.55	0.10
Head	LTE Band 13	23230	782.0	25RB25	Right Cheek	0mm	\	\	21.79	23.00	\	\	0.574	0.76	0.405	0.54	-0.14
Head	LTE Band 13	23230	782.0	1RB0	Right Tilt	0mm	\	\	22.28	23.50	\	\	0.339	0.45	0.243	0.32	0.16
Head	LTE Band 13	23230	782.0	25RB25	Right Tilt	0mm	\	\	21.79	23.00	\	\	0.316	0.42	0.225	0.30	0.11
Head	LTE Band 13	23230	782.0	50RB0	Left Cheek	0mm	\	\	21.89	23.00	\	\	0.522	0.67	0.370	0.48	0.05
Head	LTE Band 13	23230	782.0	1RB0	Left Cheek	0mm	C2	19	22.28	23.50	\	\	0.768	1.02	0.559	0.74	-0.11
Body-Worn	LTE Band 13	23230	782.0	1RB0	Front	15mm	\	\	22.28	23.50	\	\	0.484	0.64	0.353	0.47	0.05
Body-Worn	LTE Band 13	23230	782.0	25RB25	Front	15mm	\	\	21.79	23.00	\	\	0.464	0.61	0.333	0.44	0.03
Body-Worn	LTE Band 13	23230	782.0	1RB0	Rear	15mm	\	20	22.28	23.50	\	\	0.647	0.86	0.465	0.62	0.15
Body-Worn	LTE Band 13	23230	782.0	25RB25	Rear	15mm	\	\	21.79	23.00	\	\	0.631	0.83	0.454	0.60	0.16
Body-Worn	LTE Band 13	23230	782.0	50RB0	Rear	15mm	\	\	21.89	23.00	\	\	0.509	0.66	0.345	0.45	0.03
Body-Worn	LTE Band 13	23230	782.0	1RB0	Rear	15mm	C2	\	22.28	23.50	\	\	0.567	0.75	0.403	0.53	0.06

Table 12.11: LTE Band 66 SAR Values

RF Exposure Conditions	Frequency Band	Channel Number	Frequency (MHz)	Mode/RB	Test Position	Distance	Note	Figure No.	EUT Measured Power (dBm)	Tune up (dBm)	Duty Cycle %	Duty Cycle Scaling Factor	Measured SAR 1g (W/kg)	Calculated SAR 1g (W/kg)	Measured SAR 10g (W/kg)	Calculated SAR 10g (W/kg)	Power Drift
Head	LTE Band 66	132572	1770.0	1RB0	Left Cheek	0mm	\	\	22.24	23.50	\	\	0.196	0.26	0.129	0.17	-0.02
Head	LTE Band 66	132322	1745.0	50RB25	Left Cheek	0mm	\	\	21.84	23.00	\	\	0.171	0.22	0.112	0.15	0.00
Head	LTE Band 66	132572	1770.0	1RB0	Left Tilt	0mm	\	\	22.24	23.50	\	\	0.084	0.11	0.053	0.07	0.13
Head	LTE Band 66	132322	1745.0	50RB25	Left Tilt	0mm	\	\	21.84	23.00	\	\	0.079	0.10	0.049	0.06	-0.04
Head	LTE Band 66	132572	1770.0	1RB0	Right Cheek	0mm	\	21	22.24	23.50	\	\	0.293	0.39	0.198	0.26	0.07
Head	LTE Band 66	132322	1745.0	50RB25	Right Cheek	0mm	\	\	21.84	23.00	\	\	0.242	0.32	0.160	0.21	0.01
Head	LTE Band 66	132572	1770.0	1RB0	Right Tilt	0mm	\	\	22.24	23.50	\	\	0.118	0.16	0.074	0.10	-0.05
Head	LTE Band 66	132322	1745.0	50RB25	Right Tilt	0mm	\	\	21.84	23.00	\	\	0.099	0.13	0.063	0.08	0.19
Head	LTE Band 66	132572	1770.0	1RB0	Right Cheek	0mm	C2	\	22.24	23.50	\	\	0.276	0.37	0.184	0.25	0.14
Body-Worn	LTE Band 66	132572	1770.0	1RB0	Front	15mm	\	\	22.24	23.50	\	\	0.275	0.37	0.168	0.22	-0.08
Body-Worn	LTE Band 66	132322	1745.0	50RB25	Front	15mm	\	\	21.84	23.00	\	\	0.248	0.32	0.152	0.20	0.02
Body-Worn	LTE Band 66	132572	1770.0	1RB0	Rear	15mm	\	\	22.24	23.50	\	\	0.619	0.83	0.355	0.47	0.18
Body-Worn	LTE Band 66	132322	1745.0	50RB25	Rear	15mm	\	\	21.84	23.00	\	\	0.536	0.70	0.295	0.39	-0.11
Body-Worn	LTE Band 66	132322	1745.0	1RB0	Rear	15mm	\	\	22.23	23.50	\	\	0.617	0.83	0.346	0.46	0.01
Body-Worn	LTE Band 66	132072	1720.0	1RB0	Rear	15mm	\	22	22.22	23.50	\	\	0.712	0.96	0.406	0.55	-0.06
Body-Worn	LTE Band 66	132572	1770.0	100RB0	Rear	15mm	\	\	21.89	23.00	\	\	0.524	0.68	0.292	0.38	0.07
Body-Worn	LTE Band 66	132072	1720.0	1RB0	Rear	15mm	C2	\	22.22	23.50	\	\	0.649	0.87	0.374	0.50	0.12

Note: SAR for LTE Band 4 is covered by LTE Band 66 due to similar frequency range, same maximum tune-up limit and same channel bandwidth.



Table 12.12: Bluetooth SAR Values

RF Exposure Conditions	Frequency Band	Channel Number	Frequency (MHz)	Mode/RB	Test Position	Distance	Note	Figure No.	EUT Measured Power (dBm)	Tune up (dBm)	Duty Cycle %	Duty Cycle Scaling Factor	Measured SAR 1g (W/kg)	Calculated SAR 1g (W/kg)	Measured SAR 10g (W/kg)	Calculated SAR 10g (W/kg)	Power Drift
Head	Bluetooth	78	2480.0	8DPSK	Left Cheek	0mm	\	\	6.12	7.50	77.16	1.30	0.048	0.09	0.025	0.04	0.16
Head	Bluetooth	78	2480.0	8DPSK	Left Tilt	0mm	\	\	6.12	7.50	77.16	1.30	<0.01	<0.01	<0.01	<0.01	\
Head	Bluetooth	78	2480.0	8DPSK	Right Cheek	0mm	\	\	6.12	7.50	77.16	1.30	<0.01	<0.01	<0.01	<0.01	\
Head	Bluetooth	78	2480.0	8DPSK	Right Tilt	0mm	\	\	6.12	7.50	77.16	1.30	<0.01	<0.01	<0.01	<0.01	\
Head	Bluetooth	78	2480.0	8DPSK	Left Cheek	0mm	C2	23	6.12	7.50	77.16	1.30	0.050	0.09	0.026	0.05	0.09
Body-Worn	Bluetooth	78	2480.0	8DPSK	Front	15mm	\	24	6.12	7.50	77.16	1.30	0.006	0.01	0.003	0.01	-0.06
Body-Worn	Bluetooth	78	2480.0	8DPSK	Rear	15mm	\	\	6.12	7.50	77.16	1.30	<0.01	<0.01	<0.01	<0.01	\
Body-Worn	Bluetooth	78	2480.0	8DPSK	Front	15mm	C2	\	6.12	7.50	77.16	1.30	0.005	0.01	0.002	0.00	0.09

13. SAR Measurement Variability

SAR measurement variability must be assessed for each frequency band, which is determined by the SAR probe calibration point and tissue-equivalent medium used for the device measurements. When both head and body tissue-equivalent media are required for SAR measurements in a frequency band, the variability measurement procedures should be applied to the tissue medium with the highest measured SAR, using the highest measured SAR configuration for that tissue-equivalent medium.

The following procedures are applied to determine if repeated measurements are required.

- 1) Repeated measurement is not required when the original highest measured SAR is < 0.80 W/kg; steps 2) through 4) do not apply.
- 2) When the original highest measured SAR is ≥ 0.80 W/kg, repeat that measurement once.
- 3) Perform a second repeated measurement only if the ratio of largest to smallest SAR for the original and first repeated measurements is > 1.20 or when the original or repeated measurement is ≥ 1.45 W/kg (~ 10% from the 1-g SAR limit).
- 4) Perform a third repeated measurement only if the original, first or second repeated measurement is ≥ 1.5 W/kg and the ratio of largest to smallest SAR for the original, first and second repeated measurements is > 1.20 .

Table 13.1: SAR Measurement Variability

RF Exposure Conditions	Frequency Band	Frequency		Mode/RB	Test Position	Distance	Original	1 st Repeated	Ratio	2 nd Repeated
		Ch.	MHz				SAR (W/kg)	SAR (W/kg)		SAR (W/kg)
Body-Worn	WCDMA Band 5	4233	846.6	RMC	Rear	15mm	0.927	0.896	1.03	/
Head	LTE Band 5	20600	844.0	1RB49	Left Cheek	0mm	1.130	1.060	1.07	/
Body-Worn	LTE Band 5	20525	836.5	1RB49	Rear	15mm	0.831	0.814	1.02	/

14. Measurement Uncertainty

14.1. Measurement Uncertainty for Normal SAR Tests (300MHz~3GHz)

No.	Error Description	Type	Uncertainty value	Probably Distribution	Div.	(Ci) 1g	(Ci) 10g	Std. Unc. (1g)	Std. Unc. (10g)	Degree of freedom
Measurement system										
1	Probe calibration	B	12.7	N	2	1	1	6.35	6.35	∞
2	Axial isotropy	B	4.7	R	√3	√0.5	√0.5	4.3	4.3	∞
3	Hemispherical isotropy	B	9.6	R	√3	1	1	4.8	4.8	∞
4	Boundary effect	B	1.1	R	√3	1	1	0.6	0.6	∞
5	Linearity	B	4.7	R	√3	1	1	2.7	2.7	∞
6	Detection limit	B	1.0	R	√3	1	1	0.6	0.6	∞
7	Modulation response	B	4.0	R	√3	1	1	2.3	2.3	∞
8	Readout electronics	B	1.0	N	1	1	1	1.0	1.0	∞
9	Response time	B	0.8	R	√3	1	1	0.5	0.5	∞
10	Integration time	B	1.7	R	√3	1	1	1.0	1.0	∞
11	RF ambient conditions-noise	B	3.0	R	√3	1	1	1.7	1.7	∞
12	RF ambient conditions-reflection	B	3.0	R	√3	1	1	1.7	1.7	∞
13	Probe positioned mech. restrictions	B	0.35	R	√3	1	1	0.2	0.2	∞
14	Probe positioning with respect to phantom shell	B	2.9	R	√3	1	1	1.7	1.7	∞
15	Post-processing	B	1.0	R	√3	1	1	0.6	0.6	∞
Test sample related										
16	Test sample positioning	A	3.3	N	1	1	1	3.3	3.3	5
17	Device holder uncertainty	A	3.4	N	1	1	1	3.4	3.4	5
18	Power scaling	B	0	R	√3	1	1	0	0	∞
19	Drift of output power	B	5.0	R	√3	1	1	2.9	2.9	∞
Phantom and set-up										
20	Phantom uncertainty	B	1.0	R	√3	1	1	0.6	0.6	∞
21	Algorithm for correcting SAR for deviations in permittivity and conductivity	B	1.9	N	1	1	0.84	1.9	1.6	∞
22	Liquid conductivity (target)	B	5.0	R	√3	0.64	0.43	1.8	1.2	∞
23	Liquid conductivity (meas.)	A	1.3	N	1	0.64	0.43	0.83	0.56	9
24	Liquid permittivity (target)	B	5.0	R	√3	0.6	0.49	1.7	1.4	∞
25	Liquid permittivity (meas.)	A	1.6	N	1	0.6	0.49	0.96	0.78	9
Combined standard uncertainty		$u_c = \sqrt{\sum_{i=1}^{23} c_i^2 u_i^2}$						11.6	11.4	95.5
Expanded uncertainty (Confidence interval of 95 %)		$u_e = 2u_c$						23.2	22.8	

14.2. Measurement Uncertainty for Normal SAR Tests (3GHz~6GHz)

No.	Error Description	Type	Uncertainty value	Probably Distribution	Div.	(Ci) 1g	(Ci) 10g	Std. Unc. (1g)	Std. Unc. (10g)	Degree of freedom
Measurement system										
1	Probe calibration	B	13.9	N	2	1	1	6.95	6.95	∞
2	Axial isotropy	B	4.7	R	√3	√0.5	√0.5	4.3	4.3	∞
3	Hemispherical isotropy	B	9.6	R	√3	1	1	4.8	4.8	∞
4	Boundary effect	B	1.1	R	√3	1	1	0.6	0.6	∞
5	Linearity	B	4.7	R	√3	1	1	2.7	2.7	∞
6	Detection limit	B	1.0	R	√3	1	1	0.6	0.6	∞
7	modulation response	B	4.0	R	√3	1	1	2.3	2.3	∞
8	Readout electronics	B	1.0	N	1	1	1	1.0	1.0	∞
9	Response time	B	0.0	R	√3	1	1	0.0	0.0	∞
10	Integration time	B	1.7	R	√3	1	1	1.0	1.0	∞
11	RF ambient conditions-noise	B	3.0	R	√3	1	1	1.7	1.7	∞
12	RF ambient conditions-reflection	B	3.0	R	√3	1	1	1.7	1.7	∞
13	Probe positioned mech. Restrictions	B	0.35	R	√3	1	1	0.2	0.2	∞
14	Probe positioning with respect to phantom shell	B	2.9	R	√3	1	1	1.7	1.7	∞
15	Post-processing	B	1.0	R	√3	1	1	0.6	0.6	∞
Test sample related										
16	Test sample positioning	A	3.3	N	1	1	1	3.3	3.3	5
17	Device holder uncertainty	A	3.4	N	1	1	1	3.4	3.4	5
18	Power scaling	B	0	R	√3	1	1	0	0	∞
19	Drift of output power	B	5.0	R	√3	1	1	2.9	2.9	∞
Phantom and set-up										
20	Phantom uncertainty	B	1.0	R	√3	1	1	0.6	0.6	∞
21	Algorithm for correcting SAR for deviations in permittivity and conductivity	B	1.9	N	1	1	0.84	1.9	1.6	∞
22	Liquid conductivity (target)	B	5.0	R	√3	0.64	0.43	1.8	1.2	∞
23	Liquid conductivity (meas.)	A	1.3	N	1	0.64	0.43	0.83	0.56	9
24	Liquid permittivity (target)	B	5.0	R	√3	0.6	0.49	1.7	1.4	∞
25	Liquid permittivity (meas.)	A	1.6	N	1	0.6	0.49	0.96	0.78	9
Combined standard uncertainty		$u_c = \sqrt{\sum_{i=1}^{22} c_i^2 u_i^2}$						11.9	11.8	95.5
Expanded uncertainty (Confidence interval of 95 %)		$u_e = 2u_c$						23.8	23.6	

15. Main Test Instruments

Table 15.1: List of Main Instruments

No.	Name	Type	Serial Number	Calibration Date	Valid Period
01	Network analyzer	E5071C	MY46103759	2023-11-13	One year
02	Dielectric probe	85070E	MY44300317	/	/
03	Power meter	E4418B	MY50000366	2023-12-10	One year
04	Power sensor	E9304A	MY50000188	2023-12-10	One year
05	Power meter	NRP	102603	2023-12-28	One year
06	Power sensor	NRP-Z51	102211	2023-12-28	One year
07	Signal Generator	E8257D	MY47461211	2024-01-12	One year
08	Amplifier	VTL5400	0404	/	/
09	DAE	DAE4	786	2023-12-11	One year
10	E-field Probe	EX3DV4	7621	2024-01-10	One year
11	Dipole Validation Kit	D750V3	1163	2022-08-22	Three years
12	Dipole Validation Kit	D835V2	4d057	2021-10-18	Three years
13	Dipole Validation Kit	D1750V2	1152	2022-08-22	Three years
14	Dipole Validation Kit	D1900V2	5d088	2021-10-18	Three years
15	Dipole Validation Kit	D2450V2	873	2021-10-21	Three years
16	Dipole Validation Kit	D2550V2	1010	2024-04-23	Three years
17	BTS	E5515C	GB46110722	2024-01-12	One year
18	BTS	MT8820C	6201341853	2024-03-22	One year
19	Thermometer	51II	99250045	2023-11-22	One year
20	Software	DASY5 & DASY8	/	/	/



ANNEX A: Graph Results

GSM 850 Head

Exposure Conditions

Phantom Section, TSL	Position, Test Distance [mm]	Band	Group, UID	Frequency [MHz], Channel Number	Conversion Factor	TSL Conductivity [S/m]	TSL Permittivity
Right Head, HSL	CHEEK, 0.00	GSM 850	GSM, 10021-DAC	824.2, 128	11.02	0.90	40.8

Hardware Setup

Phantom	TSL, Measured Date	Probe, Calibration Date	DAE, Calibration Date
Twin-SAM V8.0 (30deg probe tilt) - 2130	835MHz-Head Charge:2024-07-05	EX3DV4 - SN7621, 2024-01-10	DAE4 Sn786, 2023-12-11

Scans Setup

	Area Scan	Zoom Scan
Grid Extents [mm]	90.0 x 120.0	32.0 x 32.0 x 30.0
Grid Steps [mm]	15.0 x 15.0	8.0 x 8.0 x 5.0
Sensor Surface [mm]	3.0	1.4
Graded Grid	n/a	Yes
Grading Ratio	n/a	1.5
MAIA	N/A	N/A
Surface Detection	VMS + 6p	VMS + 6p
Scan Method	Measured	Measured

Measurement Results

	Area Scan	Zoom Scan
Date	2024-07-05	2024-07-05
psSAR1g [W/Kg]	0.648	0.713
psSAR10g [W/Kg]	0.477	0.528
Power Drift [dB]	0.01	0.06
Power Scaling	Disabled	Disabled
Scaling Factor [dB]		
TSL Correction	No correction	No correction
M2/M1 [%]		76.2
Dist 3dB Peak [mm]		> 16.0

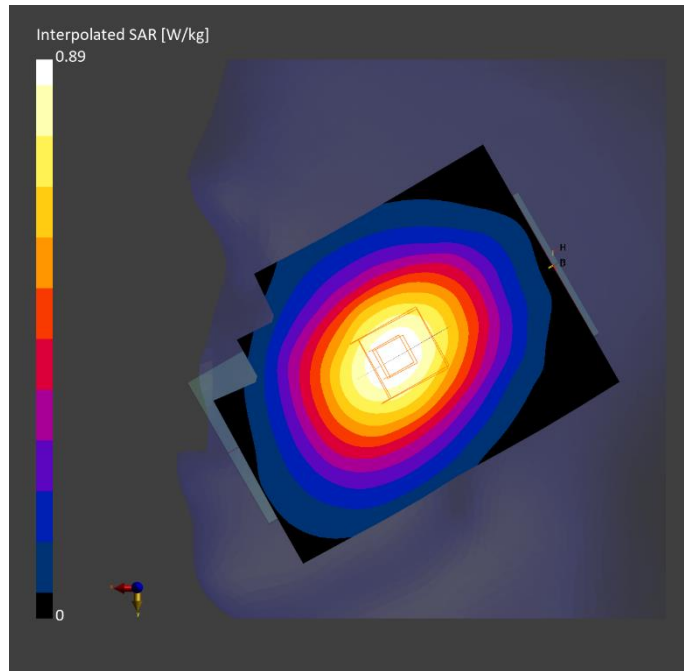

Fig.1 GSM 850 Head



GSM 850 Body

Exposure Conditions

Phantom Section, TSL	Position, Test Distance [mm]	Band	Group, UID	Frequency [MHz], Channel Number	Conversion Factor	TSL Conductivity [S/m]	TSL Permittivity
Flat, HSL	BACK, 15.00	GSM 850	GSM, 10024-DAC	824.2, 128	11.02	0.90	40.8

Hardware Setup

Phantom	TSL, Measured Date	Probe, Calibration Date	DAE, Calibration Date
Twin-SAM V8.0 (30deg probe tilt) - 2130	835MHz-Head Charge:2024-07-05	EX3DV4 - SN7621, 2024-01-10	DAE4 Sn786, 2023-12-11

Scans Setup

	Area Scan	Zoom Scan
Grid Extents [mm]	90.0 x 120.0	32.0 x 32.0 x 30.0
Grid Steps [mm]	15.0 x 15.0	8.0 x 8.0 x 5.0
Sensor Surface [mm]	3.0	1.4
Graded Grid	n/a	Yes
Grading Ratio	n/a	1.5
MAIA	N/A	N/A
Surface Detection	All points	All points
Scan Method	Measured	Measured

Measurement Results

	Area Scan	Zoom Scan
Date	2024-07-05	2024-07-05
psSAR1g [W/Kg]	0.698	0.740
psSAR10g [W/Kg]	0.483	0.529
Power Drift [dB]	-0.03	0.08
Power Scaling	Disabled	Disabled
Scaling Factor [dB]		
TSL Correction	No correction	No correction
M2/M1 [%]		69.6
Dist 3dB Peak [mm]		> 16.0

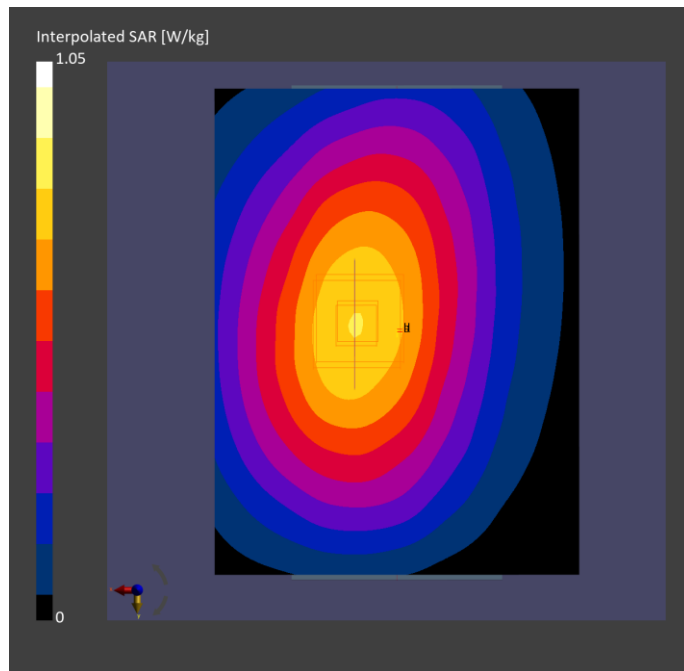

Fig.2 GSM 850 Body



GSM 1900 Head

Exposure Conditions

Phantom Section, TSL	Position, Test Distance [mm]	Band	Group, UID	Frequency [MHz], Channel Number	Conversion Factor	TSL Conductivity [S/m]	TSL Permittivity
Right Head, HSL	CHEEK, 0.00	PCS 1900	GSM, 10021-DAC	1850.2, 512	8.76	1.38	39.4

Hardware Setup

Phantom	TSL, Measured Date	Probe, Calibration Date	DAE, Calibration Date
Twin-SAM V8.0 (30deg probe tilt) - 2130	1900MHz-Head Charge:2024-07-07	EX3DV4 - SN7621, 2024-01-10	DAE4 Sn786, 2023-12-11

Scans Setup

	Area Scan	Zoom Scan
Grid Extents [mm]	90.0 x 90.0	32.0 x 32.0 x 30.0
Grid Steps [mm]	15.0 x 15.0	8.0 x 8.0 x 5.0
Sensor Surface [mm]	3.0	1.4
Graded Grid	n/a	Yes
Grading Ratio	n/a	1.5
MAIA	N/A	N/A
Surface Detection	VMS + 6p	All points
Scan Method	Measured	Measured

Measurement Results

	Area Scan	Zoom Scan
Date	2024-07-07	2024-07-07
psSAR1g [W/Kg]	0.198	0.202
psSAR10g [W/Kg]	0.118	0.136
Power Drift [dB]	0.03	0.02
Power Scaling	Disabled	Disabled
Scaling Factor [dB]		
TSL Correction	No correction	No correction
M2/M1 [%]		69.9
Dist 3dB Peak [mm]		16.6

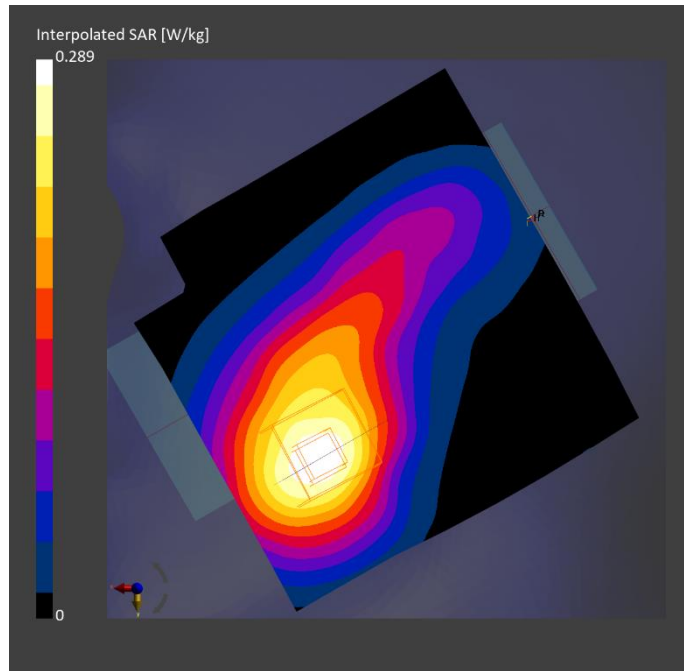

Fig.3 GSM 1900 Head



GSM 1900 Body

Exposure Conditions

Phantom Section, TSL	Position, Test Distance [mm]	Band	Group, UID	Frequency [MHz], Channel Number	Conversion Factor	TSL Conductivity [S/m]	TSL Permittivity
Flat, HSL	BACK, 15.00	PCS 1900	GSM, 10027-DAC	1850.2, 512	8.76	1.38	39.4

Hardware Setup

Phantom	TSL, Measured Date	Probe, Calibration Date	DAE, Calibration Date
Twin-SAM V8.0 (30deg probe tilt) - 2130	1900MHz-Head Charge:2024-07-07	EX3DV4 - SN7621, 2024-01-10	DAE4 Sn786, 2023-12-11

Scans Setup

	Area Scan	Zoom Scan
Grid Extents [mm]	90.0 x 90.0	32.0 x 32.0 x 30.0
Grid Steps [mm]	15.0 x 15.0	8.0 x 8.0 x 5.0
Sensor Surface [mm]	3.0	1.4
Graded Grid	n/a	Yes
Grading Ratio	n/a	1.5
MAIA	N/A	N/A
Surface Detection	All points	All points
Scan Method	Measured	Measured

Measurement Results

	Area Scan	Zoom Scan
Date	2024-07-07	2024-07-07
psSAR1g [W/Kg]	0.392	0.402
psSAR10g [W/Kg]	0.221	0.228
Power Drift [dB]	-0.02	0.01
Power Scaling	Disabled	Disabled
Scaling Factor [dB]		
TSL Correction	No correction	No correction
M2/M1 [%]		57.2
Dist 3dB Peak [mm]		14.5

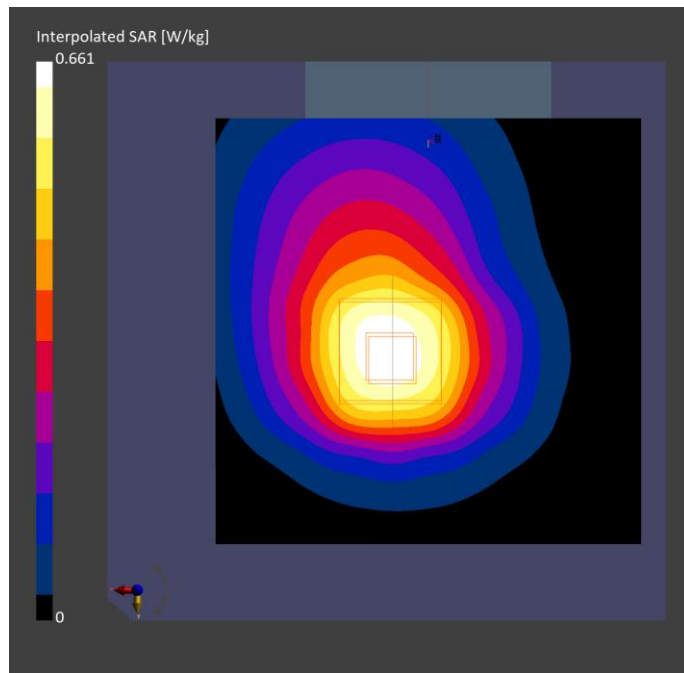

Fig.4 GSM 1900 Body



WCDMA Band 2 Head

Exposure Conditions

Phantom Section, TSL	Position, Test Distance [mm]	Band	Group, UID	Frequency [MHz], Channel Number	Conversion Factor	TSL Conductivity [S/m]	TSL Permittivity
Right Head, HSL	CHEEK, 0.00	Band 2	WCDMA, 10011-CAC	1880.0, 9400	8.76	1.41	39.3

Hardware Setup

Phantom	TSL, Measured Date	Probe, Calibration Date	DAE, Calibration Date
Twin-SAM V8.0 (30deg probe tilt) - 2130	1900MHz-Head Charge:2024-07-07	EX3DV4 - SN7621, 2024-01-10	DAE4 Sn786, 2023-12-11

Scans Setup

	Area Scan	Zoom Scan
Grid Extents [mm]	90.0 x 90.0	32.0 x 32.0 x 30.0
Grid Steps [mm]	15.0 x 15.0	8.0 x 8.0 x 5.0
Sensor Surface [mm]	3.0	1.4
Graded Grid	n/a	Yes
Grading Ratio	n/a	1.5
MAIA	N/A	N/A
Surface Detection	Unknown method	All points
Scan Method	Measured	Measured

Measurement Results

	Area Scan	Zoom Scan
Date	2024-07-07	2024-07-07
psSAR1g [W/Kg]	0.387	0.409
psSAR10g [W/Kg]	0.231	0.268
Power Drift [dB]	0.09	0.01
Power Scaling	Disabled	Disabled
Scaling Factor [dB]		
TSL Correction	No correction	No correction
M2/M1 [%]		69.8
Dist 3dB Peak [mm]		17.0

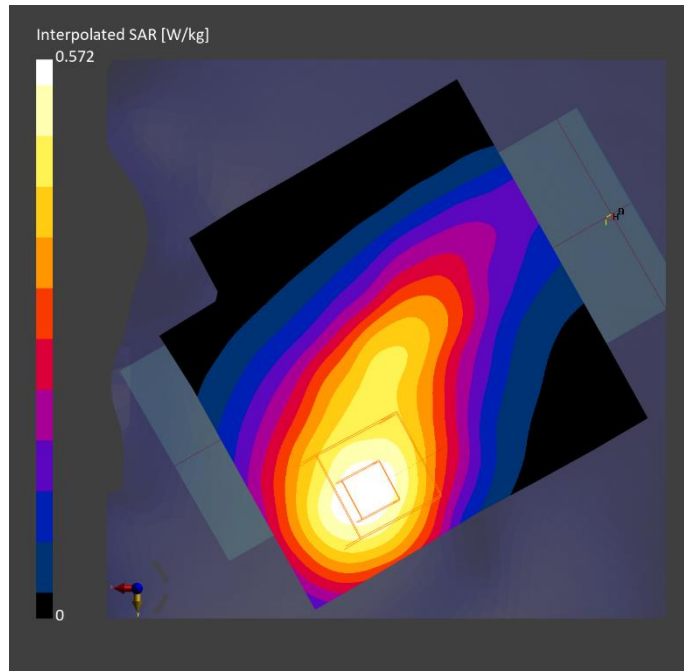

Fig.5 WCDMA Band 2 Head



WCDMA Band 2 Body

Exposure Conditions

Phantom Section, TSL	Position, Test Distance [mm]	Band	Group, UID	Frequency [MHz], Channel Number	Conversion Factor	TSL Conductivity [S/m]	TSL Permittivity
Flat, HSL	BACK, 15.00	Band 2	WCDMA, 10011-CAC	1880.0, 9400	8.76	1.41	39.3

Hardware Setup

Phantom	TSL, Measured Date	Probe, Calibration Date	DAE, Calibration Date
Twin-SAM V8.0 (30deg probe tilt) - 2130	1900MHz-Head Charge:2024-07-07	EX3DV4 - SN7621, 2024-01-10	DAE4 Sn786, 2023-12-11

Scans Setup

	Area Scan	Zoom Scan
Grid Extents [mm]	90.0 x 120.0	32.0 x 40.0 x 30.0
Grid Steps [mm]	15.0 x 15.0	8.0 x 5.0 x 5.0
Sensor Surface [mm]	3.0	1.4
Graded Grid	n/a	Yes
Grading Ratio	n/a	1.5
MAIA	N/A	N/A
Surface Detection	All points	All points
Scan Method	Measured	Measured

Measurement Results

	Area Scan	Zoom Scan
Date	2024-07-07	2024-07-07
psSAR1g [W/Kg]	0.584	0.645
psSAR10g [W/Kg]	0.340	0.365
Power Drift [dB]	0.08	0.03
Power Scaling	Disabled	Disabled
Scaling Factor [dB]		
TSL Correction	No correction	No correction
M2/M1 [%]		57.0
Dist 3dB Peak [mm]		13.1

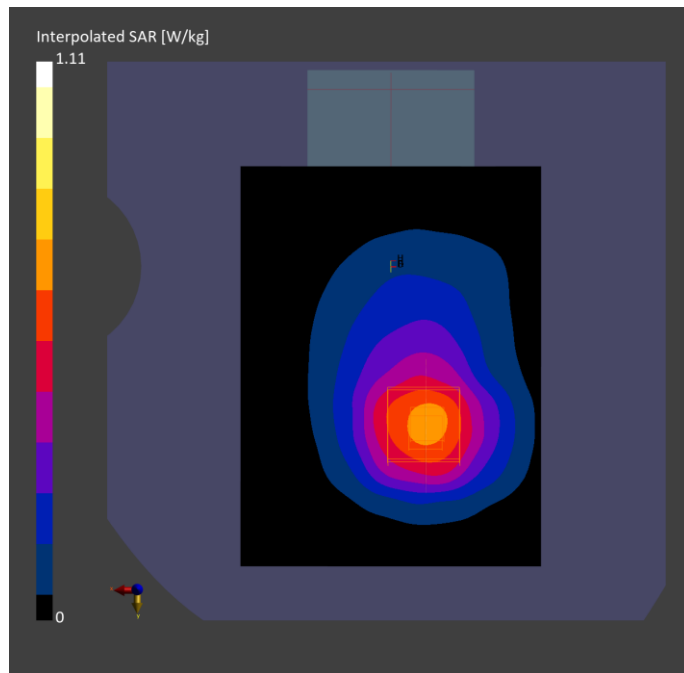

Fig.6 WCDMA Band 2 Body



WCDMA Band 4 Head

Exposure Conditions

Phantom Section, TSL	Position, Test Distance [mm]	Band	Group, UID	Frequency [MHz], Channel Number	Conversion Factor	TSL Conductivity [S/m]	TSL Permittivity
Right Head, HSL	CHEEK, 0.00	Band 4	WCDMA, 10011-CAC	1732.6, 1413	9.11	1.37	39.5

Hardware Setup

Phantom	TSL, Measured Date	Probe, Calibration Date	DAE, Calibration Date
Twin-SAM V8.0 (30deg probe tilt) - 2130	1750MHz-Head Charge:2024-06-21	EX3DV4 - SN7621, 2024-01-10	DAE4 Sn786, 2023-12-11

Scans Setup

	Area Scan	Zoom Scan
Grid Extents [mm]	90.0 x 90.0	32.0 x 32.0 x 30.0
Grid Steps [mm]	15.0 x 15.0	8.0 x 8.0 x 5.0
Sensor Surface [mm]	3.0	1.4
Graded Grid	n/a	Yes
Grading Ratio	n/a	1.5
MAIA	N/A	N/A
Surface Detection	VMS + 6p	All points
Scan Method	Measured	Measured

Measurement Results

	Area Scan	Zoom Scan
Date	2024-06-21	2024-06-21
psSAR1g [W/Kg]	0.348	0.361
psSAR10g [W/Kg]	0.212	0.242
Power Drift [dB]	0.07	0.02
Power Scaling	Disabled	Disabled
Scaling Factor [dB]		
TSL Correction	No correction	No correction
M2/M1 [%]		68.9
Dist 3dB Peak [mm]		16.6

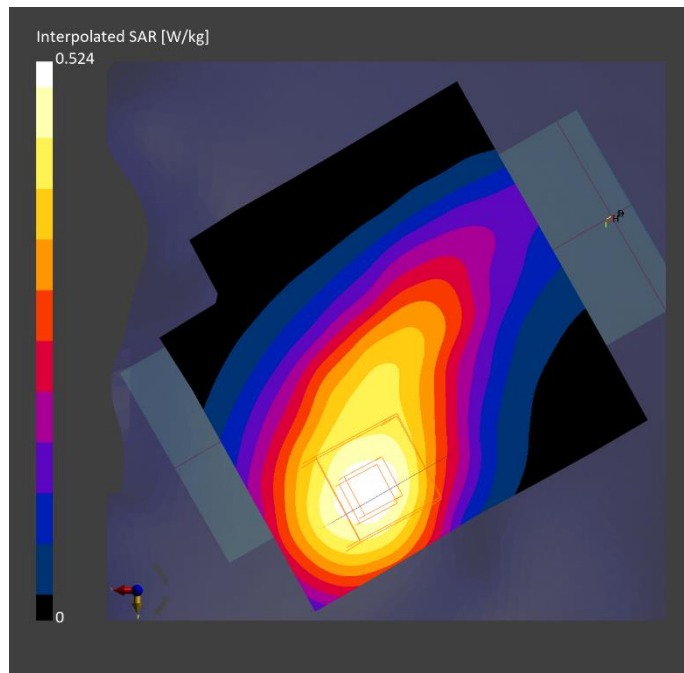

Fig.7 WCDMA Band 4 Head



WCDMA Band 4 Body

Exposure Conditions

Phantom Section, TSL	Position, Test Distance [mm]	Band	Group, UID	Frequency [MHz], Channel Number	Conversion Factor	TSL Conductivity [S/m]	TSL Permittivity
Flat, HSL	BACK, 15.00	Band 4	WCDMA, 10011-CAC	1712.4, 1312	9.11	1.36	39.6

Hardware Setup

Phantom	TSL, Measured Date	Probe, Calibration Date	DAE, Calibration Date
Twin-SAM V8.0 (30deg probe tilt) - 2130	1750MHz-Head Charge:2024-06-21	EX3DV4 - SN7621, 2024-01-10	DAE4 Sn786, 2023-12-11

Scans Setup

	Area Scan	Zoom Scan
Grid Extents [mm]	90.0 x 120.0	32.0 x 32.0 x 30.0
Grid Steps [mm]	15.0 x 15.0	8.0 x 8.0 x 5.0
Sensor Surface [mm]	3.0	1.4
Graded Grid	n/a	Yes
Grading Ratio	n/a	1.5
MAIA	N/A	N/A
Surface Detection	All points	All points
Scan Method	Measured	Measured

Measurement Results

	Area Scan	Zoom Scan
Date	2024-06-21	2024-06-21
psSAR1g [W/Kg]	0.734	0.784
psSAR10g [W/Kg]	0.423	0.451
Power Drift [dB]	0.07	-0.12
Power Scaling	Disabled	Disabled
Scaling Factor [dB]		
TSL Correction	No correction	No correction
M2/M1 [%]		58.2
Dist 3dB Peak [mm]		14.4

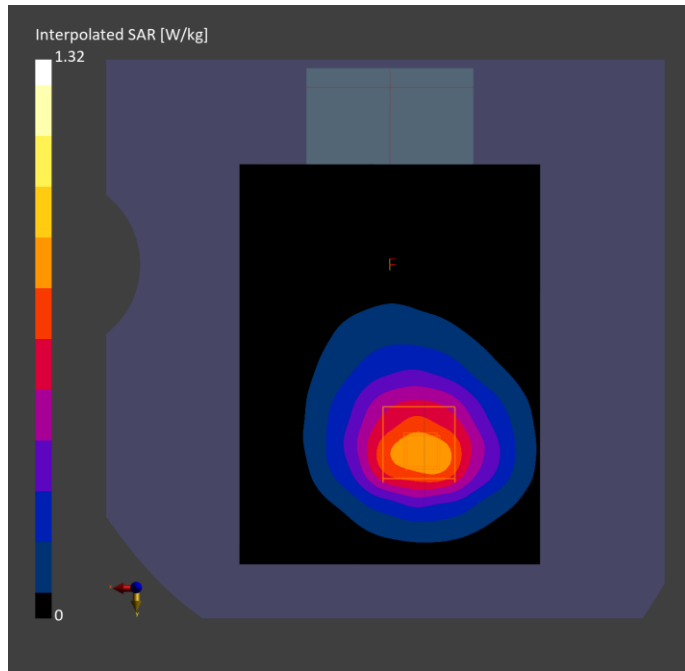

Fig.8 WCDMA Band 4 Body



WCDMA Band 5 Head

Exposure Conditions

Phantom Section, TSL	Position, Test Distance [mm]	Band	Group, UID	Frequency [MHz], Channel Number	Conversion Factor	TSL Conductivity [S/m]	TSL Permittivity
Left Head, HSL	CHEEK, 0.00	Band 5	WCDMA, 10011-CAC	836.6, 4183	11.02	0.91	40.6

Hardware Setup

Phantom	TSL, Measured Date	Probe, Calibration Date	DAE, Calibration Date
Twin-SAM V8.0 (30deg probe tilt) - 2130	835MHz-Head Charge:2024-07-05	EX3DV4 - SN7621, 2024-01-10	DAE4 Sn786, 2023-12-11

Scans Setup

	Area Scan	Zoom Scan
Grid Extents [mm]	90.0 x 90.0	32.0 x 32.0 x 30.0
Grid Steps [mm]	15.0 x 15.0	8.0 x 8.0 x 5.0
Sensor Surface [mm]	3.0	1.4
Graded Grid	n/a	Yes
Grading Ratio	n/a	1.5
MAIA	N/A	N/A
Surface Detection	VMS + 6p	All points
Scan Method	Measured	Measured

Measurement Results

	Area Scan	Zoom Scan
Date	2024-07-05	2024-07-05
psSAR1g [W/Kg]	0.748	0.785
psSAR10g [W/Kg]	0.512	0.578
Power Drift [dB]	-0.05	-0.08
Power Scaling	Disabled	Disabled
Scaling Factor [dB]		
TSL Correction	No correction	No correction
M2/M1 [%]		68.9
Dist 3dB Peak [mm]		16.6

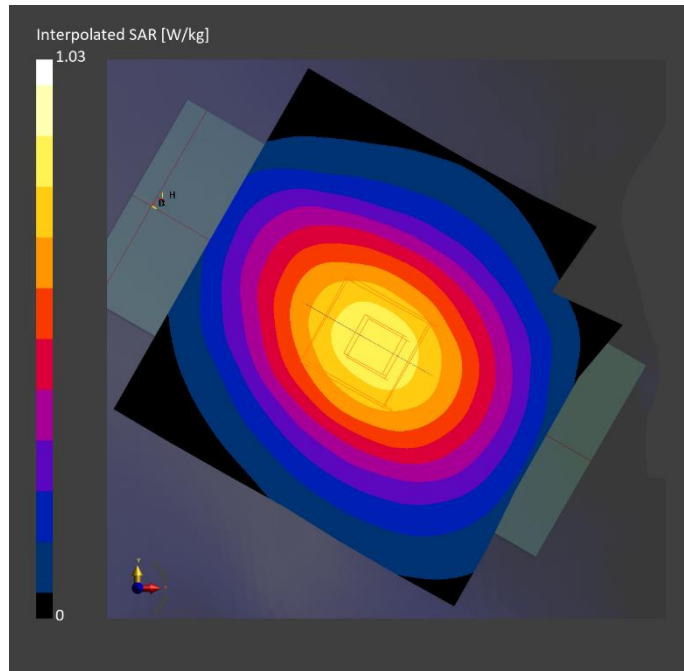

Fig.9 WCDMA Band 5 Head



WCDMA Band 5 Body

Exposure Conditions

Phantom Section, TSL	Position, Test Distance [mm]	Band	Group, UID	Frequency [MHz], Channel Number	Conversion Factor	TSL Conductivity [S/m]	TSL Permittivity
Flat, HSL	BACK, 15.00	Band 5	WCDMA, 10011-CAC	846.6, 4233	11.02	0.92	40.5

Hardware Setup

Phantom	TSL, Measured Date	Probe, Calibration Date	DAE, Calibration Date
Twin-SAM V8.0 (30deg probe tilt) - 2130	835MHz-Head Charge:2024-07-05	EX3DV4 - SN7621, 2024-01-10	DAE4 Sn786, 2023-12-11

Scans Setup

	Area Scan	Zoom Scan
Grid Extents [mm]	90.0 x 90.0	32.0 x 32.0 x 30.0
Grid Steps [mm]	15.0 x 15.0	8.0 x 8.0 x 5.0
Sensor Surface [mm]	3.0	1.4
Graded Grid	n/a	Yes
Grading Ratio	n/a	1.5
MAIA	N/A	N/A
Surface Detection	All points	All points
Scan Method	Measured	Measured

Measurement Results

	Area Scan	Zoom Scan
Date	2024-07-05	2024-07-05
psSAR1g [W/Kg]	0.852	0.927
psSAR10g [W/Kg]	0.618	0.678
Power Drift [dB]	-0.02	0.10
Power Scaling	Disabled	Disabled
Scaling Factor [dB]		
TSL Correction	No correction	No correction
M2/M1 [%]		71.1
Dist 3dB Peak [mm]		> 16.0

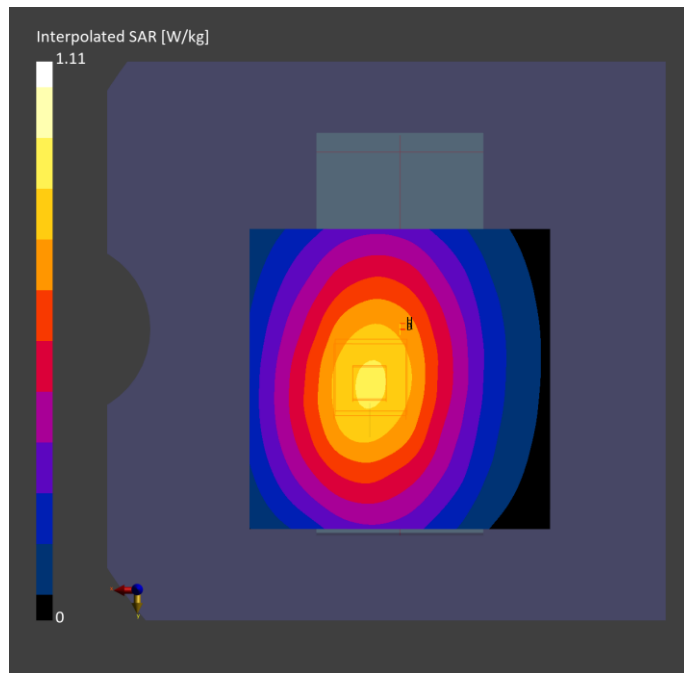

Fig.10 WCDMA Band 5 Body



LTE Band 2 Head

Exposure Conditions

Phantom Section, TSL	Position, Test Distance [mm]	Band	Group, UID	Frequency [MHz], Channel Number	Conversion Factor	TSL Conductivity [S/m]	TSL Permittivity
Right Head, HSL	CHEEK, 0.00	Band 2	LTE-FDD, 10169-CAF	1900.0, 19100	8.76	1.43	39.2

Hardware Setup

Phantom	TSL, Measured Date	Probe, Calibration Date	DAE, Calibration Date
Twin-SAM V8.0 (30deg probe tilt) - 2130	1900MHz-Head Charge:2024-07-07	EX3DV4 - SN7621, 2024-01-10	DAE4 Sn786, 2023-12-11

Scans Setup

	Area Scan	Zoom Scan
Grid Extents [mm]	90.0 x 90.0	32.0 x 32.0 x 30.0
Grid Steps [mm]	15.0 x 15.0	8.0 x 8.0 x 5.0
Sensor Surface [mm]	3.0	1.4
Graded Grid	n/a	Yes
Grading Ratio	n/a	1.5
MAIA	N/A	N/A
Surface Detection	VMS + 6p	All points
Scan Method	Measured	Measured

Measurement Results

	Area Scan	Zoom Scan
Date	2024-07-07	2024-07-07
psSAR1g [W/Kg]	0.440	0.485
psSAR10g [W/Kg]	0.260	0.307
Power Drift [dB]	0.03	0.06
Power Scaling	Disabled	Disabled
Scaling Factor [dB]		
TSL Correction	No correction	No correction
M2/M1 [%]		76.0
Dist 3dB Peak [mm]		6.5

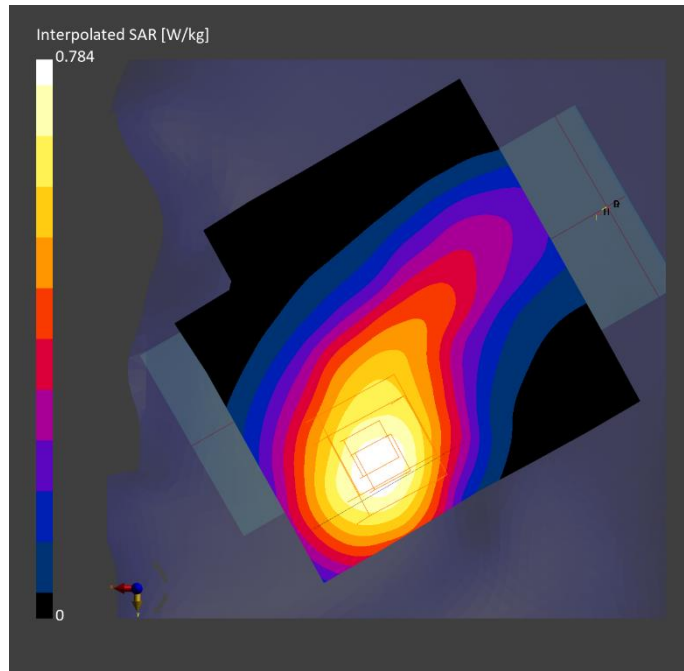

Fig.11 LTE Band 2 Head



LTE Band 2 Body

Exposure Conditions

Phantom Section, TSL	Position, Test Distance [mm]	Band	Group, UID	Frequency [MHz], Channel Number	Conversion Factor	TSL Conductivity [S/m]	TSL Permittivity
Flat, HSL	BACK, 15.00	Band 2	LTE-FDD, 10169-CAF	1900.0, 19100	8.76	1.43	39.2

Hardware Setup

Phantom	TSL, Measured Date	Probe, Calibration Date	DAE, Calibration Date
Twin-SAM V8.0 (30deg probe tilt) - 2130	1900MHz-Head Charge:2024-07-07	EX3DV4 - SN7621, 2024-01-10	DAE4 Sn786, 2023-12-11

Scans Setup

	Area Scan	Zoom Scan
Grid Extents [mm]	90.0 x 90.0	32.0 x 32.0 x 30.0
Grid Steps [mm]	15.0 x 15.0	8.0 x 8.0 x 5.0
Sensor Surface [mm]	3.0	1.4
Graded Grid	n/a	Yes
Grading Ratio	n/a	1.5
MAIA	N/A	N/A
Surface Detection	All points	All points
Scan Method	Measured	Measured

Measurement Results

	Area Scan	Zoom Scan
Date	2024-07-07	2024-07-07
psSAR1g [W/Kg]	0.654	0.685
psSAR10g [W/Kg]	0.372	0.390
Power Drift [dB]	0.02	0.05
Power Scaling	Disabled	Disabled
Scaling Factor [dB]		
TSL Correction	No correction	No correction
M2/M1 [%]		56.5
Dist 3dB Peak [mm]		14.5

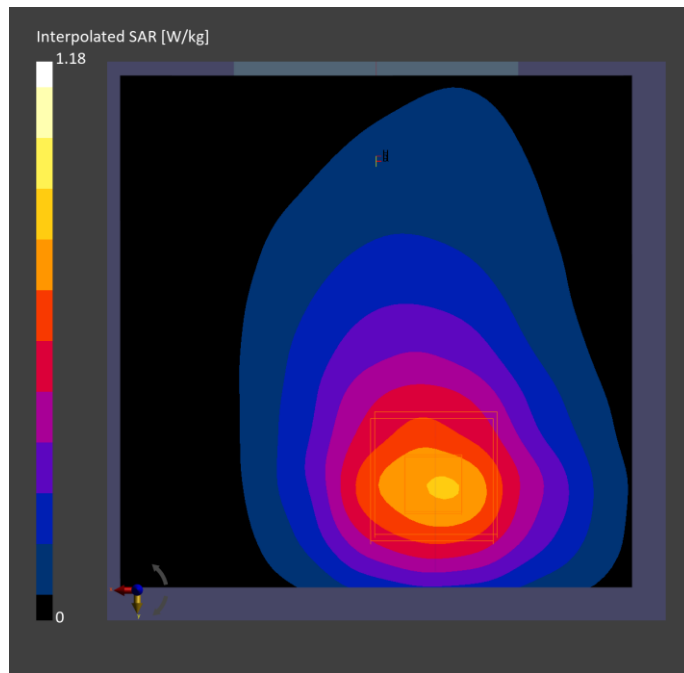

Fig.12 LTE Band 2 Body



LTE Band 5 Head

Exposure Conditions

Phantom Section, TSL	Position, Test Distance [mm]	Band	Group, UID	Frequency [MHz], Channel Number	Conversion Factor	TSL Conductivity [S/m]	TSL Permittivity
Left Head, HSL	CHEEK, 0.00	Band 5	LTE-FDD, 10175-CAH	844.0, 20600	11.02	0.92	40.5

Hardware Setup

Phantom	TSL, Measured Date	Probe, Calibration Date	DAE, Calibration Date
Twin-SAM V8.0 (30deg probe tilt) - 2130	835MHz-Head Charge:2024-07-05	EX3DV4 - SN7621, 2024-01-10	DAE4 Sn786, 2023-12-11

Scans Setup

	Area Scan	Zoom Scan
Grid Extents [mm]	90.0 x 90.0	32.0 x 32.0 x 30.0
Grid Steps [mm]	15.0 x 15.0	8.0 x 8.0 x 5.0
Sensor Surface [mm]	3.0	1.4
Graded Grid	n/a	Yes
Grading Ratio	n/a	1.5
MAIA	N/A	N/A
Surface Detection	VMS + 6p	All points
Scan Method	Measured	Measured

Measurement Results

	Area Scan	Zoom Scan
Date	2024-07-05	2024-07-05
psSAR1g [W/Kg]	1.05	1.13
psSAR10g [W/Kg]	0.710	0.834
Power Drift [dB]	0.02	0.00
Power Scaling	Disabled	Disabled
Scaling Factor [dB]		
TSL Correction	No correction	No correction
M2/M1 [%]		76.7
Dist 3dB Peak [mm]		> 16.0

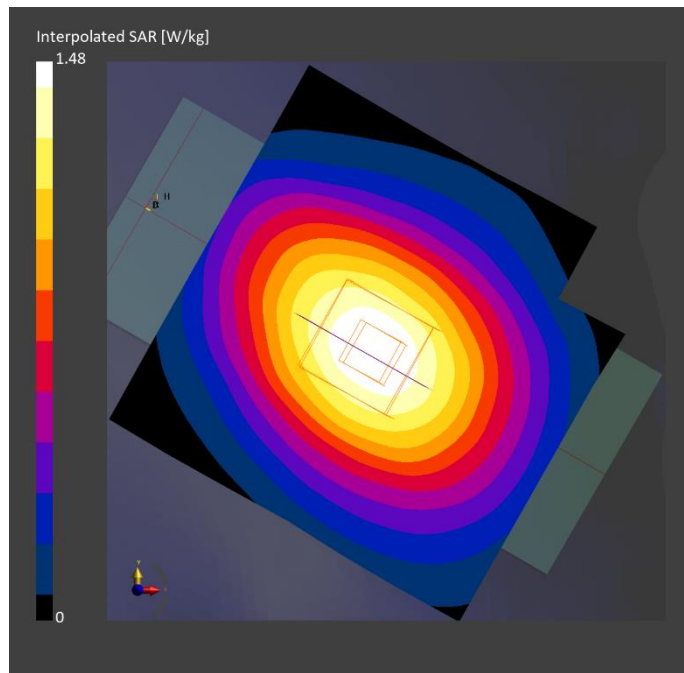

Fig.13 LTE Band 5 Head



LTE Band 5 Body

Exposure Conditions

Phantom Section, TSL	Position, Test Distance [mm]	Band	Group, UID	Frequency [MHz], Channel Number	Conversion Factor	TSL Conductivity [S/m]	TSL Permittivity
Flat, HSL	BACK, 15.00	Band 5	LTE-FDD, 10175-CAH	836.5, 20525	11.02	0.91	40.6

Hardware Setup

Phantom	TSL, Measured Date	Probe, Calibration Date	DAE, Calibration Date
Twin-SAM V8.0 (30deg probe tilt) - 2130	835MHz-Head Charge:2024-07-05	EX3DV4 - SN7621, 2024-01-10	DAE4 Sn786, 2023-12-11

Scans Setup

	Area Scan	Zoom Scan
Grid Extents [mm]	90.0 x 90.0	32.0 x 32.0 x 30.0
Grid Steps [mm]	15.0 x 15.0	8.0 x 8.0 x 5.0
Sensor Surface [mm]	3.0	1.4
Graded Grid	n/a	Yes
Grading Ratio	n/a	1.5
MAIA	N/A	N/A
Surface Detection	All points	All points
Scan Method	Measured	Measured

Measurement Results

	Area Scan	Zoom Scan
Date	2024-07-05	2024-07-05
psSAR1g [W/Kg]	0.791	0.831
psSAR10g [W/Kg]	0.543	0.588
Power Drift [dB]	-0.04	0.06
Power Scaling	Disabled	Disabled
Scaling Factor [dB]		
TSL Correction	No correction	No correction
M2/M1 [%]		70.2
Dist 3dB Peak [mm]		> 16.0

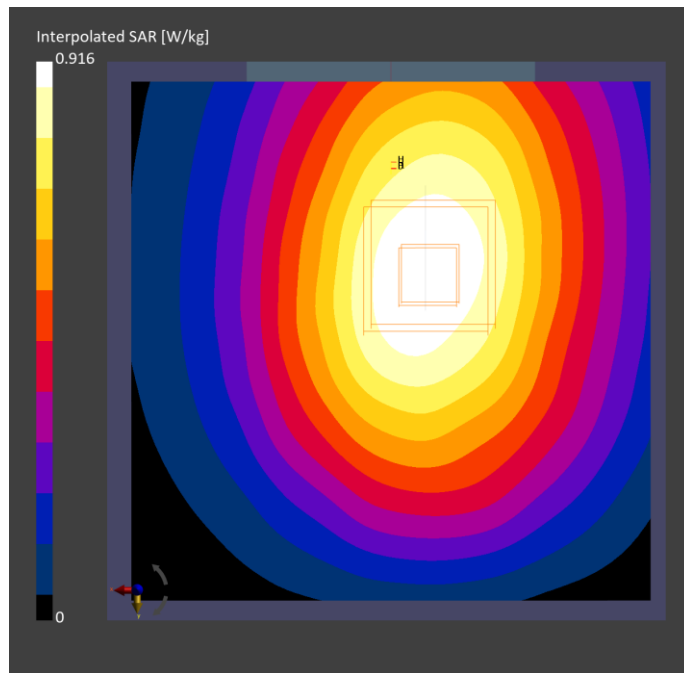

Fig.14 LTE Band 5 Body



LTE Band 7 Head

Exposure Conditions

Phantom Section, TSL	Position, Test Distance [mm]	Band	Group, UID	Frequency [MHz], Channel Number	Conversion Factor	TSL Conductivity [S/m]	TSL Permittivity
Right Head, HSL	CHEEK, 0.00	Band 7	LTE-FDD, 10169-CAF	2560.0, 21350	8.02	1.96	38.1

Hardware Setup

Phantom	TSL, Measured Date	Probe, Calibration Date	DAE, Calibration Date
Twin-SAM V8.0 (30deg probe tilt) - 2130	2550MHz-Head Charge:2024-07-03	EX3DV4 - SN7621, 2024-01-10	DAE4 Sn786, 2023-12-11

Scans Setup

	Area Scan	Zoom Scan
Grid Extents [mm]	90.0 x 120.0	30.0 x 30.0 x 30.0
Grid Steps [mm]	10.0 x 10.0	5.0 x 5.0 x 5.0
Sensor Surface [mm]	3.0	1.4
Graded Grid	n/a	Yes
Grading Ratio	n/a	1.5
MAIA	N/A	N/A
Surface Detection	VMS + 6p	VMS + 6p
Scan Method	Measured	Measured

Measurement Results

	Area Scan	Zoom Scan
Date	2024-07-03	2024-07-03
psSAR1g [W/Kg]	0.768	0.771
psSAR10g [W/Kg]	0.437	0.487
Power Drift [dB]	-0.18	-0.02
Power Scaling	Disabled	Disabled
Scaling Factor [dB]		
TSL Correction	No correction	No correction
M2/M1 [%]		64.1
Dist 3dB Peak [mm]		16.2

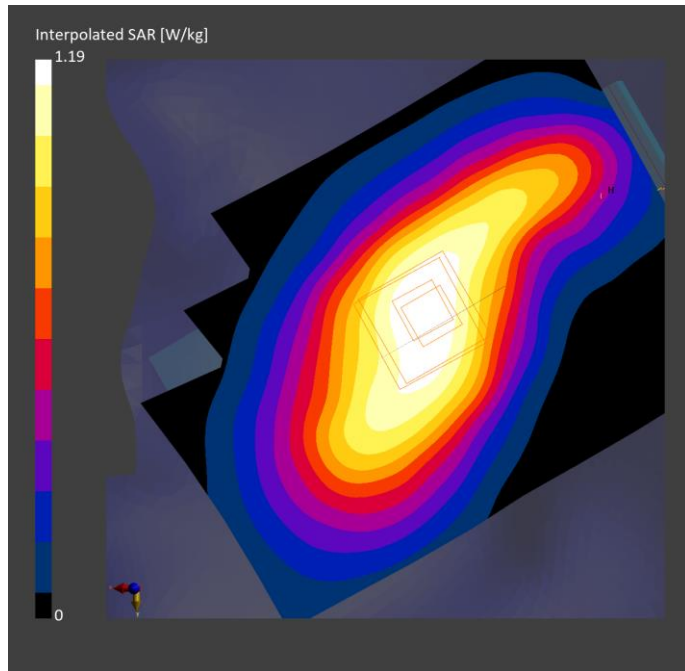

Fig.15 LTE Band 7 Head



LTE Band 7 Body

Exposure Conditions

Phantom Section, TSL	Position, Test Distance [mm]	Band	Group, UID	Frequency [MHz], Channel Number	Conversion Factor	TSL Conductivity [S/m]	TSL Permittivity
Flat, HSL	BACK, 15.00	Band 7	LTE-FDD, 10169-CAF	2560.0, 21350	8.02	1.96	38.1

Hardware Setup

Phantom	TSL, Measured Date	Probe, Calibration Date	DAE, Calibration Date
Twin-SAM V8.0 (30deg probe tilt) - 2130	2550MHz-Head Charge:2024-07-03	EX3DV4 - SN7621, 2024-01-10	DAE4 Sn786, 2023-12-11

Scans Setup

	Area Scan	Zoom Scan
Grid Extents [mm]	90.0 x 90.0	30.0 x 30.0 x 30.0
Grid Steps [mm]	10.0 x 10.0	5.0 x 5.0 x 5.0
Sensor Surface [mm]	3.0	1.4
Graded Grid	n/a	Yes
Grading Ratio	n/a	1.5
MAIA	N/A	N/A
Surface Detection	All points	All points
Scan Method	Measured	Measured

Measurement Results

	Area Scan	Zoom Scan
Date	2024-07-03	2024-07-03
psSAR1g [W/Kg]	0.522	0.505
psSAR10g [W/Kg]	0.296	0.302
Power Drift [dB]	-0.07	-0.07
Power Scaling	Disabled	Disabled
Scaling Factor [dB]		
TSL Correction	No correction	No correction
M2/M1 [%]		55.7
Dist 3dB Peak [mm]		19.4

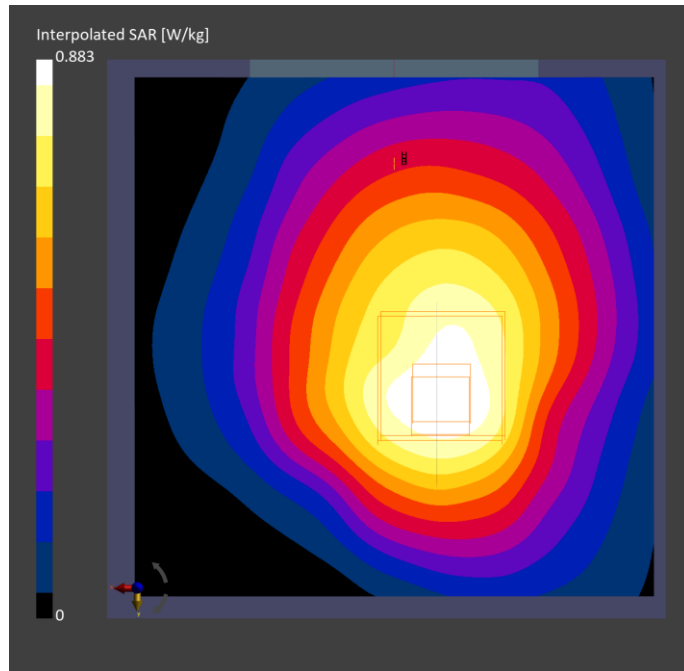

Fig.16 LTE Band 7 Body



LTE Band 12 Head

Exposure Conditions

Phantom Section, TSL	Position, Test Distance [mm]	Band	Group, UID	Frequency [MHz], Channel Number	Conversion Factor	TSL Conductivity [S/m]	TSL Permittivity
Left Head, HSL	CHEEK, 0.00	Band 12	LTE-FDD, 10175-CAH	711.0, 23130	11.02	0.86	42.8

Hardware Setup

Phantom	TSL, Measured Date	Probe, Calibration Date	DAE, Calibration Date
Twin-SAM V8.0 (30deg probe tilt) - 2130	750MHz-Head Charge:2024-06-25	EX3DV4 - SN7621, 2024-01-10	DAE4 Sn786, 2023-12-11

Scans Setup

	Area Scan	Zoom Scan
Grid Extents [mm]	90.0 x 120.0	32.0 x 32.0 x 30.0
Grid Steps [mm]	15.0 x 15.0	8.0 x 8.0 x 5.0
Sensor Surface [mm]	3.0	1.4
Graded Grid	n/a	Yes
Grading Ratio	n/a	1.5
MAIA	N/A	N/A
Surface Detection	All points	All points
Scan Method	Measured	Measured

Measurement Results

	Area Scan	Zoom Scan
Date	2024-06-25	2024-06-25
psSAR1g [W/Kg]	0.308	0.389
psSAR10g [W/Kg]	0.212	0.289
Power Drift [dB]	0.07	0.05
Power Scaling	Disabled	Disabled
Scaling Factor [dB]		
TSL Correction	No correction	No correction
M2/M1 [%]		75.8
Dist 3dB Peak [mm]		> 16.0

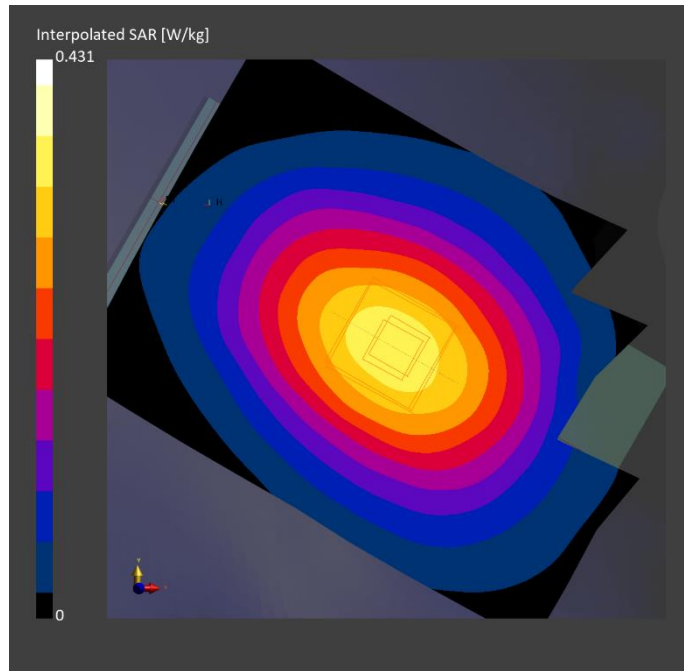

Fig.17 LTE Band 12 Head



LTE Band 12 Body

Exposure Conditions

Phantom Section, TSL	Position, Test Distance [mm]	Band	Group, UID	Frequency [MHz], Channel Number	Conversion Factor	TSL Conductivity [S/m]	TSL Permittivity
Flat, HSL	BACK, 15.00	Band 12	LTE-FDD, 10175-CAH	711.0, 23130	11.02	0.86	42.8

Hardware Setup

Phantom	TSL, Measured Date	Probe, Calibration Date	DAE, Calibration Date
Twin-SAM V8.0 (30deg probe tilt) - 2130	750MHz-Head Charge:2024-06-25	EX3DV4 - SN7621, 2024-01-10	DAE4 Sn786, 2023-12-11

Scans Setup

	Area Scan	Zoom Scan
Grid Extents [mm]	90.0 x 90.0	32.0 x 32.0 x 30.0
Grid Steps [mm]	15.0 x 15.0	8.0 x 8.0 x 5.0
Sensor Surface [mm]	3.0	1.4
Graded Grid	n/a	Yes
Grading Ratio	n/a	1.5
MAIA	N/A	N/A
Surface Detection	All points	All points
Scan Method	Measured	Measured

Measurement Results

	Area Scan	Zoom Scan
Date	2024-06-25	2024-06-25
psSAR1g [W/Kg]	0.293	0.308
psSAR10g [W/Kg]	0.205	0.220
Power Drift [dB]	-0.06	0.16
Power Scaling	Disabled	Disabled
Scaling Factor [dB]		
TSL Correction	No correction	No correction
M2/M1 [%]		68.8
Dist 3dB Peak [mm]		> 16.0

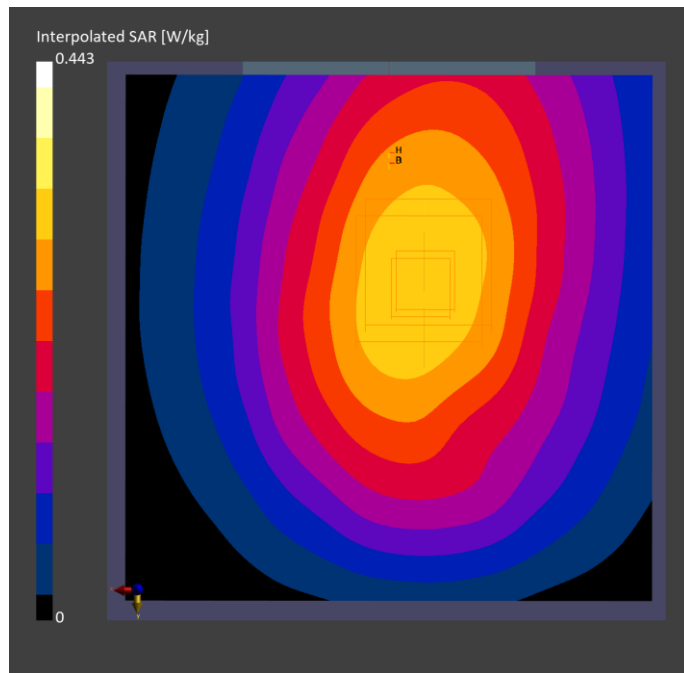

Fig.18 LTE Band 12 Body



LTE Band 13 Head

Exposure Conditions

Phantom Section, TSL	Position, Test Distance [mm]	Band	Group, UID	Frequency [MHz], Channel Number	Conversion Factor	TSL Conductivity [S/m]	TSL Permittivity
Left Head, HSL	CHEEK, 0.00	Band 13	LTE-FDD, 10175-CAH	782.0, 23230	11.02	0.91	42.0

Hardware Setup

Phantom	TSL, Measured Date	Probe, Calibration Date	DAE, Calibration Date
Twin-SAM V8.0 (30deg probe tilt) - 2130	750MHz-Head Charge:2024-06-25	EX3DV4 - SN7621, 2024-01-10	DAE4 Sn786, 2023-12-11

Scans Setup

	Area Scan	Zoom Scan
Grid Extents [mm]	90.0 x 90.0	32.0 x 32.0 x 30.0
Grid Steps [mm]	15.0 x 15.0	8.0 x 8.0 x 5.0
Sensor Surface [mm]	3.0	1.4
Graded Grid	n/a	Yes
Grading Ratio	n/a	1.5
MAIA	N/A	N/A
Surface Detection	All points	All points
Scan Method	Measured	Measured

Measurement Results

	Area Scan	Zoom Scan
Date	2024-06-25	2024-06-25
psSAR1g [W/Kg]	0.718	0.768
psSAR10g [W/Kg]	0.491	0.559
Power Drift [dB]	-0.04	-0.11
Power Scaling	Disabled	Disabled
Scaling Factor [dB]		
TSL Correction	No correction	No correction
M2/M1 [%]		76.1
Dist 3dB Peak [mm]		6.5

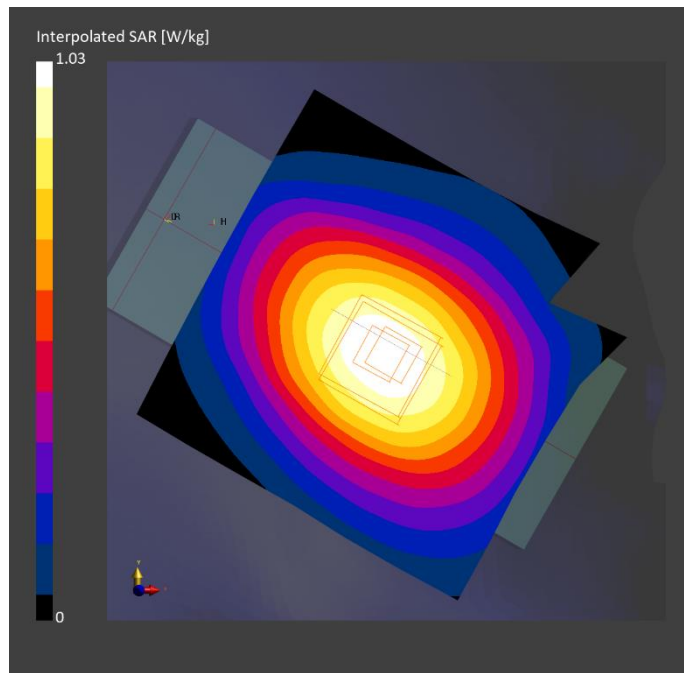

Fig.19 LTE Band 13 Head



LTE Band 13 Body

Exposure Conditions

Phantom Section, TSL	Position, Test Distance [mm]	Band	Group, UID	Frequency [MHz], Channel Number	Conversion Factor	TSL Conductivity [S/m]	TSL Permittivity
Flat, HSL	BACK, 15.00	Band 13	LTE-FDD, 10175-CAH	782.0, 23230	11.02	0.91	42.0

Hardware Setup

Phantom	TSL, Measured Date	Probe, Calibration Date	DAE, Calibration Date
Twin-SAM V8.0 (30deg probe tilt) - 2130	750MHz-Head Charge:2024-06-25	EX3DV4 - SN7621, 2024-01-10	DAE4 Sn786, 2023-12-11

Scans Setup

	Area Scan	Zoom Scan
Grid Extents [mm]	90.0 x 90.0	32.0 x 32.0 x 30.0
Grid Steps [mm]	15.0 x 15.0	8.0 x 8.0 x 5.0
Sensor Surface [mm]	3.0	1.4
Graded Grid	n/a	Yes
Grading Ratio	n/a	1.5
MAIA	N/A	N/A
Surface Detection	All points	All points
Scan Method	Measured	Measured

Measurement Results

	Area Scan	Zoom Scan
Date	2024-06-25	2024-06-25
psSAR1g [W/Kg]	0.623	0.647
psSAR10g [W/Kg]	0.432	0.465
Power Drift [dB]	-0.04	0.15
Power Scaling	Disabled	Disabled
Scaling Factor [dB]		
TSL Correction	No correction	No correction
M2/M1 [%]		69.3
Dist 3dB Peak [mm]		> 16.0

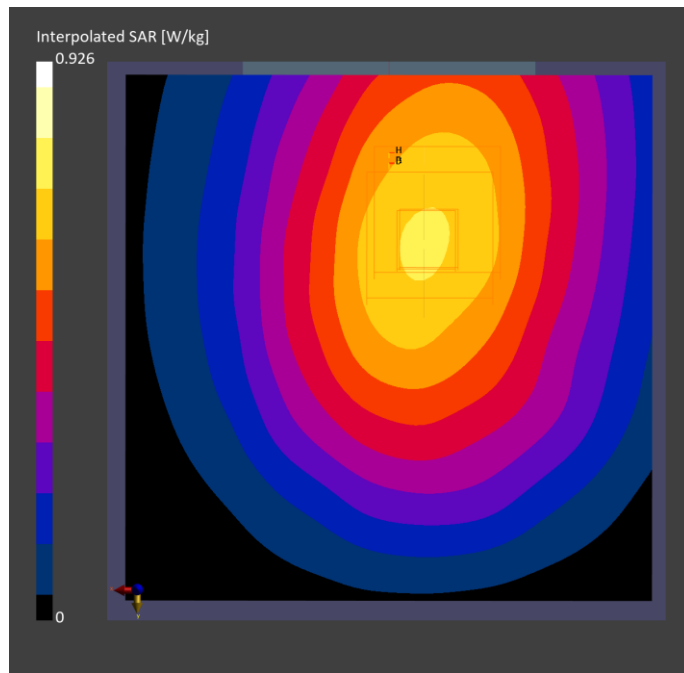

Fig.20 LTE Band 13 Body



LTE Band 66 Head

Exposure Conditions

Phantom Section, TSL	Position, Test Distance [mm]	Band	Group, UID	Frequency [MHz], Channel Number	Conversion Factor	TSL Conductivity [S/m]	TSL Permittivity
Right Head, HSL	CHEEK, 0.00	Band 66	LTE-FDD, 10169-CAF	1770.0, 132572	9.11	1.41	39.4

Hardware Setup

Phantom	TSL, Measured Date	Probe, Calibration Date	DAE, Calibration Date
Twin-SAM V8.0 (30deg probe tilt) - 2130	1750MHz-Head Charge:2024-06-21	EX3DV4 - SN7621, 2024-01-10	DAE4 Sn786, 2023-12-11

Scans Setup

	Area Scan	Zoom Scan
Grid Extents [mm]	90.0 x 120.0	32.0 x 32.0 x 30.0
Grid Steps [mm]	15.0 x 15.0	8.0 x 8.0 x 5.0
Sensor Surface [mm]	3.0	1.4
Graded Grid	n/a	Yes
Grading Ratio	n/a	1.5
MAIA	N/A	N/A
Surface Detection	VMS + 6p	VMS + 6p
Scan Method	Measured	Measured

Measurement Results

	Area Scan	Zoom Scan
Date	2024-06-21	2024-06-21
psSAR1g [W/Kg]	0.302	0.293
psSAR10g [W/Kg]	0.182	0.198
Power Drift [dB]	-0.04	0.07
Power Scaling	Disabled	Disabled
Scaling Factor [dB]		
TSL Correction	No correction	No correction
M2/M1 [%]		70.9
Dist 3dB Peak [mm]		18.7

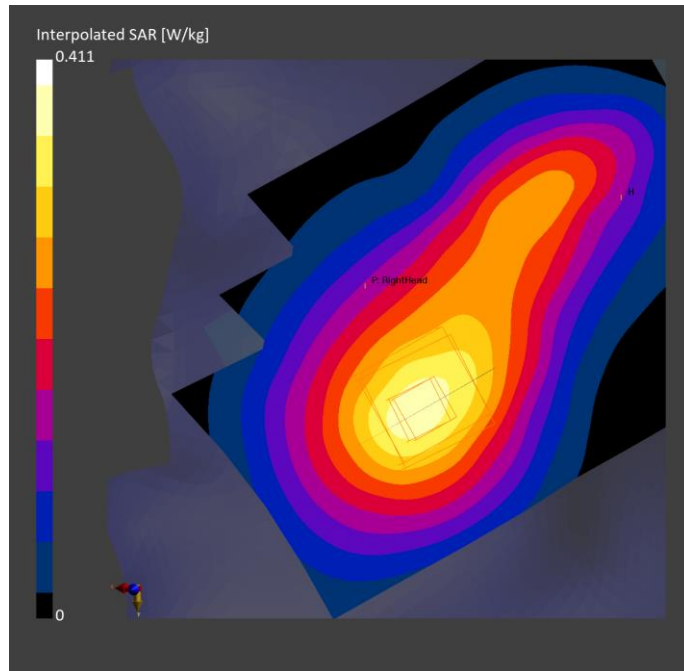

Fig.21 LTE Band 66 Head



LTE Band 66 Body

Exposure Conditions

Phantom Section, TSL	Position, Test Distance [mm]	Band	Group, UID	Frequency [MHz], Channel Number	Conversion Factor	TSL Conductivity [S/m]	TSL Permittivity
Flat, HSL	BACK, 15.00	Band 66	LTE-FDD, 10169-CAF	1720.0, 132072	9.11	1.36	39.6

Hardware Setup

Phantom	TSL, Measured Date	Probe, Calibration Date	DAE, Calibration Date
Twin-SAM V8.0 (30deg probe tilt) - 2130	1750MHz-Head Charge:2024-06-21	EX3DV4 - SN7621, 2024-01-10	DAE4 Sn786, 2023-12-11

Scans Setup

	Area Scan	Zoom Scan
Grid Extents [mm]	90.0 x 90.0	32.0 x 32.0 x 30.0
Grid Steps [mm]	15.0 x 15.0	8.0 x 8.0 x 5.0
Sensor Surface [mm]	3.0	1.4
Graded Grid	n/a	Yes
Grading Ratio	n/a	1.5
MAIA	N/A	N/A
Surface Detection	All points	All points
Scan Method	Measured	Measured

Measurement Results

	Area Scan	Zoom Scan
Date	2024-06-21	2024-06-21
psSAR1g [W/Kg]	0.673	0.712
psSAR10g [W/Kg]	0.395	0.406
Power Drift [dB]	-0.08	-0.06
Power Scaling	Disabled	Disabled
Scaling Factor [dB]		
TSL Correction	No correction	No correction
M2/M1 [%]		57.8
Dist 3dB Peak [mm]		13.7

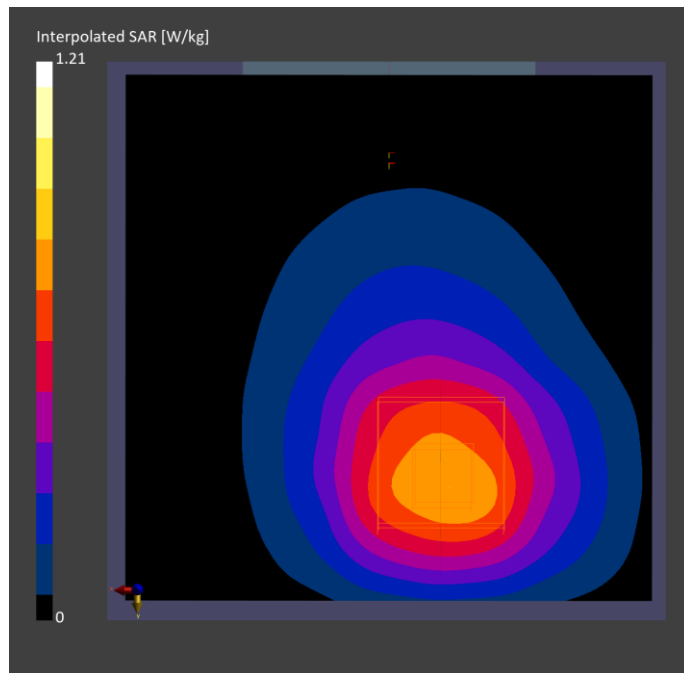

Fig.22 LTE Band 66 Body

Bluetooth Head

Date: 2024-07-09

Electronics: DAE4 Sn786

Medium: Head 2450MHz

Medium parameters used: $f = 2480$ MHz; $\sigma = 1.818$ S/m; $\epsilon_r = 39.688$; $\rho = 1000$ kg/m³

Communication System: UID 0, BT (0) Frequency: 2480 MHz Duty Cycle: 1:1

Probe: EX3DV4 - SN7621 ConvF (8.21, 8.21, 8.21)

Left Cheek Ch.78/Area Scan (91x111x1): Interpolated grid: dx=1.000 mm, dy=1.000 mm

Maximum value of SAR (interpolated) = 0.0829 W/kg

Left Cheek Ch.78/Zoom Scan (7x7x7)/Cube 0: Measurement grid: dx=5mm, dy=5mm, dz=5mm

Reference Value = 3.717 V/m; Power Drift = 0.09 dB

Peak SAR (extrapolated) = 0.0940 W/kg

SAR(1 g) = 0.050 W/kg; SAR(10 g) = 0.026 W/kg

Maximum value of SAR (measured) = 0.0712 W/kg

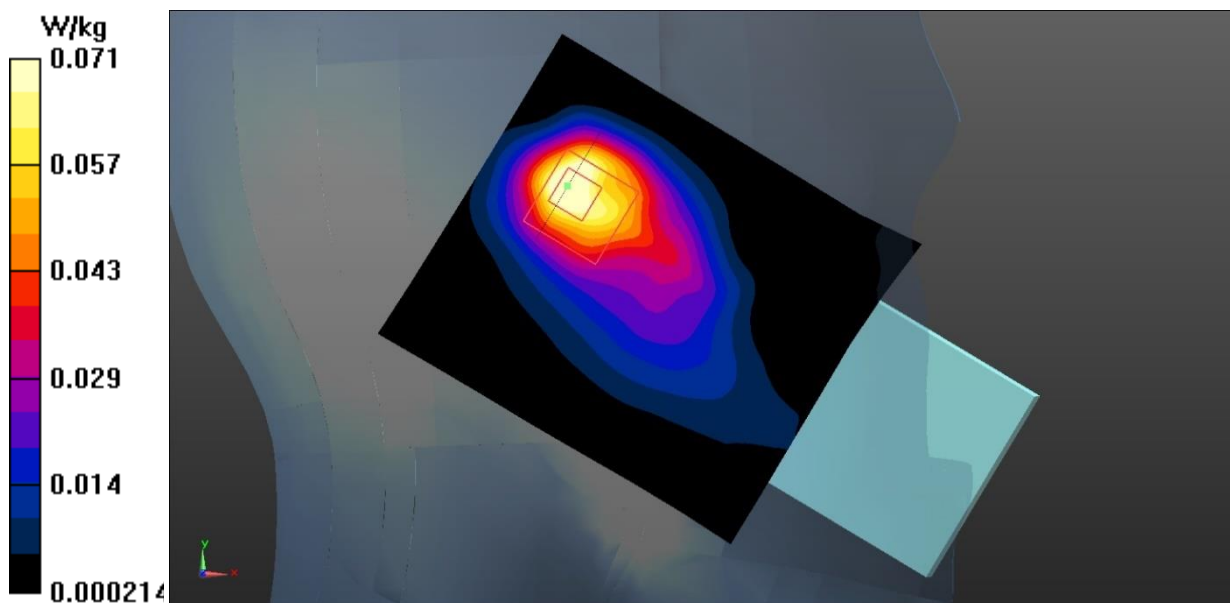

Fig.23 Bluetooth Head

Bluetooth Body

Date: 2024-07-09

Electronics: DAE4 Sn786

Medium: Head 2450MHz

Medium parameters used: $f = 2480$ MHz; $\sigma = 1.818$ S/m; $\epsilon_r = 39.688$; $\rho = 1000$ kg/m³

Communication System: UID 0, BT (0) Frequency: 2480 MHz Duty Cycle: 1:1

Probe: EX3DV4 - SN7621 ConvF (8.21, 8.21, 8.21)

Front Side Ch.78/Area Scan (91x161x1): Interpolated grid: dx=1.000 mm, dy=1.000 mm

Maximum value of SAR (interpolated) = 0.0107 W/kg

Front Side Ch.78/Zoom Scan (7x7x7)/Cube 0: Measurement grid: dx=5mm, dy=5mm, dz=5mm

Reference Value = 1.571 V/m; Power Drift = -0.06 dB

Peak SAR (extrapolated) = 0.0130 W/kg

SAR(1 g) = 0.00603 W/kg; SAR(10 g) = 0.00305 W/kg

Maximum value of SAR (measured) = 0.00849 W/kg

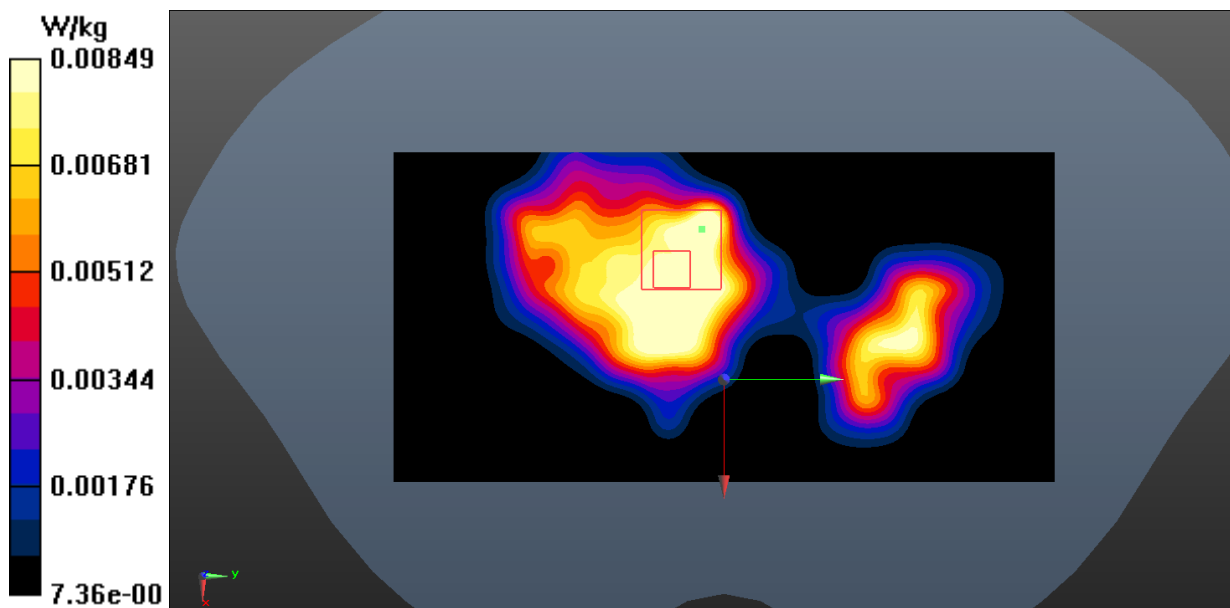

Fig.24 Bluetooth Body



ANNEX B: System Verification Results

750MHz

Exposure Conditions

Phantom Section, TSL	Position, Test Distance [mm]	Band	Group, UID	Frequency [MHz], Channel Number	Conversion Factor	TSL Conductivity [S/m]	TSL Permittivity
Flat, HSL	FRONT, 10.00	D750	CW, 0--	750.0, 50	11.02	0.89	42.4

Hardware Setup

Phantom	TSL, Measured Date	Probe, Calibration Date	DAE, Calibration Date
Twin-SAM V8.0 (30deg probe tilt) - 2130	750MHz-Head Charge:2024-06-25	EX3DV4 - SN7621, 2024-01-10	DAE4 Sn786, 2023-12-11

Scans Setup

	Area Scan	Zoom Scan
Grid Extents [mm]	60.0 x 210.0	30.0 x 30.0 x 30.0
Grid Steps [mm]	10.0 x 10.0	5.0 x 5.0 x 5.0
Sensor Surface [mm]	3.0	1.4
Graded Grid	n/a	Yes
Grading Ratio	n/a	1.5
MAIA	N/A	N/A
Surface Detection	All points	All points
Scan Method	Measured	Measured

Measurement Results

	Area Scan	Zoom Scan
Date	2024-06-25	2024-06-25
psSAR1g [W/Kg]	2.09	2.04
psSAR10g [W/Kg]	1.42	1.36
Power Drift [dB]	-0.07	-0.12
Power Scaling	Disabled	Disabled
Scaling Factor [dB]		
TSL Correction	No correction	No correction
M2/M1 [%]		62.0
Dist 3dB Peak [mm]		17.9

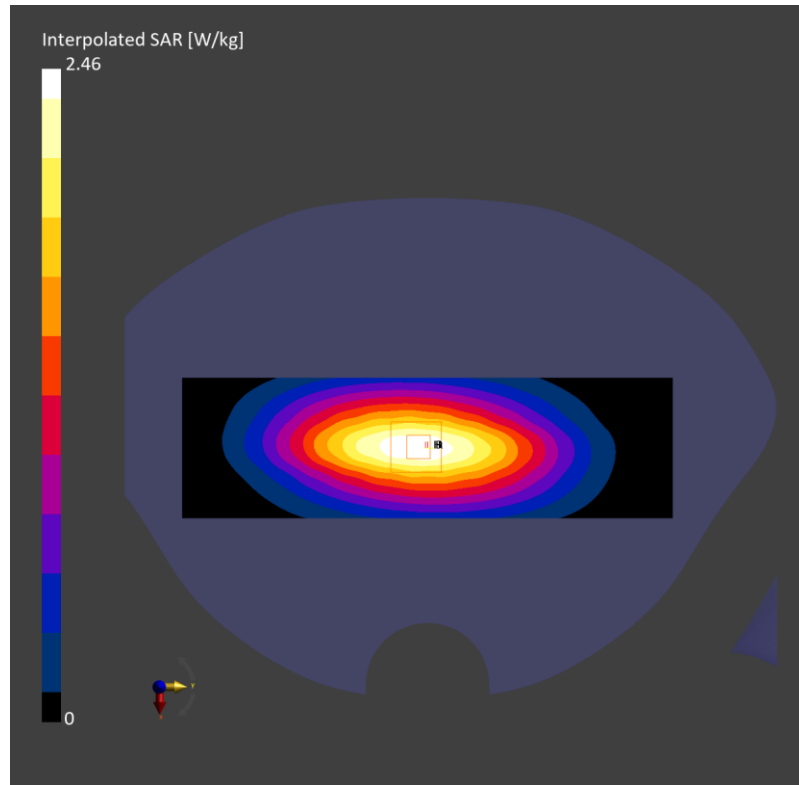

Fig.B.1. Validation 750MHz 250mW



835MHz

Exposure Conditions

Phantom Section, TSL	Position, Test Distance [mm]	Band	Group, UID	Frequency [MHz], Channel Number	Conversion Factor	TSL Conductivity [S/m]	TSL Permittivity
Flat, HSL	FRONT, 10.00	D835	CW, 0--	900.0, 50	11.02	0.91	40.6

Hardware Setup

Phantom	TSL, Measured Date	Probe, Calibration Date	DAE, Calibration Date
Twin-SAM V8.0 (30deg probe tilt) - 2130	835MHz-Head Charge:2024-07-05	EX3DV4 - SN7621, 2024-01-10	DAE4 Sn786, 2023-12-11

Scans Setup

	Area Scan	Zoom Scan
Grid Extents [mm]	60.0 x 210.0	30.0 x 30.0 x 30.0
Grid Steps [mm]	10.0 x 10.0	5.0 x 5.0 x 5.0
Sensor Surface [mm]	3.0	1.4
Graded Grid	n/a	Yes
Grading Ratio	n/a	1.5
MAIA	N/A	N/A
Surface Detection	All points	All points
Scan Method	Measured	Measured

Measurement Results

	Area Scan	Zoom Scan
Date	2024-07-05	2024-07-05
psSAR1g [W/Kg]	2.41	2.48
psSAR10g [W/Kg]	1.57	1.60
Power Drift [dB]	0.05	0.13
Power Scaling	Disabled	Disabled
Scaling Factor [dB]		
TSL Correction	No correction	No correction
M2/M1 [%]		61.6
Dist 3dB Peak [mm]		16.4

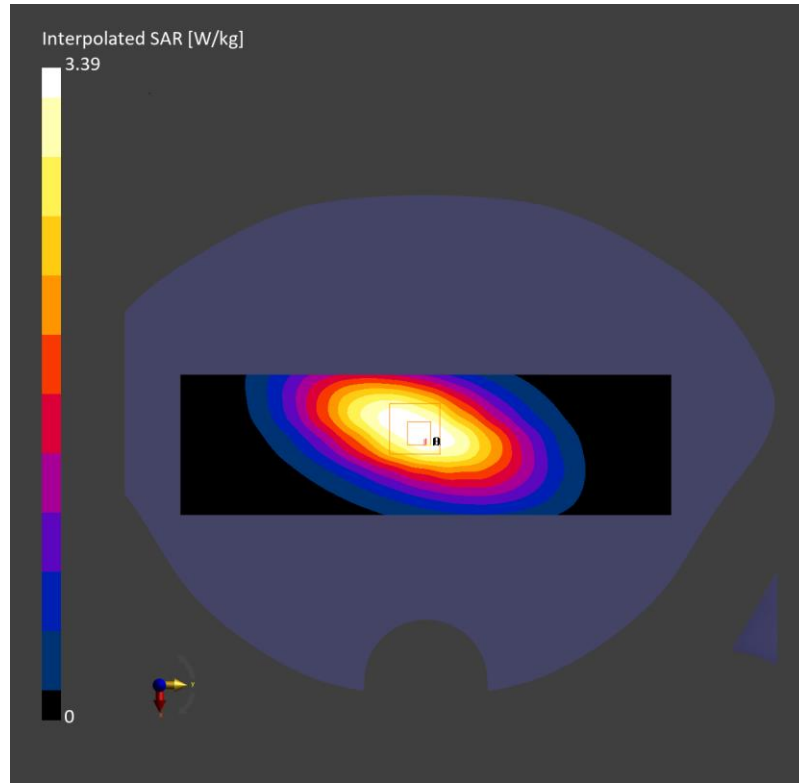

Fig.B.2. Validation 835MHz 250mW



1750MHz

Exposure Conditions

Phantom Section, TSL	Position, Test Distance [mm]	Band	Group, UID	Frequency [MHz], Channel Number	Conversion Factor	TSL Conductivity [S/m]	TSL Permittivity
Flat, HSL	FRONT, 10.00	D1750	CW, 0--	1750.0, 50	9.11	1.39	39.4

Hardware Setup

Phantom	TSL, Measured Date	Probe, Calibration Date	DAE, Calibration Date
Twin-SAM V8.0 (30deg probe tilt) - 2130	1750MHz-Head Charge:2024-06-21	EX3DV4 - SN7621, 2024-01-10	DAE4 Sn786, 2023-12-11

Scans Setup

	Area Scan	Zoom Scan
Grid Extents [mm]	60.0 x 210.0	30.0 x 30.0 x 30.0
Grid Steps [mm]	10.0 x 10.0	5.0 x 5.0 x 5.0
Sensor Surface [mm]	3.0	1.4
Graded Grid	n/a	Yes
Grading Ratio	n/a	1.5
MAIA	N/A	N/A
Surface Detection	All points	All points
Scan Method	Measured	Measured

Measurement Results

	Area Scan	Zoom Scan
Date	2024-06-21	2024-06-21
psSAR1g [W/Kg]	9.32	9.21
psSAR10g [W/Kg]	5.24	4.95
Power Drift [dB]	-0.05	-0.08
Power Scaling	Disabled	Disabled
Scaling Factor [dB]		
TSL Correction	No correction	No correction
M2/M1 [%]		53.7
Dist 3dB Peak [mm]		10.8

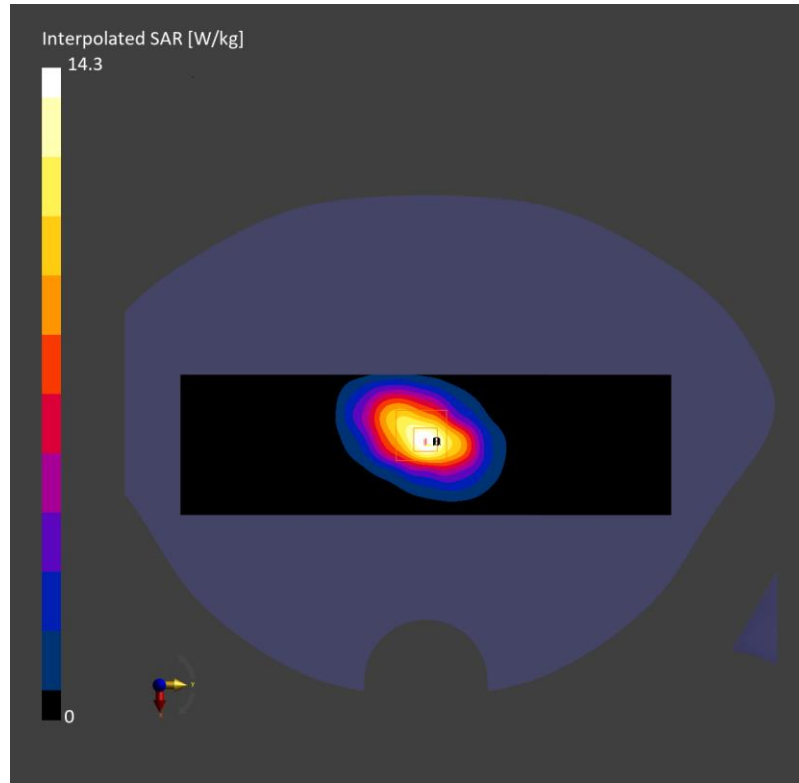

Fig.B.3. Validation 1750MHz 250mW



1900MHz

Exposure Conditions

Phantom Section, TSL	Position, Test Distance [mm]	Band	Group, UID	Frequency [MHz], Channel Number	Conversion Factor	TSL Conductivity [S/m]	TSL Permittivity
Flat, HSL	FRONT, 10.00	D1900	CW, 0--	1900.0, 50	8.76	1.43	39.2

Hardware Setup

Phantom	TSL, Measured Date	Probe, Calibration Date	DAE, Calibration Date
Twin-SAM V8.0 (30deg probe tilt) - 2130	1900MHz-Head Charge:2024-07-07	EX3DV4 - SN7621, 2024-01-10	DAE4 Sn786, 2023-12-11

Scans Setup

	Area Scan	Zoom Scan
Grid Extents [mm]	60.0 x 120.0	30.0 x 30.0 x 30.0
Grid Steps [mm]	10.0 x 10.0	5.0 x 5.0 x 5.0
Sensor Surface [mm]	3.0	1.4
Graded Grid	n/a	Yes
Grading Ratio	n/a	1.5
MAIA	N/A	N/A
Surface Detection	All points	All points
Scan Method	Measured	Measured

Measurement Results

	Area Scan	Zoom Scan
Date	2024-07-07	2024-07-07
psSAR1g [W/Kg]	10.2	10.4
psSAR10g [W/Kg]	5.10	5.26
Power Drift [dB]	0.04	0.08
Power Scaling	Disabled	Disabled
Scaling Factor [dB]		
TSL Correction	No correction	No correction
M2/M1 [%]		53.2
Dist 3dB Peak [mm]		9.7

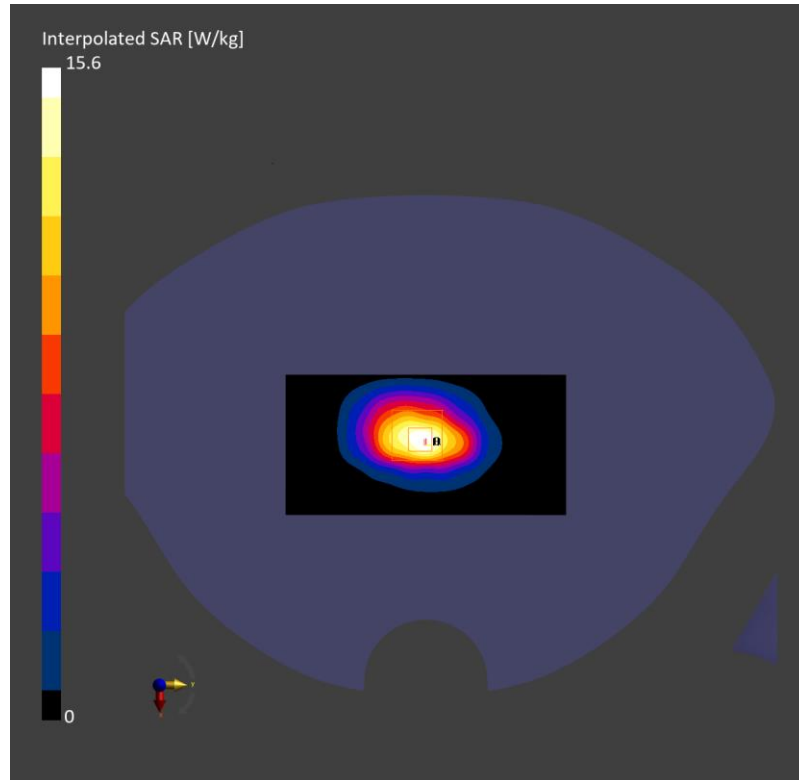

Fig.B.4. Validation 1900MHz 250mW

2450MHz

Date: 2024-07-09

Electronics: DAE4 Sn786

Medium: Head 2450MHz

Medium parameters used: $f = 2450 \text{ MHz}$; $\sigma = 1.783 \text{ S/m}$; $\epsilon_r = 39.787$; $\rho = 1000 \text{ kg/m}^3$

Communication System: CW Frequency: 2450 MHz Duty Cycle: 1:1

Probe: EX3DV4 - SN7621 ConvF (8.21, 8.21, 8.21)

System Validation/Area Scan (81x121x1): Interpolated grid: $dx=1.000 \text{ mm}$, $dy=1.000 \text{ mm}$

Reference Value = 93.578 V/m; Power Drift = -0.13 dB

SAR(1 g) = 13.4 W/kg; SAR(10 g) = 6.10 W/kg

Maximum value of SAR (interpolated) = 21.4 W/kg

System Validation/Zoom Scan (7x7x7)/Cube0: Measurement grid: $dx=5\text{mm}$, $dy=5\text{mm}$, $dz=5\text{mm}$

Reference Value = 93.578 V/m; Power Drift = -0.13 dB

Peak SAR (extrapolated) = 30.2 W/kg

SAR(1 g) = 13.1 W/kg; SAR(10 g) = 6.03 W/kg

Maximum value of SAR (measured) = 21.1 W/kg

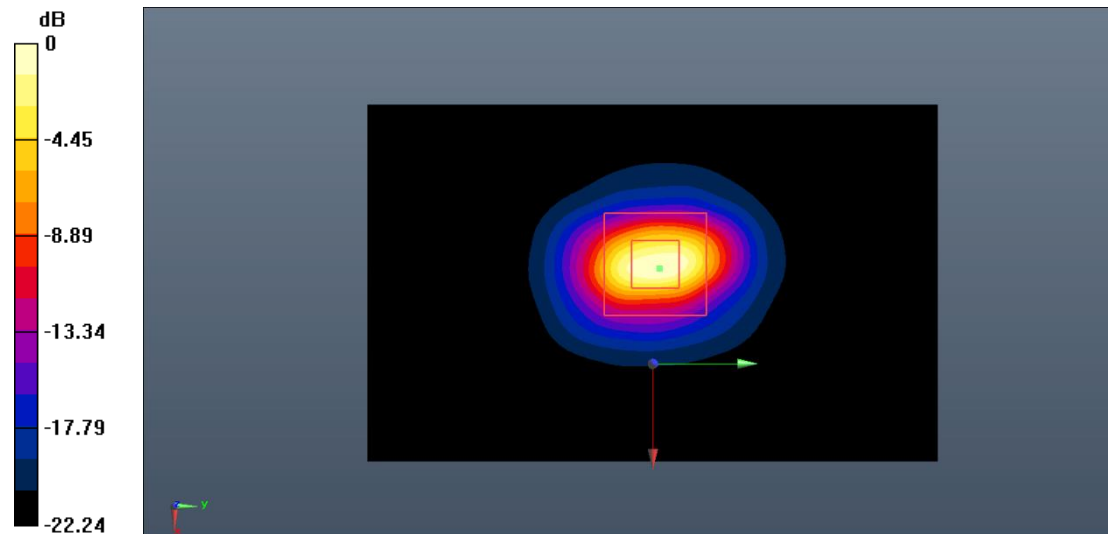

0 dB = 21.1 W/kg = 13.24 dB W/kg

Fig.B.5. Validation 2450MHz 250mW



2550MHz

Exposure Conditions

Phantom Section, TSL	Position, Test Distance [mm]	Band	Group, UID	Frequency [MHz], Channel Number	Conversion Factor	TSL Conductivity [S/m]	TSL Permittivity
Flat, HSL	FRONT, 10.00	D2550	CW, 0--	2550.0, 50	8.21	1.95	38.2

Hardware Setup

Phantom	TSL, Measured Date	Probe, Calibration Date	DAE, Calibration Date
Twin-SAM V8.0 (30deg probe tilt) - 2130	2550MHz-Head Charge:2024-07-03	EX3DV4 - SN7621, 2024-01-10	DAE4 Sn786, 2023-12-11

Scans Setup

	Area Scan	Zoom Scan
Grid Extents [mm]	60.0 x 120.0	30.0 x 30.0 x 30.0
Grid Steps [mm]	10.0 x 10.0	5.0 x 5.0 x 5.0
Sensor Surface [mm]	3.0	1.4
Graded Grid	n/a	Yes
Grading Ratio	n/a	1.5
MAIA	N/A	N/A
Surface Detection	All points	All points
Scan Method	Measured	Measured

Measurement Results

	Area Scan	Zoom Scan
Date	2024-07-03	2024-07-03
psSAR1g [W/Kg]	13.8	14.2
psSAR10g [W/Kg]	6.24	6.38
Power Drift [dB]	0.09	0.02
Power Scaling	Disabled	Disabled
Scaling Factor [dB]		
TSL Correction	No correction	No correction
M2/M1 [%]		48.1
Dist 3dB Peak [mm]		9.4

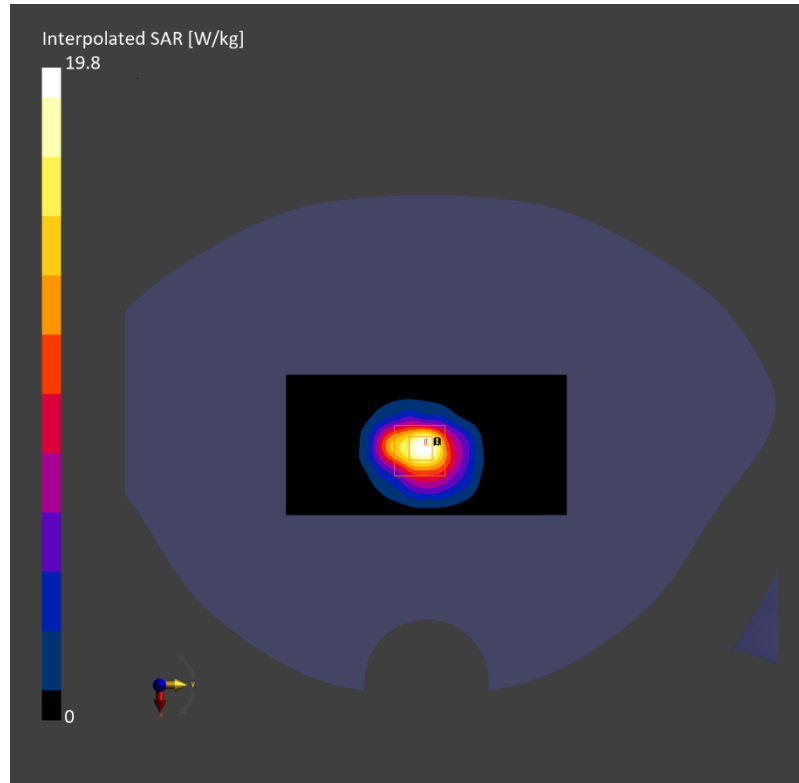
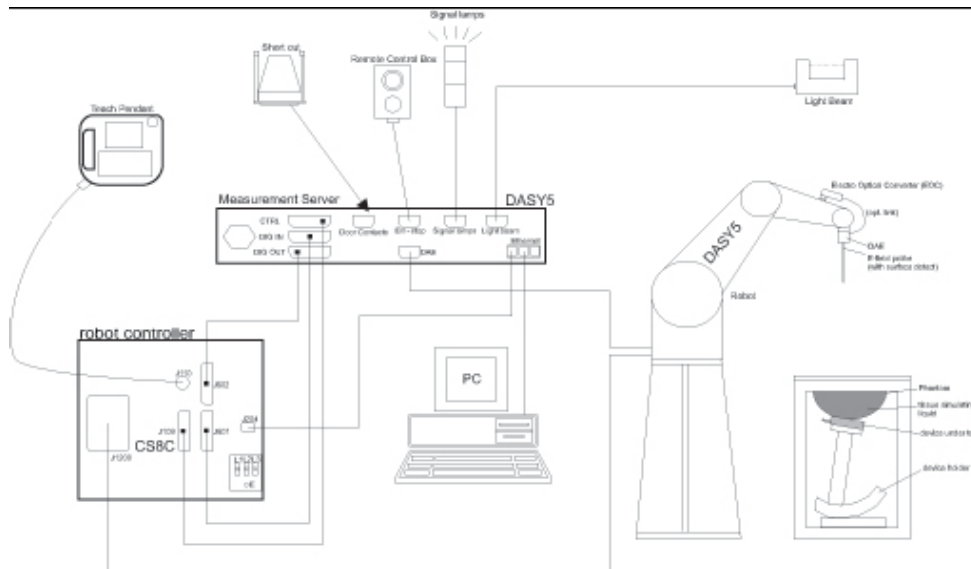

Fig.B.6. Validation 2550MHz 250mW

ANNEX C: SAR Measurement Setup

C.1. Measurement Set-up

DASY5 system for performing compliance tests is illustrated above graphically. This system consists of the following items:



Picture C.1 SAR Lab Test Measurement Set-up

- A standard high precision 6-axis robot (Stäubli TX=RX family) with controller, teach pendant and software. An arm extension for accommodating the data acquisition electronics (DAE).
- An isotropic field probe optimized and calibrated for the targeted measurement.
- A data acquisition electronics (DAE) which performs the signal amplification, signal multiplexing, AD-conversion, offset measurements, mechanical surface detection, collision detection, etc. The unit is battery powered with standard or rechargeable batteries. The signal is optically transmitted to the EOC.
- The Electro-optical converter (EOC) performs the conversion from optical to electrical signals for the digital communication to the DAE. To use optical surface detection, a special version of the EOC is required. The EOC signal is transmitted to the measurement server.
- The function of the measurement server is to perform the time critical tasks such as signal filtering, control of the robot operation and fast movement interrupts.
- The Light Beam used is for probe alignment. This improves the (absolute) accuracy of the probe positioning.
- A computer running WinXP and the DASY5 software.
- Remote control and teach pendant as well as additional circuitry for robot safety such as
- warning lamps, etc.
- The phantom, the device holder and other accessories according to the targeted measurement.

C.2. DASY E-field Probe System

The SAR measurements were conducted with the dosimetric probe designed in the classical triangular configuration and optimized for dosimetric evaluation. The probe is constructed using the thick film technique; with printed resistive lines on ceramic substrates. The probe is equipped with an optical multifiber line ending at the front of the probe tip. It is connected to the EOC box on the robot arm and provides an automatic detection of the phantom surface. Half of the fibers are connected to a pulsed infrared transmitter, the other half to a synchronized receiver. As the probe approaches the surface, the reflection from the surface produces a coupling from the transmitting to the receiving fibers. This reflection increases first during the approach, reaches maximum and then decreases. If the probe is flatly touching the surface, the coupling is zero. The distance of the coupling maximum to the surface is independent of the surface reflectivity and largely independent of the surface to probe angle. The DASY5 OR DASY8 software reads the reflection during a software approach and looks for the maximum using 2nd order curve fitting. The approach is stopped at reaching the maximum.

Probe Specifications:	
Model:	EX3DV4
Frequency Range:	10 MHz - 6.0 GHz
Calibration:	In head simulating tissue at Frequencies from 750 up to 5750 MHz
Linearity:	± 0.2 dB (30 MHz to 6 GHz)
Dynamic Range:	10 mW/kg - 100 W/kg
Probe Length:	337 mm
Probe Tip Length:	20 mm
Body Diameter:	12 mm
Tip Diameter:	2.5 mm
Tip-Center:	1 mm
Application:	SAR Dosimetry Testing / Compliance tests of mobile phones / Dosimetry in strong gradient fields

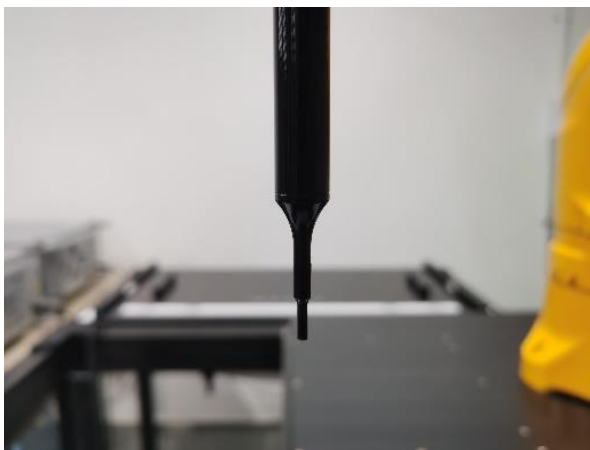

Picture C.2: Near-field Probe

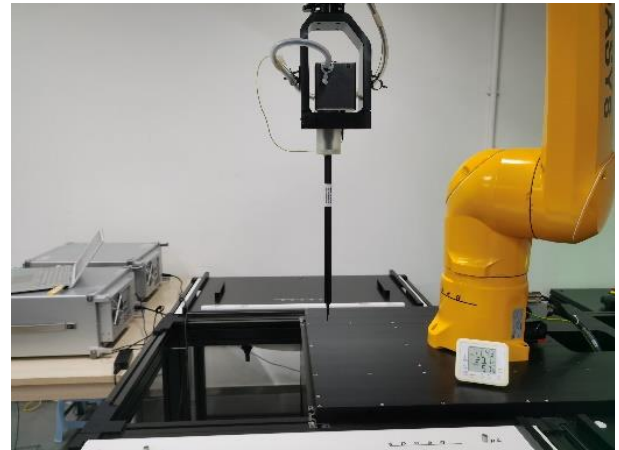

Picture C.3: E-field Probe

C.3. E-field Probe Calibration

Each E-Probe/Probe Amplifier combination has unique calibration parameters. A TEM cell calibration procedure is conducted to determine the proper amplifier settings to enter in the probe parameters. The amplifier settings are determined for a given frequency by subjecting the probe to a known E-field density (1 mW/cm²) using an RF Signal generator, TEM cell, and RF Power Meter.

The free space E-field from amplified probe outputs is determined in a test chamber. This calibration can be performed in a TEM cell if the frequency is below 1 GHz and in a waveguide or other methodologies above 1 GHz for free space. For the free space calibration, the probe is placed in the volumetric center of the cavity and at the proper orientation with the field. The probe is then rotated 360 degrees until the three channels show the maximum reading. The power density readings equate to 1 mW/cm².

E-field temperature correlation calibration is performed in a flat phantom filled with the appropriate simulated brain tissue. The E-field in the medium correlates with the temperature rise in the dielectric medium. For temperature correlation calibration a RF transparent thermistor-based temperature probe is used in conjunction with the E-field probe.

$$SAR = C \frac{\Delta T}{\Delta t}$$

Where:

Δt = Exposure time (30 seconds),

C = Heat capacity of tissue (brain or muscle),

ΔT = Temperature increase due to RF exposure.

$$SAR = \frac{|E|^2 \cdot \sigma}{\rho}$$

Where:

σ = Simulated tissue conductivity,

ρ = Tissue density (kg/m³).

C.4. Other Test Equipment

C.4.1. Data Acquisition Electronics (DAE)

The data acquisition electronics consist of a highly sensitive electrometer-grade preamplifier with auto-zeroing, a channel and gain-switching multiplexer, a fast 16 bit AD-converter and a command decoder with a control logic unit. Transmission to the measurement server is accomplished through an optical downlink for data and status information, as well as an optical uplink for commands and the clock.

The mechanical probe mounting device includes two different sensor systems for frontal and sideways probe contacts. They are used for mechanical surface detection and probe collision detection.

The input impedance of the DAE is 200 MOhm; the inputs are symmetrical and floating. Common mode rejection is above 80 dB.



Picture C.4: DAE

C.4.2. Robot

The SPEAG DASY system uses the high precision robots (DASY5: RX90L) type from Stäubli SA (France). For the 6-axis controller system, the robot controller version from Stäubli is used. The Stäubli robot series have many features that are important for our application:

- High precision (repeatability 0.02mm)
- High reliability (industrial design)
- Low maintenance costs (virtually maintenance free due to direct drive gears; no belt drives)
- Jerk-free straight movements (brushless synchron motors; no stepper motors)
- Low ELF interference (motor control fields shielded via the closed metallic construction shields)



Picture C.5: DASY 5



Picture C.6: DASY 8

C.4.3. Measurement Server

The Measurement server is based on a PC/104 CPU board with CPU (DASY5: 400 MHz, Intel Celeron), chipdisk (DASY5:128MB), RAM (DASY5:128MB). The necessary circuits for communication with the DAE electronic box, as well as the 16 bit AD converter system for optical detection and digital I/O interface are contained on the DASY I/O board, which is directly connected to the PC/104 bus of the CPU board.

The measurement server performs all real-time data evaluation of field measurements and surface detection, controls robot movements and handles safety operation. The PC operating system cannot interfere with these time critical processes. All connections are supervised by a watchdog, and disconnection of any of the cables to the measurement server will automatically disarm the robot and disable all program-controlled robot movements. Furthermore, the measurement server is equipped with an expansion port which is reserved for future applications. Please note that this expansion port does not have a standardized pinout, and therefore only devices provided by SPEAG can be connected. Devices from any other supplier could seriously damage the measurement server.



Picture C.7: Server for DASY 5



Picture C.8: Server for DASY 8

C.4.4. Device Holder for Phantom

The SAR in the phantom is approximately inversely proportional to the square of the distance between the source and the liquid surface. For a source at 5mm distance, a positioning uncertainty of $\pm 0.5\text{mm}$ would produce a SAR uncertainty of $\pm 20\%$. Accurate device positioning is therefore crucial for accurate and repeatable measurements. The positions in which the devices must be measured are defined by the standards.

The DASY device holder is designed to cope with the different positions given in the standard. It has two scales for device rotation (with respect to the body axis) and device inclination (with respect to the line between the ear reference points). The rotation centers for both scales is the ear reference point (ERP). Thus the device needs no repositioning when changing the angles.

The DASY device holder is constructed of low-loss POM material having the following dielectric parameters: relative permittivity $\epsilon = 3$ and loss tangent $\delta = 0.02$. The amount of dielectric material has been reduced in the closest vicinity of the device, since measurements have suggested that the influence of the clamp on the test results could thus be lowered.

<Laptop Extension Kit>

The extension is lightweight and made of POM, acrylic glass and foam. It fits easily on the upper part of the Mounting Device in place of the phone positioner. The extension is fully compatible with the Twin-SAM and ELI phantoms.

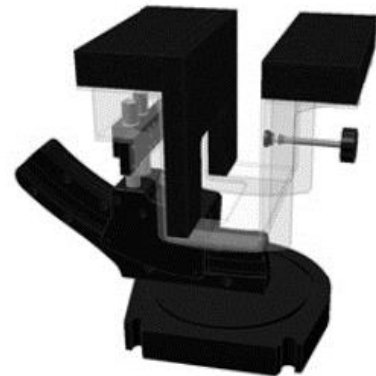
**Picture C.9: Device Holder****Picture C.10: Laptop Extension Kit**

The SAM Twin Phantom V4.0 is constructed of a fiberglass shell integrated in a table. The shape of the shell is based on data from an anatomical study designed to represent the 90th percentile of the population. The phantom enables the dissymmetric evaluation of SAR for both left and right handed handset usage, as well as body-worn usage using the flat phantom region. Reference markings on the Phantom allow the complete setup of all predefined phantom positions and measurement grids by manually teaching three points in the robot. The shell phantom has a 2mm shell thickness (except the ear region where shell thickness increases to 6 mm).

Shell Thickness: 2 ± 0.2 mm
Filling Volume: Approx. 25 liters
Dimensions: 810 x 1000 x 500 mm (H x L x W)
Available: Special

**Picture C.11: SAM Twin Phantom**

ANNEX D: Position of the wireless device in relation to the phantom

D.1. General considerations

This standard specifies two handset test positions against the head phantom – the “cheek” position and the “tilt” position.

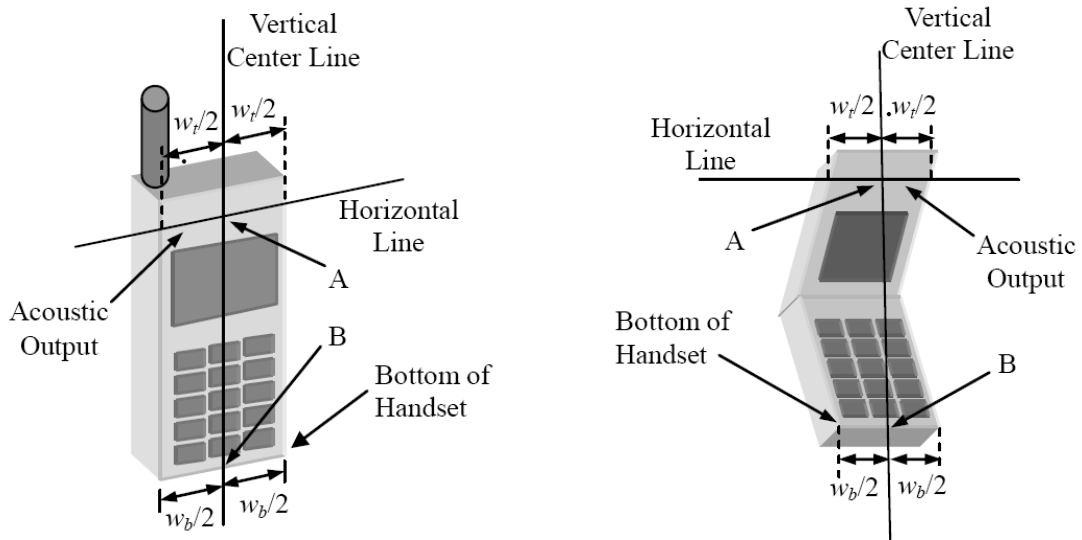

- w_t Width of the handset at the level of the acoustic
- w_b Width of the bottom of the handset
- A Midpoint of the width w_t of the handset at the level of the acoustic output
- B Midpoint of the width w_b of the bottom of the handset

Picture D.1-a Typical “fixed” case handset Picture D.1-b Typical “clam-shell” case handset

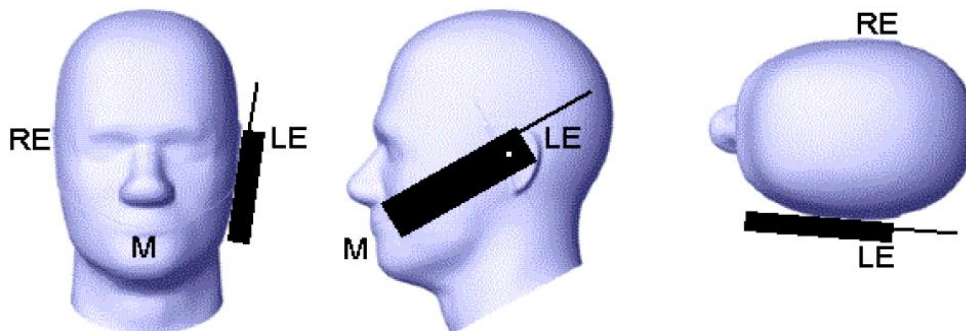

Picture D.2 Cheek position of the wireless device on the left side of SAM

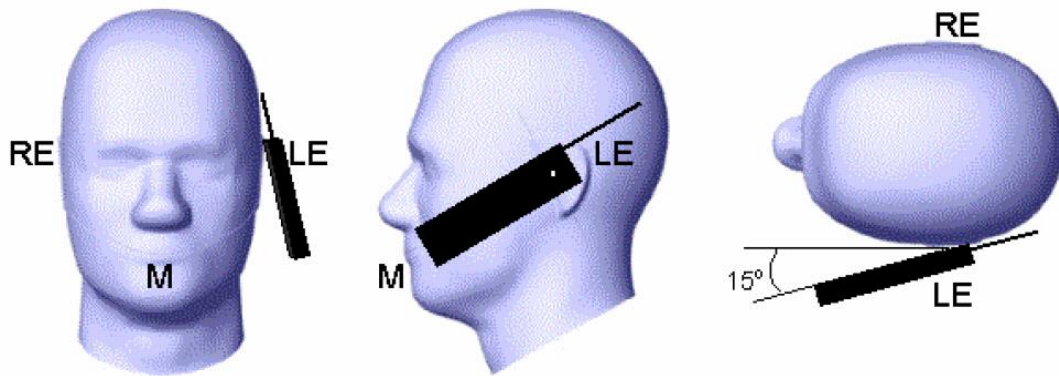

Picture D.3 Tilt position of the wireless device on the left side of SAM

D.2. Body-worn device

A typical example of a body-worn device is a mobile phone, wireless enabled PDA or other battery operated wireless device with the ability to transmit while mounted on a person's body using a carry accessory approved by the wireless device manufacturer.

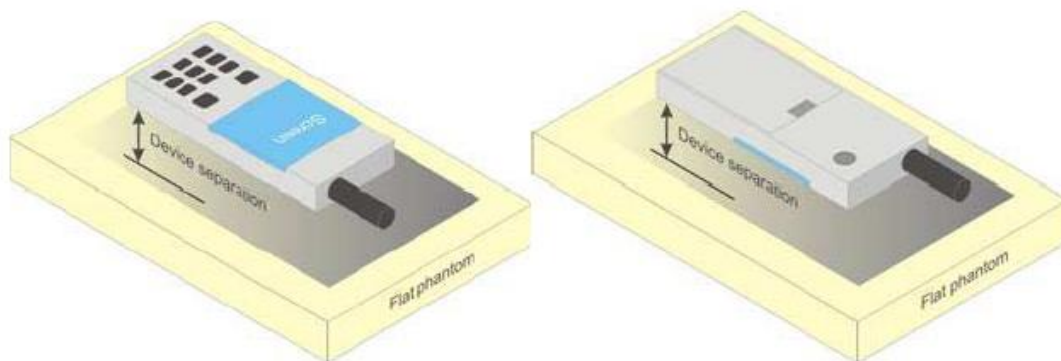

Picture D.4 Test positions for body-worn devices

D.3. Desktop device

A typical example of a desktop device is a wireless enabled desktop computer placed on a table or desk when used.

The DUT shall be positioned at the distance and in the orientation to the phantom that corresponds to the intended use as specified by the manufacturer in the user instructions. For devices that employ an external antenna with variable positions, tests shall be performed for all antenna positions specified. Picture 8.5 show positions for desktop device SAR tests. If the intended use is not specified, the device shall be tested directly against the flat phantom.

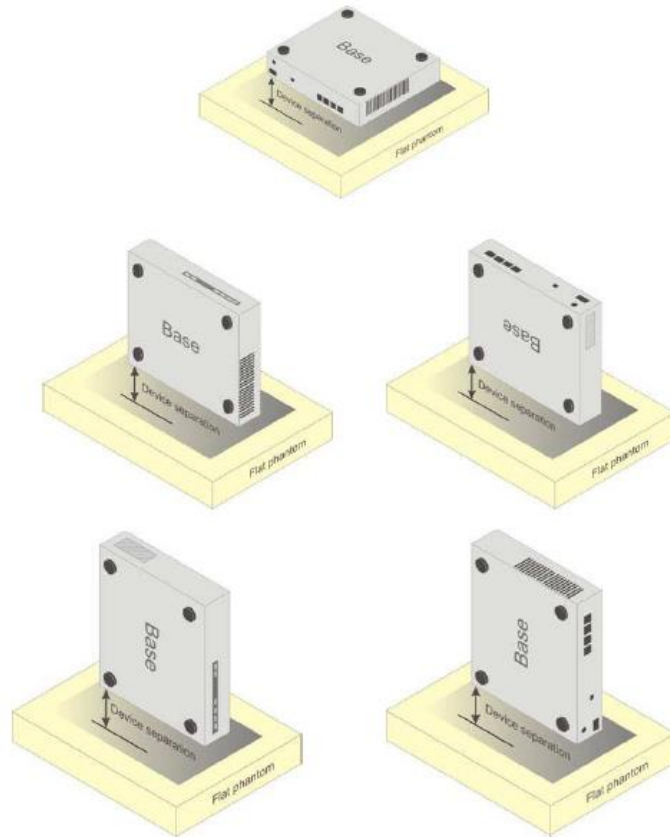

Picture D.5 Test positions for desktop devices

D.4. DUT Setup Photos



Picture D.6 Specific Absorption Rate Test Layout

ANNEX E: Equivalent Media Recipes

The liquid used for the frequency range of 700-6000 MHz consisted of water, sugar, salt, preventol, glycol monobutyl and Cellulose. The liquid has been previously proven to be suited for worst-case. The Table E.1 shows the detail solution. It's satisfying the latest tissue dielectric parameters requirements proposed by the IEEE 1528 and IEC 62209.

Table E.1: Composition of the Tissue Equivalent Matter

Frequency (MHz)	835	1750	1900	2450	2600	5200	5800
Water	41.45	55.242	55.242	58.79	58.79	65.53	66.10
Sugar	56.0	/	/	/	/	/	/
Salt	1.45	0.306	0.306	0.06	0.06		
Preventol	0.1	/	/	/	/	17.24	16.95
Cellulose	1.0	/	/	/	/	17.24	16.95
Glycol Monobutyl	/	44.452	44.452	41.15	41.15	/	/
Diethylenglycol monohexylether	/	/	/	/	/	/	/
Triton X-100	/	/	/	/	/	/	/
Dielectric Parameters Target Value	$\epsilon=41.5$ $\sigma=0.90$	$\epsilon=40.08$ $\sigma=1.37$	$\epsilon=40.0$ $\sigma=1.40$	$\epsilon=39.20$ $\sigma=1.80$	$\epsilon=39.01$ $\sigma=1.96$	$\epsilon=35.99$ $\sigma=4.66$	$\epsilon=35.30$ $\sigma=5.27$

Note: There is a little adjustment respectively for 750, 5300 and 5600, based on the recipe of closest frequency in table E.1

ANNEX F: System Validation

The SAR system must be validated against its performance specifications before it is deployed. When SAR probes, system components or software are changed, upgraded or recalibrated, these must be validated with the SAR system(s) that operates with such components.

Table F.1: System Validation

Probe SN.	Liquid name (MHz)	Validation date	Frequency point	CW Validation	Modulation Signal Validation		
					Modulation Type	Duty Factor	PAR
7621	Head 750	2024-01-18	750MHz	Pass	N/A	N/A	N/A
7621	Head 835	2024-01-18	835MHz	Pass	GMSK	Pass	N/A
7621	Head 1750	2024-01-18	1750MHz	Pass	N/A	N/A	N/A
7621	Head 1900	2024-01-18	1900MHz	Pass	GMSK	Pass	N/A
7621	Head 2450	2024-01-20	2450MHz	Pass	OFDM/TDD	Pass	Pass
7621	Head 2550	2024-01-20	2550MHz	Pass	TDD	Pass	N/A
7621	Head 3500	2024-01-19	3500MHz	Pass	TDD	Pass	N/A
7621	Head 3700	2024-01-19	3700MHz	Pass	TDD	Pass	N/A
7621	Head 3900	2024-01-19	3900MHz	Pass	TDD	Pass	N/A
7621	Head 5250	2024-01-22	5250MHz	Pass	OFDM	N/A	Pass
7621	Head 5600	2024-01-22	5600MHz	Pass	OFDM	N/A	Pass
7621	Head 5750	2024-01-22	5750MHz	Pass	OFDM	N/A	Pass

ANNEX G: DAE Calibration Certificate

**Calibration Laboratory of
Schmid & Partner
Engineering AG**
Zeughausstrasse 43, 8004 Zurich, Switzerland





S Schweizerischer Kalibrierdienst
C Service suisse d'étalonnage
S Servizio svizzero di taratura
S Swiss Calibration Service

Accredited by the Swiss Accreditation Service (SAS)
The Swiss Accreditation Service is one of the signatories to the EA
Multilateral Agreement for the recognition of calibration certificates

Accreditation No.: **SCS 0108**

Client **SAICT**
Shenzhen

Certificate No: **DAE4-786_Dec23**

CALIBRATION CERTIFICATE			
Object	DAE4 - SD 000 D04 BM - SN: 786		
Calibration procedure(s)	QA CAL-06.v30 Calibration procedure for the data acquisition electronics (DAE)		
Calibration date:	December 11, 2023		
<p>This calibration certificate documents the traceability to national standards, which realize the physical units of measurements (SI). The measurements and the uncertainties with confidence probability are given on the following pages and are part of the certificate.</p> <p>All calibrations have been conducted in the closed laboratory facility: environment temperature (22 ± 3)°C and humidity < 70%.</p> <p>Calibration Equipment used (M&TE critical for calibration)</p>			
Primary Standards	ID #	Cal Date (Certificate No.)	Scheduled Calibration
Keithley Multimeter Type 2001	SN: 0810278	29-Aug-23 (No:37421)	Aug-24
Secondary Standards	ID #	Check Date (in house)	Scheduled Check
Auto DAE Calibration Unit	SE UWS 053 AA 1001	27-Jan-23 (in house check)	In house check: Jan-24
Calibrator Box V2.1	SE UMS 008 AA 1002	27-Jan-23 (in house check)	In house check: Jan-24
Calibrated by:	Name Dominique Steffen	Function Laboratory Technician	Signature 
Approved by:	Sven Kühn	Technical Manager	
			Issued: December 11, 2023
This calibration certificate shall not be reproduced except in full without written approval of the laboratory.			

Calibration Laboratory of
Schmid & Partner
Engineering AG
Zeughausstrasse 43, 8004 Zurich, Switzerland



S Schweizerischer Kalibrierdienst
S Service suisse d'étalonnage
C Servizio svizzero di taratura
S Swiss Calibration Service

Accredited by the Swiss Accreditation Service (SAS)
The Swiss Accreditation Service is one of the signatories to the EA
Multilateral Agreement for the recognition of calibration certificates

Accreditation No.: **SCS 0108**

Glossary

DAE data acquisition electronics
Connector angle information used in DASY system to align probe sensor X to the robot coordinate system.

Methods Applied and Interpretation of Parameters

- *DC Voltage Measurement*: Calibration Factor assessed for use in DASY system by comparison with a calibrated instrument traceable to national standards. The figure given corresponds to the full scale range of the voltmeter in the respective range.
- *Connector angle*: The angle of the connector is assessed measuring the angle mechanically by a tool inserted. Uncertainty is not required.
- The following parameters as documented in the Appendix contain technical information as a result from the performance test and require no uncertainty.
 - *DC Voltage Measurement Linearity*: Verification of the Linearity at +10% and -10% of the nominal calibration voltage. Influence of offset voltage is included in this measurement.
 - *Common mode sensitivity*: Influence of a positive or negative common mode voltage on the differential measurement.
 - *Channel separation*: Influence of a voltage on the neighbor channels not subject to an input voltage.
 - *AD Converter Values with inputs shorted*: Values on the internal AD converter corresponding to zero input voltage
 - *Input Offset Measurement*: Output voltage and statistical results over a large number of zero voltage measurements.
 - *Input Offset Current*: Typical value for information; Maximum channel input offset current, not considering the input resistance.
 - *Input resistance*: Typical value for information: DAE input resistance at the connector, during internal auto-zeroing and during measurement.
 - *Low Battery Alarm Voltage*: Typical value for information. Below this voltage, a battery alarm signal is generated.
 - *Power consumption*: Typical value for information. Supply currents in various operating modes.



DC Voltage Measurement

A/D - Converter Resolution nominal

High Range: 1LSB = 6.1 μ V , full range = -100...+300 mV

Low Range: 1LSB = 61nV , full range = -1.....+3mV

DASY measurement parameters: Auto Zero Time: 3 sec; Measuring time: 3 sec

Calibration Factors	X	Y	Z
High Range	404.093 \pm 0.02% (k=2)	404.226 \pm 0.02% (k=2)	404.638 \pm 0.02% (k=2)
Low Range	3.97228 \pm 1.50% (k=2)	3.94201 \pm 1.50% (k=2)	3.95929 \pm 1.50% (k=2)

Connector Angle

Connector Angle to be used in DASY system	331.0 $^{\circ}$ \pm 1 $^{\circ}$
---	-------------------------------------

Appendix (Additional assessments outside the scope of SCS0108)

1. DC Voltage Linearity

High Range	Reading (μV)	Difference (μV)	Error (%)
Channel X + Input	199986.65	1.02	0.00
Channel X + Input	19998.56	2.44	0.01
Channel X - Input	-20002.95	4.99	-0.02
Channel Y + Input	199984.14	-1.62	-0.00
Channel Y + Input	19995.50	-0.73	-0.00
Channel Y - Input	-20005.81	1.90	-0.01
Channel Z + Input	199983.31	-2.86	-0.00
Channel Z + Input	19996.62	0.41	0.00
Channel Z - Input	-20004.38	3.36	-0.02

Low Range	Reading (μV)	Difference (μV)	Error (%)
Channel X + Input	1995.80	0.72	0.04
Channel X + Input	196.27	0.94	0.48
Channel X - Input	-204.04	0.34	-0.17
Channel Y + Input	1995.03	-0.18	-0.01
Channel Y + Input	195.70	0.17	0.09
Channel Y - Input	-205.47	-1.22	0.60
Channel Z + Input	1995.18	-0.00	-0.00
Channel Z + Input	194.54	-0.97	-0.50
Channel Z - Input	-205.29	-1.05	0.51

2. Common mode sensitivity

DASY measurement parameters: Auto Zero Time: 3 sec; Measuring time: 3 sec

	Common mode Input Voltage (mV)	High Range Average Reading (μV)	Low Range Average Reading (μV)
Channel X	200	14.09	11.76
	-200	-10.45	-12.35
Channel Y	200	22.26	21.00
	-200	-22.82	-22.83
Channel Z	200	7.79	7.64
	-200	-9.85	-9.72

3. Channel separation

DASY measurement parameters: Auto Zero Time: 3 sec; Measuring time: 3 sec

	Input Voltage (mV)	Channel X (μV)	Channel Y (μV)	Channel Z (μV)
Channel X	200	-	-2.10	-3.21
Channel Y	200	9.93	-	-0.01
Channel Z	200	7.19	7.69	-

4. AD-Converter Values with inputs shorted

DASY measurement parameters: Auto Zero Time: 3 sec; Measuring time: 3 sec

	High Range (LSB)	Low Range (LSB)
Channel X	16083	14669
Channel Y	15939	15420
Channel Z	16116	13718

5. Input Offset Measurement

DASY measurement parameters: Auto Zero Time: 3 sec; Measuring time: 3 sec

Input 10M Ω

	Average (μ V)	min. Offset (μ V)	max. Offset (μ V)	Std. Deviation (μ V)
Channel X	0.87	-1.01	1.96	0.50
Channel Y	-0.17	-1.30	1.23	0.46
Channel Z	-0.13	-1.47	0.93	0.48

6. Input Offset Current

Nominal Input circuitry offset current on all channels: <25fA

7. Input Resistance (Typical values for information)

	Zeroing (kOhm)	Measuring (MOhm)
Channel X	200	200
Channel Y	200	200
Channel Z	200	200

8. Low Battery Alarm Voltage (Typical values for information)

Typical values	Alarm Level (VDC)
Supply (+ Vcc)	+7.9
Supply (- Vcc)	-7.6

9. Power Consumption (Typical values for information)

Typical values	Switched off (mA)	Stand by (mA)	Transmitting (mA)
Supply (+ Vcc)	+0.01	+6	+14
Supply (- Vcc)	-0.01	-8	-9



ANNEX H: Probe Calibration Certificate



Add: No.52 HuaYuanBei Road, Haidian District, Beijing, 100191, China
Tel: +86-10-62304633-2117
E-mail: emf@caict.ac.cn http://www.caict.ac.cn



Client **SAICT**

Certificate No: **J23Z60349**

CALIBRATION CERTIFICATE			
Object	EX3DV4 - SN : 7621		
Calibration Procedure(s)	FF-Z11-004-02 Calibration Procedures for Dosimetric E-field Probes		
Calibration date:	January 10, 2024		
This calibration Certificate documents the traceability to national standards, which realize the physical units of measurements(SI). The measurements and the uncertainties with confidence probability are given on the following pages and are part of the certificate.			
All calibrations have been conducted in the closed laboratory facility: environment temperature(22±3)°C and humidity<70%.			
Calibration Equipment used (M&TE critical for calibration)			
Primary Standards	ID #	Cal Date(Calibrated by, Certificate No.)	Scheduled Calibration
Power Meter NRP2	101919	12-Jun-23(CTTL, No.J23X05435)	Jun-24
Power sensor NRP-Z91	101547	12-Jun-23(CTTL, No.J23X05435)	Jun-24
Power sensor NRP-Z91	101548	12-Jun-23(CTTL, No.J23X05435)	Jun-24
Reference 10dBAttenuator	18N50W-10dB	19-Jan-23(CTTL, No.J23X00212)	Jan-25
Reference 20dBAttenuator	18N50W-20dB	19-Jan-23(CTTL, No.J23X00211)	Jan-25
Reference Probe EX3DV4	SN 3846	31-May-23(SPEAG, No.EX-3846_May23)	May-24
DAE4	SN 1555	24-Aug-23(SPEAG, No.DAE4-1555_Aug23)	Aug-24
Secondary Standards	ID #	Cal Date(Calibrated by, Certificate No.)	Scheduled Calibration
SignalGenerator MG3700A	6201052605	12-Jun-23(CTTL, No.J23X05434)	Jun-24
Network Analyzer E5071C	MY46110673	10-Jan-23(CTTL, No.J23X00104)	Jan-24
Reference 10dBAttenuator	BT0520	11-May-23(CTTL, No.J23X04061)	May-25
Reference 20dBAttenuator	BT0267	11-May-23(CTTL, No.J23X04062)	May-25
OCP DAK-12	SN 1174	25-Oct-23(SPEAG, No.OCP-DAK12-1174_Oct23)	Oct-24
	Name	Function	Signature
Calibrated by:	Yu Zongying	SAR Test Engineer	
Reviewed by:	Lin Jun	SAR Test Engineer	
Approved by:	Qi Dianyuan	SAR Project Leader	
Issued: January 16, 2024			
This calibration certificate shall not be reproduced except in full without written approval of the laboratory.			

Glossary:

TSL	tissue simulating liquid
NORM _{x,y,z}	sensitivity in free space
ConvF	sensitivity in TSL / NORM _{x,y,z}
DCP	diode compression point
CF	crest factor (1/duty_cycle) of the RF signal
A,B,C,D	modulation dependent linearization parameters
Polarization Φ	Φ rotation around probe axis
Polarization θ	θ rotation around an axis that is in the plane normal to probe axis (at measurement center), i $\theta=0$ is normal to probe axis

Connector Angle information used in DASY system to align probe sensor X to the robot coordinate system

Calibration is Performed According to the Following Standards:

- IEEE Std 1528-2013, "IEEE Recommended Practice for Determining the Peak Spatial-Averaged Specific Absorption Rate (SAR) in the Human Head from Wireless Communications Devices: Measurement Techniques", June 2013
- IEC 62209-1, "Measurement procedure for the assessment of Specific Absorption Rate (SAR) from hand-held and body-mounted devices used next to the ear (frequency range of 300 MHz to 6 GHz)", July 2016
- IEC 62209-2, "Procedure to determine the Specific Absorption Rate (SAR) for wireless communication devices used in close proximity to the human body (frequency range of 30 MHz to 6 GHz)", March 2010
- KDB 865664, "SAR Measurement Requirements for 100 MHz to 6 GHz"

Methods Applied and Interpretation of Parameters:

- NORM_{x,y,z}: Assessed for E-field polarization $\theta=0$ ($f \leq 900$ MHz in TEM-cell; $f > 1800$ MHz: waveguide). NORM_{x,y,z} are only intermediate values, i.e., the uncertainties of NORM_{x,y,z} does not effect the E^2 -field uncertainty inside TSL (see below ConvF).
- NORM(f)_{x,y,z} = NORM_{x,y,z} * frequency_response (see Frequency Response Chart). This linearization is implemented in DASY4 software versions later than 4.2. The uncertainty of the frequency response is included in the stated uncertainty of ConvF.
- DCP_{x,y,z}: DCP are numerical linearization parameters assessed based on the data of power sweep (no uncertainty required). DCP does not depend on frequency nor media.
- PAR: PAR is the Peak to Average Ratio that is not calibrated but determined based on the signal characteristics.
- A_{x,y,z}; B_{x,y,z}; C_{x,y,z}; VR_{x,y,z}: A,B,C are numerical linearization parameters assessed based on the data of power sweep for specific modulation signal. The parameters do not depend on frequency nor media. VR is the maximum calibration range expressed in RMS voltage across the diode.
- ConvF and Boundary Effect Parameters: Assessed in flat phantom using E-field (or Temperature Transfer Standard for $f \leq 800$ MHz) and inside waveguide using analytical field distributions based on power measurements for $f > 800$ MHz. The same setups are used for assessment of the parameters applied for boundary compensation (alpha, depth) of which typical uncertainty valued are given. These parameters are used in DASY4 software to improve probe accuracy close to the boundary. The sensitivity in TSL corresponds to NORM_{x,y,z} * ConvF whereby the uncertainty corresponds to that given for ConvF. A frequency dependent ConvF is used in DASY version 4.4 and higher which allows extending the validity from ± 50 MHz to ± 100 MHz.
- Spherical isotropy (3D deviation from isotropy): in a field of low gradients realized using a flat phantom exposed by a patch antenna.
- Sensor Offset: The sensor offset corresponds to the offset of virtual measurement center from the probe tip (on probe axis). No tolerance required.
- Connector Angle: The angle is assessed using the information gained by determining the NORM_x (no uncertainty required).

DASY/EASY – Parameters of Probe: EX3DV4 – SN: 7621

Basic Calibration Parameters

	Sensor X	Sensor Y	Sensor Z	Unc (k=2)
Norm($\mu\text{V}/(\text{V/m})^2$) ^A	0.75	0.69	0.56	±10.0%
DCP(mV) ^B	116.3	111.8	114.1	

Calibration Results for Modulation Response

UID	Communication System Name		A dB	B dB/μV	C	D dB	VR mV	Max Dev.	Max Unc ^E (k=2)
0	CW	X	0.0	0.0	1.0	0.00	245.0	±2.2%	±4.7%
		Y	0.0	0.0	1.0		228.9		
		Z	0.0	0.0	1.0		200.2		
10352-AAA	Pulse Waveform (200Hz, 10%)	X	1.58	60.00	5.98	10.00	60	±4.6%	±9.6%
		Y	1.66	60.00	6.30		60		
		Z	1.55	60.00	5.90		60		
10353-AAA	Pulse Waveform (200Hz, 20%)	X	1.00	60.00	4.70	6.99	80	±5.0%	±9.6%
		Y	1.16	60.00	5.35		80		
		Z	0.88	60.00	4.61		80		
10354-AAA	Pulse Waveform (200Hz, 40%)	X	0.56	60.00	3.40	3.98	95	±4.2%	±9.6%
		Y	0.72	60.00	4.43		95		
		Z	0.13	135.25	0.44		95		
10355-AAA	Pulse Waveform (200Hz, 60%)	X	15.06	149.56	3.00	2.22	120	±2.5%	±9.6%
		Y	19.78	144.48	5.80		120		
		Z	0.04	157.67	14.77		120		
10387-AAA	QPSK Waveform, 1 MHz	X	0.67	62.21	9.98	1.00	150	±4.8%	±9.6%
		Y	0.60	62.87	11.02		150		
		Z	0.60	62.46	10.17		150		
10388-AAA	QPSK Waveform, 10 MHz	X	1.35	64.07	12.55	0.00	150	±1.4%	±9.6%
		Y	1.43	65.73	13.69		150		
		Z	1.31	64.32	12.60		150		
10396-AAA	64-QAM Waveform, 100 kHz	X	2.08	68.01	18.04	3.01	150	±1.0%	±9.6%
		Y	1.90	66.41	17.71		150		
		Z	2.09	68.06	18.19		150		
10414-AAA	WLAN CCDF, 64-QAM, 40MHz	X	4.04	65.58	14.84	0.00	150	±5.2%	±9.6%
		Y	4.02	66.13	15.30		150		
		Z	3.92	65.71	14.88		150		

Note: For details on UID parameters see Appendix

The reported uncertainty of measurement is stated as the standard uncertainty of Measurement multiplied by the coverage factor $k=2$, which for a normal distribution Corresponds to a coverage probability of approximately 95%.

^A The uncertainties of Norm X, Y, Z do not affect the E²-field uncertainty inside TSL (see Page 5).

^B Numerical linearization parameter: uncertainty not required.

^E Uncertainty is determined using the max. deviation from linear response applying rectangular distribution and is expressed for the square of the field value.

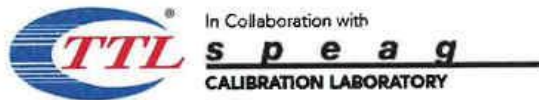

Add: No.52 HuaYuanBei Road, Haidian District, Beijing, 100191, China
Tel: +86-10-62304633-2117
E-mail: emf@caict.ac.cn http://www.caict.ac.cn

DASY/EASY – Parameters of Probe: EX3DV4 – SN: 7621

Sensor Model Parameters

	C1 fF	C2 fF	α V ⁻¹	T1 ms.V ⁻²	T2 ms.V ⁻¹	T3 ms	T4 V ⁻²	T5 V ⁻¹	T6
X	15.06	105.97	31.62	5.46	0.00	4.90	0.72	0.00	1.02
Y	12.33	88.55	32.92	13.24	0.00	4.90	0.18	0.05	1.02
Z	12.49	87.81	31.63	2.66	0.00	4.90	0.76	0.00	1.02

Other Probe Parameters

Sensor Arrangement	Triangular
Connector Angle (°)	136
Mechanical Surface Detection Mode	enabled
Optical Surface Detection Mode	disable
Probe Overall Length	337mm
Probe Body Diameter	10mm
Tip Length	9mm
Tip Diameter	2.5mm
Probe Tip to Sensor X Calibration Point	1mm
Probe Tip to Sensor Y Calibration Point	1mm
Probe Tip to Sensor Z Calibration Point	1mm
Recommended Measurement Distance from Surface	1.4mm

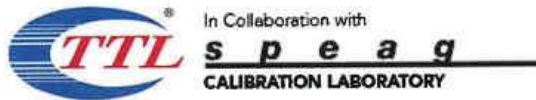

Add: No.52 HuaYuanBei Road, Haidian District, Beijing, 100191, China
 Tel: +86-10-62304633-2117
 E-mail: emf@caict.ac.cn <http://www.caict.ac.cn>

DASY/EASY – Parameters of Probe: EX3DV4 – SN:7621

Calibration Parameter Determined in Head Tissue Simulating Media

f [MHz] ^C	Relative Permittivity ^F	Conductivity (S/m) ^F	ConvF X	ConvF Y	ConvF Z	Alpha ^G	Depth ^G (mm)	Unct. (k=2)
750	41.9	0.89	11.02	11.02	11.02	0.14	1.34	±12.7%
900	41.5	0.97	10.53	10.53	10.53	0.16	1.38	±12.7%
1750	40.1	1.37	9.11	9.11	9.11	0.24	0.99	±12.7%
1900	40.0	1.40	8.76	8.76	8.76	0.28	0.95	±12.7%
2100	39.8	1.49	8.72	8.72	8.72	0.26	1.01	±12.7%
2300	39.5	1.67	8.50	8.50	8.50	0.65	0.68	±12.7%
2450	39.2	1.80	8.21	8.21	8.21	0.67	0.67	±12.7%
2600	39.0	1.96	8.02	8.02	8.02	0.65	0.68	±12.7%
3300	38.2	2.71	7.70	7.70	7.70	0.43	0.95	±13.9%
3500	37.9	2.91	7.52	7.52	7.52	0.41	1.00	±13.9%
3700	37.7	3.12	7.31	7.31	7.31	0.43	1.04	±13.9%
3900	37.5	3.32	7.09	7.09	7.09	0.35	1.50	±13.9%
4100	37.2	3.53	7.10	7.10	7.10	0.40	1.15	±13.9%
5250	35.9	4.71	5.95	5.95	5.95	0.45	1.40	±13.9%
5600	35.5	5.07	5.25	5.25	5.25	0.50	1.35	±13.9%
5800	35.3	5.27	5.33	5.33	5.33	0.55	1.25	±13.9%

^C Frequency validity above 300 MHz of ±100MHz only applies for DASY v4.4 and higher (Page 2), else it is restricted to ±50MHz. The uncertainty is the RSS of ConvF uncertainty at calibration frequency and the uncertainty for the indicated frequency band. Frequency validity below 300 MHz is ± 10, 25, 40, 50 and 70 MHz for ConvF assessments at 30, 64, 128, 150 and 220 MHz respectively. Above 5 GHz frequency validity can be extended to ± 110 MHz.

^F At frequency up to 6 GHz, the validity of tissue parameters (ϵ and σ) can be relaxed to ±10% if liquid compensation formula is applied to measured SAR values. The uncertainty is the RSS of the ConvF uncertainty for indicated target tissue parameters.

^G Alpha/Depth are determined during calibration. SPEAG warrants that the remaining deviation due to the boundary effect after compensation is always less than ± 1% for frequencies below 3 GHz and below ± 2% for the frequencies between 3-6 GHz at any distance larger than half the probe tip diameter from the boundary.

Frequency Response of E-Field (TEM-Cell: ifi110 EXX, Waveguide: R22)

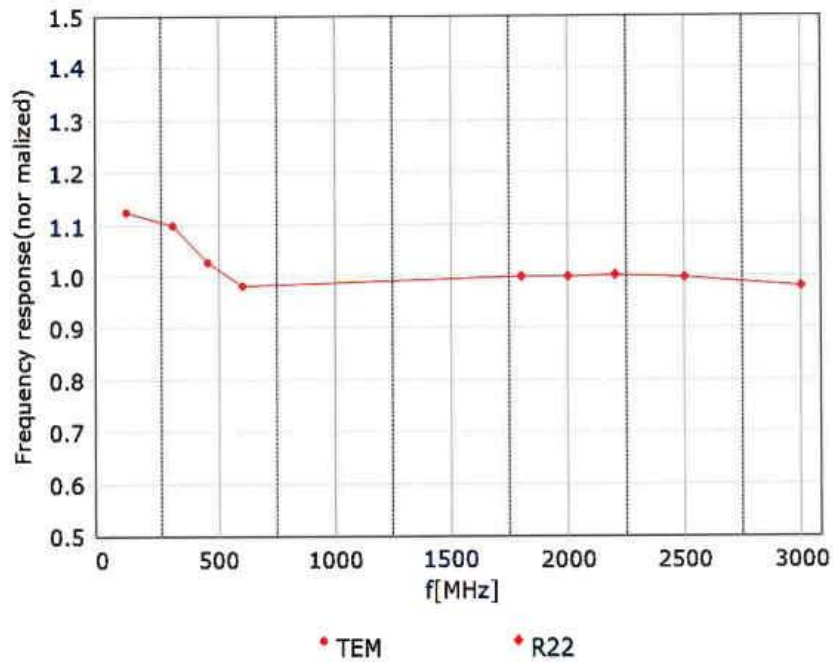

Uncertainty of Frequency Response of E-field: $\pm 7.4\%$ ($k=2$)

Receiving Pattern (Φ), $\theta=0^\circ$

f=600 MHz, TEM

f=1800 MHz, R22

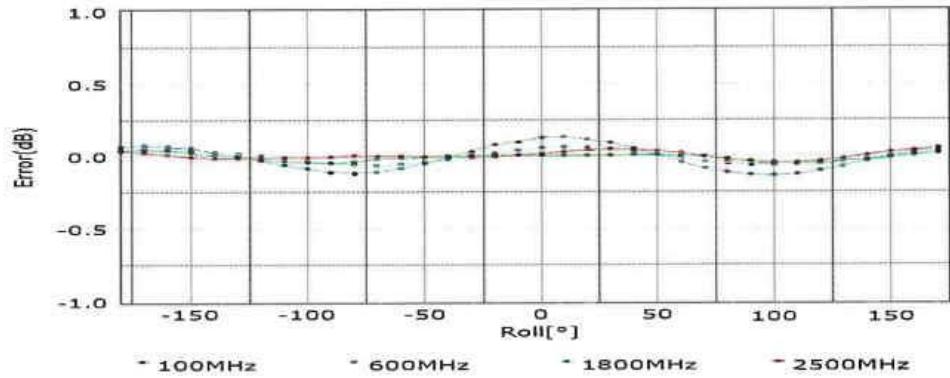
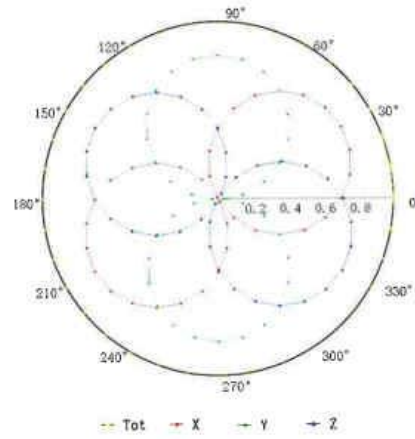
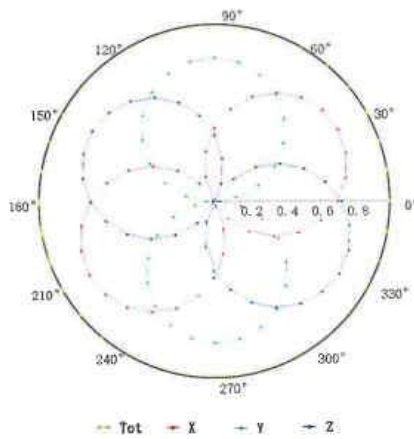

Uncertainty of Axial Isotropy Assessment: $\pm 1.2\%$ ($k=2$)

Dynamic Range f(SAR_{head}) (TEM cell, f = 900 MHz)

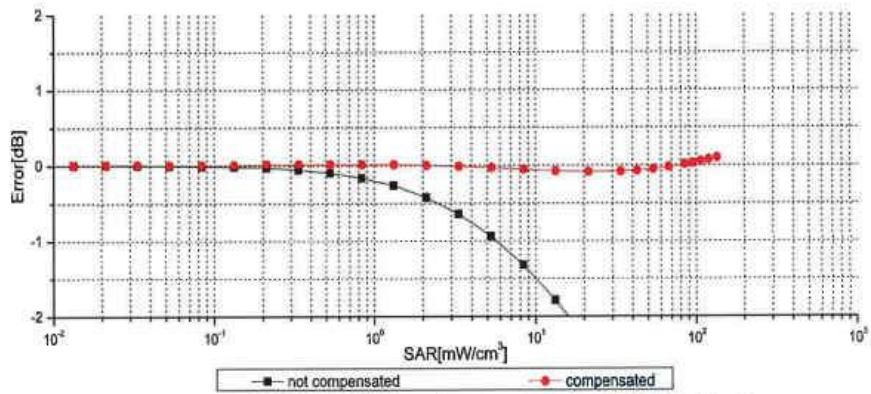
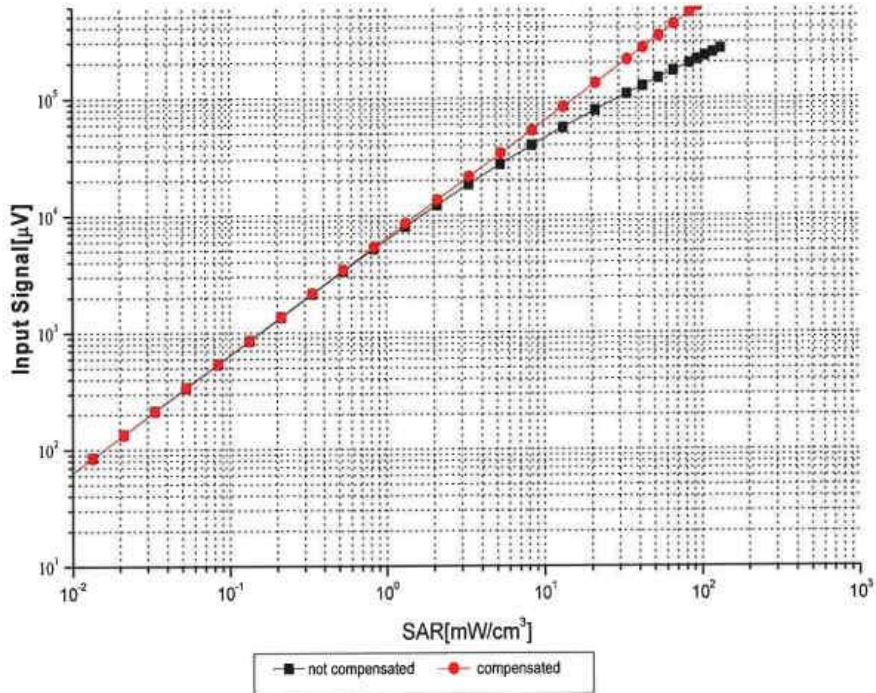

Uncertainty of Linearity Assessment: ±0.9% (k=2)

Conversion Factor Assessment

f=750 MHz,WGLS R9(H_convF)

f=1750 MHz,WGLS R22(H_convF)

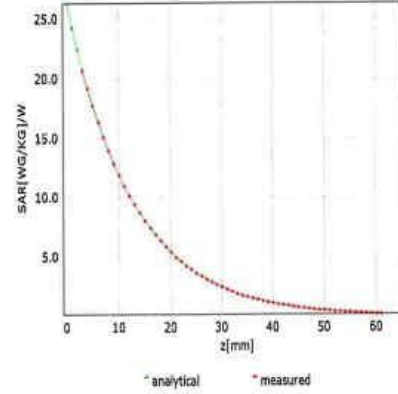
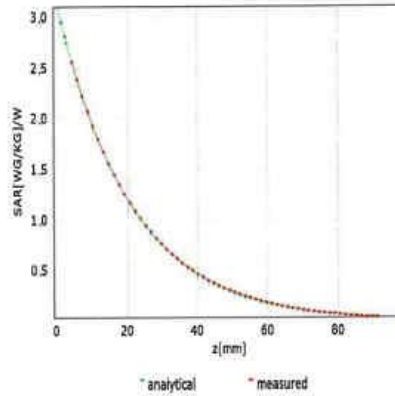

Deviation from Isotropy in Liquid

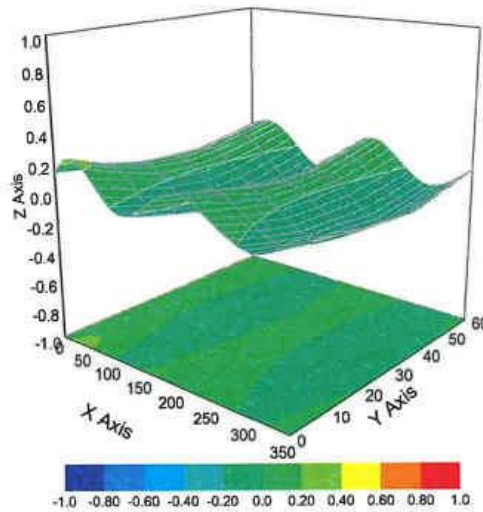

Uncertainty of Spherical Isotropy Assessment: $\pm 3.2\%$ ($k=2$)

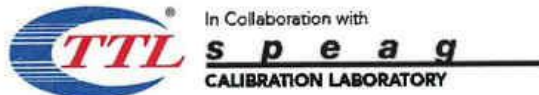

Add: No.52 HuaYuanBei Road, Haidian District, Beijing, 100191, China
 Tel: +86-10-62304633-2117
 E-mail: emf@caict.ac.cn http://www.caict.ac.cn

Appendix: Modulation Calibration Parameters

UID	Rev	Communication System Name	Group	PAR (dB)	UncE (k=2)
0		CW	CW	0.00	± 4.7 %
10010	CAA	SAR Validation (Square, 100ms, 10ms)	Test	10.00	± 9.6 %
10011	CAB	UMTS-FDD (WCDMA)	WCDMA	2.91	± 9.6 %
10012	CAB	IEEE 802.11b WiFi 2.4 GHz (DSSS, 1 Mbps)	WLAN	1.87	± 9.6 %
10013	CAB	IEEE 802.11g WiFi 2.4 GHz (DSSS-OFDM, 6 Mbps)	WLAN	9.46	± 9.6 %
10021	DAC	GSM-FDD (TDMA, GMSK)	GSM	9.39	± 9.6 %
10023	DAC	GPRS-FDD (TDMA, GMSK, TN 0)	GSM	9.57	± 9.6 %
10024	DAC	GPRS-FDD (TDMA, GMSK, TN 0-1)	GSM	6.56	± 9.6 %
10025	DAC	EDGE-FDD (TDMA, 8PSK, TN 0)	GSM	12.62	± 9.6 %
10026	DAC	EDGE-FDD (TDMA, 8PSK, TN 0-1)	GSM	9.55	± 9.6 %
10027	DAC	GPRS-FDD (TDMA, GMSK, TN 0-1-2)	GSM	4.80	± 9.6 %
10028	DAC	GPRS-FDD (TDMA, GMSK, TN 0-1-2-3)	GSM	3.55	± 9.6 %
10029	DAC	EDGE-FDD (TDMA, 8PSK, TN 0-1-2)	GSM	7.78	± 9.6 %
10030	CAA	IEEE 802.15.1 Bluetooth (GFSK, DH1)	Bluetooth	5.30	± 9.6 %
10031	CAA	IEEE 802.15.1 Bluetooth (GFSK, DH3)	Bluetooth	1.87	± 9.6 %
10032	CAA	IEEE 802.15.1 Bluetooth (GFSK, DH5)	Bluetooth	1.16	± 9.6 %
10033	CAA	IEEE 802.15.1 Bluetooth (PI/4-DQPSK, DH1)	Bluetooth	7.74	± 9.6 %
10034	CAA	IEEE 802.15.1 Bluetooth (PI/4-DQPSK, DH3)	Bluetooth	4.53	± 9.6 %
10035	CAA	IEEE 802.15.1 Bluetooth (PI/4-DQPSK, DH5)	Bluetooth	3.83	± 9.6 %
10036	CAA	IEEE 802.15.1 Bluetooth (8-DPSK, DH1)	Bluetooth	8.01	± 9.6 %
10037	CAA	IEEE 802.15.1 Bluetooth (8-DPSK, DH3)	Bluetooth	4.77	± 9.6 %
10038	CAA	IEEE 802.15.1 Bluetooth (8-DPSK, DH5)	Bluetooth	4.10	± 9.6 %
10039	CAB	CDMA2000 (1xRTT, RC1)	CDMA2000	4.57	± 9.6 %
10042	CAB	IS-54 / IS-136 FDD (TDMA/FDM, PI/4-DQPSK, Halfrate)	AMPS	7.78	± 9.6 %
10044	CAA	IS-91/EIA/TIA-553 FDD (FDMA, FM)	AMPS	0.00	± 9.6 %
10048	CAA	DECT (TDD, TDMA/FDM, GFSK, Full Slot, 24)	DECT	13.80	± 9.6 %
10049	CAA	DECT (TDD, TDMA/FDM, GFSK, Double Slot, 12)	DECT	10.79	± 9.6 %
10056	CAA	UMTS-TDD (TD-SCDMA, 1.28 Mcps)	TD-SCDMA	11.01	± 9.6 %
10058	DAC	EDGE-FDD (TDMA, 8PSK, TN 0-1-2-3)	GSM	6.52	± 9.6 %
10059	CAB	IEEE 802.11b WiFi 2.4 GHz (DSSS, 2 Mbps)	WLAN	2.12	± 9.6 %
10060	CAB	IEEE 802.11b WiFi 2.4 GHz (DSSS, 5.5 Mbps)	WLAN	2.83	± 9.6 %
10061	CAB	IEEE 802.11b WiFi 2.4 GHz (DSSS, 11 Mbps)	WLAN	3.60	± 9.6 %
10062	CAD	IEEE 802.11a/h WiFi 5 GHz (OFDM, 6 Mbps)	WLAN	8.68	± 9.6 %
10063	CAD	IEEE 802.11a/h WiFi 5 GHz (OFDM, 9 Mbps)	WLAN	8.63	± 9.6 %
10064	CAD	IEEE 802.11a/h WiFi 5 GHz (OFDM, 12 Mbps)	WLAN	9.09	± 9.6 %
10065	CAD	IEEE 802.11a/h WiFi 5 GHz (OFDM, 18 Mbps)	WLAN	9.00	± 9.6 %
10066	CAD	IEEE 802.11a/h WiFi 5 GHz (OFDM, 24 Mbps)	WLAN	9.38	± 9.6 %
10067	CAD	IEEE 802.11a/h WiFi 5 GHz (OFDM, 36 Mbps)	WLAN	10.12	± 9.6 %
10068	CAD	IEEE 802.11a/h WiFi 5 GHz (OFDM, 48 Mbps)	WLAN	10.24	± 9.6 %
10069	CAD	IEEE 802.11a/h WiFi 5 GHz (OFDM, 54 Mbps)	WLAN	10.56	± 9.6 %
10071	CAB	IEEE 802.11g WiFi 2.4 GHz (DSSS/OFDM, 9 Mbps)	WLAN	9.83	± 9.6 %
10072	CAB	IEEE 802.11g WiFi 2.4 GHz (DSSS/OFDM, 12 Mbps)	WLAN	9.62	± 9.6 %
10073	CAB	IEEE 802.11g WiFi 2.4 GHz (DSSS/OFDM, 18 Mbps)	WLAN	9.94	± 9.6 %
10074	CAB	IEEE 802.11g WiFi 2.4 GHz (DSSS/OFDM, 24 Mbps)	WLAN	10.30	± 9.6 %
10075	CAB	IEEE 802.11g WiFi 2.4 GHz (DSSS/OFDM, 36 Mbps)	WLAN	10.77	± 9.6 %
10076	CAB	IEEE 802.11g WiFi 2.4 GHz (DSSS/OFDM, 48 Mbps)	WLAN	10.94	± 9.6 %
10077	CAB	IEEE 802.11g WiFi 2.4 GHz (DSSS/OFDM, 54 Mbps)	WLAN	11.00	± 9.6 %
10081	CAB	CDMA2000 (1xRTT, RC3)	CDMA2000	3.97	± 9.6 %
10082	CAB	IS-54 / IS-136 FDD (TDMA/FDM, PI/4-DQPSK, Fullrate)	AMPS	4.77	± 9.6 %
10090	DAC	GPRS-FDD (TDMA, GMSK, TN 0-4)	GSM	6.56	± 9.6 %
10097	CAC	UMTS-FDD (HSDPA)	WCDMA	3.98	± 9.6 %
10098	DAC	UMTS-FDD (HSUPA, Subtest 2)	WCDMA	3.98	± 9.6 %
10099	CAC	EDGE-FDD (TDMA, 8PSK, TN 0-4)	GSM	9.55	± 9.6 %
10100	CAC	LTE-FDD (SC-FDMA, 100% RB, 20 MHz, QPSK)	LTE-FDD	5.67	± 9.6 %
10101	CAB	LTE-FDD (SC-FDMA, 100% RB, 20 MHz, 16-QAM)	LTE-FDD	6.42	± 9.6 %

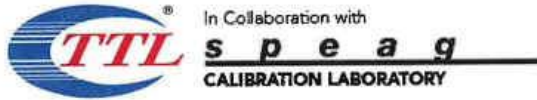

Add: No.52 HuaYuanBei Road, Haidian District, Beijing, 100191, China
Tel: +86-10-62304633-2117
E-mail: emf@caict.ac.cn http://www.caict.ac.cn

Table with 6 columns: ID, Model, Modem, Modem, Reference, and Accuracy. It lists various calibration items for LTE-FDD, LTE-TDD, and WLAN, including parameters like RB, MHz, and QAM. All accuracy values are ± 9.6%.



Add: No.52 HuaYuanBei Road, Haidian District, Beijing, 100191, China
Tel: +86-10-62304633-2117
E-mail: emf@caict.ac.cn http://www.caict.ac.cn

Table with 6 columns: ID, Code, Modem, Modem Type, Modem Type, Value, and Error. Rows include various LTE and UMTS test configurations like LTE-FDD, LTE-TDD, and UMTS-FDD with their respective parameters and test results.



Add: No.52 HuaYuanBei Road, Haidian District, Beijing, 100191, China
Tel: +86-10-62304633-2117
E-mail: cmf@caict.ac.cn http://www.caict.ac.cn

Table with 6 columns: ID, Standard, Test Method, Equipment, Result, and Error. Rows include various standards like LTE-TDD, UMTS-FDD, CDMA2000, IEEE 802.11, and WLAN CDF.