



Test Report No.: PSU-NQN2403180115RF05



FCC TEST REPORT (PART 22)

Applicant:	HMD Global Oy
Address:	Bertel Jungin aukio 9,02600 Espoo, Finland

Manufacturer or Supplier:	HMD Global Oy
Address:	Bertel Jungin aukio 9,02600 Espoo, Finland
Product:	Smart phone
Brand Name:	HMD
Model Name:	TA-1600/TA-1688
FCC ID:	2AJOTTA-1600
Date of tests:	Apr. 08, 2024 ~ May. 31, 2024

The tests have been carried out according to the requirements of the following standard:

- FCC PART 22, Subpart H FCC Part 2
- ANSI/TIA/EIA-603-D ANSI C63.26-2015
- ANSI/TIA/EIA-603-E

CONCLUSION: The submitted sample was found to COMPLY with the test requirement

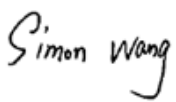
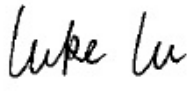
Prepared by Simon Wang Engineer / Mobile Department	Approved by Luke Lu Manager / Mobile Department
 Date: May. 31, 2024	 Date: May. 31, 2024

This report is governed by, and incorporates by reference, the Conditions of Testing as posted at the date of issuance of this report at <http://www.bureauveritas.com/home/about-us/our-business/cps/about-us/terms-conditions/> and is intended for your exclusive use. Any copying or replication of this report to or for any other person or entity, or use of our name or trademark, is permitted only with our prior written permission. This report sets forth our findings solely with respect to the test samples identified herein. The results set forth in this report are not indicative or representative of the quality or characteristics of the lot from which a test sample was taken or any similar or identical product unless specifically and expressly noted. Our report includes all of the tests requested by you and the results thereof based upon the information that you provided to us. Measurement uncertainty is only provided upon request for accredited tests. Statements of conformity are based on simple acceptance criteria without taking measurement uncertainty into account, unless otherwise requested in writing. You have 60 days from date of issuance of this report to notify us of any material error or omission caused by our negligence or if you require measurement uncertainty; provided, however, that such notice shall be in writing and shall specifically address the issue you wish to raise. A failure to raise such issue within the prescribed time shall constitute your unqualified acceptance of the completeness of this report, the tests conducted and the correctness of the report contents.



TABLE OF CONTENTS

RELEASE CONTROL RECORD4

1 SUMMARY OF TEST RESULTS5

1.1 MEASUREMENT UNCERTAINTY6

1.2 TEST SITE AND INSTRUMENTS7

2 GENERAL INFORMATION10

2.1 GENERAL DESCRIPTION OF EUT10

2.2 CONFIGURATION OF SYSTEM UNDER TEST14

2.3 DESCRIPTION OF SUPPORT UNITS15

2.4 TEST ITEM AND TEST CONFIGURATION15

2.5 EUT OPERATING CONDITIONS19

2.6 GENERAL DESCRIPTION OF APPLIED STANDARDS20

3 TEST TYPES AND RESULTS21

3.1 OUTPUT POWER MEASUREMENT21

3.1.1 LIMITS OF OUTPUT POWER MEASUREMENT21

3.1.2 TEST PROCEDURES21

3.1.3 TEST SETUP22

3.1.4 TEST RESULTS22

3.2 FREQUENCY STABILITY MEASUREMENT42

3.2.1 LIMITS OF FREQUENCY STABILITY MEASUREMENT42

3.2.2 TEST PROCEDURE42

3.2.3 TEST SETUP42

3.2.4 TEST RESULTS43

3.3 OCCUPIED BANDWIDTH MEASUREMENT44

3.3.1 LIMITS OF OCCUPIED BANDWIDTH MEASUREMENT44

3.3.2 TEST SETUP44

3.3.3 TEST PROCEDURES44

3.3.4 TEST RESULTS45

3.4 BAND EDGE MEASUREMENT46

3.4.1 LIMITS OF BAND EDGE MEASUREMENT46

3.4.2 TEST SETUP46

3.4.3 TEST PROCEDURES47

3.4.4 TEST RESULTS48

3.5 CONDUCTED SPURIOUS EMISSIONS49

3.5.1 LIMITS OF CONDUCTED SPURIOUS EMISSIONS MEASUREMENT49

3.5.2 TEST PROCEDURE49

3.5.3 TEST SETUP49

3.5.4 TEST RESULTS50

3.6 RADIATED EMISSION MEASUREMENT51

3.6.1 LIMITS OF RADIATED EMISSION MEASUREMENT51

3.6.2 TEST PROCEDURES51

3.6.3 DEVIATION FROM TEST STANDARD51

3.6.4 TEST SETUP52



Test Report No.: PSU-NQN2403180115RF05

3.6.5	TEST RESULTS	54
3.7	PEAK TO AVERAGE RATIO	100
3.7.1	LIMITS OF PEAK TO AVERAGE RATIO MEASUREMENT	100
3.7.2	TEST SETUP	100
3.7.3	TEST PROCEDURES	100
3.7.4	TEST RESULTS	101
4	PHOTOGRAPHS OF THE TEST CONFIGURATION	102
5	INFORMATION ON THE TESTING LABORATORIES	103
6	MODIFICATIONS RECORDERS FOR ENGINEERING CHANGES TO THE EUT BY THE LAB	104



BUREAU
VERITAS

Test Report No.: PSU-NQN2403180115RF05

RELEASE CONTROL RECORD

ISSUE NO.	REASON FOR CHANGE	DATE ISSUED
PSU-NQN2403180115RF05	Original release	May. 31, 2024



1 SUMMARY OF TEST RESULTS

The EUT has been tested according to the following specifications:

APPLIED STANDARD: FCC Part 22 & Part 2			
STANDARD SECTION	TEST TYPE	RESULT	Test lab*
§2.1046	Conducted Output Power	Compliance	B
§22.913 (a)(5) §22.913(a)(2)	Effective Radiated Power	Compliance	B
§2.1055 §22.355	Frequency Stability	Compliance	A
§2.1049 §22.917(b)	Occupied Bandwidth	Compliance	A
§22.913 (d)	Peak to average ratio*	Compliance	A
§22.917(a)	Band Edge Measurements	Compliance	A
§2.1051 §22.917(a)	Conducted Spurious Emissions	Compliance	A
§2.1053 §22.917(a)	Radiated Spurious Emissions	Compliance	B

* Refer to KDB 971168 D01 Power Meas License Digital Systems v03r01.

*Test Lab Information Reference

Lab A:

BV 7Layers Communications Technology (Shenzhen) Co. Ltd

Lab Address:

Room B37, Warehouse A5, No.3 Chiwan 4th Road, Zhaoshang Street, Nanshan District
Shenzhen, Guangdong, People’s Republic of China

Accredited Test Lab Cert 3939.01

The FCC Site Registration No. is 525120; The Designation No. is CN1171.

Lab B:

Huarui 7Layers High Technology (Suzhou) Co., Ltd.

Lab Address:

Tower N, Innovation Center, 88 Zhuyi Road, High-tech District, Suzhou City, Anhui Province

Accredited Test Lab Cert 6613.01

The FCC Site Registration No. is 434559; The Designation No. is CN1325.



1.1 MEASUREMENT UNCERTAINTY

Where relevant, the following measurement uncertainty levels have been estimated for tests performed on the EUT as specified in CISPR 16-4-2:

MEASUREMENT	UNCERTAINTY
Maximum Peak Output Power	±2.06dB
Frequency Stability	±76.97Hz
Radiated emissions (9KHz~30MHz)	±2.68dB
Radiated emissions (30MHz~1GHz)	±4.98dB
Radiated emissions (1GHz ~6GHz)	±4.70dB
Radiated emissions (6GHz ~18GHz)	±4.60dB
Radiated emissions (18GHz ~40GHz)	±4.12dB
Conducted emissions	±4.01dB
Occupied Channel Bandwidth	±43.58KHz
Band Edge Measurements	±4.70dB
Peak to average ratio	±0.76dB

This uncertainty represents an expanded uncertainty expressed at approximately the 95% confidence level using a coverage factor of k=2.



1.2 TEST SITE AND INSTRUMENTS

Equipment	Manufacturer	Model No.	Serial No.	Last Cal.	Next Cal.
MXE EMI Receiver	KEYSIGHT	N9038A-544	MY54450026	Mar. 28,23	Mar. 27,24
MXE EMI Receiver	KEYSIGHT	N9038A-544	MY54450026	Mar. 27,24	Mar. 26,25
EXA Signal Analyzer	KEYSIGHT	N9010A-544	MY54510355	May. 10,23	May. 09,24
EXA Signal Analyzer	KEYSIGHT	N9010A-544	MY54510355	May. 09,24	May. 08,25
Loop Antenna	Schwarzbeck	FMZB 1519B	00173	Sep. 02,23	Sep. 01,24
Bilog Antenna	ETS-LINDGRE N	3143B	00161965	Feb. 17,24	Feb. 16,25
Horn Antenna	ETS-LINDGRE N	3117	00168692	Feb. 17,24	Feb. 16,25
Horn Antenna (18GHz-40GHz)	N/A	QWH-SL-18-40-K- SG/QMS-00361	15433	Sep. 03,23	Sep. 03,24
Radio Communication Analyzer	ANRITSU	MT8820C	6201465426	Feb. 13,24	Feb. 12,25
Signal Pre-Amplifier	EMSI	EMC 9135	980249	May. 06,23	May. 05,24
Signal Pre-Amplifier	EMSI	EMC 9135	980249	May. 05,24	May. 04,25
Signal Pre-Amplifier	EMSI	EMC 012645B	980257	May. 10,23	May.09,24
Signal Pre-Amplifier	EMSI	EMC 012645B	980257	May. 09,24	May.08,25
Signal Pre-Amplifier	EMSI	EMC 184045B	980259	Feb. 16,24	Feb. 15,25
3m Semi-anechoic Chamber	ETS-LINDGRE N	9m*6m*6m	Euroshieldpn- CT0001143-121 6	Nov. 14,23	Nov. 13,26
Test Software	E3	V 9.160323	N/A	N/A	N/A
Test Software	JS1120	3.1.36	N/A	N/A	N/A
10dB Attenuator	JFW/USA	50HF-010-SMA	50HF-010-SMA	May. 06,23	May. 05,24
10dB Attenuator	JFW/USA	50HF-010-SMA	50HF-010-SMA	May. 05,24	May. 04,25
Power Meter	Anritsu	ML2495A	1506002	Feb. 13,24	Feb. 12,25
Power Sensor	Anritsu	MA2411B	1339352	Feb. 13,24	Feb. 12,25
Temperature Chamber	ESPEC	SH-242	93000855	May. 06,23	May. 05,24
Temperature Chamber	ESPEC	SH-242	93000855	May. 05,24	May. 04,25
MXG Analog Microvave Signal Generator	KEYSIGHT	N5183A	MY50143024	Feb. 13,24	Feb. 12,25
Base station R&S CMW500	Rohde&Schwa rz	CMW500	153085	May.10,23	May.09,24
Base station R&S CMW500	Rohde&Schwa rz	CMW500	153085	May. 09,24	May.08,25
DC Source	Kikusui/JP	PMX18-5A	N/A	Aug. 11,23	Aug. 10,24

- NOTE:**
1. The calibration interval of the above test instruments is 12 months or 36 months and the calibrations are traceable to CEPREI/CHINA, GRGT/CHINA and NIM/CHINA.
 2. The test was performed in 3m Semi-anechoic Chamber and RF Oven Room.
 3. The horn antenna is used only for the measurement of emission frequency above 1GHz if tested.
 4. The FCC Site Registration No. is 525120; The Designation No. is CN1171.



Equipment	Manufacturer	Model No.	Serial No.	Last Cal.	Next Cal.
Pre-Amplifier	R&S	SCU18F1	100815	Aug.30,22	Aug.29,24
Pre-Amplifier	R&S	SCU08F1	101028	Sep.16,22	Sep.15,24
Vector Signal Generator	R&S	SMBV100B	102176	Feb.15,24	Feb.14,26
Signal Generator	R&S	SMB100A	182185	Feb.15,24	Feb.14,26
3m Fully-anechoic Chamber	TDK	9m*6m*6m	HRSW-SZ-E MC-01 Chamber	Nov.25,22	Nov.24,25
3m Semi-anechoic Chamber	TDK	9m*6m*6m	HRSW-SZ-E MC-02 Chamber	Nov.25,22	Nov.24,25
EMI TEST Receiver	R&S	ESR26	101734	Feb.24,24	Feb.23,26
EMI TEST Receiver	R&S	ESW44	101973	Feb.24,24	Feb.23,26
Bilog Antenna	SCHWARZBECK	VULB 9163	1264	Feb.27,24	Feb.26,26
Horn Antenna	ETS-LINDGREN	3117	227836	Aug.22,22	Aug.21,24
Horn Antenna (18GHZ-40GHZ)	Steatite Q-par Antennas	QMS 00880	23486	Feb.22,24	Feb.21,26
Horn Antenna	Steatite Q-par Antennas	QMS 00208	23485	Aug.22,22	Aug.21,24
Loop Antenna	SCHWARZ	HFH2-Z2/Z2E	100976	Feb.22,24	Feb.21,26
WIDEBANDRADIO COMMUNICATION TESTER	R&S	CMW500	169399	Jun.27,22	Jun.26,24
Test Software	EMC32	EMC32	N/A	N/A	N/A
Test Software	ELEKTRA	ELEKTRA4.32	N/A	N/A	N/A
Open Switch and Control Unit	R&S	OSP220	101964	Oct.01,22	Sep.30,24
DC Source	HYELEC	HY3010B	551016	Aug.31,22	Aug.30,24
Hygrothermograph	DELI	20210528	SZ014	Sep.06,22	Sep.05,24
PC	LENOVO	E14	HRSW0024	N/A	N/A
TMC-AMI18843A(CABLE)	R&S	HF290-NMNM-7.00M	N/A	N/A	N/A
TMC-AMI18843A(CABLE)	R&S	HF290-NMNM-4.00M	N/A	N/A	N/A
CABLE	R&S	W13.02	N/A	Apr.28,23	Apr.27,24
CABLE	R&S	W13.02	N/A	Apr.27,24	Apr.26,25
CABLE	R&S	W12.14	N/A	Apr.28,23	Apr.27,24
CABLE	R&S	W12.14	N/A	Apr.27,24	Apr.26,25
CABLE	R&S	J12J103539-00-1	SEP-03-20-069	Apr.28,23	Apr.27,24
CABLE	R&S	J12J103539-00-1	SEP-03-20-069	Apr.27,24	Apr.26,25
CABLE	R&S	J12J103539-00-1	SEP-03-20-070	Apr.28,23	Apr.27,24
CABLE	R&S	J12J103539-00-1	SEP-03-20-070	Apr.27,24	Apr.26,25
Temperature Chamber	votsch	VT4002	58566078100050	May.31,22	May.30,24



**BUREAU
VERITAS**

Test Report No.: PSU-NQN2403180115RF05

Temperature Chamber	votsch	VT4002	5856607810 0050	May.30,24	May.29,26
---------------------	--------	--------	--------------------	-----------	-----------

- NOTE:**
1. The calibration interval of the above test instruments is 12/ 24 / 36 months and the calibrations are traceable to CEPREI/CHINA, GRGT/CHINA and NIM/CHINA.
 2. The test was performed in 3m Semi-anechoic Chamber and RF Oven Room.
 3. The horn antenna is used only for the measurement of emission frequency above 1GHz if tested.
 4. The FCC Site Registration No. is 434559; The Designation No. is CN1325.



2 GENERAL INFORMATION

2.1 GENERAL DESCRIPTION OF EUT

PRODUCT	Smart phone	
BRAND NAME	HMD	
MODEL NAME	TA-1600/TA-1688	
NOMINAL VOLTAGE	5.0Vdc/9.0Vdc /12.0Vdc(adapter) 3.89Vdc (battery)	
MODULATION TYPE	GSM/EDGE	GMSK, 8PSK
	WCDMA	BPSK, QPSK
	LTE	QPSK, 16QAM, 64QAM
	LTE CA	CA_2A-5A/ CA_4A-5A
FREQUENCY RANGE	GSM/EDGE	824.2MHz ~ 848.8MHz
	WCDMA	826.4MHz ~ 846.6MHz
	LTE Band 5 (Channel Bandwidth: 1.4MHz)	824.7MHz ~ 848.3MHz
	LTE Band 5 (Channel Bandwidth: 3MHz)	825.5MHz ~ 847.5MHz
	LTE Band 5 (Channel Bandwidth: 5MHz)	826.5MHz ~ 846.5MHz
	LTE Band 5 (Channel Bandwidth: 10MHz)	829MHz ~ 844MHz
	LTE Band 26 (Channel Bandwidth: 1.4MHz)	824.7MHz ~ 848.3MHz
	LTE Band 26 (Channel Bandwidth: 3MHz)	825.5MHz ~ 847.5MHz
	LTE Band 26 (Channel Bandwidth: 5MHz)	826.5MHz ~ 846.5MHz
	LTE Band 26 (Channel Bandwidth: 10MHz)	829MHz ~ 844MHz
	LTE Band 26 (Channel Bandwidth: 15MHz)	831.5MHz ~ 841.5MHz
	MAX. ERP POWER	GSM
EDGE		52.36mW
WCDMA		33.11mW
LTE Band 5 (Channel Bandwidth: 1.4MHz)		30.69mW
LTE Band 5 (Channel Bandwidth: 3MHz)		30.55mW
LTE Band 5 (Channel Bandwidth: 5MHz)		30.69mW



	LTE Band 5 (Channel Bandwidth: 10MHz)	31.19mW
MAX. ERP POWER	LTE Band 26 (Channel Bandwidth: 1.4MHz)	28.12mW
	LTE Band 26 (Channel Bandwidth: 3MHz)	27.67mW
	LTE Band 26 (Channel Bandwidth: 5MHz)	27.8mW
	LTE Band 26 (Channel Bandwidth: 10MHz)	27.8mW
	LTE Band 26 (Channel Bandwidth: 15MHz)	28.18mW
	EMISSION DESIGNATOR GOGN	GSM
EDGE		248KG7W
WCDMA		4M14F9W
LTE Band 26 (Channel Bandwidth: 1.4MHz)		QPSK: 1M10G7D
		16QAM: 1M10W7D
LTE Band 26 (Channel Bandwidth: 3MHz)		QPSK: 2M70G7D
		16QAM: 2M71W7D
LTE Band 26 (Channel Bandwidth: 5MHz)		QPSK: 4M52G7D
		16QAM: 4M52W7D
LTE Band 26 (Channel Bandwidth: 10MHz)		QPSK: 9M00G7D
		16QAM: 9M00W7D
LTE Band 26 (Channel Bandwidth: 15MHz)		QPSK: 13M5G7D
	16QAM: 13M5W7D	
ANTENNA TYPE	ANT0: PIFA Antenna with -7.18dBi gain for GSM850/WCDMA V/LTE B5/LTE B26	
HW VERSION	V2	
SW VERSION	00WW_0_340	
I/O PORTS	Refer to user's manual	
CABLE SUPPLIED	N/A	
EXTREME TEMPERATURE	-10-55°C	
EXTREME VOLTAGE	3.5V - 4.48V	

**NOTE:**

1. For a more detailed features description, please refer to the manufacturer's specifications or the user's manual.
2. The EUT incorporates a SISO function. Physically, the EUT provides one completed transmitter and four receivers.

MODULATION MODE	TX FUNCTION
GSM/GPRS/EDGE	1TX/4RX
WCDMA	1TX/4RX
LTE	1TX/4RX

3. For the test results, the EUT had been tested with all conditions. But only the worst case was shown in test report.
4. Antenna gain and EUT conducted cable loss are provided by the customer, and the laboratory will record the results based on these items that involve these two parameters.
5. The worst-case scenario for all measurements is based on an engineering evaluation made on different modulations. Then, QPSK and 16QAM were observed as the worst mode to LTE bands respectively and set for all conducted and radiated. Output power measurements were measured on QPSK, 16QAM, 64QAM, and 256QAM modulations, and tests other than output power are performed only in worse-case QPSK and 16QAM modulations.

6. List of Accessory:

ACCESSORIES	BRAND	MANUFACTURER	MODEL	SPECIFICATION
LCD Panel	BOE	BOE	BF066XMM-TL4-F900	6.55inch, AMOLED;
Back cover	BIEL	BIEL	Panda-X	158 mm*73 mm*0.6 mm
Bezel	BIEL	BIEL	6103HG02-T6	160 mm_76 mm_8.5 mm
Photo Camera 1	AAC	AAC	P50AD01	50MP,AF
Photo Camera 2	AAC	AAC	W13FD02	13MP Ultra Wide, FF
Video Camera 1	AAC	AAC	T50AD01	50MP Tele, AF
Video Camera 2	AAC	AAC	MA8SD01	108MP+OIS, AF
CPU	Qualcomm	Qualcomm	SM-7435-1-PSP1026-TR-00-0-AB	Platform Baseband Chip_PSP_mmW_8 core_SMT
eMMC1 (=ROM1)	Samsung	Samsung	KM8L9001JM-B624T07	uMCP_254-ball FBGA_128GB_LPDD R4X_64Gb_SMT
eMMC2 (=ROM2)	Samsung	Samsung	KM8F9001JM-B813T07	uMCP_254-ball FBGA_256GB_LPDD R4X_64Gb_SMT
eMMC3 (=ROM3)	Samsung	Samsung	KM8F9001MM-B830T07	uMCP_254-ball FBGA_256GB_LPDD R4X_96Gb_SMT
Battery	HMD	Gaoyuan	HBA4633AA	RatedCapacity:4500mAh/17.51Wh



7. The differences between the first and second supply as follows and the specifications and RF parameters are the same.

Key Component list						
No.	Component	Description	First supply		Second supply	
			Supplier	Spec	Supplier	Spec
1	USB/ Analog audio headsets	Analog Audio Switch	Dioo	DIO4480WL25 Analog switch & MUX_WLCSP25_2.7-5.5V_3-Channel_1000MHz_SMT	Will	WAS4780C-25/TR Analog switch & MUX_CSP-25L_2.7-5.5V_2-Channel_950MHz_SMT
2	Wireless charge	Load Switch	SGM	SGM2575ADYG/TR Load Switch_34 mΩ_11 W_WLCSP_SGM2575ADYG/TR_SGM	Dioo	DIO7290WL4 Load Switch_85 mΩ_11 W_WLCSP-4
3	Sensor	Barometer	Bosch	BMP580 Baroceptor_LGA-10_±0.05 hPa_48 bit_SMT	Goer micro	SPL07-003 Baroceptor_10pin LGA_0.5Pa/°C_24 bit_SMT
4	Sensor	eCOMPASS	VTC	AF6837 Magnetic field sensor_WLCSP_10 LSB/μT_16 bit_I2C_SMT	Memsic	MMC5603NJL Ecompass_MMC5603NJL_M EMSIC_MCOs
5	RF IC	LNA	Will	WS7916DF-6/TR RF_LNA_6-pin DFN_1150 MHz to 1615_SMT	Awinic	AW5005EDNR RF_LNA_AW5005 EDNR_Awinic
6	Receiver	SP2T	Will	WS78022D-6/TR DFN-6_0.1GHz - 3.8GHz_SPDT_GPIO_SMT	Champhill	QX8612GD 0.7 to 2.7GHz_SPDT_2 W_GPIO
7	USB connector	USB type-C connector	LETCON	15-16815-105-M1 USB TYPE C Connector_0.9 mm_16 pin_Female Head (elastic end)_Horizontal_None-waterproof_4.27 mm_Gold_SMT_480M	HRD	UC141-0B100DR0 USB TYPE C Connector_0.9 mm_16 pin_Female Head (elastic end)_Horizontal_None-waterproof_4.3 mm_Gold_SMT_480M



2.2 CONFIGURATION OF SYSTEM UNDER TEST FOR RADIATION EMISSION

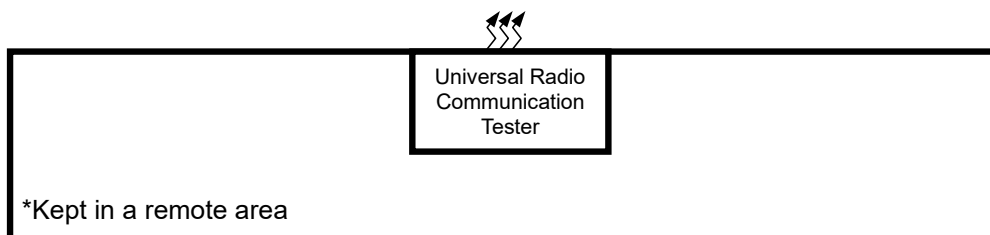
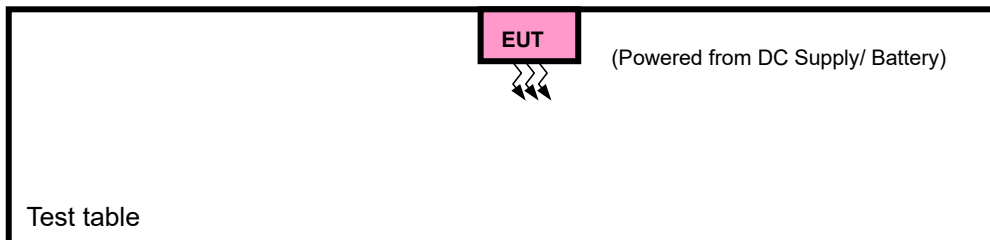
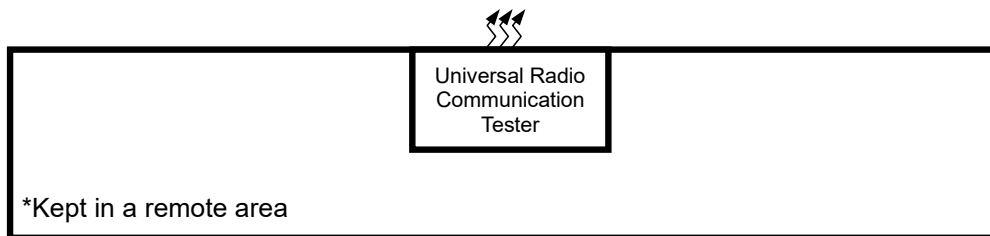
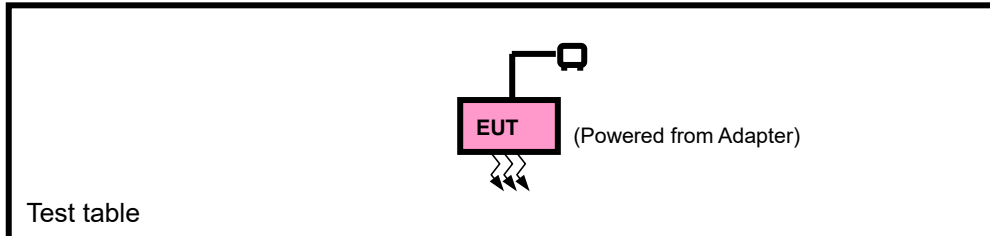



2.3 DESCRIPTION OF SUPPORT UNITS

The EUT has been tested as an independent unit together with other necessary accessories or support units. The following support units or accessories were used to form a representative test configuration during the tests.

NO.	PRODUCT	BRAND	MODEL NO.	SERIAL NO.	FCC ID
1	DC source	Kikusui/JP	PMX18-5A	0000001	N/A

NO.	SIGNAL CABLE DESCRIPTION OF THE ABOVE SUPPORT UNITS
1	DC Line: Unshielded, Detachable 1.0m

2.4 TEST ITEM AND TEST CONFIGURATION

Pre-Scan has been conducted to determine the worst-case mode from all possible combinations between available modulations, data rates, XYZ axis and antenna ports. The worst case in ERP and radiated emission was found when positioned on X-plane for GSM /EDGE /LTE. Following channel(s) was (were) selected for the final test as listed below:

EUT CONFIGURE MODE	DESCRIPTION
A	EUT + Adapter with GSM or WCDMA or LTE link
B	EUT + DC Supply with GSM or WCDMA or LTE link



GSM MODE

EUT CONFIGURE MODE	TEST ITEM	AVAILABLE CHANNEL	TESTED CHANNEL	MODE
A	ERP	128 to 251	128, 189, 251	GSM,EDGE
B	FREQUENCY STABILITY	128 to 251	128, 189, 251	GSM,EDGE
A	OCCUPIED BANDWIDTH	128 to 251	128, 189, 251	GSM,EDGE
A	BAND EDGE	128 to 251	128, 251	GSM,EDGE
A	CONDUCTED EMISSION	128 to 251	128, 189, 251	GSM,EDGE
A	RADIATED EMISSION	128 to 251	128, 189, 251	GSM,EDGE
A	PEAK TO AVERAGE RATIO	128 to 251	128, 189, 251	GSM,EDGE

WCDMA MODE

EUT CONFIGURE MODE	TEST ITEM	AVAILABLE CHANNEL	TESTED CHANNEL	MODE
A	ERP	4132 to 4233	4132, 4182, 4233	WCDMA
B	FREQUENCY STABILITY	4132 to 4233	4132, 4182, 4233	WCDMA
A	OCCUPIED BANDWIDTH	4132 to 4233	4132, 4182, 4233	WCDMA
A	BAND EDGE	4132 to 4233	4132, 4233	WCDMA
A	CONDUCTED EMISSION	4132 to 4233	4132, 4182, 4233	WCDMA
A	RADIATED EMISSION	4132 to 4233	4132, 4182, 4233	WCDMA
A	PEAK TO AVERAGE RATIO	4132 to 4233	4132, 4182, 4233	WCDMA

**LTE BAND 5 MODE**

EUT CONFIGURE MODE	TEST ITEM	Available Channel	Tested Channel	Channel bandwidth	modulation	mode
A	ERP	20407 to 20643	20407, 20525, 20643	1.4MHz	QPSK,16QAM,64QAM	1 RB / 0 RB Offset
		20415 to 20635	20415, 20525, 20635	3MHz	QPSK,16QAM,64QAM	1 RB / 0 RB Offset
		20425 to 20625	20425, 20525, 20625	5MHz	QPSK,16QAM,64QAM	1 RB / 0 RB Offset
		20450 to 20600	20450, 20525, 20600	10MHz	QPSK,16QAM,64QAM	1 RB / 0 RB Offset

Note: 1.This device was tested under all bandwidths, RB configurations and modulations. The worst case was found in QPSK modulation.

2. LTE Band 5 are covered by LTE Band 26, Because it is a subset of LTE Band 26 with the same output power and supported bandwidths, So the test data please refer to LTE Band 26

LTE BAND 26 MODE

EUT CONFIGURE MODE	TEST ITEM	Available Channel	Tested Channel	Channel bandwidth	modulation	mode
A	ERP	26797 to 27033	26797, 26915, 27033	1.4MHz	QPSK,16QAM,64QAM	1 RB / 0 RB Offset
		26805 to 27025	26805, 26915, 27025	3MHz	QPSK,16QAM,64QAM	1 RB / 0 RB Offset
		26815 to 27015	26815, 26915, 27015	5MHz	QPSK,16QAM,64QAM	1 RB / 0 RB Offset
		26840 to 26990	26840, 26915, 26990	10MHz	QPSK,16QAM,64QAM	1 RB / 0 RB Offset
		26865 to 26965	26865, 26915, 26965	15MHz	QPSK,16QAM,64QAM	1 RB / 0 RB Offset
B	FREQUENCY STABILITY	26865 to 26965	26865, 26915, 26965	10MHz	QPSK,16QAM,64QAM	75 RB / 0 RB Offset
A	OCCUPIED BANDWIDTH	26797 to 27033	26797, 26915, 27033	1.4MHz	QPSK,16QAM,64QAM	6 RB / 0 RB Offset
		26805 to 27025	26805, 26915, 27025	3MHz	QPSK,16QAM,64QAM	15 RB / 0 RB Offset
		26815 to 27015	26815, 26915, 27015	5MHz	QPSK,16QAM,64QAM	25 RB / 0 RB Offset
		26840 to 26990	26840, 26915, 26990	10MHz	QPSK,16QAM,64QAM	50 RB / 0 RB Offset
		26865 to 26965	26865, 26915, 26965	15MHz	QPSK,16QAM,64QAM	75 RB / 0 RB Offset
A	PEAK TO AVERAGE RATIO	26865 to 26965	26865, 26915, 26965	15MHz	QPSK,16QAM,64QAM	1 RB / 0 RB Offset 75 RB / 0 RB Offset
A	BAND EDGE	26797 to 27033	26797	1.4 MHz	QPSK,16QAM,64QAM	1 RB / 0 RB Offset 6 RB / 0 RB Offset
			27033	1.4 MHz	QPSK,16QAM,64QAM	1 RB / 5 RB Offset 6 RB / 0 RB Offset
		26805 to 27025	26805	3 MHz	QPSK,16QAM,64QAM	1 RB / 0 RB Offset



						15 RB / 0 RB Offset
		26805 to 27025	27025	3 MHz	QPSK, 16QAM, 64QAM	1 RB / 14 RB Offset
						15 RB / 0 RB Offset
		26815 to 27015	26815	5MHz	QPSK, 16QAM, 64QAM	1 RB / 0 RB Offset
						25 RB / 0 RB Offset
		26815 to 27015	27015	5MHz	QPSK, 16QAM, 64QAM	1 RB / 24 RB Offset
						25 RB / 0 RB Offset
		26840 to 26990	26840	10MHz	QPSK, 16QAM, 64QAM	1 RB / 0 RB Offset
						50 RB / 0 RB Offset
		26840 to 26990	26990	10MHz	QPSK, 16QAM, 64QAM	1 RB / 49 RB Offset
						50 RB / 0 RB Offset
		26865 to 26965	26865	15MHz	QPSK, 16QAM, 64QAM	1 RB / 0 RB Offset
						75 RB / 0 RB Offset
		26865 to 26965	26965	15MHz	QPSK, 16QAM, 64QAM	1 RB / 74 RB Offset
						75 RB / 0 RB Offset
A	CONDUCTED EMISSION	26797 to 27033	26797, 26915, 27033	1.4MHz	QPSK, 16QAM, 64QAM	1 RB / 0 RB Offset
		26805 to 27025	26805, 26915, 27025	3MHz	QPSK, 16QAM, 64QAM	1 RB / 0 RB Offset
		26815 to 27015	26815, 26915, 27015	5MHz	QPSK, 16QAM, 64QAM	1 RB / 0 RB Offset
		26840 to 26990	26840, 26915, 26990	10MHz	QPSK, 16QAM, 64QAM	1 RB / 0 RB Offset
		26865 to 26965	26865, 26915, 26965	15MHz	QPSK, 16QAM, 64QAM	1 RB / 0 RB Offset
A	RADIATED EMISSION	26797 to 27033	26915	1.4MHz	QPSK	1 RB / 0 RB Offset
		26805 to 27025	26915	3MHz	QPSK	1 RB / 0 RB Offset
		26815 to 27015	26815, 26915, 27015	5MHz	QPSK	1 RB / 0 RB Offset
		26840 to 26990	26915	10MHz	QPSK	1 RB / 0 RB Offset
		26865 to 26965	26915	15MHz	QPSK	1 RB / 0 RB Offset

Note: This device was tested under all bandwidths, RB configurations and modulations. The worst case was found in QPSK modulation.



TEST CONDITION:

TEST ITEM	ENVIRONMENTAL CONDITIONS	INPUT POWER	TESTED BY
ERP	23deg. C, 70%RH	DC 5.0V/9.0V /12.0VBy Adapter	Jace Hu
FREQUENCY STABILITY	23deg. C, 70%RH	DC 3.5V/3.89V/4.48V By DC Supply	James Fu
OCCUPIED BANDWIDTH	23deg. C, 70%RH	DC 5.0V/9.0V /12.0VBy Adapter	James Fu
BAND EDGE	23deg. C, 70%RH	DC 5.0V/9.0V /12.0VBy Adapter	James Fu
CONDUCTED EMISSION	23deg. C, 70%RH	DC 5.0V/9.0V /12.0VBy Adapter	James Fu
RADIATED EMISSION	23deg. C, 70%RH	DC 5.0V/9.0V /12.0VBy Adapter	Jace Hu
PEAK TO AVERAGE RATIO	23deg. C, 70%RH	DC 5.0V/9.0V /12.0VBy Adapter	James Fu

2.5 EUT OPERATING CONDITIONS

The EUT makes a call to the communication simulator. The communication simulator station system controlled a EUT to export maximum output power under transmission mode and specific channel frequency



**BUREAU
VERITAS**

Test Report No.: PSU-NQN2403180115RF05

2.6 GENERAL DESCRIPTION OF APPLIED STANDARDS

The EUT is a RF product. According to the specifications of the manufacturer, it must comply with the requirements of the following standards:

FCC 47 CFR Part 2

FCC 47 CFR Part 22

KDB 971168 D01 Power Meas License Digital Systems v03r01

ANSI/TIA/EIA-603-D

ANSI/TIA/EIA-603-E

ANSI C63.26-2015

NOTE: All test items have been performed and recorded as per the above standards.



3 TEST TYPES AND RESULTS

3.1 OUTPUT POWER MEASUREMENT

3.1.1 LIMITS OF OUTPUT POWER MEASUREMENT

Mobile / Portable station are limited to 7 watts e.r.p.

3.1.2 TEST PROCEDURES

EIRP / ERP MEASUREMENT:

Per KDB 971168 D01 Power Meas License Digital Systems v03r01 or subclause 5.2.5.5 of ANSI C63.26-2015, the relevant equation for determining the ERP or EIRP from the conducted RF output power measured using the guidance provided above is:

$$\text{ERP or EIRP} = P_{\text{Meas}} + G_{\text{T}} - L_{\text{C}}$$

Where:

ERP or EIRP = effective radiated power or equivalent isotropically radiated power, respectively

(expressed in the same units as P_{Meas} , typically dBW or dBm);

P_{Meas} = measured transmitter output power or PSD, in dBm or dBW;

G_{T} = gain of the transmitting antenna, in dBd (ERP) or dBi (EIRP);

L_{C} = signal attenuation in the connecting cable between the transmitter and antenna, in dB.

CONDUCTED POWER MEASUREMENT:

The EUT was set up for the maximum power with WCDMA link data modulation and link up with simulator. Set the EUT to transmit under low, middle and high channel and record the power level shown on simulator.



3.1.3 TEST SETUP

EIRP / ERP Measurement:

CONDUCTED POWER MEASUREMENT:

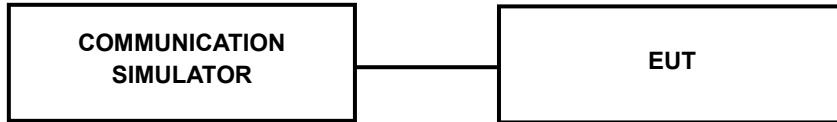

3.1.4 TEST RESULTS

CONDUCTED OUTPUT POWER (dBm)

Band	GSM850		
Channel	128	189	251
Frequency (MHz)	824.2	836.4	848.8
GSM	32.54	33.47	33.45
GPRS 1Tx Slot	32.53	33.46	33.67
GPRS 2Tx Slot	30.64	31.24	31.15
GPRS 3Tx Slot	28.52	29.16	29.02
GPRS 4Tx Slot	27.32	28.08	28.07
EDGE 1Tx Slot	26.14	26.42	26.52
EDGE 2Tx Slot	24.52	25.53	25.43
EDGE 3Tx Slot	22.37	22.99	22.84
EDGE 4Tx Slot	21.32	22.09	21.87

Band	WCDMA V		
Channel	4132	4182	4233
Frequency (MHz)	826.4	836.4	846.6
RMC 12.2K	24.52	24.53	24.48
HSDPA Subtest-1	23.86	23.72	23.81
HSDPA Subtest-2	23.84	23.78	23.66
HSDPA Subtest-3	23.26	23.29	23.24
HSDPA Subtest-4	23.24	23.29	23.12
DC-HSDPA Subtest-1	23.73	23.64	23.74
DC-HSDPA Subtest-2	23.58	23.73	23.70
DC-HSDPA Subtest-3	23.24	23.16	23.13
DC-HSDPA Subtest-4	23.30	23.13	23.21
HSUPA Subtest-1	23.63	23.85	23.73
HSUPA Subtest-2	22.71	22.68	22.61
HSUPA Subtest-3	23.13	23.18	23.18
HSUPA Subtest-4	22.81	22.78	22.71
HSUPA Subtest-5	23.70	23.78	23.72



LTE Band 5

Band/BW	Modulation	RB Size	RB Offset	Low CH 20407	Mid CH 20525	High CH 20643
				Frequency 824.7 MHz	Frequency 836.5 MHz	Frequency 848.3 MHz
5/ 1.4	QPSK	1	0	24.11	24.13	24.19
		1	2	24.18	24.18	24.08
		1	5	24.10	24.18	24.10
		3	0	24.09	24.12	24.05
		3	1	24.18	24.14	24.13
		3	3	24.11	24.13	24.20
		6	0	23.17	23.10	23.09
	16QAM	1	0	23.44	23.33	23.43
		1	2	23.28	23.40	23.38
		1	5	23.18	23.39	23.18
		3	0	23.18	23.09	23.07
		3	1	23.23	23.25	23.13
		3	3	23.09	23.21	23.23
		6	0	22.21	22.22	22.16
	64QAM	1	0	22.39	22.32	22.34
		1	2	22.33	22.40	22.15
		1	5	22.12	22.21	22.22
		3	0	22.11	22.23	22.07
		3	1	22.16	22.19	22.10
		3	3	22.21	22.21	22.18
		6	0	21.20	21.15	21.13



Band/BW	Modulation	RB Size	RB Offset	Low CH 20415	Mid CH 20525	High CH 20635
				Frequency 825.5 MHz	Frequency 836.5 MHz	Frequency 847.5 MHz
5 / 3	QPSK	1	0	24.12	24.13	24.10
		1	7	24.17	24.17	24.10
		1	14	24.02	24.18	24.08
		8	0	23.16	23.14	23.11
		8	3	23.28	23.21	23.17
		8	7	23.19	23.28	23.13
		15	0	23.17	23.11	23.19
	16QAM	1	0	23.40	23.37	23.34
		1	7	23.23	23.49	23.39
		1	14	23.26	23.36	23.32
		8	0	22.17	22.10	22.17
		8	3	22.20	22.19	22.10
		8	7	22.23	22.23	22.19
		15	0	22.14	22.20	22.15
	64QAM	1	0	22.26	22.27	22.34
		1	7	22.21	22.39	22.22
		1	14	22.23	22.28	22.30
		8	0	21.11	21.17	21.05
		8	3	21.19	21.10	21.18
		8	7	21.19	21.23	21.10
		15	0	21.15	21.16	21.16



Band/BW	Modulation	RB Size	RB Offset	Low CH 20425	Mid CH 20525	High CH 20625
				Frequency 826.5 MHz	Frequency 836.5 MHz	Frequency 846.5 MHz
5 / 5	QPSK	1	0	24.09	24.17	24.16
		1	12	24.10	24.20	24.05
		1	24	24.05	24.13	24.09
		12	0	23.18	23.09	23.11
		12	6	23.18	23.23	23.16
		12	13	23.19	23.23	23.15
		25	0	23.20	23.14	23.17
	16QAM	1	0	23.40	23.33	23.44
		1	12	23.24	23.40	23.37
		1	24	23.24	23.38	23.20
		12	0	22.11	22.14	22.09
		12	6	22.18	22.17	22.19
		12	13	22.14	22.09	22.26
		25	0	22.14	22.30	22.13
	64QAM	1	0	22.38	22.33	22.29
		1	12	22.25	22.40	22.09
		1	24	22.16	22.32	22.30
		12	0	21.05	21.20	21.11
		12	6	21.18	21.14	21.12
		12	13	21.20	21.26	21.09
		25	0	21.21	21.20	21.11



Band/BW	Modulation	RB Size	RB Offset	Low CH 20450	Mid CH 20525	High CH 20600
				Frequency 829 MHz	Frequency 836.5 MHz	Frequency 844 MHz
5/ 10	QPSK	1	0	24.23	24.27	24.25
		1	24	24.21	24.25	24.19
		1	49	24.11	24.19	24.13
		25	0	23.30	23.31	23.26
		25	12	23.26	23.26	23.19
		25	25	23.23	23.23	23.22
		50	0	23.25	23.28	23.22
	16QAM	1	0	23.45	23.42	23.46
		1	24	23.34	23.51	23.47
		1	49	23.31	23.46	23.33
		25	0	22.19	22.16	22.19
		25	12	22.27	22.27	22.25
		25	25	22.24	22.24	22.27
		50	0	22.23	22.31	22.23
	64QAM	1	0	22.41	22.39	22.39
		1	24	22.34	22.41	22.23
		1	49	22.26	22.36	22.32
		25	0	21.19	21.26	21.12
		25	12	21.27	21.23	21.22
		25	25	21.22	21.29	21.24
		50	0	21.26	21.21	21.18



LTE BAND 26

Band/BW	Modulation	RB Size	RB Offset	Low CH 26797	Mid CH 26915	High CH 27033
				Frequency 824.7 MHz	Frequency 836.5 MHz	Frequency 848.3 MHz
26/ 1.4	QPSK	1	0	23.64	23.73	23.66
		1	2	23.80	23.67	23.54
		1	5	23.55	23.82	23.66
		3	0	23.63	23.58	23.81
		3	1	23.51	23.57	23.81
		3	3	23.61	23.54	23.73
		6	0	22.67	22.62	22.69
	16QAM	1	0	23.02	22.89	23.13
		1	2	22.94	23.05	22.90
		1	5	22.89	22.84	22.82
		3	0	22.51	22.57	22.90
		3	1	22.53	22.54	22.85
		3	3	22.62	22.52	22.73
		6	0	21.94	21.71	21.69
	64QAM	1	0	21.86	21.97	21.89
		1	2	21.92	21.78	21.86
		1	5	21.89	21.83	21.74
		3	0	21.72	21.54	21.95
		3	1	21.68	21.54	21.92
		3	3	21.53	21.56	21.89
		6	0	20.71	20.67	20.73



Band/BW	Modulation	RB Size	RB Offset	Low CH 26805	Mid CH 26915	High CH 27025
				Frequency 825.5 MHz	Frequency 836.5 MHz	Frequency 847.5 MHz
26/ 3	QPSK	1	0	23.66	23.68	23.56
		1	7	23.62	23.67	23.55
		1	14	23.55	23.75	23.60
		8	0	22.64	22.62	22.75
		8	3	22.67	22.67	22.67
		8	7	22.58	22.67	22.71
		15	0	22.68	22.65	22.65
	16QAM	1	0	22.87	22.81	23.01
		1	7	22.96	22.97	22.83
		1	14	22.89	22.82	22.72
		8	0	21.59	21.58	21.75
		8	3	21.69	21.70	21.73
		8	7	21.74	21.63	21.71
		15	0	21.87	21.64	21.59
	64QAM	1	0	21.80	21.95	21.87
		1	7	21.86	21.67	21.90
		1	14	21.80	21.70	21.60
		8	0	20.64	20.63	20.75
		8	3	20.71	20.66	20.82
		8	7	20.60	20.67	20.69
		15	0	20.72	20.61	20.73



Band/BW	Modulation	RB Size	RB Offset	Low CH 26815	Mid CH 26915	High CH 27015
				Frequency 826.5 MHz	Frequency 836.5 MHz	Frequency 846.5 MHz
26/ 5	QPSK	1	0	23.77	23.70	23.60
		1	12	23.74	23.58	23.59
		1	24	23.67	23.71	23.63
		12	0	22.70	22.66	22.71
		12	6	22.65	22.60	22.60
		12	13	22.56	22.63	22.58
		25	0	22.56	22.63	22.67
	16QAM	1	0	22.83	22.84	23.04
		1	12	22.94	22.93	22.86
		1	24	22.82	22.77	22.73
		12	0	21.59	21.60	21.68
		12	6	21.67	21.67	21.76
		12	13	21.72	21.73	21.74
		25	0	21.86	21.68	21.56
	64QAM	1	0	21.75	21.81	21.86
		1	12	21.72	21.67	21.85
		1	24	21.75	21.68	21.62
		12	0	20.57	20.66	20.81
		12	6	20.84	20.61	20.80
		12	13	20.69	20.61	20.80
		25	0	20.72	20.57	20.73



Band/BW	Modulation	RB Size	RB Offset	Low CH 26840	Mid CH 26915	High CH 26990
				Frequency 829 MHz	Frequency 836.5 MHz	Frequency 844 MHz
26/10	QPSK	1	0	23.77	23.72	23.54
		1	24	23.66	23.61	23.53
		1	49	23.65	23.64	23.58
		25	0	22.76	22.71	22.71
		25	12	22.65	22.57	22.64
		25	25	22.53	22.66	22.65
		50	0	22.53	22.65	22.63
	16QAM	1	0	22.93	22.91	23.02
		1	24	22.86	22.95	22.90
		1	49	22.88	22.79	22.83
		25	0	21.55	21.63	21.68
		25	12	21.68	21.67	21.79
		25	25	21.69	21.73	21.66
		50	0	21.83	21.57	21.56
	64QAM	1	0	21.81	21.95	21.89
		1	24	21.80	21.67	21.87
		1	49	21.72	21.62	21.56
		25	0	20.65	20.70	20.82
		25	12	20.85	20.60	20.79
		25	25	20.71	20.62	20.81
		50	0	20.68	20.54	20.73



Band/BW	Modulation	RB Size	RB Offset	Low CH 26865	Mid CH 26915	High CH 26965
				Frequency 831.5 MHz	Frequency 836.5 MHz	Frequency 841.5 MHz
26/ 15	QPSK	1	0	23.83	23.78	23.68
		1	37	23.66	23.63	23.59
		1	74	23.78	23.76	23.65
		36	0	22.85	22.73	22.84
		36	19	22.73	22.68	22.75
		36	39	22.77	22.68	22.73
		75	0	22.80	22.68	22.72
	16QAM	1	0	22.95	22.92	23.11
		1	37	23.04	22.98	22.94
		1	74	23.02	22.87	22.84
		36	0	21.82	21.72	21.83
		36	19	21.79	21.76	21.85
		36	39	21.89	21.74	21.77
		75	0	21.74	21.69	21.69
	64QAM	1	0	21.99	21.96	21.95
		1	37	21.91	21.81	21.91
		1	74	21.87	21.77	21.71
		36	0	20.84	20.76	20.83
		36	19	20.70	20.68	20.85
		36	39	20.86	20.75	20.82
		75	0	20.78	20.67	20.76



ERP POWER (dBm)

GSM

Channel	Frequency (MHz)	Conducted Power (dBm)	G _T -L _c (dB)	ERP (dBm)	ERP (mW)	Limit (W)
128	824.2	32.54	-7.18	23.21	209.41	7
189	836.4	33.47	-7.18	24.14	259.42	7
251	848.8	33.67	-7.18	24.34	271.64	7

REMARKS: ERP Output Power (dBm) = EIRP (dBm) -2.15(dB).

EDGE

Channel	Frequency (MHz)	Conducted Power (dBm)	G _T -L _c (dB)	ERP (dBm)	ERP (mW)	Limit (W)
128	824.2	26.14	-7.18	16.81	47.97	7
189	836.4	26.42	-7.18	17.09	51.17	7
251	848.8	26.52	-7.18	17.19	52.36	7

REMARKS: ERP Output Power (dBm) = EIRP (dBm) -2.15(dB).

WCDMA

Channel	Frequency (MHz)	Conducted Power (dBm)	G _T -L _c (dB)	ERP (dBm)	ERP (mW)	Limit (W)
4132	826.4	24.52	-7.18	15.19	33.04	7
4182	836.4	24.53	-7.18	15.2	33.11	7
4233	846.6	24.48	-7.18	15.15	32.73	7

REMARKS: ERP Output Power (dBm) = EIRP (dBm) -2.15(dB).



LTE BAND 5

CHANNEL BANDWIDTH: 1.4MHz QPSK

Channel	Frequency (MHz)	Conducted Power (dBm)	G _T -L _C (dB)	ERP (dBm)	ERP (mW)	Limit (W)
20407	824.7	24.18	-7.18	14.85	30.55	7
20525	836.5	24.18	-7.18	14.85	30.55	7
20643	848.3	24.2	-7.18	14.87	30.69	7

CHANNEL BANDWIDTH: 1.4MHz 16QAM

Channel	Frequency (MHz)	Conducted Power (dBm)	G _T -L _C (dB)	ERP (dBm)	ERP (mW)	Limit (W)
20407	824.7	23.44	-7.18	14.11	25.76	7
20525	836.5	23.4	-7.18	14.07	25.53	7
20643	848.3	23.43	-7.18	14.1	25.7	7

CHANNEL BANDWIDTH: 1.4MHz 64QAM

Channel	Frequency (MHz)	Conducted Power (dBm)	G _T -L _C (dB)	ERP (dBm)	ERP (mW)	Limit (W)
20407	824.7	22.39	-7.18	13.06	20.23	7
20525	836.5	22.4	-7.18	13.07	20.28	7
20643	848.3	22.34	-7.18	13.01	20	7



CHANNEL BANDWIDTH: 3MHz QPSK

Channel	Frequency (MHz)	Conducted Power (dBm)	G _{T-Lc} (dB)	ERP (dBm)	ERP (mW)	Limit (W)
20415	825.5	24.17	-7.18	14.84	30.48	7
20525	836.5	24.18	-7.18	14.85	30.55	7
20635	847.5	24.1	-7.18	14.77	29.99	7

CHANNEL BANDWIDTH: 3MHz 16QAM

Channel	Frequency (MHz)	Conducted Power (dBm)	G _{T-Lc} (dB)	ERP (dBm)	ERP (mW)	Limit (W)
20415	825.5	23.4	-7.18	14.07	25.53	7
20525	836.5	23.49	-7.18	14.16	26.06	7
20635	847.5	23.39	-7.18	14.06	25.47	7

CHANNEL BANDWIDTH: 3MHz 64QAM

Channel	Frequency (MHz)	Conducted Power (dBm)	G _{T-Lc} (dB)	ERP (dBm)	ERP (mW)	Limit (W)
20415	825.5	22.26	-7.18	12.93	19.63	7
20525	836.5	22.39	-7.18	13.06	20.23	7
20635	847.5	22.34	-7.18	13.01	20	7



CHANNEL BANDWIDTH: 5MHz QPSK

Channel	Frequency (MHz)	Conducted Power (dBm)	G _T -L _C (dB)	ERP (dBm)	ERP (mW)	Limit (W)
20425	826.5	24.1	-7.18	14.77	29.99	7
20525	836.5	24.2	-7.18	14.87	30.69	7
20625	846.5	24.16	-7.18	14.83	30.41	7

CHANNEL BANDWIDTH: 5MHz 16QAM

Channel	Frequency (MHz)	Conducted Power (dBm)	G _T -L _C (dB)	ERP (dBm)	ERP (mW)	Limit (W)
20425	826.5	23.4	-7.18	14.07	25.53	7
20525	836.5	23.4	-7.18	14.07	25.53	7
20625	846.5	23.44	-7.18	14.11	25.76	7

CHANNEL BANDWIDTH: 5MHz 64QAM

Channel	Frequency (MHz)	Conducted Power (dBm)	G _T -L _C (dB)	ERP (dBm)	ERP (mW)	Limit (W)
20425	826.5	22.38	-7.18	13.05	20.18	7
20525	836.5	22.4	-7.18	13.07	20.28	7
20625	846.5	22.3	-7.18	12.97	19.82	7



CHANNEL BANDWIDTH: 10MHz QPSK

Channel	Frequency (MHz)	Conducted Power (dBm)	G _{T-Lc} (dB)	ERP (dBm)	ERP (mW)	Limit (W)
20450	829.0	24.23	-7.18	14.9	30.9	7
20525	836.5	24.27	-7.18	14.94	31.19	7
20600	844.0	24.25	-7.18	14.92	31.05	7

CHANNEL BANDWIDTH: 10MHz 16QAM

Channel	Frequency (MHz)	Conducted Power (dBm)	G _{T-Lc} (dB)	ERP (dBm)	ERP (mW)	Limit (W)
20450	829.0	23.45	-7.18	14.12	25.82	7
20525	836.5	23.51	-7.18	14.18	26.18	7
20600	844.0	23.47	-7.18	14.14	25.94	7

CHANNEL BANDWIDTH: 10MHz 64QAM

Channel	Frequency (MHz)	Conducted Power (dBm)	G _{T-Lc} (dB)	ERP (dBm)	ERP (mW)	Limit (W)
20450	829.0	22.41	-7.18	13.08	20.32	7
20525	836.5	22.41	-7.18	13.08	20.32	7
20600	844.0	22.39	-7.18	13.06	20.23	7

REMARKS: ERP Output Power (dBm) = EIRP (dBm) -2.15(dB).



LTE BAND 26

CHANNEL BANDWIDTH: 1.4MHz QPSK

Channel	Frequency (MHz)	Conducted Power (dBm)	G _T -L _C (dB)	ERP (dBm)	ERP (mW)	Limit (W)
26797	824.7	23.8	-7.18	14.47	27.99	7
26915	836.5	23.82	-7.18	14.49	28.12	7
27033	848.3	23.81	-7.18	14.48	28.05	7

CHANNEL BANDWIDTH: 1.4MHz 16QAM

Channel	Frequency (MHz)	Conducted Power (dBm)	G _T -L _C (dB)	ERP (dBm)	ERP (mW)	Limit (W)
26797	824.7	23.02	-7.18	13.69	23.39	7
26915	836.5	23.05	-7.18	13.72	23.55	7
27033	848.3	23.13	-7.18	13.8	23.99	7

CHANNEL BANDWIDTH: 1.4MHz 64QAM

Channel	Frequency (MHz)	Conducted Power (dBm)	G _T -L _C (dB)	ERP (dBm)	ERP (mW)	Limit (W)
26797	824.7	21.92	-7.18	12.59	18.16	7
26915	836.5	21.97	-7.18	12.64	18.37	7
27033	848.3	21.95	-7.18	12.62	18.28	7



CHANNEL BANDWIDTH: 3MHz QPSK

Channel	Frequency (MHz)	Conducted Power (dBm)	G _T -L _C (dB)	ERP (dBm)	ERP (mW)	Limit (W)
26805	825.5	23.66	-7.18	14.33	27.1	7
26915	836.5	23.75	-7.18	14.42	27.67	7
27025	847.5	23.6	-7.18	14.27	26.73	7

CHANNEL BANDWIDTH: 3MHz 16QAM

Channel	Frequency (MHz)	Conducted Power (dBm)	G _T -L _C (dB)	ERP (dBm)	ERP (mW)	Limit (W)
26805	825.5	22.96	-7.18	13.63	23.07	7
26915	836.5	22.97	-7.18	13.64	23.12	7
27025	847.5	23.01	-7.18	13.68	23.33	7

CHANNEL BANDWIDTH: 3MHz 64QAM

Channel	Frequency (MHz)	Conducted Power (dBm)	G _T -L _C (dB)	ERP (dBm)	ERP (mW)	Limit (W)
26805	825.5	21.86	-7.18	12.53	17.91	7
26915	836.5	21.95	-7.18	12.62	18.28	7
27025	847.5	21.9	-7.18	12.57	18.07	7



CHANNEL BANDWIDTH: 5MHz QPSK

Channel	Frequency (MHz)	Conducted Power (dBm)	G _{T-Lc} (dB)	ERP (dBm)	ERP (mW)	Limit (W)
26815	826.5	23.77	-7.18	14.44	27.8	7
26915	836.5	23.71	-7.18	14.38	27.42	7
27015	846.5	23.63	-7.18	14.3	26.92	7

CHANNEL BANDWIDTH: 5MHz 16QAM

Channel	Frequency (MHz)	Conducted Power (dBm)	G _{T-Lc} (dB)	ERP (dBm)	ERP (mW)	Limit (W)
26815	826.5	22.94	-7.18	13.61	22.96	7
26915	836.5	22.93	-7.18	13.6	22.91	7
27015	846.5	23.04	-7.18	13.71	23.5	7

CHANNEL BANDWIDTH: 5MHz 64QAM

Channel	Frequency (MHz)	Conducted Power (dBm)	G _{T-Lc} (dB)	ERP (dBm)	ERP (mW)	Limit (W)
26815	826.5	21.75	-7.18	12.42	17.46	7
26915	836.5	21.81	-7.18	12.48	17.7	7
27015	846.5	21.86	-7.18	12.53	17.91	7



CHANNEL BANDWIDTH: 10MHz QPSK

Channel	Frequency (MHz)	Conducted Power (dBm)	G _{T-Lc} (dB)	ERP (dBm)	ERP (mW)	Limit (W)
26840	829	23.77	-7.18	14.44	27.8	7
26915	836.5	23.72	-7.18	14.39	27.48	7
26990	844	23.58	-7.18	14.25	26.61	7

CHANNEL BANDWIDTH: 10MHz 16QAM

Channel	Frequency (MHz)	Conducted Power (dBm)	G _{T-Lc} (dB)	ERP (dBm)	ERP (mW)	Limit (W)
26840	829	22.93	-7.18	13.6	22.91	7
26915	836.5	22.95	-7.18	13.62	23.01	7
26990	844	23.02	-7.18	13.69	23.39	7

CHANNEL BANDWIDTH: 10MHz 64QAM

Channel	Frequency (MHz)	Conducted Power (dBm)	G _{T-Lc} (dB)	ERP (dBm)	ERP (mW)	Limit (W)
26840	829	21.81	-7.18	12.48	17.7	7
26915	836.5	21.95	-7.18	12.62	18.28	7
26990	844	21.89	-7.18	12.56	18.03	7



CHANNEL BANDWIDTH: 15MHz QPSK

Channel	Frequency (MHz)	Conducted Power (dBm)	G _T -L _C (dB)	ERP (dBm)	ERP (mW)	Limit (W)
26865	831.5	23.83	-7.18	14.5	28.18	7
26915	836.5	23.78	-7.18	14.45	27.86	7
26965	841.5	23.68	-7.18	14.35	27.23	7

CHANNEL BANDWIDTH: 15MHz 16QAM

Channel	Frequency (MHz)	Conducted Power (dBm)	G _T -L _C (dB)	ERP (dBm)	ERP (mW)	Limit (W)
26865	831.5	23.04	-7.18	13.71	23.5	7
26915	836.5	22.98	-7.18	13.65	23.17	7
26965	841.5	23.11	-7.18	13.78	23.88	7

CHANNEL BANDWIDTH: 15MHz 64QAM

Channel	Frequency (MHz)	Conducted Power (dBm)	G _T -L _C (dB)	ERP (dBm)	ERP (mW)	Limit (W)
26865	831.5	21.99	-7.18	12.66	18.45	7
26915	836.5	21.96	-7.18	12.63	18.32	7
26965	841.5	21.95	-7.18	12.62	18.28	7

REMARKS: ERP Output Power (dBm) = EIRP (dBm) -2.15(dB).



3.2 FREQUENCY STABILITY MEASUREMENT

3.2.1 LIMITS OF FREQUENCY STABILITY MEASUREMENT

1.5 ppm is for base and fixed station. 2.5 ppm is for mobile station.

3.2.2 TEST PROCEDURE

- a. Device is placed at the oven room. The oven room could control the temperatures and humidity. Power warm up is at least 15 min and power applied should perform before recording frequency error.
- b. EUT is connected the external power supply to control the DC input power. The test voltage range is from minimum to maximum working voltage. Each step shall be record the frequency error rate.
- c. The temperature range step is 10 degrees in this test items. All temperature levels shall be hold the $\pm 0.5^{\circ}\text{C}$ during the measurement testing. The each temperature step shall be at least 0.5 hours, consider the EUT could be test under the stability condition.

NOTE: The frequency error was recorded frequency error from the communication simulator.

3.2.3 TEST SETUP

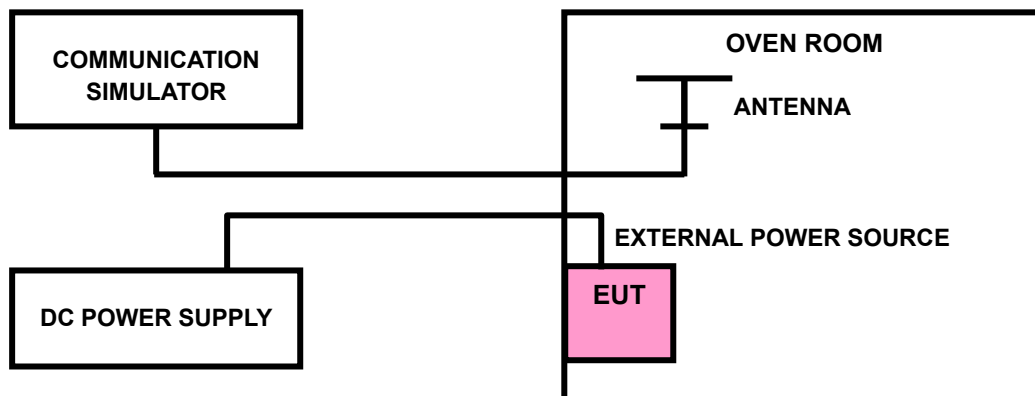



**BUREAU
VERITAS**

Test Report No.: PSU-NQN2403180115RF05

3.2.4 TEST RESULTS

Please Refer to Appendix E Of this test report.

Note: VL = Low voltage(3.5V); VN/NV = Normal voltage(3.89V); VH = High voltage(4.48V);
NT = Normal temperature (25°C)



3.3 OCCUPIED BANDWIDTH MEASUREMENT

3.3.1 LIMITS OF OCCUPIED BANDWIDTH MEASUREMENT

The width of a frequency band such that, below the lower and above the upper frequency limits, the mean powers emitted are each equal to a specified percentage 0.5 % of the total mean power of a given emission.

3.3.2 TEST SETUP

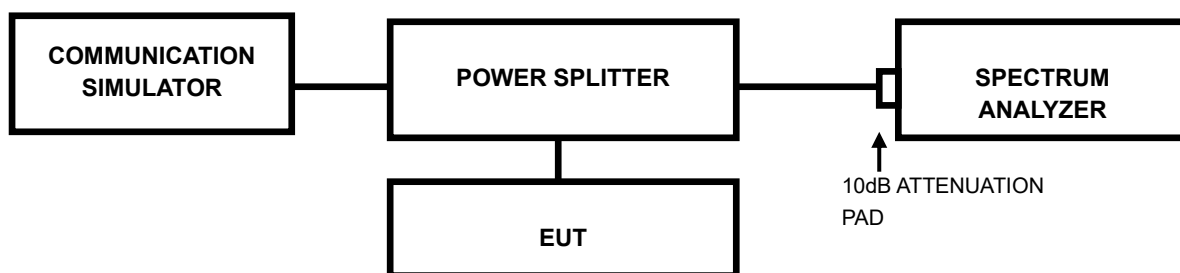

3.3.3 TEST PROCEDURES

- The conducted occupied bandwidth used the power splitter via EUT RF power connector between simulation base station and spectrum analyzer.
- Use OBW measurement function of Spectrum analyzer to measure 99 % occupied bandwidth.



Test Report No.: PSU-NQN2403180115RF05

3.3.4 TEST RESULTS

Please Refer to Appendix E Of this test report.



3.4 BAND EDGE MEASUREMENT

3.4.1 LIMITS OF BAND EDGE MEASUREMENT

Power of any emission outside of the authorized operating frequency ranges must be attenuated below the transmitting power (P) by a factor of at least $43 + 10 \log(P)$ dB. In the 1 MHz bands immediately outside and adjacent to the frequency block a resolution bandwidth of at least one percent of the emission bandwidth of the fundamental emission of the transmitter may be employed.

3.4.2 TEST SETUP

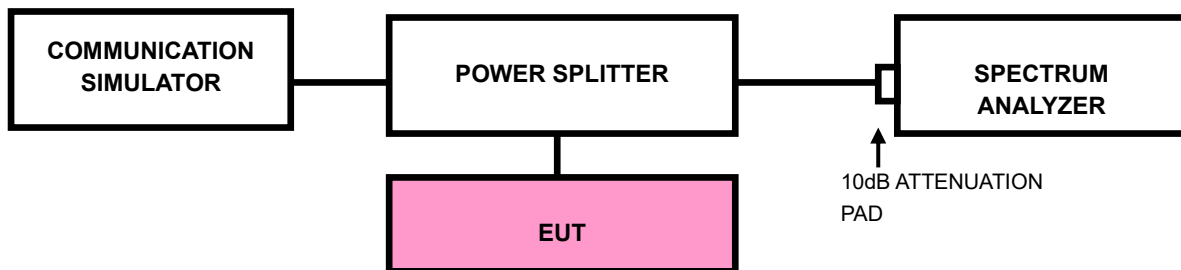



3.4.3 TEST PROCEDURES

- a) All measurements were done at low and high operational frequency range
- b) Connect the transmitter to the spectrum analyzer via coaxial cable while ensuring proper impedance matching.
- c) Tune the analyzer to the nominal center frequency of the emission bandwidth (EBW)
- d) .Set the resolution bandwidth (RBW) $\geq 1\%$ EBW in the 1MHz band immediately outside and adjacent to the band edge.
- e) Beyond the 1MHz band from the band edge, RBW=1MHz was used.
- f) Set the video bandwidth (VBW) to $\geq 3 \times$ RBW.
- g) Select the average power (RMS) display detector.
- h) Set the number of measurement points to ≥ 1001 .
- i) Use auto-coupled sweep time.
- j) Perform the measurement over an interval of time when the transmission is continuous and at its maximum power level.
- k) The RF fundamental frequency should be excluded against the limit line in the operating frequency band and use RBW is 10KHz or 100KHz.
- l) Record the max trace plot into the test report.



Test Report No.: PSU-NQN2403180115RF05

3.4.4 TEST RESULTS

Please Refer to Appendix E Of this test report.



3.5 CONDUCTED SPURIOUS EMISSIONS

3.5.1 LIMITS OF CONDUCTED SPURIOUS EMISSIONS MEASUREMENT

The power of any emission outside of the authorized operating frequency ranges must be attenuated below the transmitting power (P) by a factor of at least $43 + 10 \log(P)$ dB. The emission limit equal to -13dBm .

3.5.2 TEST PROCEDURE

- a. The EUT makes a phone call to the communication simulator. All measurements were done at low, middle and high operational frequency range.
- b. Measuring frequency range is from 9kHz up to a frequency including its 10th harmonic. 10dB attenuation pad is connected with spectrum. RBW=1MHz and VBW=3MHz is used for conducted emission measurement.

3.5.3 TEST SETUP

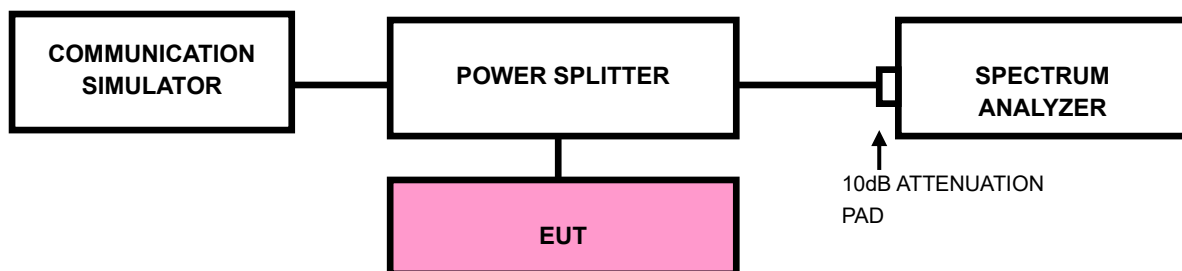



**BUREAU
VERITAS**

Test Report No.: PSU-NQN2403180115RF05

3.5.4 TEST RESULTS

NOTE : The 9K~30MHz amplitude of spurious emissions attenuated more than 20 dB below the permissible value is not required in the report.

Please Refer to Appendix E Of this test report.



3.6 RADIATED EMISSION MEASUREMENT

3.6.1 LIMITS OF RADIATED EMISSION MEASUREMENT

The power of any emission outside of the authorized operating frequency ranges must be attenuated below the transmitting power (P) by a factor of at least $43 + 10 \log(P)$ dB. The emission limit equal to -13dBm .

3.6.2 TEST PROCEDURES

- a. Substitution method is used for E.I.R.P measurement. In the semi-anechoic chamber, EUT placed on the 0.8m height of Turn Table, rotated the table around 360 degrees to search the maximum radiation power and receiver antenna shall be rotated vertical and horizontal polarization and moved height from 1m to 4m to find the maximum polar radiated power. The "Read Value" is the spectrum reading the maximum power value.
- b. The substitution horn antenna is substituted for EUT at the same position and signals generator export the CW signal to the substitution antenna via a TX cable. Rotated the Turn Table and moved receiving antenna to find the maximum radiation power. Adjust output power level of S.G to get a Value of spectrum reading equal to "Read Value " of step a. Record the power level of S.G
- c. $\text{EIRP} = \text{Output power level of S.G} - \text{TX cable loss} + \text{Antenna gain of substitution horn.}$
- d. E.R.P power can be calculated form E.I.R.P power by subtracting the gain of dipole,
 $\text{E.R.P power} = \text{E.I.P.R power} - 2.15\text{dBi.}$

NOTE: The resolution bandwidth and video bandwidth of test receiver/spectrum analyzer is 1MHz/3MHz.

3.6.3 DEVIATION FROM TEST STANDARD

No deviation



3.6.4 TEST SETUP

< Frequency Range below 30MHz >

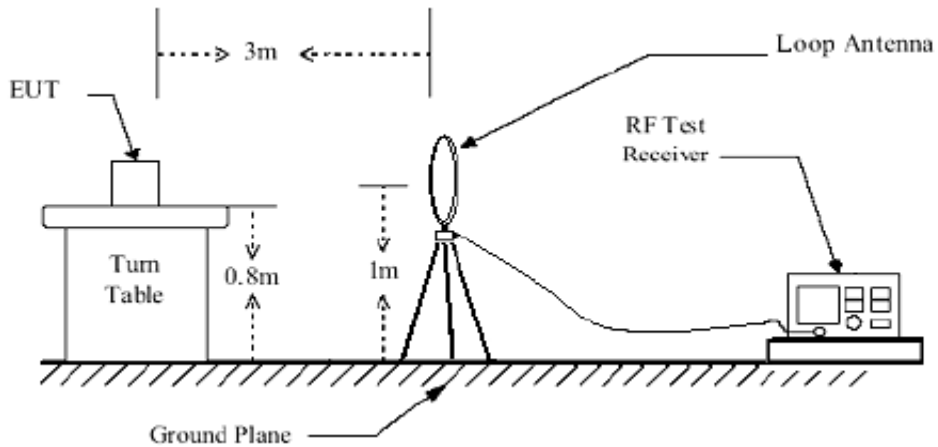

< Frequency Range 30MHz~1GHz >

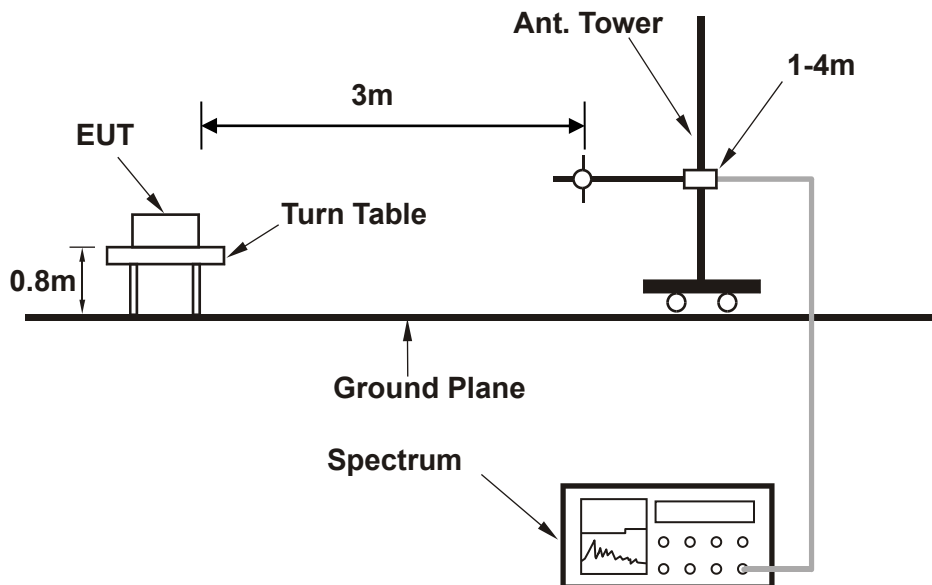



<Frequency Range above 1GHz>

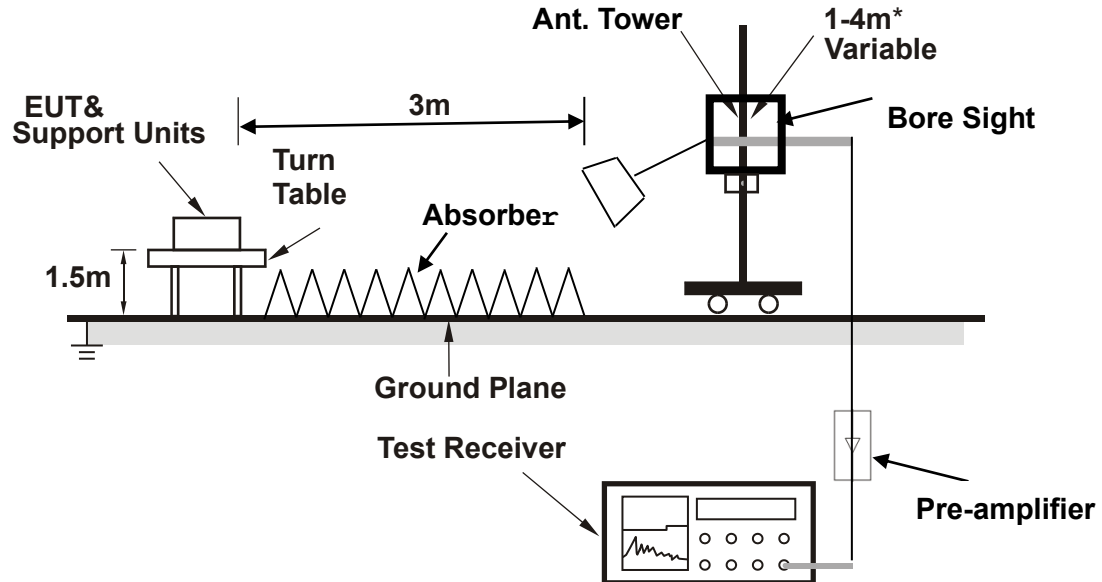

Note: Above 1G is a directional antenna

Depends on the EUT height and the antenna 3dB beamwidth both, refer to section 7.3 of CISPR 16-2-3.

For the actual test configuration, please refer to the attached file (Test Setup Photo).



3.6.5 TEST RESULTS

NOTE : The 9K~30MHz amplitude of spurious emissions attenuated more than 20 dB below the permissible value is not required in the report.

BELOW 1GHz WORST-CASE DATA

30 MHz – 1GHz data:

GSM 850:

CHANNEL BANDWIDTH: 128 ~ 251

MODE	TX channel 128	FREQUENCY RANGE	Below 1000MHz
ENVIRONMENTAL CONDITIONS	23deg. C, 70%RH	INPUT POWER	AC 120V/60HZ
TESTED BY	Jace Hu		

ANTENNA POLARITY & TEST DISTANCE: HORIZONTAL AT 3 M

Rg	Frequency [MHz]	PK+ Level [dBm]	PK+ Limit [dBm]	PK+ Margin [dB]	Correction [dB]	Polarization	Azimuth [deg]	Antenna Height [m]
1	37.275	-51.98	-13.00	38.98	3.47	H	359	1.00
1	84.805	-58.86	-13.00	45.86	-8.89	H	185	2.00
1	148.825	-59.89	-13.00	46.89	-11.22	H	304.6	2.00
1	230.790	-55.61	-13.00	42.61	5.01	H	172.6	1.00
1	463.105	-59.45	-13.00	46.45	5.65	H	65.5	2.00
1	683.780	-58.74	-13.00	45.74	5.18	H	125.3	2.00

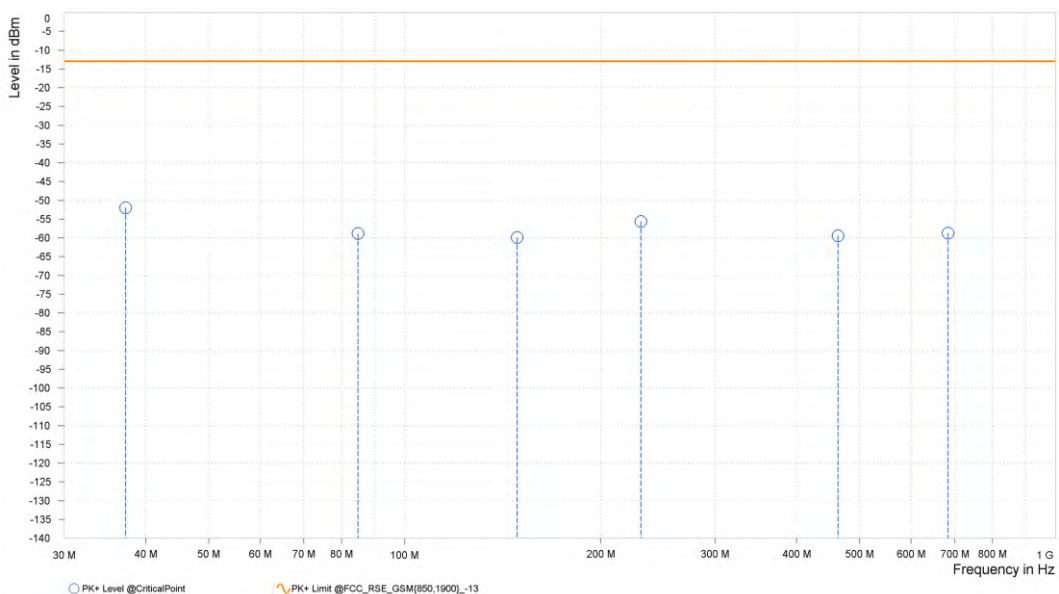



**BUREAU
VERITAS**

Test Report No.: PSU-NQN2403180115RF05

MODE	TX channel 128	FREQUENCY RANGE	Below 1000MHz
ENVIRONMENTAL CONDITIONS	23deg. C, 70%RH	INPUT POWER	AC 120V/60HZ
TESTED BY	Jace Hu		
ANTENNA POLARITY & TEST DISTANCE: VERTICAL AT 3 M			

Rg	Frequency [MHz]	PK+ Level [dBm]	PK+ Limit [dBm]	PK+ Margin [dB]	Correction [dB]	Polarization	Azimuth [deg]	Antenna Height [m]
1	44.550	-57.55	-13.00	44.55	-3.24	V	234.7	1.00
1	78.985	-53.19	-13.00	40.19	-7.21	V	114	1.00
1	98.870	-48.12	-13.00	35.12	8.58	V	127.6	2.00
1	280.260	-61.64	-13.00	48.64	2.48	V	65.4	2.00
1	439.825	-60.72	-13.00	47.72	5.99	V	234.7	1.00
1	590.660	-59.33	-13.00	46.33	5.26	V	175	1.00

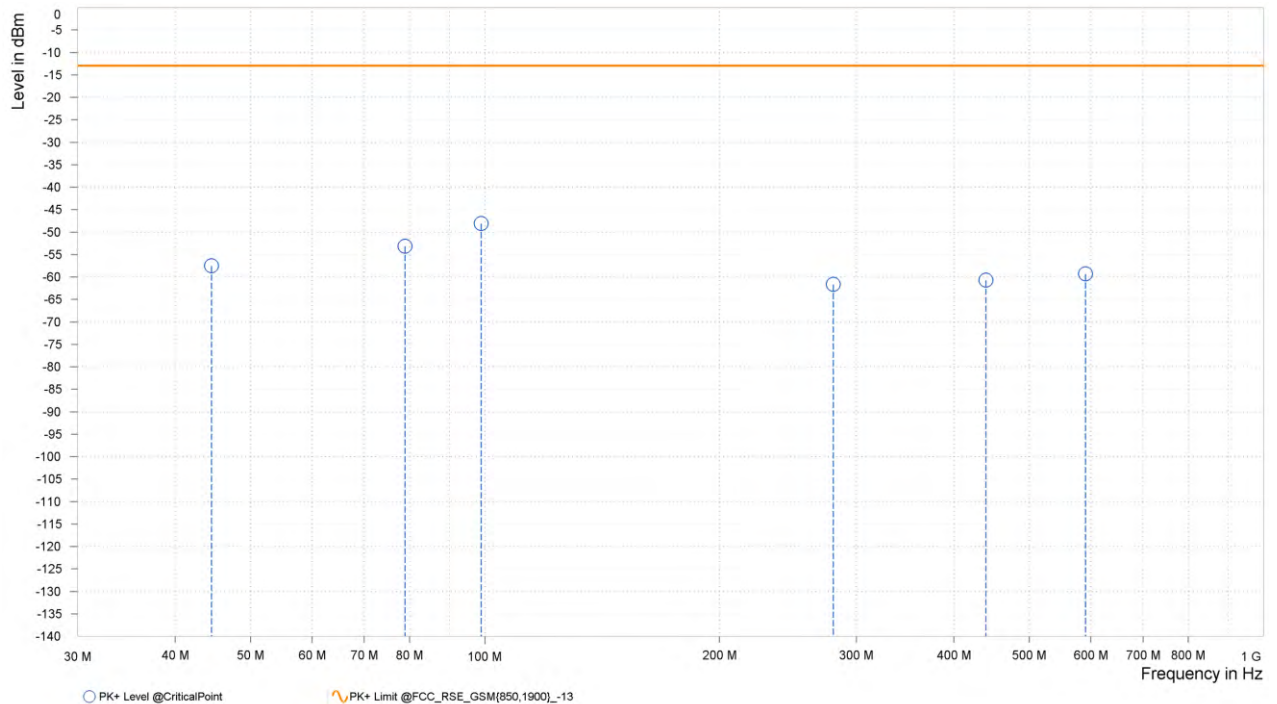



ABOVE 1GHz DATA

Note: For higher frequency, the emission is too low to be detected.

GSM 850

CH 128:

MODE	TX channel 128	FREQUENCY RANGE	Above 1000MHz
ENVIRONMENTAL CONDITIONS	23deg. C, 70%RH	INPUT POWER	AC 120V/60HZ
TESTED BY	Jace Hu		
ANTENNA POLARITY & TEST DISTANCE: HORIZONTAL AT 3 M			

Rg	Frequency [MHz]	PK+ Level [dBm]	PK+ Limit [dBm]	PK+ Margin [dB]	Correction [dB]	Polarization	Azimuth [deg]	Antenna Height [m]
2	1,648.400	-48.61	-13.00	35.61	15.93	H	87.7	1.00
3	2,472.000	-32.94	-13.00	19.94	20.69	H	160.6	1.00

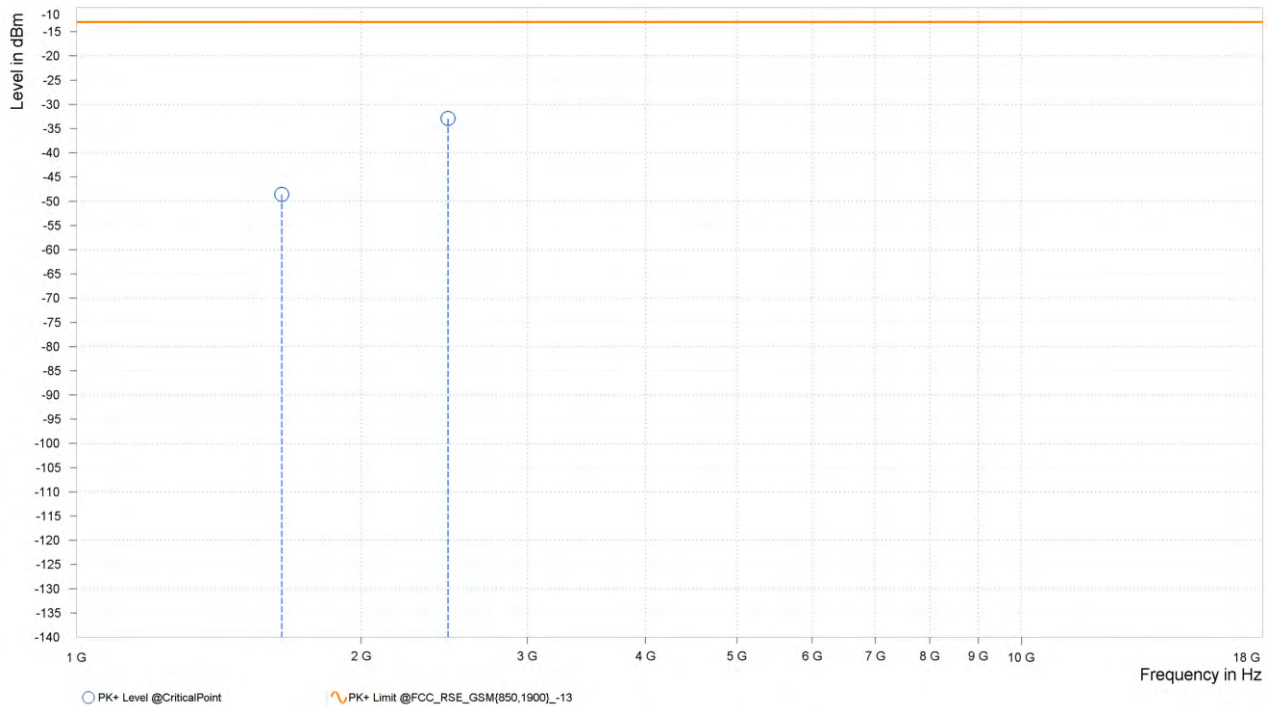



**BUREAU
VERITAS**

Test Report No.: PSU-NQN2403180115RF05

MODE	TX channel 128	FREQUENCY RANGE	Above 1000MHz
ENVIRONMENTAL CONDITIONS	23deg. C, 70%RH	INPUT POWER	AC 120V/60HZ
TESTED BY	Jace Hu		
ANTENNA POLARITY & TEST DISTANCE: VERTICAL AT 3 M			

Rg	Frequency [MHz]	PK+ Level [dBm]	PK+ Limit [dBm]	PK+ Margin [dB]	Correction [dB]	Polarization	Azimuth [deg]	Antenna Height [m]
2	1,648.400	-51.88	-13.00	38.88	15.51	V	359	2.00
3	2,472.000	-20.24	-13.00	7.24	20.94	V	163	1.00

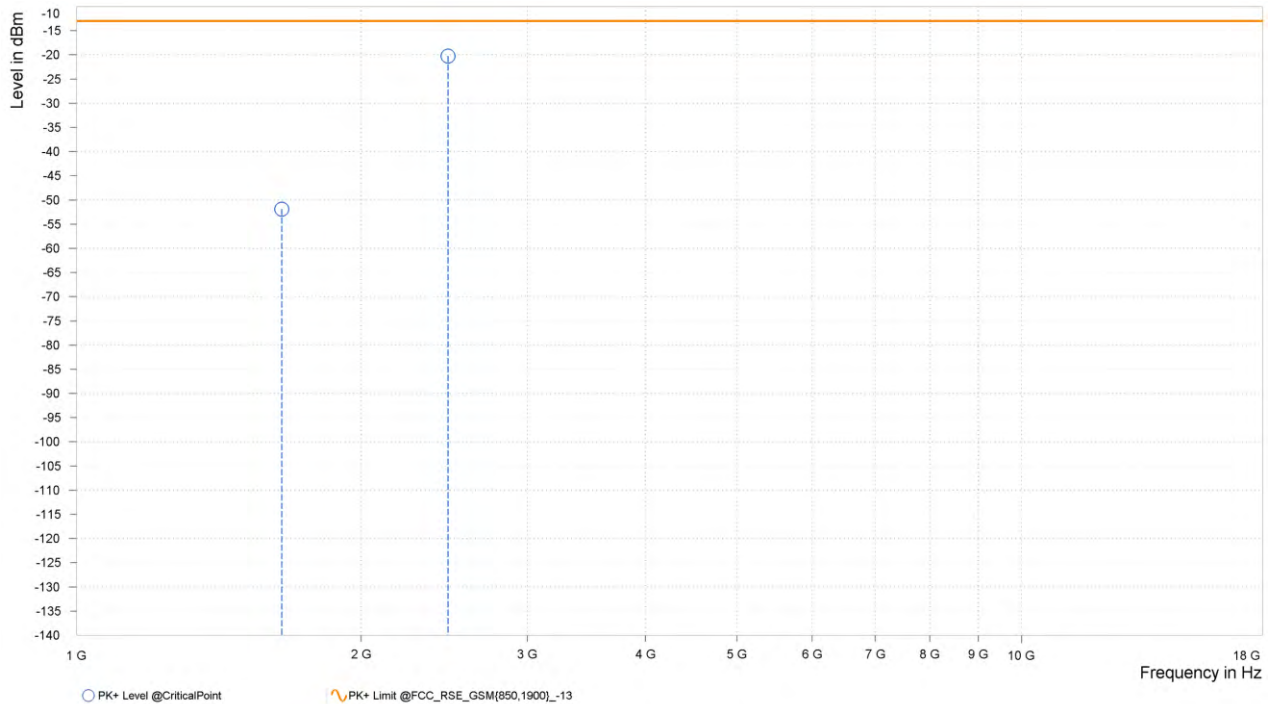



CH 189:

MODE	TX channel 189	FREQUENCY RANGE	Above 1000MHz
ENVIRONMENTAL CONDITIONS	23deg. C, 70%RH	INPUT POWER	AC 120V/60HZ
TESTED BY	Jace Hu		
ANTENNA POLARITY & TEST DISTANCE: HORIZONTAL AT 3 M			

Rg	Frequency [MHz]	PK+ Level [dBm]	PK+ Limit [dBm]	PK+ Margin [dB]	Correction [dB]	Polarization	Azimuth [deg]	Antenna Height [m]
2	1,673.000	-50.93	-13.00	37.93	16.68	H	1.3	2.00
3	2,509.000	-28.12	-13.00	15.12	21.00	H	163	1.00

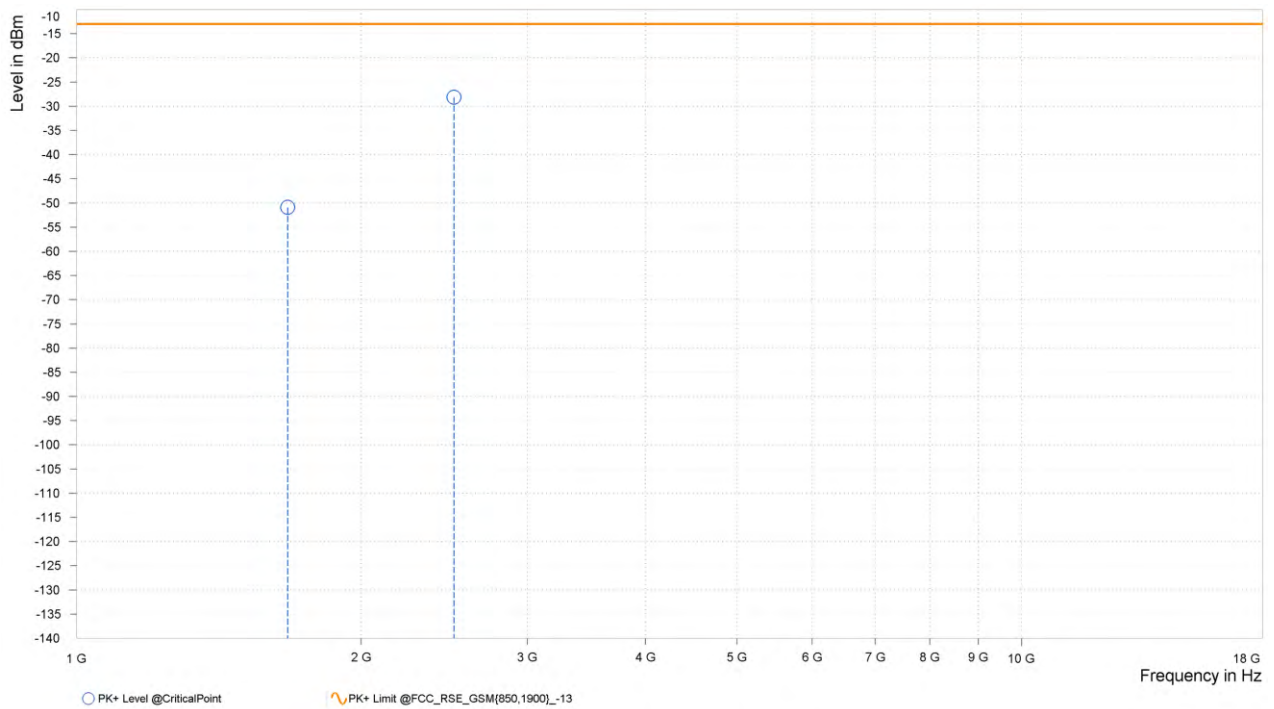



**BUREAU
VERITAS**

Test Report No.: PSU-NQN2403180115RF05

MODE	TX channel 189	FREQUENCY RANGE	Above 1000MHz
ENVIRONMENTAL CONDITIONS	23deg. C, 70%RH	INPUT POWER	AC 120V/60HZ
TESTED BY	Jace Hu		
ANTENNA POLARITY & TEST DISTANCE: VERTICAL AT 3 M			

Rg	Frequency [MHz]	PK+ Level [dBm]	PK+ Limit [dBm]	PK+ Margin [dB]	Correction [dB]	Polarization	Azimuth [deg]	Antenna Height [m]
2	1,673.000	-51.79	-13.00	38.79	15.57	V	274.7	2.00
3	2,509.500	-27.89	-13.00	14.89	21.61	V	160.6	1.00

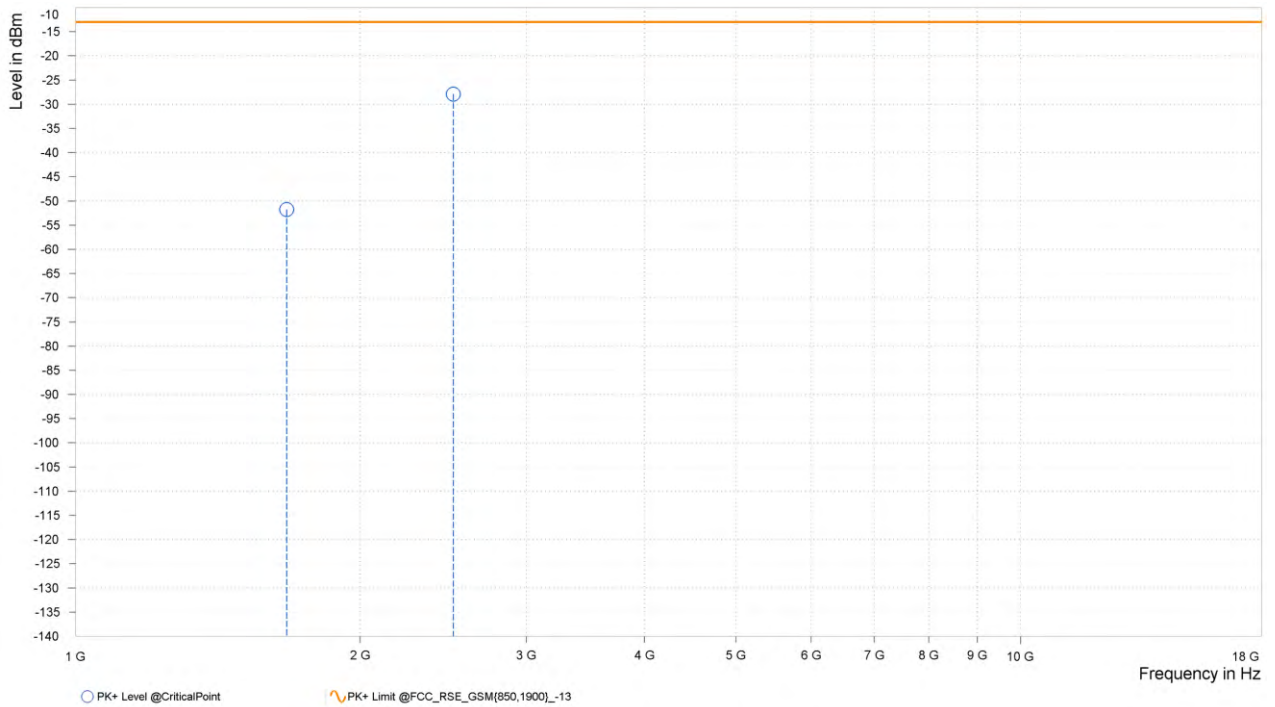



**BUREAU
VERITAS**

Test Report No.: PSU-NQN2403180115RF05

CH 251:

MODE	TX channel 251	FREQUENCY RANGE	Above 1000MHz
ENVIRONMENTAL CONDITIONS	23deg. C, 70%RH	INPUT POWER	AC 120V/60HZ
TESTED BY	Jace Hu		
ANTENNA POLARITY & TEST DISTANCE: HORIZONTAL AT 3 M			

Rg	Frequency [MHz]	PK+ Level [dBm]	PK+ Limit [dBm]	PK+ Margin [dB]	Correction [dB]	Polarization	Azimuth [deg]	Antenna Height [m]
2	1,698.000	-47.52	-13.00	34.52	17.07	H	87.7	1.00
3	2,546.000	-30.12	-13.00	17.12	20.93	H	199.4	2.00

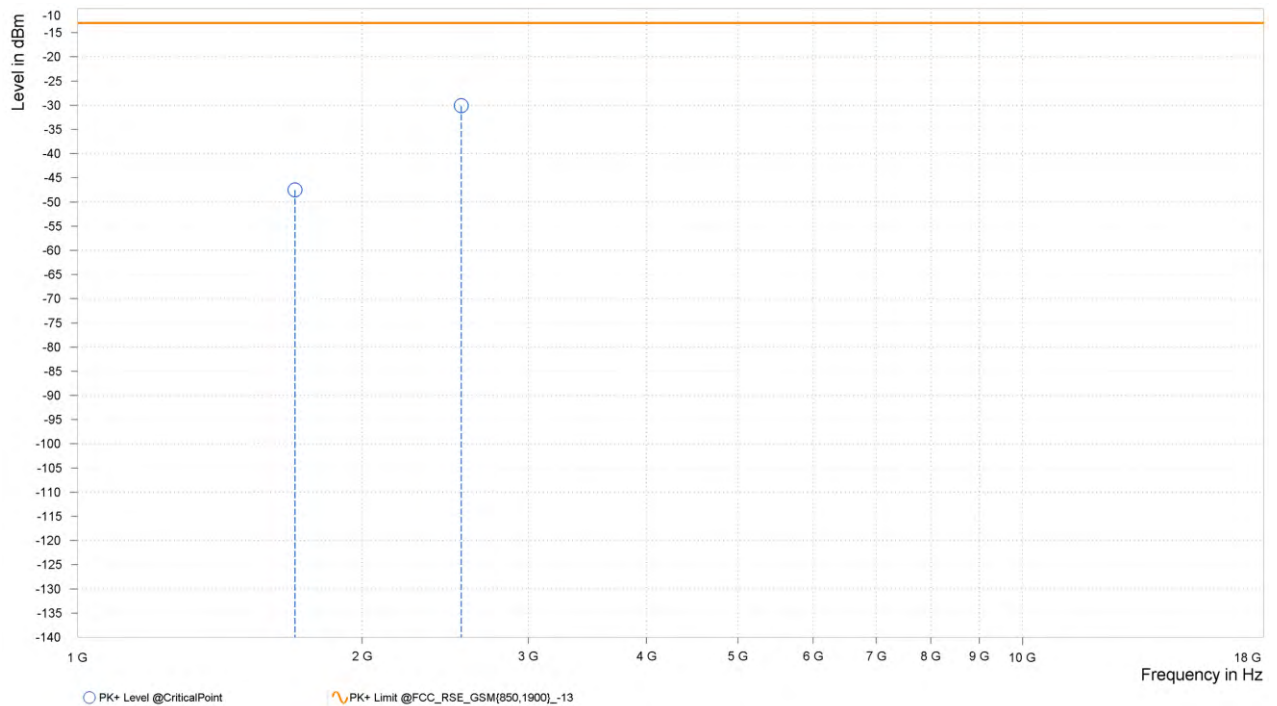



**BUREAU
VERITAS**

Test Report No.: PSU-NQN2403180115RF05

MODE	TX channel 251	FREQUENCY RANGE	Above 1000MHz
ENVIRONMENTAL CONDITIONS	23deg. C, 70%RH	INPUT POWER	AC 120V/60HZ
TESTED BY	Jace Hu		
ANTENNA POLARITY & TEST DISTANCE: VERTICAL AT 3 M			

Rg	Frequency [MHz]	PK+ Level [dBm]	PK+ Limit [dBm]	PK+ Margin [dB]	Correction [dB]	Polarization	Azimuth [deg]	Antenna Height [m]
2	1,698.000	-52.43	-13.00	39.43	16.31	V	359	2.00
3	2,546.500	-20.29	-13.00	7.29	21.56	V	161.8	1.00

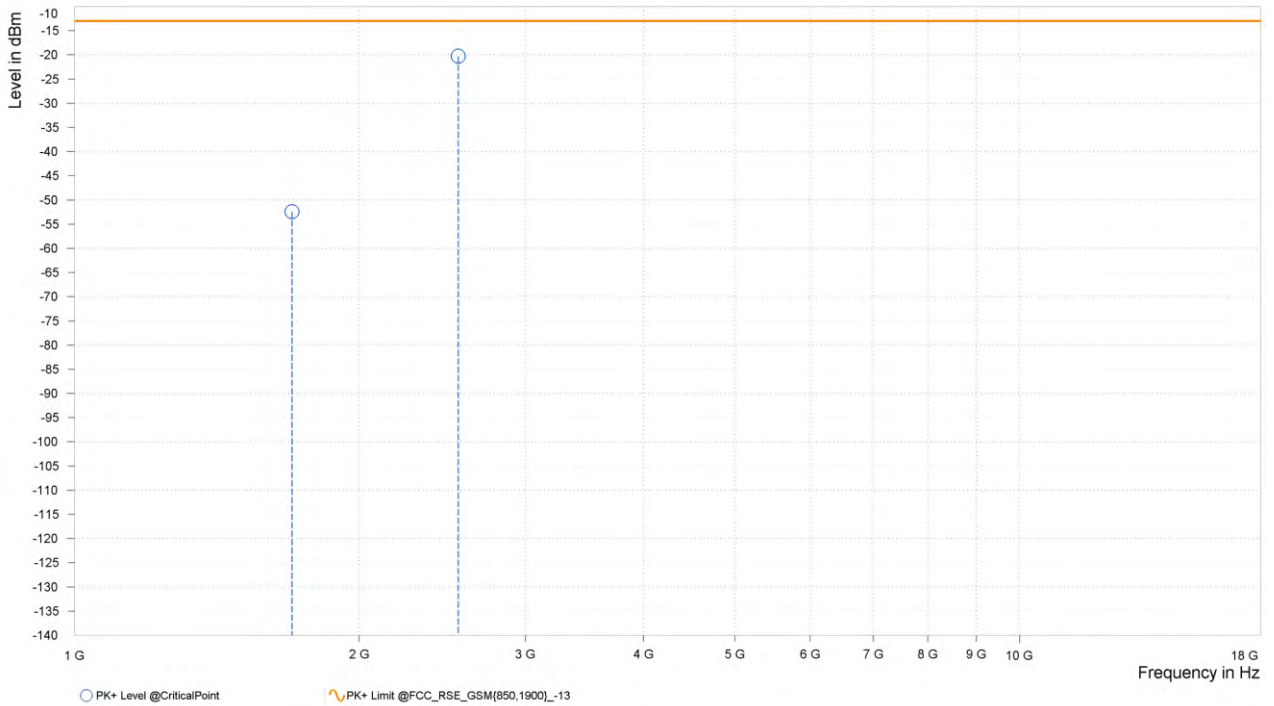



EDGE 850:

CH 128:

MODE	TX channel 128	FREQUENCY RANGE	Above 1000MHz
ENVIRONMENTAL CONDITIONS	23deg. C, 70%RH	INPUT POWER	AC 120V/60HZ
TESTED BY	Jace Hu		
ANTENNA POLARITY & TEST DISTANCE: HORIZONTAL AT 3 M			

Rg	Frequency [MHz]	PK+ Level [dBm]	PK+ Limit [dBm]	PK+ Margin [dB]	Correction [dB]	Polarization	Azimuth [deg]	Antenna Height [m]
2	1,648.400	-51.87	-13.00	38.87	15.93	H	1.4	2.00
3	2,471.500	-34.48	-13.00	21.48	20.69	H	198.1	2.00

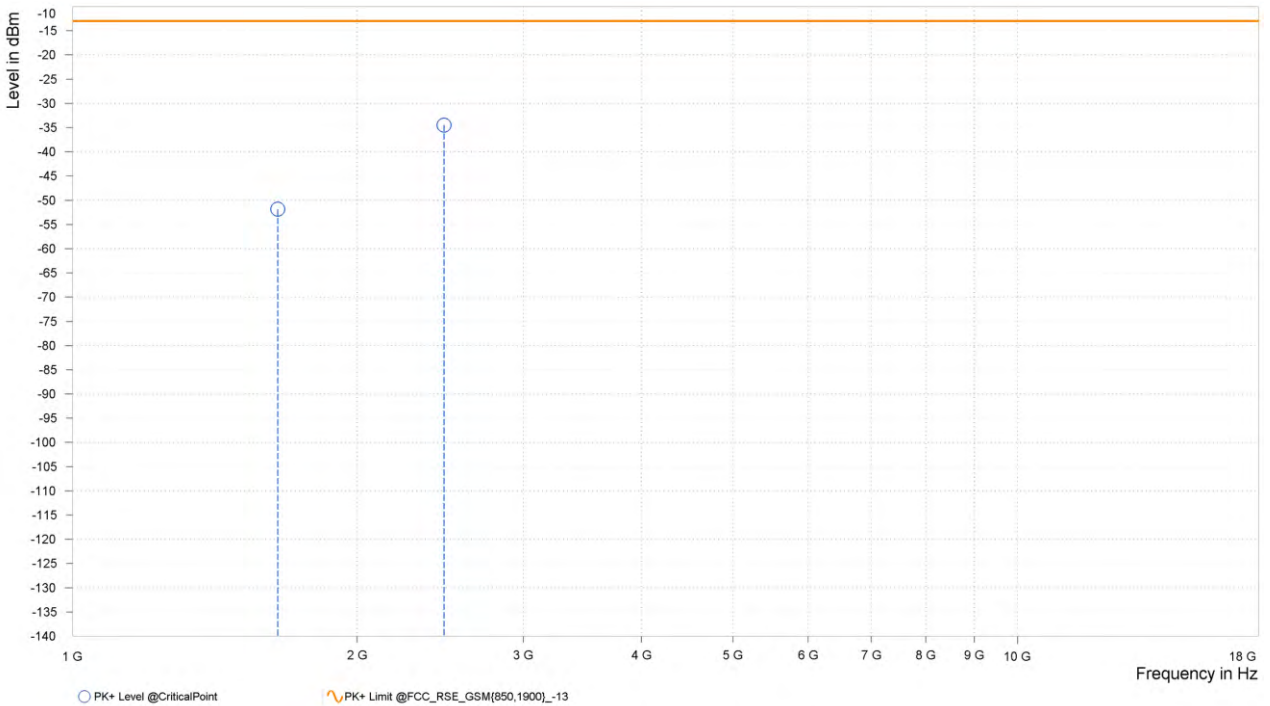



**BUREAU
VERITAS**

Test Report No.: PSU-NQN2403180115RF05

MODE	TX channel 128	FREQUENCY RANGE	Above 1000MHz
ENVIRONMENTAL CONDITIONS	23deg. C, 70%RH	INPUT POWER	AC 120V/60HZ
TESTED BY	Jace Hu		
ANTENNA POLARITY & TEST DISTANCE: VERTICAL AT 3 M			

Rg	Frequency [MHz]	PK+ Level [dBm]	PK+ Limit [dBm]	PK+ Margin [dB]	Correction [dB]	Polarization	Azimuth [deg]	Antenna Height [m]
2	1,648.400	-50.81	-13.00	37.81	15.51	V	1.4	2.00
3	2,472.000	-20.67	-13.00	7.67	20.94	V	163	1.00

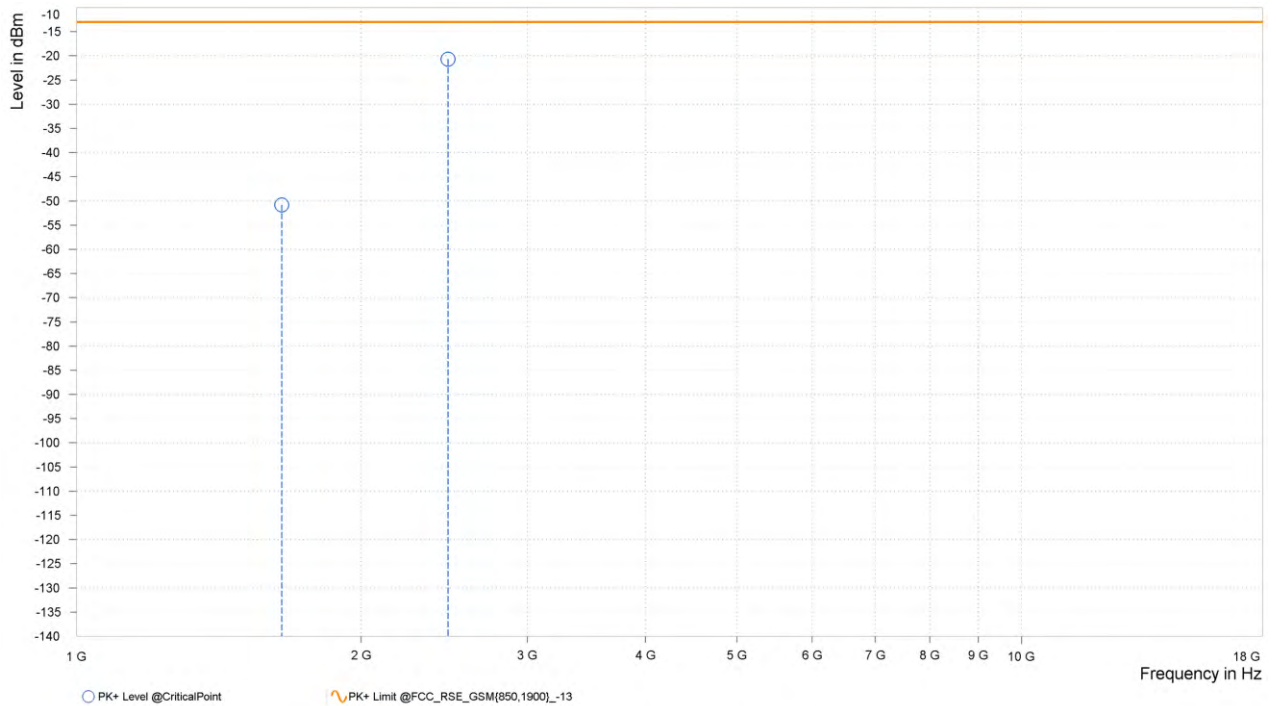



CH 189:

MODE	TX channel 189	FREQUENCY RANGE	Above 1000MHz
ENVIRONMENTAL CONDITIONS	23deg. C, 70%RH	INPUT POWER	AC 120V/60HZ
TESTED BY	Jace Hu		
ANTENNA POLARITY & TEST DISTANCE: HORIZONTAL AT 3 M			

Rg	Frequency [MHz]	PK+ Level [dBm]	PK+ Limit [dBm]	PK+ Margin [dB]	Correction [dB]	Polarization	Azimuth [deg]	Antenna Height [m]
2	1,673.000	-51.66	-13.00	38.66	16.68	H	88.9	1.00
3	2,508.500	-41.12	-13.00	28.12	21.01	H	359	2.00

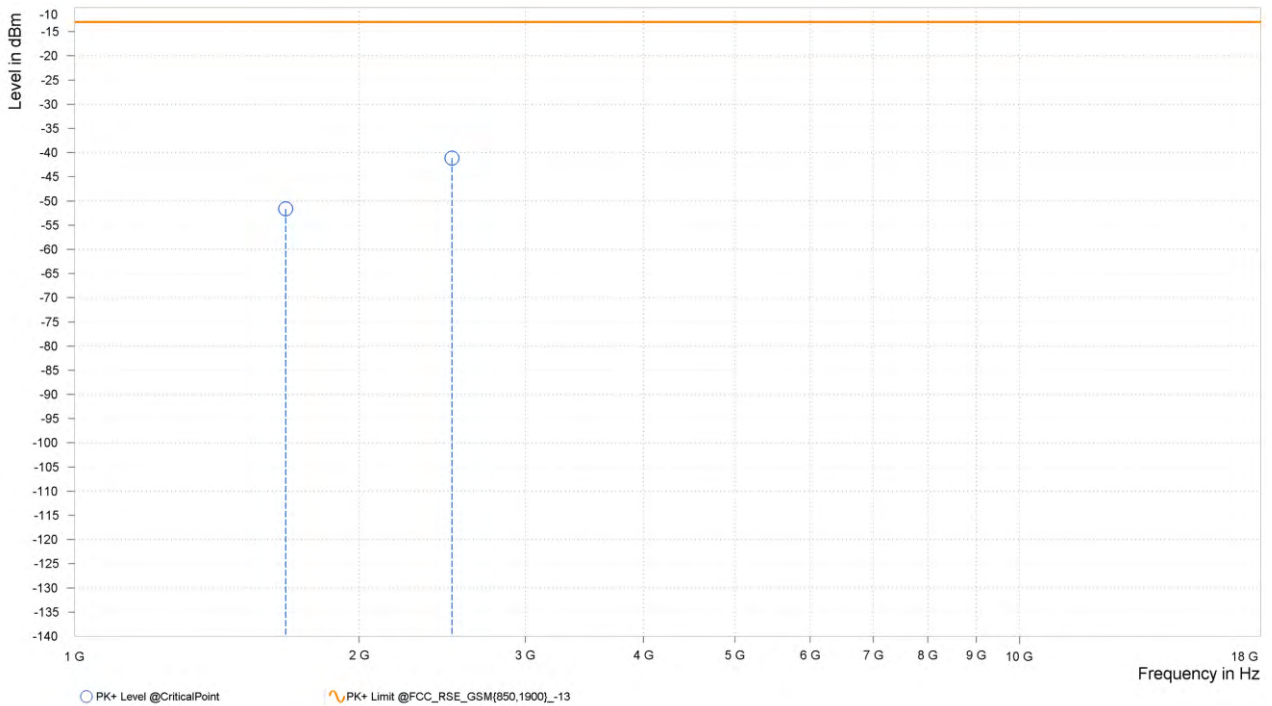



MODE	TX channel 189	FREQUENCY RANGE	Above 1000MHz
ENVIRONMENTAL CONDITIONS	23deg. C, 70%RH	INPUT POWER	AC 120V/60HZ
TESTED BY	Jace Hu		
ANTENNA POLARITY & TEST DISTANCE: VERTICAL AT 3 M			

Rg	Frequency [MHz]	PK+ Level [dBm]	PK+ Limit [dBm]	PK+ Margin [dB]	Correction [dB]	Polarization	Azimuth [deg]	Antenna Height [m]
2	1,673.000	-52.48	-13.00	39.48	15.57	V	358.6	1.00
3	2,509.000	-26.87	-13.00	13.87	21.61	V	0.9	2.00

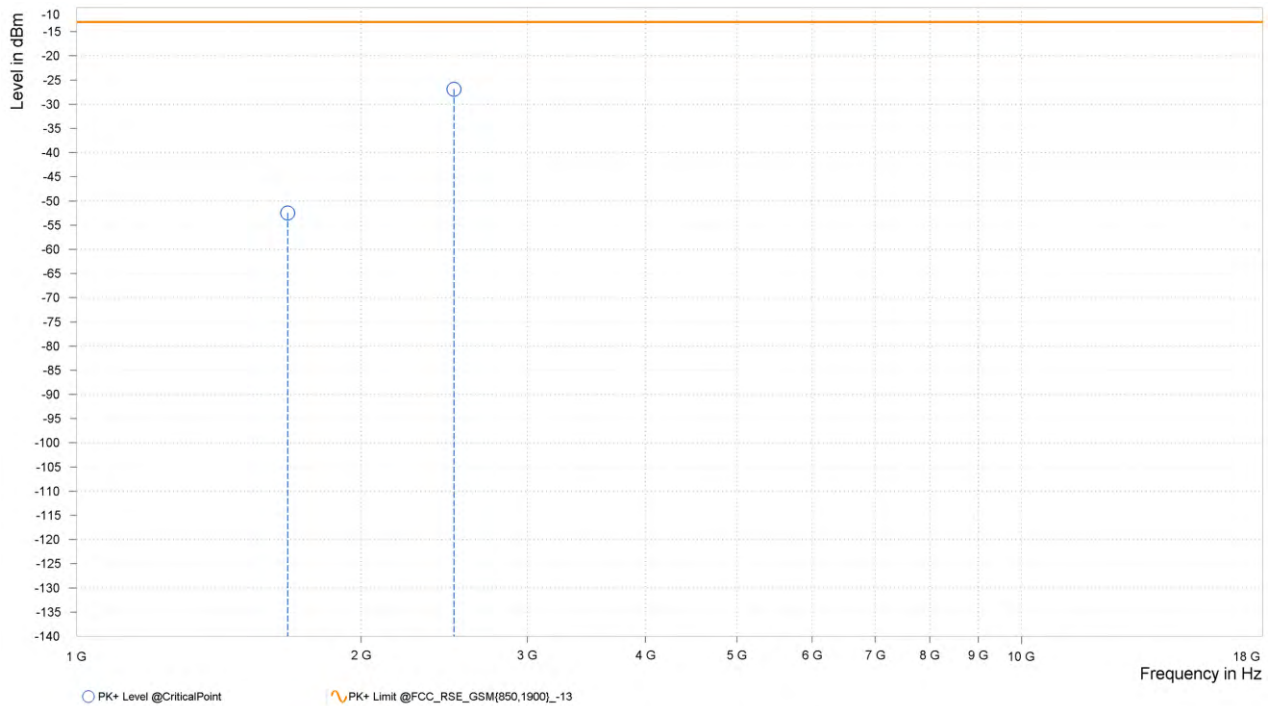



CH 251:

MODE	TX channel 251	FREQUENCY RANGE	Above 1000MHz
ENVIRONMENTAL CONDITIONS	23deg. C, 70%RH	INPUT POWER	AC 120V/60HZ
TESTED BY	Jace Hu		
ANTENNA POLARITY & TEST DISTANCE: HORIZONTAL AT 3 M			

Rg	Frequency [MHz]	PK+ Level [dBm]	PK+ Limit [dBm]	PK+ Margin [dB]	Correction [dB]	Polarization	Azimuth [deg]	Antenna Height [m]
2	1,652.800	-55.75	-13.00	42.75	14.29	H	304.5	2.00
3	2,479.200	-51.25	-13.00	38.25	19.47	H	1	1.00

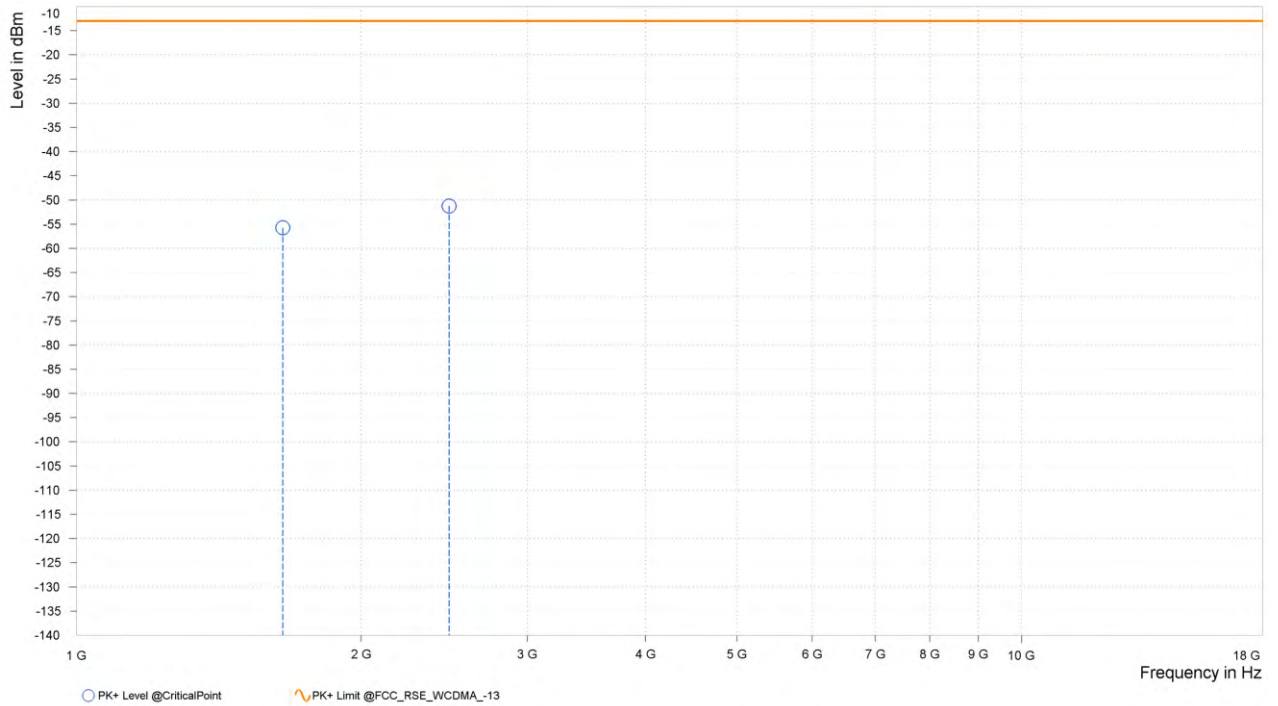



MODE	TX channel 251	FREQUENCY RANGE	Above 1000MHz
ENVIRONMENTAL CONDITIONS	23deg. C, 70%RH	INPUT POWER	AC 120V/60HZ
TESTED BY	Jace Hu		
ANTENNA POLARITY & TEST DISTANCE: VERTICAL AT 3 M			

Rg	Frequency [MHz]	PK+ Level [dBm]	PK+ Limit [dBm]	PK+ Margin [dB]	Correction [dB]	Polarization	Azimuth [deg]	Antenna Height [m]
2	1,652.800	-56.56	-13.00	43.56	13.58	V	345.9	1.00
3	2,479.200	-49.22	-13.00	36.22	19.71	V	359	2.00

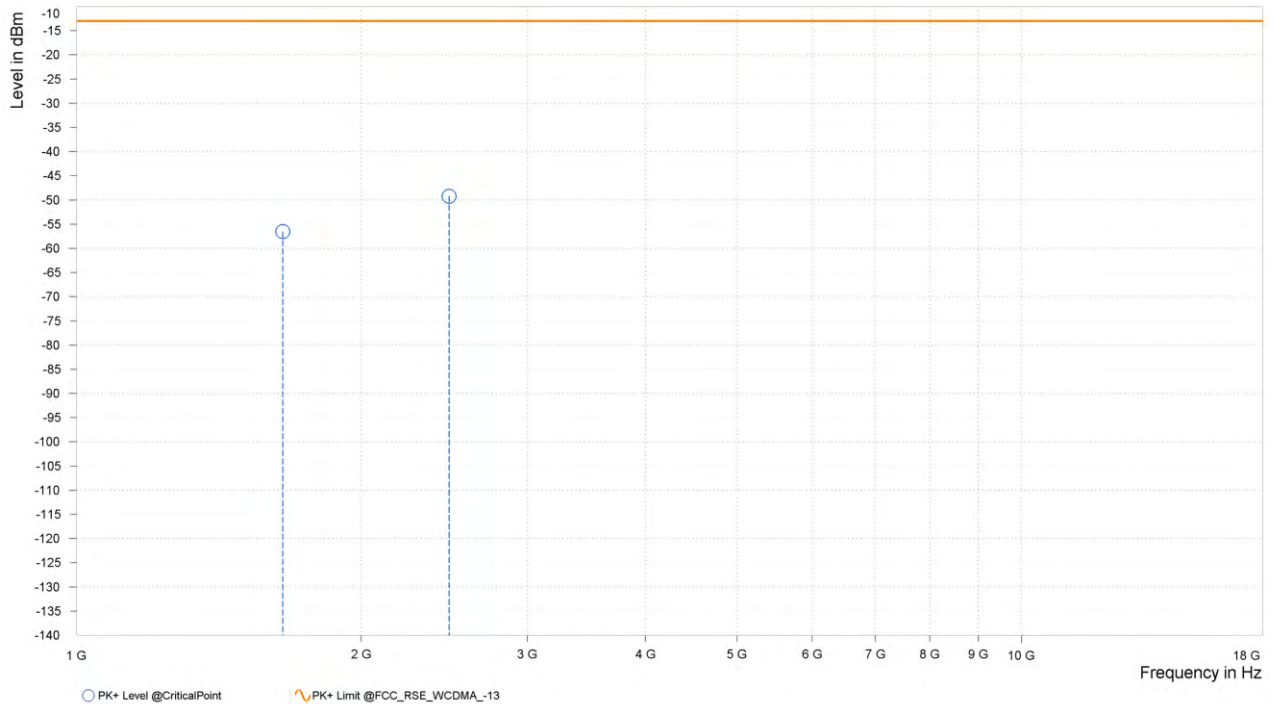



WCDMA Band V:

CH 4132:

MODE	TX channel 4132	FREQUENCY RANGE	Above 1000MHz
ENVIRONMENTAL CONDITIONS	23deg. C, 70%RH	INPUT POWER	AC 120V/60HZ
TESTED BY	Jace Hu		
ANTENNA POLARITY & TEST DISTANCE: HORIZONTAL AT 3 M			

Rg	Frequency [MHz]	PK+ Level [dBm]	PK+ Limit [dBm]	PK+ Margin [dB]	Correction [dB]	Polarization	Azimuth [deg]	Antenna Height [m]
2	1,672.800	-53.68	-13.00	40.68	14.80	H	1	2.00
3	2,509.200	-50.02	-13.00	37.02	19.71	H	222	2.00

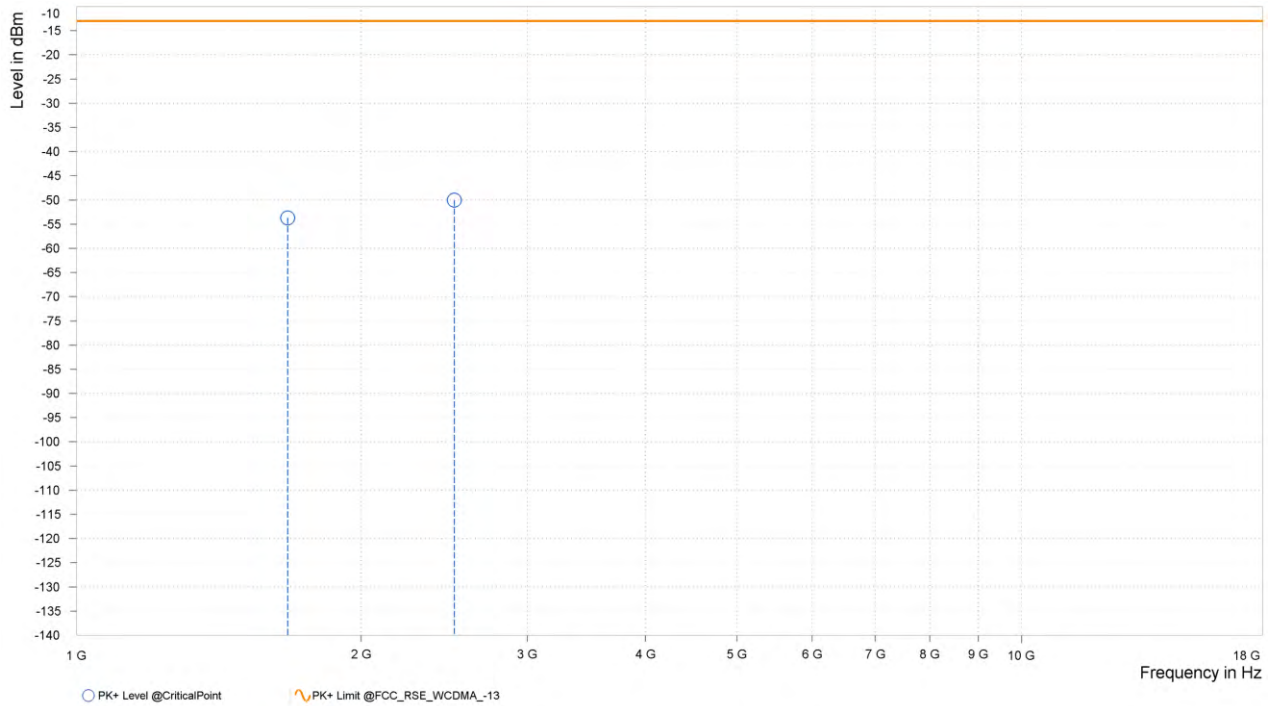



MODE	TX channel 4132	FREQUENCY RANGE	Above 1000MHz
ENVIRONMENTAL CONDITIONS	23deg. C, 70%RH	INPUT POWER	AC 120V/60HZ
TESTED BY	Jace Hu		
ANTENNA POLARITY & TEST DISTANCE: VERTICAL AT 3 M			

Rg	Frequency [MHz]	PK+ Level [dBm]	PK+ Limit [dBm]	PK+ Margin [dB]	Correction [dB]	Polarization	Azimuth [deg]	Antenna Height [m]
2	1,672.800	-56.45	-13.00	43.45	13.69	V	298.6	2.00
3	2,509.200	-49.16	-13.00	36.16	20.32	V	344.6	1.00

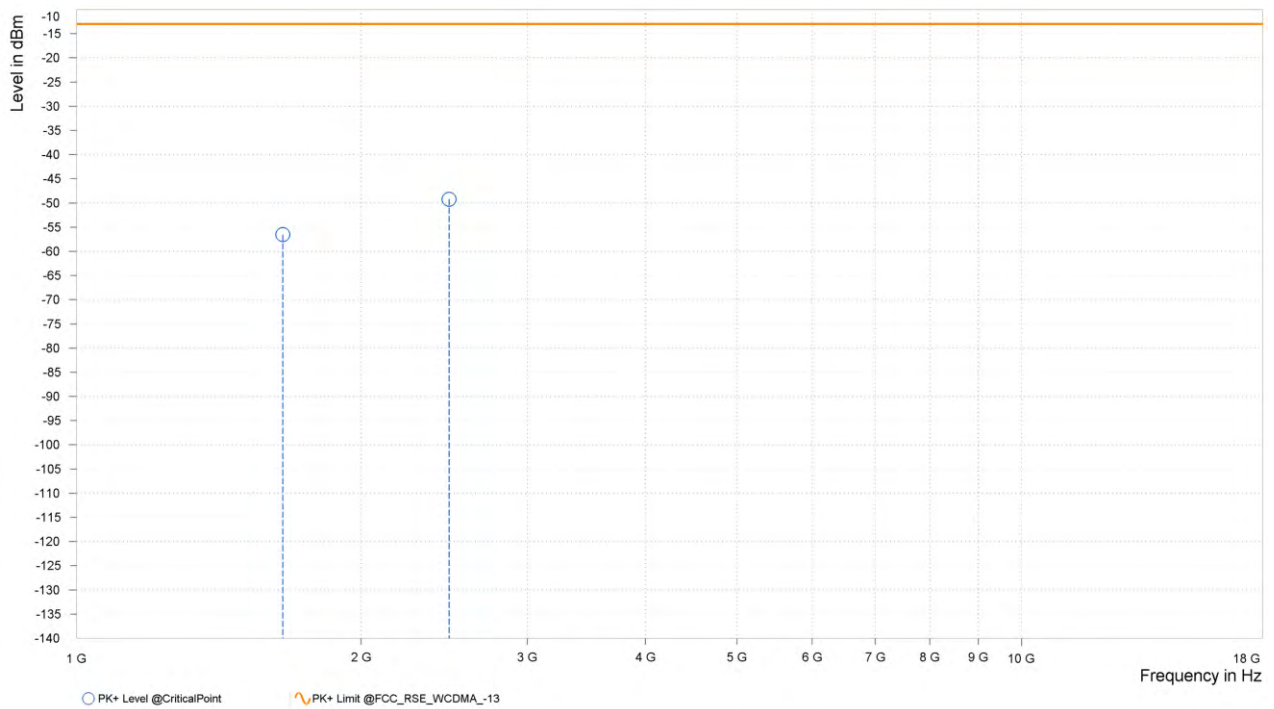



CH 4182:

MODE	TX channel 4182	FREQUENCY RANGE	Above 1000MHz
ENVIRONMENTAL CONDITIONS	23deg. C, 70%RH	INPUT POWER	AC 120V/60HZ
TESTED BY	Jace Hu		
ANTENNA POLARITY & TEST DISTANCE: HORIZONTAL AT 3 M			

Rg	Frequency [MHz]	PK+ Level [dBm]	PK+ Limit [dBm]	PK+ Margin [dB]	Correction [dB]	Polarization	Azimuth [deg]	Antenna Height [m]
2	1,672.800	-53.68	-13.00	40.68	14.80	H	1	2.00
3	2,509.200	-50.02	-13.00	37.02	19.71	H	222	2.00

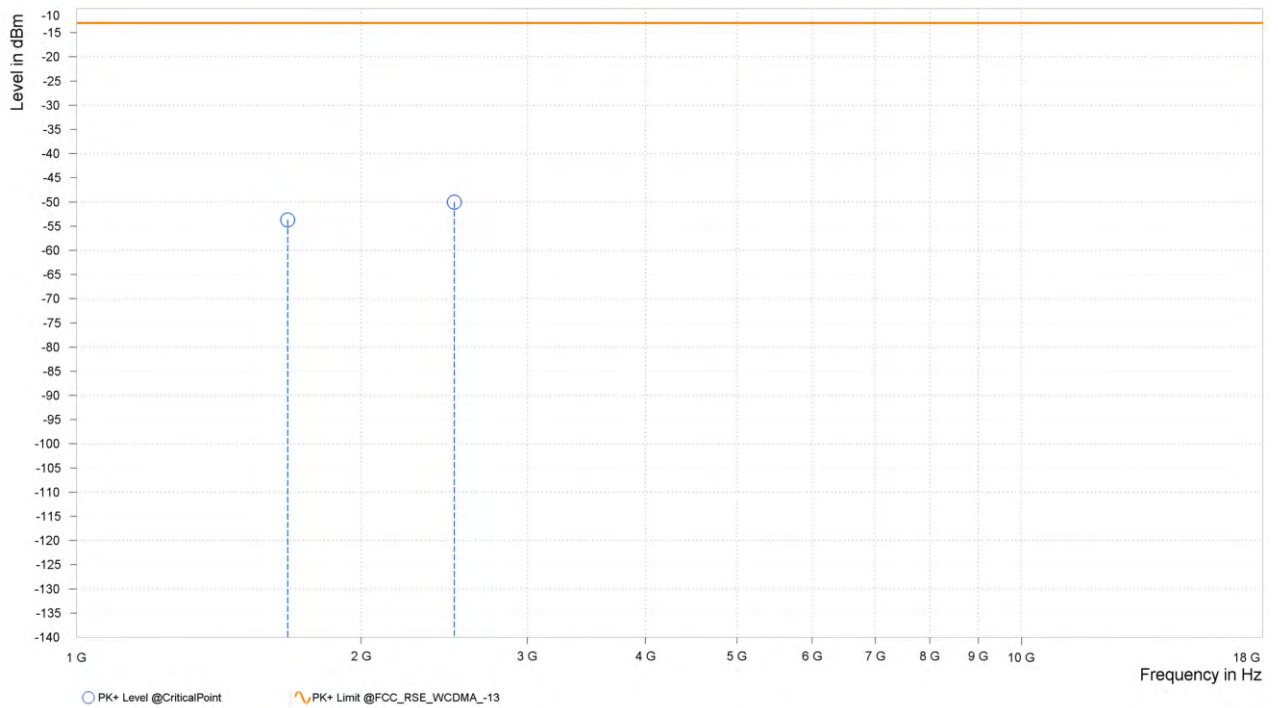



MODE	TX channel 4182	FREQUENCY RANGE	Above 1000MHz
ENVIRONMENTAL CONDITIONS	23deg. C, 70%RH	INPUT POWER	AC 120V/60HZ
TESTED BY	Jace Hu		
ANTENNA POLARITY & TEST DISTANCE: VERTICAL AT 3 M			

Rg	Frequency [MHz]	PK+ Level [dBm]	PK+ Limit [dBm]	PK+ Margin [dB]	Correction [dB]	Polarization	Azimuth [deg]	Antenna Height [m]
2	1,672.800	-56.45	-13.00	43.45	13.69	V	298.6	2.00
3	2,509.200	-49.16	-13.00	36.16	20.32	V	344.6	1.00

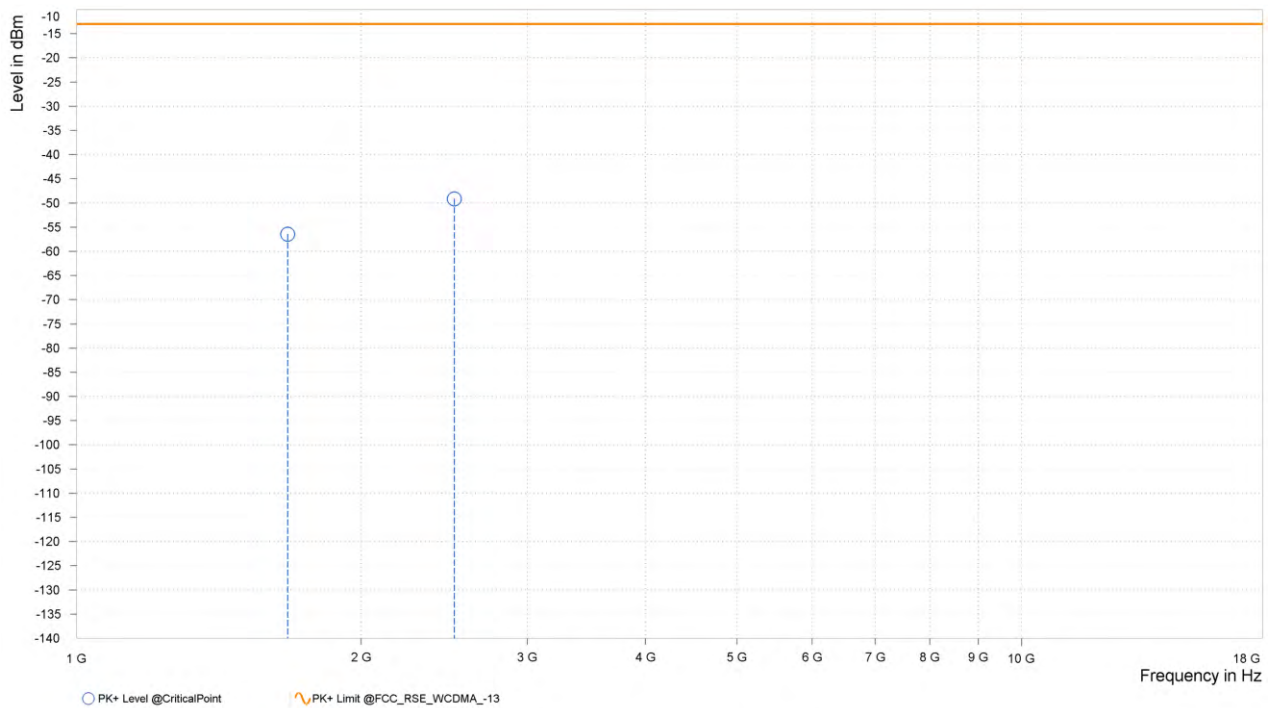



CH 4233:

MODE	TX channel 4233	FREQUENCY RANGE	Above 1000MHz
ENVIRONMENTAL CONDITIONS	23deg. C, 70%RH	INPUT POWER	AC 120V/60HZ
TESTED BY	Jace Hu		
ANTENNA POLARITY & TEST DISTANCE: HORIZONTAL AT 3 M			

Rg	Frequency [MHz]	PK+ Level [dBm]	PK+ Limit [dBm]	PK+ Margin [dB]	Correction [dB]	Polarization	Azimuth [deg]	Antenna Height [m]
2	1,693.200	-54.09	-13.00	41.09	15.16	H	312.5	1.00
3	2,539.800	-51.63	-13.00	38.63	19.36	H	328	1.00

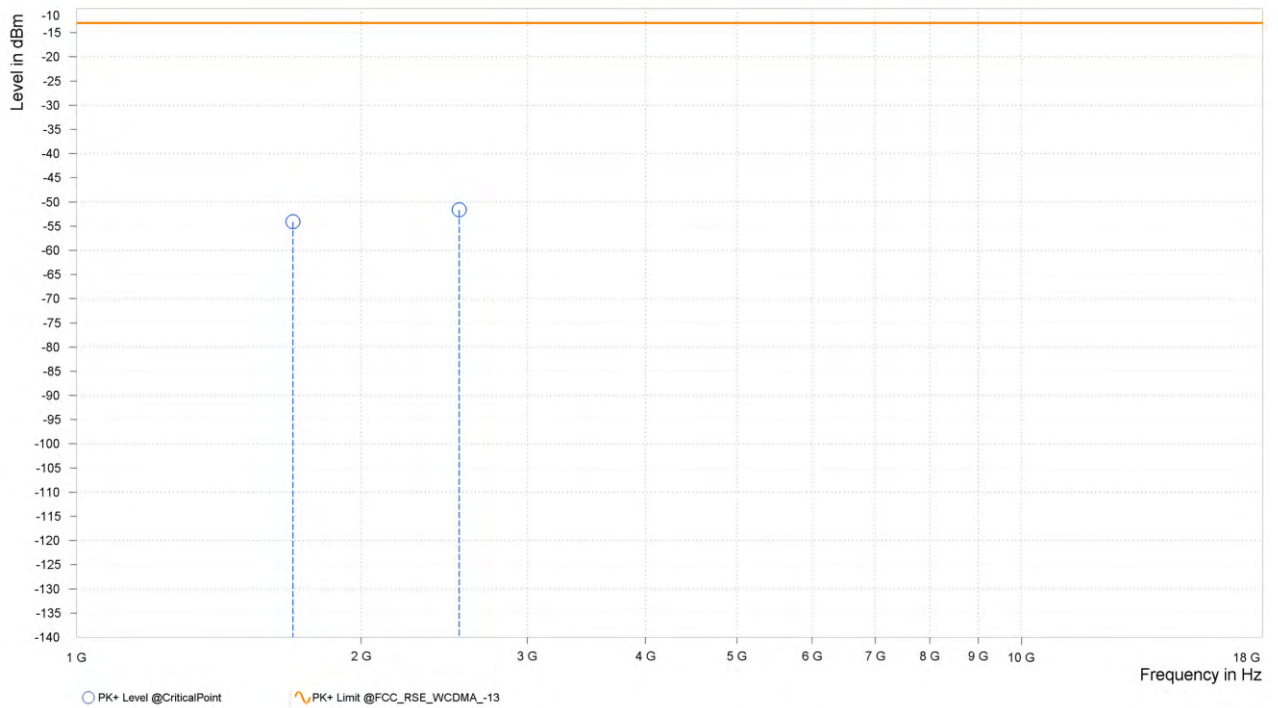



MODE	TX channel 4233	FREQUENCY RANGE	Above 1000MHz
ENVIRONMENTAL CONDITIONS	23deg. C, 70%RH	INPUT POWER	AC 120V/60HZ
TESTED BY	Jace Hu		
ANTENNA POLARITY & TEST DISTANCE: VERTICAL AT 3 M			

Rg	Frequency [MHz]	PK+ Level [dBm]	PK+ Limit [dBm]	PK+ Margin [dB]	Correction [dB]	Polarization	Azimuth [deg]	Antenna Height [m]
2	1,693.200	-53.44	-13.00	40.44	14.18	V	316.1	1.00
3	2,539.800	-50.70	-13.00	37.70	20.05	V	1	2.00

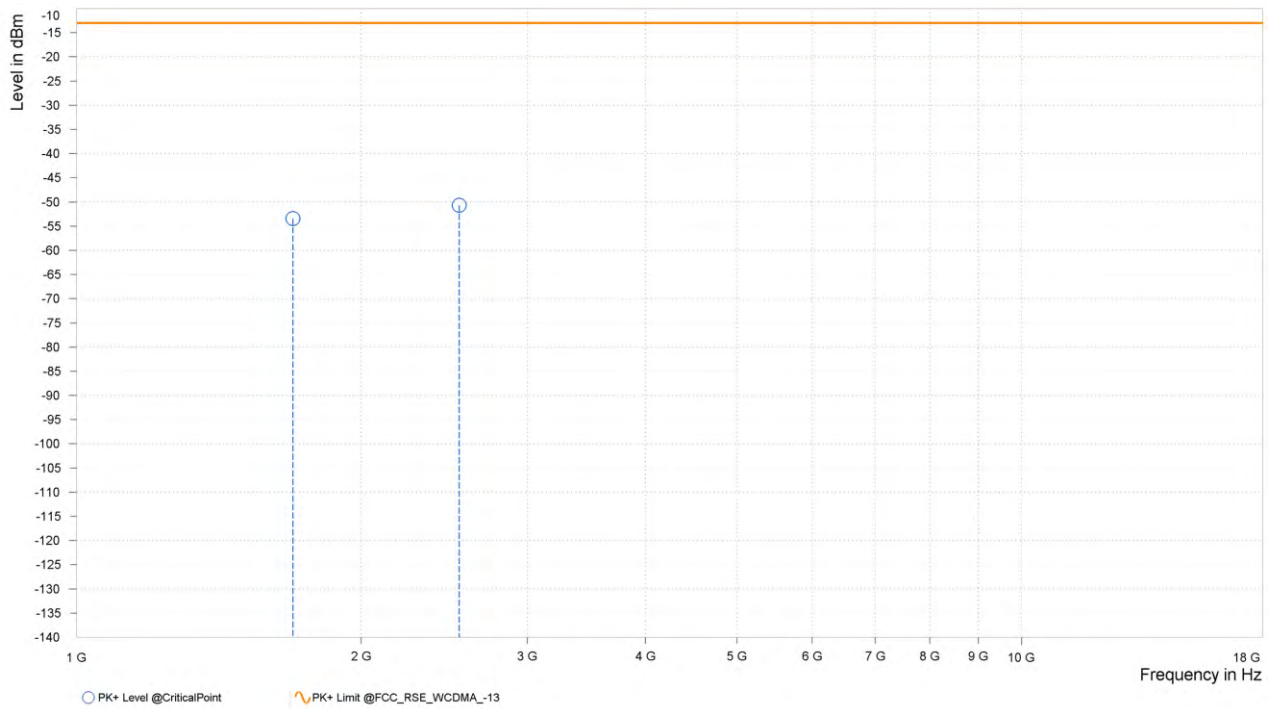



LTE Band 26

CHANNEL BANDWIDTH: 1.4MHz / QPSK

CH26915

MODE	TX channel 26915	FREQUENCY RANGE	Above 1000MHz
ENVIRONMENTAL CONDITIONS	23deg. C, 70%RH	INPUT POWER	AC 120V/60HZ
TESTED BY	Jace Hu		
ANTENNA POLARITY & TEST DISTANCE: HORIZONTAL AT 3 M			

Rg	Frequency [MHz]	PK+ Level [dBm]	PK+ Limit [dBm]	PK+ Margin [dB]	Correction [dB]	Polarization	Azimuth [deg]	Antenna Height [m]
2	1,671.740	-54.25	-13.00	41.25	14.79	H	55.5	1.00
3	2,507.610	-50.64	-13.00	37.64	19.73	H	251.8	2.00

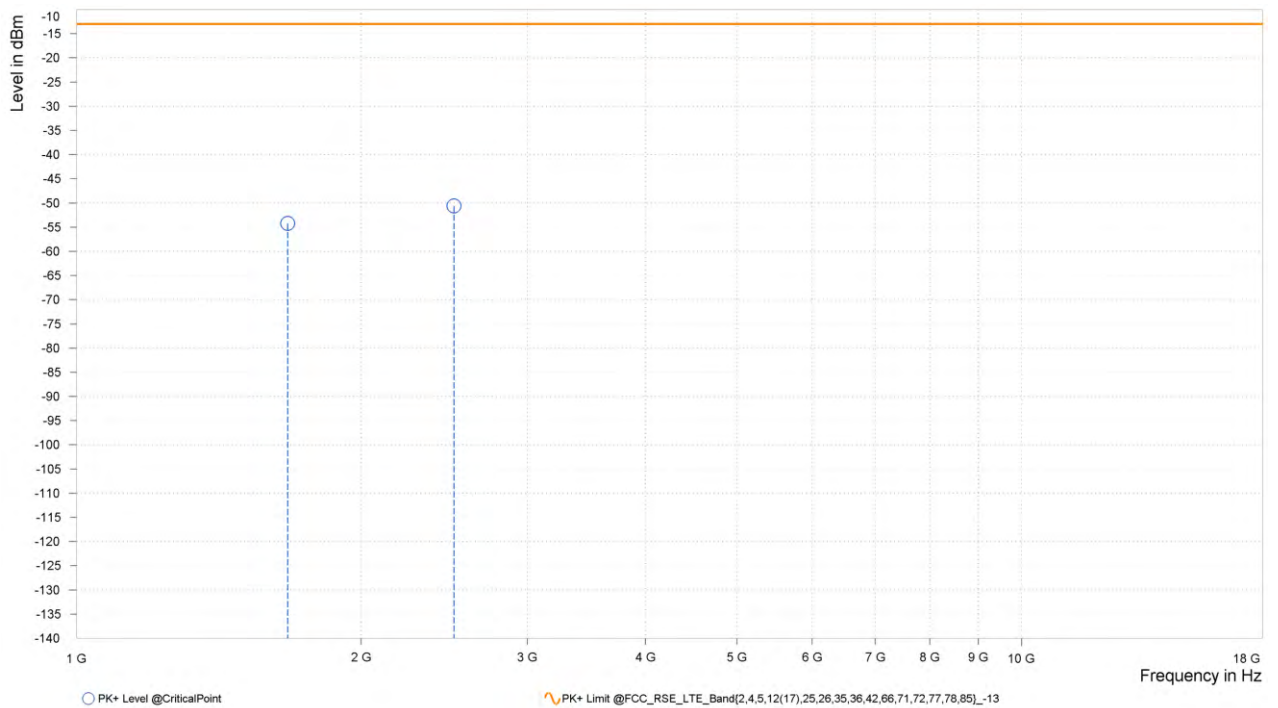



**BUREAU
VERITAS**

Test Report No.: PSU-NQN2403180115RF05

MODE	TX channel 26915	FREQUENCY RANGE	Above 1000MHz
ENVIRONMENTAL CONDITIONS	23deg. C, 70%RH	INPUT POWER	AC 120V/60HZ
TESTED BY	Jace Hu		
ANTENNA POLARITY & TEST DISTANCE: VERTICAL AT 3 M			

Rg	Frequency [MHz]	PK+ Level [dBm]	PK+ Limit [dBm]	PK+ Margin [dB]	Correction [dB]	Polarization	Azimuth [deg]	Antenna Height [m]
2	1,671.740	-55.58	-13.00	42.58	13.68	V	299.8	2.00
3	2,507.610	-48.84	-13.00	35.84	20.30	V	0.9	2.00

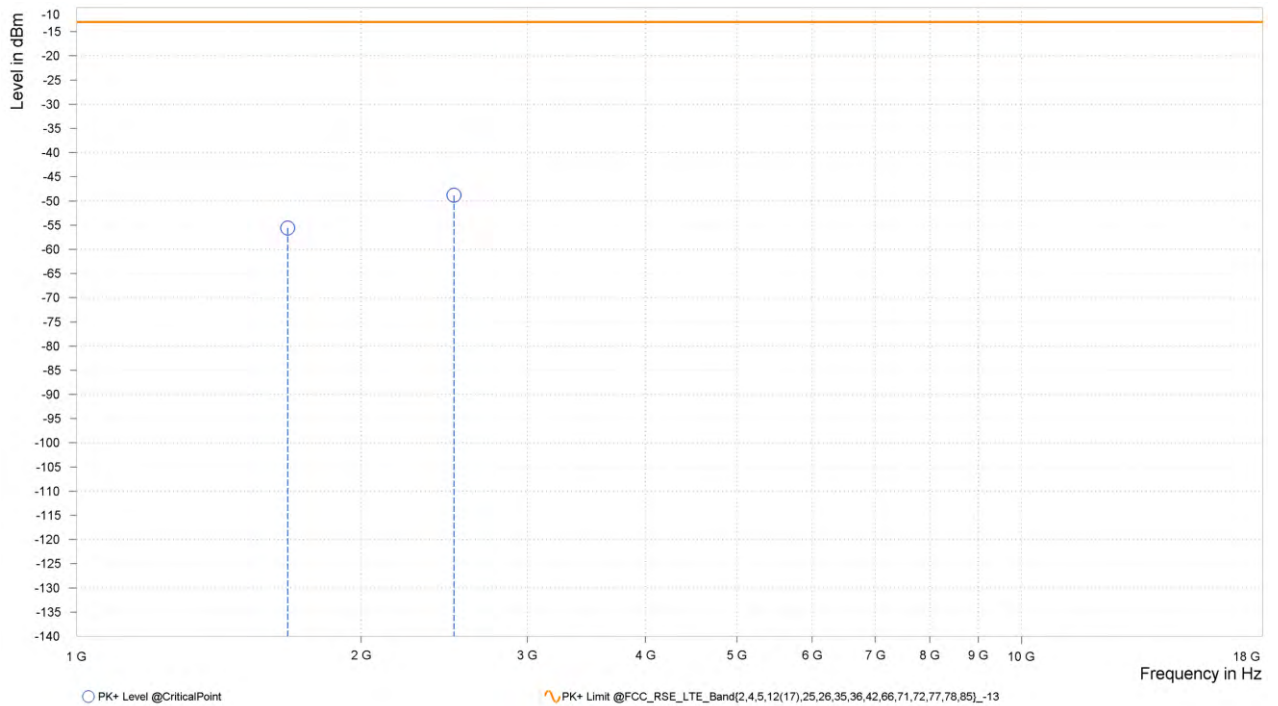



CHANNEL BANDWIDTH: 3MHz / QPSK

MODE	TX channel 26915	FREQUENCY RANGE	Above 1000MHz
ENVIRONMENTAL CONDITIONS	23deg. C, 70%RH	INPUT POWER	AC 120V/60HZ
TESTED BY	Jace Hu		
ANTENNA POLARITY & TEST DISTANCE: HORIZONTAL AT 3 M			

Rg	Frequency [MHz]	PK+ Level [dBm]	PK+ Limit [dBm]	PK+ Margin [dB]	Correction [dB]	Polarization	Azimuth [deg]	Antenna Height [m]
2	1,670.300	-54.94	-13.00	41.94	14.78	H	359	2.00
3	2,505.450	-49.77	-13.00	36.77	19.76	H	29.6	2.00

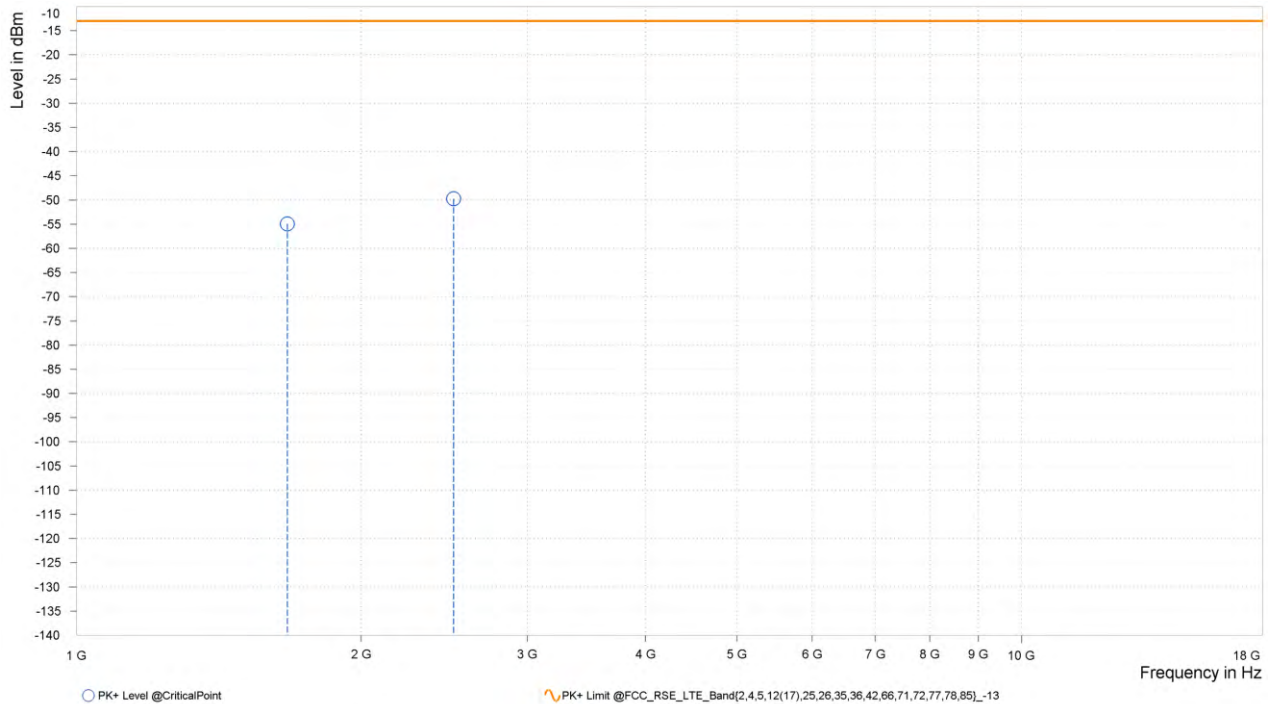



MODE	TX channel 26915	FREQUENCY RANGE	Above 1000MHz
ENVIRONMENTAL CONDITIONS	23deg. C, 70%RH	INPUT POWER	AC 120V/60HZ
TESTED BY	Jace Hu		
ANTENNA POLARITY & TEST DISTANCE: VERTICAL AT 3 M			

Rg	Frequency [MHz]	PK+ Level [dBm]	PK+ Limit [dBm]	PK+ Margin [dB]	Correction [dB]	Polarization	Azimuth [deg]	Antenna Height [m]
2	1,670.300	-56.29	-13.00	43.29	13.67	V	35.5	2.00
3	2,505.450	-48.68	-13.00	35.68	20.28	V	359	2.00

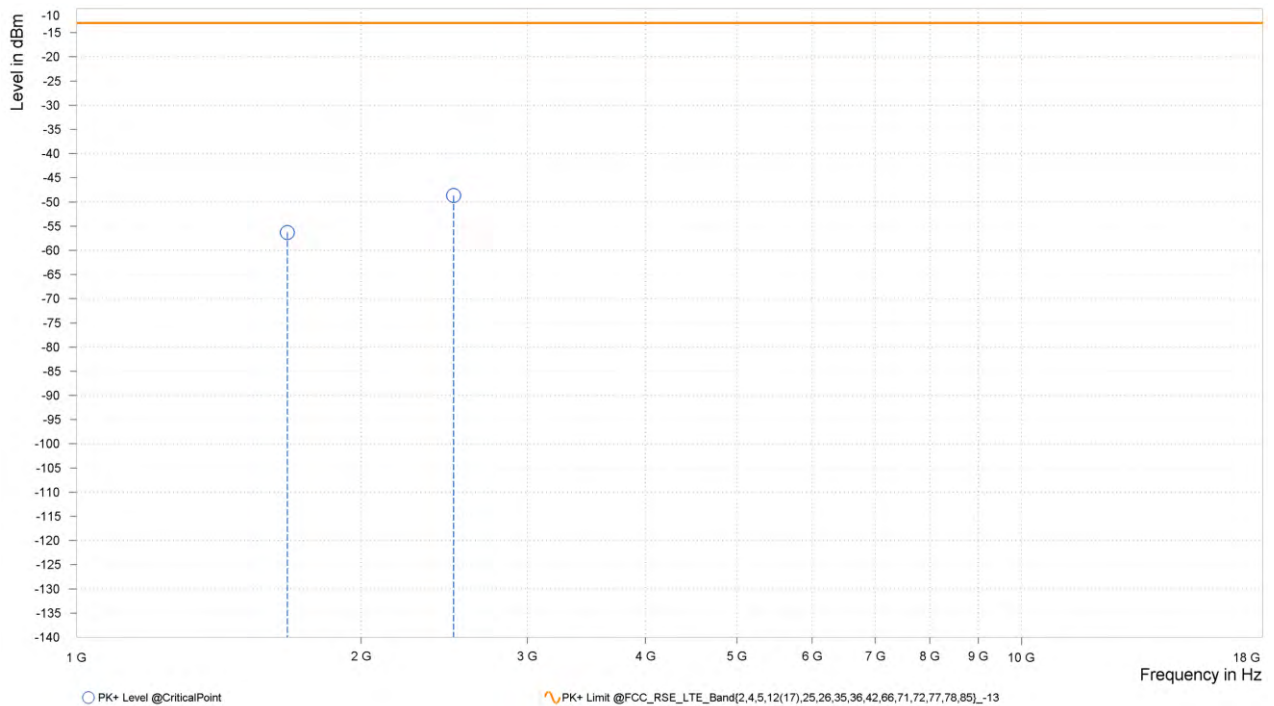



CHANNEL BANDWIDTH: 5MHz / QPSK
CH26815

MODE	TX channel 26815	FREQUENCY RANGE	Above 1000MHz
ENVIRONMENTAL CONDITIONS	23deg. C, 70%RH	INPUT POWER	AC 120V/60HZ
TESTED BY	Jace Hu		
ANTENNA POLARITY & TEST DISTANCE: HORIZONTAL AT 3 M			

Rg	Frequency [MHz]	PK+ Level [dBm]	PK+ Limit [dBm]	PK+ Margin [dB]	Correction [dB]	Polarization	Azimuth [deg]	Antenna Height [m]
2	1,648.500	-53.58	-13.00	40.58	14.07	H	305.7	2.00
3	2,472.750	-51.51	-13.00	38.51	19.28	H	166.6	1.00

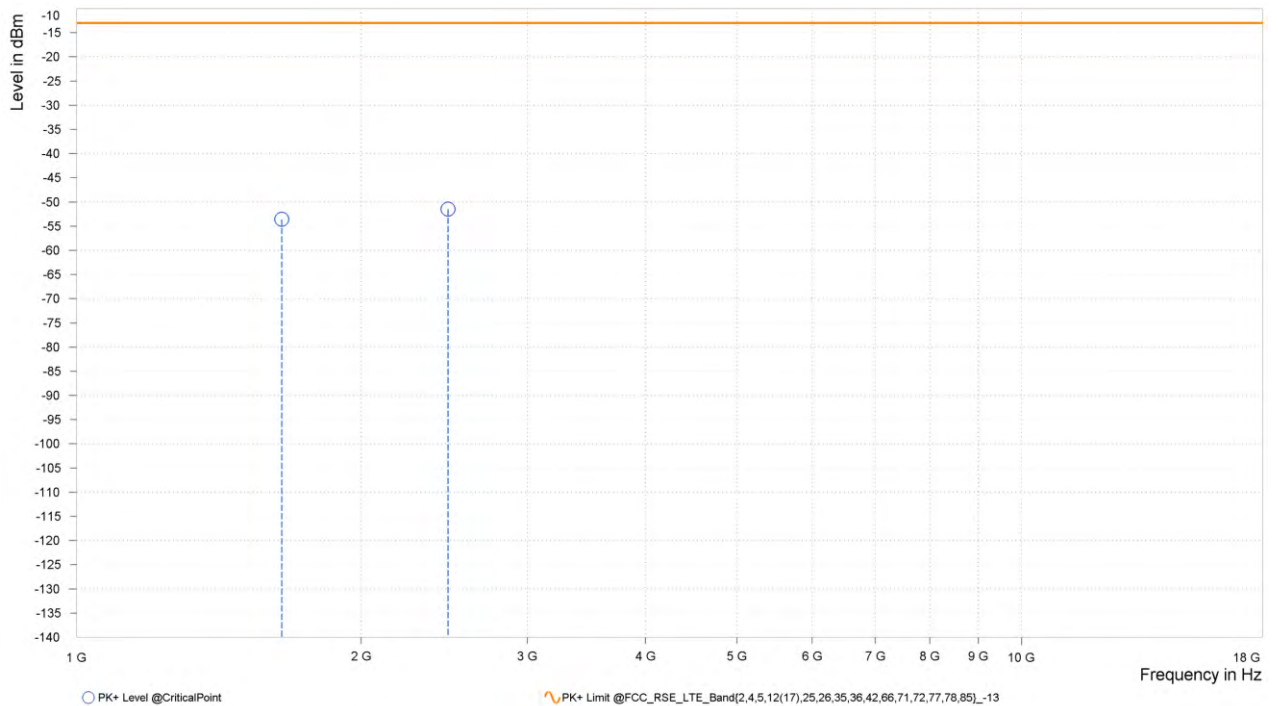



MODE	TX channel 26815	FREQUENCY RANGE	Above 1000MHz
ENVIRONMENTAL CONDITIONS	23deg. C, 70%RH	INPUT POWER	AC 120V/60HZ
TESTED BY	Jace Hu		
ANTENNA POLARITY & TEST DISTANCE: VERTICAL AT 3 M			

Rg	Frequency [MHz]	PK+ Level [dBm]	PK+ Limit [dBm]	PK+ Margin [dB]	Correction [dB]	Polarization	Azimuth [deg]	Antenna Height [m]
2	1,648.500	-54.99	-13.00	41.99	13.65	V	359	1.00
3	2,472.750	-50.09	-13.00	37.09	19.53	V	5.4	2.00

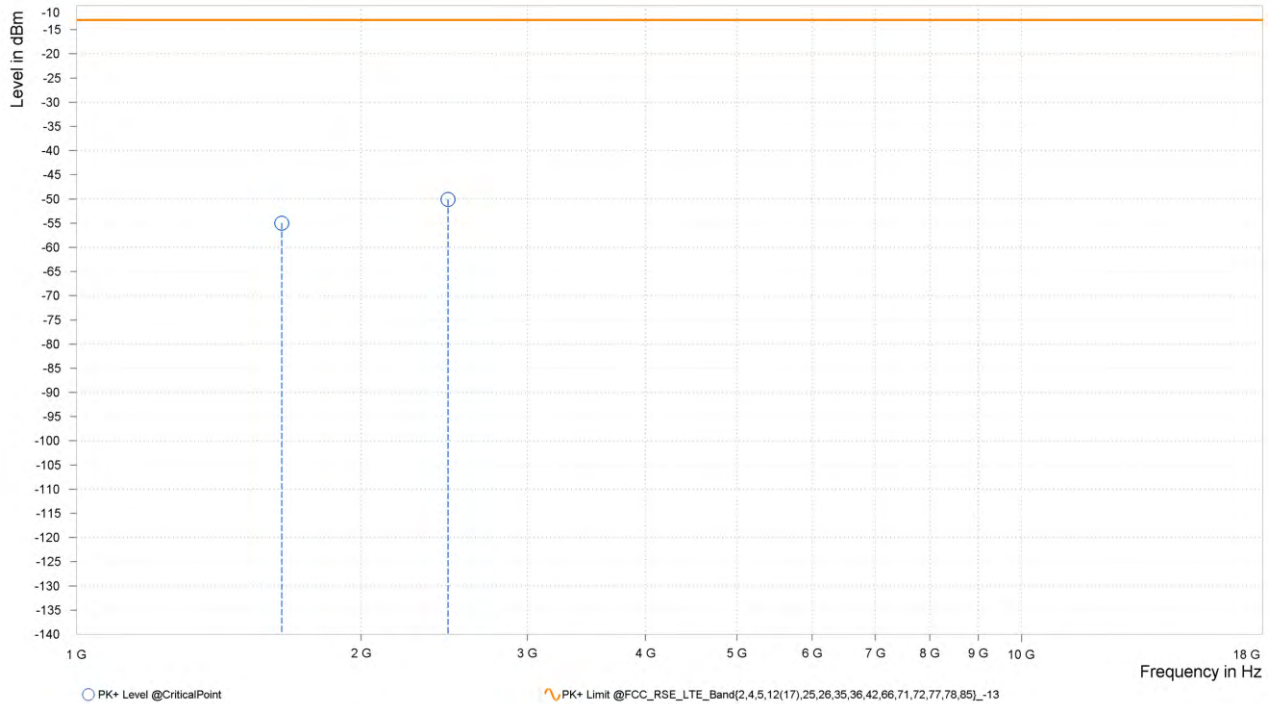



CH26915

MODE	TX channel 26915	FREQUENCY RANGE	Above 1000MHz
ENVIRONMENTAL CONDITIONS	23deg. C, 70%RH	INPUT POWER	AC 120V/60HZ
TESTED BY	Jace Hu		
ANTENNA POLARITY & TEST DISTANCE: HORIZONTAL AT 3 M			

Rg	Frequency [MHz]	PK+ Level [dBm]	PK+ Limit [dBm]	PK+ Margin [dB]	Correction [dB]	Polarization	Azimuth [deg]	Antenna Height [m]
2	1,668.500	-54.39	-13.00	41.39	14.75	H	358.6	1.00
3	2,502.750	-49.46	-13.00	36.46	19.80	H	359.1	1.00

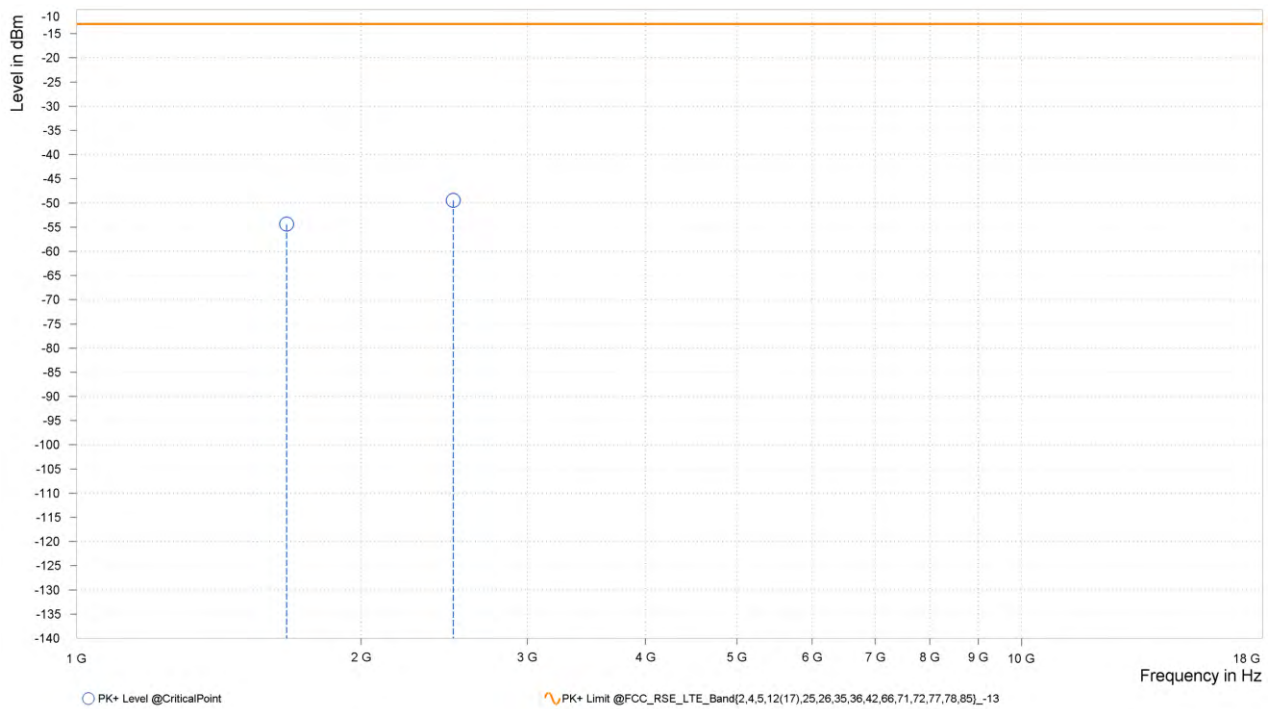



**BUREAU
VERITAS**

Test Report No.: PSU-NQN2403180115RF05

MODE	TX channel 26915	FREQUENCY RANGE	Above 1000MHz
ENVIRONMENTAL CONDITIONS	23deg. C, 70%RH	INPUT POWER	AC 120V/60HZ
TESTED BY	Jace Hu		
ANTENNA POLARITY & TEST DISTANCE: VERTICAL AT 3 M			

Rg	Frequency [MHz]	PK+ Level [dBm]	PK+ Limit [dBm]	PK+ Margin [dB]	Correction [dB]	Polarization	Azimuth [deg]	Antenna Height [m]
2	1,668.500	-56.17	-13.00	43.17	13.64	V	359	2.00
3	2,502.750	-48.32	-13.00	35.32	20.24	V	359.1	1.00

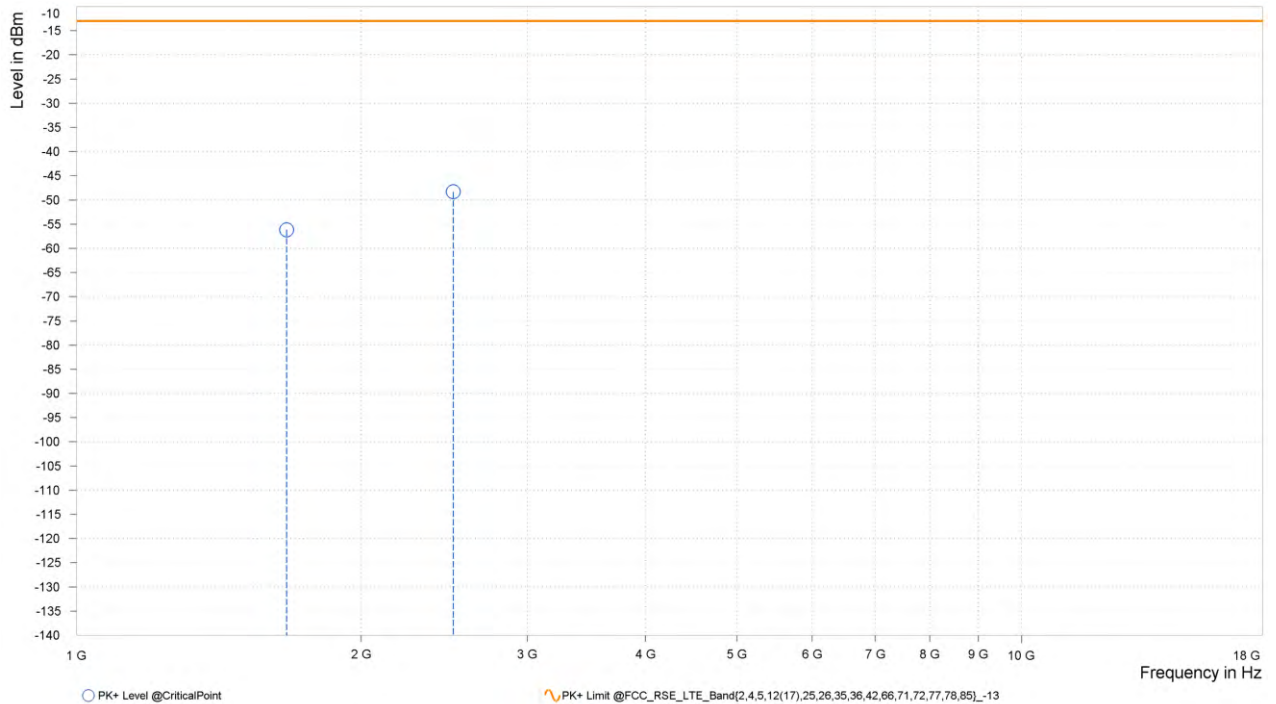



CH27015

MODE	TX channel 27015	FREQUENCY RANGE	Above 1000MHz
ENVIRONMENTAL CONDITIONS	23deg. C, 70%RH	INPUT POWER	AC 120V/60HZ
TESTED BY	Jace Hu		
ANTENNA POLARITY & TEST DISTANCE: HORIZONTAL AT 3 M			

Rg	Frequency [MHz]	PK+ Level [dBm]	PK+ Limit [dBm]	PK+ Margin [dB]	Correction [dB]	Polarization	Azimuth [deg]	Antenna Height [m]
2	1,688.500	-54.09	-13.00	41.09	15.05	H	316.2	1.00
3	2,532.750	-50.89	-13.00	37.89	19.40	H	359	1.00

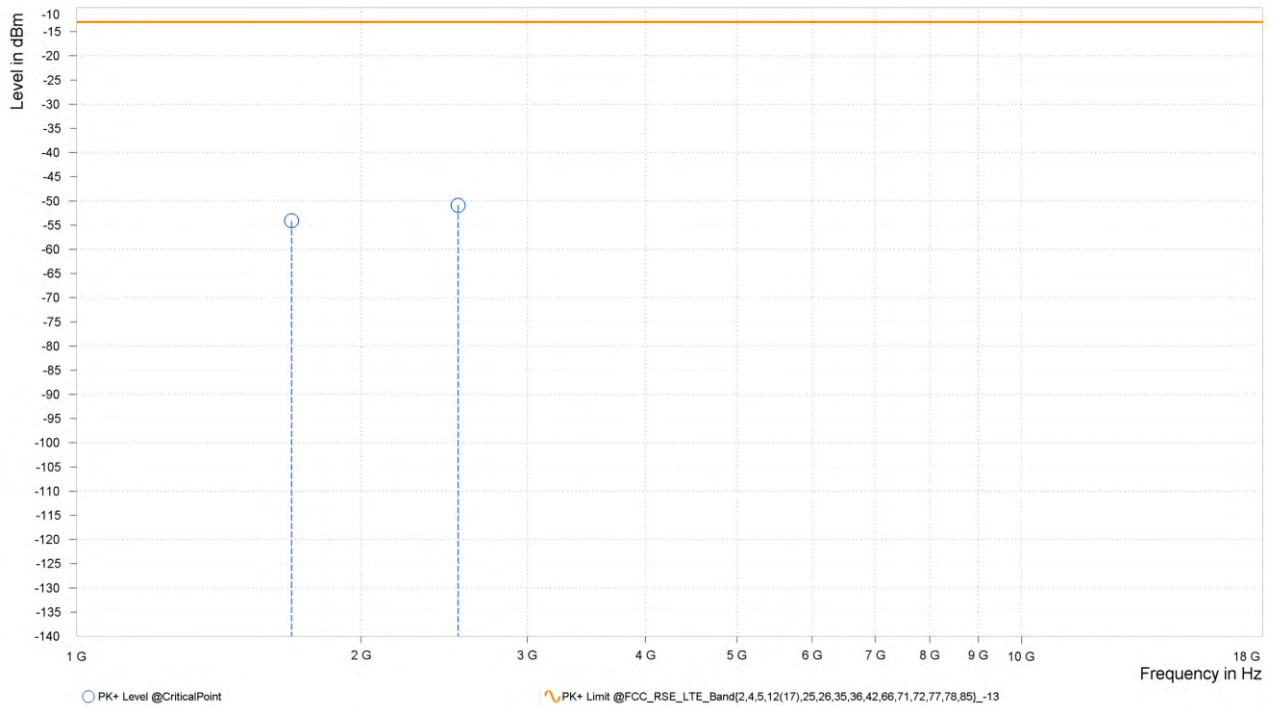



MODE	TX channel 27015	FREQUENCY RANGE	Above 1000MHz
ENVIRONMENTAL CONDITIONS	23deg. C, 70%RH	INPUT POWER	AC 120V/60HZ
TESTED BY	Jace Hu		
ANTENNA POLARITY & TEST DISTANCE: VERTICAL AT 3 M			

Rg	Frequency [MHz]	PK+ Level [dBm]	PK+ Limit [dBm]	PK+ Margin [dB]	Correction [dB]	Polarization	Azimuth [deg]	Antenna Height [m]
2	1,688.500	-55.50	-13.00	42.50	14.04	V	359.1	1.00
3	2,532.750	-50.93	-13.00	37.93	20.15	V	355	1.00

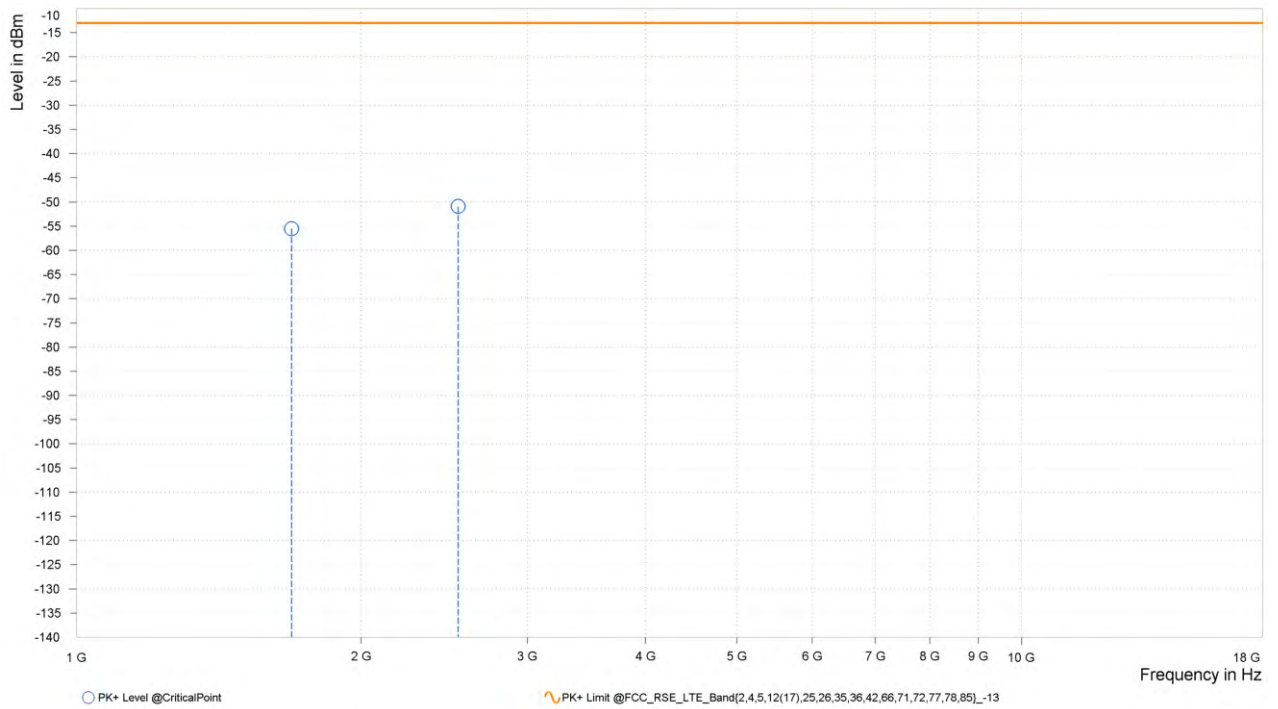



CHANNEL BANDWIDTH: 10MHz / QPSK

CH26915

MODE	TX channel 26915	FREQUENCY RANGE	Above 1000MHz
ENVIRONMENTAL CONDITIONS	23deg. C, 70%RH	INPUT POWER	AC 120V/60HZ
TESTED BY	Jace Hu		
ANTENNA POLARITY & TEST DISTANCE: HORIZONTAL AT 3 M			

Rg	Frequency [MHz]	PK+ Level [dBm]	PK+ Limit [dBm]	PK+ Margin [dB]	Correction [dB]	Polarization	Azimuth [deg]	Antenna Height [m]
2	1,664.000	-55.10	-13.00	42.10	14.67	H	54.3	1.00
3	2,496.000	-48.64	-13.00	35.64	19.88	H	108.1	1.00

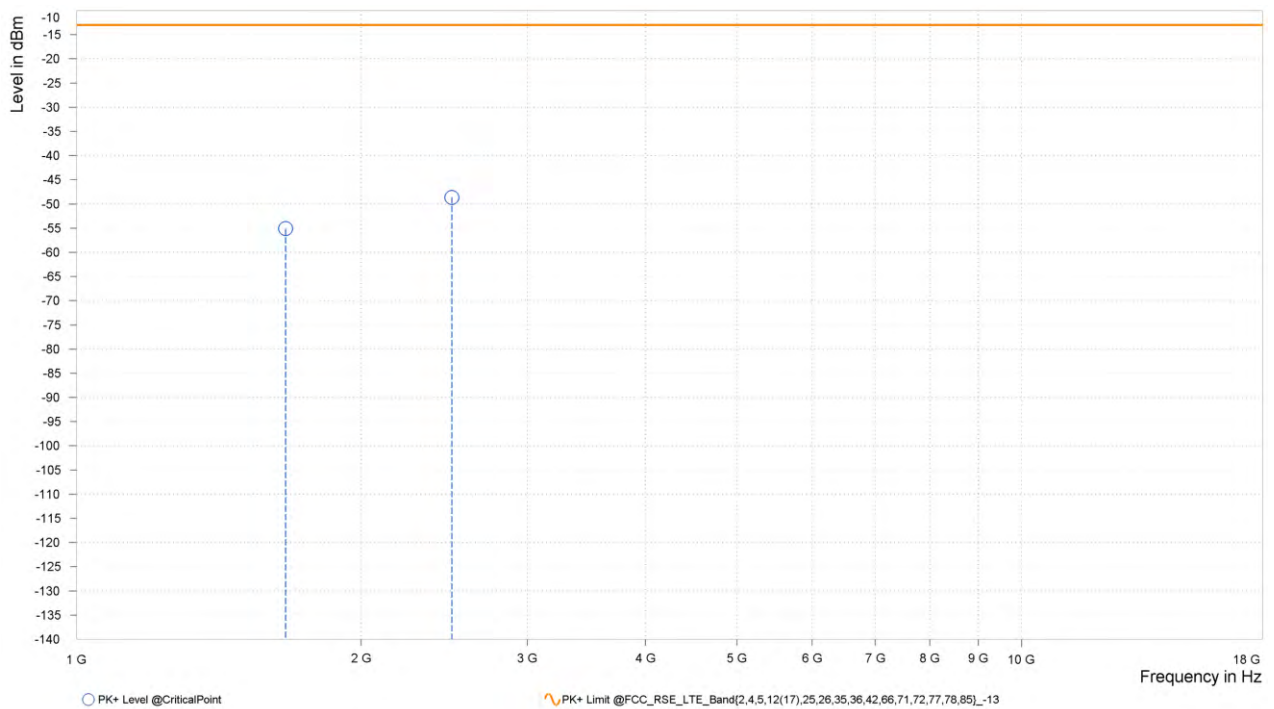



**BUREAU
VERITAS**

Test Report No.: PSU-NQN2403180115RF05

MODE	TX channel 26915	FREQUENCY RANGE	Above 1000MHz
ENVIRONMENTAL CONDITIONS	23deg. C, 70%RH	INPUT POWER	AC 120V/60HZ
TESTED BY	Jace Hu		
ANTENNA POLARITY & TEST DISTANCE: VERTICAL AT 3 M			

Rg	Frequency [MHz]	PK+ Level [dBm]	PK+ Limit [dBm]	PK+ Margin [dB]	Correction [dB]	Polarization	Azimuth [deg]	Antenna Height [m]
2	1,664.000	-55.35	-13.00	42.35	13.55	V	305.7	2.00
3	2,496.000	-49.21	-13.00	36.21	20.16	V	359	1.00

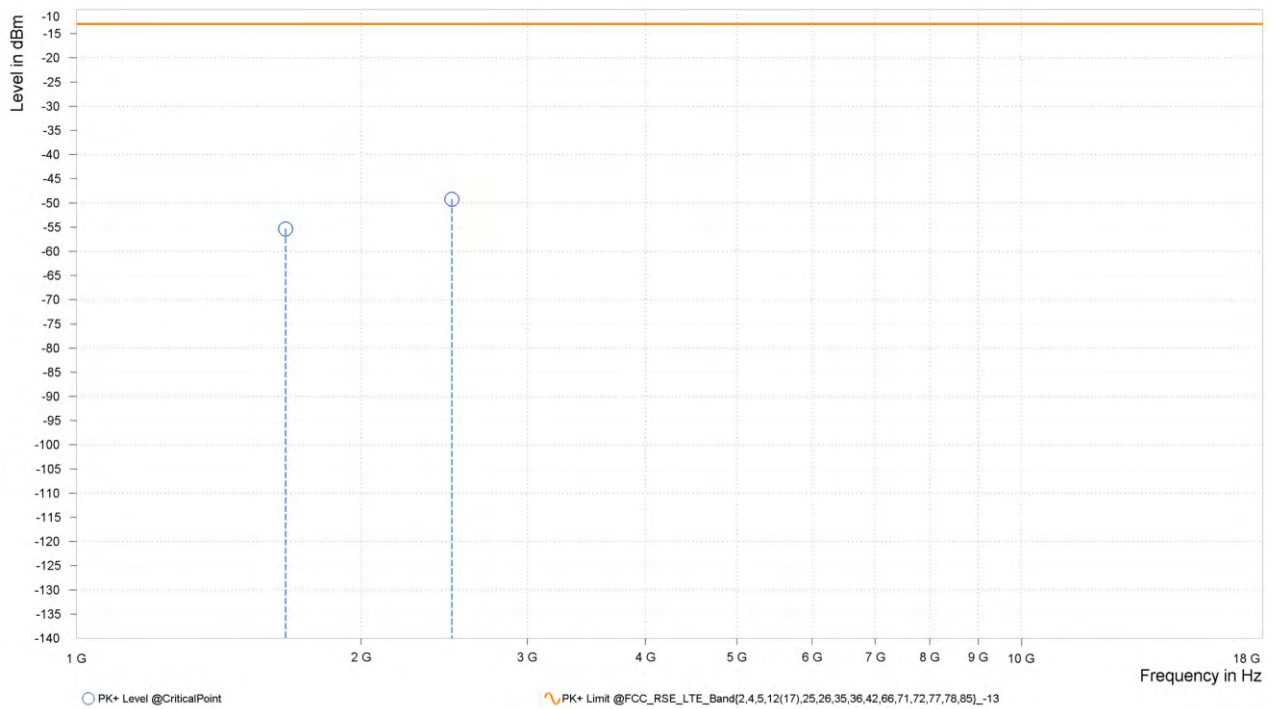



CHANNEL BANDWIDTH: 15MHz / QPSK

CH26915

MODE	TX channel 26915	FREQUENCY RANGE	Above 1000MHz
ENVIRONMENTAL CONDITIONS	23deg. C, 70%RH	INPUT POWER	AC 120V/60HZ
TESTED BY	Jace Hu		
ANTENNA POLARITY & TEST DISTANCE: HORIZONTAL AT 3 M			

Rg	Frequency [MHz]	PK+ Level [dBm]	PK+ Limit [dBm]	PK+ Margin [dB]	Correction [dB]	Polarization	Azimuth [deg]	Antenna Height [m]
2	1,659.500	-54.18	-13.00	41.18	14.60	H	1	1.00
3	2,489.250	-49.51	-13.00	36.51	19.77	H	1	1.00

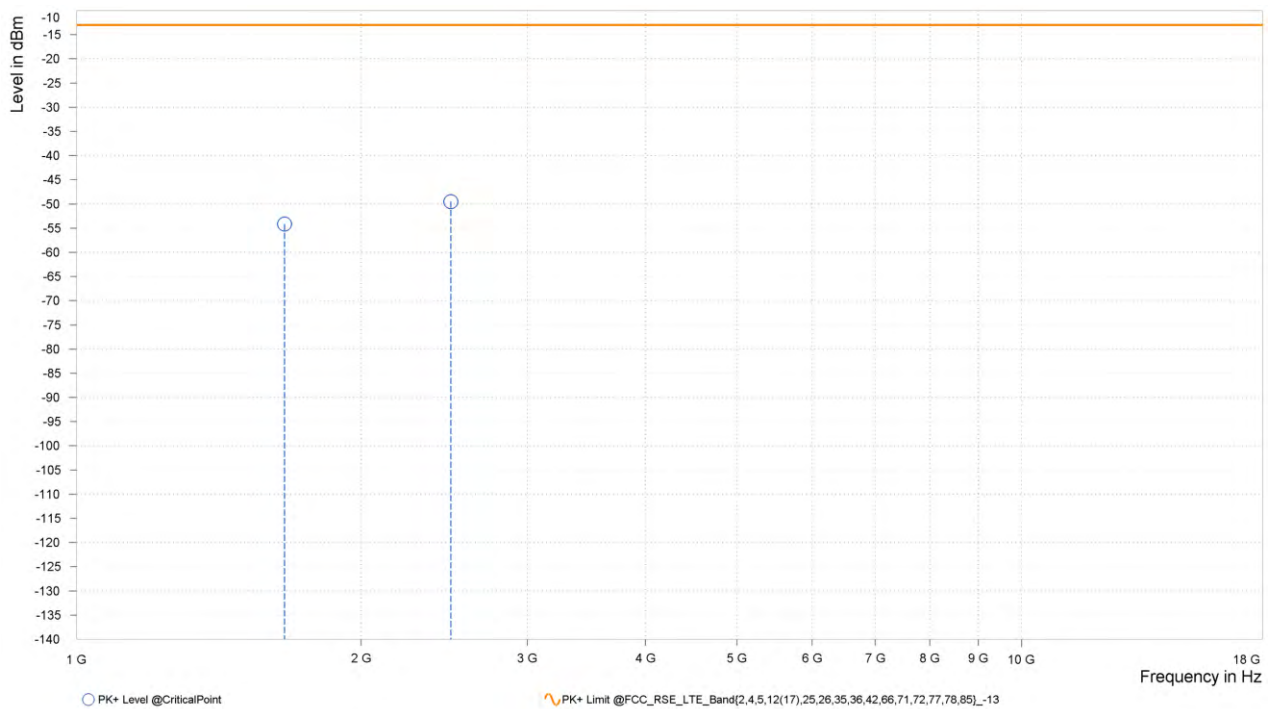



**BUREAU
VERITAS**

Test Report No.: PSU-NQN2403180115RF05

MODE	TX channel 26915	FREQUENCY RANGE	Above 1000MHz
ENVIRONMENTAL CONDITIONS	23deg. C, 70%RH	INPUT POWER	AC 120V/60HZ
TESTED BY	Jace Hu		
ANTENNA POLARITY & TEST DISTANCE: VERTICAL AT 3 M			

Rg	Frequency [MHz]	PK+ Level [dBm]	PK+ Limit [dBm]	PK+ Margin [dB]	Correction [dB]	Polarization	Azimuth [deg]	Antenna Height [m]
2	1,659.500	-56.11	-13.00	43.11	13.48	V	1	1.00
4	4,829.250	-50.81	-13.00	37.81	23.41	V	1	2.00

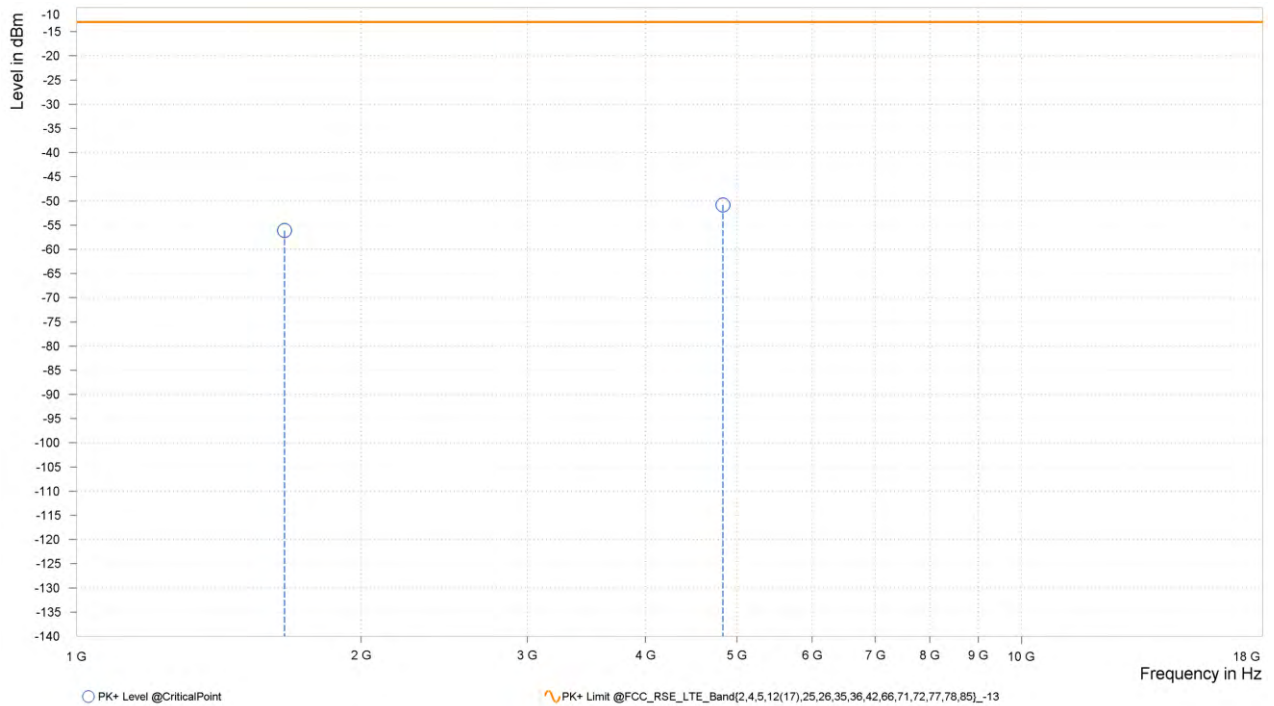



**BUREAU
VERITAS**

Test Report No.: PSU-NQN2403180115RF05

ENDC

CA_2A-5A

CHANNEL BANDWIDTH: 20MHz + 10MHz

MODE	TX channel 20525	FREQUENCY RANGE	Above 1000MHz
ENVIRONMENTAL CONDITIONS	23deg. C, 70%RH	INPUT POWER	AC 120V/60HZ
TESTED BY	Jace Hu		
ANTENNA POLARITY & TEST DISTANCE: HORIZONTAL AT 3 M			

Rg	Frequency [MHz]	PK+ Level [dBm]	PK+ Limit [dBm]	PK+ Margin [dB]	Correction [dB]	Polarization	Azimuth [deg]	Antenna Height [m]
2	1,649.000	-46.62	-13.00	33.62	23.75	H	1	2.00
3	2,473.500	-49.97	-13.00	36.97	19.31	H	256.7	2.00
4	3,702.000	-51.79	-13.00	38.79	20.97	H	1	1.00
4	5,553.500	-43.89	-13.00	30.89	23.75	H	1	1.00

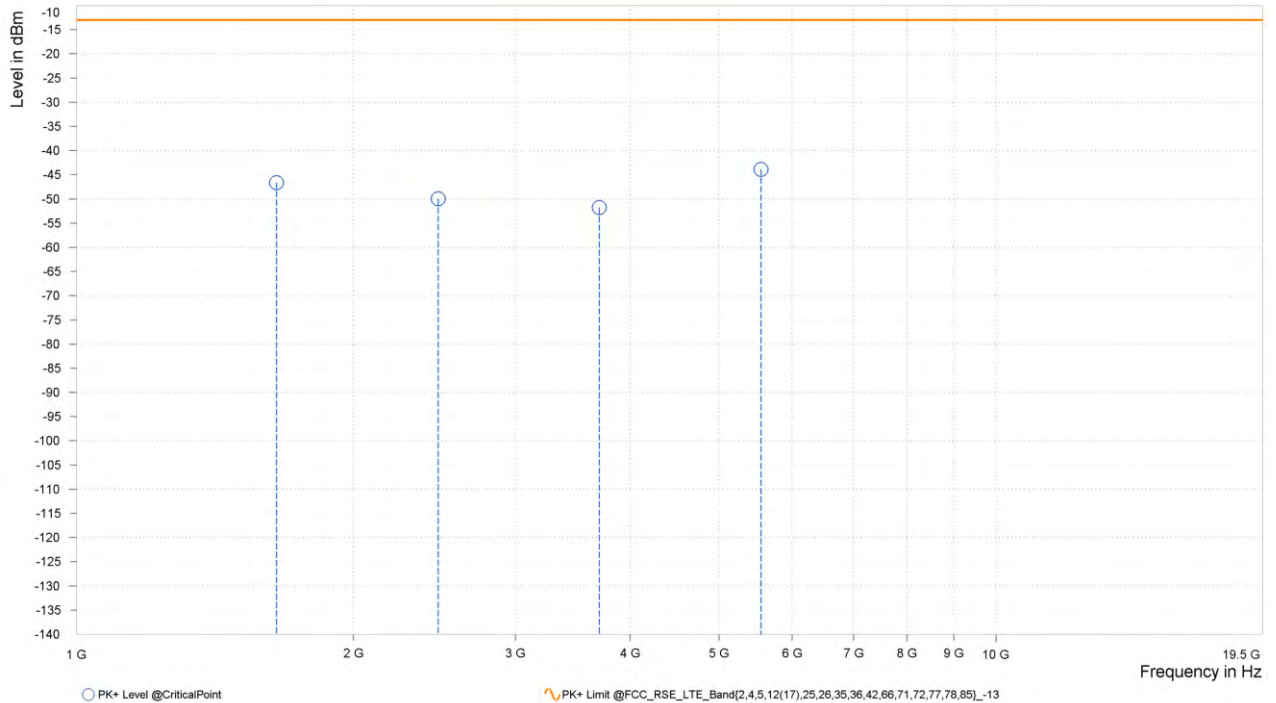



**BUREAU
VERITAS**

Test Report No.: PSU-NQN2403180115RF05

MODE	TX channel 20525	FREQUENCY RANGE	Above 1000MHz
ENVIRONMENTAL CONDITIONS	23deg. C, 70%RH	INPUT POWER	AC 120V/60HZ
TESTED BY	Jace Hu		
ANTENNA POLARITY & TEST DISTANCE: VERTICAL AT 3 M			

Rg	Frequency [MHz]	PK+ Level [dBm]	PK+ Limit [dBm]	PK+ Margin [dB]	Correction [dB]	Polarization	Azimuth [deg]	Antenna Height [m]
2	1,649.000	-46.16	-13.00	33.16	23.30	V	359	2.00
3	2,473.500	-50.85	-13.00	37.85	19.56	V	102.2	1.00
4	3,702.000	-50.31	-13.00	37.31	21.56	V	1	1.00
4	5,553.000	-34.39	-13.00	21.39	24.45	V	1	1.00

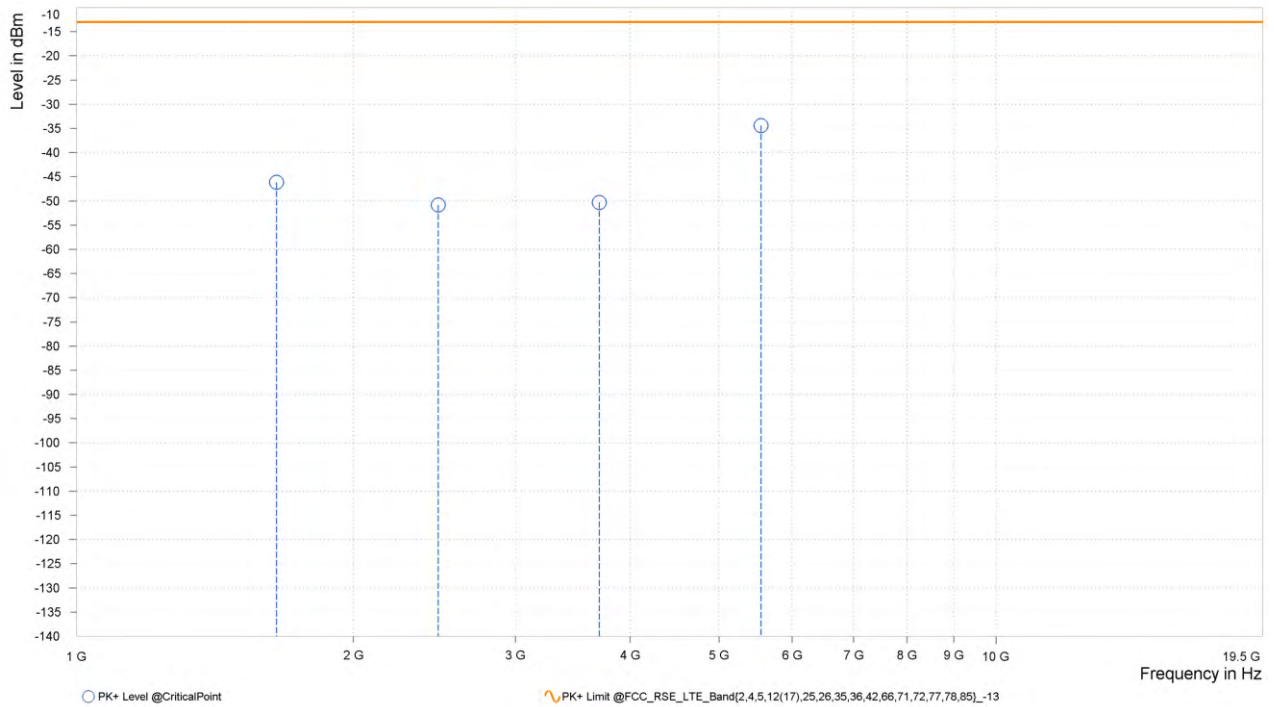



**BUREAU
VERITAS**

Test Report No.: PSU-NQN2403180115RF05

CHANNEL BANDWIDTH: 20MHz + 10MHz

MODE	TX channel 20525	FREQUENCY RANGE	Above 1000MHz
ENVIRONMENTAL CONDITIONS	23deg. C, 70%RH	INPUT POWER	AC 120V/60HZ
TESTED BY	Jace Hu		
ANTENNA POLARITY & TEST DISTANCE: HORIZONTAL AT 3 M			

Rg	Frequency [MHz]	PK+ Level [dBm]	PK+ Limit [dBm]	PK+ Margin [dB]	Correction [dB]	Polarization	Azimuth [deg]	Antenna Height [m]
2	1,664.000	-45.09	-13.00	32.09	24.37	H	0.9	2.00
3	2,496.000	-51.14	-13.00	38.14	19.88	H	359	2.00
4	3,742.000	-52.71	-13.00	39.71	20.95	H	359	2.00
4	5,614.000	-40.27	-13.00	27.27	23.99	H	0.9	2.00

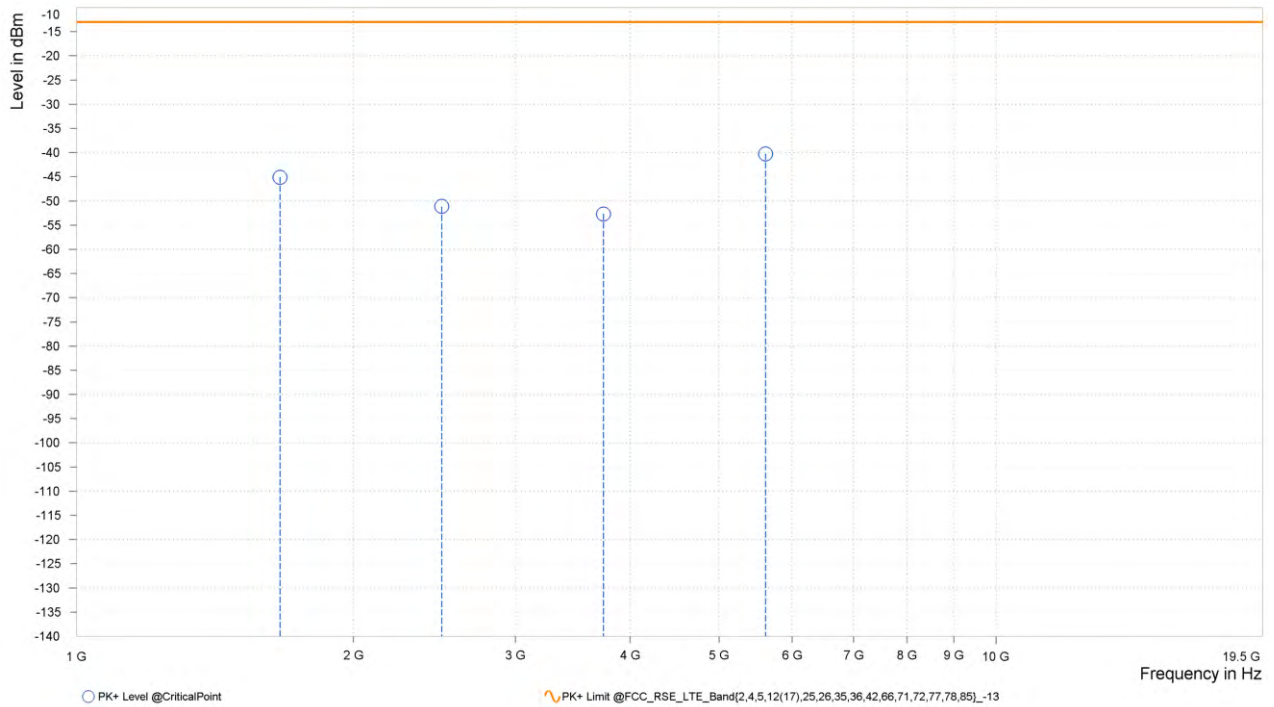



**BUREAU
VERITAS**

Test Report No.: PSU-NQN2403180115RF05

MODE	TX channel 20525	FREQUENCY RANGE	Above 1000MHz
ENVIRONMENTAL CONDITIONS	23deg. C, 70%RH	INPUT POWER	AC 120V/60HZ
TESTED BY	Jace Hu		
ANTENNA POLARITY & TEST DISTANCE: VERTICAL AT 3 M			

Rg	Frequency [MHz]	PK+ Level [dBm]	PK+ Limit [dBm]	PK+ Margin [dB]	Correction [dB]	Polarization	Azimuth [deg]	Antenna Height [m]
2	1,664.000	-46.19	-13.00	33.19	23.25	V	359	1.00
3	2,496.000	-49.10	-13.00	36.10	20.16	V	359	2.00
4	3,742.000	-49.92	-13.00	36.92	21.60	V	2.2	2.00
4	5,613.000	-33.27	-13.00	20.27	24.43	V	1	1.00

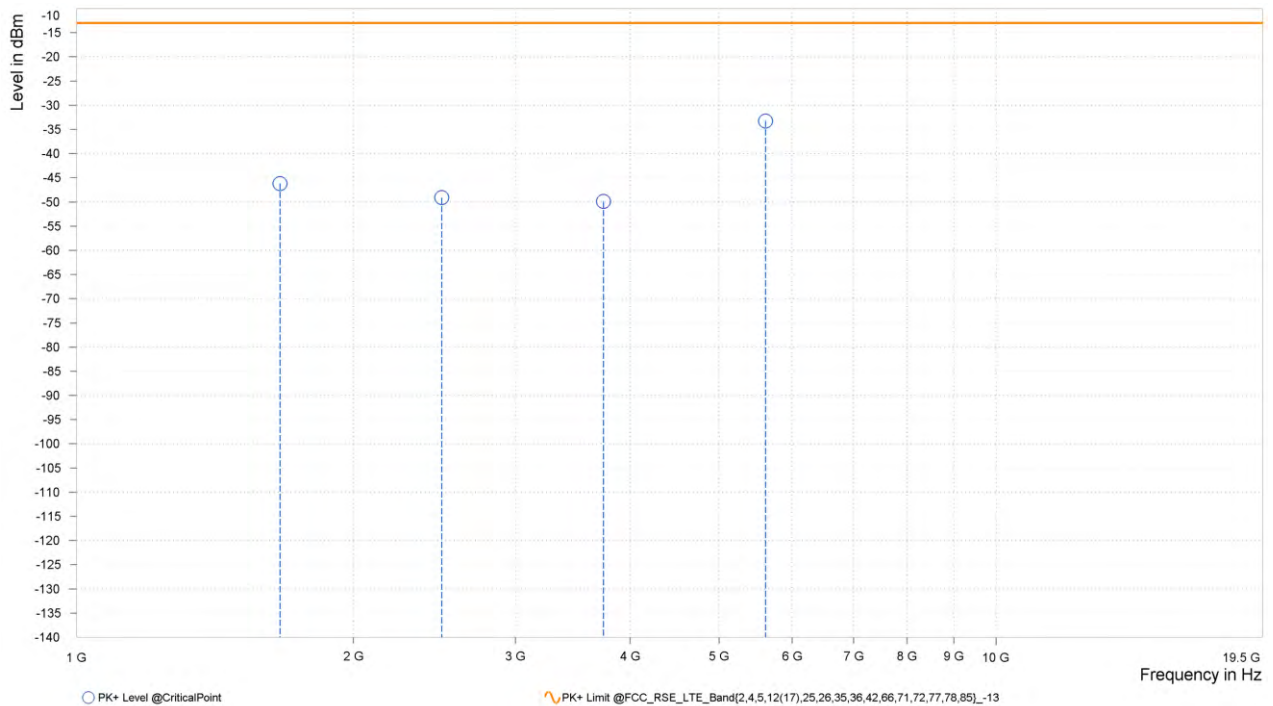



CHANNEL BANDWIDTH: 20MHz + 10MHz

MODE	TX channel 20525	FREQUENCY RANGE	Above 1000MHz
ENVIRONMENTAL CONDITIONS	23deg. C, 70%RH	INPUT POWER	AC 120V/60HZ
TESTED BY	Jace Hu		
ANTENNA POLARITY & TEST DISTANCE: HORIZONTAL AT 3 M			

Rg	Frequency [MHz]	PK+ Level [dBm]	PK+ Limit [dBm]	PK+ Margin [dB]	Correction [dB]	Polarization	Azimuth [deg]	Antenna Height [m]
2	1,679.000	-44.76	-13.00	31.76	24.60	H	55.8	2.00
3	2,518.500	-50.76	-13.00	37.76	19.48	H	359	1.00
4	3,782.000	-50.45	-13.00	37.45	21.58	H	359	1.00
4	5,674.000	-38.37	-13.00	25.37	24.20	H	1	1.00

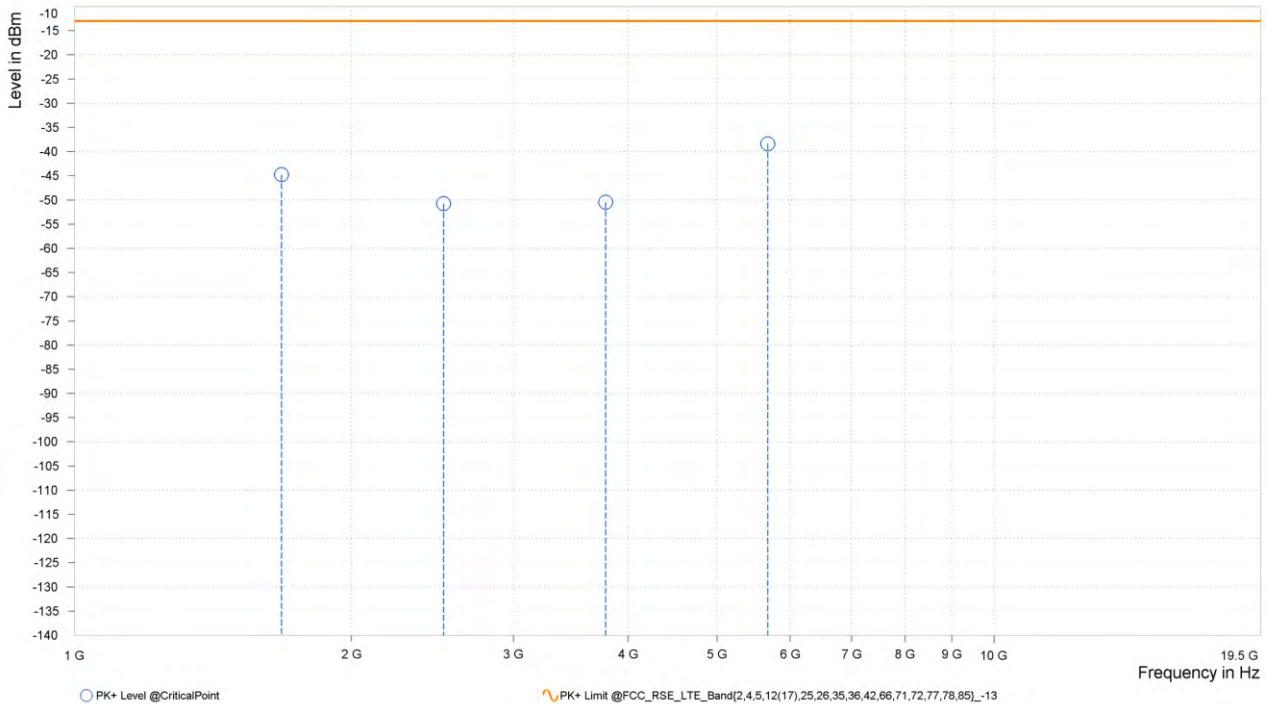



**BUREAU
VERITAS**

Test Report No.: PSU-NQN2403180115RF05

MODE	TX channel 20525	FREQUENCY RANGE	Above 1000MHz
ENVIRONMENTAL CONDITIONS	23deg. C, 70%RH	INPUT POWER	AC 120V/60HZ
TESTED BY	Jace Hu		
ANTENNA POLARITY & TEST DISTANCE: VERTICAL AT 3 M			

Rg	Frequency [MHz]	PK+ Level [dBm]	PK+ Limit [dBm]	PK+ Margin [dB]	Correction [dB]	Polarization	Azimuth [deg]	Antenna Height [m]
2	1,679.000	-45.54	-13.00	32.54	23.51	V	305.4	1.00
3	2,518.500	-50.67	-13.00	37.67	20.32	V	359	2.00
4	3,782.000	-49.29	-13.00	36.29	21.78	V	30.8	2.00
4	5,673.500	-33.79	-13.00	20.79	24.60	V	30.8	2.00

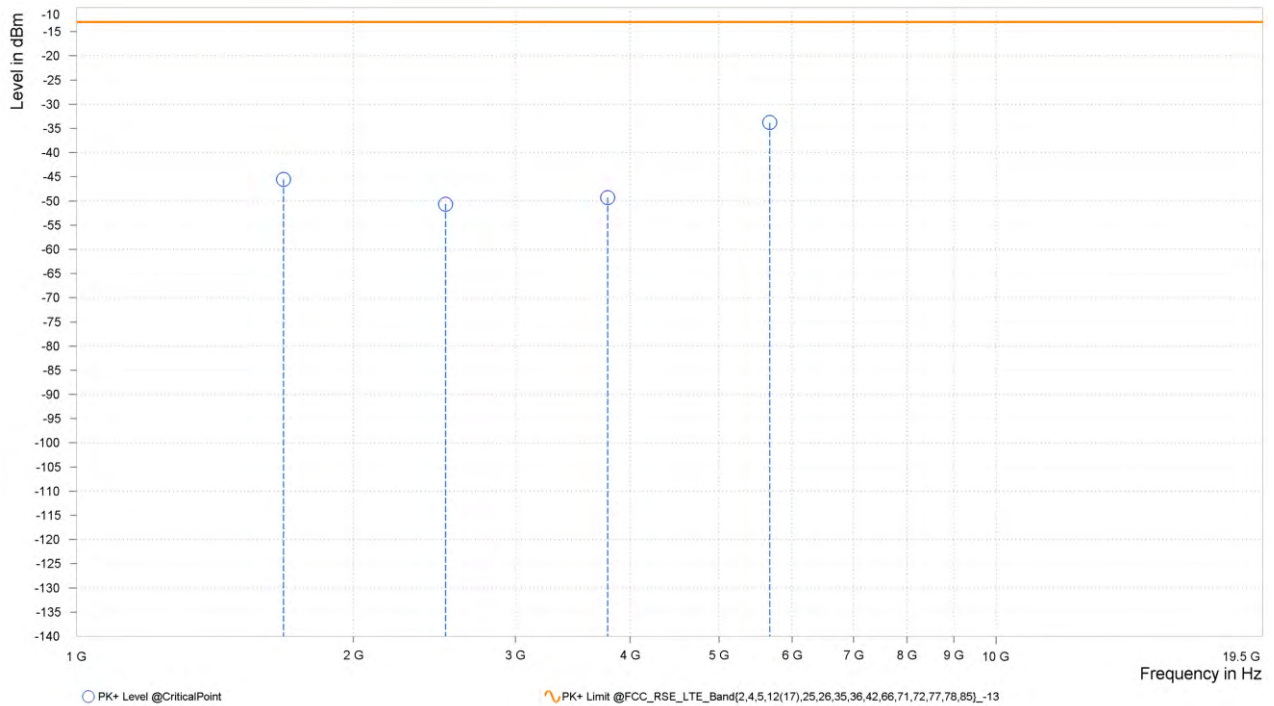



**BUREAU
VERITAS**

Test Report No.: PSU-NQN2403180115RF05

CA_4A-5A

CHANNEL BANDWIDTH: 20MHz + 10MHz

MODE	TX channel 20525	FREQUENCY RANGE	Above 1000MHz
ENVIRONMENTAL CONDITIONS	23deg. C, 70%RH	INPUT POWER	AC 120V/60HZ
TESTED BY	Jace Hu		
ANTENNA POLARITY & TEST DISTANCE: HORIZONTAL AT 3 M			

Rg	Frequency [MHz]	PK+ Level [dBm]	PK+ Limit [dBm]	PK+ Margin [dB]	Correction [dB]	Polarization	Azimuth [deg]	Antenna Height [m]
2	1,649.000	-46.29	-13.00	33.29	23.75	H	359	2.00
3	2,473.500	-50.03	-13.00	37.03	19.31	H	48.6	2.00
4	3,422.000	-52.04	-13.00	39.04	20.65	H	324.5	1.00
4	5,133.500	-43.71	-13.00	30.71	23.09	H	153.5	1.00

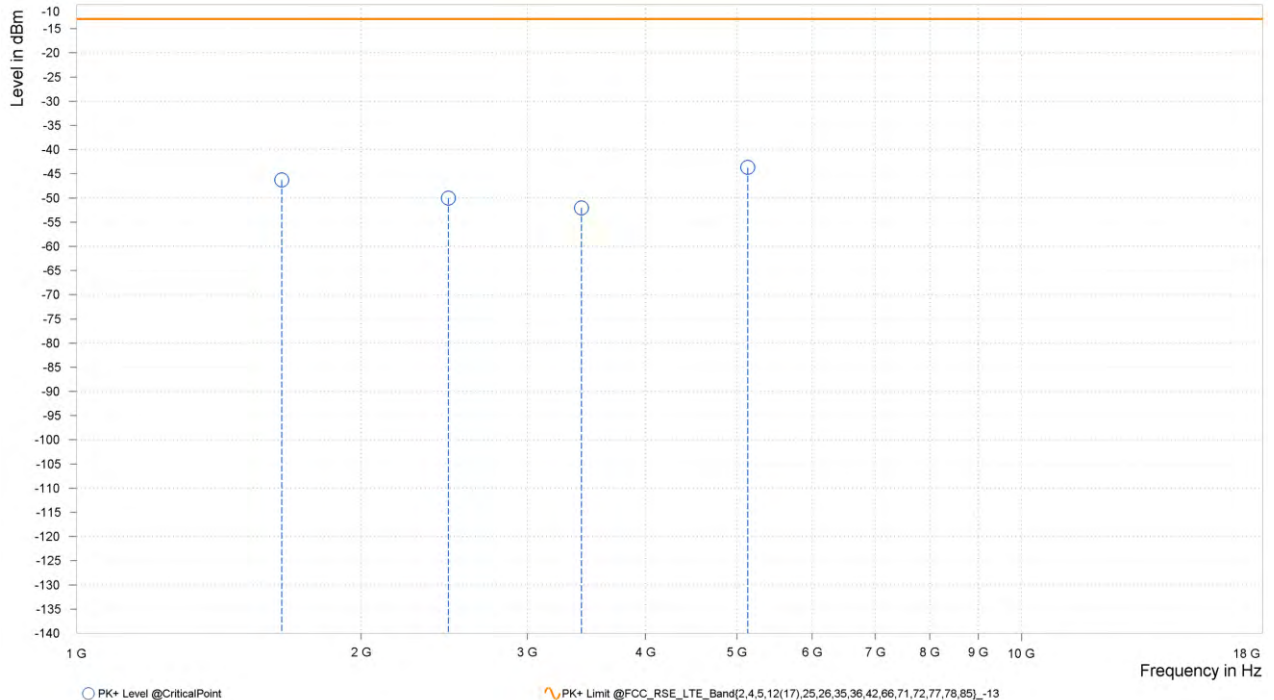



**BUREAU
VERITAS**

Test Report No.: PSU-NQN2403180115RF05

MODE	TX channel 20525	FREQUENCY RANGE	Above 1000MHz
ENVIRONMENTAL CONDITIONS	23deg. C, 70%RH	INPUT POWER	AC 120V/60HZ
TESTED BY	Jace Hu		
ANTENNA POLARITY & TEST DISTANCE: VERTICAL AT 3 M			

Rg	Frequency [MHz]	PK+ Level [dBm]	PK+ Limit [dBm]	PK+ Margin [dB]	Correction [dB]	Polarization	Azimuth [deg]	Antenna Height [m]
2	1,649.000	-47.03	-13.00	34.03	23.30	V	54.2	1.00
3	2,473.500	-48.43	-13.00	35.43	19.56	V	351.2	1.00
4	3,422.000	-50.51	-13.00	37.51	21.01	V	150.3	2.00
4	5,133.000	-47.83	-13.00	34.83	23.40	V	173.8	1.00

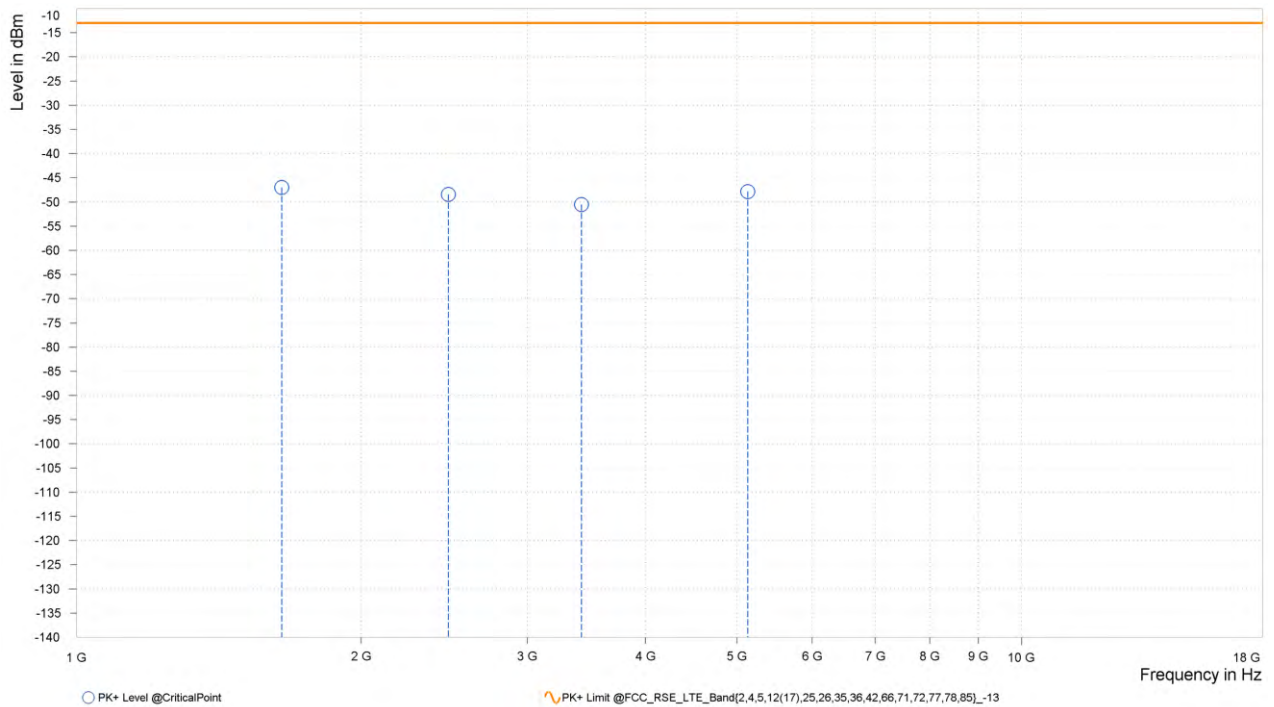



**BUREAU
VERITAS**

Test Report No.: PSU-NQN2403180115RF05

CHANNEL BANDWIDTH: 20MHz + 10MHz

MODE	TX channel 20525	FREQUENCY RANGE	Above 1000MHz
ENVIRONMENTAL CONDITIONS	23deg. C, 70%RH	INPUT POWER	AC 120V/60HZ
TESTED BY	Jace Hu		
ANTENNA POLARITY & TEST DISTANCE: HORIZONTAL AT 3 M			

Rg	Frequency [MHz]	PK+ Level [dBm]	PK+ Limit [dBm]	PK+ Margin [dB]	Correction [dB]	Polarization	Azimuth [deg]	Antenna Height [m]
2	1,664.000	-45.71	-13.00	32.71	24.37	H	295.8	1.00
3	2,496.000	-50.35	-13.00	37.35	19.88	H	102.2	1.00
4	3,447.000	-49.61	-13.00	36.61	20.50	H	359	2.00
4	5,171.000	-37.45	-13.00	24.45	23.29	H	1	1.00

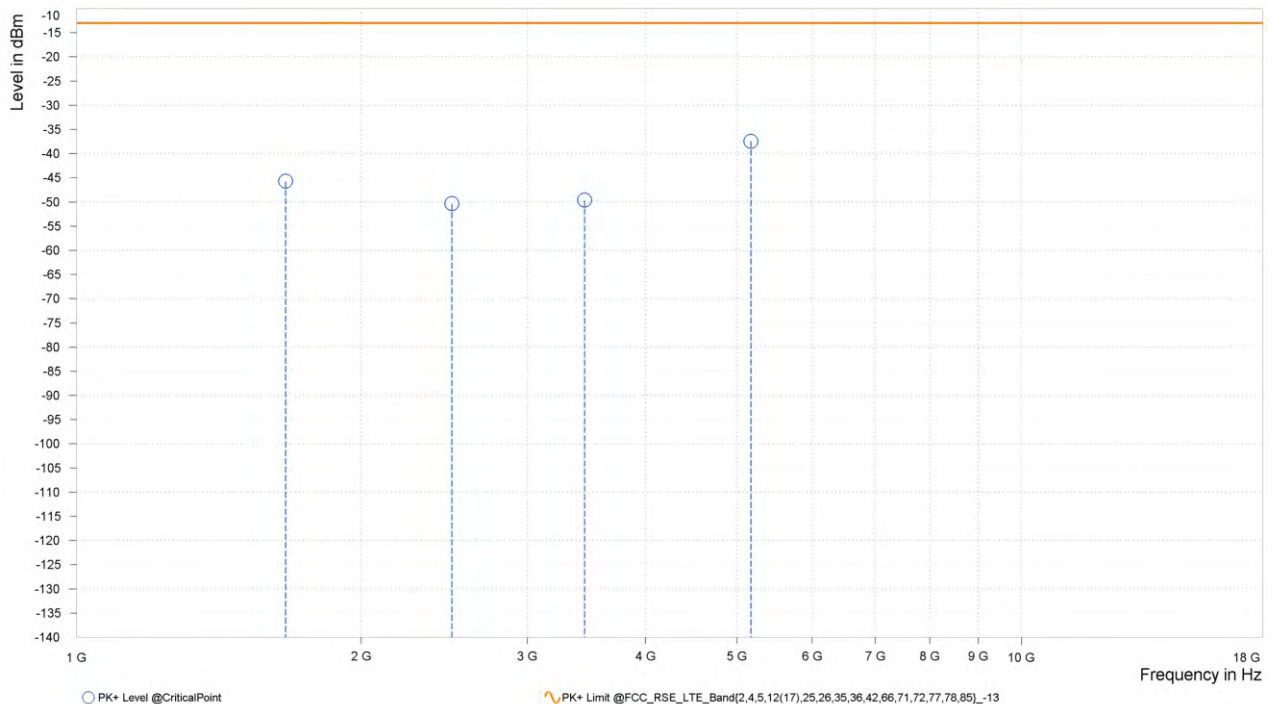



**BUREAU
VERITAS**

Test Report No.: PSU-NQN2403180115RF05

MODE	TX channel 20525	FREQUENCY RANGE	Above 1000MHz
ENVIRONMENTAL CONDITIONS	23deg. C, 70%RH	INPUT POWER	AC 120V/60HZ
TESTED BY	Jace Hu		
ANTENNA POLARITY & TEST DISTANCE: VERTICAL AT 3 M			

Rg	Frequency [MHz]	PK+ Level [dBm]	PK+ Limit [dBm]	PK+ Margin [dB]	Correction [dB]	Polarization	Azimuth [deg]	Antenna Height [m]
2	1,664.000	-46.49	-13.00	33.49	23.25	V	358.6	1.00
3	2,496.000	-49.75	-13.00	36.75	20.16	V	0.9	2.00
4	3,447.000	-50.37	-13.00	37.37	21.07	V	325.6	1.00
4	5,170.500	-47.48	-13.00	34.48	23.66	V	36.6	2.00

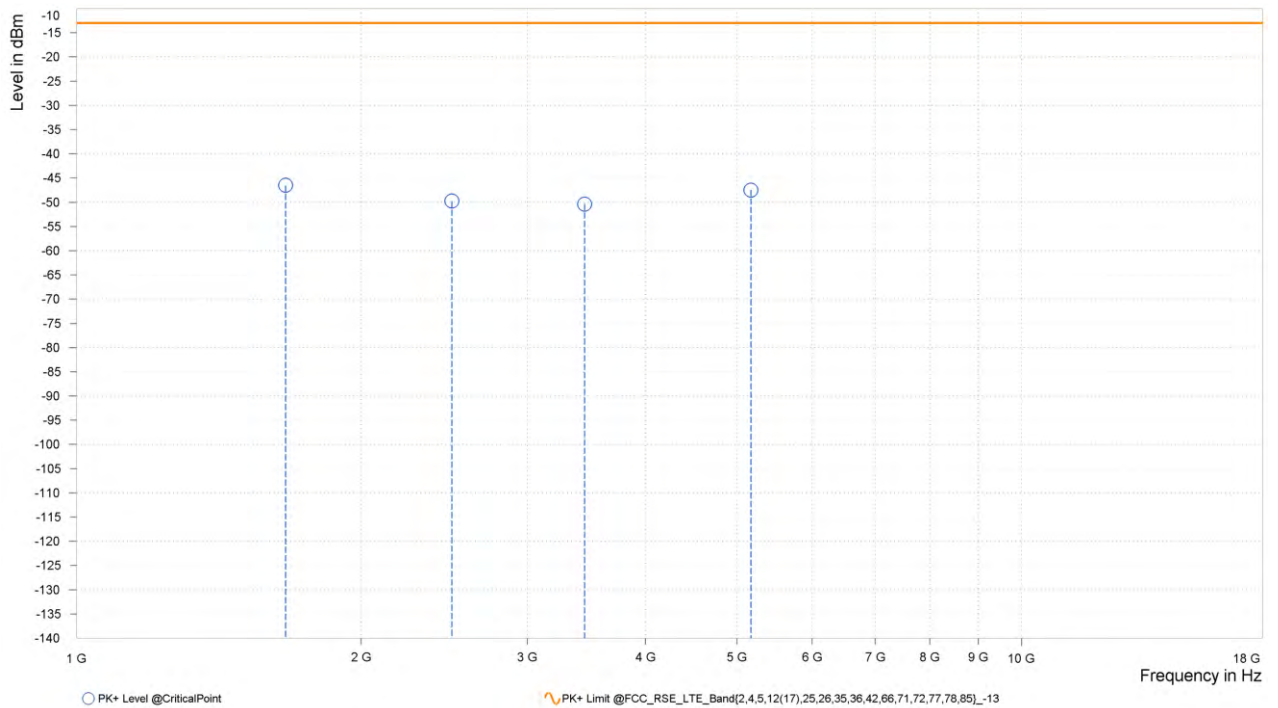



CHANNEL BANDWIDTH: 20MHz + 10MHz

MODE	TX channel 20525	FREQUENCY RANGE	Above 1000MHz
ENVIRONMENTAL CONDITIONS	23deg. C, 70%RH	INPUT POWER	AC 120V/60HZ
TESTED BY	Jace Hu		
ANTENNA POLARITY & TEST DISTANCE: HORIZONTAL AT 3 M			

Rg	Frequency [MHz]	PK+ Level [dBm]	PK+ Limit [dBm]	PK+ Margin [dB]	Correction [dB]	Polarization	Azimuth [deg]	Antenna Height [m]
2	1,679.000	-44.71	-13.00	31.71	24.60	H	61.4	1.00
3	2,518.500	-50.80	-13.00	37.80	19.48	H	323.2	1.00
4	3,472.000	-52.69	-13.00	39.69	20.43	H	359	2.00
4	5,208.500	-40.88	-13.00	27.88	23.47	H	206.5	2.00

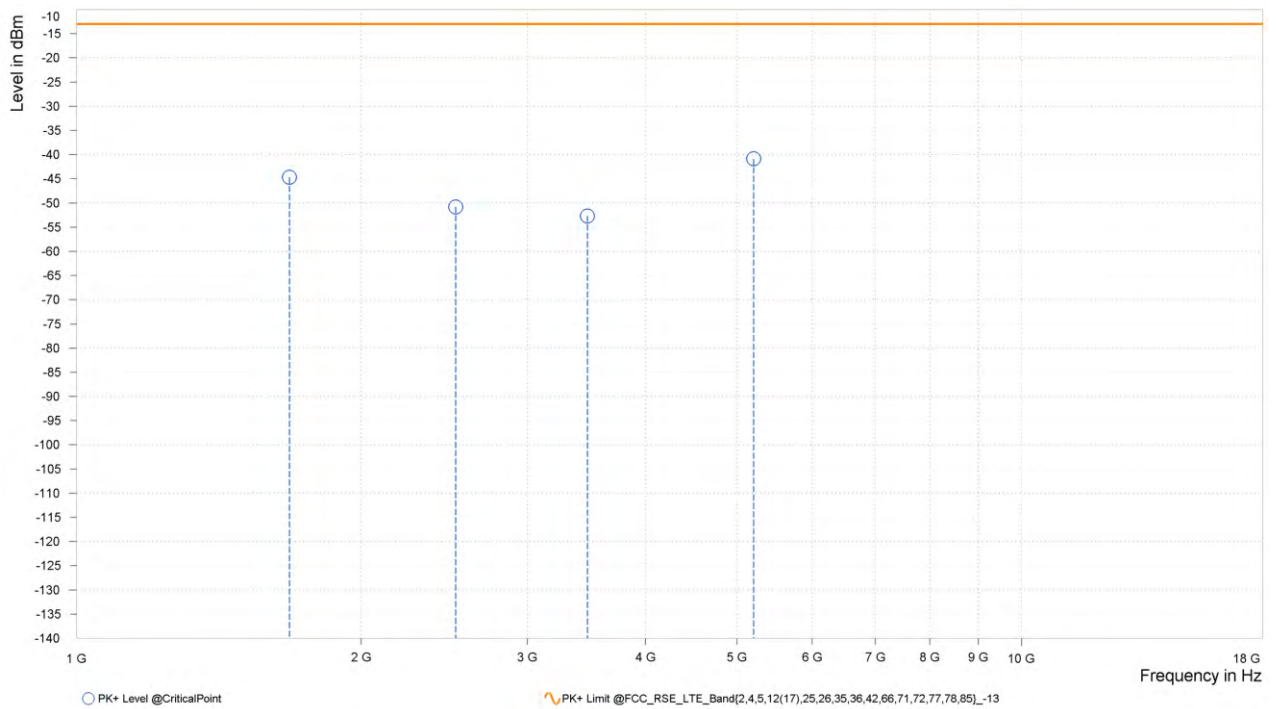



**BUREAU
VERITAS**

Test Report No.: PSU-NQN2403180115RF05

MODE	TX channel 20525	FREQUENCY RANGE	Above 1000MHz
ENVIRONMENTAL CONDITIONS	23deg. C, 70%RH	INPUT POWER	AC 120V/60HZ
TESTED BY	Jace Hu		
ANTENNA POLARITY & TEST DISTANCE: VERTICAL AT 3 M			

Rg	Frequency [MHz]	PK+ Level [dBm]	PK+ Limit [dBm]	PK+ Margin [dB]	Correction [dB]	Polarization	Azimuth [deg]	Antenna Height [m]
2	1,679.000	-45.85	-13.00	32.85	23.51	V	357.9	1.00
3	2,518.500	-49.87	-13.00	36.87	20.32	V	1	2.00
4	3,472.000	-51.35	-13.00	38.35	21.15	V	208.9	2.00
4	5,208.000	-47.15	-13.00	34.15	24.07	V	153.5	1.00

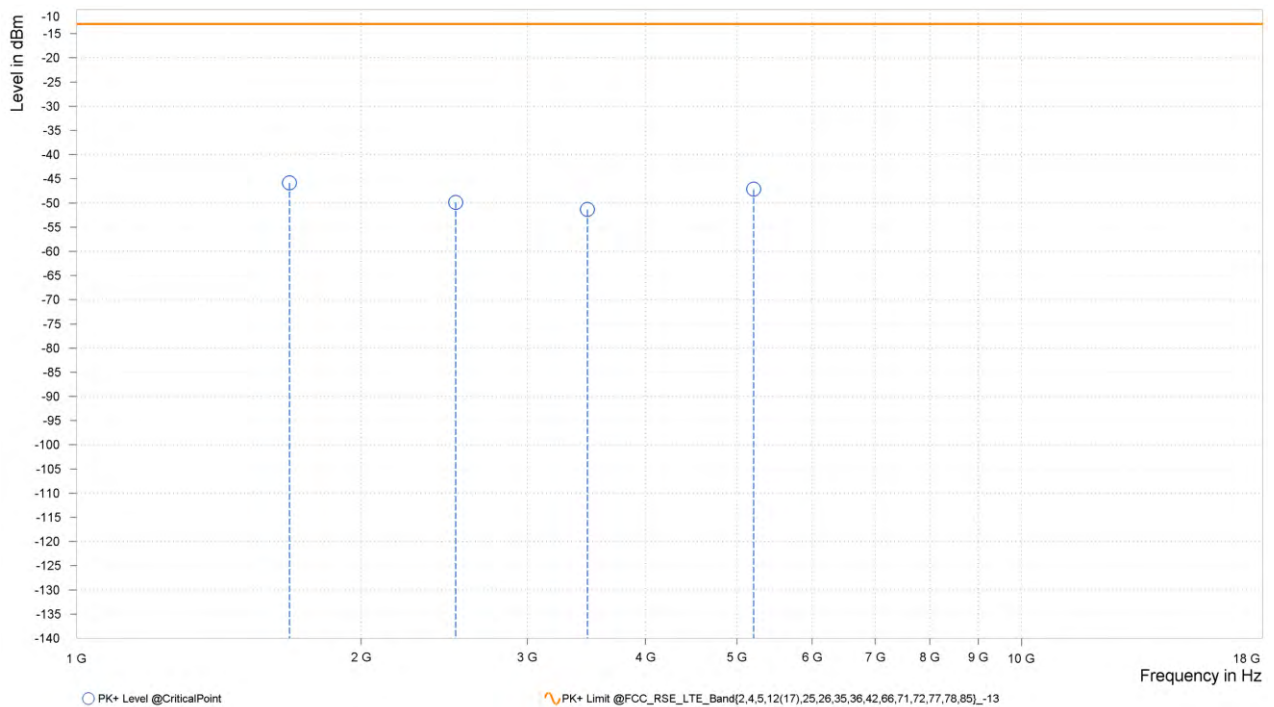



3.7 PEAK TO AVERAGE RATIO

3.7.1 LIMITS OF PEAK TO AVERAGE RATIO MEASUREMENT

In measuring transmissions in this band using an average power technique, the peak to-average ratio (PAR) of the transmission may not exceed 13 dB

3.7.2 TEST SETUP

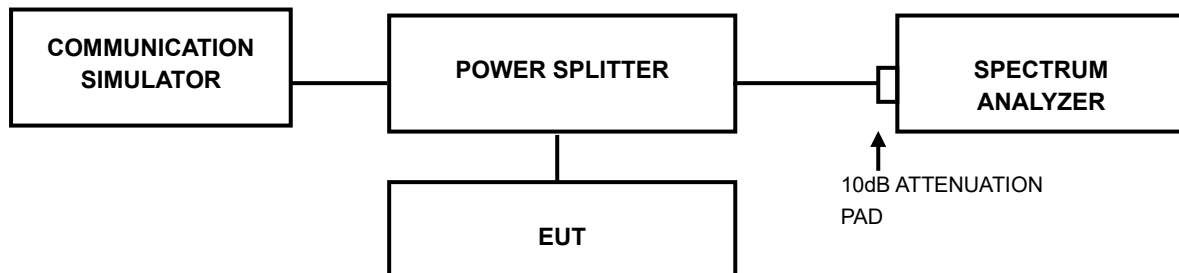

3.7.3 TEST PROCEDURES

1. Set resolution/measurement bandwidth \geq signal's occupied bandwidth;
2. Set the number of counts to a value that stabilizes the measured CCDF curve;
3. Record the maximum PAPR level associated with a probability of 0.1%.



Test Report No.: PSU-NQN2403180115RF05

3.7.4 TEST RESULTS

Please Refer to Appendix E Of this test report.



Test Report No.: PSU-NQN2403180115RF05

4 PHOTOGRAPHS OF THE TEST CONFIGURATION

Please refer to the attached file (Test Setup Photo).



**BUREAU
VERITAS**

Test Report No.: PSU-NQN2403180115RF05

5 INFORMATION ON THE TESTING LABORATORIES

We, BV 7LAYERS COMMUNICATIONS TECHNOLOGY (SHENZHEN) CO. LTD., were founded in 2015 to provide our best service in EMC, Radio, Telecom and Safety consultation. Our laboratories are accredited and approved according to ISO/IEC 17025.

If you have any comments, please feel free to contact us at the following:

Shenzhen EMC/RF Lab:

Tel: +86-755-88696566

Fax: +86-755-88696577

Email: customerservice.sw@bureauveritas.com

Web Site: www.adt.com.tw

The address and road map of all our labs can be found in our web site also.



Test Report No.: PSU-NQN2403180115RF05

6 MODIFICATIONS RECORDERS FOR ENGINEERING CHANGES TO THE EUT BY THE LAB

No any modifications are made to the EUT by the lab during the test.