



Test Report No.: PSU-NQN2403180115RF03



FCC TEST REPORT

(Part 15, Subpart E)



| | |
|------------|--|
| Applicant: | HMD Global Oy |
| Address: | Bertel Jungin aukio 9,02600 Espoo, Finland |

| | |
|---------------------------|--|
| Manufacturer or Supplier: | HMD Global Oy |
| Address: | Bertel Jungin aukio 9,02600 Espoo, Finland |
| Product: | Smart phone |
| Brand Name: | HMD |
| Model Name: | TA-1600/TA-1688 |
| FCC ID: | 2AJOTTA-1600 |
| Date of tests: | Apr. 08, 2024 ~ May. 31, 2024 |

The tests have been carried out according to the requirements of the following standard:

FCC Part 15, Subpart E, Section 15.407

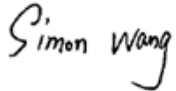
CONCLUSION: The submitted sample was found to COMPLY with the test requirement

| | |
|--|--|
| Prepared by Simon Wang Engineer / Mobile Department | Approved by Luke Lu Manager / Mobile Department |
|  Date: May. 31, 2024 |  Date: May. 31, 2024 |

This report is governed by, and incorporates by reference, the Conditions of Testing as posted at the date of issuance of this report at <http://www.bureauveritas.com/home/about-us/our-business/cps/about-us/terms-conditions/> and is intended for your exclusive use. Any copying or replication of this report to or for any other person or entity, or use of our name or trademark, is permitted only with our prior written permission. This report sets forth our findings solely with respect to the test samples identified herein. The results set forth in this report are not indicative or representative of the quality or characteristics of the lot from which a test sample was taken or any similar or identical product unless specifically and expressly noted. Our report includes all of the tests requested by you and the results thereof based upon the information that you provided to us. Measurement uncertainty is only provided upon request for accredited tests. Statements of conformity are based on simple acceptance criteria without taking measurement uncertainty into account, unless otherwise requested in writing. You have 60 days from date of issuance of this report to notify us of any material error or omission caused by our negligence or if you require measurement uncertainty; provided, however, that such notice shall be in writing and shall specifically address the issue you wish to raise. A failure to raise such issue within the prescribed time shall constitute your unqualified acceptance of the completeness of this report, the tests conducted and the correctness of the report contents.



TABLE OF CONTENTS

| | |
|--|-----------|
| RELEASE CONTROL RECORD | 4 |
| 1 SUMMARY OF TEST RESULTS..... | 5 |
| 1.1 MEASUREMENT UNCERTAINTY | 6 |
| 2 GENERAL INFORMATION | 7 |
| 2.1 GENERAL DESCRIPTION OF EUT | 7 |
| 2.2 DESCRIPTION OF TEST MODES | 11 |
| 2.2.1 TEST MODE APPLICABILITY AND TESTED CHANNEL DETAIL..... | 14 |
| 2.3 DUTY CYCLE OF TEST SIGNAL | 19 |
| 2.4 DESCRIPTION OF SUPPORT UNITS | 20 |
| 2.4.1 CONFIGURATION OF SYSTEM UNDER TEST | 21 |
| 2.5 GENERAL DESCRIPTION OF APPLIED STANDARDS | 22 |
| 3 TEST TYPES AND RESULTS..... | 23 |
| 3.4 RADIATED EMISSION AND BANDEDGE MEASUREMENT..... | 23 |
| 3.4.1 LIMITS OF RADIATED EMISSION AND BANDEDGE MEASUREMENT..... | 23 |
| 3.4.2 LIMITS OF UNWANTED EMISSION..... | 24 |
| 3.4.3 TEST INSTRUMENTS..... | 25 |
| 3.4.4 TEST PROCEDURES | 27 |
| 3.4.5 DEVIATION FROM TEST STANDARD | 27 |
| 3.4.6 TEST SETUP | 28 |
| 3.4.7 EUT OPERATING CONDITION | 29 |
| 3.4.8 TEST RESULTS | 30 |
| 3.5 CONDUCTED EMISSION MEASUREMENT | 466 |
| 3.5.1 LIMITS OF CONDUCTED EMISSION MEASUREMENT | 466 |
| 3.5.2 TEST INSTRUMENTS..... | 466 |
| 3.5.3 TEST PROCEDURES | 467 |
| 3.5.4 DEVIATION FROM TEST STANDARD | 468 |
| 3.5.5 TEST SETUP | 468 |
| 3.5.6 EUT OPERATING CONDITIONS | 468 |
| 3.5.7 TEST RESULTS | 469 |
| 3.6 MAXIMUM CONDUCTED OUTPUT POWER MEASUREMENT | 471 |
| 3.6.1 LIMITS OF MAXIMUM CONDUCTED OUTPUT POWER MEASUREMENT | 471 |
| 3.6.2 TEST SETUP | 472 |



| | | |
|----------|---|------------|
| 3.6.3 | TEST INSTRUMENTS..... | 473 |
| 3.6.4 | TEST PROCEDURE..... | 474 |
| 3.6.5 | DEVIATION FROM TEST STANDARD | 475 |
| 3.6.6 | EUT OPERATING CONDITIONS | 475 |
| 3.6.7 | TEST RESULTS | 476 |
| 3.7 | MAXIMUM POWER SPECTRAL DENSITY MEASUREMENT..... | 477 |
| 3.7.1 | LIMITS OF MAXIMUM POWER SPECTRAL DENSITY MEASUREMENT | 477 |
| 3.7.2 | TEST SETUP | 477 |
| 3.7.3 | TEST INSTRUMENTS..... | 477 |
| 3.7.4 | TEST PROCEDURES | 478 |
| 3.7.5 | DEVIATION FROM TEST STANDARD | 478 |
| 3.7.6 | EUT OPERATING CONDITIONS | 478 |
| 3.7.7 | TEST RESULTS | 479 |
| 3.8 | AUTOMATICALLY DISCONTINUE TRANSMISSION | 480 |
| 3.8.1 | LIMIT OF AUTOMATICALLY DISCONTINUE TRANSMISSION | 480 |
| 3.8.2 | TEST INSTRUMENTS..... | 480 |
| 3.8.3 | TEST RESULT | 480 |
| 3.9 | ANTENNA REQUIREMENTS..... | 481 |
| 3.9.1 | STANDARD APPLICABLE | 481 |
| 3.9.2 | ANTENNA CONNECTED CONSTRUCTION..... | 481 |
| 3.9.3 | ANTENNA GAIN | 482 |
| 4 | PHOTOGRAPHS OF THE TEST CONFIGURATION | 483 |
| 5 | MODIFICATIONS RECORDERS FOR ENGINEERING CHANGES TO THE EUT BY THE LAB484 | |



**BUREAU
VERITAS**

Test Report No.: PSU-NQN2403180115RF03

RELEASE CONTROL RECORD

| ISSUE NO. | REASON FOR CHANGE | DATE ISSUED |
|-----------------------|-------------------|---------------|
| PSU-NQN2403180115RF03 | Original release | May. 31, 2024 |



1 SUMMARY OF TEST RESULTS

The EUT has been tested according to the following specifications:

| APPLIED STANDARD: FCC PART 15, SUBPART E | | |
|--|---|------------|
| STANDARD SECTION | TEST TYPE AND LIMIT | RESULT |
| 15.407(b)(9) | AC Power Conducted Emission | Compliance |
| 15.407(b) (1/2/3/4/5) | Radiated Emission & Band Edge Measurement | Compliance |
| 15.407(a/1/2/3) | Maximum conducted output Power | Compliance |
| 15.407(a/1/2/3) | Peak Power Spectral Density | Compliance |
| 15.407(a)(2)(12) | 26 dB Bandwidth | Compliance |
| 15.407(e) | 6 dB Bandwidth | Compliance |
| 15.203 | Antenna Requirement | Compliance |

NOTE:

1. Except the data of RSE and Band Edge Measurement, other data please refer to Appendix C.
2. Preliminary Investigation scans were completed to compare Full RU Tone modes and Single User Tone modes. It was found that SU modes were the worst case over Full RU-Tone mode in every instance, and the physical waveforms of SU mode and FULL RU-Tone are the same, and both FULL RU-Tone mode have lower power than SU mode. Therefore, only SU mode was report as it is representative of Full RU-Tone worst case scenario.
3. RLAN 5G supports SISO&MIMO mode, the whole testing has assessed the MIMO mode by referring to their maximum conducted power. and the 802.11ax HE40/80MHz RU26T/52T/106T/242T modes are cover by the 11ax HE20MHz modes, the 802.11ax HE80MHz RU484T modes are cover by the 11ax HE40MHz modes.
4. For 802.11n HT20/ ac VHT20 and 802.11n HT40 / ac VHT40 mode, the whole testing is assessed only 802.11n HT20/ HT40 by referring to their higher conducted power.
5. Only the worse data was reported.

***Test Lab Information Reference**

Lab B:

Huarui 7Layers High Technology (Suzhou) Co., Ltd.

Lab Address:

Tower N, Innovation Center, 88 Zhuyi Road, High-tech District, Suzhou City, Anhui Province

Accredited Test Lab Cert 6613.01

The FCC Site Registration No. is 434559; The Designation No. is CN1325.



1.1 MEASUREMENT UNCERTAINTY

Where relevant, the following measurement uncertainty levels have been estimated for tests performed on the EUT as specified in CISPR 16-4-2:

| MEASUREMENT | UNCERTAINTY |
|-----------------------------------|-------------|
| AC Power Conducted emissions | ±2.70dB |
| Radiated emissions (9KHz~30MHz) | ±2.68dB |
| Radiated emissions (30MHz~1GHz) | ±4.98dB |
| Radiated emissions (1GHz ~6GHz) | ±4.70dB |
| Radiated emissions (6GHz ~18GHz) | ±4.60dB |
| Radiated emissions (18GHz ~40GHz) | ±4.12dB |
| Conducted emissions | ±4.01dB |
| Occupied Channel Bandwidth | ±43.58KHz |
| Conducted Output power | ±2.06dB |
| Power Spectral Density | ±0.85 dB |

This uncertainty represents an expanded uncertainty expressed at approximately the 95% confidence level using a coverage factor of $k = 2$.



2 GENERAL INFORMATION

2.1 GENERAL DESCRIPTION OF EUT

| | |
|----------------------------|--|
| PRODUCT | Smart phone |
| BRAND NAME | HMD |
| MODEL NAME | TA-1600/TA-1688 |
| NOMINAL VOLTAGE | 5.0Vdc/9.0Vdc /12.0Vdc(adapter) 3.89Vdc (battery) |
| MODULATION | OFDM, OFDMA |
| TRANSFER RATE | 802.11a: 54.0/ 48.0/ 36.0/ 24.0/ 18.0/ 12.0/ 9.0/ 6.0Mbps 802.11n: up to 300.0Mbps 802.11ac: up to 866.7Mbps 802.11ax: up to 1020.8Mbps |
| OPERATING FREQUENCY | 5180 ~ 5240MHz, 5260 ~ 5320MHz, 5500 ~ 5720MHz, 5745 ~ 5825MHz |
| NUMBER OF CHANNEL | 5180 ~ 5240MHz: 4 for 802.11a, 802.11n/ac/ax (20MHz)/ 802.11ax(20M RU 26/52/106/242) 2 for 802.11n/ac/ax (40MHz)/ 802.11ax(40M RU 484) 1 for 802.11ac/ax (80MHz)/ 802.11ax(80MRU996) 5260 ~ 5320MHz: 4 for 802.11a, 802.11n/ac/ax (20MHz)/ 802.11ax(20M RU 26/52/106/242) 2 for 802.11n/ac/ax (40MHz)/ 802.11ax(40M RU 484) 1 for 802.11ac/ax (80MHz)/ 802.11ax(80M RU 996) 5500 ~ 5720MHz: 12 for 802.11a, 802.11n/ac/ax (20MHz)/ 802.11ax(20M RU 26/52/106/242) 6 for 802.11n/ac/ax (40MHz)/ 802.11ax(40M RU 484) 3 for 802.11ac/ax (80MHz)/ 802.11ax(80M RU 996) 5745 ~ 5825MHz: 5 for 802.11a, 802.11n/ac/ax (20MHz)/ 802.11ax(20M RU 26/52/106/242) 2 for 802.11n/ac/ax (40MHz)/ 802.11ax(40M RU 484) 1 for 802.11ac/ax (80MHz)/ 802.11ax(80MRU 996) |
| MAX. OUTPUT POWER | 32.36mW for 5180 ~ 5240MHz |



| | |
|-----------------------|---|
| | 30.20mW for 5260 ~ 5320MHz 32.51mW for 5500 ~ 5720MHz 12.74mW for 5745 ~ 5825MHz |
| ANTENNA TYPE | PIFA Antenna |
| ANTENNA GAIN | ANT 8: -3dBi for 5180 ~ 5240MHz -3dBi for 5260 ~ 5320MHz -3dBi for 5500 ~ 5720MHz -3dBi for 5745 ~ 5825MHz ANT 11: -3dBi for 5180 ~ 5240MHz -3dBi for 5260 ~ 5320MHz -3dBi for 5500 ~ 5720MHz -3dBi for 5745 ~ 5825MHz |
| HW VERSION | V2 |
| SW VERSION | 00WW_0_340 |
| I/O PORTS | Refer to user's manual |
| CABLE SUPPLIED | N/A |

NOTE:

1. For a more detailed features description, please refer to the manufacturer's specifications or the user's manual.
2. The EUT incorporates a MIMO function. Physically, the EUT provides two completed transmitter and two receiver.

| MODULATION MODE | TX FUNCTION |
|---|--------------------|
| 802.11a | 2TX/2RX |
| 802.11n/802.11ac/ax (20MHz) | 2TX/2RX |
| 802.11n/802.11ac/ax (40MHz) | 2TX/2RX |
| 802.11ac/ax (80MHz) | 2TX/2RX |
| 802.11ax (20MHz RU 26/52/106/242) | 2TX/2RX |
| 802.11ax (40MHz RU 484) | 2TX/2RX |
| 802.11ax (80MHz RU 996) | 2TX/2RX |

3. For the test results, the EUT had been tested with all conditions. But only the worst case was shown in test report.
4. Antenna gain and EUT conducted cable loss are provided by the customer, and the laboratory will record the results based on these items that involve these two parameters.



5. List of Accessory:

| ACCESSORIES | BRAND | MANUFACTURER | MODEL | SPECIFICATION |
|----------------|----------|--------------|------------------------------|--|
| LCD Panel | BOE | BOE | BF066XMM-TL4-F900 | 6.55inch, AMOLED; |
| Back cover | BIEL | BIEL | Panda-X | 158 mm*73 mm*0.6 mm |
| Bezel | BIEL | BIEL | 6103HG02-T6 | 160 mm_76 mm_8.5 mm |
| Photo Camera 1 | AAC | AAC | P50AD01 | 50MP,AF |
| Photo Camera 2 | AAC | AAC | W13FD02 | 13MP Ultra Wide, FF |
| Video Camera 1 | AAC | AAC | T50AD01 | 50MP Tele, AF |
| Video Camera 2 | AAC | AAC | MA8SD01 | 108MP+OIS, AF |
| CPU | Qualcomm | Qualcomm | SM-7435-1-PSP1026-TR-00-0-AB | Platform Baseband Chip_PSP_mmW_8 core_SMT |
| eMMC1 (=ROM1) | Samsung | Samsung | KM8L9001JM-B624T07 | uMCP_254-ball FBGA_128GB_LPDD R4X_64Gb_SMT |
| eMMC2 (=ROM2) | Samsung | Samsung | KM8F9001JM-B813T07 | uMCP_254-ball FBGA_256GB_LPDD R4X_64Gb_SMT |
| eMMC3 (=ROM3) | Samsung | Samsung | KM8F9001MM-B830T07 | uMCP_254-ball FBGA_256GB_LPDD R4X_96Gb_SMT |
| Battery | HMD | Gaoyuan | HBA4633AA | RatedCapacity:4500mAh/17.51Wh |



6. The differences between the first and second supply as follows and the specifications and RF parameters are the same.

| Key Component list | | | | | | |
|--------------------|-------------------------------------|----------------------------|--------------|--|-----------------------|--|
| No. | Component | Description | First supply | | Second supply | |
| | | | Supplier | Spec | Supplier | Spec |
| 1 | USB/ Analog audio headsets | Analog Audio Switch | Dioo | DIO4480WL25 Analog switch & MUX_WLCSP25_2.7- 5.5V_3-Channel_1000MHz _SMT | Will | WAS4780C-25/TR Analog switch & MUX_CSP- 25L_2.7-5.5V_2- Channel_950MHz_ SMT |
| 2 | Wireless charge | Load Switch | SGM | SGM2575ADYG/TR Load Switch_34 mΩ_11 W_WLCSP_SGM2575ADY G/TR_SGM | Dioo | DIO7290WL4 Load Switch_85 mΩ_11 W_WLCSP-4 |
| 3 | Sensor | Barometer | Bosch | BMP580 Baroceptor_LGA-10_±0.05 hPa_48 bit_SMT | Go er mic ro | SPL07-003 Baroceptor_10pin LGA_0.5Pa/°C_24 bit_SMT |
| 4 | Sensor | eCOMPASS | VTC | AF6837 Magnetic field sensor_WLCSP_10 LSB/μT_16 bit_I2C_SMT | Memsic | MMC5603NJL Ecompass_MMC56 03NJL_M EMSIC_MCOs |
| 5 | RF IC | LNA | Will | WS7916DF-6/TR RF_LNA_6-pin DFN_1150 MHz to 1615_SMT | Awinic | AW5005EDNR RF_LNA_AW5005 EDNR_Awi nic |
| 6 | Receiver | SP2T | Will | WS78022D-6/TR DFN-6_0.1GHz - 3.8GHz_SPDT_GPIO_SMT | Champ hill | QX8612GD 0.7 to 2.7GHz_SPDT_2 W_GPIO |
| 7 | USB connector | USB type-C connector | LETCON | 15-16815-105-M1 USB TYPE C Connector_0.9 mm_16 pin_Female Head (elastic end)_Horizontal_None- waterproof_4.27 mm_Gold_SMT_480M | HRD | UC141-0B100DR0 USB TYPE C Connector_0.9 mm_16 pin_Female Head (elastic end)_Horizontal_No ne- waterproof_4.3 mm_Gold_SMT_48 0M |



2.2 DESCRIPTION OF TEST MODES

FOR 5180 ~ 5240MHz

4 channels are provided for 802.11a, 802.11n, 802.11ac/ax (20MHz)/ 802.11ax (20MHz RU 26/52/106/242):

| CHANNEL | FREQUENCY | CHANNEL | FREQUENCY |
|---------|-----------|---------|-----------|
| 36 | 5180 MHz | 44 | 5220 MHz |
| 40 | 5200 MHz | 48 | 5240 MHz |

2 channels are provided for 802.11n, 802.11ac/ax (40MHz)/ 802.11ax (40MHz RU 484):

| CHANNEL | FREQUENCY | CHANNEL | FREQUENCY |
|---------|-----------|---------|-----------|
| 38 | 5190 MHz | 46 | 5230 MHz |

1 channel is provided for 802.11ac/ax (80MHz)/ 802.11ax (80MHz RU 996):

| CHANNEL | FREQUENCY | CHANNEL | FREQUENCY |
|---------|-----------|---------|-----------|
| 42 | 5210 MHz | | |

FOR 5260 ~ 5320MHz

4 channels are provided for 802.11a, 802.11n, 802.11ac/ax (20MHz)/ 802.11ax (20MHz RU 26/52/106/242):

| CHANNEL | FREQUENCY | CHANNEL | FREQUENCY |
|---------|-----------|---------|-----------|
| 52 | 5260 MHz | 60 | 5300 MHz |
| 56 | 5280 MHz | 64 | 5320 MHz |

2 channels are provided for 802.11n, 802.11ac/ax (40MHz)/ 802.11ax (40MHz RU 484):

| CHANNEL | FREQUENCY | CHANNEL | FREQUENCY |
|---------|-----------|---------|-----------|
| 54 | 5270 MHz | 62 | 5310 MHz |

1 channel is provided for 802.11ac/ax (80MHz)/ 802.11ax (80MHz RU 996):

| CHANNEL | FREQUENCY | CHANNEL | FREQUENCY |
|---------|-----------|---------|-----------|
| 58 | 5290 MHz | | |



FOR 5500 ~ 5720MHz

12 channels are provided for 802.11a, 802.11n, 802.11ac/ax (20MHz)/ 802.11ax (20MHz RU 26/52/106/242):

| CHANNEL | FREQUENCY | CHANNEL | FREQUENCY |
|---------|-----------|---------|-----------|
| 100 | 5500 MHz | 124 | 5620MHz |
| 104 | 5520 MHz | 128 | 5640MHz |
| 108 | 5540 MHz | 132 | 5660 MHz |
| 112 | 5560 MHz | 136 | 5680 MHz |
| 116 | 5580 MHz | 140 | 5700 MHz |
| 120 | 5600 MHz | 144 | 5720 MHz |

6 channels are provided for 802.11n, 802.11ac/ax (40MHz)/ 802.11ax (40MHz RU 484):

| CHANNEL | FREQUENCY | CHANNEL | FREQUENCY |
|---------|-----------|---------|-----------|
| 102 | 5510 MHz | 126 | 5630MHz |
| 110 | 5550 MHz | 134 | 5670 MHz |
| 118 | 5590 MHz | 142 | 5710 MHz |

3 channel is provided for 802.11ac/ax (80MHz)/ 802.11ax (80MHz RU 996):

| CHANNEL | FREQUENCY | CHANNEL | FREQUENCY |
|---------|-----------|---------|-----------|
| 106 | 5530 MHz | 122 | 5610 MHz |
| 138 | 5690 MHz | | |



FOR 5745 ~ 5825MHz

5 channels are provided for 802.11a, 802.11n, 802.11ac/ax (20MHz)/ 802.11ax (20MHz RU 26/52/106/242):

| CHANNEL | FREQUENCY | CHANNEL | FREQUENCY |
|---------|-----------|---------|-----------|
| 149 | 5745 MHz | 161 | 5805 MHz |
| 153 | 5765 MHz | 165 | 5825 MHz |
| 157 | 5785 MHz | | |

3 channels are provided for 802.11n, 802.11ac/ax (40MHz)/ 802.11ax (40MHz RU 484):

| CHANNEL | FREQUENCY | CHANNEL | FREQUENCY |
|---------|-----------|---------|-----------|
| 142 | 5710 MHz | 159 | 5795 MHz |
| 151 | 5755 MHz | | |

2 channel is provided for 802.11ac/ax (80MHz)/ 802.11ax (80MHz RU 996):

| CHANNEL | FREQUENCY | CHANNEL | FREQUENCY |
|---------|-----------|---------|-----------|
| 138 | 5690 MHz | 155 | 5775 MHz |



2.2.1 TEST MODE APPLICABILITY AND TESTED CHANNEL DETAIL

| EUT CONFIGURE MODE | APPLICABLE TO | | | | DESCRIPTION |
|--------------------|---------------|-------|-----|------|---------------------------------------|
| | RE≥1G | RE<1G | PLC | APCM | |
| A | √ | √ | √ | - | Powered by Adapter with wifi(5G) link |
| B | - | - | - | √ | Powered by Battery with wifi(5G) link |
| C | - | - | - | - | Powered by USB with wifi(5G) link |

Where **RE≥1G**: Radiated Emission above 1GHz **RE<1G**: Radiated Emission below 1GHz
PLC: Power Line Conducted Emission **APCM**: Antenna Port Conducted Measurement

NOTE:
The EUT had been pre-tested on the positioned of each 3 axis. The worst case was found when positioned on **X-plane**.
NOTE: “-” means no effect

RADIATED EMISSION TEST (BELOW 1GHz):

- Pre-Scan has been conducted to determine the worst-case mode from all possible combinations between available modulations, data rates and antenna ports (if EUT with antenna diversity architecture).
- The following channel(s) was (were) selected for the final test as listed below.

| EUT CONFIGURE MODE | MODE | FREQ. BAND (MHz) | AVAILABLE CHANNEL | TESTED CHANNEL | MODULATION | DATA RATE (Mbps) |
|--------------------|-----------------|------------------|-------------------|----------------|------------|------------------|
| A | 802.11ac(80MHz) | 5500-5720 | 106 to 138 | 138 | OFDM | MCS0 |



RADIATED EMISSION TEST (ABOVE 1GHz):

- Pre-Scan has been conducted to determine the worst-case mode from all possible combinations between available modulations, data rates and antenna ports (if EUT with antenna diversity architecture).
- The following channel(s) was (were) selected for the final test as listed below.

| EUT CONFIGURE MODE | MODE | FREQ. BAND (MHz) | AVAILABLE CHANNEL | TESTED CHANNEL | MODULATION | DATA RATE (Mbps) |
|--------------------|---|------------------|-------------------|--------------------|-------------|------------------|
| A | 802.11a | 5180-5240 | 36 to 48 | 36, 40, 48 | OFDM | 6.0 |
| A | 802.11n/ax (20MHz)/ 802.11ax (20MHz RU 26/52/106) | | 36 to 48 | 36, 40, 48 | OFDM, OFDMA | MCS0 |
| A | 802.11n/ax (40MHz) | | 38 to 46 | 38, 46 | OFDM, OFDMA | MCS0 |
| A | 802.11ac/ax (80MHz) | | 42 | 42 | OFDM, OFDMA | MCS0 |
| A | 802.11a | 5260-5320 | 52 to 64 | 52, 60, 64 | OFDM | 6.0 |
| A | 802.11n/ax (20MHz)/ 802.11ax (20MHz RU 26/52/106) | | 52 to 64 | 52, 60, 64 | OFDM, OFDMA | MCS0 |
| A | 802.11n/ax (40MHz) | | 54 to 62 | 54, 62 | OFDM, OFDMA | MCS0 |
| A | 802.11ac/ax (80MHz) | | 58 | 58 | OFDM, OFDMA | MCS0 |
| A | 802.11a | 5500-5720 | 100 to 144 | 100, 116, 140, 144 | OFDM | 6.0 |
| A | 802.11n/ax (20MHz)/ 802.11ax (20MHz RU 26/52/106) | | 100 to 144 | 100, 116, 140, 144 | OFDM, OFDMA | MCS0 |
| A | 802.11n/ax (40MHz) | | 102 to 142 | 102, 110, 134, 142 | OFDM, OFDMA | MCS0 |
| A | 802.11ac/ax (80MHz) | | 106 to 138 | 106, 122, 138 | OFDM, OFDMA | MCS0 |
| A | 802.11a | 5745-5825 | 149 to 165 | 149, 157, 165 | OFDM | 6.0 |
| A | 802.11n/ax (20MHz)/ 802.11ax (20MHz RU 26/52/106) | | 149 to 165 | 149, 157, 165 | OFDM, OFDMA | MCS0 |
| A | 802.11n/ax (40MHz) | | 151 to 159 | 151, 159 | OFDM, OFDMA | MCS0 |
| A | 802.11ac/ax (80MHz) | | 155 | 155 | OFDM, OFDMA | MCS0 |



POWER LINE CONDUCTED EMISSION TEST:

- Pre-Scan has been conducted to determine the worst-case mode from all possible combinations between available modulations, data rates and antenna ports (if EUT with antenna diversity architecture).
- The following channel(s) was (were) selected for the final test as listed below.

| EUT CONFIGURE MODE | MODE | FREQ. BAND (MHz) | AVAILABLE CHANNEL | TESTED CHANNEL | MODULATION | DATA RATE (Mbps) |
|--------------------|-----------------|------------------|-------------------|----------------|------------|------------------|
| A | 802.11ac(80MHz) | 5500-5720 | 106 to 138 | 138 | OFDM | MCS0 |

BANDEDGE MEASUREMENT:

- Pre-Scan has been conducted to determine the worst-case mode from all possible combinations between available modulations, data rates and antenna ports (if EUT with antenna diversity architecture).
- The following channel(s) was (were) selected for the final test as listed below.

| EUT CONFIGURE MODE | MODE | FREQ. BAND (MHz) | AVAILABLE CHANNEL | TESTED CHANNEL | MODULATION | DATA RATE (Mbps) |
|--------------------|---|------------------|-------------------|--------------------|-------------|------------------|
| A | 802.11a | 5180-5240 | 36 to 48 | 36, 40, 48 | OFDM | 6.0 |
| A | 802.11n/ax (20MHz)/ 802.11ax (20MHz RU 26/52/106) | | 36 to 48 | 36, 40, 48 | OFDM, OFDMA | MCS0 |
| A | 802.11n/ax (40MHz) | | 38 to 46 | 38, 46 | OFDM, OFDMA | MCS0 |
| A | 802.11ac/ax (80MHz) | | 42 | 42 | OFDM, OFDMA | MCS0 |
| A | 802.11a | 5260-5320 | 52 to 64 | 52, 60, 64 | OFDM | 6.0 |
| A | 802.11n/ax (20MHz)/ 802.11ax (20MHz RU 26/52/106) | | 52 to 64 | 52, 60, 64 | OFDM, OFDMA | MCS0 |
| A | 802.11n/ax (40MHz) | | 54 to 62 | 54, 62 | OFDM, OFDMA | MCS0 |
| A | 802.11ac/ax (80MHz) | | 58 | 58 | OFDM, OFDMA | MCS0 |
| A | 802.11a | 5500-5720 | 100 to 144 | 100, 116, 140, 144 | OFDM | 6.0 |
| A | 802.11n/ax (20MHz)/ 802.11ax (20MHz RU 26/52/106) | | 100 to 144 | 100, 116, 140, 144 | OFDM, OFDMA | MCS0 |
| A | 802.11n/ax (40MHz) | | 102 to 142 | 102, 110, 134,142 | OFDM, OFDMA | MCS0 |
| A | 802.11ac/ax (80MHz) | | 106 to 138 | 106, 122, 138 | OFDM, OFDMA | MCS0 |
| A | 802.11a | 5745-5825 | 149 to 165 | 149, 157,165 | OFDM | 6.0 |
| A | 802.11n/ax (20MHz)/ 802.11ax (20MHz RU 26/52/106) | | 149 to 165 | 149, 157,165 | OFDM, OFDMA | MCS0 |
| A | 802.11n/ax (40MHz) | | 151 to 159 | 151, 159 | OFDM, OFDMA | MCS0 |
| A | 802.11ac/ax (80MHz) | | 155 | 155 | OFDM, OFDMA | MCS0 |



ANTENNA PORT CONDUCTED MEASUREMENT:

- Pre-Scan has been conducted to determine the worst-case mode from all possible combinations between available modulations, data rates and antenna ports (if EUT with antenna diversity architecture).
- The following channel(s) was (were) selected for the final test as listed below.
- Only the power test item is tested for the FULL RU(802.11ax RU 242/484/996), the remaining test items are configured as follows.

| EUT CONFIGURE MODE | MODE | FREQ. BAND (MHz) | AVAILABLE CHANNEL | TESTED CHANNEL | MODULATION | DATA RATE (Mbps) |
|--------------------|--|------------------|-------------------|--------------------|-------------|------------------|
| A | 802.11a | 5180-5240 | 36 to 48 | 36, 40, 48 | OFDM | 6.0 |
| A | 802.11n/ax (20MHz)/ 802.11ax (20MHz RU 26/52/106) | | 36 to 48 | 36, 40, 48 | OFDM, OFDMA | MCS0 |
| A | 802.11n/ax (40MHz) | | 38 to 46 | 38, 46 | OFDM, OFDMA | MCS0 |
| A | 802.11ac/ax (80MHz) | | 42 | 42 | OFDM, OFDMA | MCS0 |
| A | 802.11a | 5260-5320 | 52 to 64 | 52, 60, 64 | OFDM | 6.0 |
| A | 802.11n/ax (20MHz)/ 802.11ax (20MHz RU 26/52/106) | | 52 to 64 | 52, 60, 64 | OFDM, OFDMA | MCS0 |
| A | 802.11n/ax (40MHz) | | 54 to 62 | 54, 62 | OFDM, OFDMA | MCS0 |
| A | 802.11ac/ax (80MHz) | | 58 | 58 | OFDM, OFDMA | MCS0 |
| A | 802.11a | 5500-5720 | 100 to 144 | 100, 116, 140, 144 | OFDM | 6.0 |
| A | 802.11n/ax (20MHz)/ 802.11ax (20MHz RU 26/52/106) | | 100 to 144 | 100, 116, 140, 144 | OFDM, OFDMA | MCS0 |
| A | 802.11n/ax (40MHz) | | 102 to 142 | 102, 110, 134,142 | OFDM, OFDMA | MCS0 |
| A | 802.11ac/ax (80MHz) | | 106 to 138 | 106, 122, 138 | OFDM, OFDMA | MCS0 |
| A | 802.11a | 5745-5825 | 149 to 165 | 149, 157,165 | OFDM | 6.0 |
| A | 802.11n/ax (20MHz)/ 802.11ax (20MHz RU 26/52/106) | | 149 to 165 | 149, 157,165 | OFDM, OFDMA | MCS0 |
| A | 802.11n/ax (40MHz) | | 151 to 159 | 151, 159 | OFDM, OFDMA | MCS0 |
| A | 802.11ac/ax (80MHz) | | 155 | 155 | OFDM, OFDMA | MCS0 |



TEST CONDITION:

| APPLICABLE TO | ENVIRONMENTAL CONDITIONS | INPUT POWER | TESTED BY |
|---------------|--------------------------|--------------------------------|-----------|
| RE<1G | 23deg. C, 70%RH | DC5.0V/ 9.0V /12.0V By Adapter | Jace Hu |
| RE≥1G | 23deg. C, 70%RH | DC5.0V/ 9.0V /12.0V By Adapter | Jace Hu |
| PLC | 25deg. C, 52%RH | DC5.0V/ 9.0V /12.0V By Adapter | James Fu |
| APCM | 25deg. C, 60%RH | DC 3.89V By Battery | James Fu |



Test Report No.: PSU-NQN2403180115RF03

2.3 DUTY CYCLE OF TEST SIGNAL

Please Refer to Appendix C Of this test report.



2.4 DESCRIPTION OF SUPPORT UNITS

The EUT has been tested as an independent unit together with other necessary accessories or support units. The following support units or accessories were used to form a representative test configuration during the tests.

| NO. | PRODUCT | BRAND | MODEL NO. | SERIAL NO. | FCC ID |
|-----|---------|--------|--------------|------------|--------|
| 1 | Laptop | Lenovo | Thinkpad E14 | SL10W47313 | N/A |
| 2 | Adapter | N/A | N/A | N/A | N/A |

| NO. | SIGNAL CABLE DESCRIPTION OF THE ABOVE SUPPORT UNITS |
|-----|---|
| 1 | AC Line: Unshielded, Detachable 1.5m |
| 2 | USB Line: Unshielded, Detachable, 1.0m; |



2.4.1 CONFIGURATION OF SYSTEM UNDER TEST

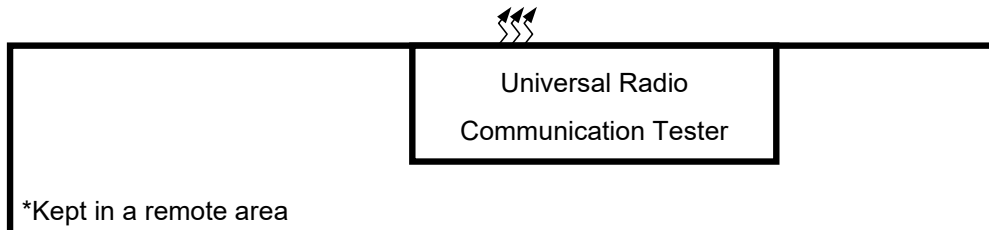
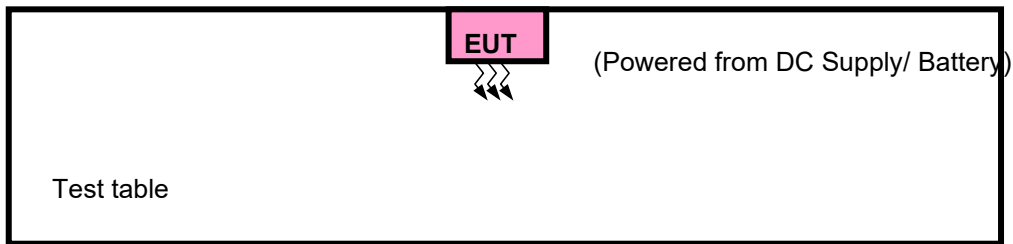
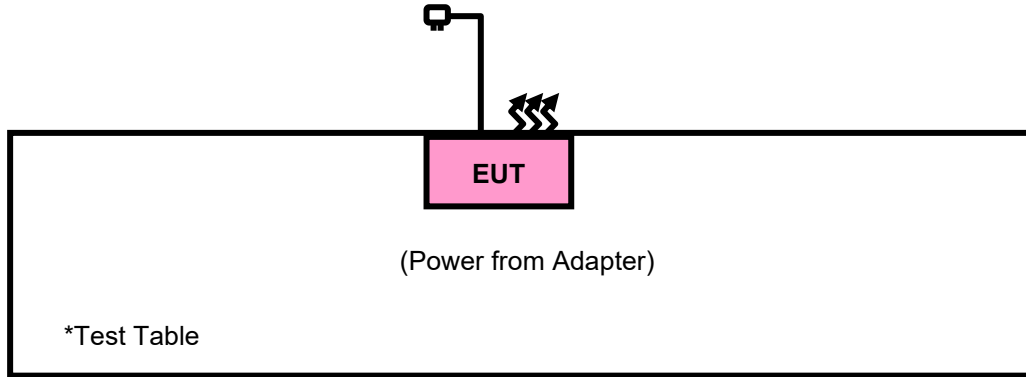



Test Report No.: PSU-NQN2403180115RF03

2.5 GENERAL DESCRIPTION OF APPLIED STANDARDS

The EUT is a RF Product. According to the specifications of the manufacturer, it must comply with the requirements of the following standards:

FCC Part 15, Subpart E (15.407)

KDB 789033 D02 General U-NII Test Procedures New Rules v02r01

ANSI C63.10-2020

All test items have been performed and recorded as per the above standards.

NOTE: The EUT is also considered as a kind of computer peripheral, because the connection to computer is necessary for typical use. It has been verified to comply with the requirements of FCC Part 15, Subpart B, Class B (Certification). The test report has been issued separately.



3 TEST TYPES AND RESULTS

3.4 RADIATED EMISSION AND BANDEDGE MEASUREMENT

3.4.1 LIMITS OF RADIATED EMISSION AND BANDEDGE MEASUREMENT

Radiated emissions which fall in the restricted bands must comply with the radiated emission limits specified as below table:

| FREQUENCIES (MHz) | FIELD STRENGTH (microvolts/meter) | MEASUREMENT DISTANCE (meters) |
|-------------------|-----------------------------------|-------------------------------|
| 0.009 ~ 0.490 | 2400/F(kHz) | 300 |
| 0.490 ~ 1.705 | 24000/F(kHz) | 30 |
| 1.705 ~ 30.0 | 30 | 30 |
| 30 ~ 88 | 100 | 3 |
| 88 ~ 216 | 150 | 3 |
| 216 ~ 960 | 200 | 3 |
| Above 960 | 500 | 3 |

NOTE:

1. The lower limit shall apply at the transition frequencies.
2. Emission level (dBuV/m) = 20 log Emission level (uV/m).
3. For frequencies above 1000MHz, the field strength limits are based on average detector, however, the peak field strength of any emission shall not exceed the maximum permitted average limits, specified above by more than 20dB under any condition of modulation.



3.4.2 LIMITS OF UNWANTED EMISSION

| RESTRICTED BANDS | APPLICABLE TO | LIMIT | |
|-----------------------------|--|-------------------------------|--|
| | 789033 D02 General UNII Test Procedures New Rules v02r01 | FIELD STRENGTH AT 3m (dBµV/m) | |
| | | PK : 74 | AV : 54 |
| OUT OF THE RESTRICTED BANDS | APPLICABLE TO | EIRP LIMIT (dBm/MHz) | EQUIVALENT FIELD STRENGTH AT 3m (dBµV/m) |
| | 15.407(b)(1) | PK : -27 | PK : 68.2 |
| | 15.407(b)(2) | | |
| | 15.407(b)(3) | | |
| | 15.407(b)(4) | See note 2 (FCC 16-24) | |

NOTE: The following formula is used to convert the equipment isotropic radiated power (eirp) to field strength:

$$E = \frac{1000000\sqrt{30P}}{3} \mu\text{V/m, where P is the eirp (Watts).}$$

2. All emissions shall be limited to a level of -27 dBm/MHz at 75 MHz or more above or below the band edge increasing linearly to 10 dBm/MHz at 25 MHz above or below the band edge, and from 25 MHz above or below the band edge increasing linearly to a level of 15.6 dBm/MHz at 5 MHz above or below the band edge, and from 5 MHz above or below the band edge increasing linearly to a level of 27 dBm/MHz at the band edge.

**3.4.3 TEST INSTRUMENTS**

| Equipment | Manufacturer | Model No. | Serial No. | Last Cal. | Next Cal. |
|------------------------------------|------------------------------|------------------|-----------------------|------------------|------------------|
| Pre-Amplifier | R&S | SCU18F1 | 100815 | Aug.30,22 | Aug.29,24 |
| Pre-Amplifier | R&S | SCU08F1 | 101028 | Sep.16,22 | Sep.15,24 |
| Signal Generator | R&S | SMB100A | 182185 | Feb.15,24 | Feb.14,26 |
| 3m Fully-anechoic Chamber | TDK | 9m*6m*6m | HRSW-SZ-EMC-01Chamber | Nov.25,22 | Nov.24,25 |
| 3m Semi-anechoic Chamber | TDK | 9m*6m*6m | HRSW-SZ-EMC-02Chamber | Nov.25,22 | Nov.24,25 |
| EMI TEST Receiver | R&S | ESW44 | 101973 | Feb.24,24 | Feb.23,26 |
| Bilog Antenna | SCHWARZBECK | VULB 9163 | 1264 | Feb.27,24 | Feb.26,26 |
| Horn Antenna | ETS-LINDGREN | 3117 | 227836 | Aug.22,22 | Aug.21,24 |
| Horn Antenna (18GHz-40GHz) | Steatite Q-par Antennas | QMS 00880 | 23486 | Feb.22,24 | Feb.21,26 |
| Horn Antenna | Steatite Q-par Antennas | QMS 00208 | 23485 | Aug.22,22 | Aug.21,24 |
| Loop Antenna | SCHWARZ | HFH2-Z2/Z2E | 100976 | Feb.22,24 | Feb.21,26 |
| WIDEBANDRADIO COMMUNICATION TESTER | R&S | CMW500 | 169399 | Jun.27,22 | Jun.26,24 |
| Test Software | ELEKTRA | ELEKTRA4.32 | N/A | N/A | N/A |
| Open Switch and Control Unit | R&S | OSP220 | 101964 | N/A | N/A |
| DC Source | HYELEC | HY3010B | 551016 | Aug.31,22 | Aug.30,24 |
| Hygrothermograph | DELI | 20210528 | SZ014 | Sep.06,22 | Sep.05,24 |
| 6DB attenuator | Tonscend Technology Co., Ltd | N/A | 23062787 | N/A | N/A |
| PC | LENOVO | E14 | HRSW0024 | N/A | N/A |
| TMC-AMI18843A(CABLE) | R&S | HF290-NMNM-7.00M | N/A | N/A | N/A |
| TMC-AMI18843A(CABLE) | R&S | HF290-NMNM-4.00M | N/A | N/A | N/A |
| CABLE | R&S | W13.02 | N/A | Apr.28,23 | Apr.27,24 |
| CABLE | R&S | W13.02 | N/A | Apr.27,24 | Apr.26,26 |
| CABLE | R&S | W12.14 | N/A | Apr.28,23 | Apr.27,24 |
| CABLE | R&S | W12.14 | N/A | Apr.27,24 | Apr.26,26 |



Test Report No.: PSU-NQN2403180115RF03

- NOTE:**
1. The calibration interval of the above test instruments is 12/ 24 / 36 months and the calibrations are traceable to CEPREI/CHINA, GRGT/CHINA and NIM/CHINA.
 2. The test was performed in 3m Chamber.
 3. The FCC Site Registration No. is 434559; The Designation No. is CN1325.



3.4.4 TEST PROCEDURES

- a. The EUT was placed on the top of a rotating table 0.8 meters (for below 1GHz) / 1.5 meters (for above 1GHz) above the ground at 3-meter chamber room for test. The table was rotated 360 degrees to determine the position of the highest radiation.
- b. The EUT was set 3 meters away from the interference-receiving antenna, which was mounted on the top of a variable-height antenna tower.
- c. The antenna is a broadband antenna, and its height is varied from one meter to four meters above the ground to determine the maximum value of the field strength. Both horizontal and vertical polarizations of the antenna are set to make the measurement.
- d. For each suspected emission, the EUT was arranged to its worst case and then the antenna was tuned to heights from 1 meter to 4 meters and the rotatable table was turned from 0 degrees to 360 degrees to find the maximum reading.
- e. The test-receiver system was set to Peak Detect Function and Specified Bandwidth with Maximum Hold Mode.
- f. If the emission level of the EUT in peak mode was 10dB lower than the limit specified, then testing could be stopped and the peak values of the EUT would be reported. Otherwise, the emissions that did not have 10dB margin would be re-tested one by one using peak, quasi-peak or average method as specified and then reported in a data sheet.

NOTE:

1. The resolution bandwidth and video bandwidth of test receiver/spectrum analyzer is 120kHz for Peak detection (PK) and Quasi-peak detection (QP) at frequency below 1GHz.
2. The resolution bandwidth of test receiver/spectrum analyzer is 1MHz and video bandwidth is 3MHz for Peak detection at frequency above 1GHz.
3. The resolution bandwidth of test receiver/spectrum analyzer is 1MHz and the video bandwidth is 3MHz for RMS Average (Duty cycle < 98%) for Average detection (AV) at frequency above 1GHz, then the measurement results was added to a correction factor ($10 \log(1/\text{duty cycle})$).
4. The resolution bandwidth of test receiver/spectrum analyzer is 1MHz and the video bandwidth is 10Hz (Duty cycle \geq 98%) for Average detection (AV) at frequency above 1GHz.
5. All modes of operation were investigated, and the worst-case emissions are reported.

3.4.5 DEVIATION FROM TEST STANDARD

No deviation.



3.4.6 TEST SETUP

<Frequency Range 9KHz~30MHz >

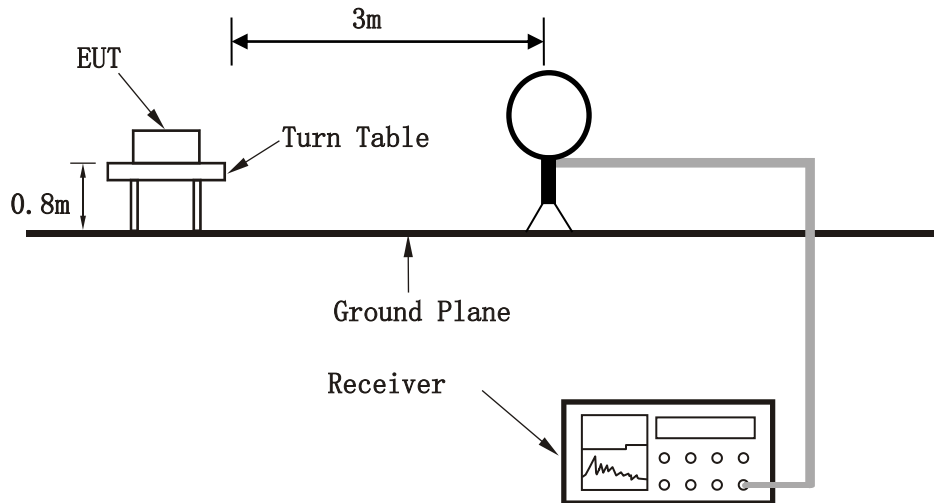

< Frequency Range 30MHz~1GHz >

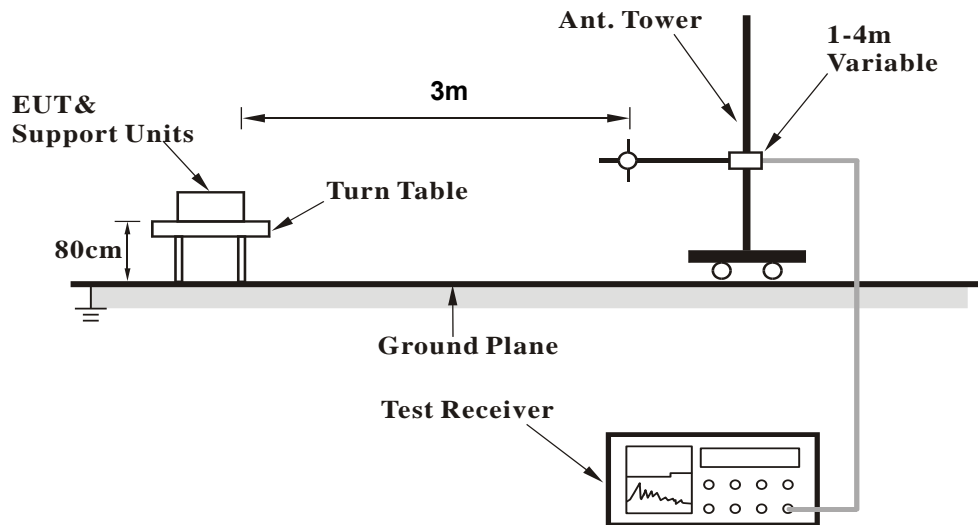



<Frequency Range above 1GHz>

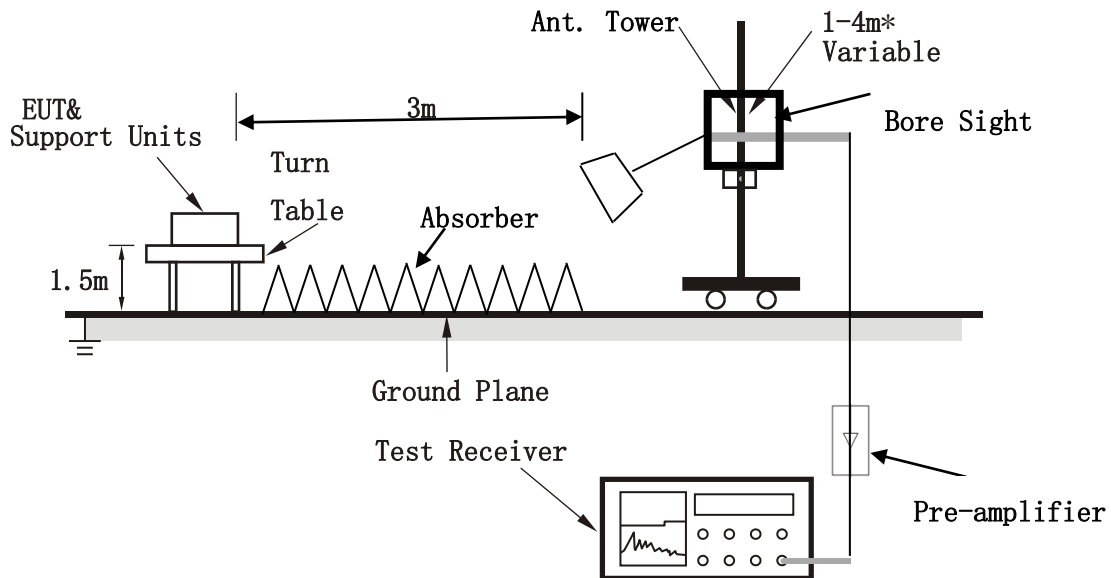

Note: Above 1G is a directional antenna

Depends on the EUT height and the antenna 3dB beamwidth both, refer to section 7.3 of CISPR 16-2-3.

For the actual test configuration, please refer to the attached file (Test Setup Photo).

3.4.7 EUT OPERATING CONDITION

- Set the EUT under full load condition and placed them on a testing table.
- Set the transmitter part of EUT under transmission condition continuously at specific channel frequency.
- The necessary accessories enable the EUT in full functions.



3.4.8 TEST RESULTS

NOTE : The 9K~30MHz amplitude of spurious emissions attenuated more than 20 dB below the permissible value is not required in the report.

BAND EDGE MEASUREMENT

Band 1
802.11a

| | | | |
|------------------------|---------------|--------------------------|--------------|
| CHANNEL | TX Channel 36 | DETECTOR FUNCTION | Peak (PK) |
| FREQUENCY RANGE | 1GHz ~ 40GHz | | Average (AV) |

ANTENNA POLARITY & TEST DISTANCE: HORIZONTAL AT 3 M

| Rg | Frequency [MHz] | PK+ Level [dBμV/m] | PK+ Limit [dBμV/m] | PK+ Margin [dB] | Correction [dB] | Polarization | Azimuth [deg] | Antenna Height [m] |
|----|-----------------|--------------------|--------------------|-----------------|-----------------|--------------|---------------|--------------------|
| 1 | 5,110.500 | 50.48 | 74.00 | 23.52 | 10.71 | H | 351.8 | 1.00 |
| 1 | 5,150.000 | 49.86 | 74.00 | 24.14 | 10.77 | H | 84.1 | 1.00 |
| 1 | 5,177.000 | 96.31 | | | 10.86 | H | 180.2 | 2.00 |

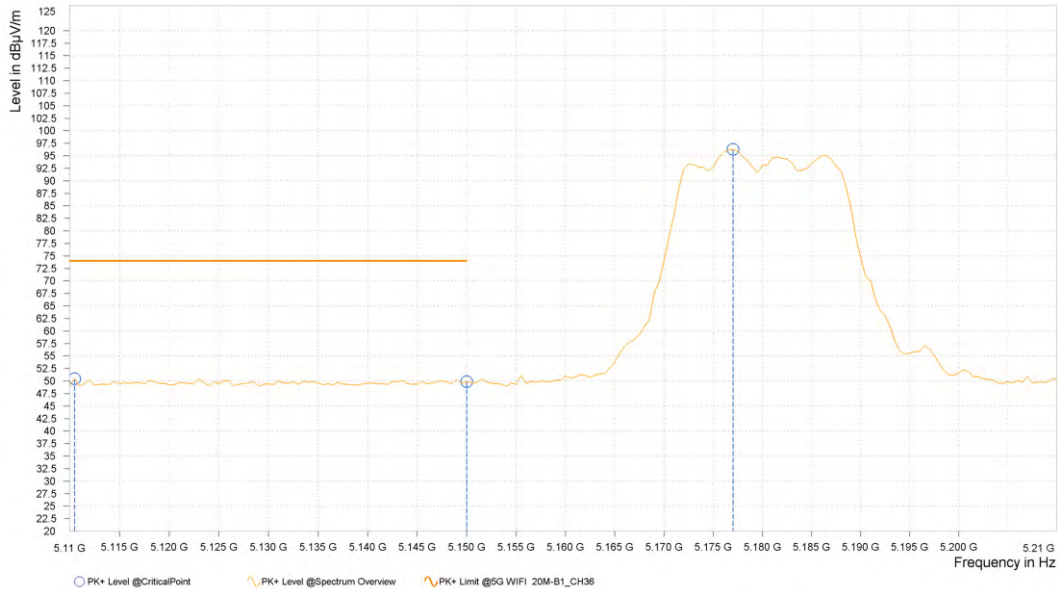



| Rg | Frequency [MHz] | AVG Level [dBμV/m] | AVG Limit [dBμV/m] | AVG Margin [dB] | Correction [dB] | Polarization | Azimuth [deg] | Antenna Height [m] |
|----|-----------------|--------------------|--------------------|-----------------|-----------------|--------------|---------------|--------------------|
| 1 | 5,111.000 | 35.39 | 54.00 | 18.61 | 10.72 | H | 134.4 | 1.00 |
| 1 | 5,150.000 | 35.50 | 54.00 | 18.50 | 10.77 | H | 6.2 | 2.00 |
| 1 | 5,177.000 | 82.21 | | | 10.86 | H | 179 | 2.00 |





ANTENNA POLARITY & TEST DISTANCE: VERTICAL AT 3 M

| Rg | Frequency [MHz] | PK+ Level [dBμV/m] | PK+ Limit [dBμV/m] | PK+ Margin [dB] | Correction [dB] | Polarization | Azimuth [deg] | Antenna Height [m] |
|----|-----------------|--------------------|--------------------|-----------------|-----------------|--------------|---------------|--------------------|
| 1 | 5,116.500 | 50.42 | 74.00 | 23.58 | 10.72 | V | 359 | 1.00 |
| 1 | 5,150.000 | 49.85 | 74.00 | 24.15 | 10.77 | V | 0.9 | 2.00 |
| 1 | 5,177.500 | 96.98 | | | 10.86 | V | 226.5 | 1.00 |

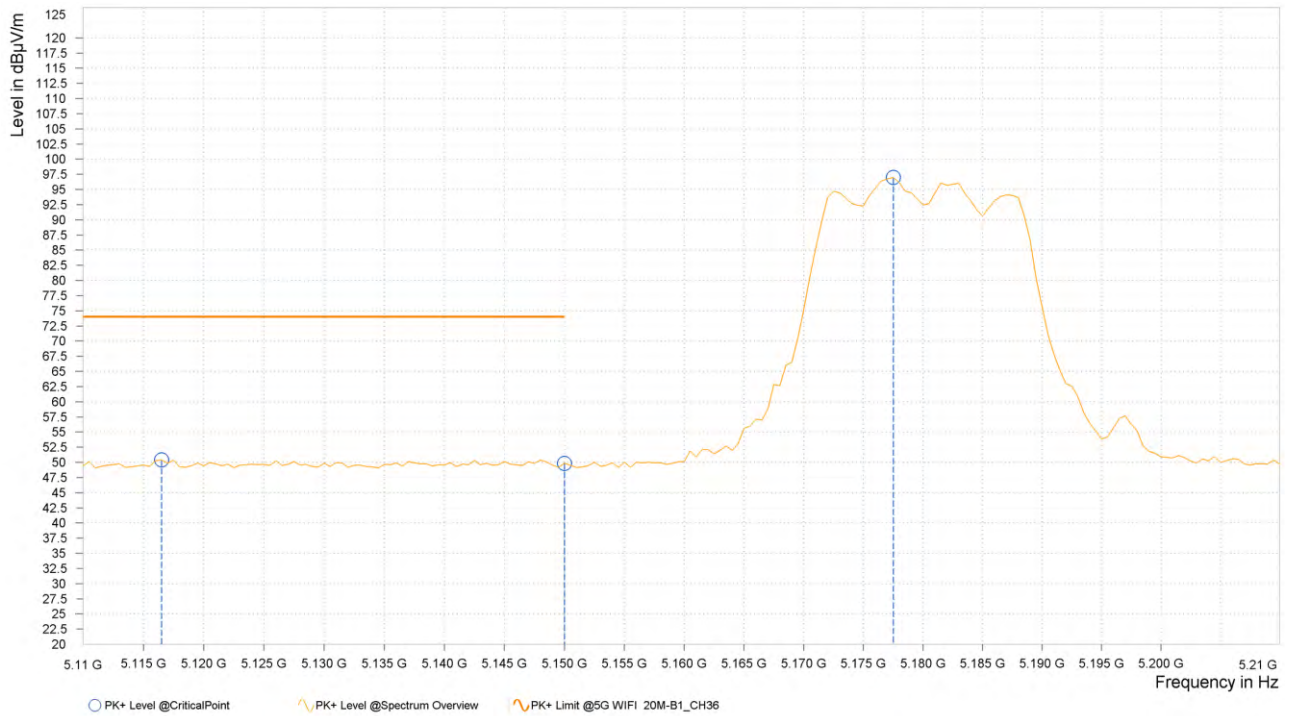



| Rg | Frequency [MHz] | AVG Level [dBμV/m] | AVG Limit [dBμV/m] | AVG Margin [dB] | Correction [dB] | Polarization | Azimuth [deg] | Antenna Height [m] |
|----|-----------------|--------------------|--------------------|-----------------|-----------------|--------------|---------------|--------------------|
| 1 | 5,146.500 | 35.63 | 54.00 | 18.37 | 10.76 | V | 1 | 1.00 |
| 1 | 5,150.000 | 35.57 | 54.00 | 18.43 | 10.77 | V | 233.6 | 1.00 |
| 1 | 5,182.500 | 82.22 | | | 10.87 | V | 233.6 | 1.00 |

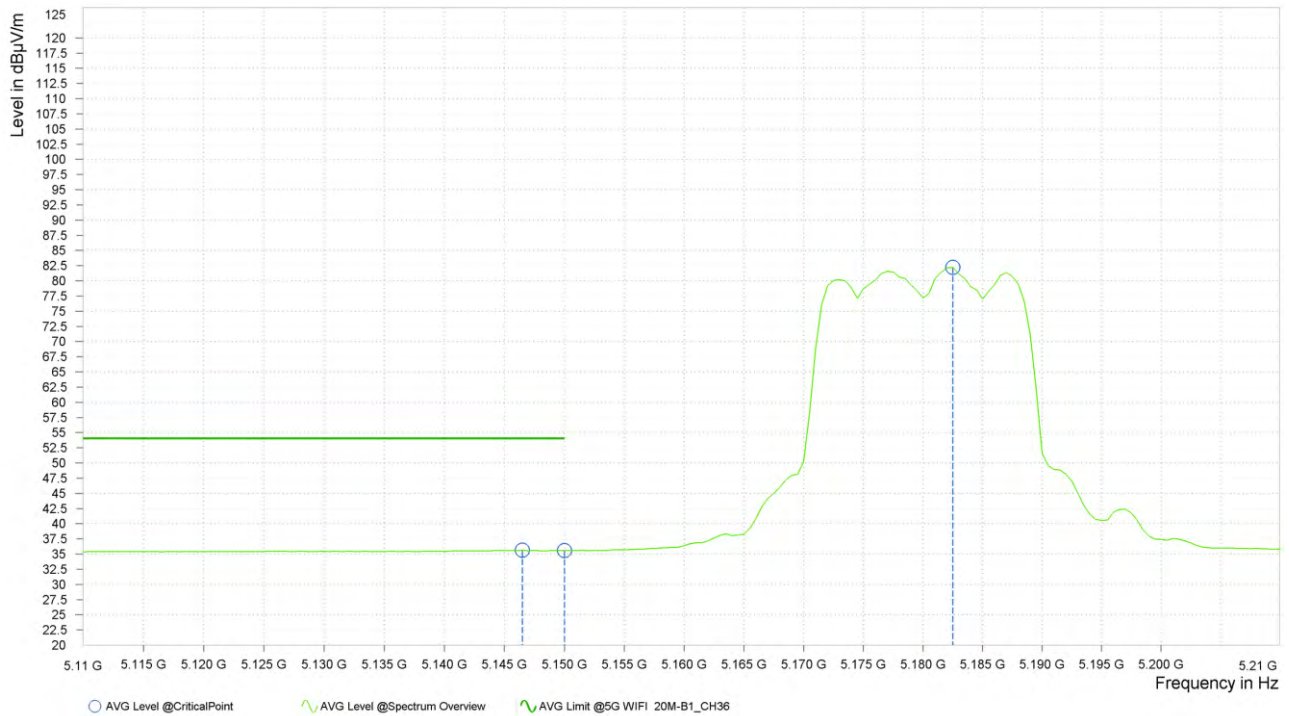

REMARKS:

1. Emission Level = Read Level+ Antenna Factor + Cable Loss- Preamp Factor
Margin value = Limit value- Emission level.
2. 5180MHz: Fundamental frequency.



**BUREAU
VERITAS**

Test Report No.: PSU-NQN2403180115RF03

| | | | |
|------------------------|---------------|--------------------------|--------------|
| CHANNEL | TX Channel 40 | DETECTOR FUNCTION | Peak (PK) |
| FREQUENCY RANGE | 1GHz ~ 40GHz | | Average (AV) |

ANTENNA POLARITY & TEST DISTANCE: HORIZONTAL AT 3 M

| Rg | Frequency [MHz] | PK+ Level [dBμV/m] | PK+ Limit [dBμV/m] | PK+ Margin [dB] | Correction [dB] | Polarization | Azimuth [deg] | Antenna Height [m] |
|----|-----------------|--------------------|--------------------|-----------------|-----------------|--------------|---------------|--------------------|
| 2 | 5,138.000 | 50.45 | 74.00 | 23.55 | 10.75 | H | 82.2 | 2.00 |
| 2 | 5,150.000 | 49.74 | 74.00 | 24.26 | 10.77 | H | 184.6 | 1.00 |
| 2 | 5,197.000 | 94.90 | | | 10.92 | H | 176.6 | 2.00 |

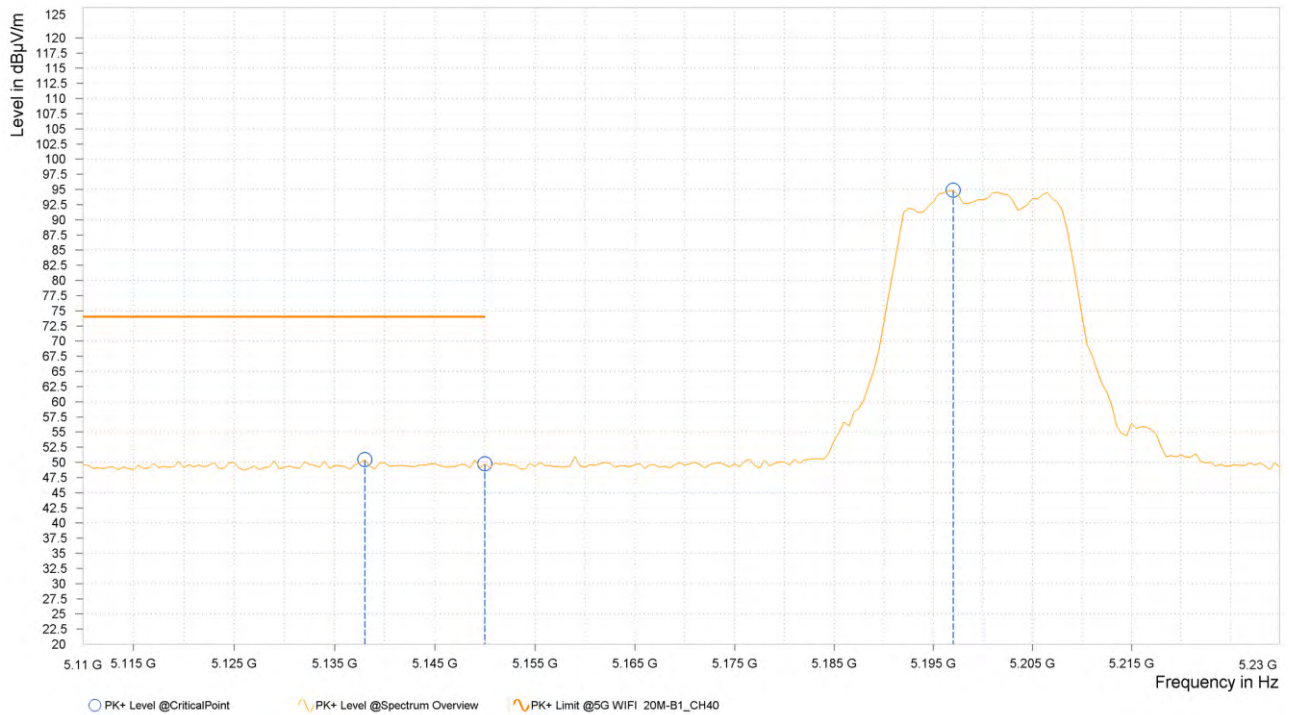



| Rg | Frequency [MHz] | AVG Level [dBμV/m] | AVG Limit [dBμV/m] | AVG Margin [dB] | Correction [dB] | Polarization | Azimuth [deg] | Antenna Height [m] |
|----|-----------------|--------------------|--------------------|-----------------|-----------------|--------------|---------------|--------------------|
| 2 | 5,132.000 | 35.45 | 54.00 | 18.55 | 10.74 | H | 176.6 | 2.00 |
| 2 | 5,150.000 | 35.55 | 54.00 | 18.45 | 10.77 | H | 176.6 | 2.00 |
| 2 | 5,201.500 | 81.03 | | | 10.93 | H | 355.4 | 1.00 |





ANTENNA POLARITY & TEST DISTANCE: VERTICAL AT 3 M

| Rg | Frequency [MHz] | PK+ Level [dBμV/m] | PK+ Limit [dBμV/m] | PK+ Margin [dB] | Correction [dB] | Polarization | Azimuth [deg] | Antenna Height [m] |
|----|-----------------|--------------------|--------------------|-----------------|-----------------|--------------|---------------|--------------------|
| 2 | 5,114.500 | 50.40 | 74.00 | 23.60 | 10.72 | V | 35.6 | 2.00 |
| 2 | 5,150.000 | 49.41 | 74.00 | 24.59 | 10.77 | V | 136.7 | 1.00 |
| 2 | 5,197.000 | 97.96 | | | 10.92 | V | 317.7 | 2.00 |





| Rg | Frequency [MHz] | AVG Level [dBμV/m] | AVG Limit [dBμV/m] | AVG Margin [dB] | Correction [dB] | Polarization | Azimuth [deg] | Antenna Height [m] |
|----|-----------------|--------------------|--------------------|-----------------|-----------------|--------------|---------------|--------------------|
| 2 | 5,123.000 | 35.45 | 54.00 | 18.55 | 10.73 | V | 185.7 | 1.00 |
| 2 | 5,150.000 | 35.49 | 54.00 | 18.51 | 10.77 | V | 1 | 1.00 |
| 2 | 5,197.000 | 83.44 | | | 10.92 | V | 316.5 | 2.00 |

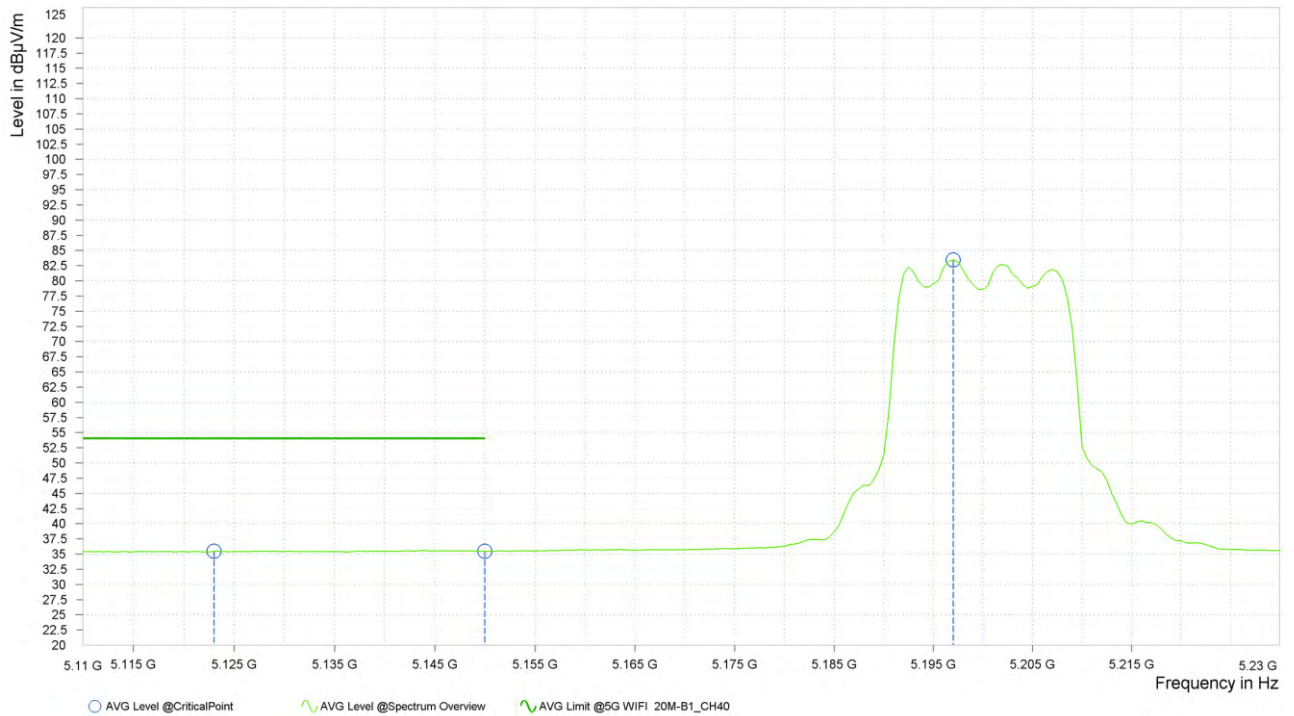

REMARKS:

1. Emission Level = Read Level+ Antenna Factor + Cable Loss- Preamp Factor
Margin value = Limit value- Emission level.
2. 5200MHz: Fundamental frequency.



**BUREAU
VERITAS**

Test Report No.: PSU-NQN2403180115RF03

| | | | |
|------------------------|---------------|--------------------------|--------------|
| CHANNEL | TX Channel 48 | DETECTOR FUNCTION | Peak (PK) |
| FREQUENCY RANGE | 1GHz ~ 40GHz | | Average (AV) |

ANTENNA POLARITY & TEST DISTANCE: HORIZONTAL AT 3 M

| Rg | Frequency [MHz] | PK+ Level [dBμV/m] | PK+ Limit [dBμV/m] | PK+ Margin [dB] | Correction [dB] | Polarization | Azimuth [deg] | Antenna Height [m] |
|----|-----------------|--------------------|--------------------|-----------------|-----------------|--------------|---------------|--------------------|
| 3 | 5,147.500 | 50.60 | 74.00 | 23.40 | 10.76 | H | 269.8 | 2.00 |
| 3 | 5,150.000 | 50.90 | 74.00 | 23.10 | 10.77 | H | 224.4 | 2.00 |
| 3 | 5,242.000 | 96.94 | | | 10.90 | H | 90.1 | 1.00 |

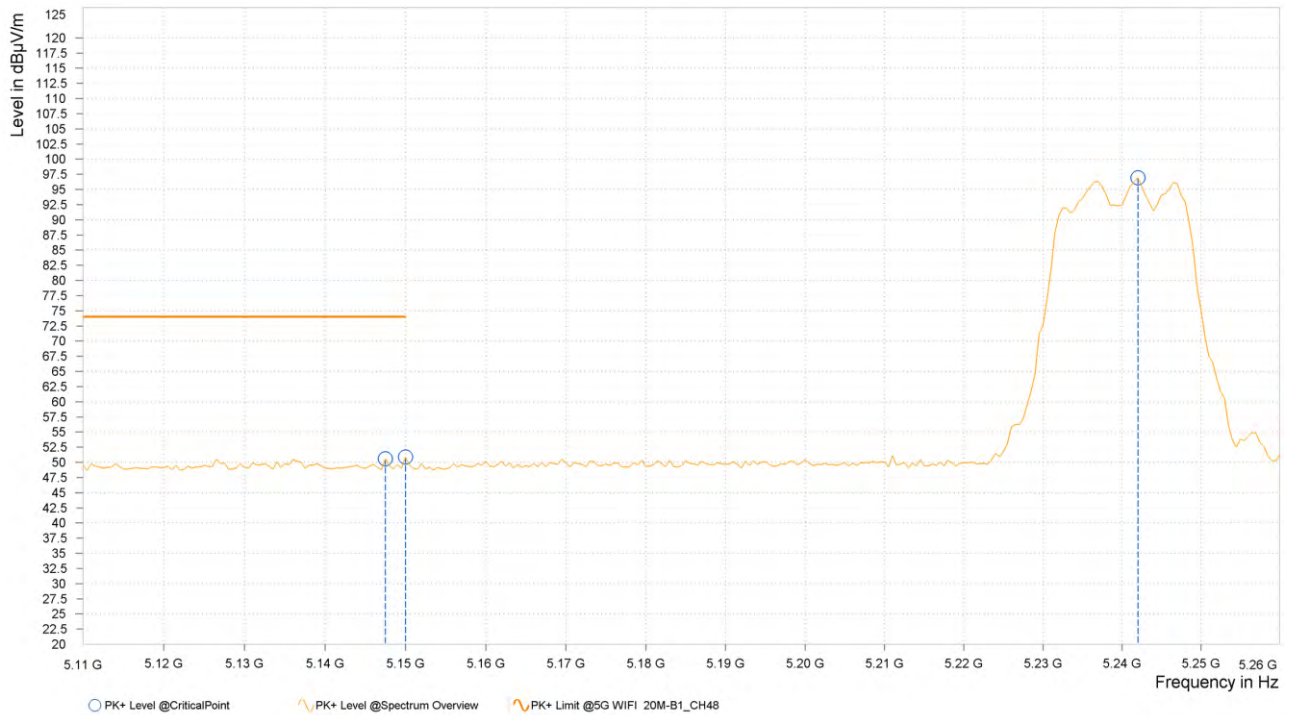

BV 7Layers Communications Technology
(Shenzhen) Co., Ltd

Room B37, Warehouse A5, No.3 Chiwan 4th Road,
Zhaoshang Street, Nanshan District Shenzhen,
Guangdong, People's Republic of China

Tel: +86 755 8869 6566
Fax: +86 755 8869 6577
Email: customerservice.sw@bureauveritas.com



| Rg | Frequency [MHz] | AVG Level [dBμV/m] | AVG Limit [dBμV/m] | AVG Margin [dB] | Correction [dB] | Polarization | Azimuth [deg] | Antenna Height [m] |
|----|-----------------|--------------------|--------------------|-----------------|-----------------|--------------|---------------|--------------------|
| 3 | 5,145.500 | 35.61 | 54.00 | 18.39 | 10.76 | H | 3 | 2.00 |
| 3 | 5,150.000 | 35.51 | 54.00 | 18.49 | 10.77 | H | 140.3 | 1.00 |
| 3 | 5,242.000 | 81.85 | | | 10.90 | H | 92.6 | 1.00 |





ANTENNA POLARITY & TEST DISTANCE: VERTICAL AT 3 M

| Rg | Frequency [MHz] | PK+ Level [dBμV/m] | PK+ Limit [dBμV/m] | PK+ Margin [dB] | Correction [dB] | Polarization | Azimuth [deg] | Antenna Height [m] |
|----|-----------------|--------------------|--------------------|-----------------|-----------------|--------------|---------------|--------------------|
| 3 | 5,139.500 | 50.73 | 74.00 | 23.27 | 10.75 | V | 1 | 1.00 |
| 3 | 5,150.000 | 49.13 | 74.00 | 24.87 | 10.77 | V | 98.6 | 1.00 |
| 3 | 5,237.000 | 97.03 | | | 10.91 | V | 175.4 | 2.00 |

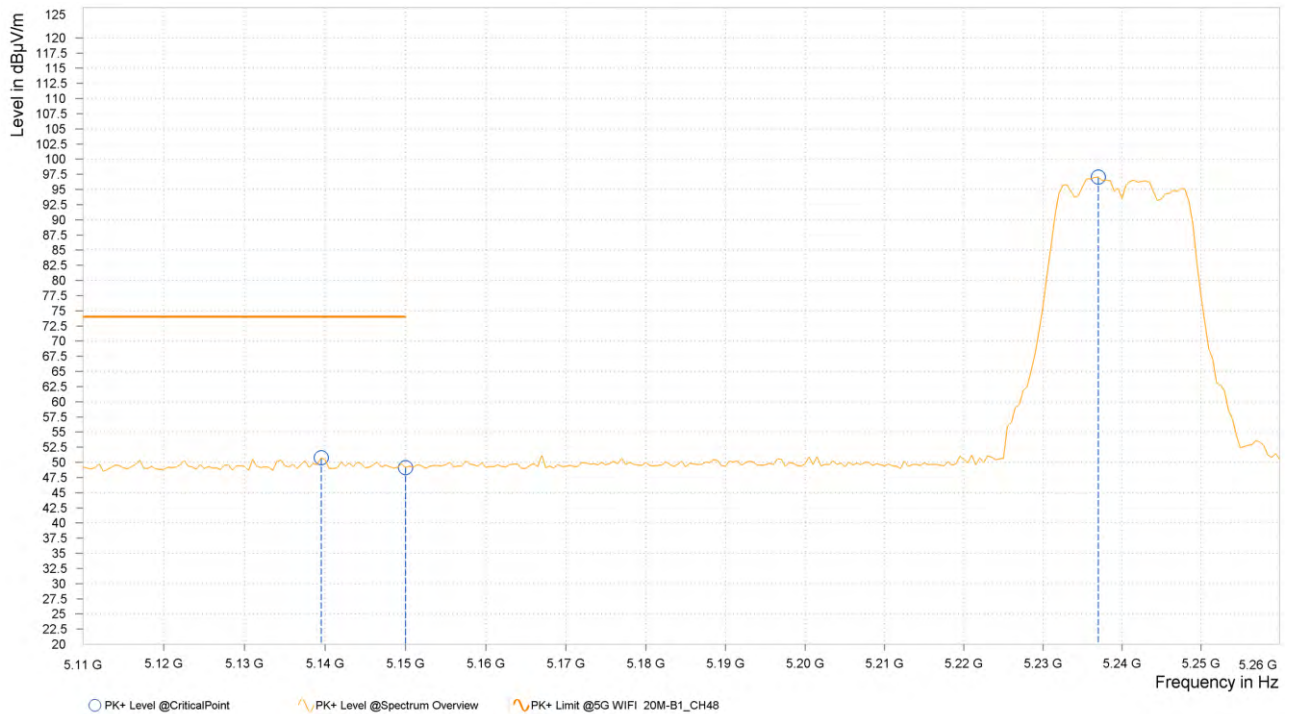



| Rg | Frequency [MHz] | AVG Level [dBμV/m] | AVG Limit [dBμV/m] | AVG Margin [dB] | Correction [dB] | Polarization | Azimuth [deg] | Antenna Height [m] |
|----|-----------------|--------------------|--------------------|-----------------|-----------------|--------------|---------------|--------------------|
| 3 | 5,145.000 | 35.55 | 54.00 | 18.45 | 10.76 | V | 357.8 | 1.00 |
| 3 | 5,150.000 | 35.46 | 54.00 | 18.54 | 10.77 | V | 359 | 1.00 |
| 3 | 5,243.000 | 83.22 | | | 10.90 | V | 42.4 | 1.00 |

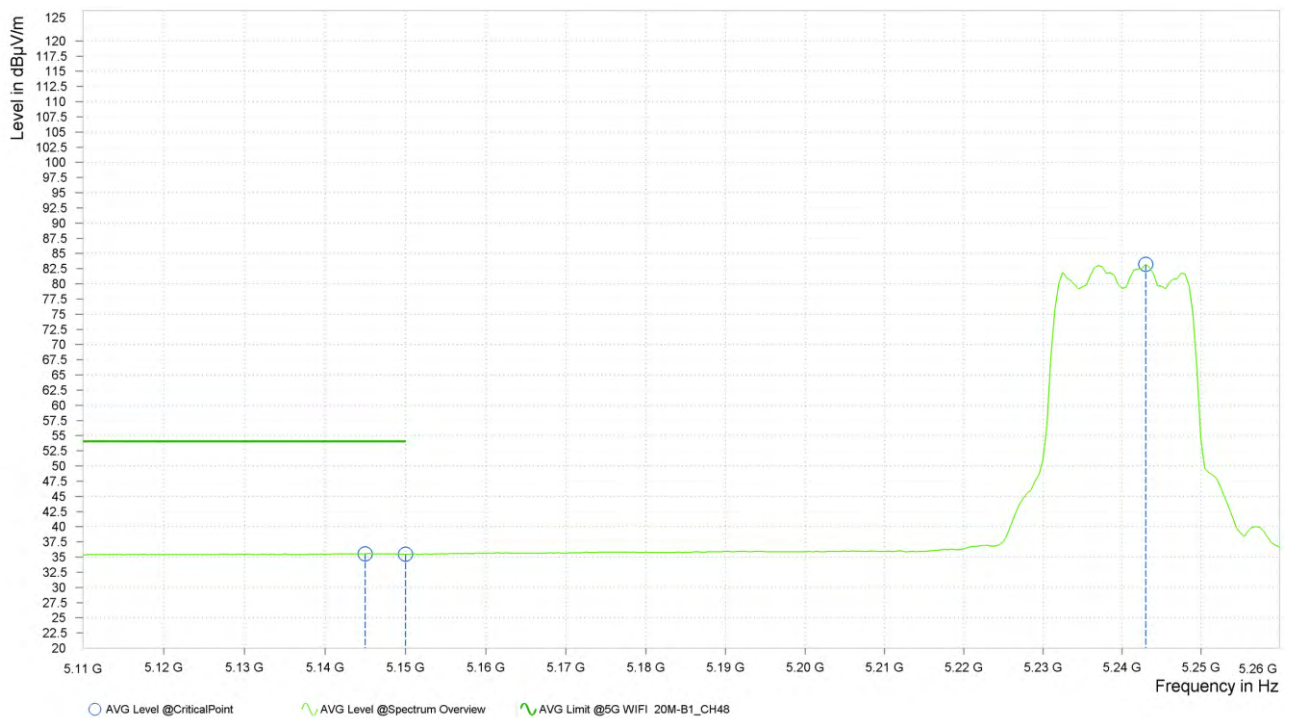

REMARKS:

1. Emission Level = Read Level+ Antenna Factor + Cable Loss- Preamp Factor
Margin value = Limit value- Emission level.
2. 5240MHz: Fundamental frequency.



**BUREAU
VERITAS**

Test Report No.: PSU-NQN2403180115RF03

802.11n (20MHz)

| | | | |
|------------------------|---------------|--------------------------|--------------|
| CHANNEL | TX Channel 36 | DETECTOR FUNCTION | Peak (PK) |
| FREQUENCY RANGE | 1GHz ~ 40GHz | | Average (AV) |

ANTENNA POLARITY & TEST DISTANCE: HORIZONTAL AT 3 M

| Rg | Frequency [MHz] | PK+ Level [dBμV/m] | PK+ Limit [dBμV/m] | PK+ Margin [dB] | Correction [dB] | Polarization | Azimuth [deg] | Antenna Height [m] |
|----|-----------------|--------------------|--------------------|-----------------|-----------------|--------------|---------------|--------------------|
| 1 | 5,142.500 | 50.87 | 74.00 | 23.13 | 10.76 | H | 102.2 | 1.00 |
| 1 | 5,150.000 | 49.33 | 74.00 | 24.67 | 10.77 | H | 1 | 1.00 |
| 1 | 5,182.500 | 94.57 | | | 10.87 | H | 359 | 2.00 |

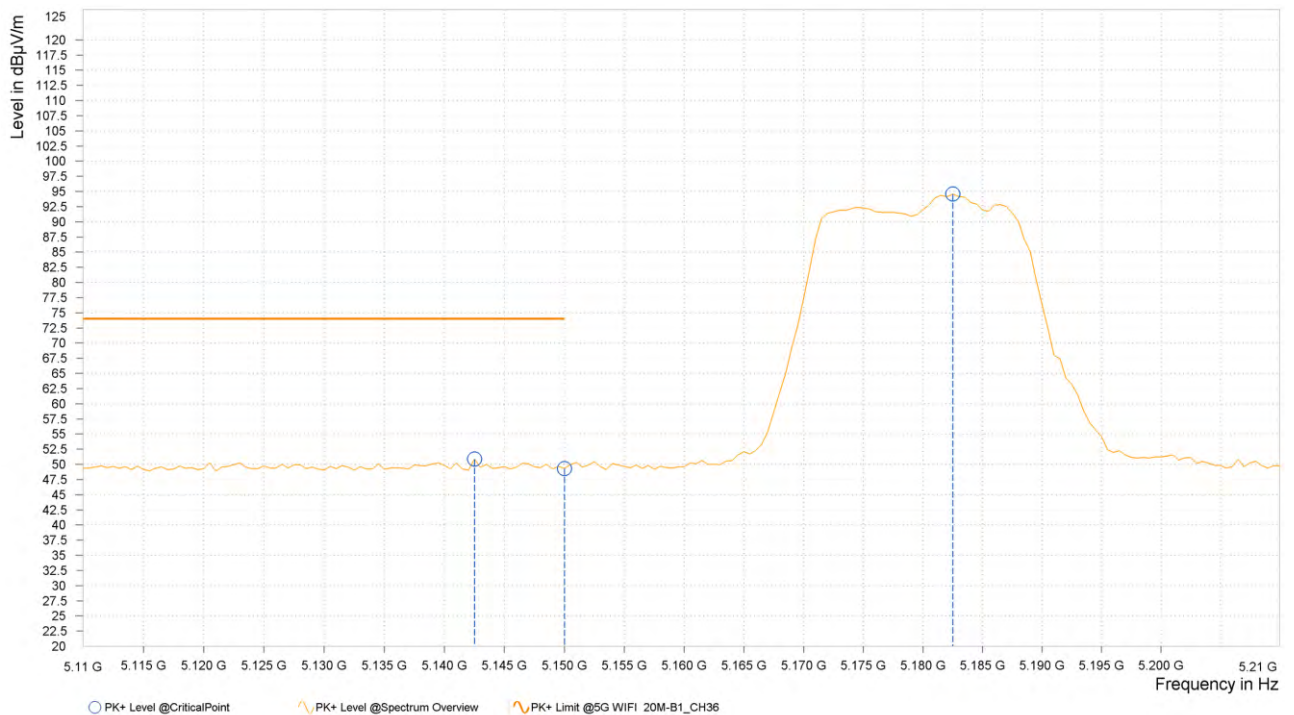



| Rg | Frequency [MHz] | AVG Level [dBμV/m] | AVG Limit [dBμV/m] | AVG Margin [dB] | Correction [dB] | Polarization | Azimuth [deg] | Antenna Height [m] |
|----|-----------------|--------------------|--------------------|-----------------|-----------------|--------------|---------------|--------------------|
| 1 | 5,140.500 | 35.60 | 54.00 | 18.40 | 10.75 | H | 153.8 | 2.00 |
| 1 | 5,150.000 | 35.61 | 54.00 | 18.39 | 10.77 | H | 153.8 | 2.00 |
| 1 | 5,182.500 | 79.42 | | | 10.87 | H | 359 | 2.00 |

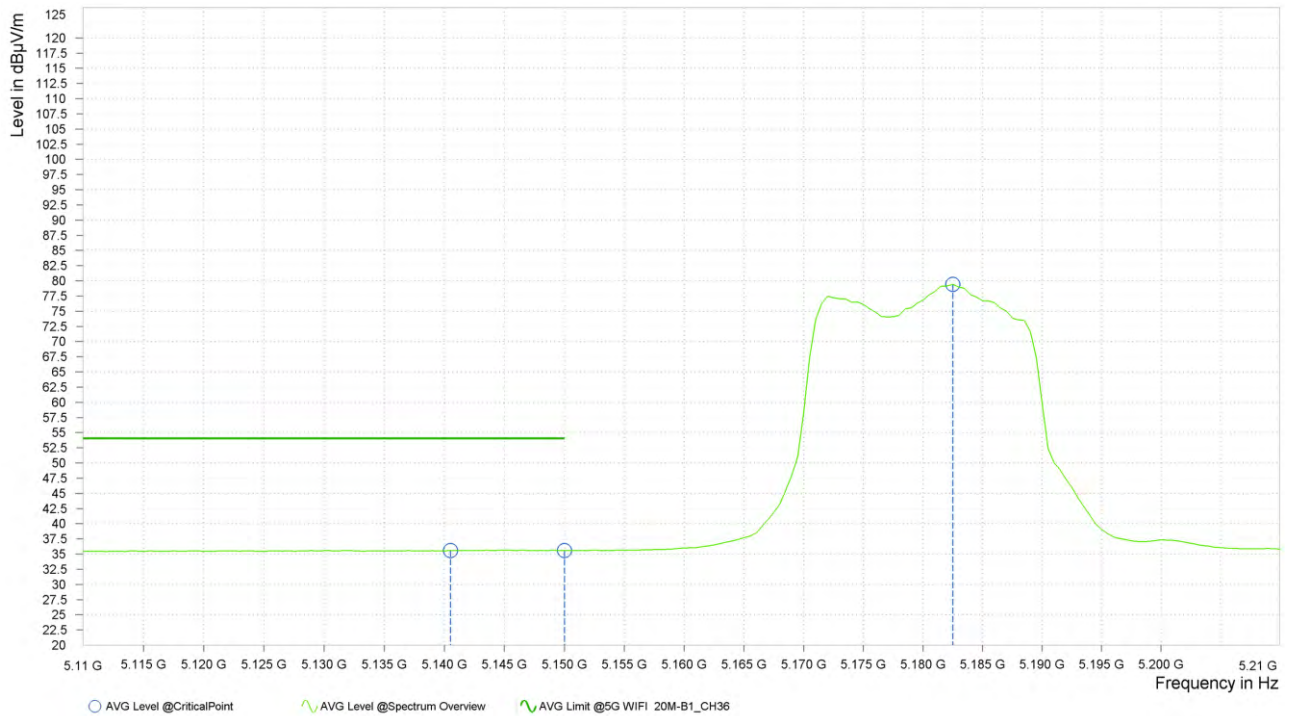



ANTENNA POLARITY & TEST DISTANCE: VERTICAL AT 3 M

| Rg | Frequency [MHz] | PK+ Level [dBμV/m] | PK+ Limit [dBμV/m] | PK+ Margin [dB] | Correction [dB] | Polarization | Azimuth [deg] | Antenna Height [m] |
|----|-----------------|--------------------|--------------------|-----------------|-----------------|--------------|---------------|--------------------|
| 1 | 5,128.000 | 50.53 | 74.00 | 23.47 | 10.74 | V | 351.2 | 1.00 |
| 1 | 5,150.000 | 49.80 | 74.00 | 24.20 | 10.77 | V | 359 | 1.00 |
| 1 | 5,184.000 | 98.54 | | | 10.88 | V | 314.1 | 2.00 |

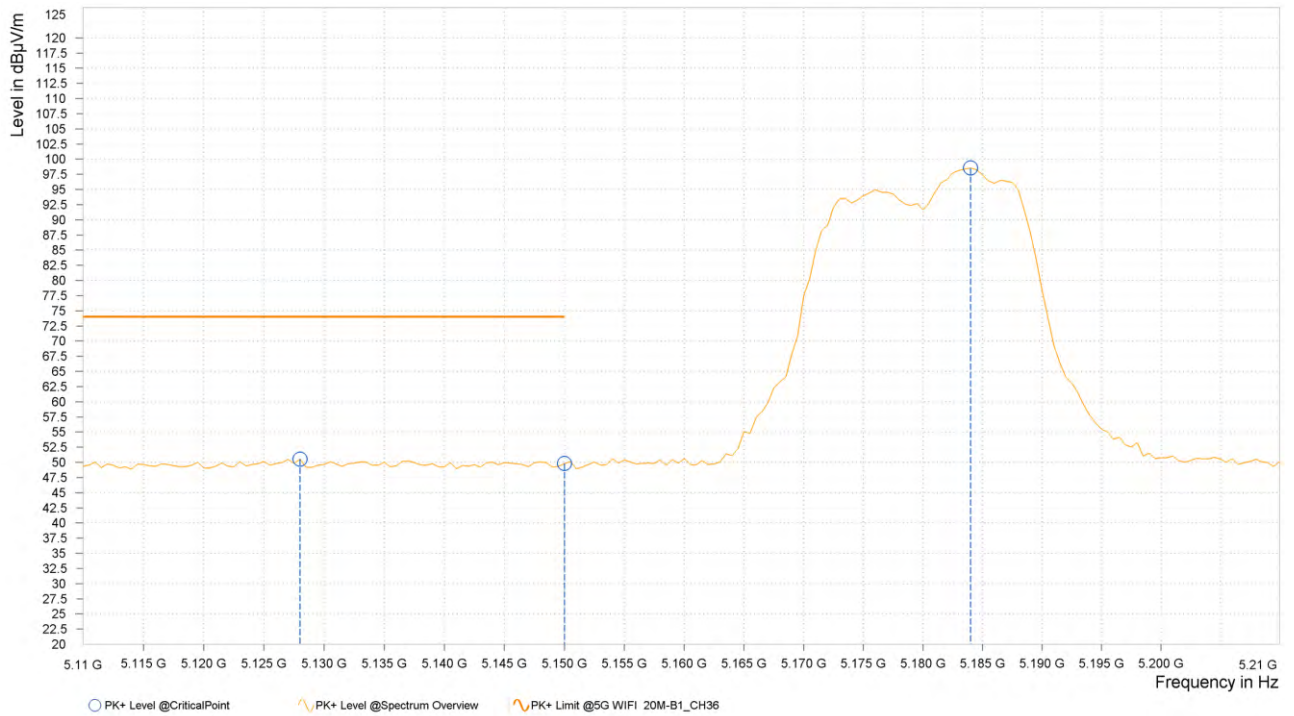



| Rg | Frequency [MHz] | AVG Level [dBμV/m] | AVG Limit [dBμV/m] | AVG Margin [dB] | Correction [dB] | Polarization | Azimuth [deg] | Antenna Height [m] |
|----|-----------------|--------------------|--------------------|-----------------|-----------------|--------------|---------------|--------------------|
| 1 | 5,146.500 | 35.68 | 54.00 | 18.32 | 10.76 | V | 155.1 | 2.00 |
| 1 | 5,150.000 | 35.59 | 54.00 | 18.41 | 10.77 | V | 257.5 | 1.00 |
| 1 | 5,183.000 | 82.45 | | | 10.87 | V | 311.7 | 2.00 |



REMARKS:

1. Emission Level = Read Level+ Antenna Factor + Cable Loss- Preamp Factor
Margin value = Limit value- Emission level.
2. 5180MHz: Fundamental frequency.



**BUREAU
VERITAS**

Test Report No.: PSU-NQN2403180115RF03

| | | | |
|------------------------|---------------|--------------------------|--------------|
| CHANNEL | TX Channel 40 | DETECTOR FUNCTION | Peak (PK) |
| FREQUENCY RANGE | 1GHz ~ 40GHz | | Average (AV) |

ANTENNA POLARITY & TEST DISTANCE: HORIZONTAL AT 3 M

| Rg | Frequency [MHz] | PK+ Level [dBμV/m] | PK+ Limit [dBμV/m] | PK+ Margin [dB] | Correction [dB] | Polarization | Azimuth [deg] | Antenna Height [m] |
|----|-----------------|--------------------|--------------------|-----------------|-----------------|--------------|---------------|--------------------|
| 2 | 5,137.000 | 50.82 | 74.00 | 23.18 | 10.75 | H | 205.4 | 2.00 |
| 2 | 5,150.000 | 49.35 | 74.00 | 24.65 | 10.77 | H | 102.2 | 1.00 |
| 2 | 5,201.500 | 94.45 | | | 10.93 | H | 313.7 | 1.00 |

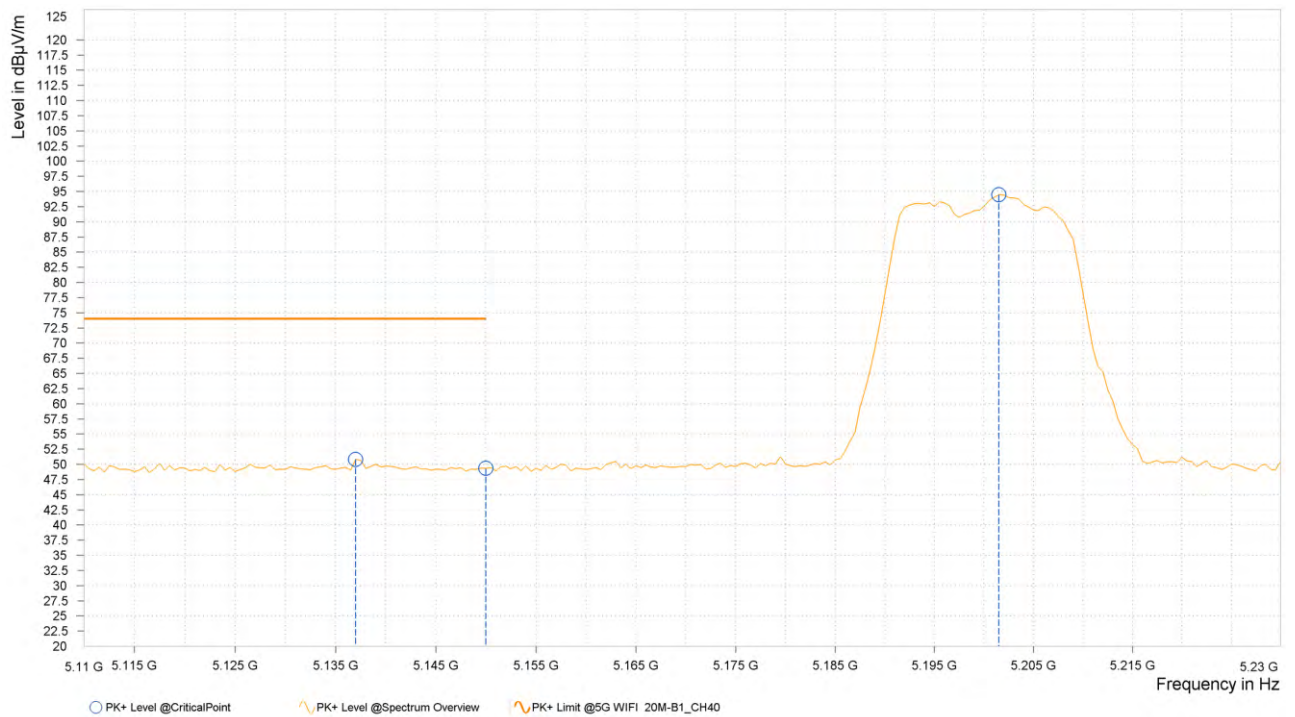



| Rg | Frequency [MHz] | AVG Level [dBμV/m] | AVG Limit [dBμV/m] | AVG Margin [dB] | Correction [dB] | Polarization | Azimuth [deg] | Antenna Height [m] |
|----|-----------------|--------------------|--------------------|-----------------|-----------------|--------------|---------------|--------------------|
| 2 | 5,142.500 | 35.59 | 54.00 | 18.41 | 10.76 | H | 207.7 | 2.00 |
| 2 | 5,150.000 | 35.54 | 54.00 | 18.46 | 10.77 | H | 6.2 | 2.00 |
| 2 | 5,202.500 | 79.02 | | | 10.93 | H | 359 | 2.00 |





ANTENNA POLARITY & TEST DISTANCE: VERTICAL AT 3 M

| Rg | Frequency [MHz] | PK+ Level [dBμV/m] | PK+ Limit [dBμV/m] | PK+ Margin [dB] | Correction [dB] | Polarization | Azimuth [deg] | Antenna Height [m] |
|----|-----------------|--------------------|--------------------|-----------------|-----------------|--------------|---------------|--------------------|
| 2 | 5,140.500 | 50.66 | 74.00 | 23.34 | 10.75 | V | 1 | 1.00 |
| 2 | 5,150.000 | 49.29 | 74.00 | 24.71 | 10.77 | V | 359.1 | 1.00 |
| 2 | 5,204.000 | 95.02 | | | 10.93 | V | 207.3 | 1.00 |





| Rg | Frequency [MHz] | AVG Level [dBμV/m] | AVG Limit [dBμV/m] | AVG Margin [dB] | Correction [dB] | Polarization | Azimuth [deg] | Antenna Height [m] |
|----|-----------------|--------------------|--------------------|-----------------|-----------------|--------------|---------------|--------------------|
| 2 | 5,144.000 | 35.64 | 54.00 | 18.36 | 10.76 | V | 149.2 | 2.00 |
| 2 | 5,150.000 | 35.63 | 54.00 | 18.37 | 10.77 | V | 309.3 | 2.00 |
| 2 | 5,203.500 | 80.72 | | | 10.93 | V | 209.7 | 1.00 |



REMARKS:

- Emission Level = Read Level+ Antenna Factor + Cable Loss- Preamp Factor
Margin value = Limit value- Emission level.
- 5200MHz: Fundamental frequency.



**BUREAU
VERITAS**

Test Report No.: PSU-NQN2403180115RF03

| | | | |
|------------------------|---------------|--------------------------|--------------|
| CHANNEL | TX Channel 48 | DETECTOR FUNCTION | Peak (PK) |
| FREQUENCY RANGE | 1GHz ~ 40GHz | | Average (AV) |

ANTENNA POLARITY & TEST DISTANCE: HORIZONTAL AT 3 M

| Rg | Frequency [MHz] | PK+ Level [dBμV/m] | PK+ Limit [dBμV/m] | PK+ Margin [dB] | Correction [dB] | Polarization | Azimuth [deg] | Antenna Height [m] |
|----|-----------------|--------------------|--------------------|-----------------|-----------------|--------------|---------------|--------------------|
| 3 | 5,137.000 | 50.53 | 74.00 | 23.47 | 10.75 | H | 351.7 | 1.00 |
| 3 | 5,150.000 | 49.27 | 74.00 | 24.73 | 10.77 | H | 359 | 2.00 |
| 3 | 5,242.000 | 95.04 | | | 10.90 | H | 303 | 1.00 |

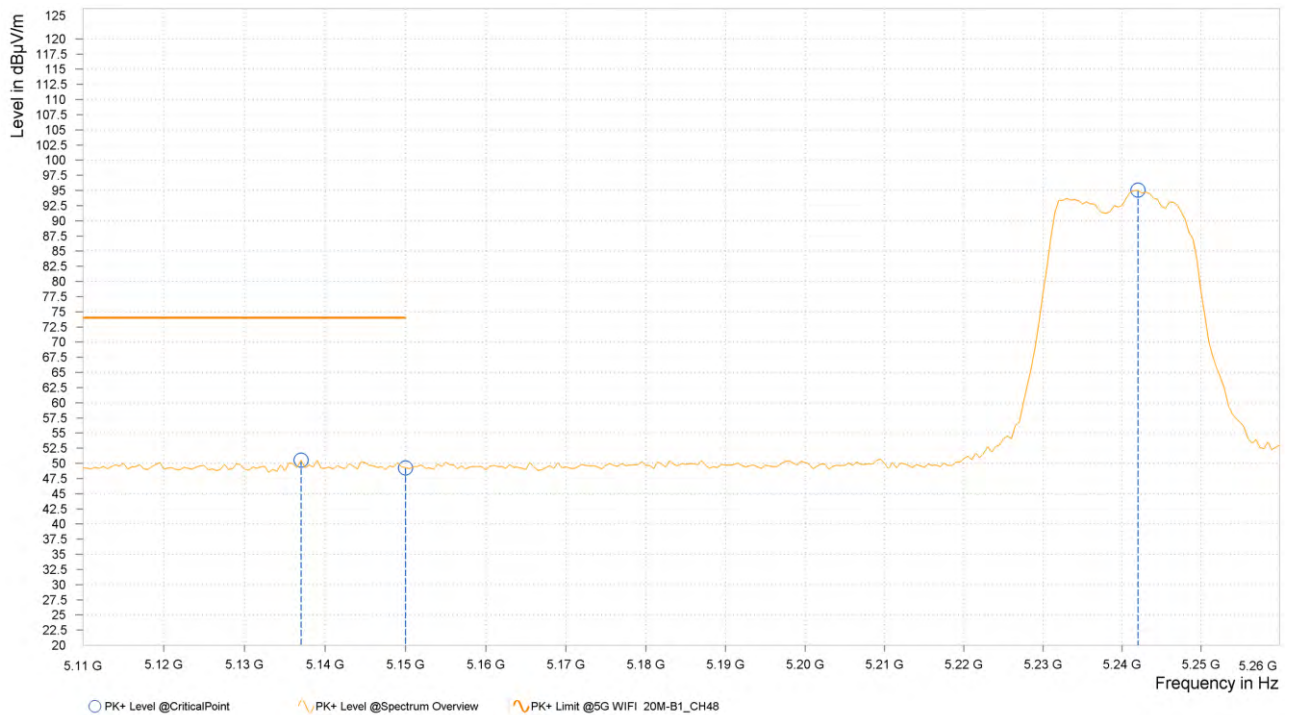



| Rg | Frequency [MHz] | AVG Level [dBμV/m] | AVG Limit [dBμV/m] | AVG Margin [dB] | Correction [dB] | Polarization | Azimuth [deg] | Antenna Height [m] |
|----|-----------------|--------------------|--------------------|-----------------|-----------------|--------------|---------------|--------------------|
| 3 | 5,144.000 | 36.18 | 54.00 | 17.82 | 10.76 | H | 1.4 | 2.00 |
| 3 | 5,150.000 | 36.09 | 54.00 | 17.91 | 10.77 | H | 359 | 2.00 |
| 3 | 5,242.500 | 83.06 | | | 10.90 | H | 359 | 2.00 |





ANTENNA POLARITY & TEST DISTANCE: VERTICAL AT 3 M

| Rg | Frequency [MHz] | PK+ Level [dBμV/m] | PK+ Limit [dBμV/m] | PK+ Margin [dB] | Correction [dB] | Polarization | Azimuth [deg] | Antenna Height [m] |
|----|-----------------|--------------------|--------------------|-----------------|-----------------|--------------|---------------|--------------------|
| 3 | 5,123.500 | 50.48 | 74.00 | 23.52 | 10.73 | V | 102.2 | 1.00 |
| 3 | 5,150.000 | 49.16 | 74.00 | 24.84 | 10.77 | V | 316.1 | 1.00 |
| 3 | 5,244.000 | 98.33 | | | 10.90 | V | 210.9 | 1.00 |

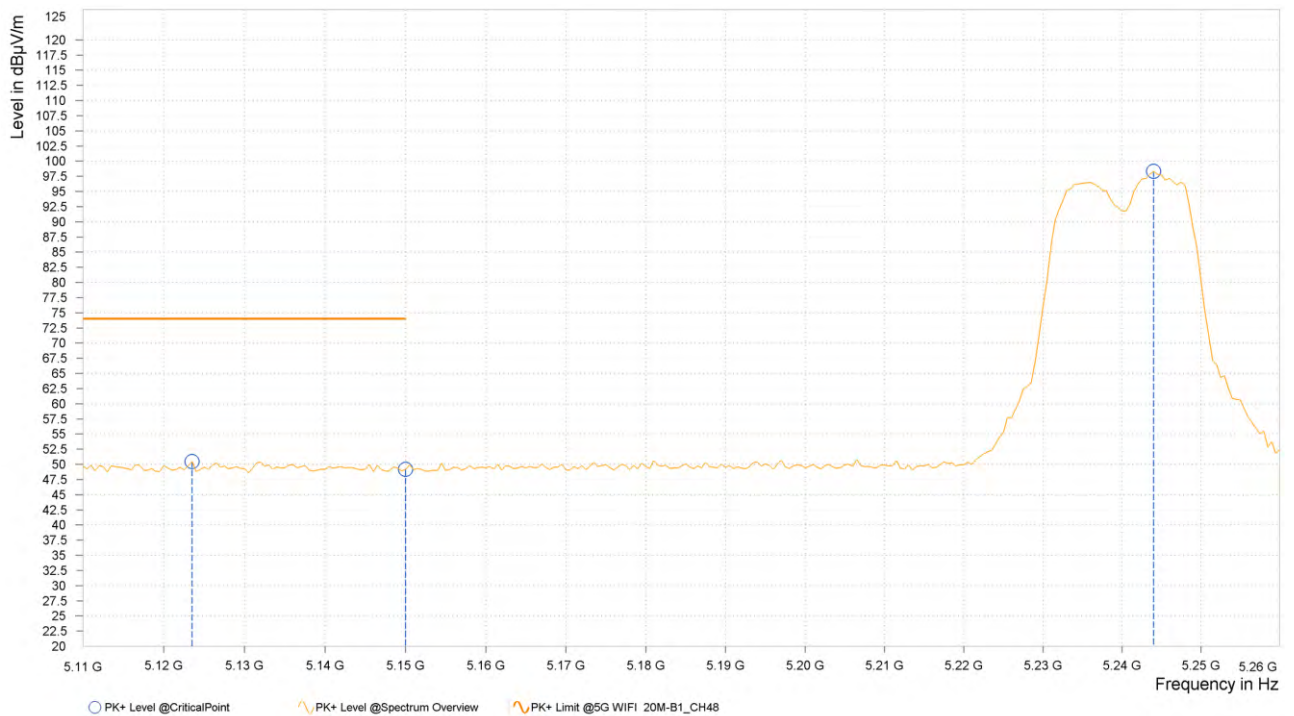



| Rg | Frequency [MHz] | AVG Level [dBμV/m] | AVG Limit [dBμV/m] | AVG Margin [dB] | Correction [dB] | Polarization | Azimuth [deg] | Antenna Height [m] |
|----|-----------------|--------------------|--------------------|-----------------|-----------------|--------------|---------------|--------------------|
| 3 | 5,117.000 | 36.11 | 54.00 | 17.89 | 10.72 | V | 1 | 1.00 |
| 3 | 5,150.000 | 36.10 | 54.00 | 17.90 | 10.77 | V | 359.1 | 1.00 |
| 3 | 5,244.500 | 86.19 | | | 10.90 | V | 209.7 | 1.00 |

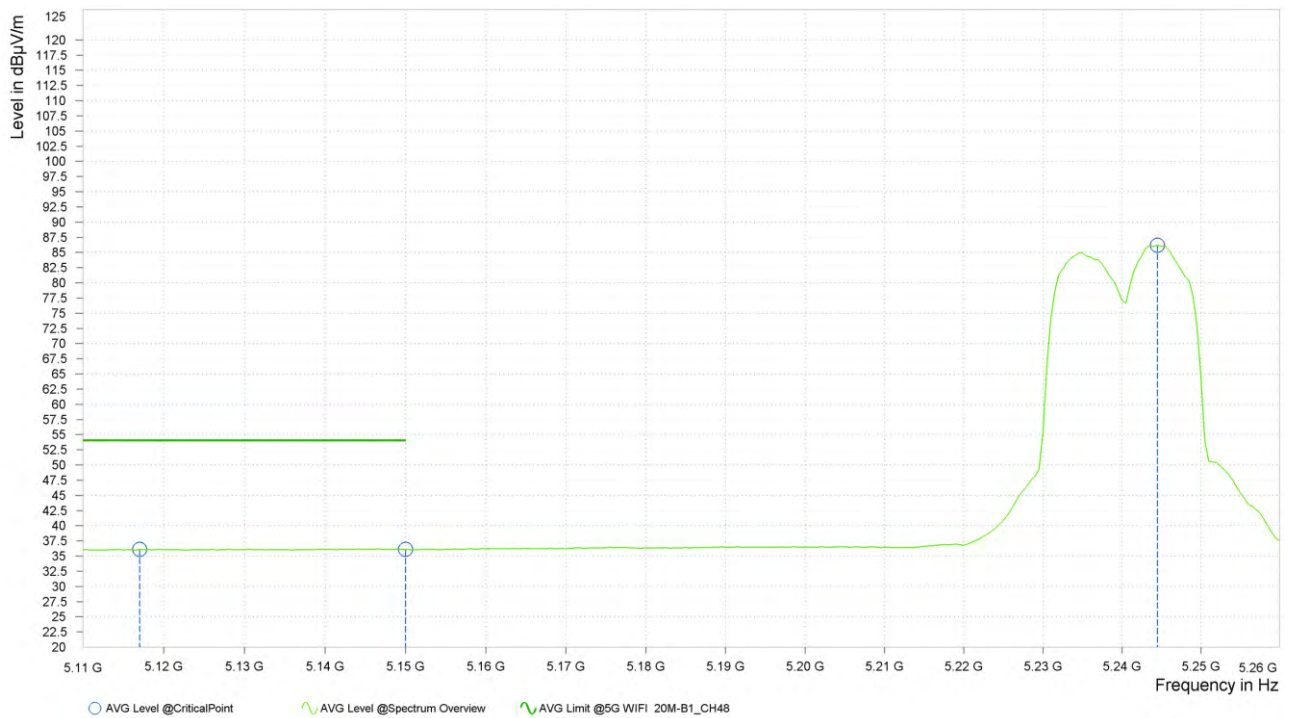

REMARKS:

1. Emission Level = Read Level+ Antenna Factor + Cable Loss- Preamp Factor
Margin value = Limit value- Emission level.
2. 5240MHz: Fundamental frequency.



802.11n (40MHz)

| | | | |
|------------------------|---------------|--------------------------|--------------|
| CHANNEL | TX Channel 38 | DETECTOR FUNCTION | Peak (PK) |
| FREQUENCY RANGE | 1GHz ~ 40GHz | | Average (AV) |

ANTENNA POLARITY & TEST DISTANCE: HORIZONTAL AT 3 M

| Rg | Frequency [MHz] | PK+ Level [dBμV/m] | PK+ Limit [dBμV/m] | PK+ Margin [dB] | Correction [dB] | Polarization | Azimuth [deg] | Antenna Height [m] |
|----|-----------------|--------------------|--------------------|-----------------|-----------------|--------------|---------------|--------------------|
| 1 | 5,131.000 | 50.74 | 74.00 | 23.26 | 10.74 | H | 357.6 | 1.00 |
| 1 | 5,150.000 | 51.08 | 74.00 | 22.92 | 10.77 | H | 359.1 | 1.00 |
| 1 | 5,192.000 | 93.46 | | | 10.90 | H | 318.5 | 1.00 |

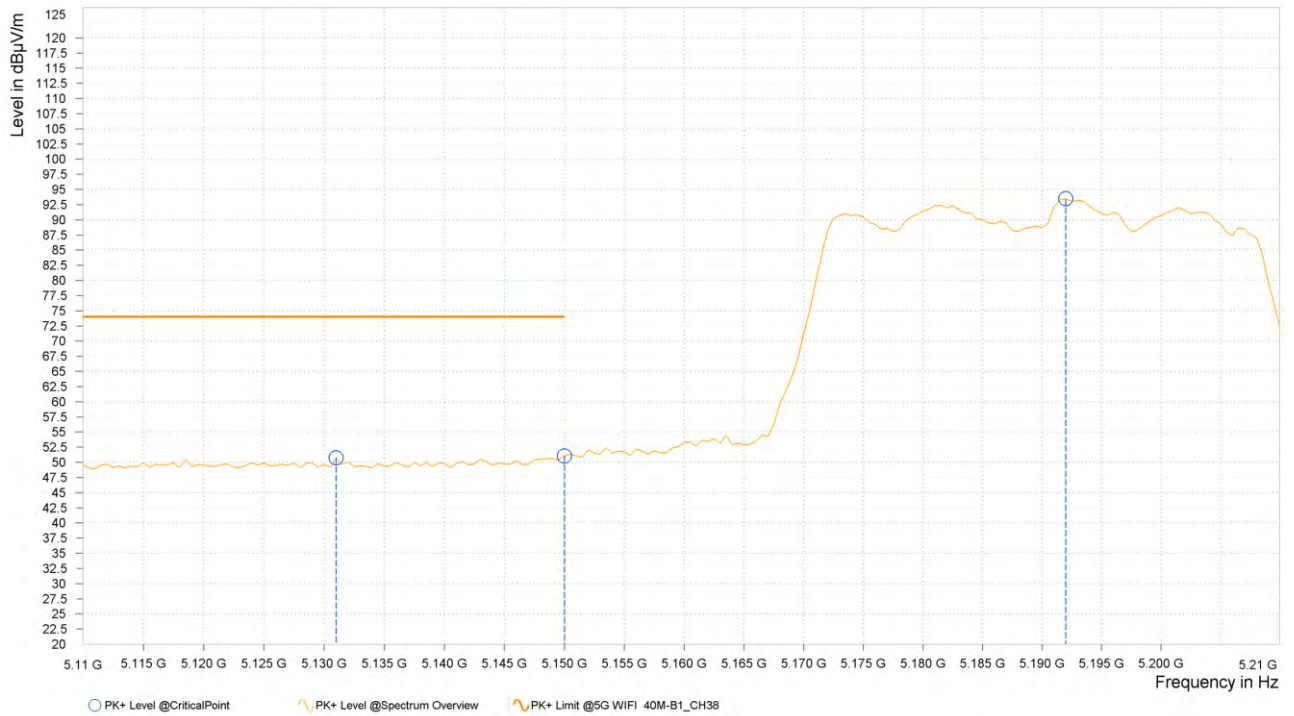



| Rg | Frequency [MHz] | AVG Level [dBμV/m] | AVG Limit [dBμV/m] | AVG Margin [dB] | Correction [dB] | Polarization | Azimuth [deg] | Antenna Height [m] |
|----|-----------------|--------------------|--------------------|-----------------|-----------------|--------------|---------------|--------------------|
| 1 | 5,148.000 | 35.91 | 54.00 | 18.09 | 10.76 | H | 1 | 2.00 |
| 1 | 5,150.000 | 36.29 | 54.00 | 17.71 | 10.77 | H | 355.8 | 2.00 |
| 1 | 5,192.000 | 79.05 | | | 10.90 | H | 322.1 | 1.00 |

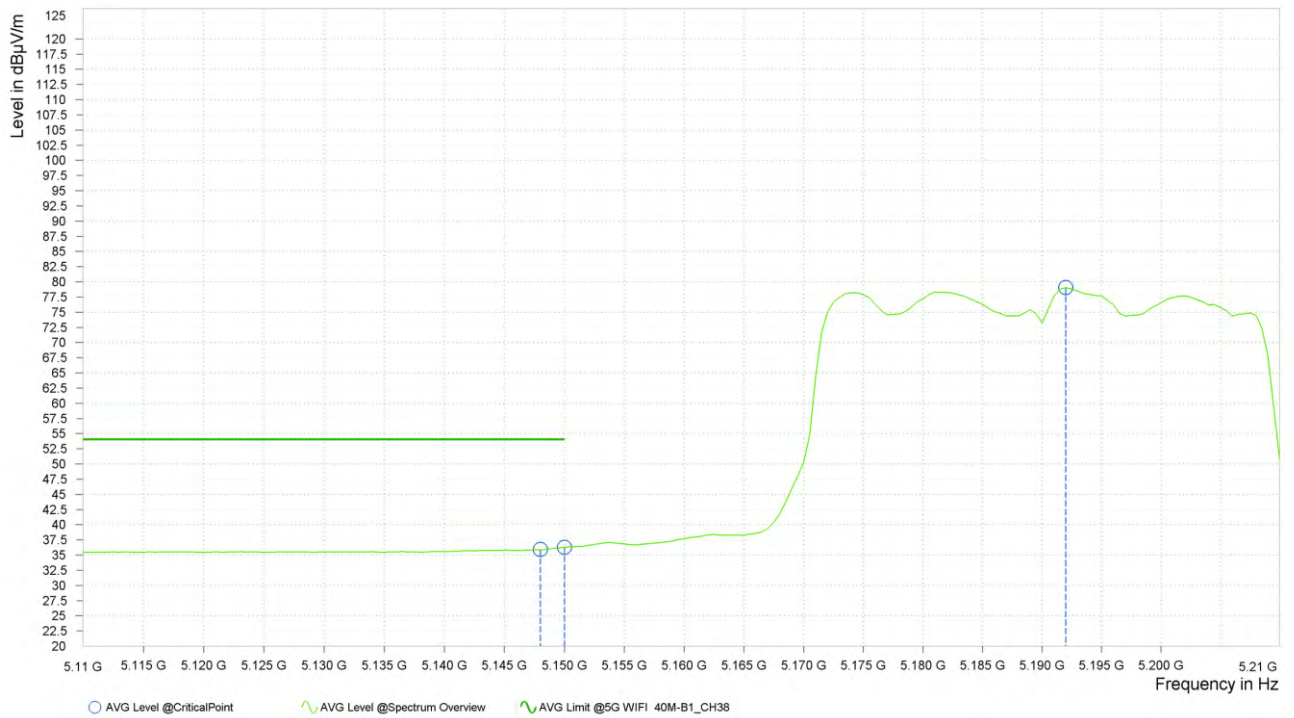



ANTENNA POLARITY & TEST DISTANCE: VERTICAL AT 3 M

| Rg | Frequency [MHz] | PK+ Level [dBμV/m] | PK+ Limit [dBμV/m] | PK+ Margin [dB] | Correction [dB] | Polarization | Azimuth [deg] | Antenna Height [m] |
|----|-----------------|--------------------|--------------------|-----------------|-----------------|--------------|---------------|--------------------|
| 1 | 5,114.500 | 50.77 | 74.00 | 23.23 | 10.72 | V | 124.9 | 1.00 |
| 1 | 5,150.000 | 49.77 | 74.00 | 24.23 | 10.77 | V | 169.4 | 2.00 |
| 1 | 5,183.000 | 94.74 | | | 10.87 | V | 169.4 | 2.00 |

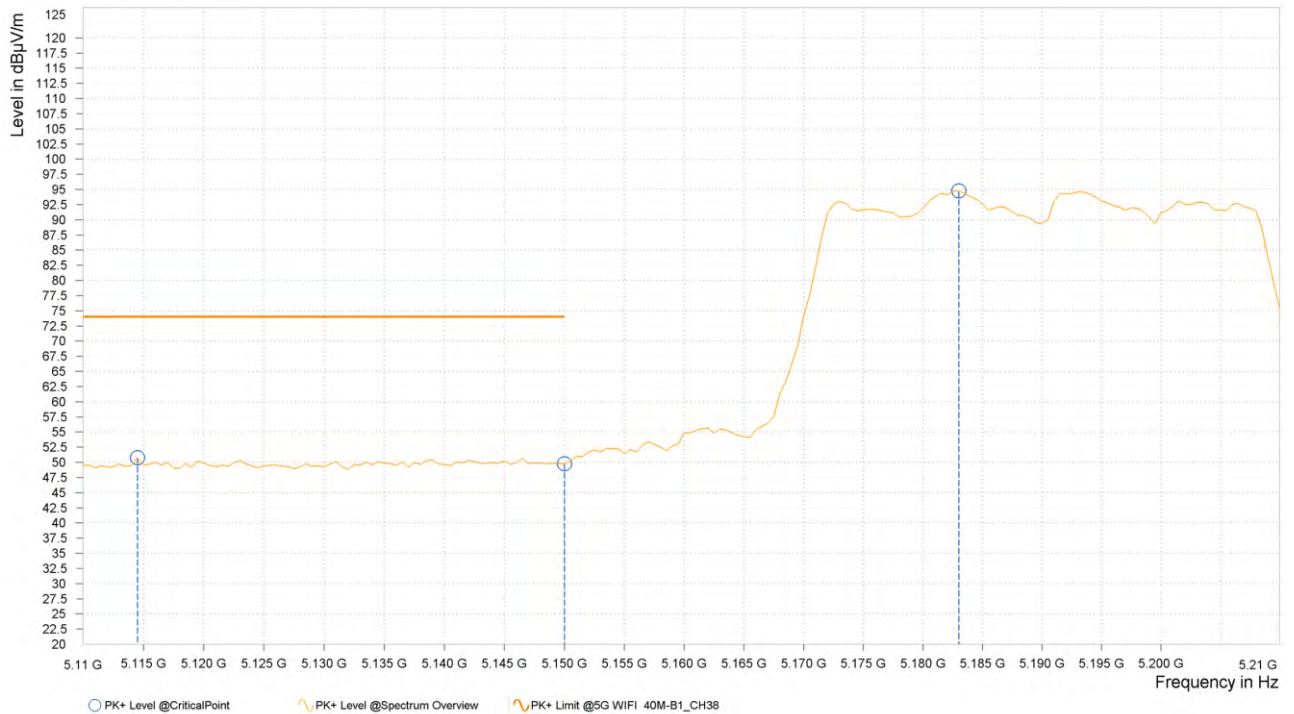



| Rg | Frequency [MHz] | AVG Level [dBμV/m] | AVG Limit [dBμV/m] | AVG Margin [dB] | Correction [dB] | Polarization | Azimuth [deg] | Antenna Height [m] |
|----|-----------------|--------------------|--------------------|-----------------|-----------------|--------------|---------------|--------------------|
| 1 | 5,145.000 | 35.94 | 54.00 | 18.06 | 10.76 | V | 232.4 | 1.00 |
| 1 | 5,150.000 | 36.33 | 54.00 | 17.67 | 10.77 | V | 169.4 | 2.00 |
| 1 | 5,184.500 | 80.87 | | | 10.88 | V | 232.4 | 1.00 |

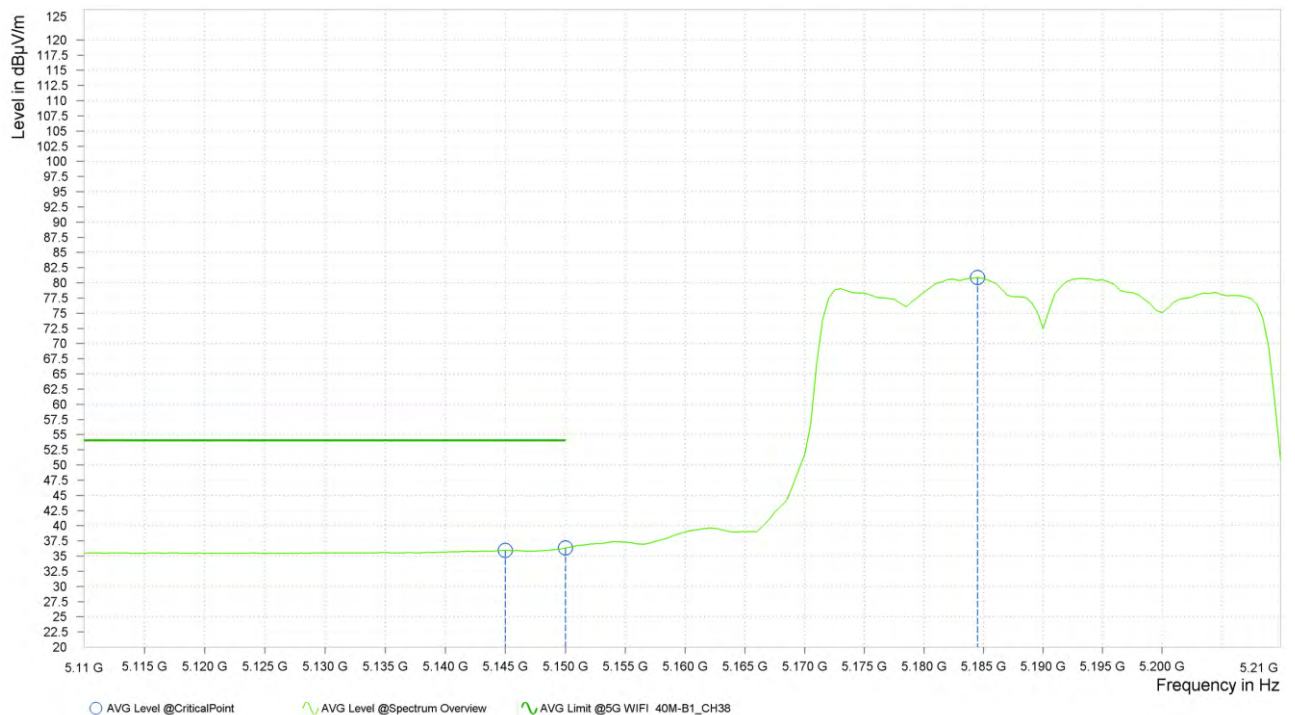

REMARKS:

1. Emission Level = Read Level+ Antenna Factor + Cable Loss- Preamp Factor
Margin value = Limit value- Emission level.
2. 5190MHz: Fundamental frequency.



| | | | |
|------------------------|---------------|--------------------------|--------------|
| CHANNEL | TX Channel 46 | DETECTOR FUNCTION | Peak (PK) |
| FREQUENCY RANGE | 1GHz ~ 40GHz | | Average (AV) |

ANTENNA POLARITY & TEST DISTANCE: HORIZONTAL AT 3 M

| Rg | Frequency [MHz] | PK+ Level [dBμV/m] | PK+ Limit [dBμV/m] | PK+ Margin [dB] | Correction [dB] | Polarization | Azimuth [deg] | Antenna Height [m] |
|----|-----------------|--------------------|--------------------|-----------------|-----------------|--------------|---------------|--------------------|
| 2 | 5,138.125 | 50.37 | 74.00 | 23.63 | 10.75 | H | 65.4 | 2.00 |
| 2 | 5,150.125 | 50.02 | 74.00 | 23.98 | 10.77 | H | 188.2 | 1.00 |
| 2 | 5,222.500 | 93.13 | | | 10.92 | H | 1 | 1.00 |

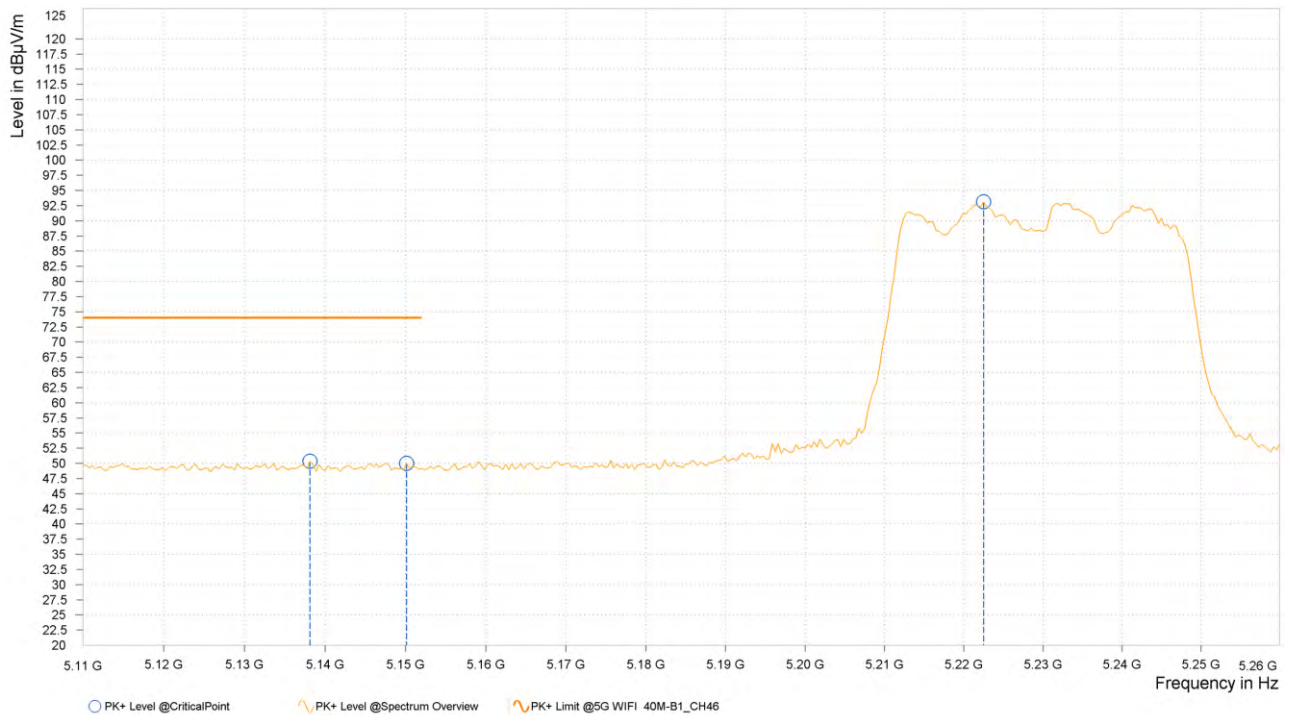



| Rg | Frequency [MHz] | AVG Level [dBμV/m] | AVG Limit [dBμV/m] | AVG Margin [dB] | Correction [dB] | Polarization | Azimuth [deg] | Antenna Height [m] |
|----|-----------------|--------------------|--------------------|-----------------|-----------------|--------------|---------------|--------------------|
| 2 | 5,144.125 | 35.71 | 54.00 | 18.29 | 10.76 | H | 355 | 2.00 |
| 2 | 5,149.750 | 35.56 | 54.00 | 18.44 | 10.77 | H | 325.6 | 1.00 |
| 2 | 5,231.875 | 79.29 | | | 10.91 | H | 1 | 1.00 |





ANTENNA POLARITY & TEST DISTANCE: VERTICAL AT 3 M

| Rg | Frequency [MHz] | PK+ Level [dBμV/m] | PK+ Limit [dBμV/m] | PK+ Margin [dB] | Correction [dB] | Polarization | Azimuth [deg] | Antenna Height [m] |
|----|-----------------|--------------------|--------------------|-----------------|-----------------|--------------|---------------|--------------------|
| 2 | 5,120.125 | 50.64 | 74.00 | 23.36 | 10.73 | V | 359 | 1.00 |
| 2 | 5,150.125 | 49.67 | 74.00 | 24.33 | 10.77 | V | 5.6 | 1.00 |
| 2 | 5,222.125 | 94.11 | | | 10.92 | V | 163.4 | 2.00 |

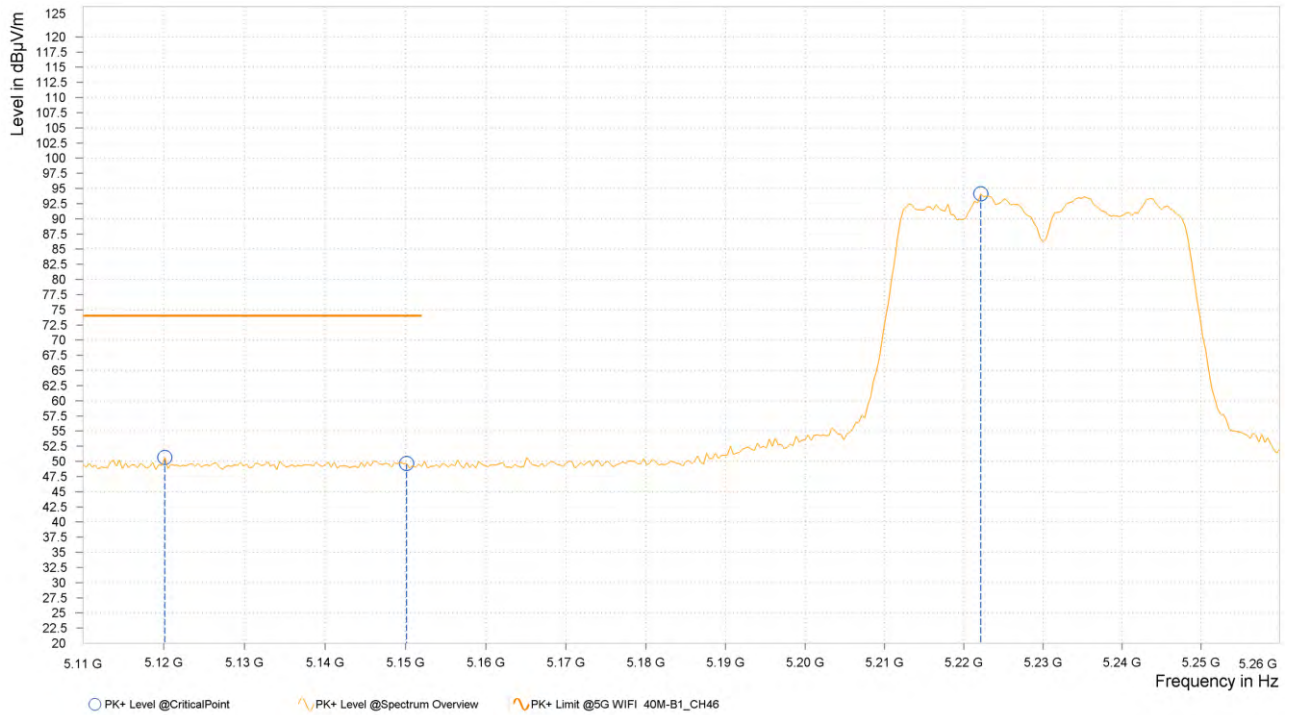



| Rg | Frequency [MHz] | AVG Level [dBμV/m] | AVG Limit [dBμV/m] | AVG Margin [dB] | Correction [dB] | Polarization | Azimuth [deg] | Antenna Height [m] |
|----|-----------------|--------------------|--------------------|-----------------|-----------------|--------------|---------------|--------------------|
| 2 | 5,147.500 | 35.73 | 54.00 | 18.27 | 10.76 | V | 258.7 | 1.00 |
| 2 | 5,150.125 | 35.56 | 54.00 | 18.44 | 10.77 | V | 297.4 | 2.00 |
| 2 | 5,233.375 | 80.84 | | | 10.91 | V | 167 | 2.00 |

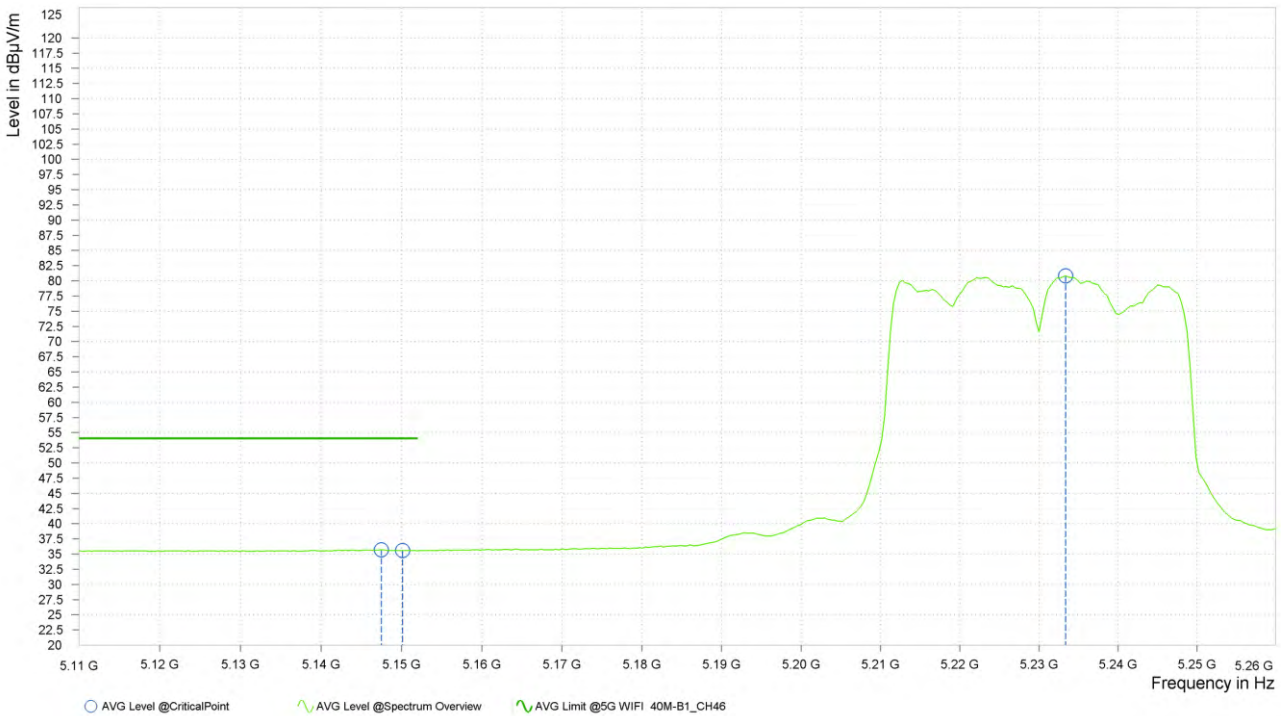

REMARKS:

1. Emission Level = Read Level+ Antenna Factor + Cable Loss- Preamp Factor
Margin value = Limit value- Emission level.
2. 5230MHz: Fundamental frequency.



**BUREAU
VERITAS**

Test Report No.: PSU-NQN2403180115RF03

802.11ac (20MHz)

| | | | |
|------------------------|---------------|--------------------------|--------------|
| CHANNEL | TX Channel 36 | DETECTOR FUNCTION | Peak (PK) |
| FREQUENCY RANGE | 1GHz ~ 40GHz | | Average (AV) |

ANTENNA POLARITY & TEST DISTANCE: HORIZONTAL AT 3 M

| Rg | Frequency [MHz] | PK+ Level [dBμV/m] | PK+ Limit [dBμV/m] | PK+ Margin [dB] | Correction [dB] | Polarization | Azimuth [deg] | Antenna Height [m] |
|----|-----------------|--------------------|--------------------|-----------------|-----------------|--------------|---------------|--------------------|
| 1 | 5,138.500 | 50.39 | 74.00 | 23.61 | 10.75 | H | 73.8 | 2.00 |
| 1 | 5,150.000 | 49.72 | 74.00 | 24.28 | 10.77 | H | 1.4 | 2.00 |
| 1 | 5,181.500 | 93.03 | | | 10.87 | H | 26.7 | 1.00 |

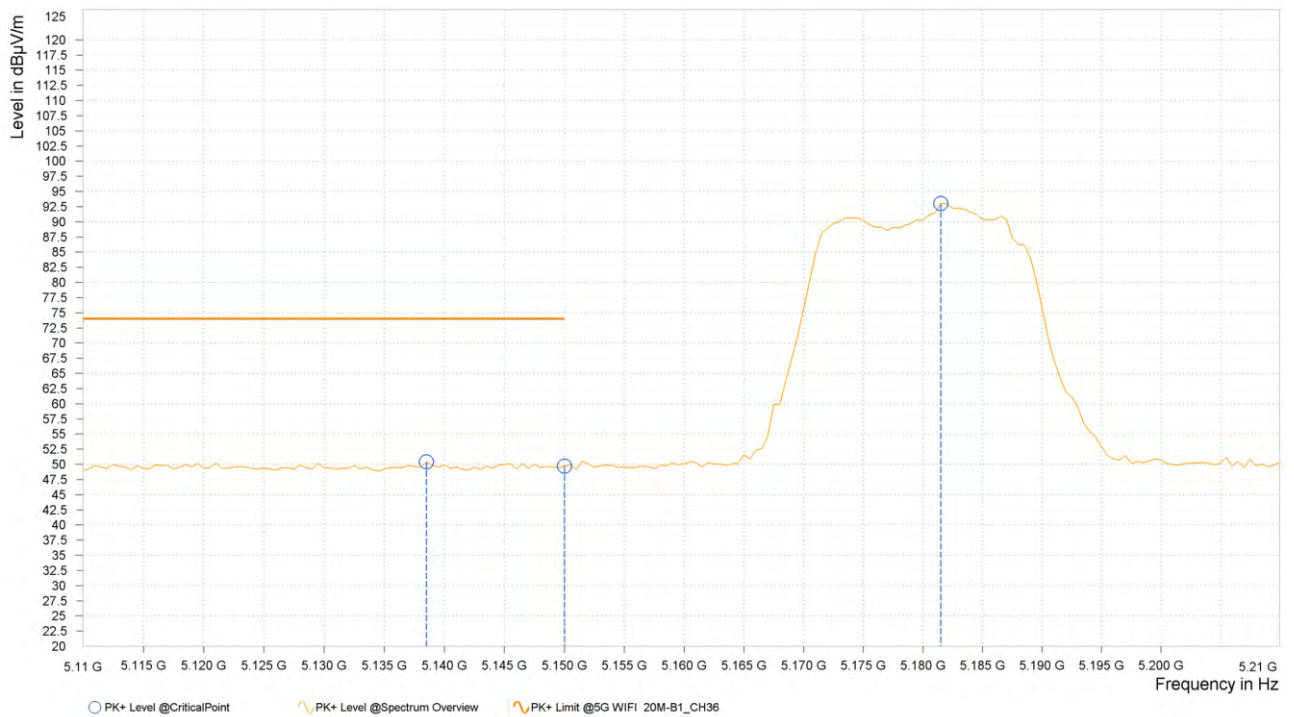



| Rg | Frequency [MHz] | AVG Level [dBμV/m] | AVG Limit [dBμV/m] | AVG Margin [dB] | Correction [dB] | Polarization | Azimuth [deg] | Antenna Height [m] |
|----|-----------------|--------------------|--------------------|-----------------|-----------------|--------------|---------------|--------------------|
| 1 | 5,147.000 | 35.65 | 54.00 | 18.35 | 10.76 | H | 110.5 | 1.00 |
| 1 | 5,150.000 | 35.58 | 54.00 | 18.42 | 10.77 | H | 110.5 | 1.00 |
| 1 | 5,183.500 | 77.31 | | | 10.88 | H | 4.3 | 1.00 |





ANTENNA POLARITY & TEST DISTANCE: VERTICAL AT 3 M

| Rg | Frequency [MHz] | AVG Level [dBμV/m] | AVG Limit [dBμV/m] | AVG Margin [dB] | Correction [dB] | Polarization | Azimuth [deg] | Antenna Height [m] |
|----|-----------------|--------------------|--------------------|-----------------|-----------------|--------------|---------------|--------------------|
| 1 | 5,147.500 | 35.64 | 54.00 | 18.36 | 10.76 | V | 276.6 | 1.00 |
| 1 | 5,150.000 | 35.58 | 54.00 | 18.42 | 10.77 | V | 359.1 | 1.00 |
| 1 | 5,174.500 | 79.12 | | | 10.85 | V | 212.1 | 1.00 |

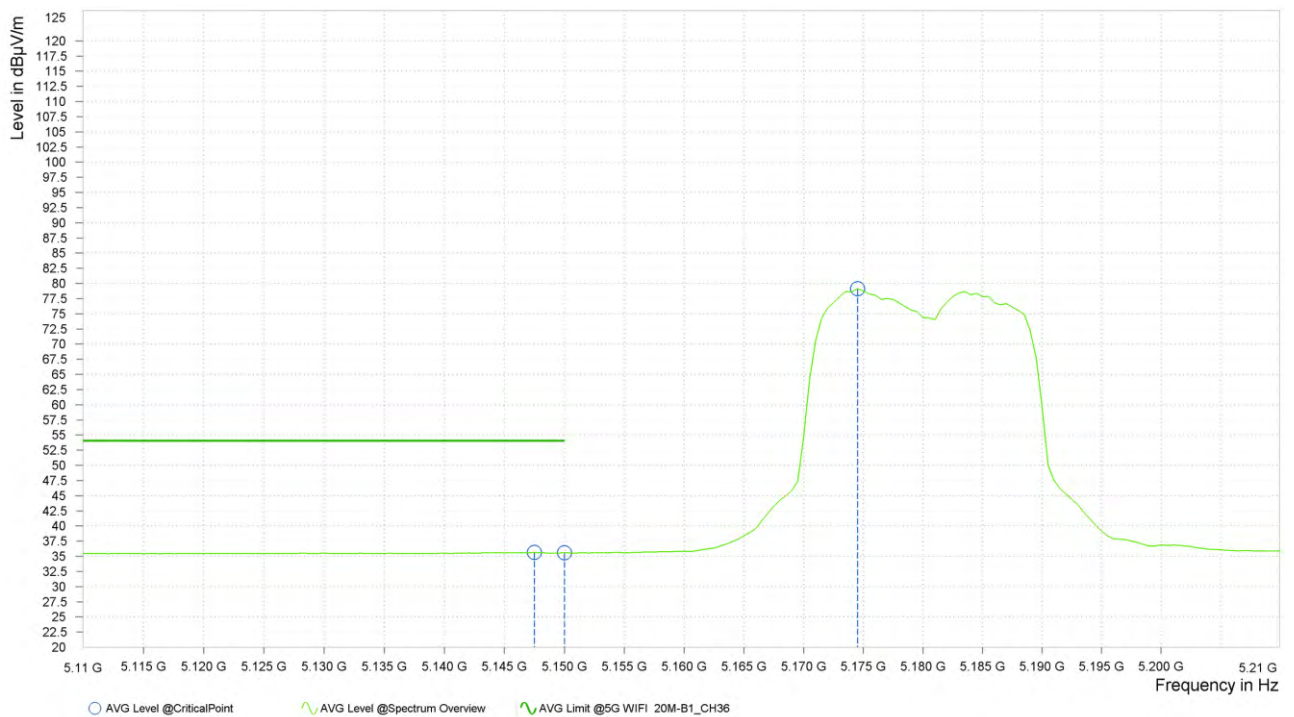



| Rg | Frequency [MHz] | PK+ Level [dBμV/m] | PK+ Limit [dBμV/m] | PK+ Margin [dB] | Correction [dB] | Polarization | Azimuth [deg] | Antenna Height [m] |
|----|-----------------|--------------------|--------------------|-----------------|-----------------|--------------|---------------|--------------------|
| 1 | 5,148.000 | 50.55 | 74.00 | 23.45 | 10.76 | V | 306.9 | 2.00 |
| 1 | 5,150.000 | 50.11 | 74.00 | 23.89 | 10.77 | V | 358.6 | 1.00 |
| 1 | 5,184.000 | 94.01 | | | 10.88 | V | 227.5 | 1.00 |

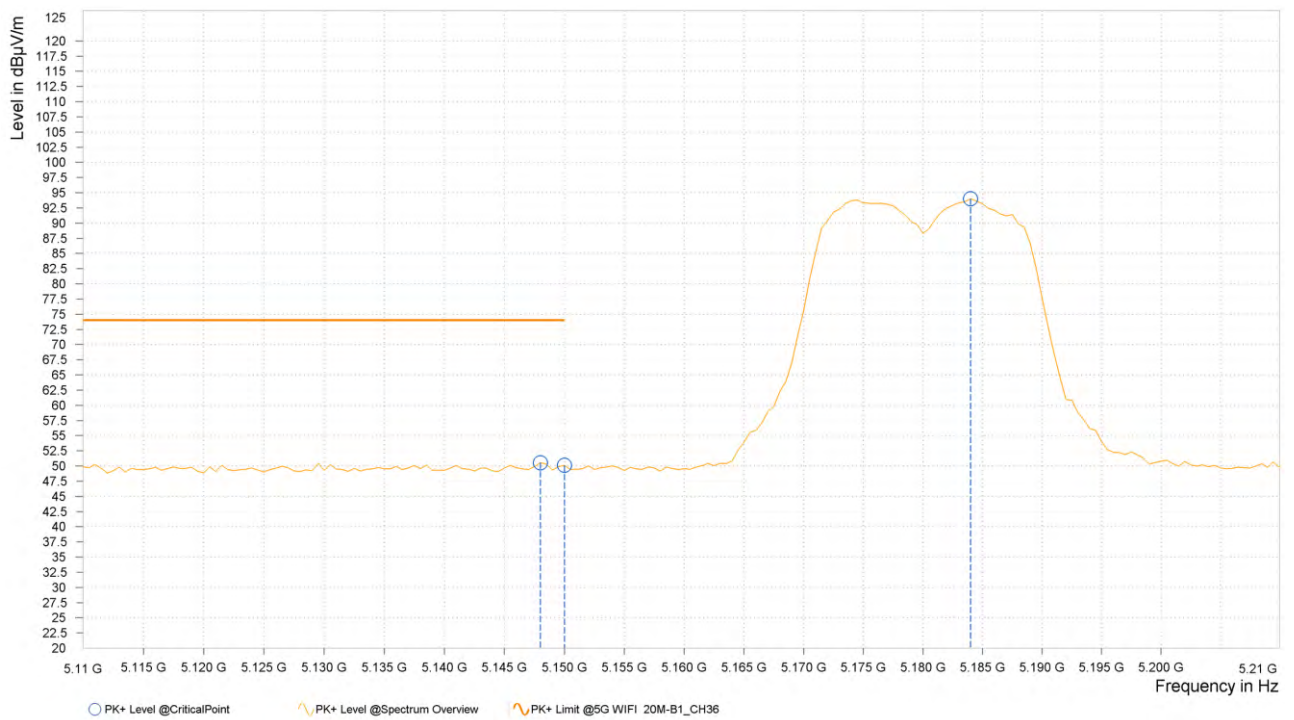

REMARKS:

- Emission Level = Read Level+ Antenna Factor + Cable Loss- Preamp Factor
Margin value = Limit value- Emission level.
- 5180MHz: Fundamental frequency.



**BUREAU
VERITAS**

Test Report No.: PSU-NQN2403180115RF03

| | | | |
|------------------------|---------------|--------------------------|--------------|
| CHANNEL | TX Channel 40 | DETECTOR FUNCTION | Peak (PK) |
| FREQUENCY RANGE | 1GHz ~ 40GHz | | Average (AV) |

ANTENNA POLARITY & TEST DISTANCE: HORIZONTAL AT 3 M

| Rg | Frequency [MHz] | PK+ Level [dBμV/m] | PK+ Limit [dBμV/m] | PK+ Margin [dB] | Correction [dB] | Polarization | Azimuth [deg] | Antenna Height [m] |
|----|-----------------|--------------------|--------------------|-----------------|-----------------|--------------|---------------|--------------------|
| 2 | 5,116.500 | 50.35 | 74.00 | 23.65 | 10.72 | H | 186.2 | 2.00 |
| 2 | 5,150.000 | 48.86 | 74.00 | 25.14 | 10.77 | H | 244.8 | 2.00 |
| 2 | 5,203.000 | 91.95 | | | 10.93 | H | 67.8 | 2.00 |

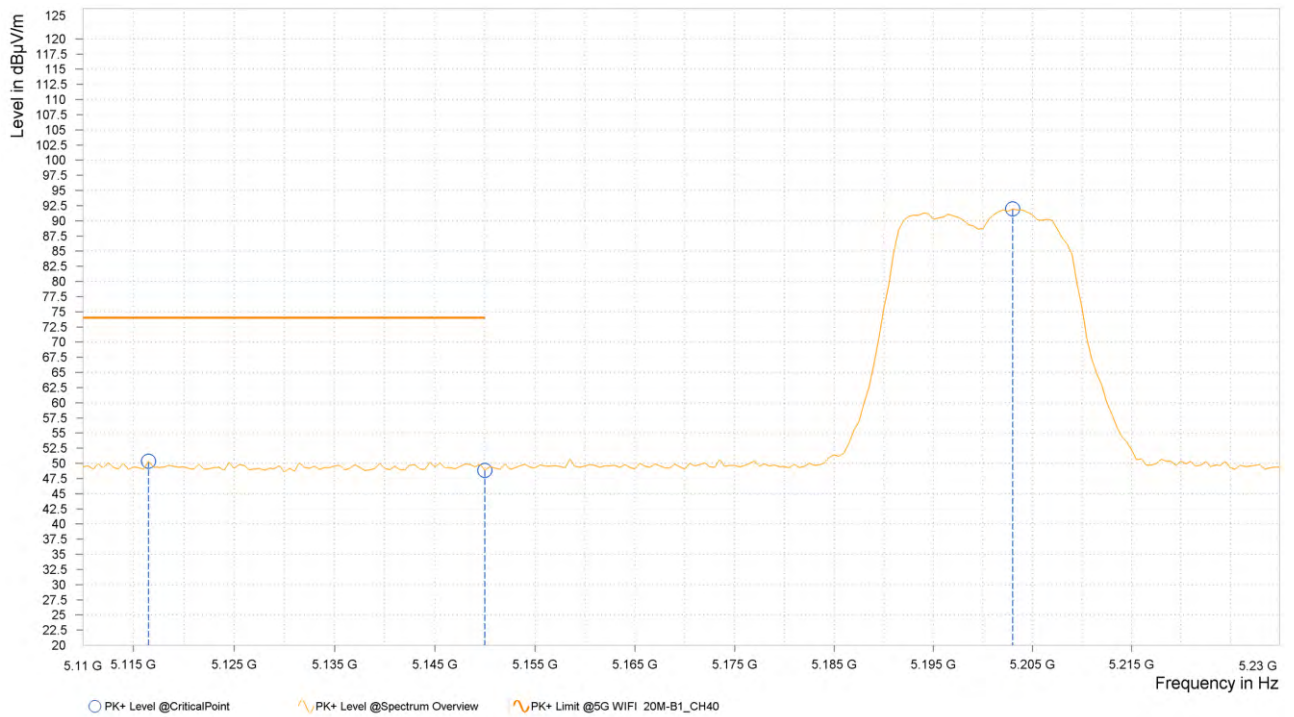



| Rg | Frequency [MHz] | AVG Level [dBμV/m] | AVG Limit [dBμV/m] | AVG Margin [dB] | Correction [dB] | Polarization | Azimuth [deg] | Antenna Height [m] |
|----|-----------------|--------------------|--------------------|-----------------|-----------------|--------------|---------------|--------------------|
| 2 | 5,144.000 | 35.58 | 54.00 | 18.42 | 10.76 | H | 68.6 | 1.00 |
| 2 | 5,150.000 | 35.51 | 54.00 | 18.49 | 10.77 | H | 1.1 | 2.00 |
| 2 | 5,203.000 | 78.22 | | | 10.93 | H | 68.6 | 1.00 |





ANTENNA POLARITY & TEST DISTANCE: VERTICAL AT 3 M

| Rg | Frequency [MHz] | PK+ Level [dBμV/m] | PK+ Limit [dBμV/m] | PK+ Margin [dB] | Correction [dB] | Polarization | Azimuth [deg] | Antenna Height [m] |
|----|-----------------|--------------------|--------------------|-----------------|-----------------|--------------|---------------|--------------------|
| 2 | 5,127.000 | 50.82 | 74.00 | 23.18 | 10.74 | V | 188.6 | 2.00 |
| 2 | 5,150.000 | 49.13 | 74.00 | 24.87 | 10.77 | V | 305.6 | 2.00 |
| 2 | 5,202.000 | 95.20 | | | 10.93 | V | 188.6 | 2.00 |

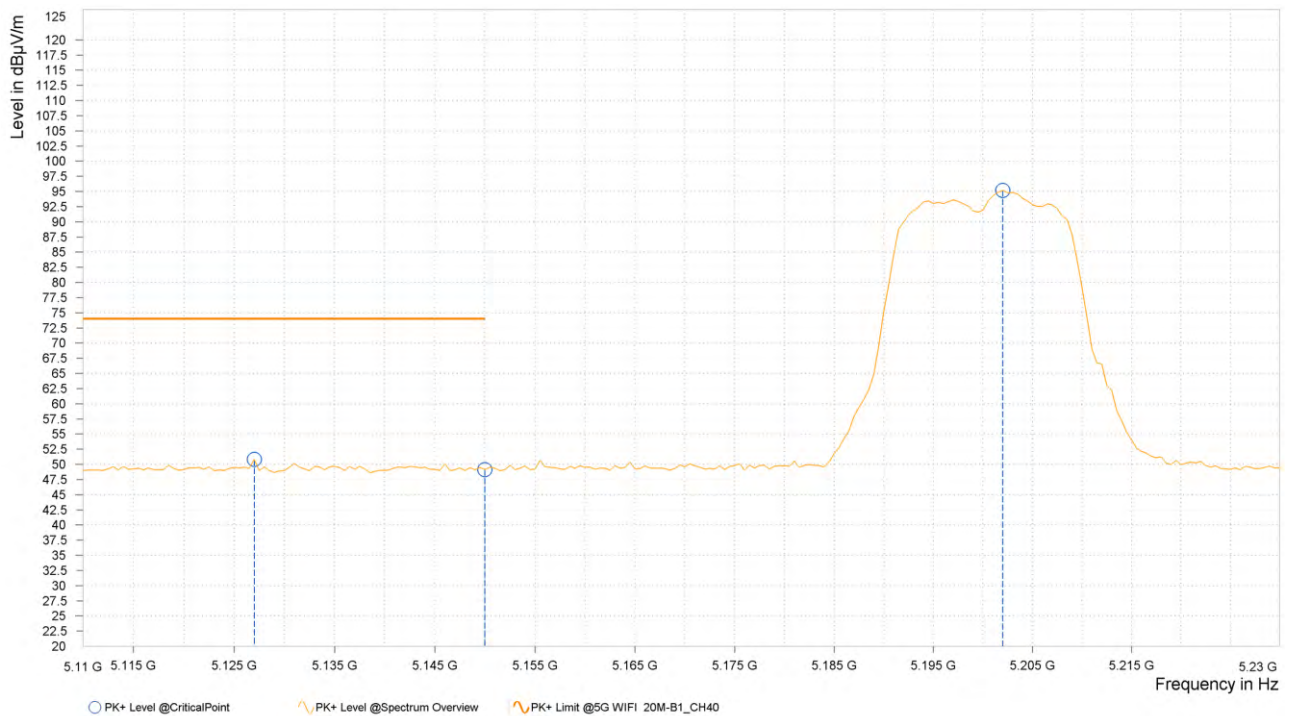



| Rg | Frequency [MHz] | AVG Level [dBμV/m] | AVG Limit [dBμV/m] | AVG Margin [dB] | Correction [dB] | Polarization | Azimuth [deg] | Antenna Height [m] |
|----|-----------------|--------------------|--------------------|-----------------|-----------------|--------------|---------------|--------------------|
| 2 | 5,142.500 | 35.60 | 54.00 | 18.40 | 10.76 | V | 359 | 1.00 |
| 2 | 5,150.000 | 35.52 | 54.00 | 18.48 | 10.77 | V | 1 | 1.00 |
| 2 | 5,204.500 | 79.47 | | | 10.93 | V | 232.3 | 1.00 |



REMARKS:

1. Emission Level = Read Level+ Antenna Factor + Cable Loss- Preamp Factor
Margin value = Limit value- Emission level.
2. 5200MHz: Fundamental frequency.



**BUREAU
VERITAS**

Test Report No.: PSU-NQN2403180115RF03

| | | | |
|------------------------|---------------|--------------------------|--------------|
| CHANNEL | TX Channel 48 | DETECTOR FUNCTION | Peak (PK) |
| FREQUENCY RANGE | 1GHz ~ 40GHz | | Average (AV) |

ANTENNA POLARITY & TEST DISTANCE: HORIZONTAL AT 3 M

| Rg | Frequency [MHz] | PK+ Level [dBμV/m] | PK+ Limit [dBμV/m] | PK+ Margin [dB] | Correction [dB] | Polarization | Azimuth [deg] | Antenna Height [m] |
|----|-----------------|--------------------|--------------------|-----------------|-----------------|--------------|---------------|--------------------|
| 3 | 5,147.000 | 50.30 | 74.00 | 23.70 | 10.76 | H | 0.9 | 2.00 |
| 3 | 5,150.000 | 48.99 | 74.00 | 25.01 | 10.77 | H | 5.6 | 1.00 |
| 3 | 5,243.000 | 92.81 | | | 10.90 | H | 359 | 2.00 |



BV 7Layers Communications Technology
(Shenzhen) Co., Ltd

Room B37, Warehouse A5, No.3 Chiwan 4th Road,
Zhaoshang Street, Nanshan District Shenzhen,
Guangdong, People's Republic of China

Tel: +86 755 8869 6566
Fax: +86 755 8869 6577
Email: customerservice.sw@bureauveritas.com



| Rg | Frequency [MHz] | AVG Level [dBμV/m] | AVG Limit [dBμV/m] | AVG Margin [dB] | Correction [dB] | Polarization | Azimuth [deg] | Antenna Height [m] |
|----|-----------------|--------------------|--------------------|-----------------|-----------------|--------------|---------------|--------------------|
| 3 | 5,145.000 | 35.61 | 54.00 | 18.39 | 10.76 | H | 1 | 2.00 |
| 3 | 5,150.000 | 35.50 | 54.00 | 18.50 | 10.77 | H | 237.2 | 1.00 |
| 3 | 5,243.500 | 77.81 | | | 10.90 | H | 359 | 2.00 |





ANTENNA POLARITY & TEST DISTANCE: VERTICAL AT 3 M

| Rg | Frequency [MHz] | PK+ Level [dBμV/m] | PK+ Limit [dBμV/m] | PK+ Margin [dB] | Correction [dB] | Polarization | Azimuth [deg] | Antenna Height [m] |
|----|-----------------|--------------------|--------------------|-----------------|-----------------|--------------|---------------|--------------------|
| 3 | 5,147.000 | 51.22 | 74.00 | 22.78 | 10.76 | V | 125.2 | 2.00 |
| 3 | 5,150.000 | 49.08 | 74.00 | 24.92 | 10.77 | V | 305.7 | 2.00 |
| 3 | 5,244.000 | 95.12 | | | 10.90 | V | 305.7 | 2.00 |

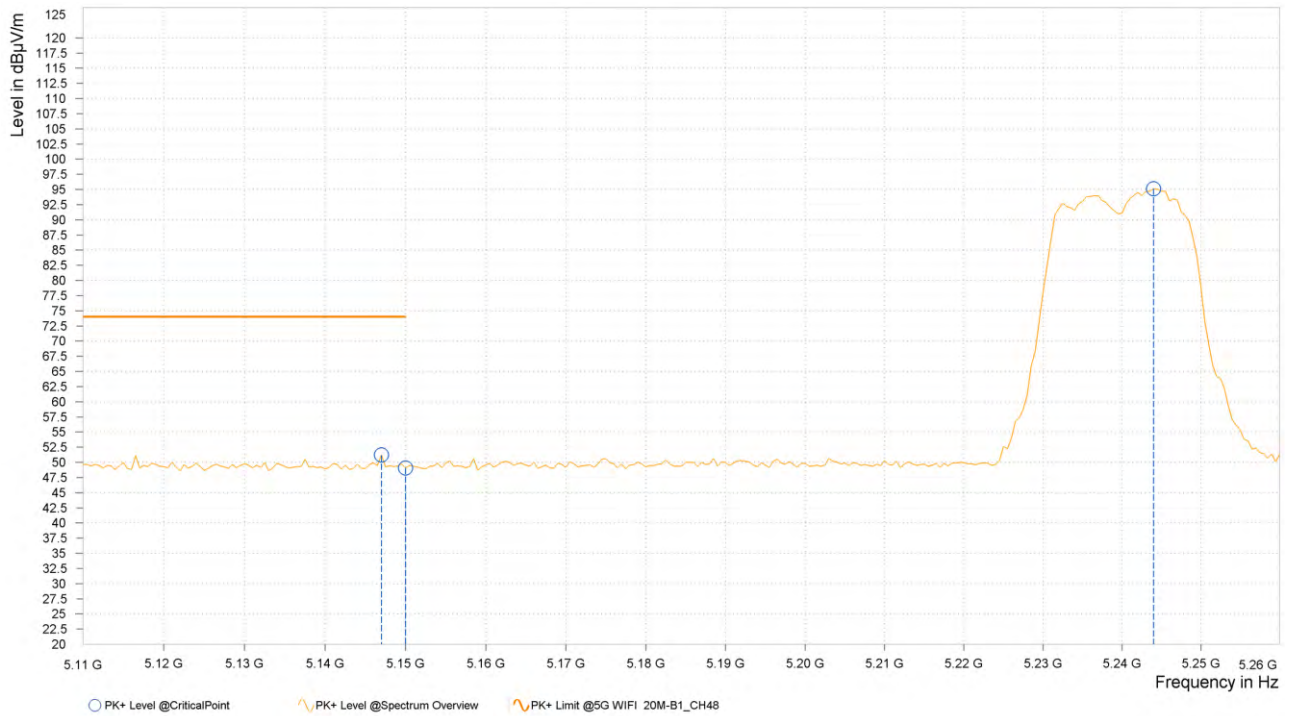



| Rg | Frequency [MHz] | AVG Level [dBμV/m] | AVG Limit [dBμV/m] | AVG Margin [dB] | Correction [dB] | Polarization | Azimuth [deg] | Antenna Height [m] |
|----|-----------------|--------------------|--------------------|-----------------|-----------------|--------------|---------------|--------------------|
| 3 | 5,149.000 | 35.55 | 54.00 | 18.45 | 10.76 | V | 117.6 | 1.00 |
| 3 | 5,150.000 | 35.49 | 54.00 | 18.51 | 10.77 | V | 359 | 1.00 |
| 3 | 5,243.500 | 79.95 | | | 10.90 | V | 305.7 | 2.00 |

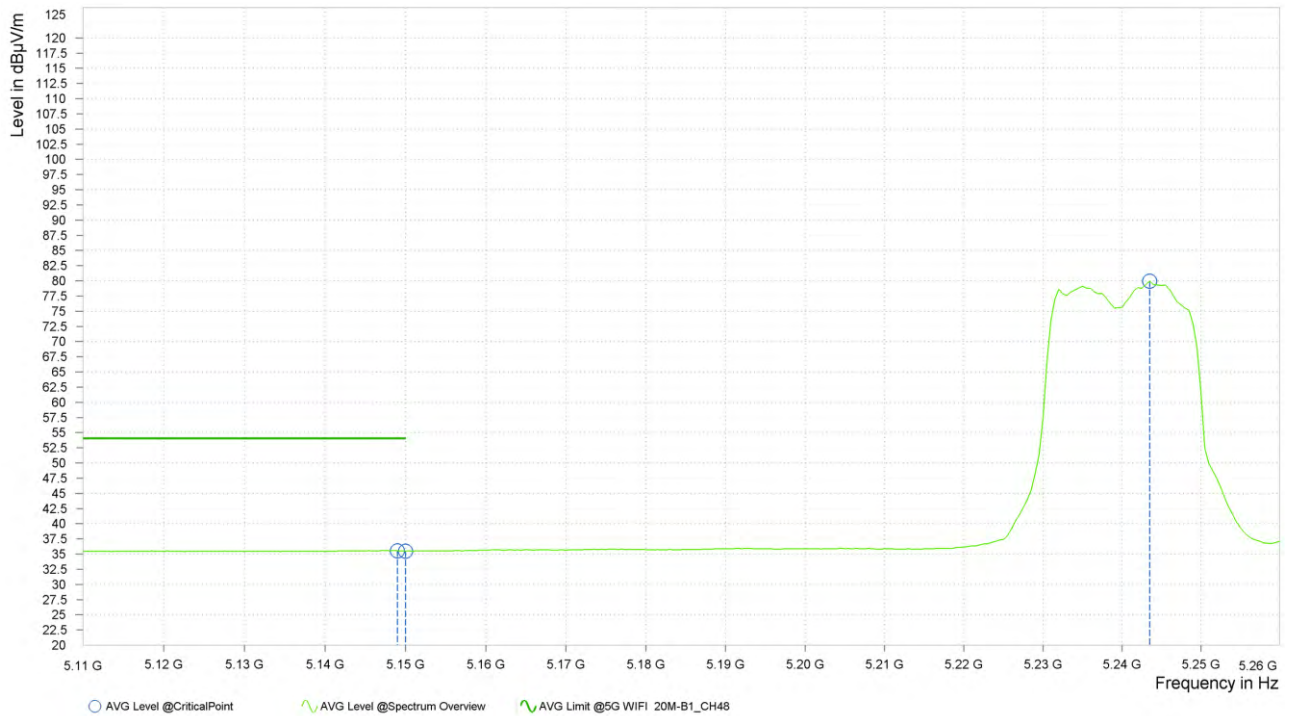

REMARKS:

1. Emission Level = Read Level+ Antenna Factor + Cable Loss- Preamp Factor
Margin value = Limit value- Emission level.
2. 5240MHz: Fundamental frequency.



**BUREAU
VERITAS**

Test Report No.: PSU-NQN2403180115RF03

802.11ac (40MHz)

| | | | |
|------------------------|---------------|--------------------------|--------------|
| CHANNEL | TX Channel 38 | DETECTOR FUNCTION | Peak (PK) |
| FREQUENCY RANGE | 1GHz ~ 40GHz | | Average (AV) |

ANTENNA POLARITY & TEST DISTANCE: HORIZONTAL AT 3 M

| Rg | Frequency [MHz] | PK+ Level [dBμV/m] | PK+ Limit [dBμV/m] | PK+ Margin [dB] | Correction [dB] | Polarization | Azimuth [deg] | Antenna Height [m] |
|----|-----------------|--------------------|--------------------|-----------------|-----------------|--------------|---------------|--------------------|
| 1 | 5,138.000 | 50.81 | 74.00 | 23.19 | 10.75 | H | 66.2 | 1.00 |
| 1 | 5,150.000 | 49.91 | 74.00 | 24.09 | 10.77 | H | 157.5 | 2.00 |
| 1 | 5,193.000 | 91.15 | | | 10.91 | H | 359 | 2.00 |





| Rg | Frequency [MHz] | AVG Level [dBμV/m] | AVG Limit [dBμV/m] | AVG Margin [dB] | Correction [dB] | Polarization | Azimuth [deg] | Antenna Height [m] |
|----|-----------------|--------------------|--------------------|-----------------|-----------------|--------------|---------------|--------------------|
| 1 | 5,146.500 | 35.78 | 54.00 | 18.22 | 10.76 | H | 1 | 2.00 |
| 1 | 5,150.000 | 35.83 | 54.00 | 18.17 | 10.77 | H | 1 | 2.00 |
| 1 | 5,192.500 | 75.42 | | | 10.91 | H | 359 | 2.00 |

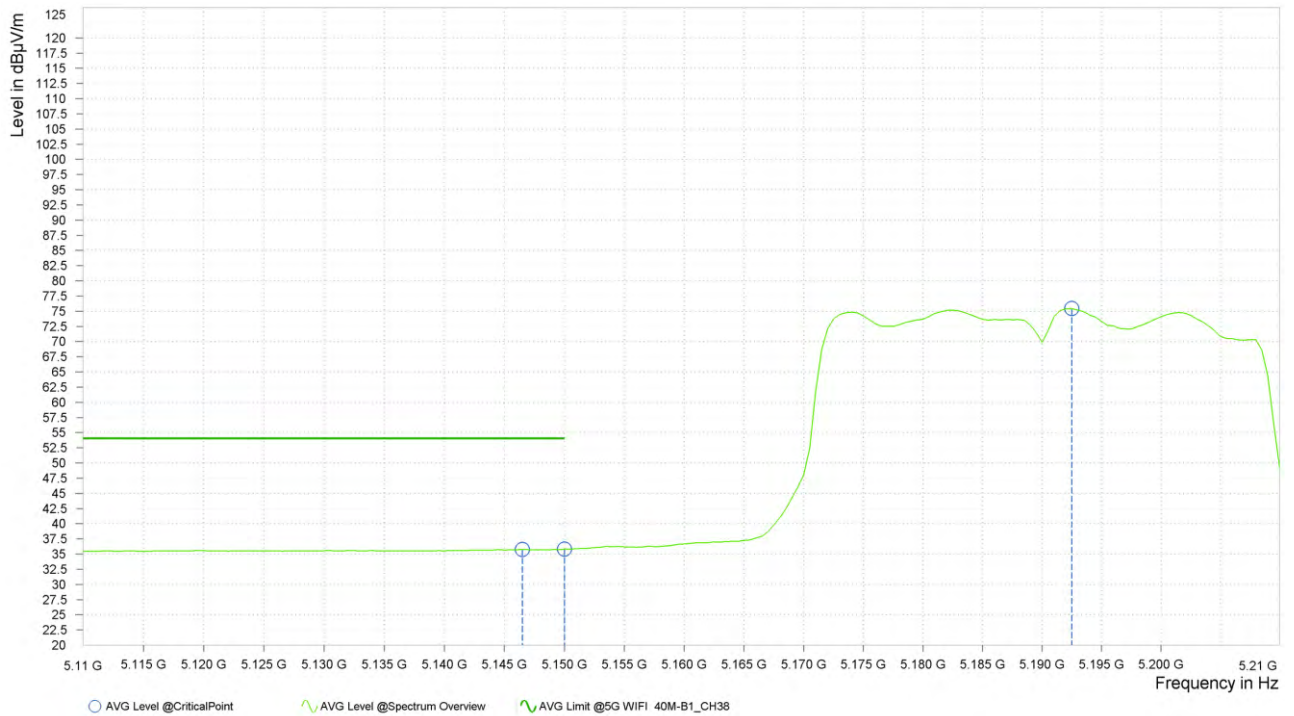



ANTENNA POLARITY & TEST DISTANCE: VERTICAL AT 3 M

| Rg | Frequency [MHz] | PK+ Level [dBμV/m] | PK+ Limit [dBμV/m] | PK+ Margin [dB] | Correction [dB] | Polarization | Azimuth [deg] | Antenna Height [m] |
|----|-----------------|--------------------|--------------------|-----------------|-----------------|--------------|---------------|--------------------|
| 1 | 5,118.500 | 50.83 | 74.00 | 23.17 | 10.73 | V | 351.8 | 1.00 |
| 1 | 5,150.000 | 49.50 | 74.00 | 24.50 | 10.77 | V | 1 | 2.00 |
| 1 | 5,185.000 | 93.23 | | | 10.88 | V | 210.9 | 1.00 |

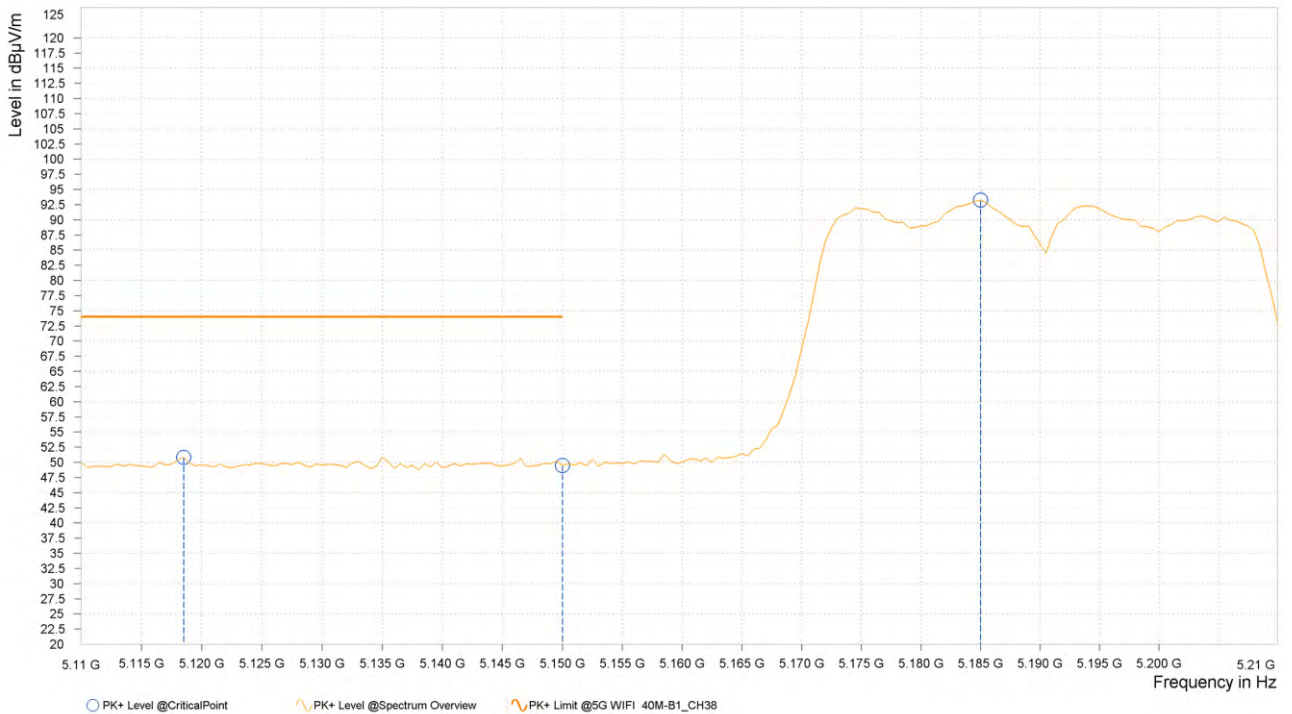



| Rg | Frequency [MHz] | AVG Level [dBμV/m] | AVG Limit [dBμV/m] | AVG Margin [dB] | Correction [dB] | Polarization | Azimuth [deg] | Antenna Height [m] |
|----|-----------------|--------------------|--------------------|-----------------|-----------------|--------------|---------------|--------------------|
| 1 | 5,146.000 | 35.91 | 54.00 | 18.09 | 10.76 | V | 156.2 | 2.00 |
| 1 | 5,149.500 | 35.84 | 54.00 | 18.16 | 10.77 | V | 156.2 | 2.00 |
| 1 | 5,184.000 | 76.20 | | | 10.88 | V | 238.4 | 1.00 |



REMARKS:

- Emission Level = Read Level+ Antenna Factor + Cable Loss- Preamp Factor
Margin value = Limit value- Emission level.
- 5190MHz: Fundamental frequency.



**BUREAU
VERITAS**

Test Report No.: PSU-NQN2403180115RF03

| | | | |
|------------------------|---------------|--------------------------|--------------|
| CHANNEL | TX Channel 46 | DETECTOR FUNCTION | Peak (PK) |
| FREQUENCY RANGE | 1GHz ~ 40GHz | | Average (AV) |

ANTENNA POLARITY & TEST DISTANCE: HORIZONTAL AT 3 M

| Rg | Frequency [MHz] | PK+ Level [dBμV/m] | PK+ Limit [dBμV/m] | PK+ Margin [dB] | Correction [dB] | Polarization | Azimuth [deg] | Antenna Height [m] |
|----|-----------------|--------------------|--------------------|-----------------|-----------------|--------------|---------------|--------------------|
| 2 | 5,128.375 | 50.27 | 74.00 | 23.73 | 10.74 | H | 4.9 | 1.00 |
| 2 | 5,150.125 | 49.30 | 74.00 | 24.70 | 10.77 | H | 141.5 | 1.00 |
| 2 | 5,231.875 | 91.61 | | | 10.91 | H | 359 | 2.00 |

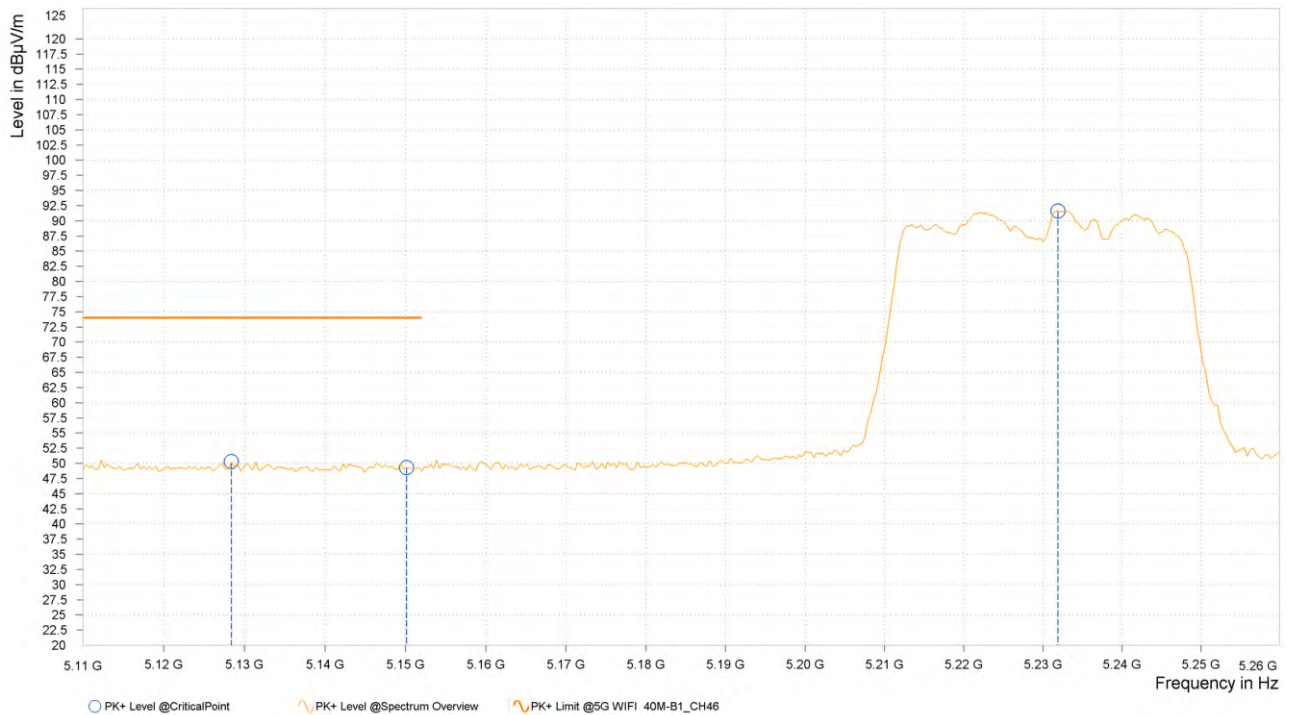

BV 7Layers Communications Technology
(Shenzhen) Co., Ltd

Room B37, Warehouse A5, No.3 Chiwan 4th Road,
Zhaoshang Street, Nanshan District Shenzhen,
Guangdong, People's Republic of China

Tel: +86 755 8869 6566
Fax: +86 755 8869 6577
Email: customerservice.sw@bureauveritas.com



| Rg | Frequency [MHz] | AVG Level [dBμV/m] | AVG Limit [dBμV/m] | AVG Margin [dB] | Correction [dB] | Polarization | Azimuth [deg] | Antenna Height [m] |
|----|-----------------|--------------------|--------------------|-----------------|-----------------|--------------|---------------|--------------------|
| 2 | 5,146.000 | 35.74 | 54.00 | 18.26 | 10.76 | H | 355 | 2.00 |
| 2 | 5,150.125 | 35.57 | 54.00 | 18.43 | 10.77 | H | 292.6 | 2.00 |
| 2 | 5,232.250 | 75.88 | | | 10.91 | H | 359 | 2.00 |





ANTENNA POLARITY & TEST DISTANCE: VERTICAL AT 3 M

| Rg | Frequency [MHz] | PK+ Level [dBμV/m] | PK+ Limit [dBμV/m] | PK+ Margin [dB] | Correction [dB] | Polarization | Azimuth [deg] | Antenna Height [m] |
|----|-----------------|--------------------|--------------------|-----------------|-----------------|--------------|---------------|--------------------|
| 2 | 5,130.250 | 50.64 | 74.00 | 23.36 | 10.74 | V | 359 | 1.00 |
| 2 | 5,150.125 | 49.66 | 74.00 | 24.34 | 10.77 | V | 1 | 2.00 |
| 2 | 5,243.875 | 93.11 | | | 10.90 | V | 213.3 | 1.00 |

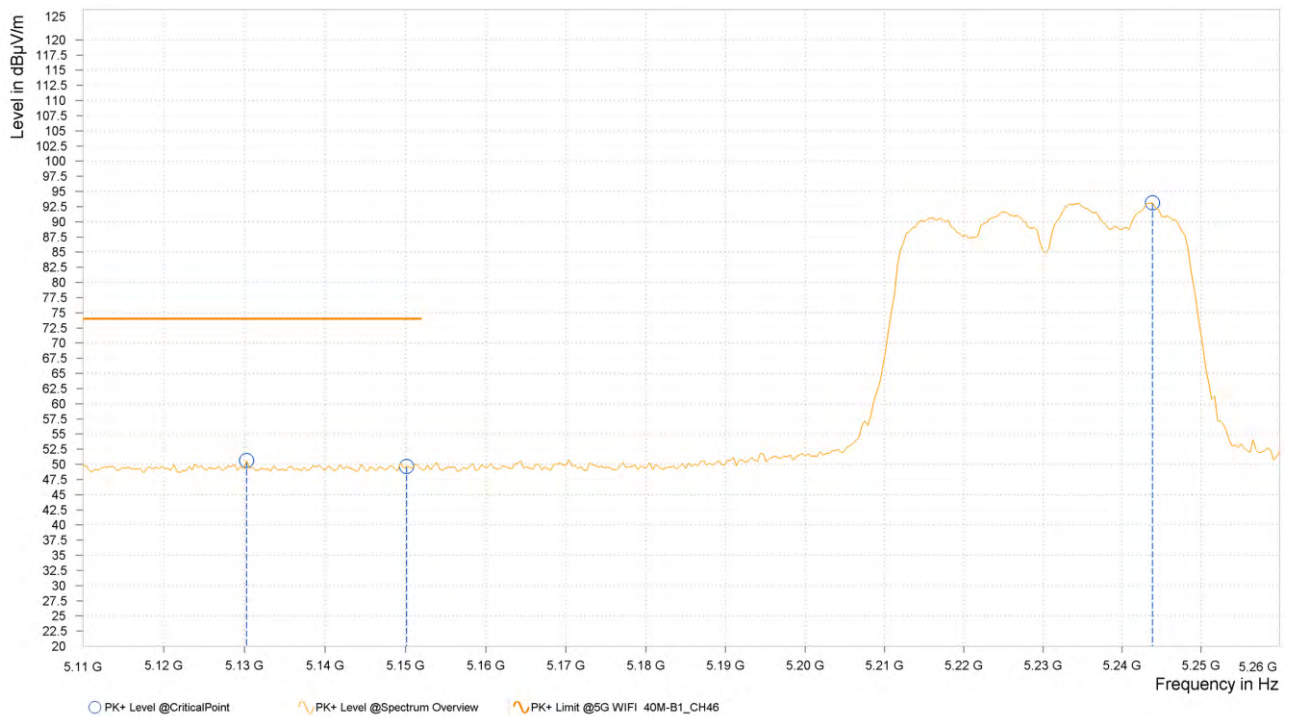



| Rg | Frequency [MHz] | AVG Level [dBμV/m] | AVG Limit [dBμV/m] | AVG Margin [dB] | Correction [dB] | Polarization | Azimuth [deg] | Antenna Height [m] |
|----|-----------------|--------------------|--------------------|-----------------|-----------------|--------------|---------------|--------------------|
| 2 | 5,147.125 | 35.76 | 54.00 | 18.24 | 10.76 | V | 153.9 | 2.00 |
| 2 | 5,150.125 | 35.66 | 54.00 | 18.34 | 10.77 | V | 153.9 | 2.00 |
| 2 | 5,233.750 | 77.31 | | | 10.91 | V | 210.9 | 1.00 |



REMARKS:

- Emission Level = Read Level+ Antenna Factor + Cable Loss- Preamp Factor
Margin value = Limit value- Emission level.
- 5230MHz: Fundamental frequency.



802.11ac (80MHz)

| | | | |
|------------------------|---------------|--------------------------|--------------|
| CHANNEL | TX Channel 42 | DETECTOR FUNCTION | Peak (PK) |
| FREQUENCY RANGE | 1GHz ~ 40GHz | | Average (AV) |

ANTENNA POLARITY & TEST DISTANCE: HORIZONTAL AT 3 M

| Rg | Frequency [MHz] | PK+ Level [dBμV/m] | PK+ Limit [dBμV/m] | PK+ Margin [dB] | Correction [dB] | Polarization | Azimuth [deg] | Antenna Height [m] |
|----|-----------------|--------------------|--------------------|-----------------|-----------------|--------------|---------------|--------------------|
| 1 | 5,143.150 | 50.40 | 74.00 | 23.60 | 10.76 | H | 143.9 | 1.00 |
| 1 | 5,149.950 | 49.40 | 74.00 | 24.60 | 10.77 | H | 1 | 1.00 |
| 1 | 5,221.775 | 88.41 | | | 10.92 | H | 359 | 2.00 |

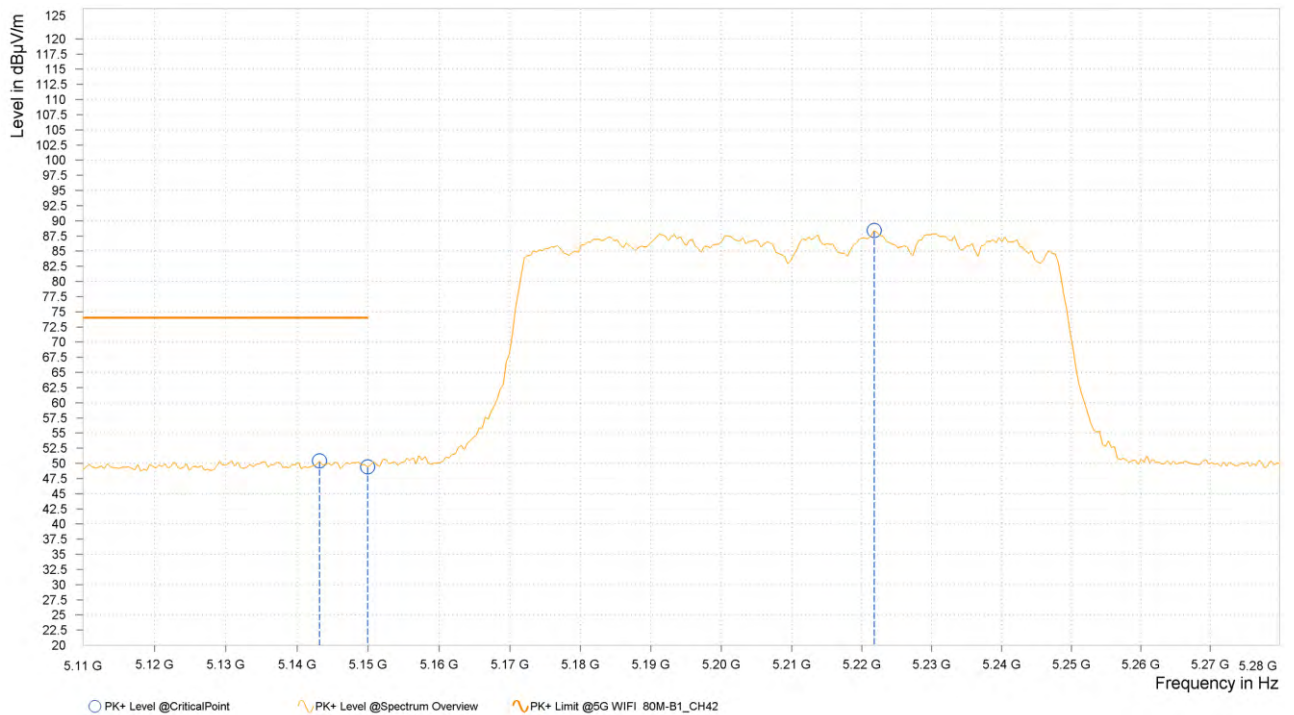



| Rg | Frequency [MHz] | AVG Level [dBμV/m] | AVG Limit [dBμV/m] | AVG Margin [dB] | Correction [dB] | Polarization | Azimuth [deg] | Antenna Height [m] |
|----|-----------------|--------------------|--------------------|-----------------|-----------------|--------------|---------------|--------------------|
| 1 | 5,145.700 | 36.46 | 54.00 | 17.54 | 10.76 | H | 355 | 2.00 |
| 1 | 5,149.950 | 36.30 | 54.00 | 17.70 | 10.77 | H | 355 | 2.00 |
| 1 | 5,221.775 | 73.13 | | | 10.92 | H | 359 | 2.00 |

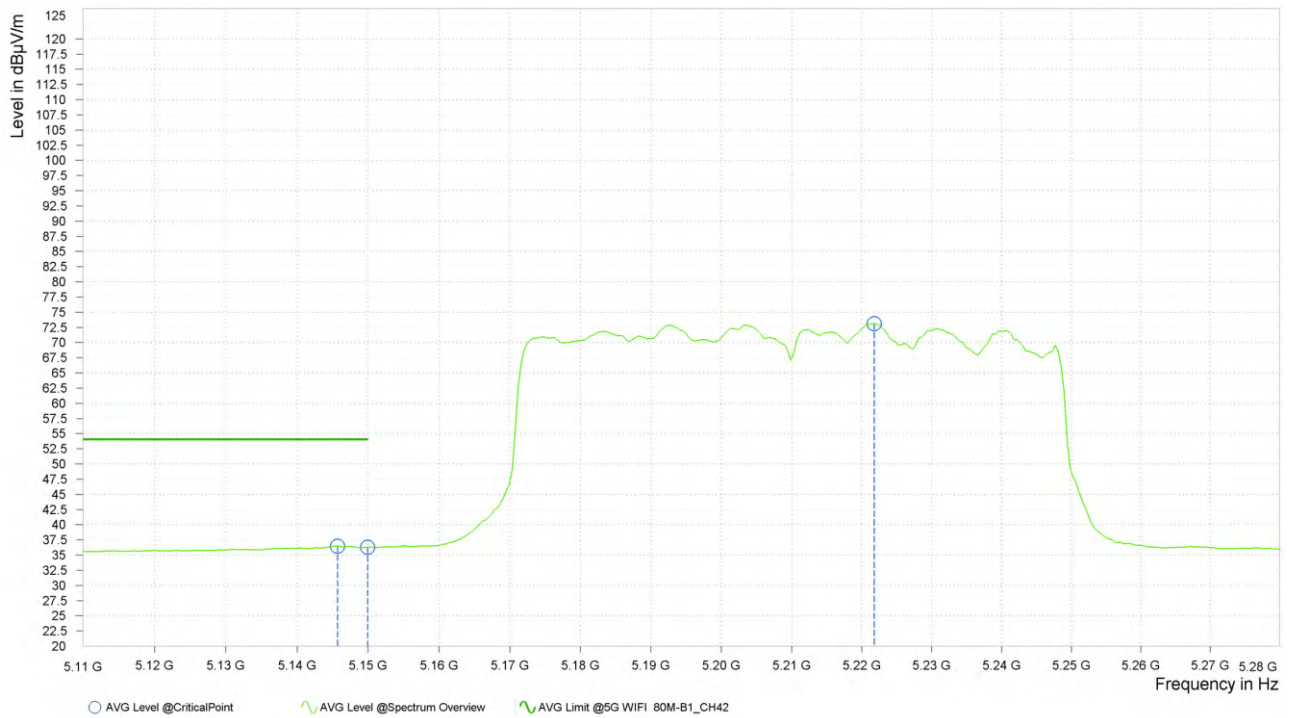



ANTENNA POLARITY & TEST DISTANCE: VERTICAL AT 3 M

| Rg | Frequency [MHz] | PK+ Level [dBμV/m] | PK+ Limit [dBμV/m] | PK+ Margin [dB] | Correction [dB] | Polarization | Azimuth [deg] | Antenna Height [m] |
|----|-----------------|--------------------|--------------------|-----------------|-----------------|--------------|---------------|--------------------|
| 1 | 5,143.150 | 51.50 | 74.00 | 22.50 | 10.76 | V | 215 | 2.00 |
| 1 | 5,149.950 | 49.63 | 74.00 | 24.37 | 10.77 | V | 215 | 2.00 |
| 1 | 5,234.950 | 89.94 | | | 10.91 | V | 232.4 | 1.00 |

