

HAC TEST REPORT

Applicant	HMD Global Oy
FCC ID	2AJOTTA-1590
Product	Smartphone
Brand	HMD
Model	TA-1590
Report No.	R2401A0092-H2
Issue Date	March 11, 2024

Prepared by: Wei Fangying

Approved by: Fan Guangchang

TA Technology (Shanghai) Co., Ltd.

Building 3, No.145, Jintang Rd, Pudong Shanghai, P.R.China

TEL: +86-021-50791141/2/3

FAX: +86-021-50791141/2/3-8000

Table of Contents

1	Test Laboratory	3
1.1	Notes of the Test Report.....	3
1.2	Testing Location.....	3
1.3	Laboratory Environment	3
2	Statement of Compliance.....	4
3	Description of Equipment under Test.....	5
4	Test Specification and Operational Conditions	8
4.1	Test Specification	8
5	Test Information.....	9
5.1	Operational Conditions during Test.....	9
5.1.1	General Description of Test Procedures	9
5.2	T-Coil Measurements System Configuration.....	10
5.2.1	T-coil Measurement Set-up for OTT.....	10
5.2.2	AM1D Probe	11
5.2.3	Audio Magnetic Measurement Instrument (AMMI).....	13
5.2.4	Helmholtz Calibration Coil (AMCC).....	14
5.2.5	Test Arch Phantom & Phone Positioner.....	14
5.3	T-Coil measurement points and reference plane.....	15
6	T-Coil Performance Requirements	17
6.1	T-Coil coupling qualifying field strengths.....	17
6.2	Frequency response	17
6.3	Desired ABM signal, undesired ABM field qualification requirements	18
6.3.1	Non-2G GSM operating modes	19
6.3.2	2G GSM operating modes	19
7	T-Coil testing for OTT.....	20
8	Air Interface Investigation Test Results.....	23
9	Measurement Uncertainty.....	29
10	Main Test Instruments	30
	ANNEX A: Test Layout	31
	ANNEX B: Graph Results.....	32
	ANNEX C: Probe Calibration Certificate	96
	ANNEX D: DAE4 Calibration Certificate	99
	ANNEX E: The EUT Appearances	102
	ANNEX F: Test Setup Photos	103
	ANNEX G: Product Change Description.....	104

1 Test Laboratory

1.1 Notes of the Test Report

This report shall not be reproduced in full or partial, without the written approval of **TA Technology (Shanghai) Co., Ltd.** The results documented in this report apply only to the tested sample, under the conditions and modes of operation as described herein .Measurement Uncertainties were not taken into account and are published for informational purposes only. This report is written to support regulatory compliance of the applicable standards stated above.

1.2 Testing Location

Company: TA Technology (Shanghai) Co., Ltd.
 Address: Building 3, No.145, Jintang Rd, Pudong Shanghai, P.R.China
 City: Shanghai
 Post code: 201201
 Country: P. R. China
 Contact: Fan Guangchang
 Telephone: +86-021-50791141/2/3
 Fax: +86-021-50791141/2/3-8000
 Website: <https://www.eurofins.com/electrical-and-electronics>
 E-mail: Jack.Fan@cpt.eurofinscn.com

1.3 Laboratory Environment

Temperature	Min. = 18°C, Max. = 28 °C
Relative humidity	Min. = 0%, Max. = 80%
Ground system resistance	< 0.5 Ω
Ambient noise is checked and found very low and in compliance with requirement of standards. Reflection of surrounding objects is minimized and in compliance with requirement of standards.	

2 Statement of Compliance

Mode	Statement of Compliance
GSM 850	Pass
GSM 1900	Pass
WCDMA Band II	Pass
WCDMA Band V	Pass
LTE Band 2	Pass
LTE Band 5	Pass
LTE Band 12	Pass
LTE Band 13	Pass
LTE Band 66 (LTE Band 4)	Pass
Wi-Fi (2.4G)	Pass
Wi-Fi (5G)	Pass
Date of Testing: January 23, 2024 ~ January 30, 2024	
Date of Sample Received: January 18, 2024	
Note:	
<ol style="list-style-type: none"> 1. According to TCB workshop October, 2014 RF Exposure Procedures Update (Overlapping LTE Bands): <ol style="list-style-type: none"> a) HAC for LTE Band 4 (Frequency range 1710-1755 MHz) is covered by LTE Band 66 (Frequency range: 1710-1780 MHz) due to similar frequency range, same maximum tune up limit and same channel bandwidth. 2. All indications of Pass/Fail in this report are opinions expressed by TA Technology (Shanghai) Co., Ltd. based on interpretations and/or observations of test results. Measurement Uncertainties were not taken into account and are published for informational purposes only. 	

TA-1590 (Report No.: R2401A0092-H2) is a variant model of N159V (Report No.: R2401A0092-H1).

The detailed product changes are as follows:

- 1. HW:** The TA-1590 product has only 6+128 memory; the memory of the N159V product is 3+64. The hardware is the same except the memory, and there is no change of the hardware version number.
- 2. SW:** On the basis of N159V, some customized applications on the software are removed, and the software version number is changed.
- 3. The product model is different:** N159V and TA-1590.

There is no test for variant in this report. Test values all duplicated from original report.

The detailed product change description please refers to the *Difference Declaration Letter*.

3 Description of Equipment under Test

Client Information

Applicant	HMD Global Oy
Applicant address	Bertel Jungin aukio 9 Espoo 02600 Finland
Manufacturer	HMD Global Oy
Manufacturer address	Bertel Jungin aukio 9 Espoo 02600 Finland

General Technologies

EUT Description			
Device Type:	Portable Device		
EUT Stage	Production Unit		
Model	TA-1590		
IMEI:	Original	First Supply	353407230018673
		Second Supply	353407230025157
Hardware Version	V 1.0		
Software Version	00US_0_100		
Antenna Type	Internal Antenna		
Power Class:	GSM 850: 4 GSM 1900: 1 WCDMA Band II/V: 3 LTE FDD 2/4/5/12/13:3 LTE TDD 66:3		
Power Level	GSM 850: level 5 GSM 1900: level 0 WCDMA Band II/V: All up bits LTE FDD 2/4/5/12/13:max power LTE TDD 66:max power		
Test Modulation:	(GSM) GMSK; (WCDMA) QPSK, 16QAM; (LTE) QPSK, 16QAM, 64QAM; (Wi-Fi 2.4G) DSSS, OFDM (Wi-Fi 5G) OFDM		
Operating Frequency Range(s):	Band	Tx (MHz)	Rx (MHz)
	GSM 850	824 ~ 849	869 ~ 894
	GSM 1900	1850 ~ 1910	1930 ~ 1990
	WCDMA Band II	1850 ~ 1910	1930 ~ 1990
	WCDMA Band V	824 ~ 849	869 ~ 894
	LTE Band 2	1850 ~ 1910	1930 ~ 1990
	LTE Band 4	1710 ~ 1755	2110 ~ 2155
	LTE Band 5	824 ~ 849	869 ~ 894

	LTE Band 12	699 ~ 716	729 ~ 746
	LTE Band 13	777 ~ 787	746 ~ 756
	LTE Band 66	1710 ~ 1780	2110 ~ 2180
	Wi-Fi 2.4G	2412 ~ 2462	2412 ~ 2462
	Wi-Fi 5G(U-NII-1)	5150 ~ 5250	5150 ~ 5250
	Wi-Fi 5G(U-NII-2A)	5250 ~ 5350	5250 ~ 5350
	Wi-Fi 5G(U-NII-2C)	5470 ~ 5725	5470 ~ 5725
	Wi-Fi 5G(U-NII-3)	5725 ~ 5850	5725 ~ 5850
Accessory Equipment			
Battery 1	Manufacturer: Gaoyuan Model: ZN06F01/426385PL		
Battery 2	Manufacturer: Highpower Model: B0140A		
Note: The EUT is sent from the applicant to TA and the information of the EUT is declared by the applicant.			

Difference Configuration Statement					
Component		First Supply		Second Supply	
		Supplier	Spec	Supplier	Spec
PCBA	3GB LPDDR	Longsys	3GB	biwin	3GB
	64GB EMMC	Longsys	64GB	biwin	64GB
LCM	LCD	TCL	LCD a-Si TFT; 720*1612	lceptron	LCD a-Si TFT; 720*1612
Front camera	Camera	Union Image	5M; FF	Imaging	5M; FF
CAM	Camera	Union Image	13 AF	Sunwin	13 AF
	Camera	SEGA	2M	Imaging	2M
Acoustic	Vibrator	KunWang	0830	HONGZHIFA	0830
	FPC	XINYE	Speaker FPC: 32.1*11.46*0.15	Lat	Speaker FPC: 32.1*11.46*0.15
LED		Runlite	White LED; 500mA; 1500mA	latticepower	White LED; 500mA; 1500mA
Battery		gaoyuan	4000mAh; 3.87V; 4.45V	highpower	4000mAh; 3.87V; 4.45V
Antenna		Haitong	Omni-directional, Linear, antenna shrapnel	Kexinhuachen g	Omni-directional, Linear, antenna shrapnel
MIC		Gettop	L2.75xW1.85xH0.9 mm	goertek	L2.75xW1.85xH0.9 mm
Data cable		Saibao	5V2A	TorchWay	5V2A

Air-Interface	Band (MHz)	Type	ANSI C63.19 tested	Simultaneous Transmissions	Voice over Digital Transport OTT Capability	Name of Voice Service	Power Reduction
GSM	850	VO	No	Yes BT or Wi-Fi	N/A	CMRS Voice	N/A
	1900						
	GPRS/EDGE	VD	Yes	Yes	Google Duo	No	
WCDMA	Band II	VO	No	Yes BT or Wi-Fi	N/A	CMRS Voice	N/A
	Band V						
	HSPA	VD	Yes	Yes	Google Duo	No	
LTE	Band 2	VD	Yes	Yes BT or Wi-Fi	Yes	VoLTE Google Duo	No
	Band 4						
	Band 5						
	Band 12						
	Band 13						
	Band 66						
Wi-Fi	2450	VD	Yes	Yes GSM, WCDMA, LTE,	Yes	VoWi-Fi Google Duo	No
	U-NII-1						
	U-NII-2A						
	U-NII-2C						
	U-NII-3						

VO= legacy Cellular Voice Service from Table 7.1 in 7.4.2.1 of ANSI C63.19-2011

VD= IP voice service over digital transport.

DT= Digital Transport only (no voice)

#: Ref Lev in accordance with 7.4.2.1 of ANSI C63.19-2011

##: Ref Lev in accordance with the July 2012 VoLTE interpretation.

4 Test Specification and Operational Conditions

4.1 Test Specification

The tests documented in this report were performed in accordance with the following:

FCC CFR47 Part 20.19

ANSI C63.19-2019

KDB 285076 D01 HAC Guidance v06r04

KDB 285076 D02 T-Coil testing for CMRS IP v04

5 Test Information

5.1 Operational Conditions during Test

5.1.1 General Description of Test Procedures

The following steps summarize the basic test flow for determining desired ABM signal and undesired ABM field. These steps assume that a sine wave or narrowband 1/3 octave signal can be used for the measurement of desired ABM signal level. An alternative procedure, yielding equivalent results, using a broadband excitation is described in ANSI C63.19-2019 per 6.5.

- a) A validation of the test setup and instrumentation shall be performed. This may be done using a TMFS or Helmholtz Coil. Measure the emissions and confirm that they are within tolerance of the expected values.
- b) Confirm that equipment that requires calibration has been calibrated, and that the noise level meets the requirements given in ANSI C63.19-2019 per 6.3.2.
- c) Position the WD in the test setup and connect the WD RF connector to a base station simulator or a non-radiating load (if necessary to control RF interference in the measurement equipment).
- d) The drive level to the WD is set such that the reference input level specified is input to the base station simulator (or manufacturer's test mode equivalent) in the 1 kHz, 1/3 octave band. This drive level shall be used for the T-Coil signal test (desired ABM signal) at $f = 1$ kHz. Either a sine wave at 1025 Hz, or a voice-like signal, band-limited to the 1 kHz 1/3 octave, as specified in ANSI C63.19-2019 per 6.4.3, shall be used for the reference audio signal. If interference is found at 1025 Hz an alternative nearby reference audio signal frequency may be used.³⁵ The same drive level will be used for the desired ABM signal frequency response measurements at each 1/3 octave band center frequency. The WD volume control may be set at any level up to maximum, provided that a signal at any frequency at maximum modulation would not result in clipping or signal overload.
- e) At each measurement location over the measurement area and in the transverse orientation, measure and record the desired 1 kHz T-Coil magnetic signal (desired ABM signal) as described in Step c).
- f) At or near a location representing a maximum in the just-measured desired ABM signal, measure and record the desired T-Coil magnetic signals (desired ABM signal at f_i) as described in ANSI C63.19-2019 per 6.4.5.2 in each individual ISO 266:1975 R10 standard 1/3 octave band. The desired audio band input frequency (f_i) shall be centered in each 1/3 octave band maintaining the same drive level as determined in Step c), and the reading taken for that band.³⁶ Equivalent methods of determining the frequency response may also be employed, such as fast Fourier transform (FFT) analysis using noise excitation or input – output comparison using simulated speech. The full-band integrated or half-band integrated probe output, as described in D.9, may be used, as long as the appropriate calibration curve is applied to the measured result, so as to yield an accurate measurement of the field magnitude. (The resulting measurement shall be an accurate measurement in dB(A/m).) Compare the frequency response found to the requirements of ANSI C63.19-2019 per 6.6.3.
- g) At the same locations measured in Step d), measure and record the undesired broadband audio magnetic signal (undesired ABM field) with no audio signal applied (or digital zero applied, if

appropriate) using the specified spectral weighting, the half-band integrator followed by the temporal weighting.

h) Calculate and record the location and number of the measurement points that satisfy both the minimum desired ABM signal level and the maximum undesired ABM field level specified in ANSI C63.19-2019 per 6.6.2. Compare this to the requirements in ANSI C63.19-2019 per 6.6.4 and record the result.

i) Calculate and record the location and number of the measurement points that satisfy the maximum undesired ABM field level and distribution requirements specified in ANSI C63.19-2019 per 6.6.4.

5.2 T-Coil Measurements System Configuration

5.2.1 T-coil Measurement Set-up for OTT

These measurements are performed using the DASY8 automated dosimetric assessment system. It is made by Schmid & Partner Engineering AG (SPEAG) in Zurich, Switzerland. It consists of high precision robotics system (Stäubli), robot controller, Intel Core computer, near-field probe, probe alignment sensor. The robot is a six-axis industrial robot performing precise movements. Cell controller systems contain the power supply, robot controller, teach pendant (Joystick) and remote control, and are used to drive the robot motors. The Stäubli Robot is connected to the cell controller to allow software manipulation of the robot. A data acquisition electronic (DAE) circuit performs the signal amplification; signal multiplexing, AD-conversion, offset measurements, mechanical surface detection, collision detection, etc. is connected to the Electro-optical coupler (EOC). The EOC performs the conversion from the optical into digital electric signal of the DAE and transfers data to the PC plug-in card.

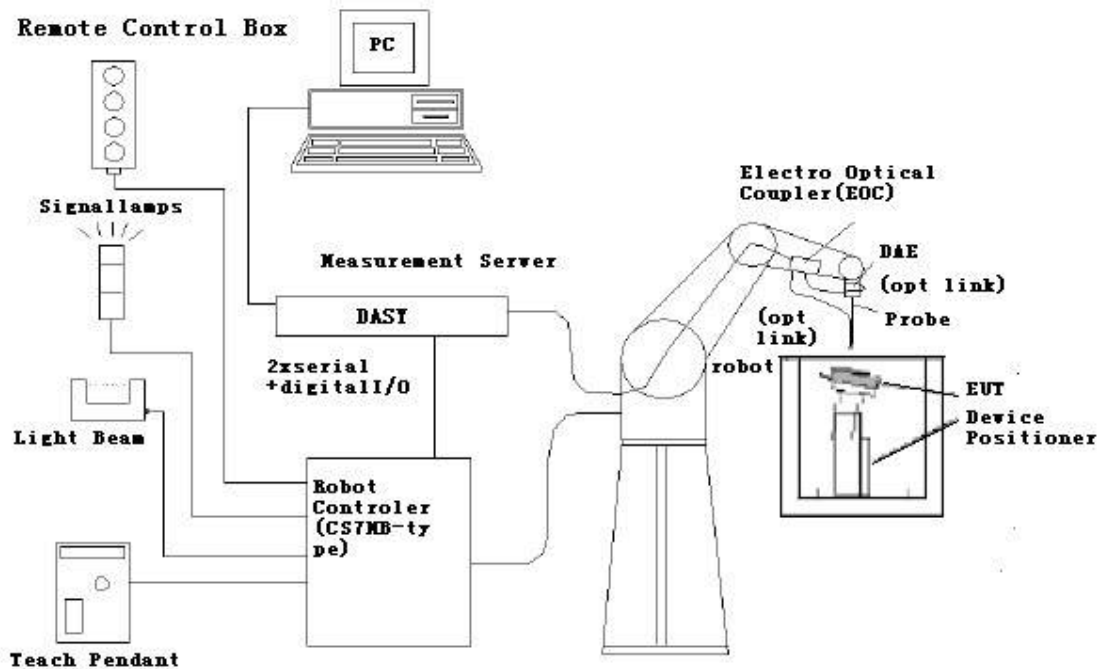

Figure 1 T-Coil Test Measurement Set-up

The DAE4 consists of a highly sensitive electrometer-grade preamplifier with auto-zeroing, a channel and gain-switching multiplexer, a fast 16 bit AD-converter and a command decoder and control logic unit. Transmission to the PC-card is accomplished through an optical downlink for data and status information and an optical uplink for commands and clock lines. The mechanical probe mounting device includes two different sensor systems for frontal and sidewise probe contacts. They are also used for mechanical surface detection and probe collision detection. The robot uses its own controller with a built in VME-bus computer.



Figure 2 T-Coil Test Measurement Set-up

5.2.2 AM1D Probe

The AM1D probe is an active probe with a single sensor. It is fully RF-shielded and has a rounded tip 6mm in diameter incorporating a pickup coil with its center offset 3mm from the tip and the sides. The symmetric signal preamplifier in the probe is fed via the shielded symmetric output cable from the AMMI with a 48V “phantom” voltage supply. The 7-pin connector on the back in the axis of the probe does not carry any signals. It is mounted to the DAE for the correct orientation of the sensor. If the probe axis is tilted 54.7 degree from the vertical, the sensor is approximately vertical when the signal connector is at the underside of the probe (cable hanging downwards).

Specification

frequency range	0.1 - 20 kHz (RF sensitivity <-100 dB, fully RF shielded)
sensitivity	<-50 dB A/m @ 1 kHz
pre-amplifier	40 dB, symmetric
dimensions	tip diameter / length: 6 / 290 mm, sensor according to ANSI-C63.19



Figure 3 AM1D Probe

5.2.3 Audio Magnetic Measurement Instrument (AMMI)

The Audio Magnetic Measuring Instrument (AMMI) is a desktop 19-inch unit containing a sampling unit, a waveform generator for test and calibration signals, and a USB interface.



Figure 4 AMMI front panel

Port description:

Audio Out	BNC, audio signal to the base station simulator, for >500Ohm load
Coil Out	BNC, test and calibration signal to the AMCC (top connector), for 50Ohm load
Coil In	XLR, monitor signal from the AMCC BNO connector, 600 Ohm
Probe In	XLR, probe signal and phantom supply to the probe Lemo connector



Figure 5 AMMI rear side

Sampling rate	48 kHz / 24 bit
Dynamic range	85 dB
Test signal generation	User selectable and predefined (vis PC)
Calibration	Auto-calibration / full system calibration using AMCC with monitor output
Dimensions	482 x 65 x 270 mm

5.2.4 Helmholtz Calibration Coil (AMCC)

The Audio Magnetic Calibration coil is a Helmholtz Coil designed for calibration of the AM1D probe. The two horizontal coils generate a homogeneous magnetic field in the z direction. The DC input resistance is adjusted by a series resistor to approximately 50Ohm, and a shunt resistor of 10Ohm permits monitoring the current with a scale of 1:10

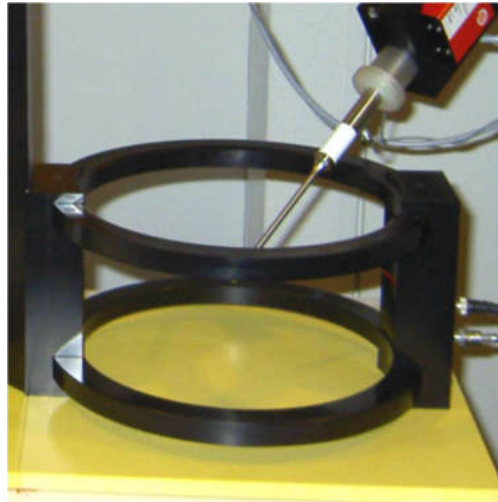

Figure 6 AMCC

Port description:

Signal	Connector	Resistance
Coil In	BNC	Typically 50Ohm
Coil Monitor	BNO	10Ohm ± 1% (100mV corresponding to 1 A/m)

Specification:

Dimensions	370 x 370 x 196 mm, according to ANSI-C63.19
-------------------	--

5.2.5 Test Arch Phantom & Phone Positioner

The Test Arch phantom should be positioned horizontally on a stable surface. Reference markings on the Phantom allow the complete setup of all predefined phantom positions and measurement grids by manually teaching three points in the robot. It enables easy and well defined positioning of the phone and validation dipoles as well as simple teaching of the robot (Dimensions: 370 x 370 x 370 mm).

The Device reference point is set for the EUT at 6.3 mm, the Grid reference point is on the upper surface at the origin of the coordinates, and the “user point \Height Check 0.5 mm” is 0.5mm above the center, allowing verification of the gap of 0.5mm while the probe is positioned there.

The Phone Positioner supports accurate and reliable positioning of any phone with effect on near field $\pm 0.5\text{ dB}$.



Figure 7 T-coil Phantom & Device Holder

5.3 T-Coil measurement points and reference plane

The following figure illustrates the standard probe orientations. Position 1 is the perpendicular orientation of the probe coil; orientation 2 is the transverse orientation. The space between the measurement positions is not fixed. It is recommended that a scan of the WD be performed for each probe coil orientation and that the maximum level recorded be used as the reading for that orientation of the probe coil.

- 1) The reference plane is the planar area that contains the highest point in the area of the phone that normally rests against the user's ear. It is parallel to the centerline of the receiver area of the phone and is defined by the points of the receiver-end of the EUT handset, which, in normal handset use, rest against the ear.
- 2) The measurement plane is parallel to, and 10 mm in front of, the reference plane.
- 3) The reference axis is normal to the reference plane and passes through the center of the receiver speaker section (or the center of the hole array); or may be centered on a secondary inductive source. The actual location of the measurement point shall be noted in the test report as the measurement reference point.
- 4) The measurement points may be located where the axial and radial field intensity measurements are optimum with regard to the requirements. However, the measurement points should be near the acoustic output of the EUT and shall be located in the same half of the phone as the EUT receiver. In a EUT handset with a centered receiver and a circularly symmetrical magnetic field, the measurement axis and the reference axis would coincide.

- 5) The relative spacing of each measurement orientation is not fixed. The axial and two radial orientations should be chosen to select the optimal position.
- 6) The measurement point for the axial position is located 10 mm from the reference plane on the measurement axis.
- 7) The actual location of the measurement point shall be noted in test reports and designated as the measurement reference point.

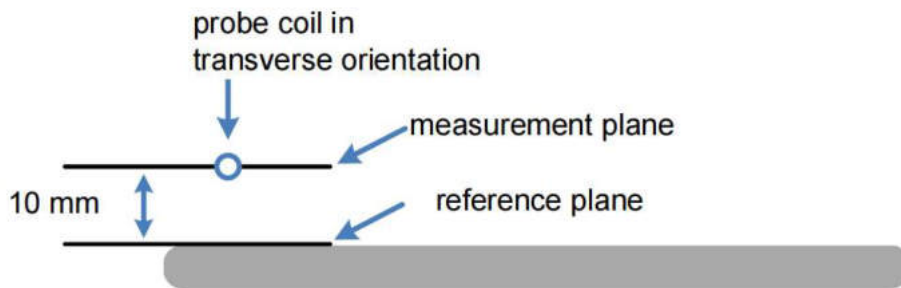
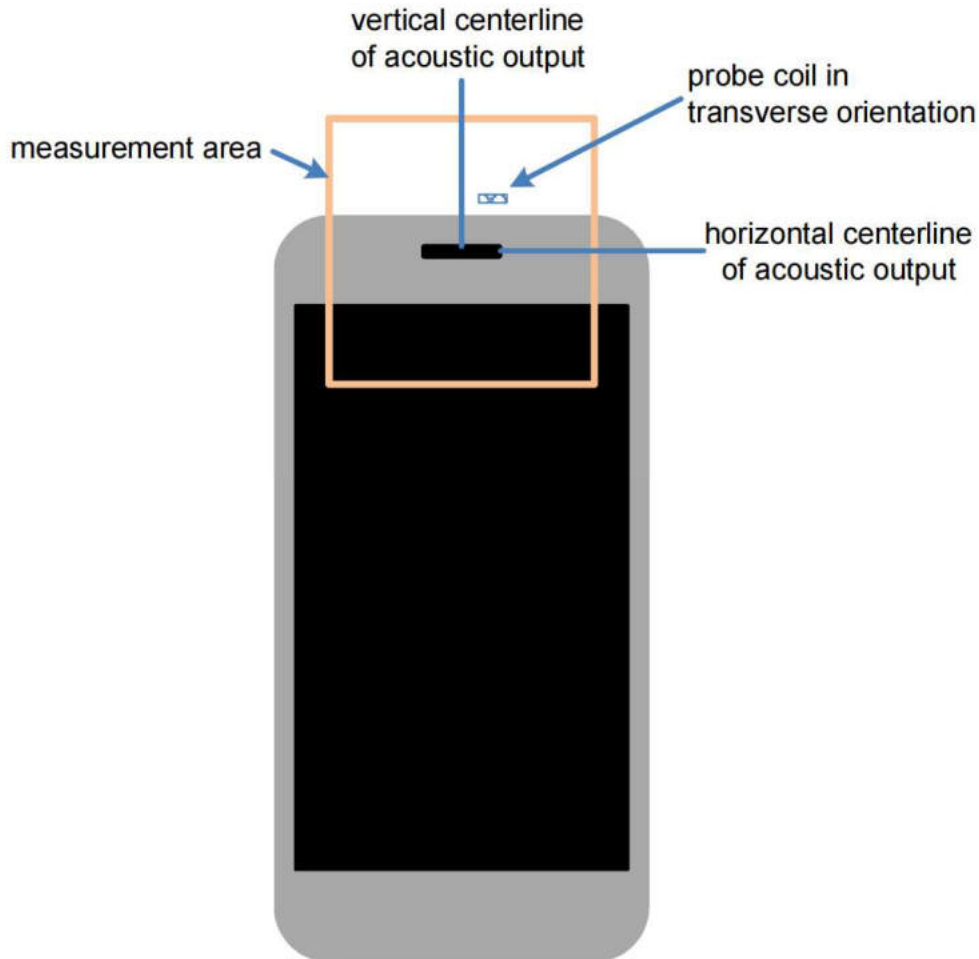

Figure 8 Axis and planes for EUT audio frequency magnetic field measurements

6 T-Coil Performance Requirements

In order to comply with the requirements for T-Coil use, a WD's tested operating modes shall simultaneously meet the requirements for minimum desired ABM signal level and maximum undesired ABM field contained in this subclause at the minimum specified number of scanned locations.

6.1 T-Coil coupling qualifying field strengths

When measured as specified in this standard, there are two groups of qualifying measurement points:

Primary group: A qualifying measurement point shall have its T-Coil signal, desired ABM signal >-18 dB(A/m) at 1 Hz, in a 1/3 octave band filter. These measurements shall be made with the WD operating at a reference input level as specified in ANSI C63.19-2019 Table 6.1. Simultaneously, the qualifying measurement point shall have its weighted magnetic noise, undesired ABM field <-38 dB(A/m).

Secondary group: A qualifying measurement point shall have its weighted magnetic noise, undesired ABM field <-38 dB(A/m). This group inherently includes all the members of the primary group.

These levels are designed to be compatible with hearing aids that produce the same acoustic output level for either an acoustic input level of 65 dB SPL or a magnetic input level of -25 dB(A/m) (56.2 mA/m) at either 1.0 kHz or 1.6 kHz. The hearing aid operational measurements are performed per ANSI S3.22-2014.

6.2 Frequency response

The frequency response of the magnetic field, measured in 1/3 octave bands, shall follow the response curve specified in this subclause, over the frequency range 300 Hz to 3 kHz.

Figure 9 and Figure 10 provide the boundaries for the specified frequency. These response curves are for true field strength measurements of the T-Coil signal. Thus the 6 dB/octave probe response has been corrected from the raw readings.

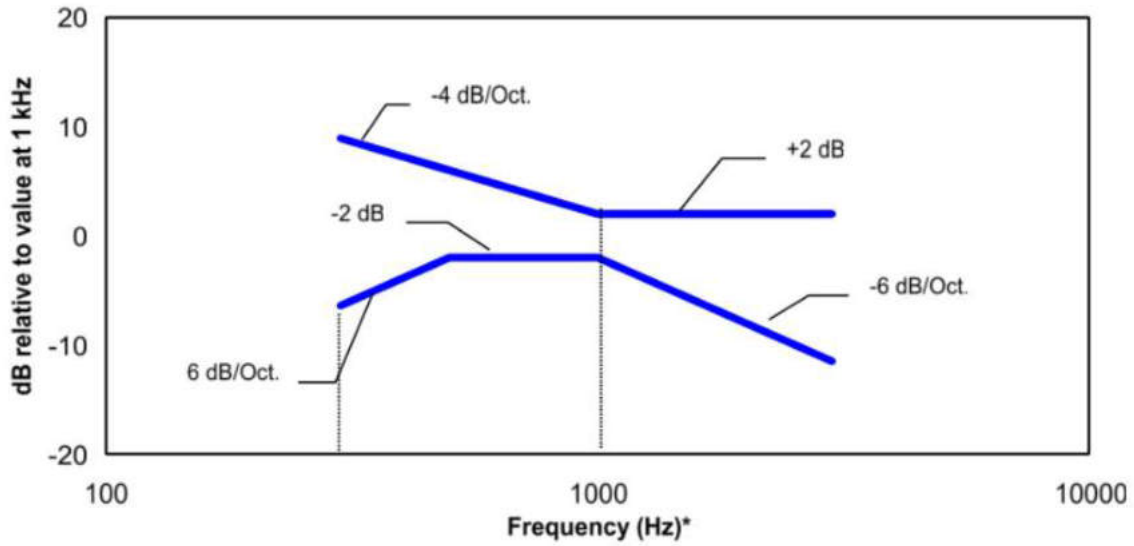

NOTE—Frequency response is between 300 Hz and 3 kHz.

Figure 9 Magnetic field frequency response for WDs with a maximum field ≤ -15 dB (A/m) at 1 kHz

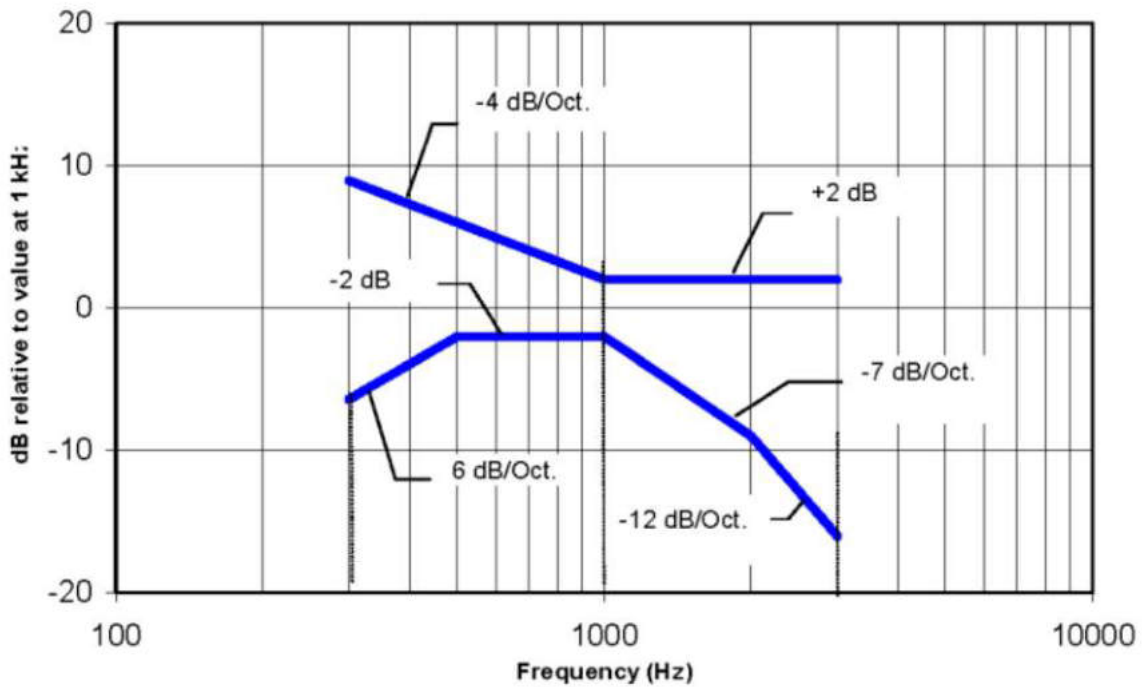

NOTE—Frequency response is between 300 Hz and 3000 Hz.

Figure 10 Magnetic field frequency response for WDs with a maximum field that exceeds -15 dB (A/m) at 1 kHz

6.3 Desired ABM signal, undesired ABM field qualification requirements

1. The Google Duo applicable are pre-installed on this device. So all air interfaces via a date

connection with VOIP need to be tested per KDB 285076 D02.

2. The test setup used for OTT VOIP call is : the DUT connect to the CMW500 and via the data application unit on CMW500 connection to the foreign internet, the Auxiliary DUT is connected to the Wi-Fi access point. Test channel/modulation/frequency bands/data rate is configured by CMW500 for DUT.

6.3.1 Non-2G GSM operating modes

The goal of this requirement is to ensure an adequate area where desired ABM signal is sufficiently strong to be heard clearly and a larger area where undesired ABM field is sufficiently low as to avoid undue annoyance. Qualifying measurement points shall fulfill the requirements of 6.6.2: both the primary and secondary group requirements shall be met:

- The primary group shall include at least 75 measurement points.
- The secondary group shall include at least 300 contiguous measurement points.

Additionally, to avoid an oddly shaped area of low noise, the secondary group shall include at least one longitudinal column of at least 10 contiguous qualifying points and at least one transverse row containing at least 15 contiguous qualifying points.

Figure 6.6 is an example of a qualifying scan. The total number of primary group qualifying measurement points is 161, which is ≥ 75 . The total number of secondary group qualifying points is 536, which is ≥ 300 .

The secondary group has a longitudinal column of 26, which is >10 , and a transverse row also of 26 contiguous points which is >15 .

6.3.2 2G GSM operating modes

If the 2G GSM operating mode(s) are selected for qualification, the qualifying measurement points shall fulfil the requirements of 6.6.2; both the primary and secondary group requirements shall be met:

- The primary group shall include at least 25 measurement points.
- The secondary group shall include at least 125 contiguous measurement points.

7 T-Coil testing for OTT

This device supports VoIP via a preinstalled application that uses the Google Duo service, using OPUS as its only codec. VoIP capabilities require HAC assessment when voice calls are supported over the cellular data connection via preinstalled VoIP applications and the assessment is subject to Pre-Approval Guidance procedures.

The equipment is set up as shown below with a support device used to originate the call using the IP transport. The support device connects to the cloud-based Google Duo service via Wi-Fi access point and router, or RJ45. The DUT connects to the VoIP service via a cellular/unlicensed air interface to the call box and an Ethernet connection from call box to Internet. The various codec bit rate and air interface configurations are evaluated to determine the worst-case configuration

Test Setup configuration for OTT calls

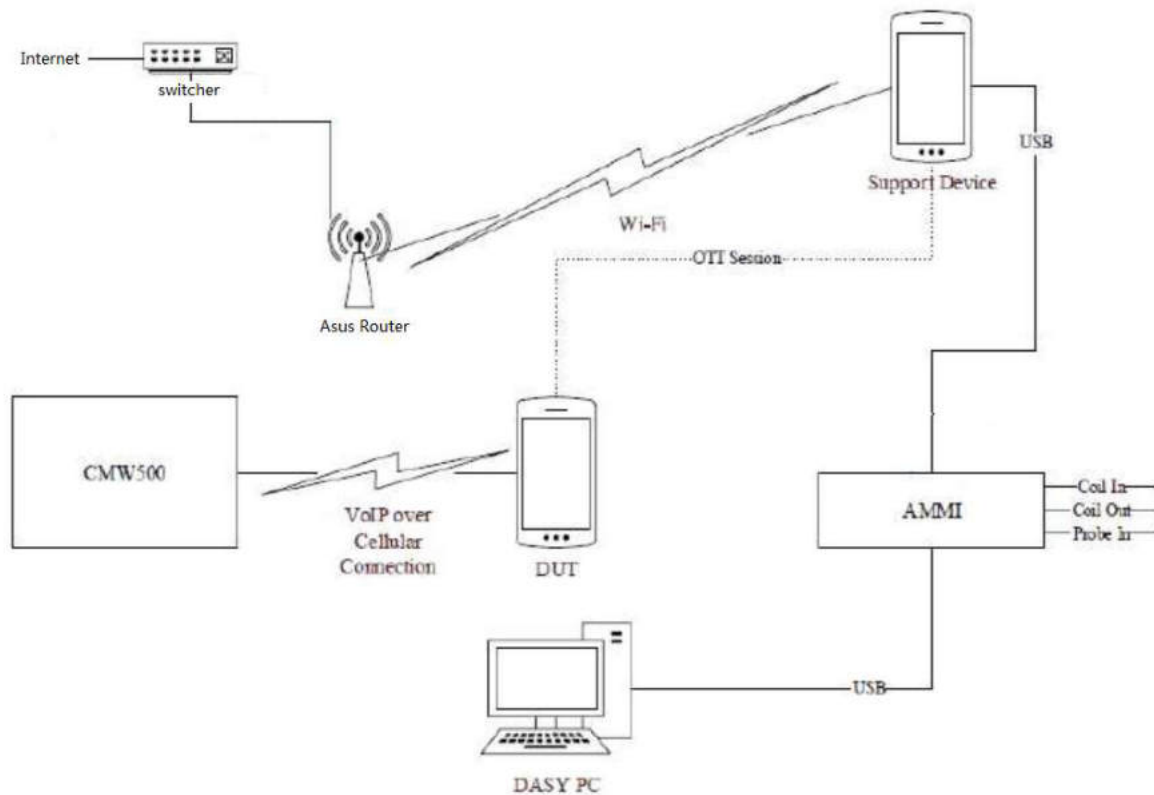

For the OTT call, the calibrated audio card within the CMW500 cannot be used so the AMMI is connected to an external Digital-Analog Converter (DAC) and the DAC is connected to the Support Device via USB. The test signal is sent from the DASY PC to the AMMI, from the AMMI to the DAC, from the DAC to the Support Device, and, via the VoIP call, to the DUT.

As this test set up uses an external DAC between the AMMI's audio output and support device, the appropriate gain factor for the OTT call needs be determined. This is done by connecting the DAC between the AMMI Audio output and Coil input as shown below.

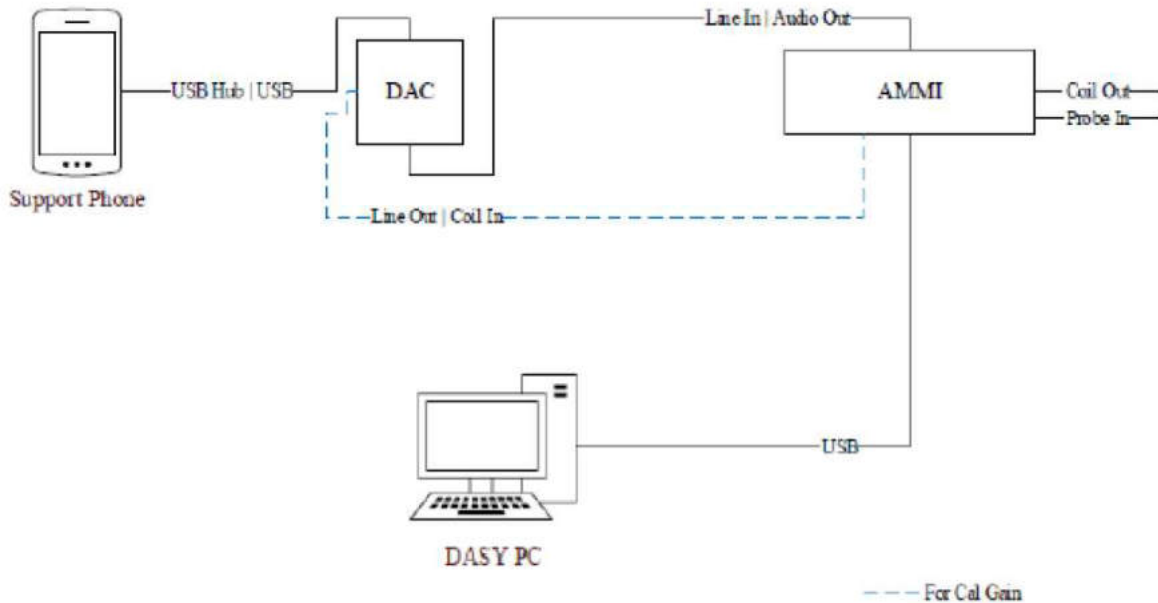

Using the metering function on the DAC, the DAC gain is adjusted until the volume reaches 0 dBFS (3.14 dBm0 based on TIA/EIA 810-A). SPEAG's "TN-LK-05042018-C-T-Coil_Levels" document (ANNEX E) steps E through H are then followed to determine the adjusted gain values so that the reference level is set to 23.14dB below full scale, i.e. at -20dBm0. A verification of the DAC's output is performed prior to testing.

According to 285076 D02 T-Coil testing:

Reporting results involves a two-step process: (1) Codec Investigation to determine the worstcase codec for each voice service, and (2) Air Interface Investigation. Using the worst-case codec for a voice service, a range of channels and bands shall be tested.

- a) Codec Investigation: For a voice service/air interface, investigate the variations of codec configurations (WB, NB bit rate) and document the parameters (ABM1, ABM2, S+N/N, frequency response) for that voice service. It is only necessary to document this for one channel/band. However, the tester should spot check other combinations to ensure that the channel/band used represents the worst-case codec.
- b) Air Interface Investigation: Use the worst-case codec test and document a limited set of bands/channels/bandwidth. Observe the effect of changing the band and bandwidth to ensure that there are no unexpected variations. Using the knowledge of the observed variations, it is necessary to report only a set band/channel/bandwidth for each orientation for a voice service/air interface. Consult with the manufacturer for any abnormal results.

Codec Investigation Results:

Codec Investigation - OTT VoIP (EDGE)						
Codec Setting	75kbps	35kbps	6kbps	Orientation	Band	Channel
Signal (dBA/m)	-0.79	-1.22	-5.92	Signal	GSM 850	190
Noise (dBA/m)	-42.26	-42.48	-43.14			
Frequency Response	PASS	PASS	PASS			
Signal Quality (dB)	41.47	41.26	37.22			

Codec Investigation - OTT VoIP (HSPA)						
Codec Setting	75kbps	35kbps	6kbps	Orientation	Band	Channel
Signal (dBA/m)	-3.8	-4.13	-5.02	Signal	WCDMA Band 2	9400
Noise (dBA/m)	-43.14	-41.79	-42.08			
Frequency Response	PASS	PASS	PASS			
Signal Quality (dB)	39.34	37.66	37.06			

Codec Investigation - OTT VoIP (LTE)						
Codec Setting	75kbps	35kbps	6kbps	Orientation	Band	Channel
Signal \geq -18 (dBA/m)	-3.14	-3.82	-6.76	Signal	LTE Band 2	18900
Noise (dBA/m)	-40.47	-40.52	-40.42			
Frequency Response	PASS	PASS	PASS			
Signal Quality (dB)	37.33	36.7	33.66			

Codec Investigation - OTT VoIP (Wi-Fi)							
Codec Setting	75kbps	35kbps	6kbps	Orientation	Band	Standard	Channel
Signal \geq -18 (dBA/m)	-4.33	-4.73	-5.8	Signal	2.4GHz	802.11b	6
Noise (dBA/m)	-43.14	-42.15	-42.51				
Frequency Response	PASS	PASS	PASS				
Signal Quality (dB)	38.81	37.42	36.71				
Signal \geq -18 (dBA/m)	-4.58	-4.52	-6	Signal	5GHz	802.11a	36
Noise (dBA/m)	-40.13	-40.68	-40.04				
Frequency Response	PASS	PASS	PASS				
Signal Quality (dB)	35.55	36.16	34.04				

8 Air Interface Investigation Test Results

For GSM

Air Interface Investigation							
Mode	Channel /Frequency (MHz)	Signal (dBA/m)	Noise (dBA/m)	Freq. Resp. Diff (dB)	Primary Group Contiguous Point Count (>25)	Secondary Group Point Count (>125)	ABM SNR (dB)
GSM 850	128/824.2	-6.05	-43.65	0.36	197	676	37.60
Google Duo	190/836.6	-5.92	-43.14	0.66	198	676	37.22
6kbps	251/848.8	-6.22	-44.33	0.68	204	676	38.11

Band	Channel /Frequency (MHz)	Signal (dBA/m)	Noise (dBA/m)	Freq. Resp. Diff (dB)	Primary Group Contiguous Point Count (>25)	Secondary Group Point Count (>125)	ABM SNR (dB)	Plot No.
GSM 850 Google Duo 6kbps	190/836.6	-5.92	-43.14	0.66	198	676	37.22	1
GSM 850 Google Duo 6kbps (Second Supply)	190/836.6	-3.99	-42.74	0.56	232	676	38.75	2
GSM 1900 Google Duo 6kbps	661/1880	-5.03	-43.99	1.25	198	676	38.96	3

Note:

1. The LCD backlight is turn off and volume is adjusted to maximum level during T-Coil testing.
2. Signal strength measurement scan plots are presented in Annex B.

For WCDMA

Mode	Channel /Frequency (MHz)	Signal \geq -18 (dBA/m)	Noise \leq -38 (dBA/m)	Freq. Resp. Diff (dB)	Primary Group Contiguous Point Count (>75)	Secondary Group Point Count (>300)	ABM SNR (dB)
WCDMA B2	9262/1852.4	-5.43	-42.89	1.12	195	676	37.46
Google Duo	9400/1880	-5.02	-42.08	1.03	234	676	37.06
6kbps	9538/1907.6	-6.95	-42.24	0.66	190	676	35.29

Band	Channel /Frequency (MHz)	Signal (dBA/m)	Noise (dBA/m)	Freq. Resp. Diff (dB)	Primary Group Contiguous Point Count (>75)	Secondary Group Point Count (>300)	ABM SNR (dB)	Plot No.
WCDMA B2 Google Duo 6kbps	9538/1907.6	-8.84	-42.24	1.40	149	676	33.4	4
WCDMA B2 Google Duo 6kbps (Second Supply)	9538/1907.6	-1.72	-42.83	0.78	293	676	41.11	5
WCDMA B5 Google Duo 6kbps	4233/846.6	-8.63	-42.19	0.51	150	676	33.56	6

Note:

1. The LCD backlight is turn off and volume is adjusted to maximum level during T-Coil testing.
2. Signal strength measurement scan plots are presented in Annex B.

For LTE

Air Interface Investigation									
Mode	Channel	Bandwidth (MHz)	Orientation	Signal (dBA/m)	Noise (dBA/m)	Frequency Response Variation (dB)	Primary Group Contiguous Point Count(>75)	Secondary Group Point Count (>300)	ABM SNR (dB)
LTE FDD B2 Google Duo 6kbps	18900	20	Signal	-6.76	-40.42	1.83	196	676	33.66
		15		-6.11	-40.96	1.25	188	676	34.85
		10		-6.59	-40.62	1.36	200	676	34.03
		5		-5.14	-39.73	1.11	221	676	34.59
		3		-6.28	-40.53	1.46	199	676	34.25
		1.4		-6.78	-40.62	1.50	199	676	33.84

Mode	Channel	Bandwidth (MHz)	Modulation	RB Size	RB Offset	Signal (dBA/m)	Noise (dBA/m)	Frequency Response Variation (dB)	Primary Group Contiguous Point Count (>75)	Secondary Group Point Count (>300)	ABM SNR (dB)
LTE FDD B2 Google Duo 6kbps	18900	20	QPSK	1	0	-6.76	-40.42	1.83	196	676	33.66
				1	50	-6.23	-41.96	1.25	191	676	35.73
				1	99	-5.73	-42.19	1.33	198	676	36.46
				50	0	-6.32	-41.86	0.96	196	676	35.54
				50	25	-6.44	-42.07	0.85	202	676	35.63
				50	50	-6.51	-42.08	1.18	196	676	35.57
			16QAM	100	0	-5.95	-42.82	1.36	181	676	36.87
				1	0	-6.05	-42.68	0.96	199	676	36.63
				1	50	-5.86	-42.69	0.99	181	676	36.83
				1	99	-6.09	-40.47	1.82	180	676	34.38
				50	0	-6.36	-41.08	1.74	192	676	34.72
				50	25	-5.76	-41.2	1.63	190	676	35.44
				50	50	-6.08	-41.19	1.55	196	676	35.11
				100	0	-6.45	-40.38	1.33	185	676	33.93

Mode	Channel /Frequency (MHz)	Signal (dBA/m)	Noise (dBA/m)	Freq. Resp. Diff (dB)	Primary Group Contiguous Point Count (>75)	Secondary Group Point Count (>300)	ABM SNR (dB)
LTE FDD B2 Google Duo 6kbps	18700/1860 (QPSK_20M_1RB_0offset)	-6.07	-41.15	1.54	191	676	35.08
	18900/1880 (QPSK_20M_1RB_0offset)	-6.76	-40.42	1.83	196	676	33.66
	19100/1900 (QPSK_20M_1RB_0offset)	-6.07	-41.96	1.65	192	676	35.89
LTE FDD B2 Google Duo 6kbps	18900/1880 (16QAM_20M_10R_B_0offset)	-6.45	-40.38	1.33	185	676	33.93

Band	Channel /Frequency (MHz)	Signal (dBA/m)	Noise (dBA/m)	Freq. Resp. Diff (dB)	Primary Group Contiguous Point Count (>75)	Secondary Group Point Count (>300)	ABM SNR (dB)	Plot No.
LTE FDD B2 Google Duo 6kbps	18900/1880 (QPSK_20M_Full RB_0offset)	-6.76	-40.42	1.83	196	676	33.66	7
LTE FDD B5 Google Duo 6kbps	20525/836.5 (QPSK_10M_Full RB_0offset)	-6.24	-39.63	1.15	170	676	33.39	8
LTE FDD B12 Google Duo 6kbps	23095/707.5 (QPSK_10M_Full RB_0offset)	-8.76	-40.99	1.51	149	676	32.23	9
LTE FDD B12 Google Duo 6kbps (Second Supply)	23095/707.5 (QPSK_10M_Full RB_0offset)	-5.25	-39.60	1.93	201	676	34.35	10
LTE FDD B13 Google Duo 6kbps	23230/782 (QPSK_10M_Full RB_0offset)	-9.18	-44.10	1.21	144	676	34.92	11
LTE FDD B66 Google Duo 6kbps	132322/1745 (QPSK_20M_Full RB_0offset)	-8.82	-41.45	1.11	146	676	32.63	12

Note: 1. The LCD backlight is turn off and volume is adjusted to maximum level during T-Coil testing.

2. Signal strength measurement scan plots are presented in Annex B.

For Wi-Fi

802.11b Radio configuration investigation							
Mode	Channel	Data Rate [Mbps]	Signal \geq -18 (dBA/m)	Noise \leq -38 (dBA/m)	Freq. Resp. Diff (dB)	Primary Group Contiguous Point Count (>75)	Secondary Group Point Count (>300)
802.11b	6	1	-5.8	-42.51	1.38	201	676
802.11b	6	11	-4.98	-42.53	0.81	222	676
802.11g Radio configuration investigation							
Mode	Channel	Data Rate [Mbps]	Signal \geq -18 (dBA/m)	Noise \leq -38 (dBA/m)	Freq. Resp. Diff (dB)	Primary Group Contiguous Point Count (>75)	Secondary Group Point Count (>300)
802.11g	6	6	-5.28	-43.12	0.5	221	676
802.11g	6	54	-5.94	-44.11	1.30	215	676
802.11n HT20 Radio configuration investigation							
Mode	Channel	Data Rate [Mbps]	Signal \geq -18 (dBA/m)	Noise \leq -38 (dBA/m)	Freq. Resp. Diff (dB)	Primary Group Contiguous Point Count (>75)	Secondary Group Point Count (>300)
802.11n HT20	6	MCS0	-5.17	-42.73	0.63	224	676
802.11n HT20	6	MCS7	-5.47	-42.33	0.15	196	676
802.11n HT40 Radio configuration investigation							
Mode	Channel	Data Rate [Mbps]	Signal \geq -18 (dBA/m)	Noise \leq -38 (dBA/m)	Freq. Resp. Diff (dB)	Primary Group Contiguous Point Count (>75)	Secondary Group Point Count (>300)
802.11n HT40	6	MCS0	-5.58	-42.55	1.17	198	676
802.11n HT40	6	MCS7	-6.10	-43.22	0.64	221	676
802.11a Radio configuration investigation							
Mode	Channel	Data Rate [Mbps]	Signal \geq -18 (dBA/m)	Noise \leq -38 (dBA/m)	Freq. Resp. Diff (dB)	Primary Group Contiguous Point Count (>75)	Secondary Group Point Count (>300)
802.11a	36	6	-6	-40.04	0.18	206	676
802.11a	36	54	-4.01	-41.26	0.46	239	676
802.11ac Radio configuration investigation							
Mode	Channel	Data Rate [Mbps]	Signal \geq -18 (dBA/m)	Noise \leq -38 (dBA/m)	Freq. Resp. Diff (dB)	Primary Group Contiguous Point Count (>75)	Secondary Group Point Count (>300)
802.11ac	36	MCS0	-4.35	-42.58	0.88	207	676
802.11ac	36	MCS7	-5.47	-42.33	0.15	196	676

Air Interface Investigation							
Mode	Channel /Frequency (MHz)	Signal \geq -18 (dB A/m)	Noise \leq -38 (dB A/m)	Freq. Resp. Diff (dB)	Primary Group Contiguous Point Count (>75)	Secondary Group Point Count (>300)	ABM SNR (dB)
WIFI2.4G: 802.11b Google Duo 6kbps	6/2437 (BW:20M_Rate:1M)	-5.80	-42.51	1.38	201	676	36.71
WIFI5G: 802.11a Google Duo 6kbps	36/5180 (BW:20M_Rate:6M)	-6.00	-40.04	0.18	206	676	34.04

Band	Channel /Frequency (MHz)	Signal \geq -18 (dB A/m)	Noise \leq -38 (dB A/m)	Freq. Resp. Diff (dB)	Primary Group Contiguous Point Count (>75)	Secondary Group Point Count (>300)	ABM SNR (dB)	Plot No.
WIFI2.4G: 802.11b Google Duo 6kbps	6/2437 (BW:20M_Rate:1M)	-5.80	-42.51	1.38	201	676	36.71	13
WIFI2.4G: 802.11b Google Duo 6kbps (Second Supply)	6/2437 (BW:20M_Rate:1M)	-9.18	-42.31	0.88	141	676	33.13	14
WIFI2.4G: 802.11g Google Duo 6kbps	6/2437 (BW:20M_Rate:6M)	-5.28	-43.12	0.50	221	676	37.84	/
WIFI2.4G: 802.11n Google Duo 6kbps	6/2437 (BW:20M_Rate:MCS7)	-5.47	-42.33	0.15	196	676	36.86	/
WIFI5G: 802.11a Google Duo 6kbps	36/5180 (BW:20M_Rate:6M)	-6.00	-40.04	0.18	206	676	34.04	15
WIFI5G: 802.11a Google Duo 6kbps (Second Supply)	36/5180 (BW:20M_Rate:6M)	-8.18	-43.10	1.17	144	676	34.92	16
WIFI5G: 802.11ac Google Duo 6kbps	36/5180 (BW:20M_Rate:6M)	-3.97	-41.28	0.69	211	676	37.31	/

Note:

1. The LCD backlight is turn off and volume is adjusted to maximum level during T-Coil testing.
2. Signal strength measurement scan plots are presented in Annex B.

9 Measurement Uncertainty

Measurement uncertainty evaluation template for DUT HAC T-Coil test

Error source	Type	Uncertainty Value a_i (%)	Prob. Dist.	k	ABM1 c_i	ABM2 c_i	Std. Unc. ABM1 (\pm %)	Std. Unc. ABM2 (\pm %)	Degree of freedom V_{eff} or ν_i
Probe Sensitivity									
Reference Level	B	3.0	N	1	1	1	3.0	3.0	∞
AMCC Geometry	B	0.4	R	1.732	1	1	0.2	0.2	∞
AMCC Current	B	0.6	R	1.732	1	1	0.3	0.3	∞
Probe Positioning during Calibration	B	0.1	R	1.732	1	1	0.1	0.1	∞
Noise Contribution	B	0.7	R	1.732	0.0143	1	0.0	0.4	∞
Frequency Slope	B	5.9	R	1.732	0.1	1	0.3	3.4	∞
Probe System									
Repeatability / Drift	B	1.0	R	1.732	1	1	0.6	0.6	∞
Linearity / Dynamic Range	B	0.6	R	1.732	1	1	0.3	0.3	∞
Acoustic Noise	B	1.0	R	1.732	0.1	1	0.1	0.6	∞
Probe Angle	B	2.3	R	1.732	1	1	1.3	1.3	∞
Spectral Processing	B	0.9	R	1.732	1	1	0.5	0.5	∞
Integration Time	B	0.6	N	1	1	5	0.6	3.0	∞
Field Distribution	B	0.2	R	1.732	1	1	0.1	0.1	∞
Test Signal									
Ref.Signal Spectral Response	B	0.6	R	1.732	0	1	0.0	0.3	∞
Positioning									
Probe Positioning	B	1.9	R	1.732	1	1	1.1	1.1	∞
Phantom Thickness	B	0.9	R	1.732	1	1	0.5	0.5	∞
EUT Positioning	B	1.9	R	1.732	1	1	1.1	1.1	∞
External Contributions									
RF Interference	B	0.0	R	1.732	1	0.3	0.0	0.0	∞
Test Signal Variation	B	2.0	R	1.732	1	1	1.2	1.2	∞
Combined Std. Uncertainty (ABM Field)							4.0	6.1	
Expanded Std. Uncertainty							8.0	12.2	

10 Main Test Instruments

Name	Manufacturer	Type	Serial Number	Last Cal.	Cal. Due Date
AMMI	SPEAG	SE UMS 010 BB	1112	/	/
Data Acquisition Electronics	SPEAG	DAE4	1291	2023-03-17	2024-03-16
Probe	SPEAG	AM1DV3	3082	2023-02-16	2024-02-15
Wireless Communication Tester	R&S	CMW 500	146734	2023-05-13	2024-05-12
Hygrothermograph	Anymetr	HTC - 1	TA2023A001	2023-05-13	2024-05-12
Software for Test	SPEAG	DASY8	/	/	/

ANNEX A: Test Layout



Picture 1: HAC T-Coil System Layout

ANNEX B: Graph Results

Plot 1 T-Coil GSM 850 T-Coil Signal Test Report

Measurement performed on January 29, 2024 at 20:17

Device Under Test

Manufacturer	Model	Dimensions [mm]	Speaker Position [mm]
		146.2 x 71.8 x 7.5	144.3

Hardware Setup

Probe Name	Probe Calibration Date	DAE Name	DAE Calibration Date
AM1DV3 - 3082	February 16, 2023	DAE4 Sn1291	March 17, 2023

Communication Systems

Band Name	Communication Systems Name	Channel	Frequency [MHz]
GSM 850	GPRS-FDD (TDMA, GMSK)	190	836.6

Grid Settings

Extent X [mm]	Extent Y [mm]	Step X [mm]	Step Y [mm]	Distance [mm]
52.0	52.0	4.0	4.0	10.0

Results

Audio File	Measurement Duration [s]	Gain [dB]	Hmax [dB(A/m)]
48k_voice_1kHz_1s.wav	2.0	-12.37	-5.92

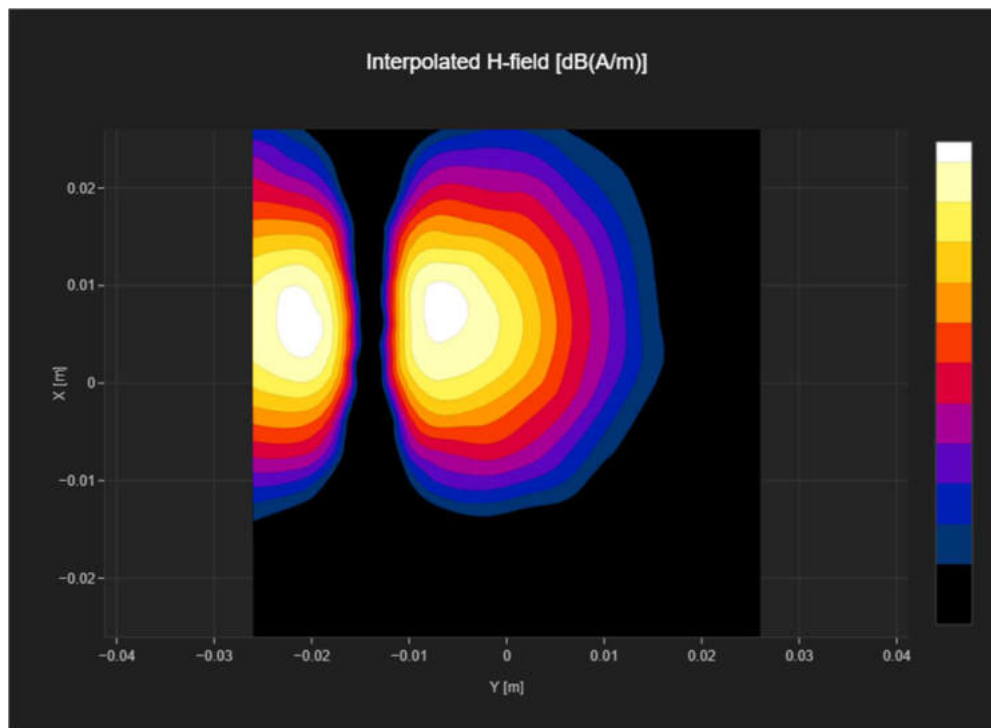

T-Coil Noise Test Report

Measurement performed on January 23, 2024 at 03:32

Device Under Test

Manufacturer	Model	Dimensions [mm]	Speaker Position [mm]
		146.2 x 71.8 x 7.5	144.3

Hardware Setup

Probe Name	Probe Calibration Date	DAE Name	DAE Calibration Date
AM1DV3 - 3082	February 16, 2023	DAE4 Sn1291	March 17, 2023

Communication Systems

Band Name	Communication Systems Name	Channel	Frequency [MHz]
GSM 850	GSM-FDD (TDMA, GMSK)	190	836.6

Grid Settings

Extent X [mm]	Extent Y [mm]	Step X [mm]	Step Y [mm]	Distance [mm]
52.0	52.0	4.0	4.0	10.0

Results

Secondary Group Point Count	Secondary Group Max Longitudinal	Secondary Group Max Transverse	Hmax [dB(A/m)]
676	26	26	-43.14

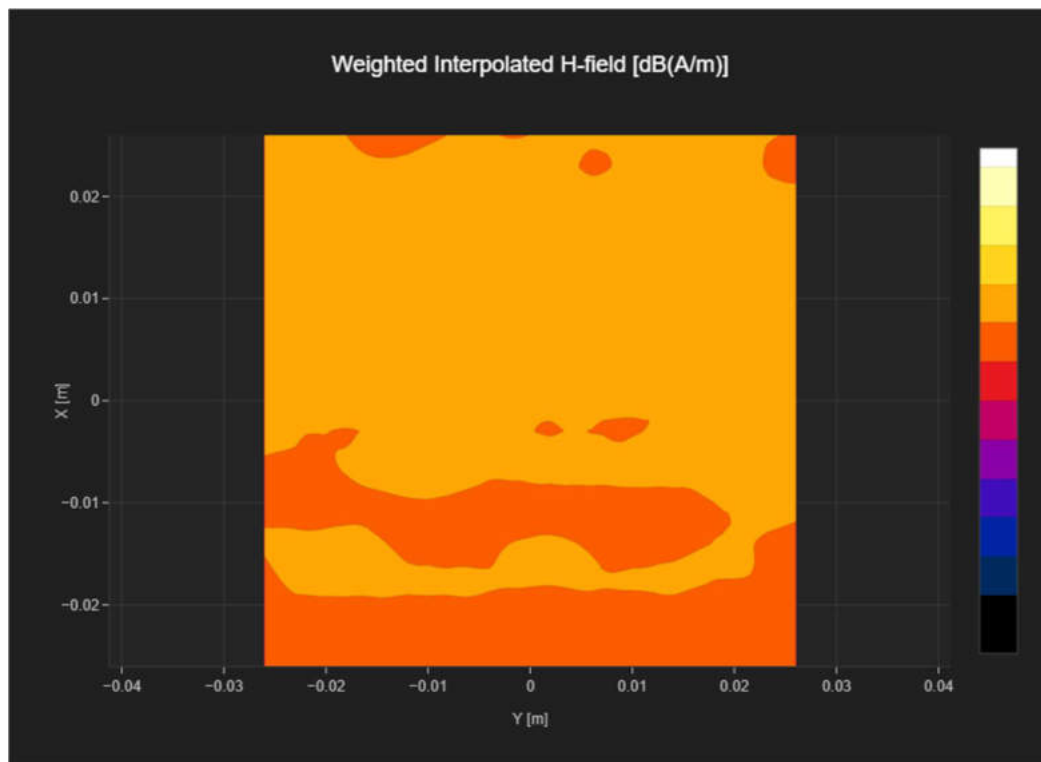

T-Coil Signal Test Report

Measurement performed on January 29, 2024 at 20:17

Device Under Test

Manufacturer	Model	Dimensions [mm]	Speaker Position [mm]
		146.2 x 71.8 x 7.5	144.3

Hardware Setup

Probe Name	Probe Calibration Date	DAE Name	DAE Calibration Date
AM1DV3 - 3082	February 16, 2023	DAE4 Sn1291	March 17, 2023

Communication Systems

Band Name	Communication Systems Name	Channel	Frequency [MHz]
GSM 850	GPRS-FDD (TDMA, GMSK)	190	836.6

Grid Settings

Extent X [mm]	Extent Y [mm]	Step X [mm]	Step Y [mm]	Distance [mm]
52.0	52.0	4.0	4.0	10.0

Results

Audio File	Measurement Duration [s]	Margin Upper Bound [dB]	Margin Lower Bound [dB]
48k_voice_300-3000_2s.wav	2.0	0.66	2.0

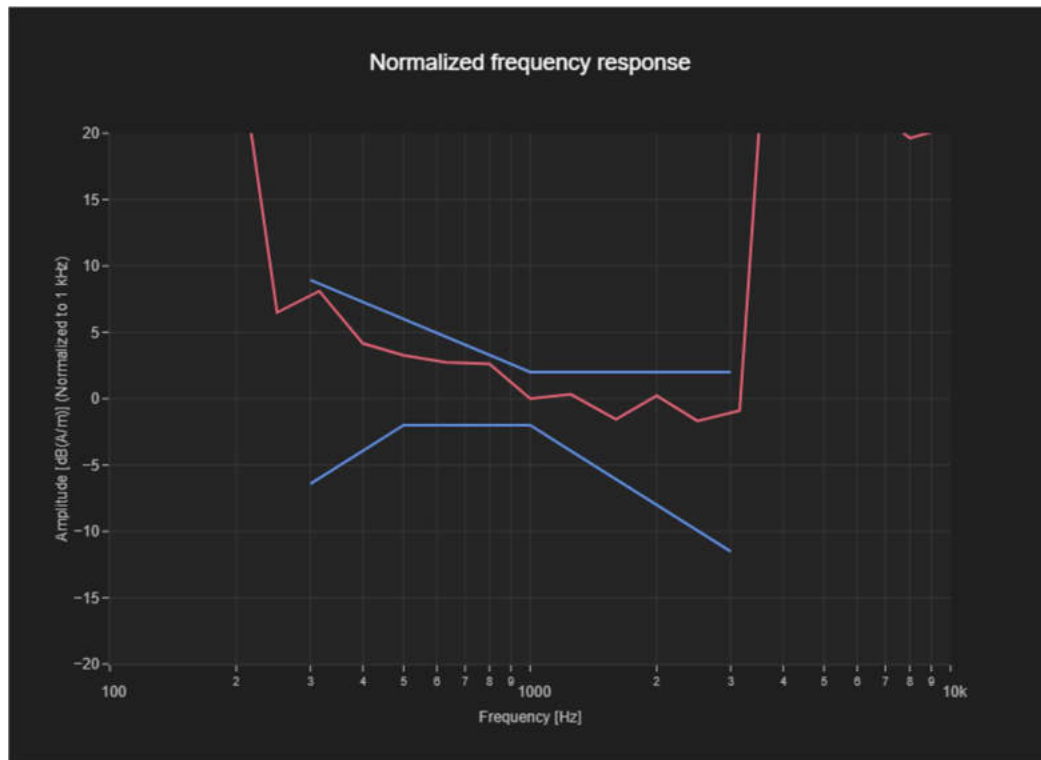

T-Coil Coupling Mode Test Report

Results

Primary Group Contiguous Point Count	Secondary Group Point Count	Secondary Group Max Longitudinal	Secondary Group Max Transverse
198	676	26	26

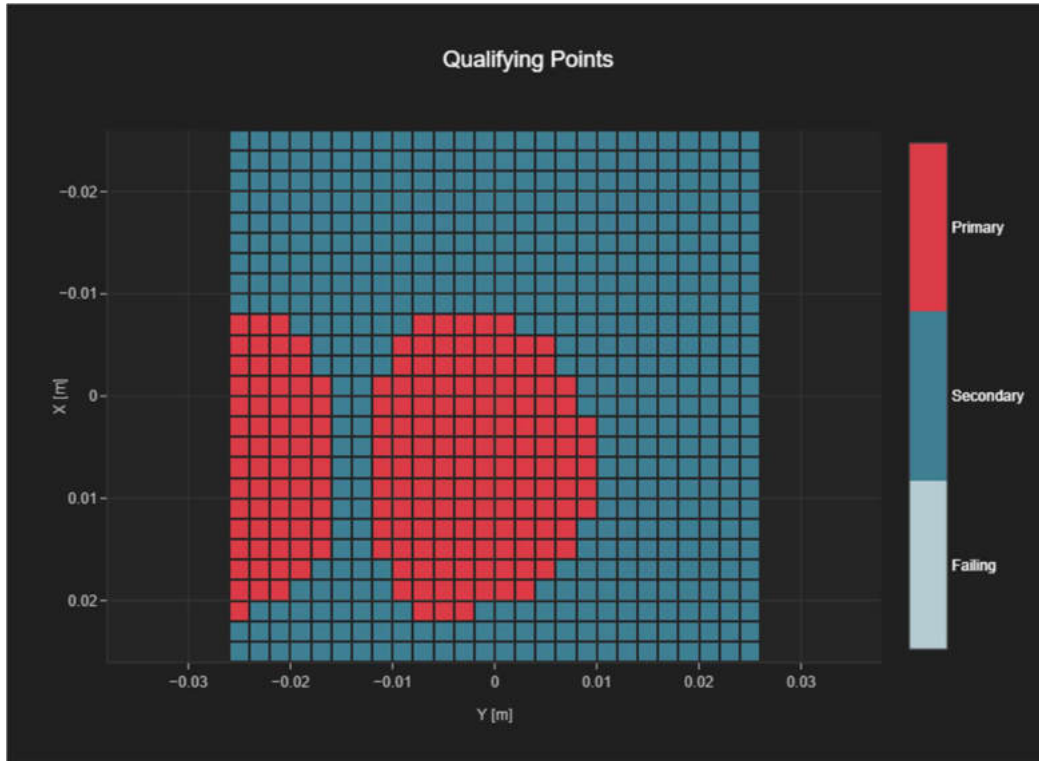

Plot 2 T-Coil GSM 850 (Second Supply)
T-Coil Signal Test Report

Measurement performed on January 30, 2024 at 10:24

Device Under Test

Manufacturer	Model	Dimensions [mm]	Speaker Position [mm]
		146.2 x 71.8 x 7.5	144.3

Hardware Setup

Probe Name	Probe Calibration Date	DAE Name	DAE Calibration Date
AM1DV3 - 3082	February 16, 2023	DAE4 Sn1291	March 17, 2023

Communication Systems

Band Name	Communication Systems Name	Channel	Frequency [MHz]
E-GSM 900	GSM-FDD (TDMA, GMSK)	38	897.6

Grid Settings

Extent X [mm]	Extent Y [mm]	Step X [mm]	Step Y [mm]	Distance [mm]
52.0	52.0	4.0	4.0	10.0

Results

Audio File	Measurement Duration [s]	Gain [dB]	Hmax [dB(A/m)]
48k_voice_1kHz_1s.wav	2.0	-12.35	-3.99

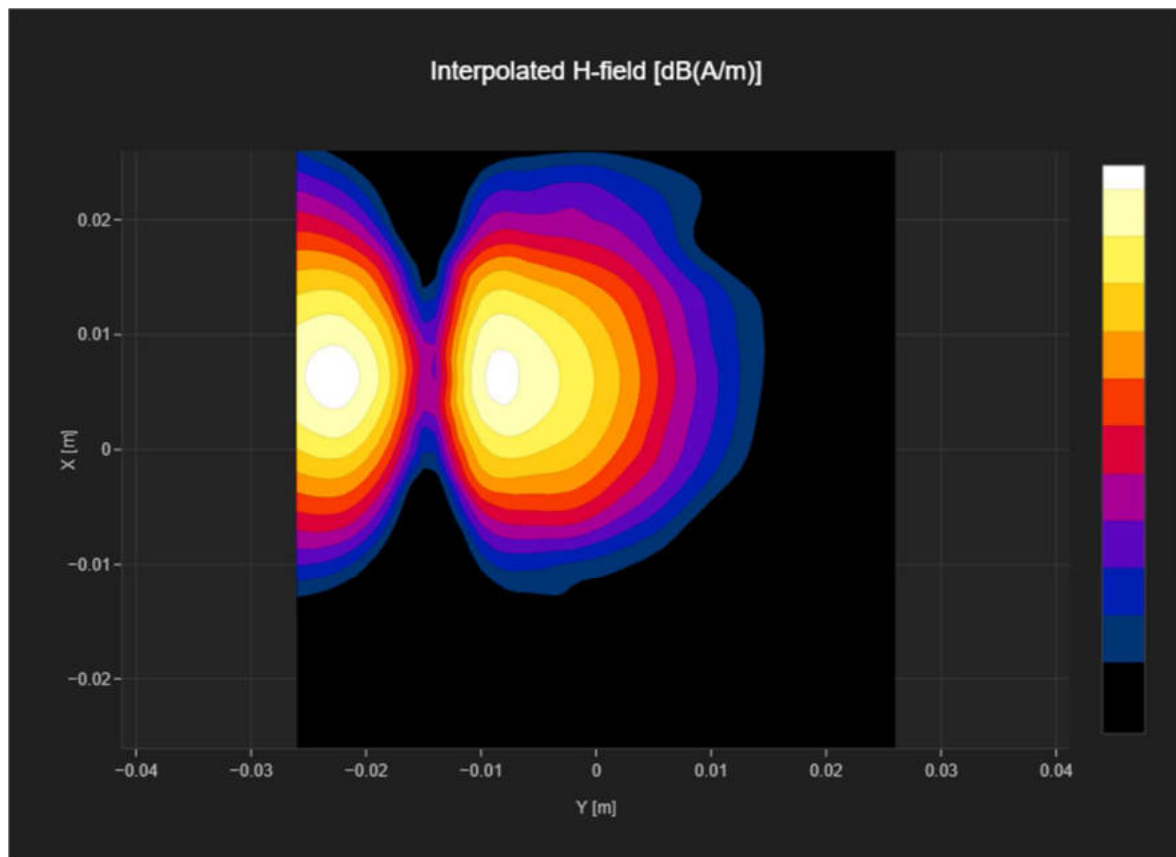

T-Coil Noise Test Report

Measurement performed on January 30, 2024 at 20:16

Device Under Test

Manufacturer	Model	Dimensions [mm]	Speaker Position [mm]
		146.2 x 71.8 x 7.5	144.3

Hardware Setup

Probe Name	Probe Calibration Date	DAE Name	DAE Calibration Date
AM1DV3 - 3082	February 16, 2023	DAE4 Sn1291	March 17, 2023

Communication Systems

Band Name	Communication Systems Name	Channel	Frequency [MHz]
GSM 850	GSM-FDD (TDMA, GMSK)	190	836.6

Grid Settings

Extent X [mm]	Extent Y [mm]	Step X [mm]	Step Y [mm]	Distance [mm]
52.0	52.0	4.0	4.0	10.0

Results

Secondary Group Point Count	Secondary Group Max Longitudinal	Secondary Group Max Transverse	Hmax [dB(A/m)]
676	26	26	-42.74

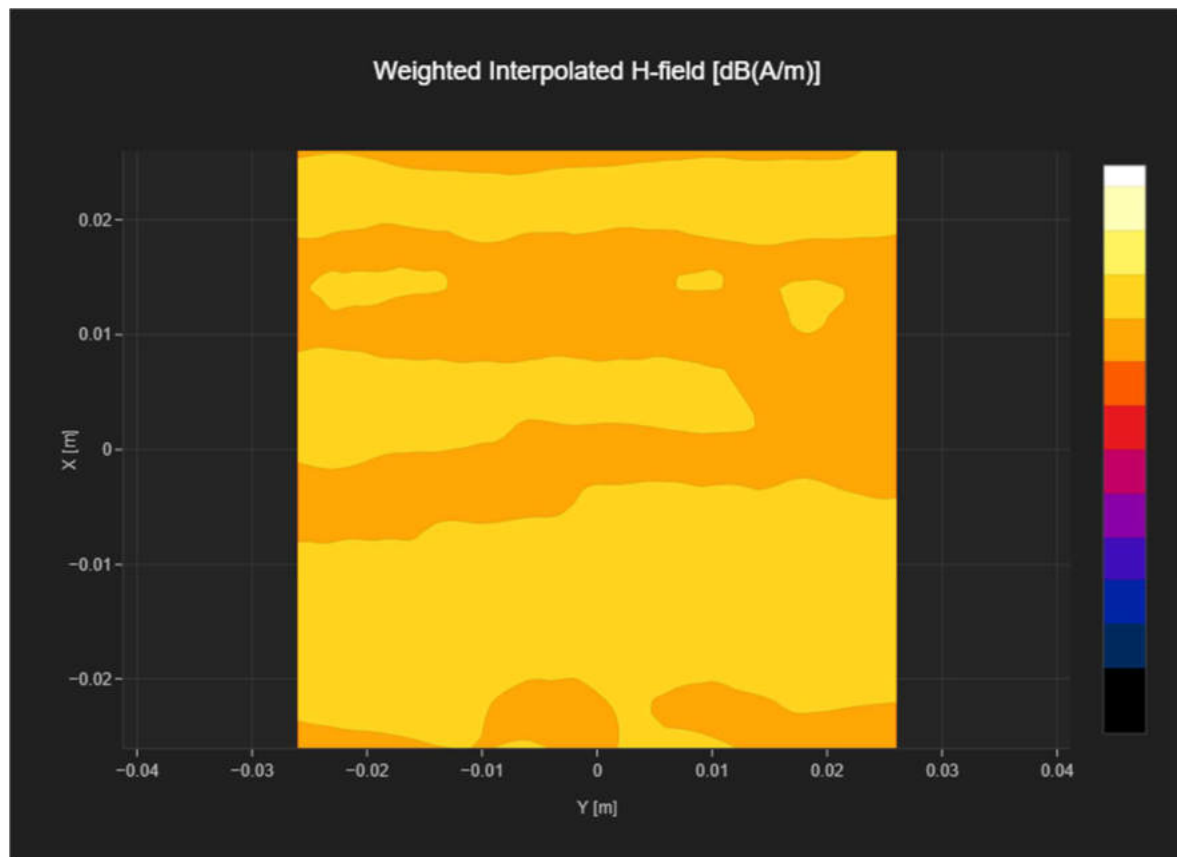

T-Coil Signal Test Report

Measurement performed on January 30, 2024 at 10:24

Device Under Test

Manufacturer	Model	Dimensions [mm]	Speaker Position [mm]
		146.2 x 71.8 x 7.5	144.3

Hardware Setup

Probe Name	Probe Calibration Date	DAE Name	DAE Calibration Date
AM1DV3 - 3082	February 16, 2023	DAE4 Sn1291	March 17, 2023

Communication Systems

Band Name	Communication Systems Name	Channel	Frequency [MHz]
E-GSM 900	GSM-FDD (TDMA, GMSK)	38	897.6

Grid Settings

Extent X [mm]	Extent Y [mm]	Step X [mm]	Step Y [mm]	Distance [mm]
52.0	52.0	4.0	4.0	10.0

Results

Audio File	Measurement Duration [s]	Margin Upper Bound [dB]	Margin Lower Bound [dB]
48k_voice_300-3000_2s.wav	2.0	0.56	2.0

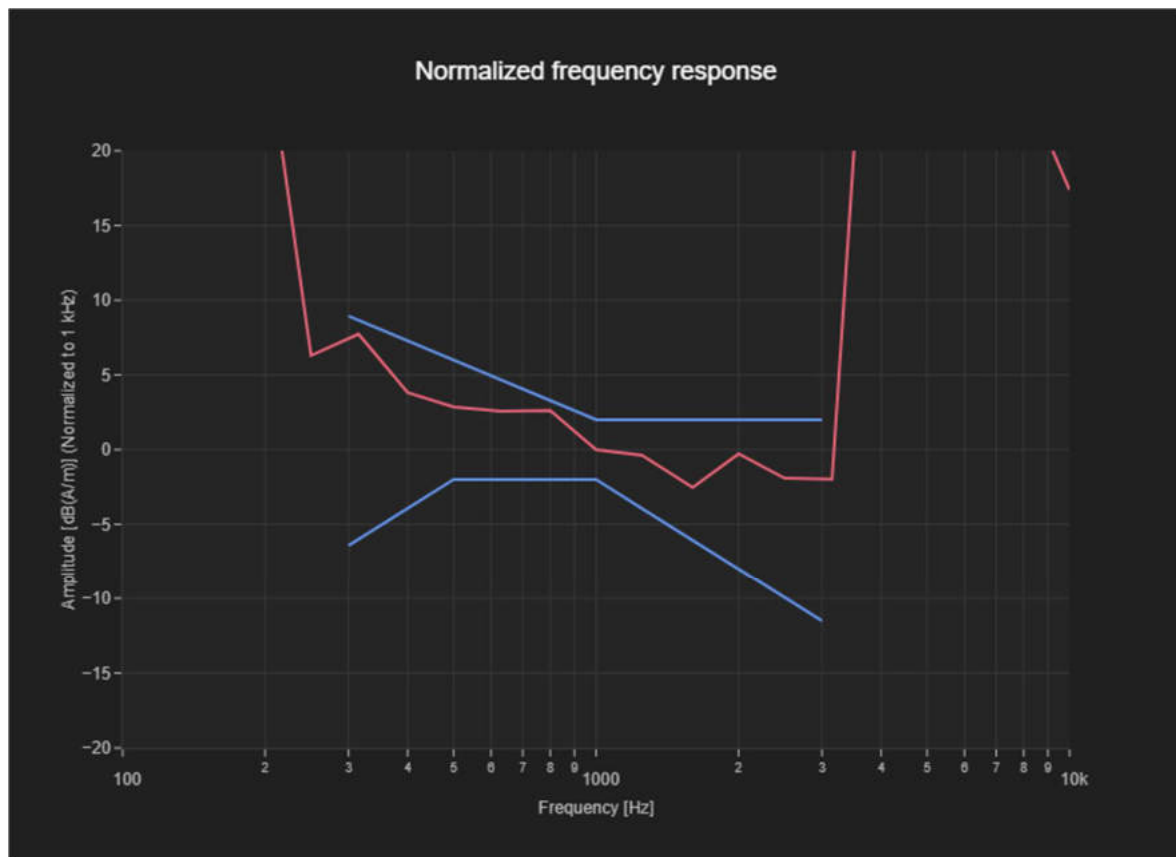

T-Coil Coupling Mode Test Report

Results

Primary Group Contiguous Point Count	Secondary Group Point Count	Secondary Group Max Longitudinal	Secondary Group Max Transverse
232	676	26	26

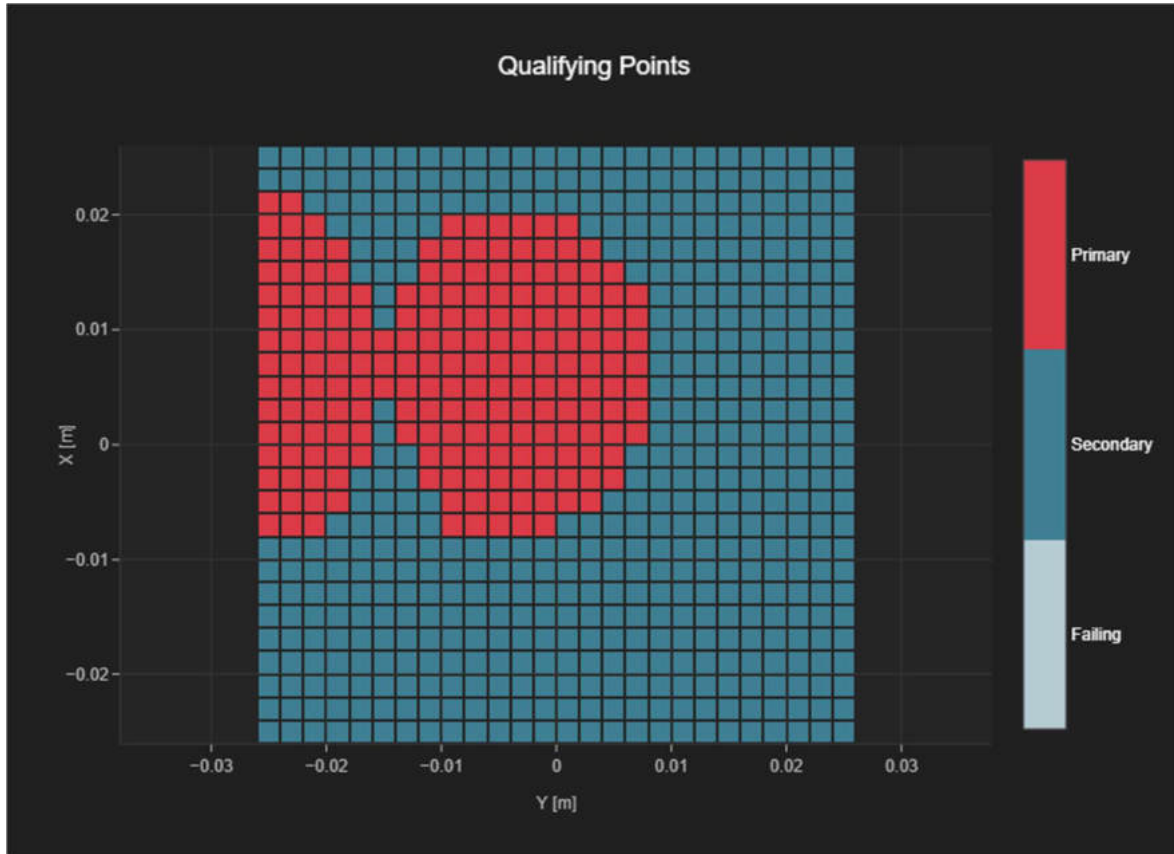

Plot 3 T-Coil GSM 1900
T-Coil Signal Test Report

Measurement performed on January 30, 2024 at 09:55

Device Under Test

Manufacturer	Model	Dimensions [mm]	Speaker Position [mm]
		146.2 x 71.8 x 7.5	144.3

Hardware Setup

Probe Name	Probe Calibration Date	DAE Name	DAE Calibration Date
AM1DV3 - 3082	February 16, 2023	DAE4 Sn1291	March 17, 2023

Communication Systems

Band Name	Communication Systems Name	Channel	Frequency [MHz]
PCS 1900	GSM-FDD (TDMA, GMSK)	661	1880.0

Grid Settings

Extent X [mm]	Extent Y [mm]	Step X [mm]	Step Y [mm]	Distance [mm]
52.0	52.0	4.0	4.0	10.0

Results

Audio File	Measurement Duration [s]	Gain [dB]	Hmax [dB(A/m)]
48k_voice_1kHz_1s.wav	2.0	-12.35	-5.03

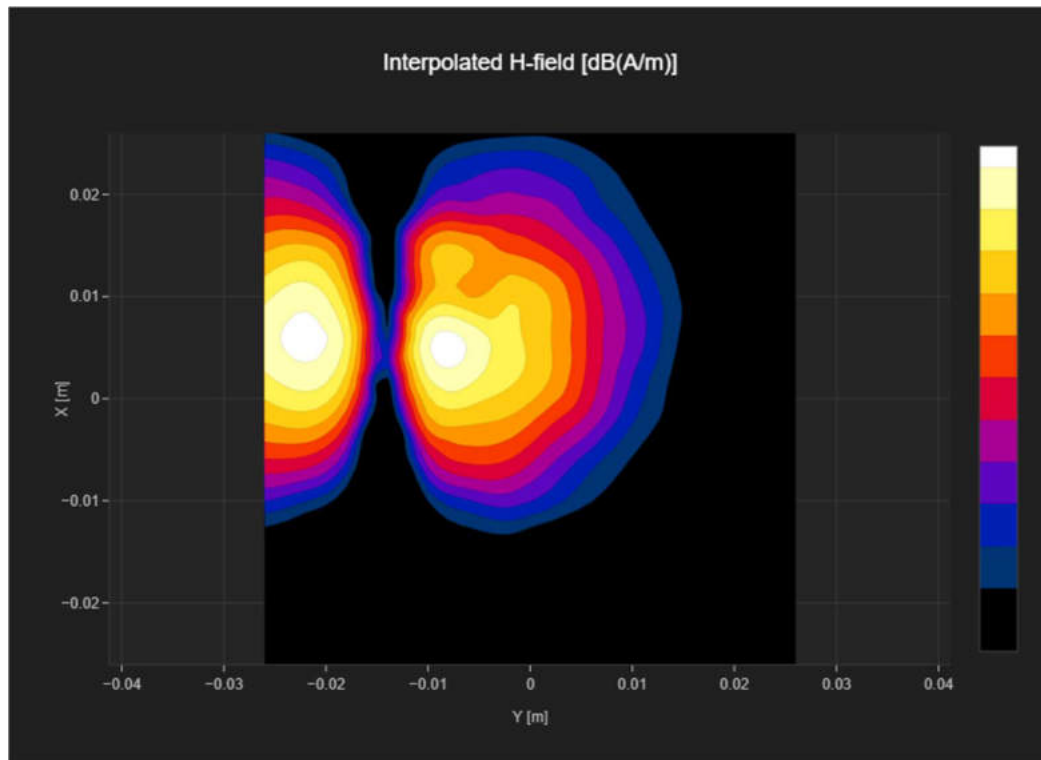

T-Coil Noise Test Report

Measurement performed on January 23, 2024 at 05:50

Device Under Test

Manufacturer	Model	Dimensions [mm]	Speaker Position [mm]
		146.2 x 71.8 x 7.5	144.3

Hardware Setup

Probe Name	Probe Calibration Date	DAE Name	DAE Calibration Date
AM1DV3 - 3082	February 16, 2023	DAE4 Sn1291	March 17, 2023

Communication Systems

Band Name	Communication Systems Name	Channel	Frequency [MHz]
PCS 1900	GSM-FDD (TDMA, GMSK)	661	1880.0

Grid Settings

Extent X [mm]	Extent Y [mm]	Step X [mm]	Step Y [mm]	Distance [mm]
52.0	52.0	4.0	4.0	10.0

Results

Secondary Group Point Count	Secondary Group Max Longitudinal	Secondary Group Max Transverse	Hmax [dB(A/m)]
676	26	26	-43.99

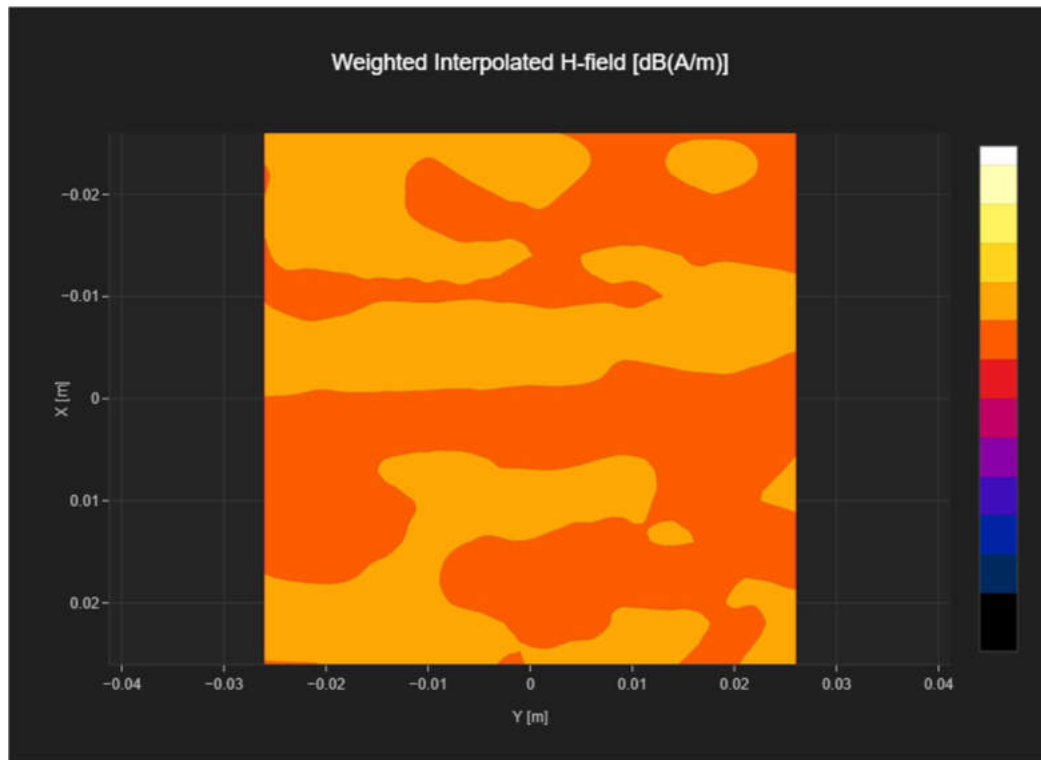

T-Coil Signal Test Report

Measurement performed on January 30, 2024 at 09:55

Device Under Test

Manufacturer	Model	Dimensions [mm]	Speaker Position [mm]
		146.2 x 71.8 x 7.5	144.3

Hardware Setup

Probe Name	Probe Calibration Date	DAE Name	DAE Calibration Date
AM1DV3 - 3082	February 16, 2023	DAE4 Sn1291	March 17, 2023

Communication Systems

Band Name	Communication Systems Name	Channel	Frequency [MHz]
PCS 1900	GSM-FDD (TDMA, GMSK)	661	1880.0

Grid Settings

Extent X [mm]	Extent Y [mm]	Step X [mm]	Step Y [mm]	Distance [mm]
52.0	52.0	4.0	4.0	10.0

Results

Audio File	Measurement Duration [s]	Margin Upper Bound [dB]	Margin Lower Bound [dB]
48k_voice_300-3000_2s.wav	2.0	1.25	2.0

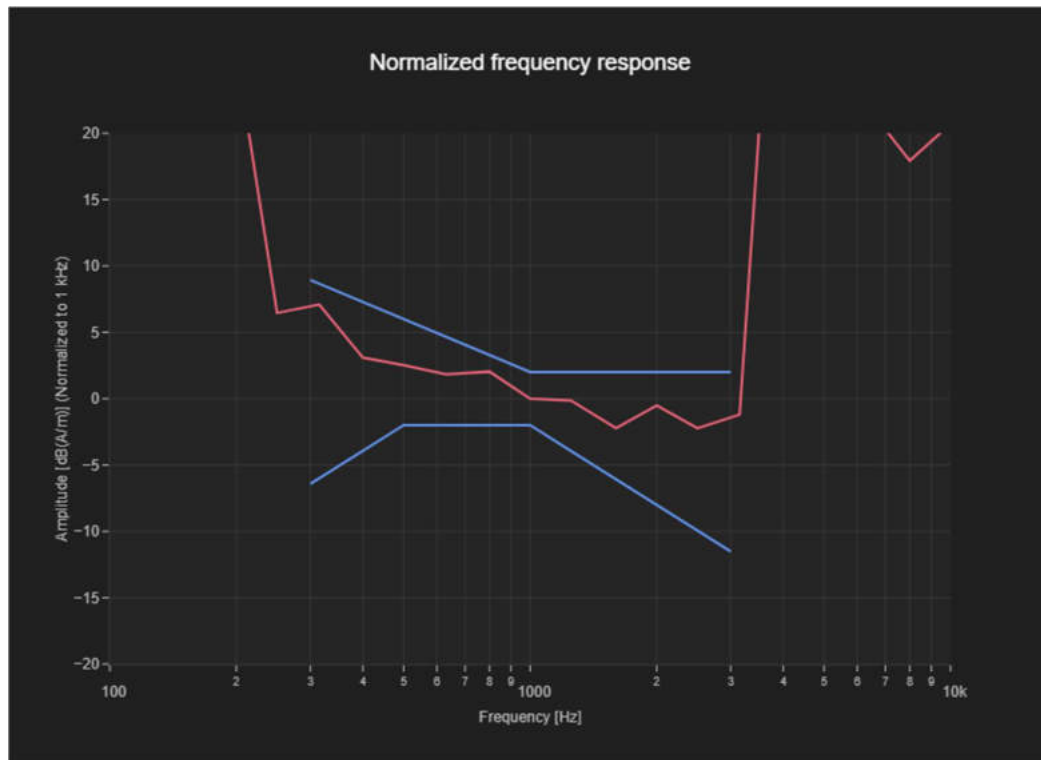

T-Coil Coupling Mode Test Report

Results

Primary Group Contiguous Point Count	Secondary Group Point Count	Secondary Group Max Longitudinal	Secondary Group Max Transverse
198	676	26	26



Plot 4 T-Coil WCDMA Band 2

T-Coil Signal Test Report

Measurement performed on January 29, 2024 at 18:51

Device Under Test

Manufacturer	Model	Dimensions [mm]	Speaker Position [mm]
		146.2 x 71.8 x 7.5	144.3

Hardware Setup

Probe Name	Probe Calibration Date	DAE Name	DAE Calibration Date
AM1DV3 - 3082	February 16, 2023	DAE4 Sn1291	March 17, 2023

Communication Systems

Band Name	Communication Systems Name	Channel	Frequency [MHz]
Band 2, UTRA/FDD	UMTS-FDD (WCDMA)	9538	1907.6

Grid Settings

Extent X [mm]	Extent Y [mm]	Step X [mm]	Step Y [mm]	Distance [mm]
52.0	52.0	4.0	4.0	10.0

Results

Audio File	Measurement Duration [s]	Gain [dB]	Hmax [dB(A/m)]
48k_voice_1kHz_1s.wav	2.0	-12.37	-8.84

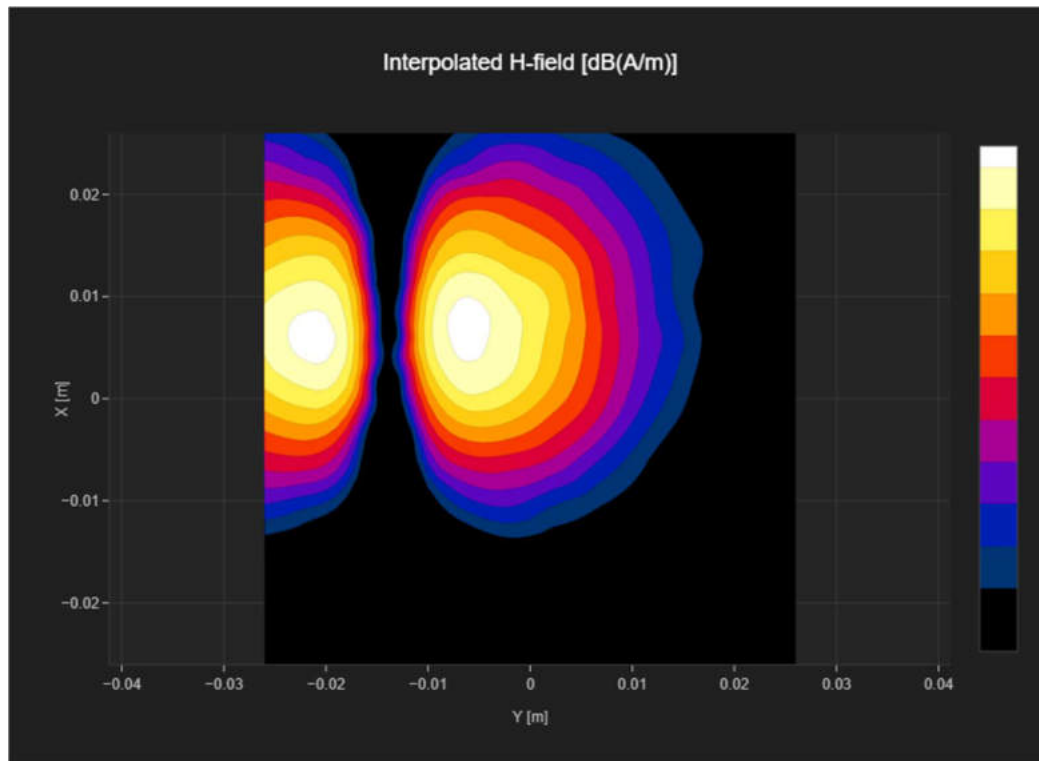

T-Coil Noise Test Report

Measurement performed on January 25, 2024 at 20:50

Device Under Test

Manufacturer	Model	Dimensions [mm]	Speaker Position [mm]
		146.2 x 71.8 x 7.5	144.3

Hardware Setup

Probe Name	Probe Calibration Date	DAE Name	DAE Calibration Date
AM1DV3 - 3082	February 16, 2023	DAE4 Sn1291	March 17, 2023

Communication Systems

Band Name	Communication Systems Name	Channel	Frequency [MHz]
Band 2, UTRA/FDD	UMTS-FDD (WCDMA)	9538	1907.6

Grid Settings

Extent X [mm]	Extent Y [mm]	Step X [mm]	Step Y [mm]	Distance [mm]
52.0	52.0	4.0	4.0	10.0

Results

Secondary Group Point Count	Secondary Group Max Longitudinal	Secondary Group Max Transverse	Hmax [dB(A/m)]
676	26	26	-42.24

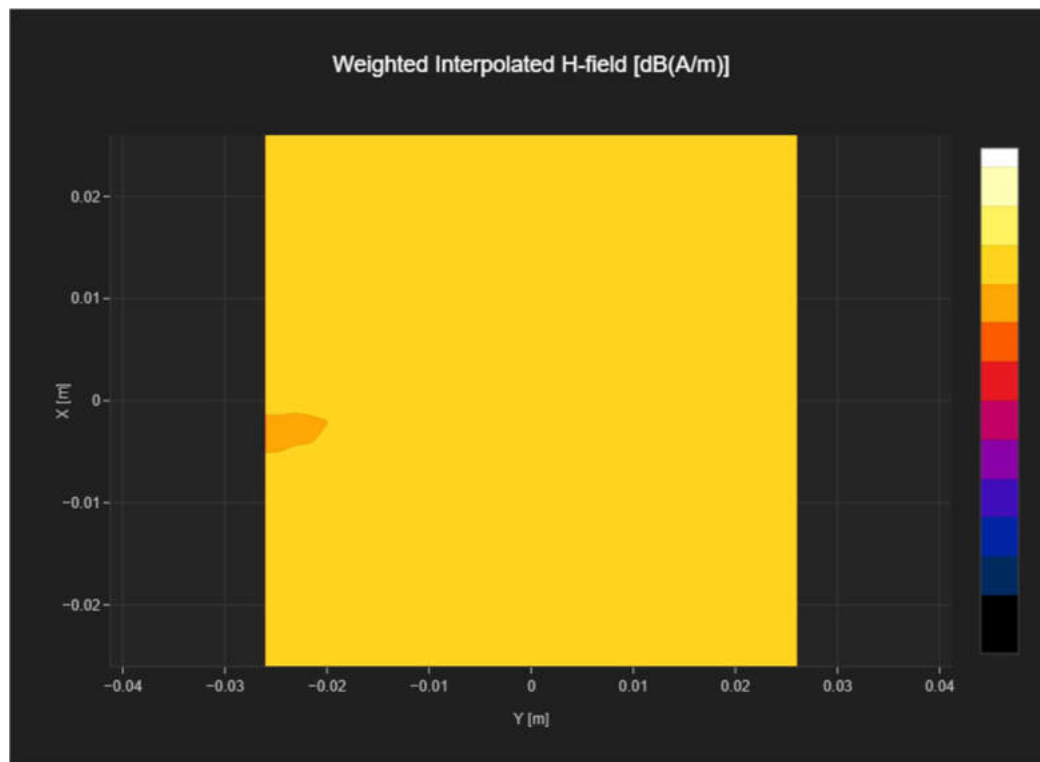

T-Coil Signal Test Report

Measurement performed on January 29, 2024 at 18:51

Device Under Test

Manufacturer	Model	Dimensions [mm]	Speaker Position [mm]
		146.2 x 71.8 x 7.5	144.3

Hardware Setup

Probe Name	Probe Calibration Date	DAE Name	DAE Calibration Date
AM1DV3 - 3082	February 16, 2023	DAE4 Sn1291	March 17, 2023

Communication Systems

Band Name	Communication Systems Name	Channel	Frequency [MHz]
Band 2, UTRA/FDD	UMTS-FDD (WCDMA)	9538	1907.6

Grid Settings

Extent X [mm]	Extent Y [mm]	Step X [mm]	Step Y [mm]	Distance [mm]
52.0	52.0	4.0	4.0	10.0

Results

Audio File	Measurement Duration [s]	Margin Upper Bound [dB]	Margin Lower Bound [dB]
48k_voice_300-3000_2s.wav	2.0	1.4	2.0

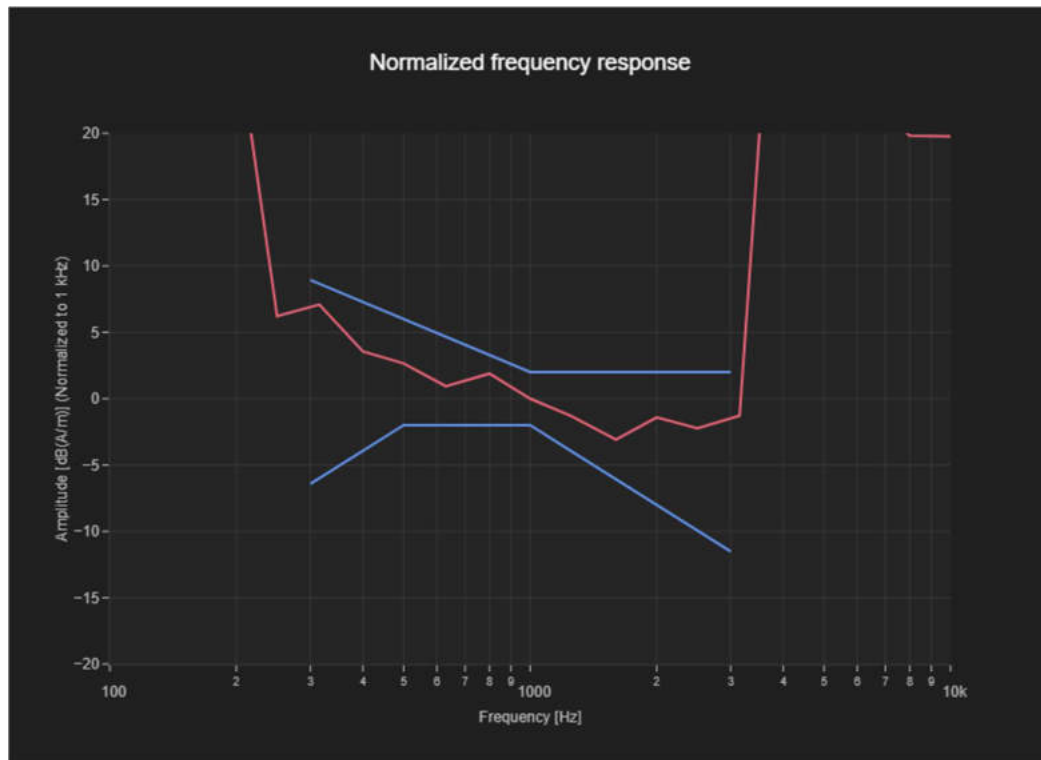

T-Coil Coupling Mode Test Report

Results

Primary Group Contiguous Point Count	Secondary Group Point Count	Secondary Group Max Longitudinal	Secondary Group Max Transverse
149	676	26	26



Plot 5 T-Coil WCDMA Band 2 (Second Supply)

T-Coil Signal Test Report

Measurement performed on January 30, 2024 at 11:03

Device Under Test

Manufacturer	Model	Dimensions [mm]	Speaker Position [mm]
		146.2 x 71.8 x 7.5	144.3

Hardware Setup

Probe Name	Probe Calibration Date	DAE Name	DAE Calibration Date
AM1DV3 - 3082	February 16, 2023	DAE4 Sn1291	March 17, 2023

Communication Systems

Band Name	Communication Systems Name	Channel	Frequency [MHz]
Band 2, UTRA/FDD	UMTS-FDD (WCDMA)	9538	1907.6

Grid Settings

Extent X [mm]	Extent Y [mm]	Step X [mm]	Step Y [mm]	Distance [mm]
52.0	52.0	4.0	4.0	10.0

Results

Audio File	Measurement Duration [s]	Gain [dB]	Hmax [dB(A/m)]
48k_voice_1kHz_1s.wav	2.0	-12.35	-1.72

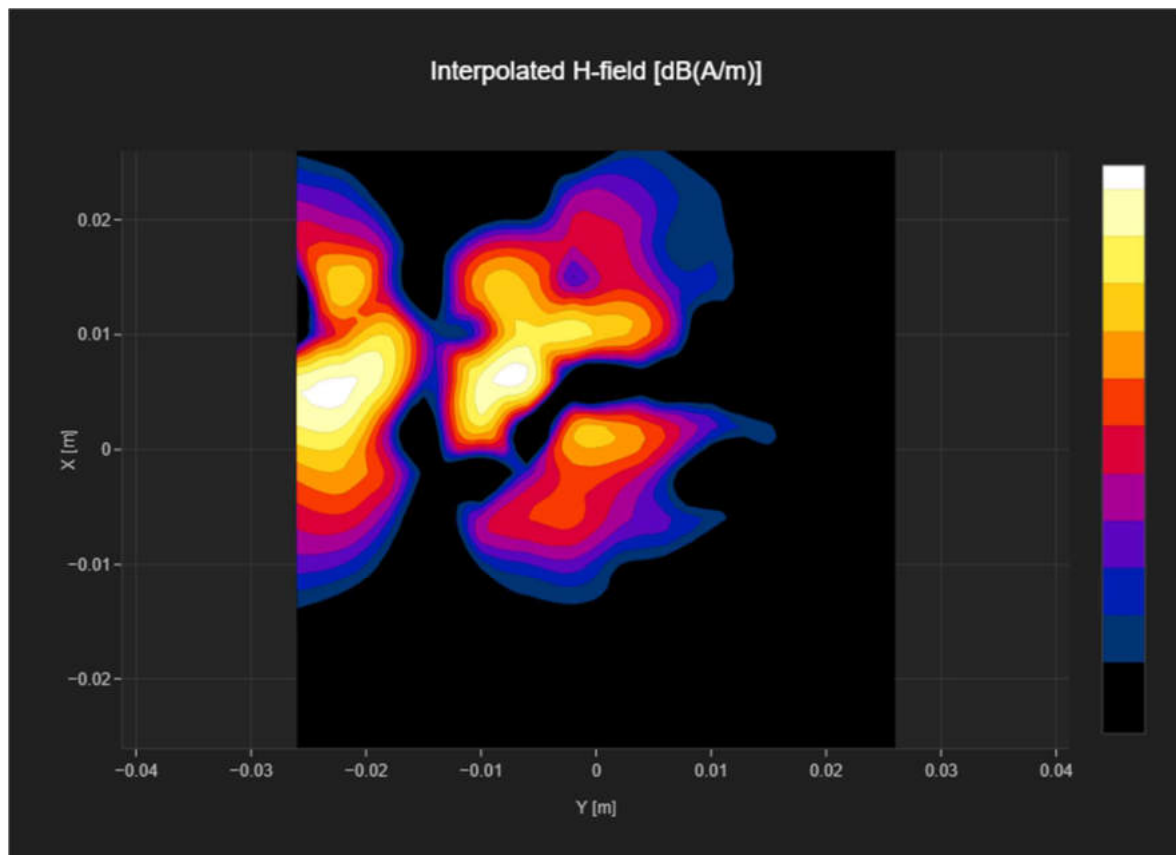

T-Coil Noise Test Report

Measurement performed on January 30, 2024 at 20:28

Device Under Test

Manufacturer	Model	Dimensions [mm]	Speaker Position [mm]
		146.2 x 71.8 x 7.5	144.3

Hardware Setup

Probe Name	Probe Calibration Date	DAE Name	DAE Calibration Date
AM1DV3 - 3082	February 16, 2023	DAE4 Sn1291	March 17, 2023

Communication Systems

Band Name	Communication Systems Name	Channel	Frequency [MHz]
Band 2, UTRA/FDD	UMTS-FDD (WCDMA)	9538	1907.6

Grid Settings

Extent X [mm]	Extent Y [mm]	Step X [mm]	Step Y [mm]	Distance [mm]
52.0	52.0	4.0	4.0	10.0

Results

Secondary Group Point Count	Secondary Group Max Longitudinal	Secondary Group Max Transverse	Hmax [dB(A/m)]
676	26	26	-42.83

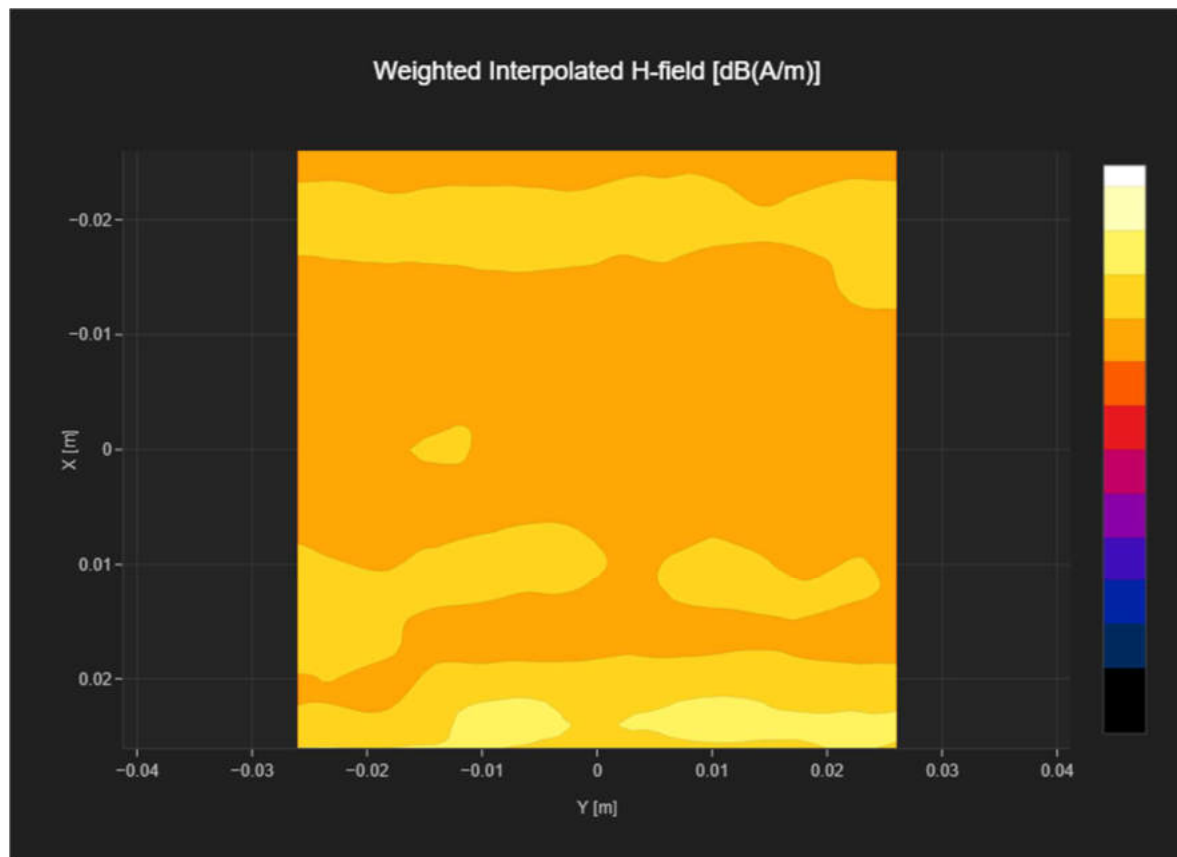

T-Coil Signal Test Report

Measurement performed on January 30, 2024 at 11:03

Device Under Test

Manufacturer	Model	Dimensions [mm]	Speaker Position [mm]
		146.2 x 71.8 x 7.5	144.3

Hardware Setup

Probe Name	Probe Calibration Date	DAE Name	DAE Calibration Date
AM1DV3 - 3082	February 16, 2023	DAE4 Sn1291	March 17, 2023

Communication Systems

Band Name	Communication Systems Name	Channel	Frequency [MHz]
Band 1, UTRA/FDD	UMTS-FDD (WCDMA)	9888	1977.6

Grid Settings

Extent X [mm]	Extent Y [mm]	Step X [mm]	Step Y [mm]	Distance [mm]
52.0	52.0	4.0	4.0	10.0

Results

Audio File	Measurement Duration [s]	Margin Upper Bound [dB]	Margin Lower Bound [dB]
48k_voice_300-3000_2s.wav	2.0	0.78	2.0

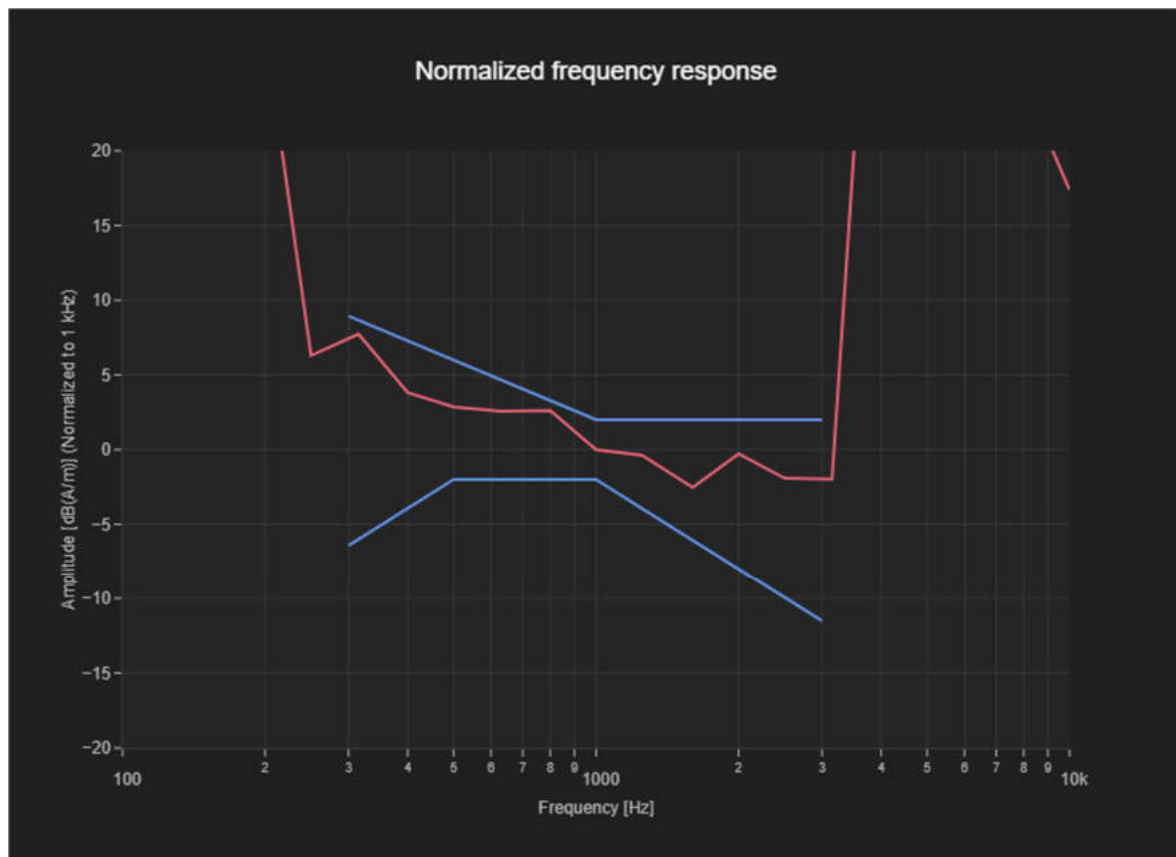

T-Coil Coupling Mode Test Report

Results

Primary Group Contiguous Point Count	Secondary Group Point Count	Secondary Group Max Longitudinal	Secondary Group Max Transverse
293	676	26	26

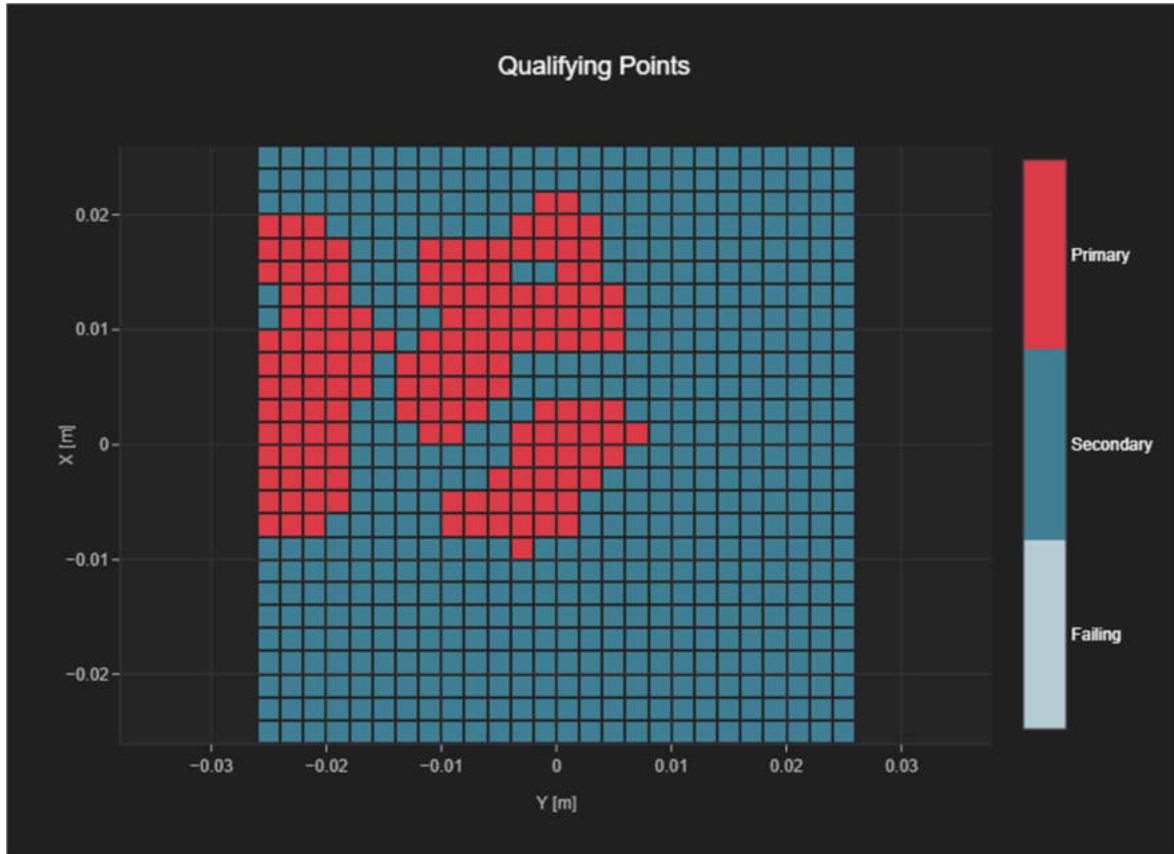

Plot 6 T-Coil WCDMA Band 5
T-Coil Signal Test Report

Measurement performed on January 29, 2024 at 19:03

Device Under Test

Manufacturer	Model	Dimensions [mm]	Speaker Position [mm]
		146.2 x 71.8 x 7.5	144.3

Hardware Setup

Probe Name	Probe Calibration Date	DAE Name	DAE Calibration Date
AM1DV3 - 3082	February 16, 2023	DAE4 Sn1291	March 17, 2023

Communication Systems

Band Name	Communication Systems Name	Channel	Frequency [MHz]
Band 5, UTRA/FDD	UMTS-FDD (WCDMA)	4233	846.6

Grid Settings

Extent X [mm]	Extent Y [mm]	Step X [mm]	Step Y [mm]	Distance [mm]
52.0	52.0	4.0	4.0	10.0

Results

Audio File	Measurement Duration [s]	Gain [dB]	Hmax [dB(A/m)]
48k_voice_1kHz_1s.wav	2.0	-12.37	-8.63

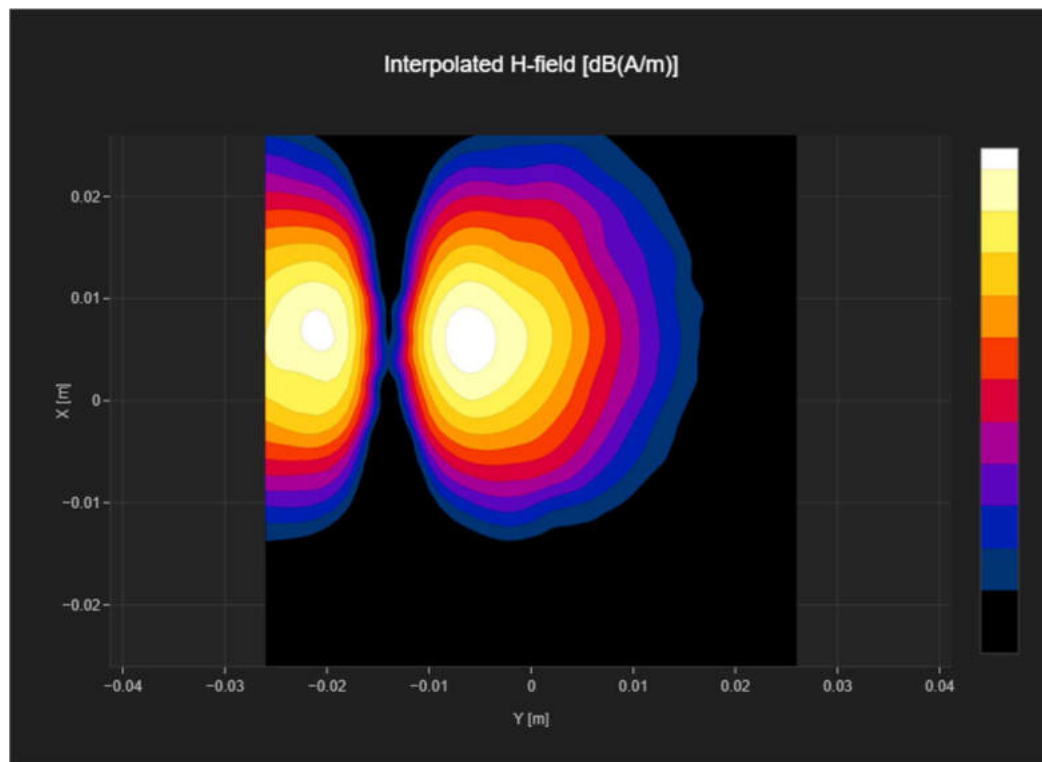

T-Coil Noise Test Report

Measurement performed on January 26, 2024 at 03:04

Device Under Test

Manufacturer	Model	Dimensions [mm]	Speaker Position [mm]
		146.2 x 71.8 x 7.5	144.3

Hardware Setup

Probe Name	Probe Calibration Date	DAE Name	DAE Calibration Date
AM1DV3 - 3082	February 16, 2023	DAE4 Sn1291	March 17, 2023

Communication Systems

Band Name	Communication Systems Name	Channel	Frequency [MHz]
Band 5, UTRA/FDD	UMTS-FDD (WCDMA)	4233	846.6

Grid Settings

Extent X [mm]	Extent Y [mm]	Step X [mm]	Step Y [mm]	Distance [mm]
52.0	52.0	4.0	4.0	10.0

Results

Secondary Group Point Count	Secondary Group Max Longitudinal	Secondary Group Max Transverse	Hmax [dB(A/m)]
676	26	26	-42.19

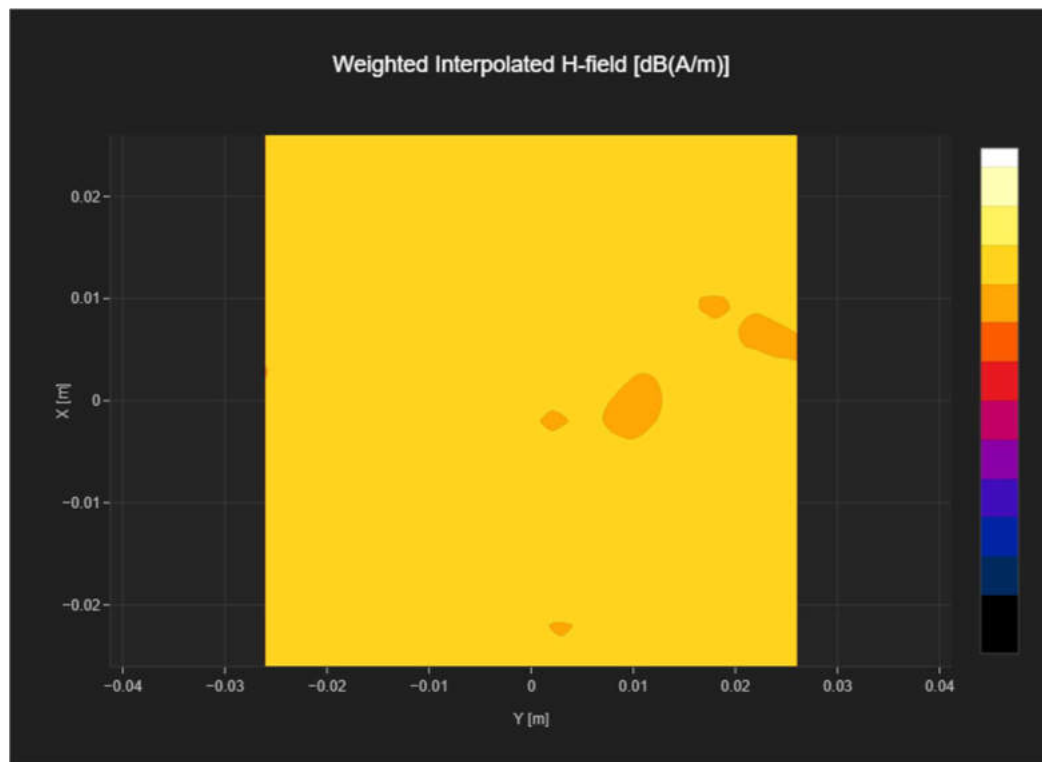

T-Coil Signal Test Report

Measurement performed on January 29, 2024 at 19:03

Device Under Test

Manufacturer	Model	Dimensions [mm]	Speaker Position [mm]
		146.2 x 71.8 x 7.5	144.3

Hardware Setup

Probe Name	Probe Calibration Date	DAE Name	DAE Calibration Date
AM1DV3 - 3082	February 16, 2023	DAE4 Sn1291	March 17, 2023

Communication Systems

Band Name	Communication Systems Name	Channel	Frequency [MHz]
Band 5, UTRA/FDD	UMTS-FDD (WCDMA)	4233	846.6

Grid Settings

Extent X [mm]	Extent Y [mm]	Step X [mm]	Step Y [mm]	Distance [mm]
52.0	52.0	4.0	4.0	10.0

Results

Audio File	Measurement Duration [s]	Margin Upper Bound [dB]	Margin Lower Bound [dB]
48k_voice_300-3000_2s.wav	2.0	0.51	2.0

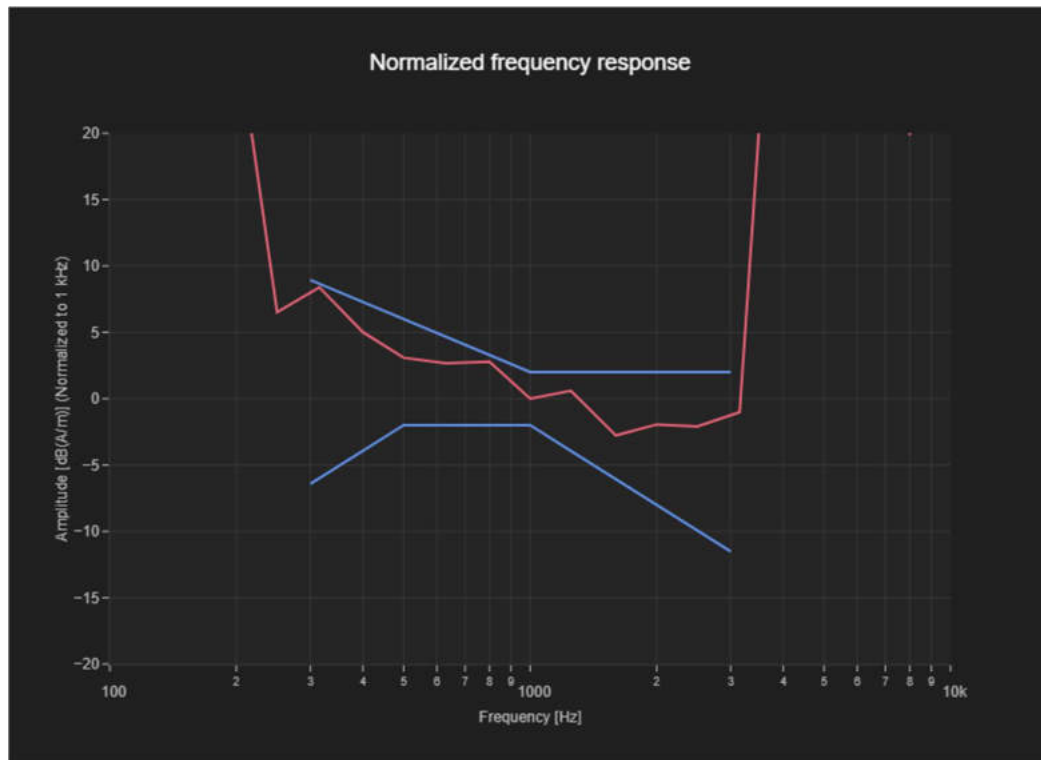

T-Coil Coupling Mode Test Report

Results

Primary Group Contiguous Point Count	Secondary Group Point Count	Secondary Group Max Longitudinal	Secondary Group Max Transverse
150	676	26	26



Plot 7 T-Coil LTE FDD Band 2

T-Coil Signal Test Report

Measurement performed on January 25, 2024 at 01:08

Device Under Test

Manufacturer	Model	Dimensions [mm]	Speaker Position [mm]
		146.2 x 71.8 x 7.5	144.3

Hardware Setup

Probe Name	Probe Calibration Date	DAE Name	DAE Calibration Date
AM1DV3 - 3082	February 16, 2023	DAE4 Sn1291	January 29, 2023

Communication Systems

Band Name	Communication Systems Name	Channel	Frequency [MHz]
Band 2, E-UTRA/FDD	LTE-FDD (SC-FDMA, 1 RB, 20 MHz, QPSK)	18900	1880.0

Grid Settings

Extent X [mm]	Extent Y [mm]	Step X [mm]	Step Y [mm]	Distance [mm]
52.0	52.0	4.0	4.0	10.0

Results

Audio File	Measurement Duration [s]	Gain [dB]	Hmax [dB(A/m)]
48k_voice_1kHz_1s.wav	2.0	-11.94	-6.76

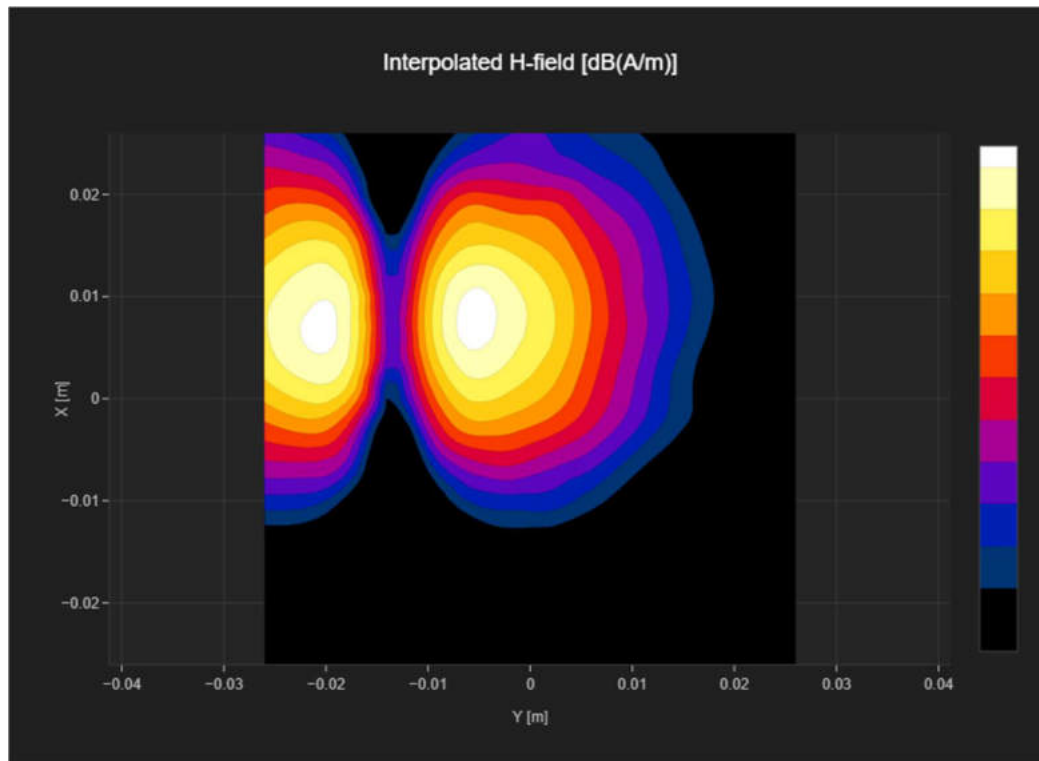

T-Coil Noise Test Report

Measurement performed on January 25, 2024 at 16:28

Device Under Test

Manufacturer	Model	Dimensions [mm]	Speaker Position [mm]
		146.2 x 71.8 x 7.5	144.3

Hardware Setup

Probe Name	Probe Calibration Date	DAE Name	DAE Calibration Date
AM1DV3 - 3082	February 16, 2023	DAE4 Sn1291	January 29, 2023

Communication Systems

Band Name	Communication Systems Name	Channel	Frequency [MHz]
Band 2, E-UTRA/FDD	LTE-FDD (SC-FDMA, 1 RB, 20 MHz, QPSK)	18900	1880.0

Grid Settings

Extent X [mm]	Extent Y [mm]	Step X [mm]	Step Y [mm]	Distance [mm]
52.0	52.0	4.0	4.0	10.0

Results

Secondary Group Point Count	Secondary Group Max Longitudinal	Secondary Group Max Transverse	Hmax [dB(A/m)]
676	26	26	-40.42

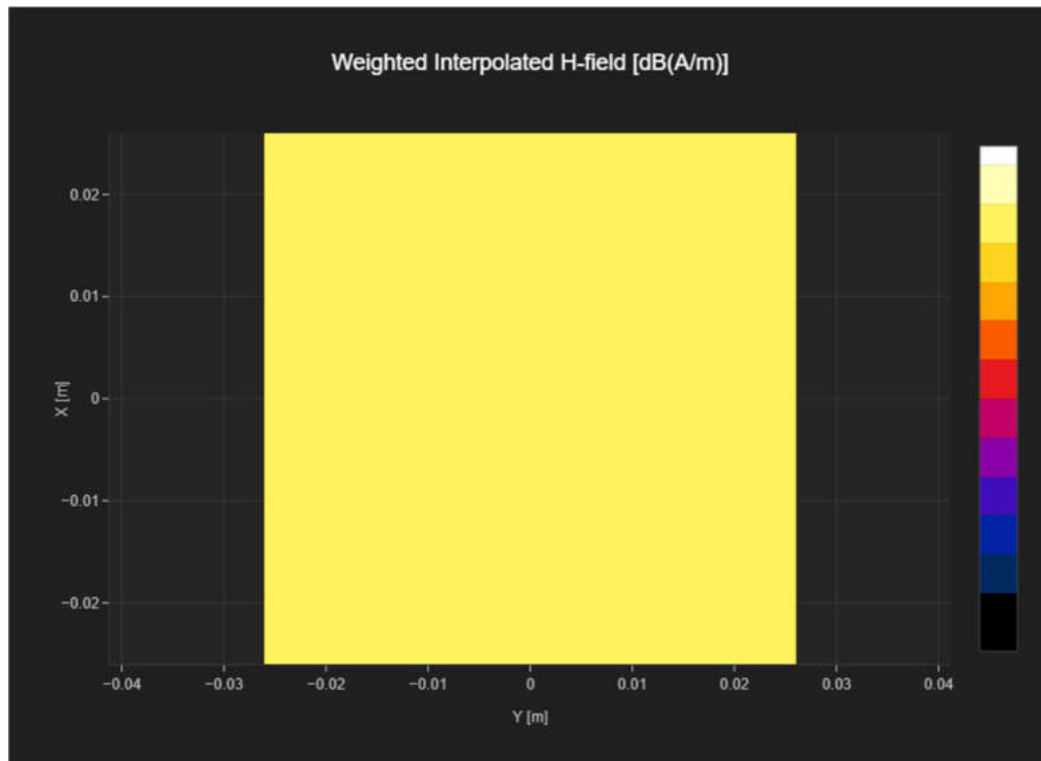

T-Coil Signal Test Report

Measurement performed on January 29, 2024 at 10:10

Device Under Test

Manufacturer	Model	Dimensions [mm]	Speaker Position [mm]
		146.2 x 71.8 x 7.5	144.3

Hardware Setup

Probe Name	Probe Calibration Date	DAE Name	DAE Calibration Date
AM1DV3 - 3082	February 16, 2023	DAE4 Sn1291	March 17, 2023

Communication Systems

Band Name	Communication Systems Name	Channel	Frequency [MHz]
Band 2, E-UTRA/FDD	LTE-FDD (SC-FDMA, 1 RB, 20 MHz, QPSK)	18900	1880.0

Grid Settings

Extent X [mm]	Extent Y [mm]	Step X [mm]	Step Y [mm]	Distance [mm]
52.0	52.0	4.0	4.0	10.0

Results

Audio File	Measurement Duration [s]	Margin Upper Bound [dB]	Margin Lower Bound [dB]
48k_voice_300-3000_2s.wav	2.0	1.48	1.83

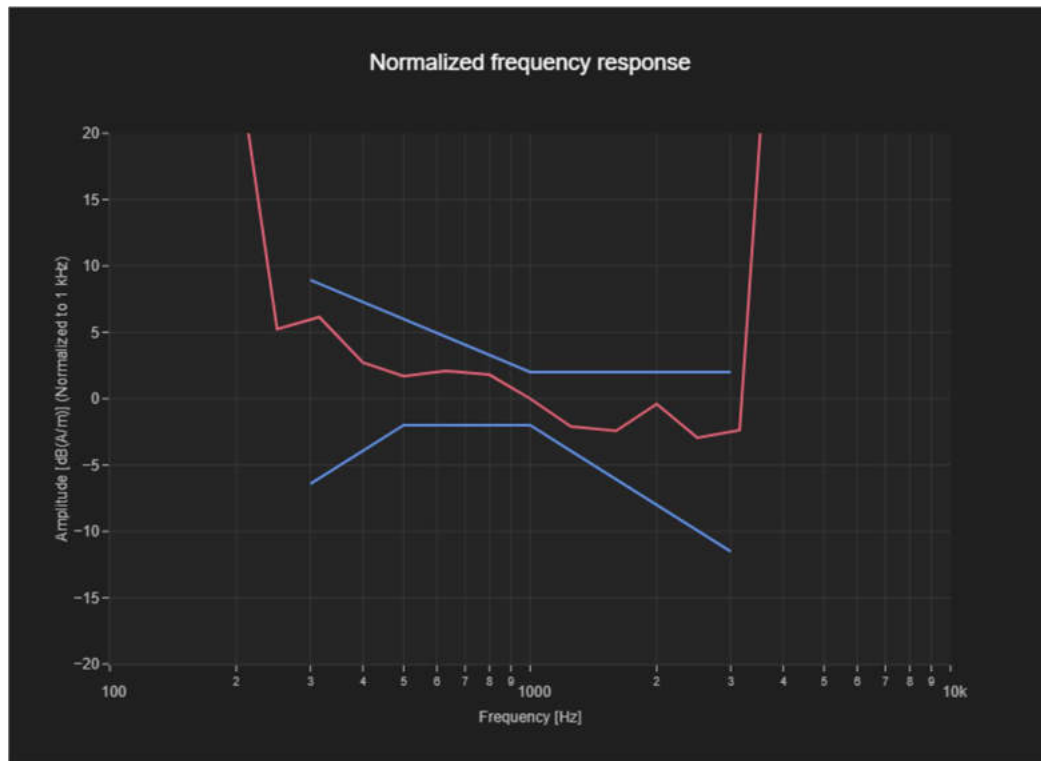

T-Coil Coupling Mode Test Report

Results

Primary Group Contiguous Point Count	Secondary Group Point Count	Secondary Group Max Longitudinal	Secondary Group Max Transverse
196	676	26	26



Plot 8 T-Coil LTE FDD Band 5

T-Coil Signal Test Report

Measurement performed on January 29, 2024 at 10:58

Device Under Test

Manufacturer	Model	Dimensions [mm]	Speaker Position [mm]
		146.2 x 71.8 x 7.5	144.3

Hardware Setup

Probe Name	Probe Calibration Date	DAE Name	DAE Calibration Date
AM1DV3 - 3082	February 16, 2023	DAE4 Sn1291	March 17, 2023

Communication Systems

Band Name	Communication Systems Name	Channel	Frequency [MHz]
Band 5, E-UTRA/FDD	LTE-FDD (SC-FDMA, 1 RB, 10 MHz, QPSK)	20525	836.5

Grid Settings

Extent X [mm]	Extent Y [mm]	Step X [mm]	Step Y [mm]	Distance [mm]
52.0	52.0	4.0	4.0	10.0

Results

Audio File	Measurement Duration [s]	Gain [dB]	Hmax [dB(A/m)]
48k_voice_1kHz_1s.wav	2.0	-12.37	-6.24

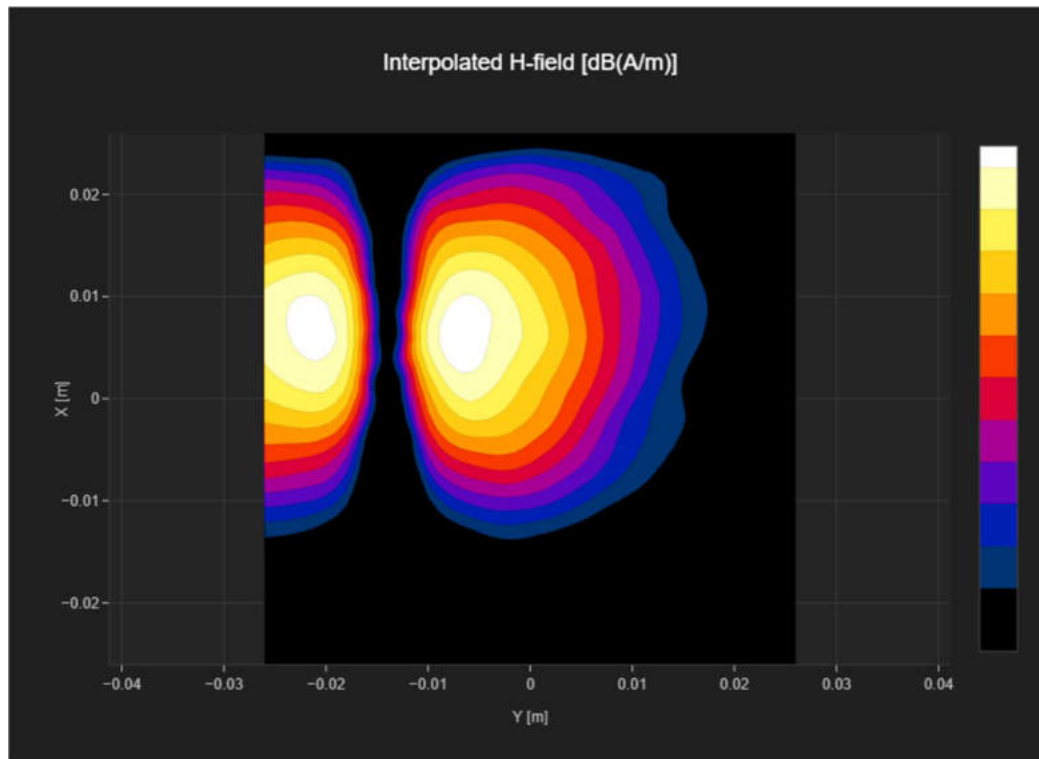

T-Coil Noise Test Report

Measurement performed on January 22, 2024 at 20:15

Device Under Test

Manufacturer	Model	Dimensions [mm]	Speaker Position [mm]
		146.2 x 71.8 x 7.5	144.3

Hardware Setup

Probe Name	Probe Calibration Date	DAE Name	DAE Calibration Date
AM1DV3 - 3082	February 16, 2023	DAE4 Sn1291	March 17, 2023

Communication Systems

Band Name	Communication Systems Name	Channel	Frequency [MHz]
Band 5, E-UTRA/FDD	LTE-FDD (SC-FDMA, 1 RB, 10 MHz, QPSK)	20525	836.5

Grid Settings

Extent X [mm]	Extent Y [mm]	Step X [mm]	Step Y [mm]	Distance [mm]
52.0	52.0	4.0	4.0	10.0

Results

Secondary Group Point Count	Secondary Group Max Longitudinal	Secondary Group Max Transverse	Hmax [dB(A/m)]
676	26	26	-39.63

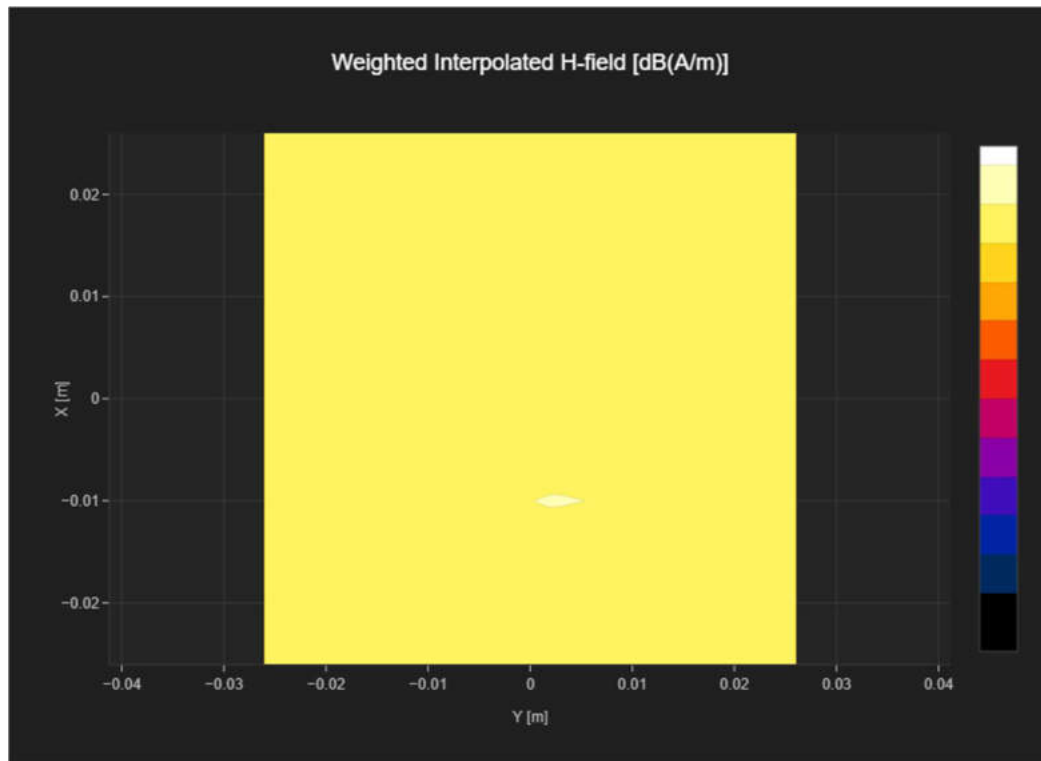

T-Coil Signal Test Report

Measurement performed on January 29, 2024 at 16:54

Device Under Test

Manufacturer	Model	Dimensions [mm]	Speaker Position [mm]
		146.2 x 71.8 x 7.5	144.3

Hardware Setup

Probe Name	Probe Calibration Date	DAE Name	DAE Calibration Date
AM1DV3 - 3082	February 16, 2023	DAE4 Sn1291	March 17, 2023

Communication Systems

Band Name	Communication Systems Name	Channel	Frequency [MHz]
Band 5, E-UTRA/FDD	LTE-FDD (SC-FDMA, 1 RB, 10 MHz, QPSK)	20525	836.5

Grid Settings

Extent X [mm]	Extent Y [mm]	Step X [mm]	Step Y [mm]	Distance [mm]
52.0	52.0	4.0	4.0	10.0

Results

Audio File	Measurement Duration [s]	Margin Upper Bound [dB]	Margin Lower Bound [dB]
48k_voice_300-3000_2s.wav	2.0	1.15	2.0

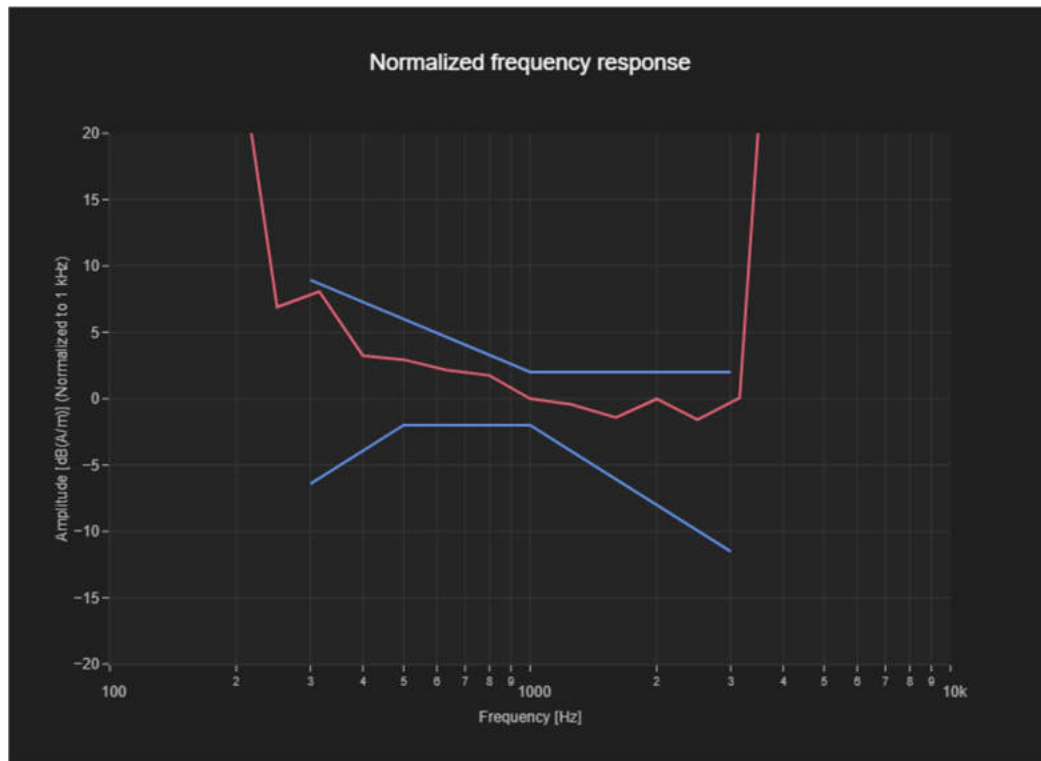

T-Coil Coupling Mode Test Report

Results

Primary Group Contiguous Point Count	Secondary Group Point Count	Secondary Group Max Longitudinal	Secondary Group Max Transverse
170	676	26	26



Plot 9 T-Coil LTE FDD Band 12

T-Coil Signal Test Report

Measurement performed on January 29, 2024 at 17:20

Device Under Test

Manufacturer	Model	Dimensions [mm]	Speaker Position [mm]
		146.2 x 71.8 x 7.5	144.3

Hardware Setup

Probe Name	Probe Calibration Date	DAE Name	DAE Calibration Date
AM1DV3 - 3082	February 16, 2023	DAE4 Sn1291	March 17, 2023

Communication Systems

Band Name	Communication Systems Name	Channel	Frequency [MHz]
Band 12, E-UTRA/FDD	LTE-FDD (SC-FDMA, 1 RB, 10 MHz, QPSK)	23095	707.5

Grid Settings

Extent X [mm]	Extent Y [mm]	Step X [mm]	Step Y [mm]	Distance [mm]
52.0	52.0	4.0	4.0	10.0

Results

Audio File	Measurement Duration [s]	Gain [dB]	Hmax [dB(A/m)]
48k_voice_1kHz_1s.wav	2.0	-12.37	-8.76

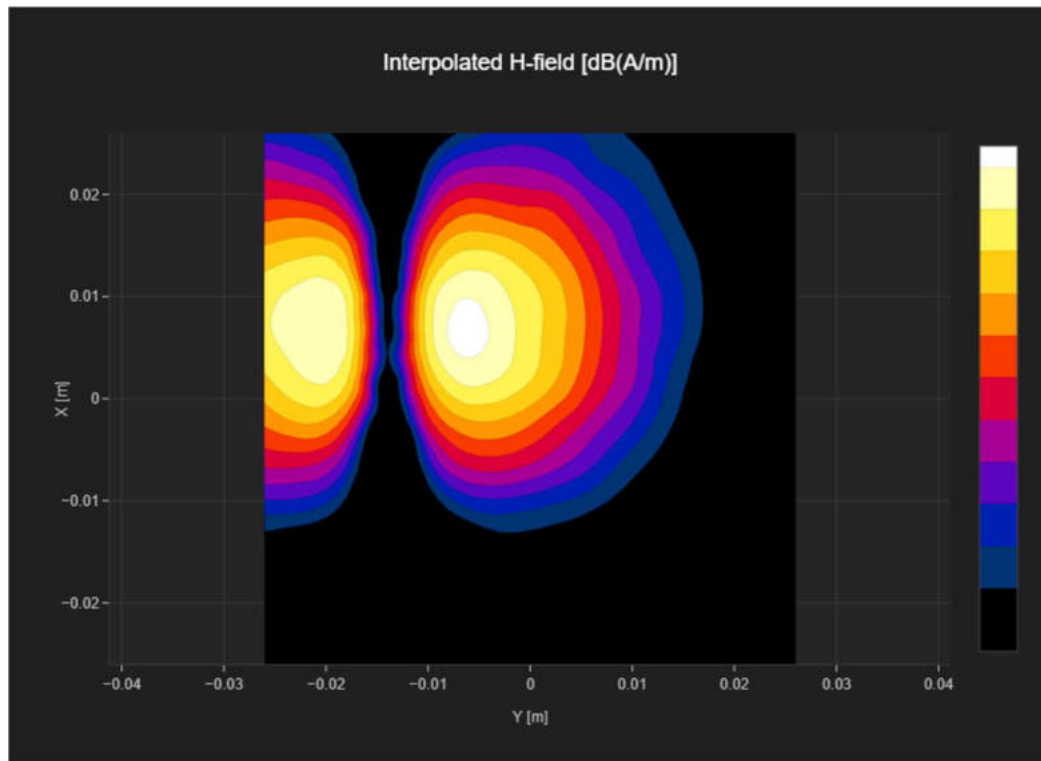

T-Coil Noise Test Report

Measurement performed on January 29, 2024 at 13:45

Device Under Test

Manufacturer	Model	Dimensions [mm]	Speaker Position [mm]
		146.2 x 71.8 x 7.5	144.3

Hardware Setup

Probe Name	Probe Calibration Date	DAE Name	DAE Calibration Date
AM1DV3 - 3082	February 16, 2023	DAE4 Sn1291	March 17, 2023

Communication Systems

Band Name	Communication Systems Name	Channel	Frequency [MHz]
Band 12, E-UTRA/FDD	LTE-FDD (SC-FDMA, 1 RB, 10 MHz, QPSK)	23095	707.5

Grid Settings

Extent X [mm]	Extent Y [mm]	Step X [mm]	Step Y [mm]	Distance [mm]
52.0	52.0	4.0	4.0	10.0

Results

Secondary Group Point Count	Secondary Group Max Longitudinal	Secondary Group Max Transverse	Hmax [dB(A/m)]
676	26	26	-40.99

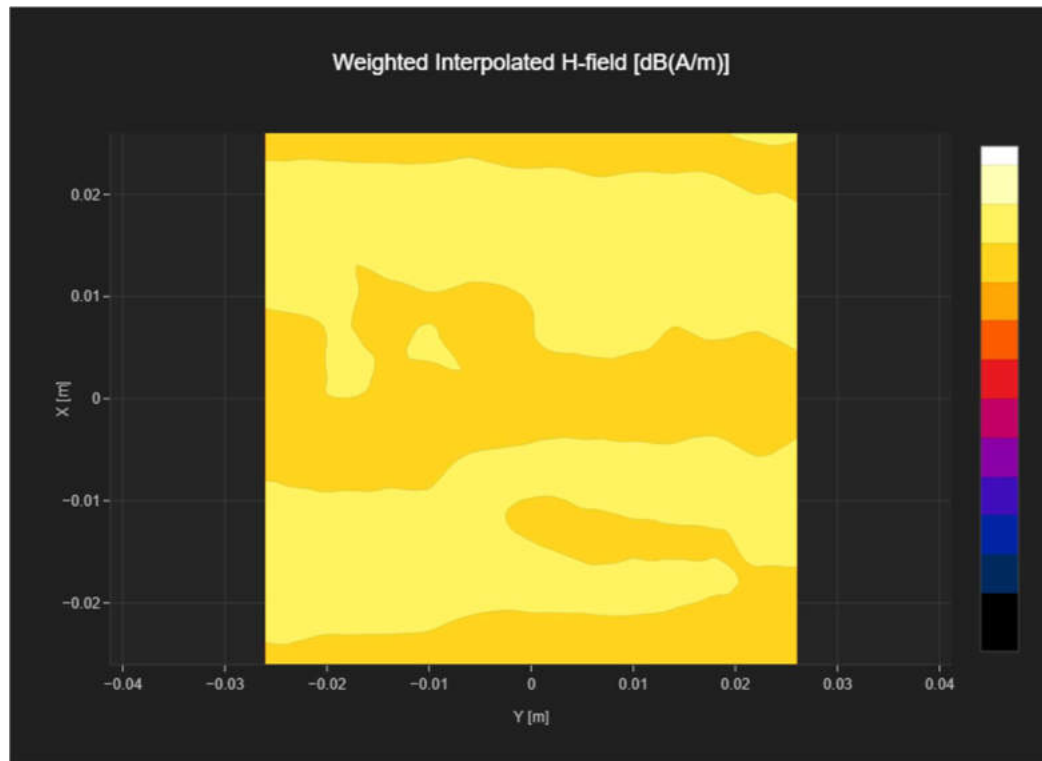

T-Coil Signal Test Report

Measurement performed on January 29, 2024 at 17:20

Device Under Test

Manufacturer	Model	Dimensions [mm]	Speaker Position [mm]
		146.2 x 71.8 x 7.5	144.3

Hardware Setup

Probe Name	Probe Calibration Date	DAE Name	DAE Calibration Date
AM1DV3 - 3082	February 16, 2023	DAE4 Sn1291	March 17, 2023

Communication Systems

Band Name	Communication Systems Name	Channel	Frequency [MHz]
Band 12, E-UTRA/FDD	LTE-FDD (SC-FDMA, 1 RB, 10 MHz, QPSK)	23095	707.5

Grid Settings

Extent X [mm]	Extent Y [mm]	Step X [mm]	Step Y [mm]	Distance [mm]
52.0	52.0	4.0	4.0	10.0

Results

Audio File	Measurement Duration [s]	Margin Upper Bound [dB]	Margin Lower Bound [dB]
48k_voice_300-3000_2s.wav	2.0	1.51	2.0

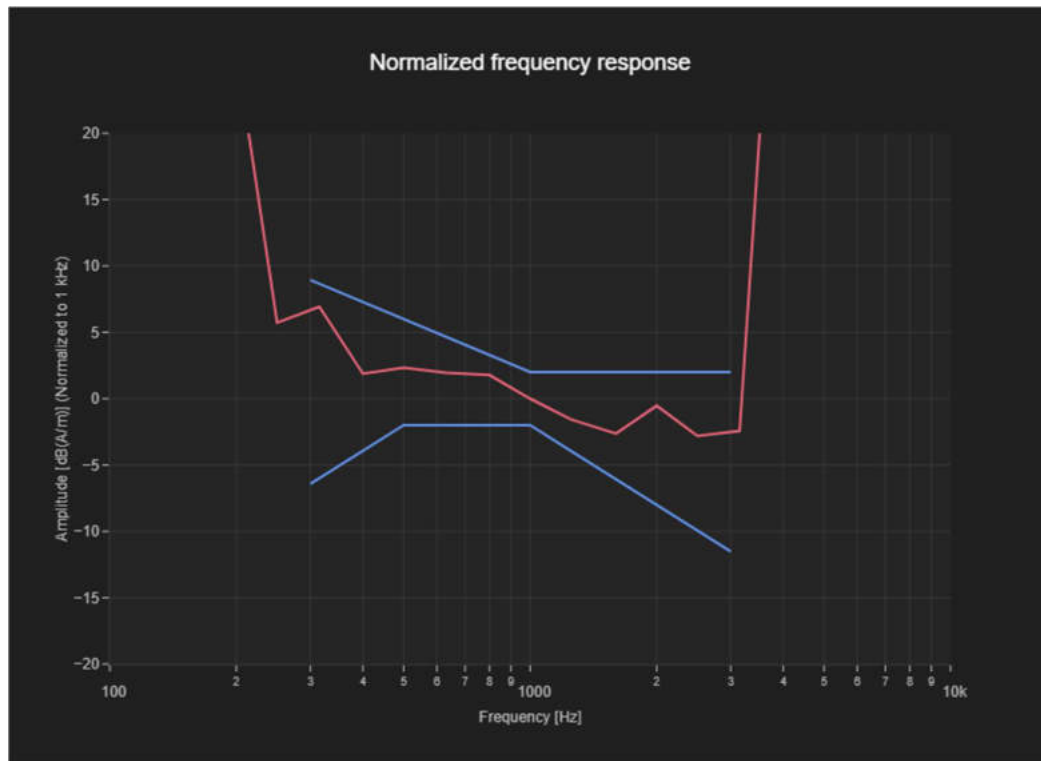

T-Coil Coupling Mode Test Report

Results

Primary Group Contiguous Point Count	Secondary Group Point Count	Secondary Group Max Longitudinal	Secondary Group Max Transverse
149	676	26	26



Plot 10 T-Coil LTE FDD Band 12 (Second Supply)
T-Coil Signal Test Report

Measurement performed on January 30, 2024 at 11:29

Device Under Test

Manufacturer	Model	Dimensions [mm]	Speaker Position [mm]
		146.2 x 71.8 x 7.5	144.3

Hardware Setup

Probe Name	Probe Calibration Date	DAE Name	DAE Calibration Date
AM1DV3 - 3082	February 16, 2023	DAE4 Sn1291	March 17, 2023

Communication Systems

Band Name	Communication Systems Name	Channel	Frequency [MHz]
Band 12, E-UTRA/FDD	LTE-FDD (SC-FDMA, 1 RB, 10 MHz, QPSK)	23095	707.5

Grid Settings

Extent X [mm]	Extent Y [mm]	Step X [mm]	Step Y [mm]	Distance [mm]
52.0	52.0	4.0	4.0	10.0

Results

Audio File	Measurement Duration [s]	Gain [dB]	Hmax [dB(A/m)]
48k_voice_1kHz_1s.wav	2.0	-12.35	-5.25

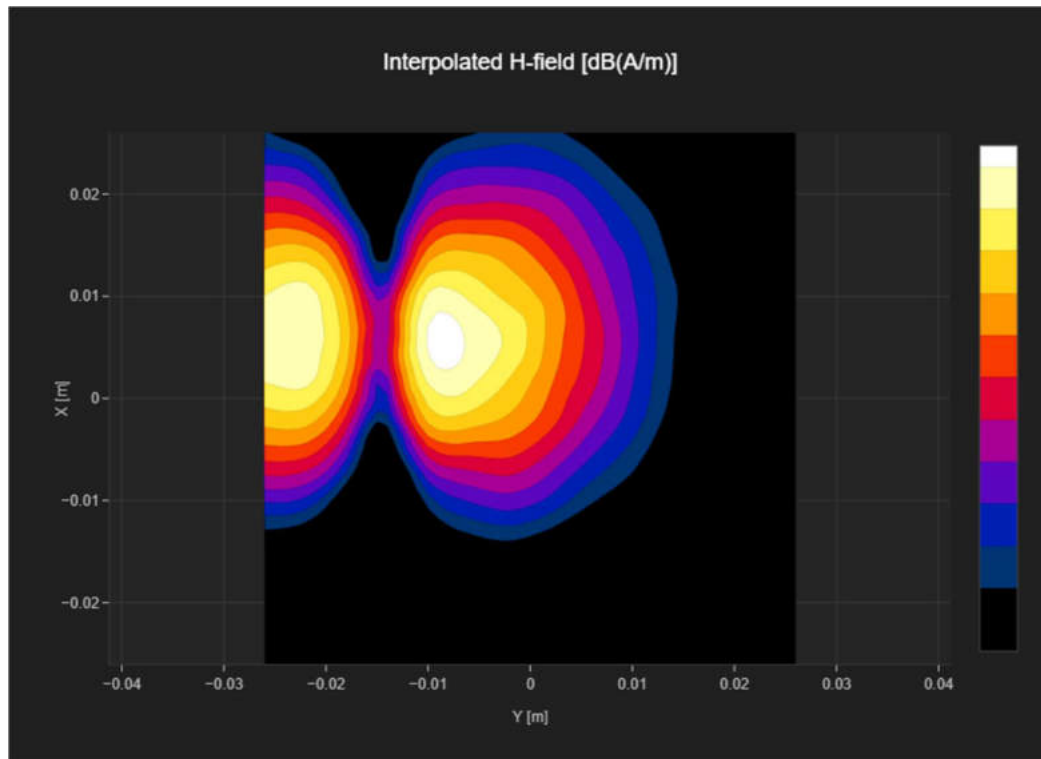

T-Coil Noise Test Report

Measurement performed on January 30, 2024 at 11:44

Device Under Test

Manufacturer	Model	Dimensions [mm]	Speaker Position [mm]
		146.2 x 71.8 x 7.5	144.3

Hardware Setup

Probe Name	Probe Calibration Date	DAE Name	DAE Calibration Date
AM1DV3 - 3082	February 16, 2023	DAE4 Sn1291	March 17, 2023

Communication Systems

Band Name	Communication Systems Name	Channel	Frequency [MHz]
Band 12, E-UTRA/FDD	LTE-FDD (SC-FDMA, 1 RB, 10 MHz, QPSK)	23095	707.5

Grid Settings

Extent X [mm]	Extent Y [mm]	Step X [mm]	Step Y [mm]	Distance [mm]
52.0	52.0	4.0	4.0	10.0

Results

Secondary Group Point Count	Secondary Group Max Longitudinal	Secondary Group Max Transverse	Hmax [dB(A/m)]
676	26	26	-39.6

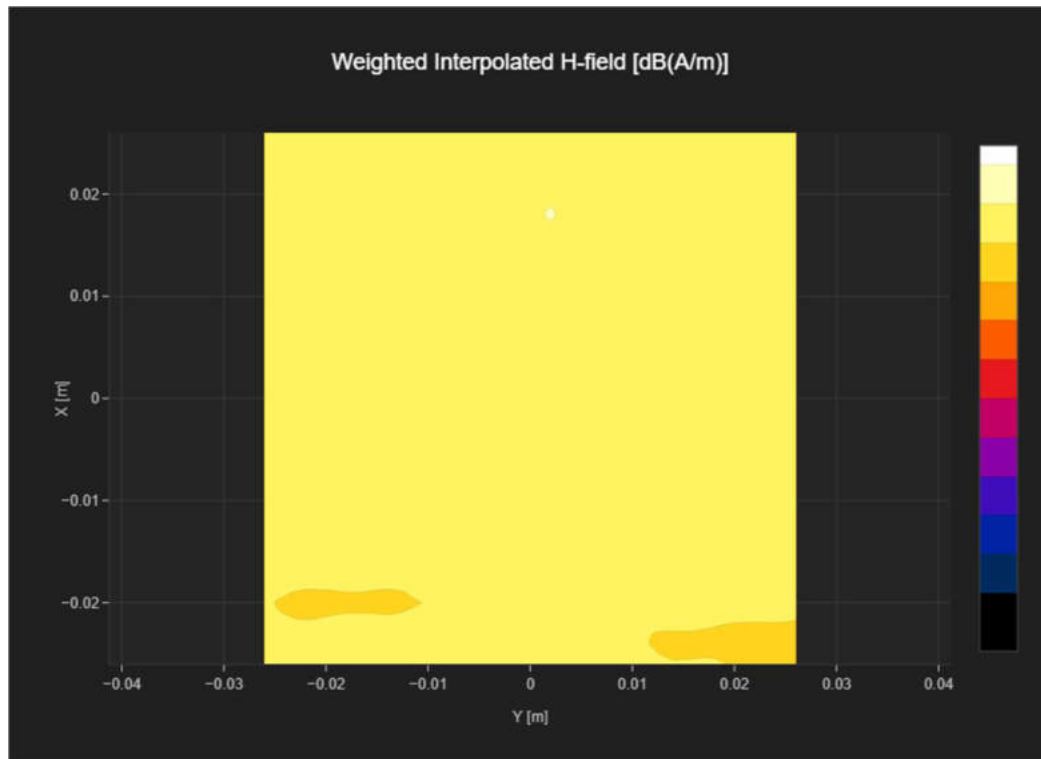

T-Coil Signal Test Report

Measurement performed on January 30, 2024 at 11:29

Device Under Test

Manufacturer	Model	Dimensions [mm]	Speaker Position [mm]
		146.2 x 71.8 x 7.5	144.3

Hardware Setup

Probe Name	Probe Calibration Date	DAE Name	DAE Calibration Date
AM1DV3 - 3082	February 16, 2023	DAE4 Sn1291	March 17, 2023

Communication Systems

Band Name	Communication Systems Name	Channel	Frequency [MHz]
Band 12, E-UTRA/FDD	LTE-FDD (SC-FDMA, 1 RB, 10 MHz, QPSK)	23095	707.5

Grid Settings

Extent X [mm]	Extent Y [mm]	Step X [mm]	Step Y [mm]	Distance [mm]
52.0	52.0	4.0	4.0	10.0

Results

Audio File	Measurement Duration [s]	Margin Upper Bound [dB]	Margin Lower Bound [dB]
48k_voice_300-3000_2s.wav	2.0	1.93	2.0

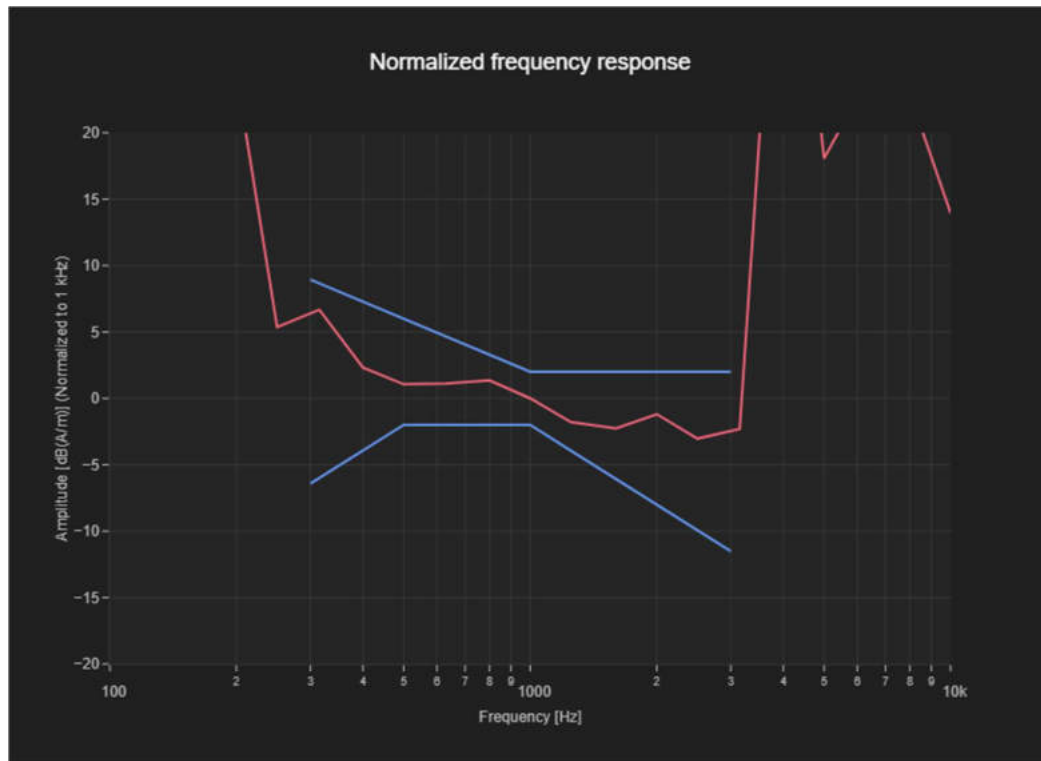

T-Coil Coupling Mode Test Report

Results

Primary Group Contiguous Point Count	Secondary Group Point Count	Secondary Group Max Longitudinal	Secondary Group Max Transverse
201	676	26	26

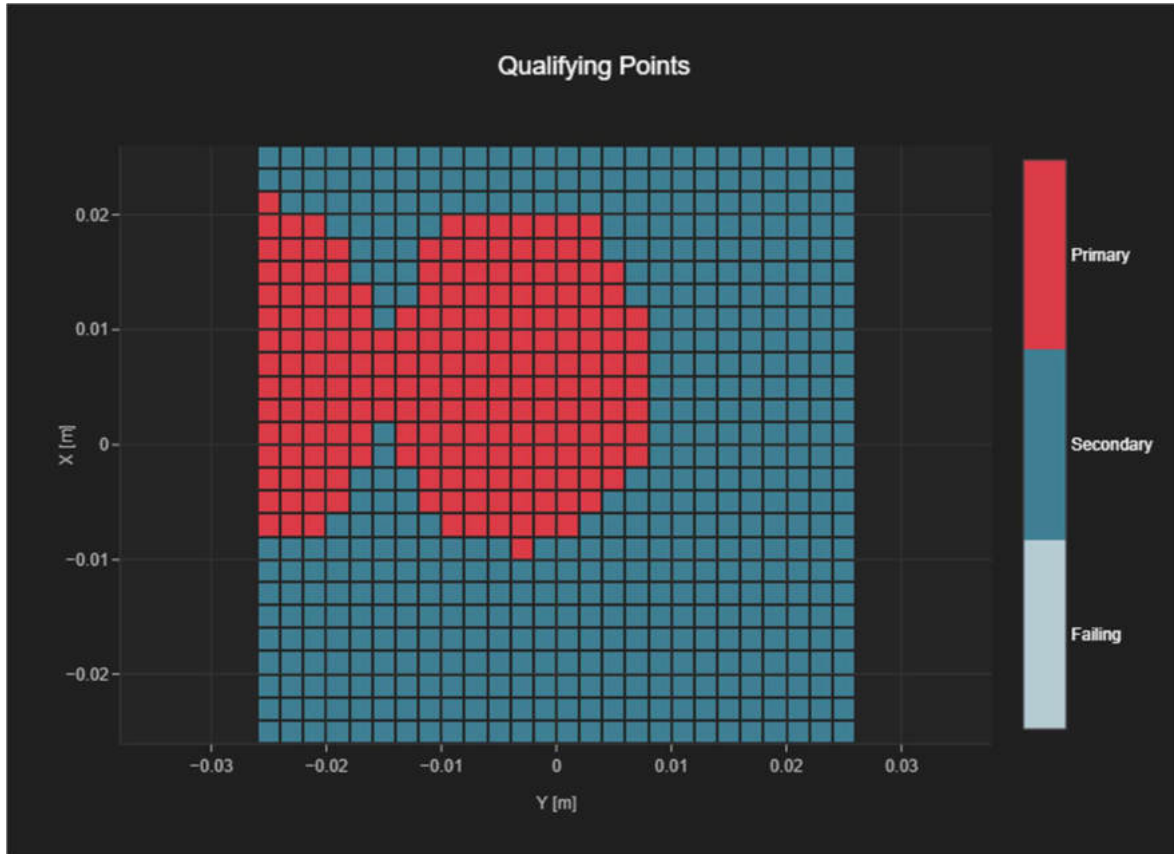

Plot 11 T-Coil LTE FDD Band 13

T-Coil Signal Test Report

Measurement performed on January 29, 2024 at 17:49

Device Under Test

Manufacturer	Model	Dimensions [mm]	Speaker Position [mm]
		146.2 x 71.8 x 7.5	144.3

Hardware Setup

Probe Name	Probe Calibration Date	DAE Name	DAE Calibration Date
AM1DV3 - 3082	February 16, 2023	DAE4 Sn1291	March 17, 2023

Communication Systems

Band Name	Communication Systems Name	Channel	Frequency [MHz]
Band 13, E-UTRA/FDD	LTE-FDD (SC-FDMA, 1 RB, 10 MHz, QPSK)	23230	782.0

Grid Settings

Extent X [mm]	Extent Y [mm]	Step X [mm]	Step Y [mm]	Distance [mm]
52.0	52.0	4.0	4.0	10.0

Results

Audio File	Measurement Duration [s]	Gain [dB]	Hmax [dB(A/m)]
48k_voice_1kHz_1s.wav	2.0	-12.37	-9.18

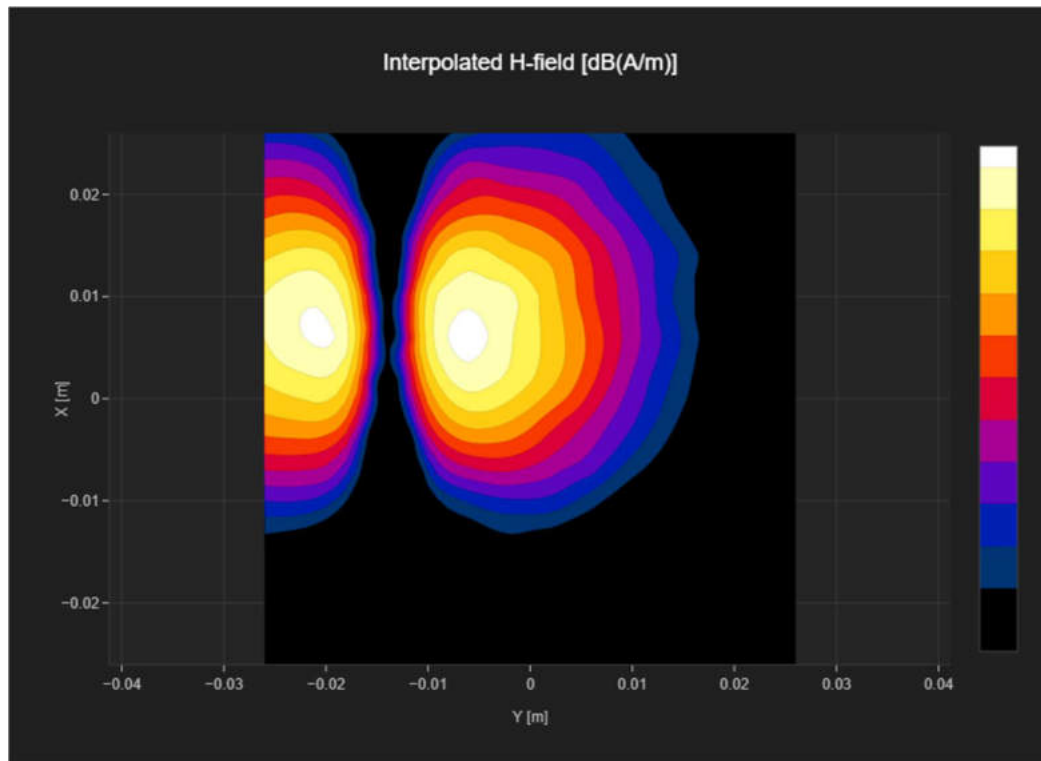

T-Coil Noise Test Report

Measurement performed on January 23, 2024 at 00:57

Device Under Test

Manufacturer	Model	Dimensions [mm]	Speaker Position [mm]
		146.2 x 71.8 x 7.5	144.3

Hardware Setup

Probe Name	Probe Calibration Date	DAE Name	DAE Calibration Date
AM1DV3 - 3082	February 16, 2023	DAE4 Sn1291	January 29, 2023

Communication Systems

Band Name	Communication Systems Name	Channel	Frequency [MHz]
Band 13, E-UTRA/FDD	LTE-FDD (SC-FDMA, 1 RB, 10 MHz, QPSK)	23230	782.0

Grid Settings

Extent X [mm]	Extent Y [mm]	Step X [mm]	Step Y [mm]	Distance [mm]
52.0	52.0	4.0	4.0	10.0

Results

Secondary Group Point Count	Secondary Group Max Longitudinal	Secondary Group Max Transverse	Hmax [dB(A/m)]
676	26	26	-44.1

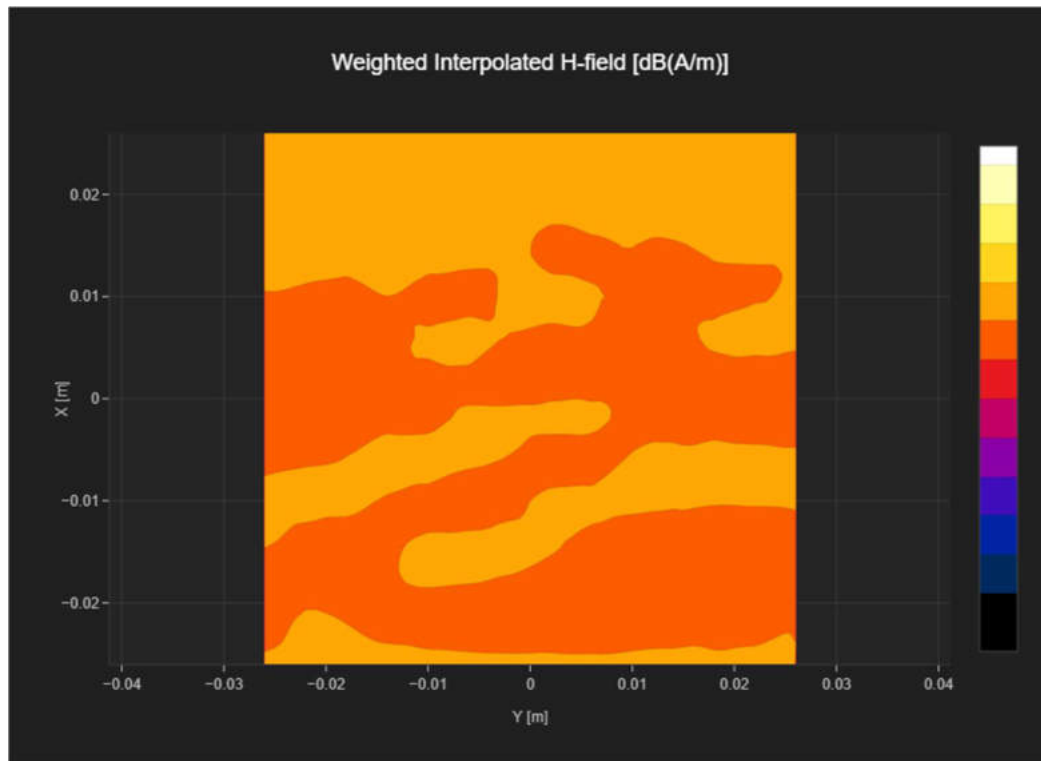

T-Coil Signal Test Report

Measurement performed on January 29, 2024 at 17:49

Device Under Test

Manufacturer	Model	Dimensions [mm]	Speaker Position [mm]
		146.2 x 71.8 x 7.5	144.3

Hardware Setup

Probe Name	Probe Calibration Date	DAE Name	DAE Calibration Date
AM1DV3 - 3082	February 16, 2023	DAE4 Sn1291	March 17, 2023

Communication Systems

Band Name	Communication Systems Name	Channel	Frequency [MHz]
Band 13, E-UTRA/FDD	LTE-FDD (SC-FDMA, 1 RB, 10 MHz, QPSK)	23230	782.0

Grid Settings

Extent X [mm]	Extent Y [mm]	Step X [mm]	Step Y [mm]	Distance [mm]
52.0	52.0	4.0	4.0	10.0

Results

Audio File	Measurement Duration [s]	Margin Upper Bound [dB]	Margin Lower Bound [dB]
48k_voice_300-3000_2s.wav	2.0	1.21	2.0

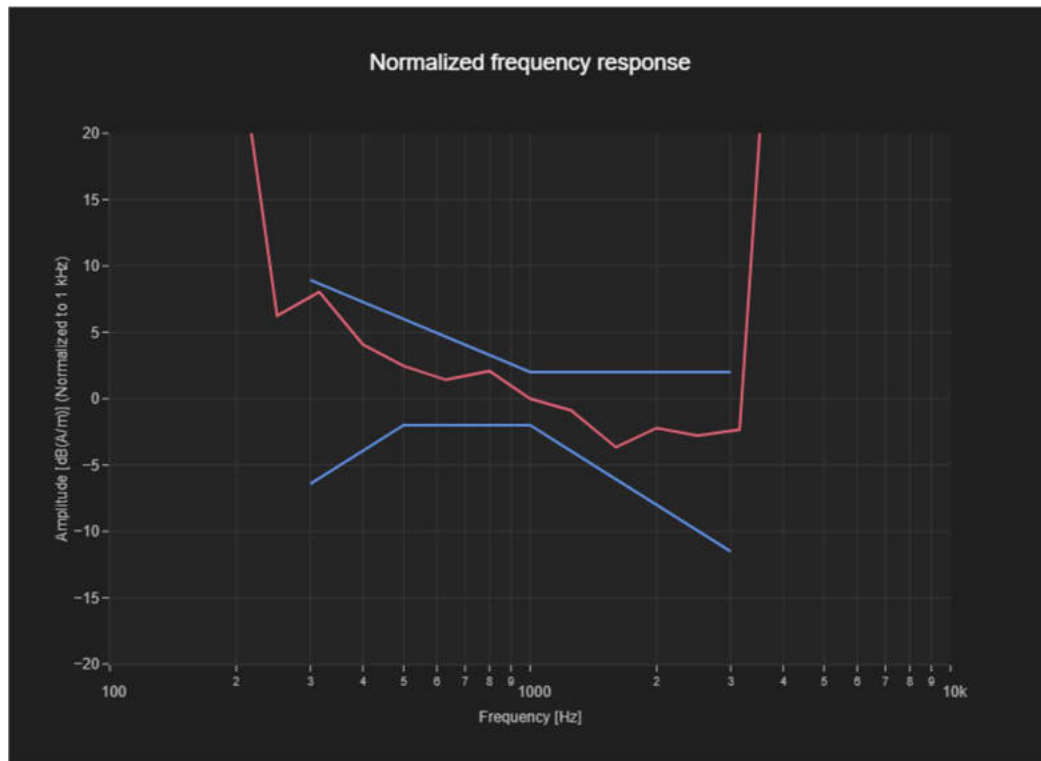

T-Coil Coupling Mode Test Report

Results

Primary Group Contiguous Point Count	Secondary Group Point Count	Secondary Group Max Longitudinal	Secondary Group Max Transverse
144	676	26	26

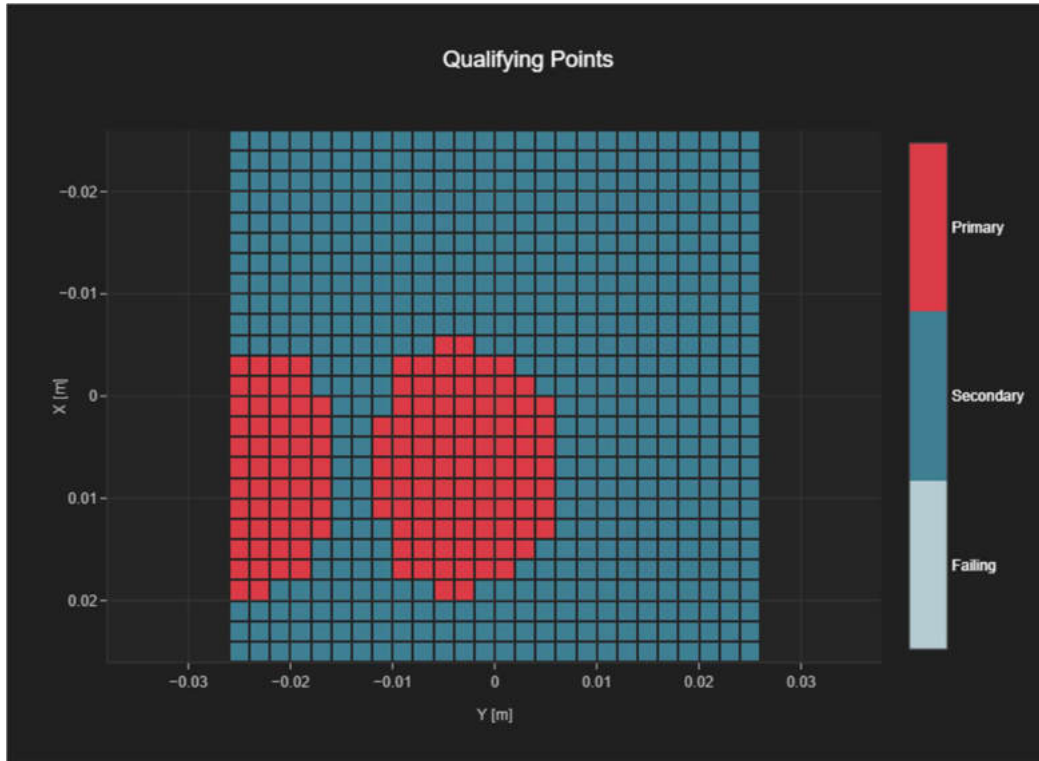

Plot 12 T-Coil LTE FDD Band 66

T-Coil Signal Test Report

Measurement performed on January 29, 2024 at 18:05

Device Under Test

Manufacturer	Model	Dimensions [mm]	Speaker Position [mm]
		146.2 x 71.8 x 7.5	144.3

Hardware Setup

Probe Name	Probe Calibration Date	DAE Name	DAE Calibration Date
AM1DV3 - 3082	February 16, 2023	DAE4 Sn1291	March 17, 2023

Communication Systems

Band Name	Communication Systems Name	Channel	Frequency [MHz]
Band 66, E-UTRA/FDD	LTE-FDD (SC-FDMA, 1 RB, 20 MHz, QPSK)	132322	1745.0

Grid Settings

Extent X [mm]	Extent Y [mm]	Step X [mm]	Step Y [mm]	Distance [mm]
52.0	52.0	4.0	4.0	10.0

Results

Audio File	Measurement Duration [s]	Gain [dB]	Hmax [dB(A/m)]
48k_voice_1kHz_1s.wav	2.0	-12.37	-8.82

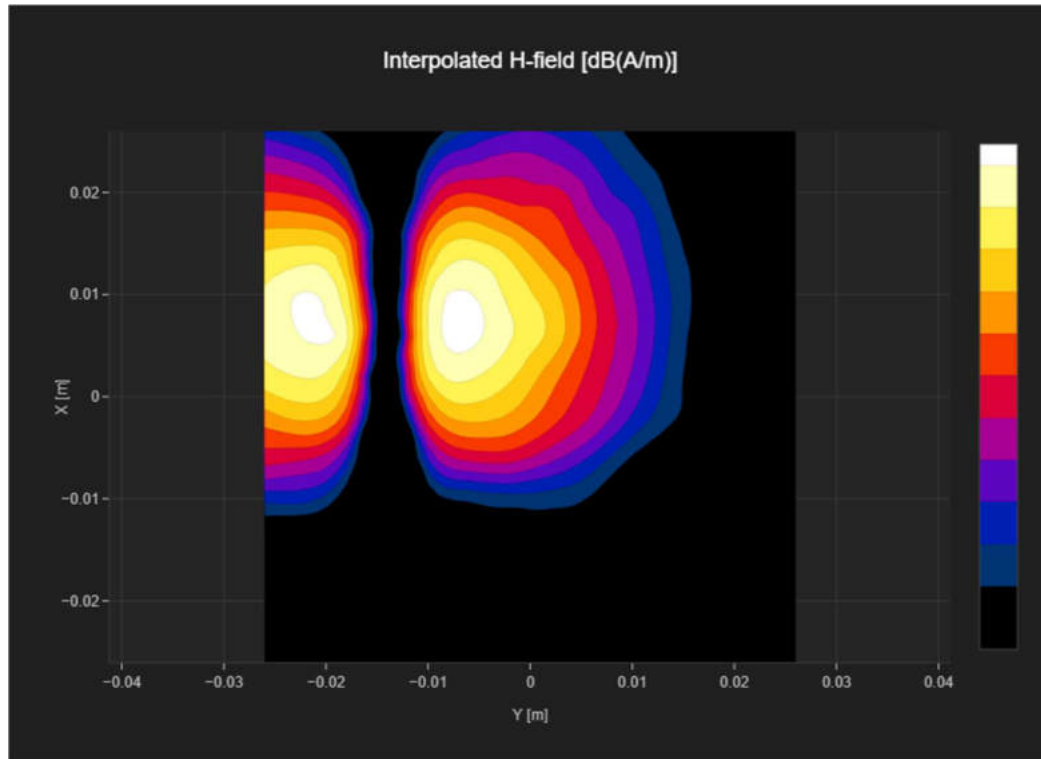

T-Coil Noise Test Report

Measurement performed on January 22, 2024 at 23:50

Device Under Test

Manufacturer	Model	Dimensions [mm]	Speaker Position [mm]
		146.2 x 71.8 x 7.5	144.3

Hardware Setup

Probe Name	Probe Calibration Date	DAE Name	DAE Calibration Date
AM1DV3 - 3082	February 16, 2023	DAE4 Sn1291	March 17, 2023

Communication Systems

Band Name	Communication Systems Name	Channel	Frequency [MHz]
Band 66, E-UTRA/FDD	LTE-FDD (SC-FDMA, 1 RB, 20 MHz, QPSK)	132322	1745.0

Grid Settings

Extent X [mm]	Extent Y [mm]	Step X [mm]	Step Y [mm]	Distance [mm]
52.0	52.0	4.0	4.0	10.0

Results

Secondary Group Point Count	Secondary Group Max Longitudinal	Secondary Group Max Transverse	Hmax [dB(A/m)]
676	26	26	-41.45

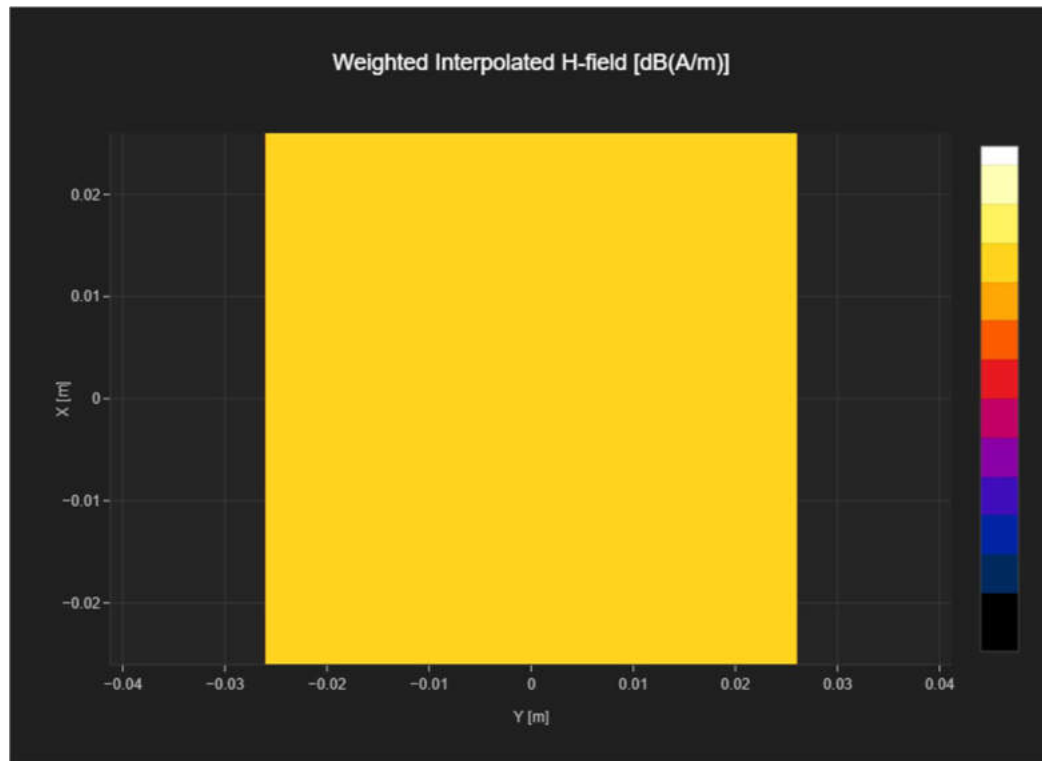

T-Coil Signal Test Report

Measurement performed on January 29, 2024 at 18:05

Device Under Test

Manufacturer	Model	Dimensions [mm]	Speaker Position [mm]
		146.2 x 71.8 x 7.5	144.3

Hardware Setup

Probe Name	Probe Calibration Date	DAE Name	DAE Calibration Date
AM1DV3 - 3082	February 16, 2023	DAE4 Sn1291	March 17, 2023

Communication Systems

Band Name	Communication Systems Name	Channel	Frequency [MHz]
Band 66, E-UTRA/FDD	LTE-FDD (SC-FDMA, 1 RB, 20 MHz, QPSK)	132322	1745.0

Grid Settings

Extent X [mm]	Extent Y [mm]	Step X [mm]	Step Y [mm]	Distance [mm]
52.0	52.0	4.0	4.0	10.0

Results

Audio File	Measurement Duration [s]	Margin Upper Bound [dB]	Margin Lower Bound [dB]
48k_voice_300-3000_2s.wav	2.0	1.11	2.0

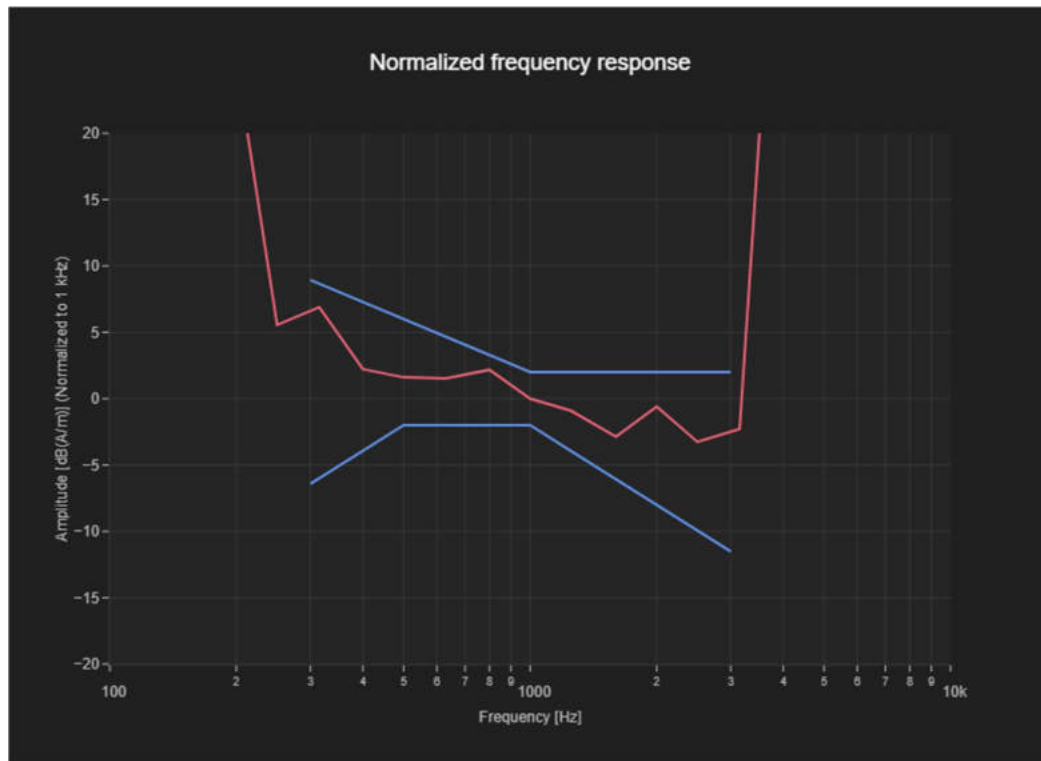

T-Coil Coupling Mode Test Report

Results

Primary Group Contiguous Point Count	Secondary Group Point Count	Secondary Group Max Longitudinal	Secondary Group Max Transverse
146	676	26	26



Plot 13 T-Coil WIFI2.4G: 802.11b

T-Coil Signal Test Report

Measurement performed on January 31, 2024 at 02:16

Device Under Test

Manufacturer	Model	Dimensions [mm]	Speaker Position [mm]
		146.2 x 71.8 x 7.5	144.3

Hardware Setup

Probe Name	Probe Calibration Date	DAE Name	DAE Calibration Date
AM1DV3 - 3082	February 16, 2023	DAE4 Sn1291	March 17, 2023

Communication Systems

Band Name	Communication Systems Name	Channel	Frequency [MHz]
WLAN 2.4GHz	IEEE 802.11b WiFi 2.4 GHz (DSSS, 1 Mbps)	6	2437.0

Grid Settings

Extent X [mm]	Extent Y [mm]	Step X [mm]	Step Y [mm]	Distance [mm]
52.0	52.0	4.0	4.0	10.0

Results

Audio File	Measurement Duration [s]	Gain [dB]	Hmax [dB(A/m)]
48k_voice_1kHz_1s.wav	2.0	-12.35	-5.8

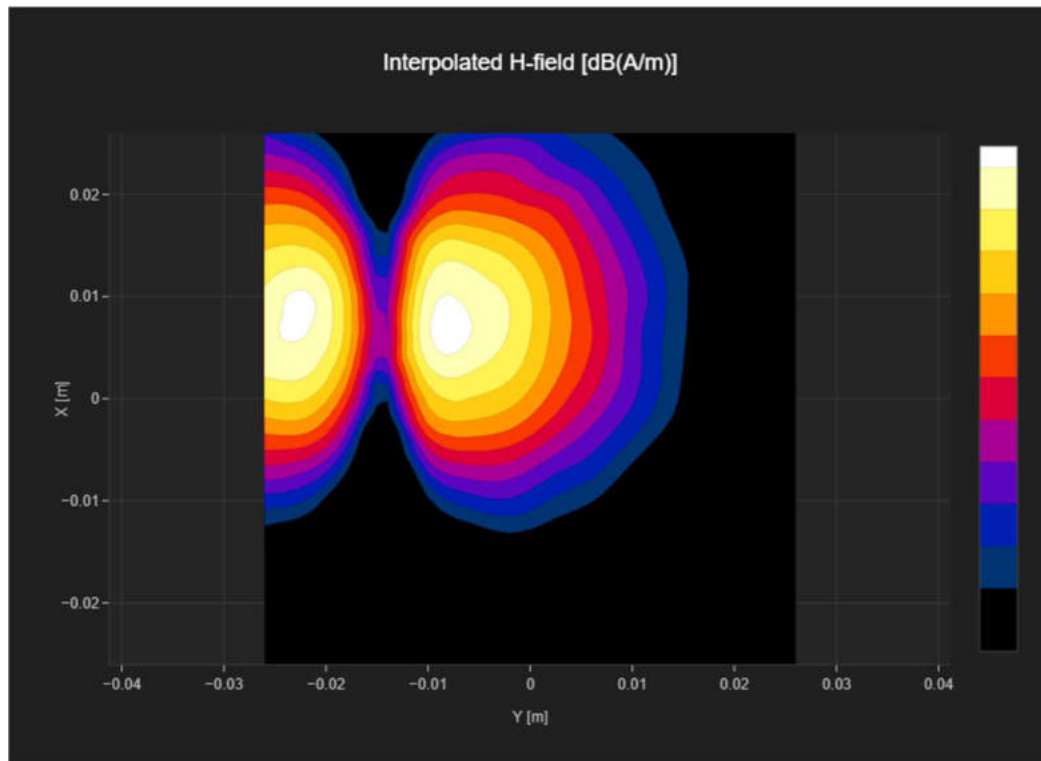

T-Coil Noise Test Report

Measurement performed on January 31, 2024 at 03:07

Device Under Test

Manufacturer	Model	Dimensions [mm]	Speaker Position [mm]
		146.2 x 71.8 x 7.5	144.3

Hardware Setup

Probe Name	Probe Calibration Date	DAE Name	DAE Calibration Date
AM1DV3 - 3082	February 16, 2023	DAE4 Sn1291	March 17, 2023

Communication Systems

Band Name	Communication Systems Name	Channel	Frequency [MHz]
WLAN 2.4GHz	IEEE 802.11b WiFi 2.4 GHz (DSSS, 1 Mbps)	6	2437.0

Grid Settings

Extent X [mm]	Extent Y [mm]	Step X [mm]	Step Y [mm]	Distance [mm]
52.0	52.0	4.0	4.0	10.0

Results

Secondary Group Point Count	Secondary Group Max Longitudinal	Secondary Group Max Transverse	Hmax [dB(A/m)]
676	26	26	-42.51

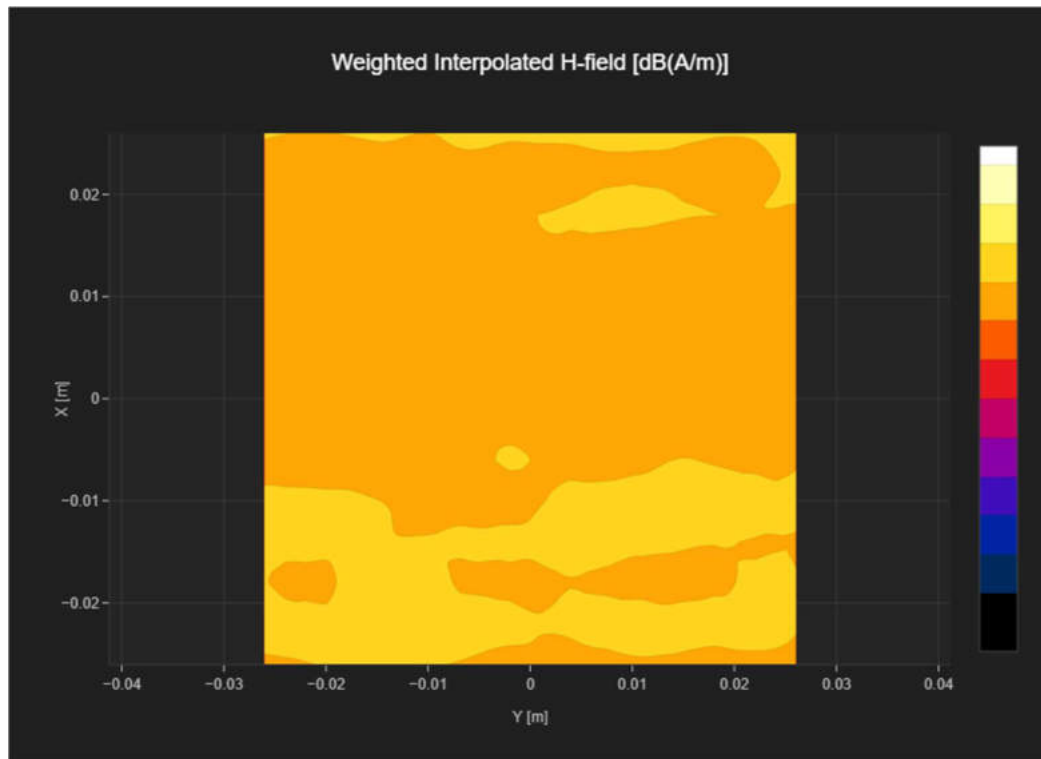

T-Coil Signal Test Report

Measurement performed on January 31, 2024 at 02:16

Device Under Test

Manufacturer	Model	Dimensions [mm]	Speaker Position [mm]
		146.2 x 71.8 x 7.5	144.3

Hardware Setup

Probe Name	Probe Calibration Date	DAE Name	DAE Calibration Date
AM1DV3 - 3082	February 16, 2023	DAE4 Sn1291	March 17, 2023

Communication Systems

Band Name	Communication Systems Name	Channel	Frequency [MHz]
WLAN 2.4GHz	IEEE 802.11b WiFi 2.4 GHz (DSSS, 1 Mbps)	6	2437.0

Grid Settings

Extent X [mm]	Extent Y [mm]	Step X [mm]	Step Y [mm]	Distance [mm]
52.0	52.0	4.0	4.0	10.0

Results

Audio File	Measurement Duration [s]	Margin Upper Bound [dB]	Margin Lower Bound [dB]
48k_voice_300-3000_2s.wav	2.0	1.38	2.0

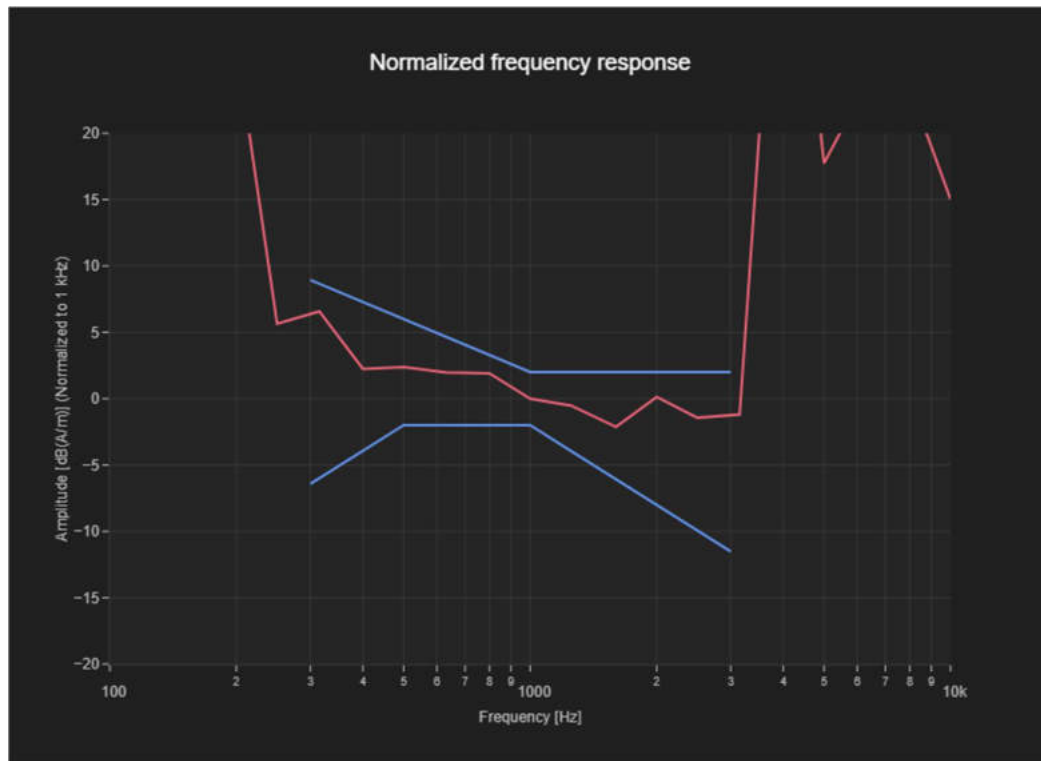

T-Coil Coupling Mode Test Report

Results

Primary Group Contiguous Point Count	Secondary Group Point Count	Secondary Group Max Longitudinal	Secondary Group Max Transverse
201	676	26	26



Plot 14 T-Coil WIFI2.4G: 802.11b (Second Supply)

T-Coil Signal Test Report

Measurement performed on January 31, 2024 at 14:09

Device Under Test

Manufacturer	Model	Dimensions [mm]	Speaker Position [mm]
		146.2 x 71.8 x 7.5	144.3

Hardware Setup

Probe Name	Probe Calibration Date	DAE Name	DAE Calibration Date
AM1DV3 - 3082	February 16, 2023	DAE4 Sn1291	March 17, 2023

Communication Systems

Band Name	Communication Systems Name	Channel	Frequency [MHz]
WLAN 2.4GHz	IEEE 802.11b WiFi 2.4 GHz (DSSS, 1 Mbps)	6	2437.0

Grid Settings

Extent X [mm]	Extent Y [mm]	Step X [mm]	Step Y [mm]	Distance [mm]
52.0	52.0	4.0	4.0	10.0

Results

Audio File	Measurement Duration [s]	Gain [dB]	Hmax [dB(A/m)]
48k_voice_1kHz_1s.wav	2.0	-12.35	-9.18

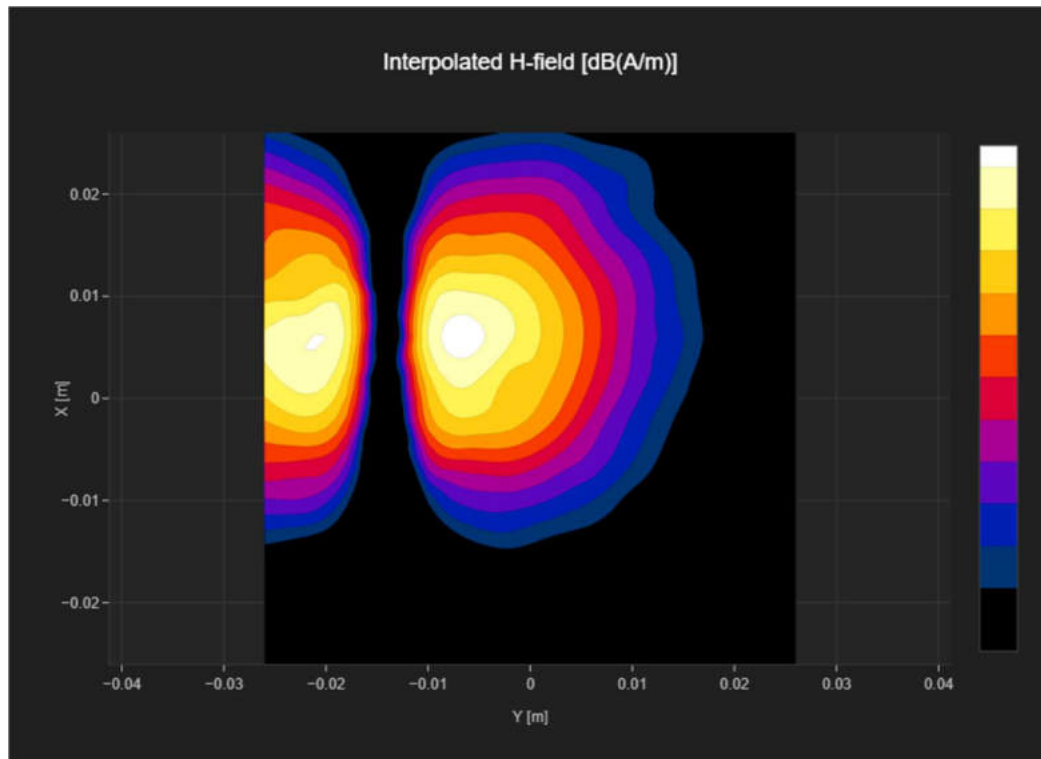

T-Coil Noise Test Report

Measurement performed on January 31, 2024 at 14:22

Device Under Test

Manufacturer	Model	Dimensions [mm]	Speaker Position [mm]
		146.2 x 71.8 x 7.5	144.3

Hardware Setup

Probe Name	Probe Calibration Date	DAE Name	DAE Calibration Date
AM1DV3 - 3082	February 16, 2023	DAE4 Sn1291	March 17, 2023

Communication Systems

Band Name	Communication Systems Name	Channel	Frequency [MHz]
WLAN 2.4GHz	IEEE 802.11b WiFi 2.4 GHz (DSSS, 1 Mbps)	6	2437.0

Grid Settings

Extent X [mm]	Extent Y [mm]	Step X [mm]	Step Y [mm]	Distance [mm]
52.0	52.0	4.0	4.0	10.0

Results

Secondary Group Point Count	Secondary Group Max Longitudinal	Secondary Group Max Transverse	Hmax [dB(A/m)]
676	26	26	-42.31

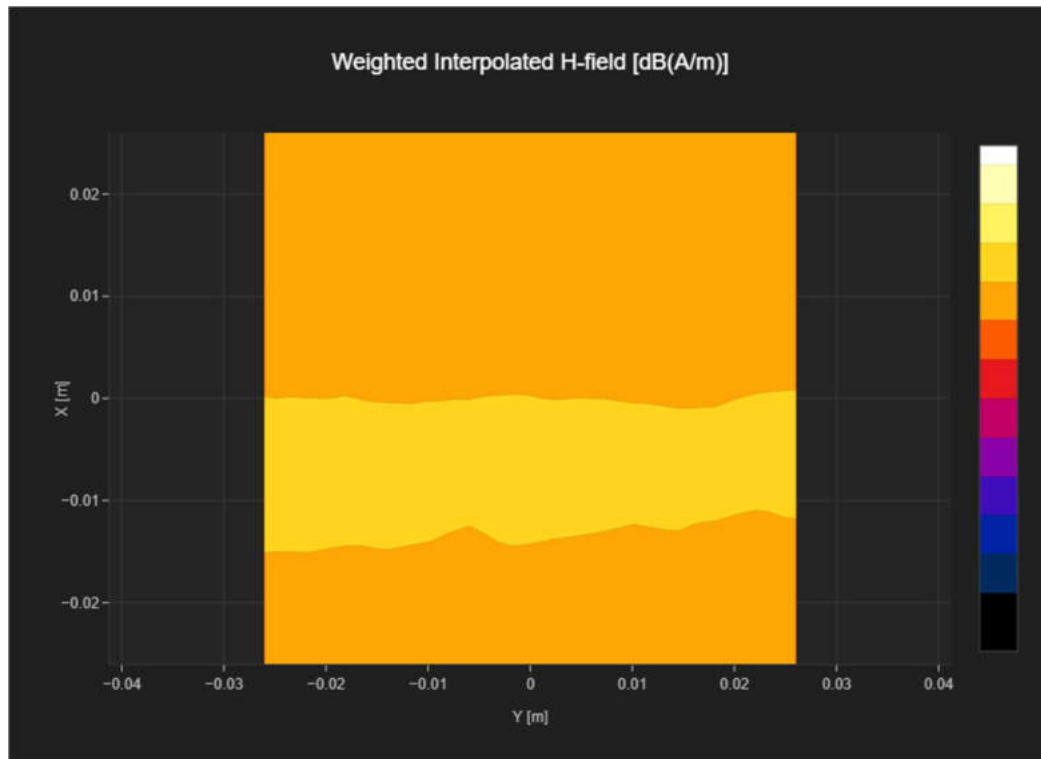

T-Coil Signal Test Report

Measurement performed on January 31, 2024 at 14:09

Device Under Test

Manufacturer	Model	Dimensions [mm]	Speaker Position [mm]
		146.2 x 71.8 x 7.5	144.3

Hardware Setup

Probe Name	Probe Calibration Date	DAE Name	DAE Calibration Date
AM1DV3 - 3082	February 16, 2023	DAE4 Sn1291	March 17, 2023

Communication Systems

Band Name	Communication Systems Name	Channel	Frequency [MHz]
WLAN 2.4GHz	IEEE 802.11b WiFi 2.4 GHz (DSSS, 1 Mbps)	6	2437.0

Grid Settings

Extent X [mm]	Extent Y [mm]	Step X [mm]	Step Y [mm]	Distance [mm]
52.0	52.0	4.0	4.0	10.0

Results

Audio File	Measurement Duration [s]	Margin Upper Bound [dB]	Margin Lower Bound [dB]
48k_voice_300-3000_2s.wav	2.0	0.88	2.0

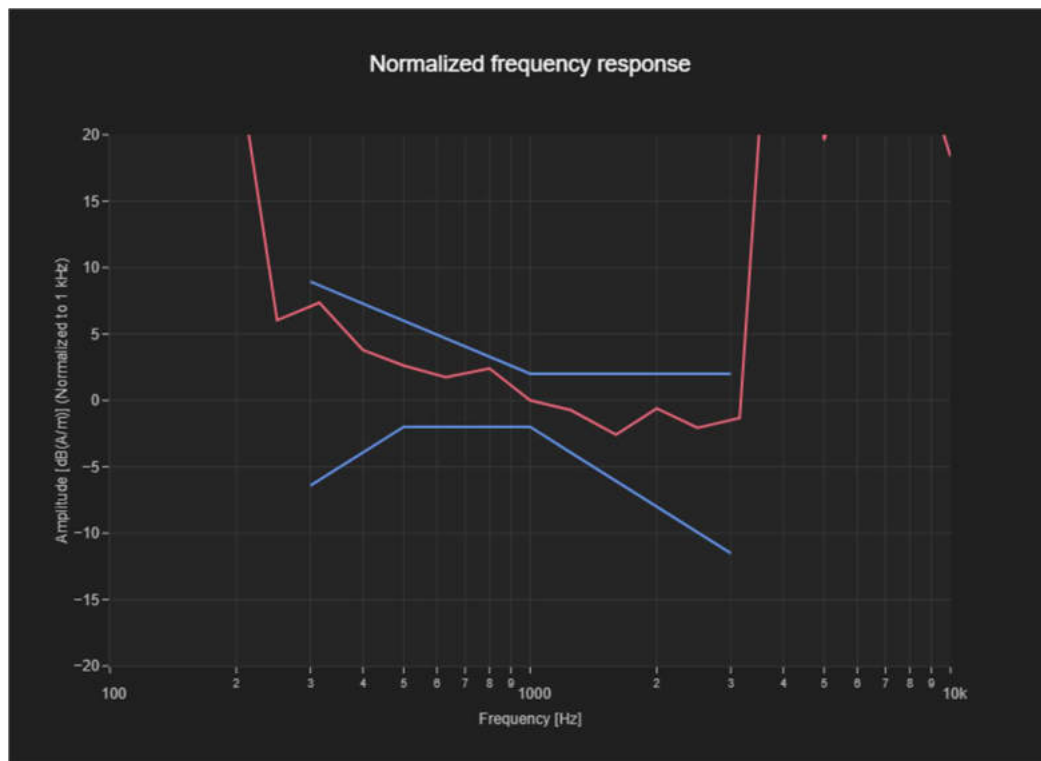

T-Coil Coupling Mode Test Report

Results

Primary Group Contiguous Point Count	Secondary Group Point Count	Secondary Group Max Longitudinal	Secondary Group Max Transverse
141	676	26	26



Plot 15 T-Coil WIFI 5G: 802.11a

T-Coil Signal Test Report

Measurement performed on January 31, 2024 at 09:31

Device Under Test

Manufacturer	Model	Dimensions [mm]	Speaker Position [mm]
		146.2 x 71.8 x 7.5	144.3

Hardware Setup

Probe Name	Probe Calibration Date	DAE Name	DAE Calibration Date
AM1DV3 - 3082	February 16, 2023	DAE4 Sn1291	March 17, 2023

Communication Systems

Band Name	Communication Systems Name	Channel	Frequency [MHz]
WLAN 5GHz	IEEE 802.11a WiFi 5 GHz (OFDM, 6 Mbps, 96pc duty cycle)	36	5180.0

Grid Settings

Extent X [mm]	Extent Y [mm]	Step X [mm]	Step Y [mm]	Distance [mm]
52.0	52.0	4.0	4.0	10.0

Results

Audio File	Measurement Duration [s]	Gain [dB]	Hmax [dB(A/m)]
48k_voice_1kHz_1s.wav	2.0	-12.35	-6.0

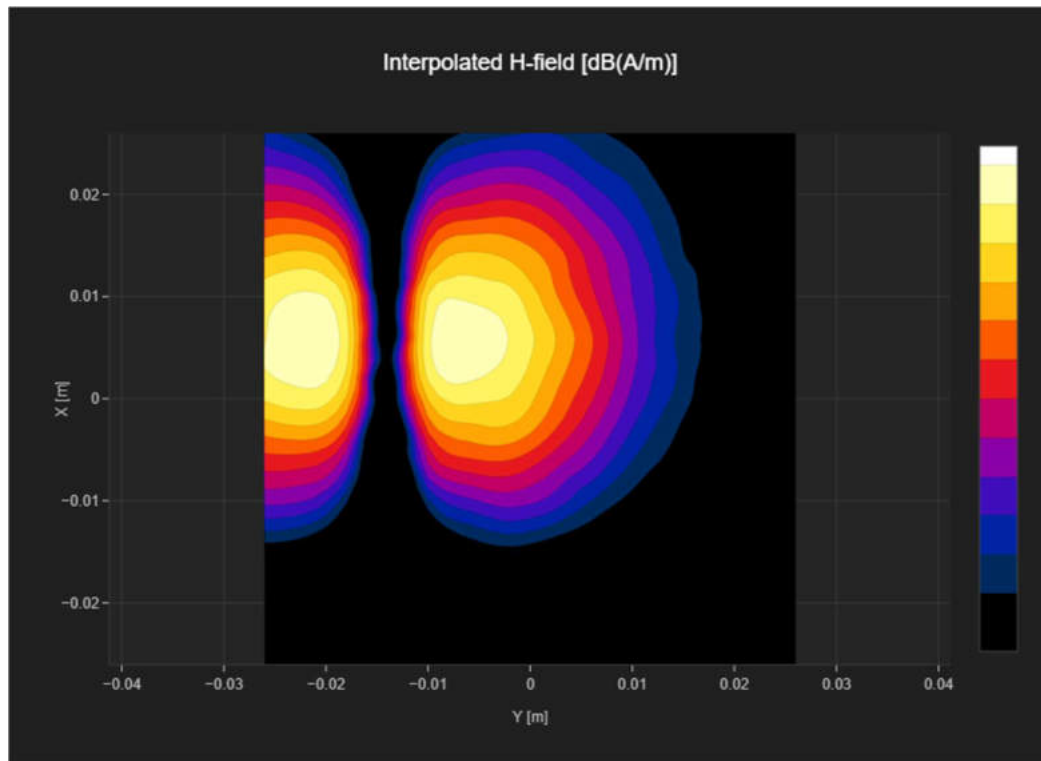

T-Coil Noise Test Report

Measurement performed on January 31, 2024 at 09:42

Device Under Test

Manufacturer	Model	Dimensions [mm]	Speaker Position [mm]
		146.2 x 71.8 x 7.5	144.3

Hardware Setup

Probe Name	Probe Calibration Date	DAE Name	DAE Calibration Date
AM1DV3 - 3082	February 16, 2023	DAE4 Sn1291	March 17, 2023

Communication Systems

Band Name	Communication Systems Name	Channel	Frequency [MHz]
WLAN 5GHz	IEEE 802.11a WiFi 5 GHz (OFDM, 6 Mbps, 96pc duty cycle)	36	5180.0

Grid Settings

Extent X [mm]	Extent Y [mm]	Step X [mm]	Step Y [mm]	Distance [mm]
52.0	52.0	4.0	4.0	10.0

Results

Secondary Group Point Count	Secondary Group Max Longitudinal	Secondary Group Max Transverse	Hmax [dB(A/m)]
676	26	26	-40.04

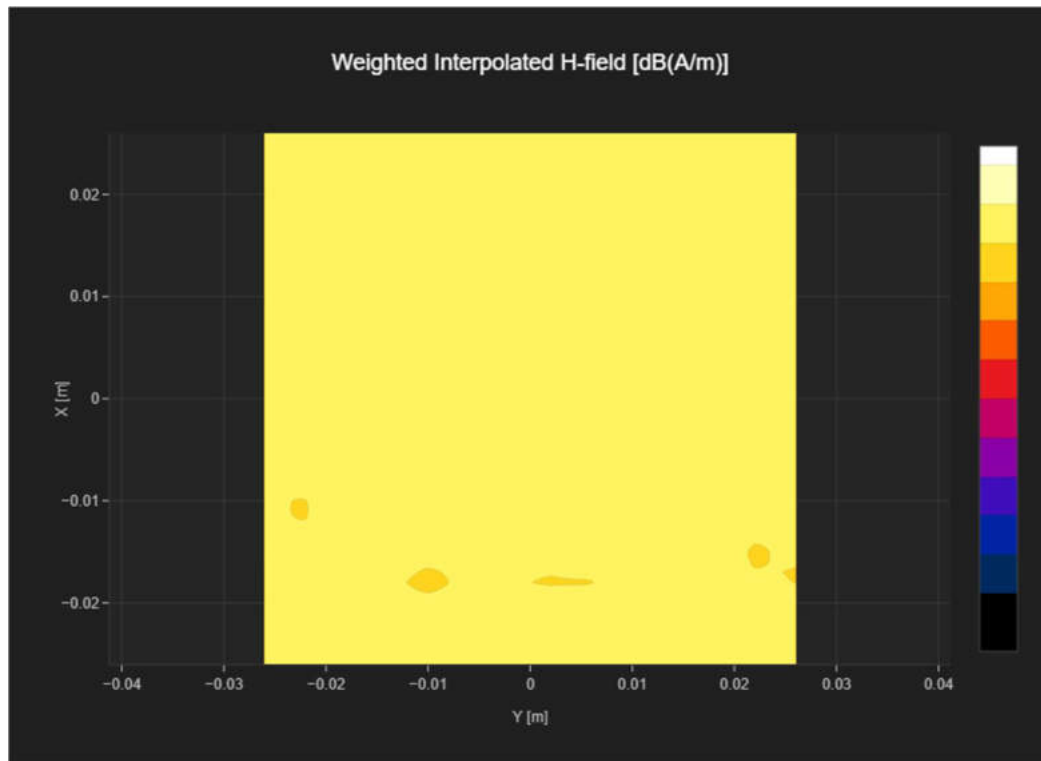

T-Coil Signal Test Report

Measurement performed on January 31, 2024 at 09:31

Device Under Test

Manufacturer	Model	Dimensions [mm]	Speaker Position [mm]
		146.2 x 71.8 x 7.5	144.3

Hardware Setup

Probe Name	Probe Calibration Date	DAE Name	DAE Calibration Date
AM1DV3 - 3082	February 16, 2023	DAE4 Sn1291	March 17, 2023

Communication Systems

Band Name	Communication Systems Name	Channel	Frequency [MHz]
WLAN 5GHz	IEEE 802.11a WiFi 5 GHz (OFDM, 6 Mbps, 96pc duty cycle)	36	5180.0

Grid Settings

Extent X [mm]	Extent Y [mm]	Step X [mm]	Step Y [mm]	Distance [mm]
52.0	52.0	4.0	4.0	10.0

Results

Audio File	Measurement Duration [s]	Margin Upper Bound [dB]	Margin Lower Bound [dB]
48k_voice_300-3000_2s.wav	2.0	0.18	2.0

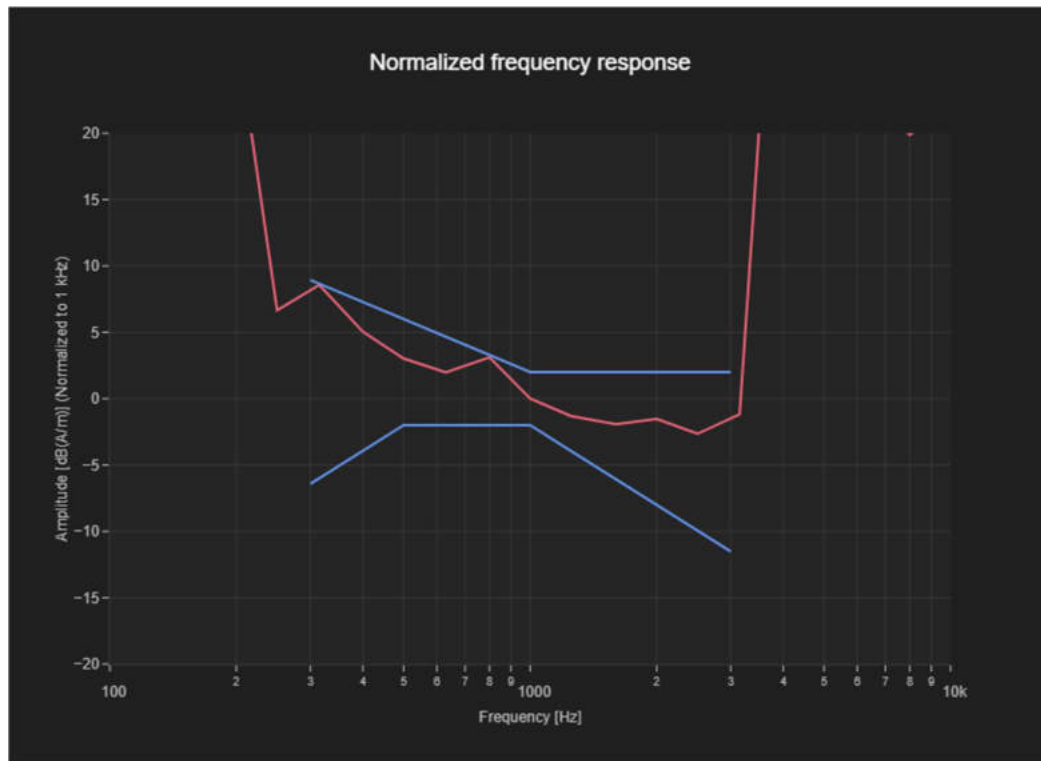

T-Coil Coupling Mode Test Report

Results

Primary Group Contiguous Point Count	Secondary Group Point Count	Secondary Group Max Longitudinal	Secondary Group Max Transverse
206	676	26	26



Plot 16 T-Coil WIFI 5G: 802.11a (Second Supply)
T-Coil Signal Test Report

Measurement performed on January 31, 2024 at 14:54

Device Under Test

Manufacturer	Model	Dimensions [mm]	Speaker Position [mm]
		146.2 x 71.8 x 7.5	144.3

Hardware Setup

Probe Name	Probe Calibration Date	DAE Name	DAE Calibration Date
AM1DV3 - 3082	February 16, 2023	DAE4 Sn1291	March 17, 2023

Communication Systems

Band Name	Communication Systems Name	Channel	Frequency [MHz]
WLAN 5GHz	IEEE 802.11a/h WiFi 5 GHz (OFDM, 6 Mbps)	36	5180.0

Grid Settings

Extent X [mm]	Extent Y [mm]	Step X [mm]	Step Y [mm]	Distance [mm]
52.0	52.0	4.0	4.0	10.0

Results

Audio File	Measurement Duration [s]	Gain [dB]	Hmax [dB(A/m)]
48k_voice_1kHz_1s.wav	2.0	-12.35	-8.18

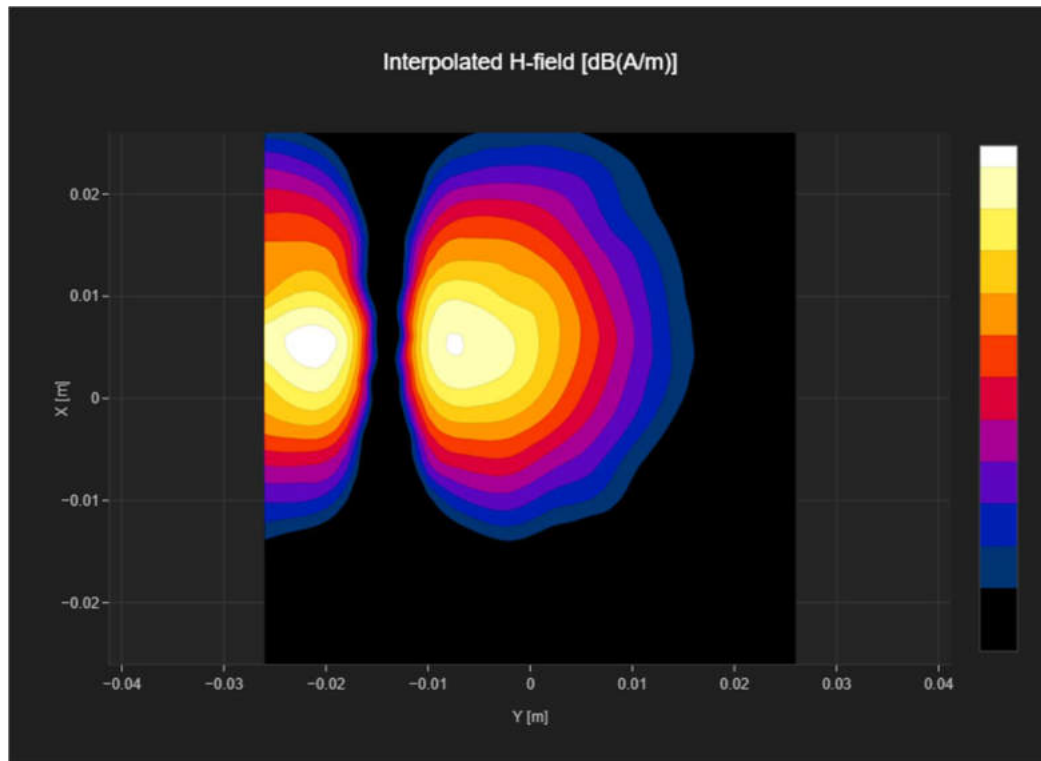

T-Coil Noise Test Report

Measurement performed on January 31, 2024 at 14:34

Device Under Test

Manufacturer	Model	Dimensions [mm]	Speaker Position [mm]
		146.2 x 71.8 x 7.5	144.3

Hardware Setup

Probe Name	Probe Calibration Date	DAE Name	DAE Calibration Date
AM1DV3 - 3082	February 16, 2023	DAE4 Sn1291	March 17, 2023

Communication Systems

Band Name	Communication Systems Name	Channel	Frequency [MHz]
WLAN 5GHz	IEEE 802.11a/h WiFi 5 GHz (OFDM, 6 Mbps)	36	5180.0

Grid Settings

Extent X [mm]	Extent Y [mm]	Step X [mm]	Step Y [mm]	Distance [mm]
52.0	52.0	4.0	4.0	10.0

Results

Secondary Group Point Count	Secondary Group Max Longitudinal	Secondary Group Max Transverse	Hmax [dB(A/m)]
676	26	26	-43.1

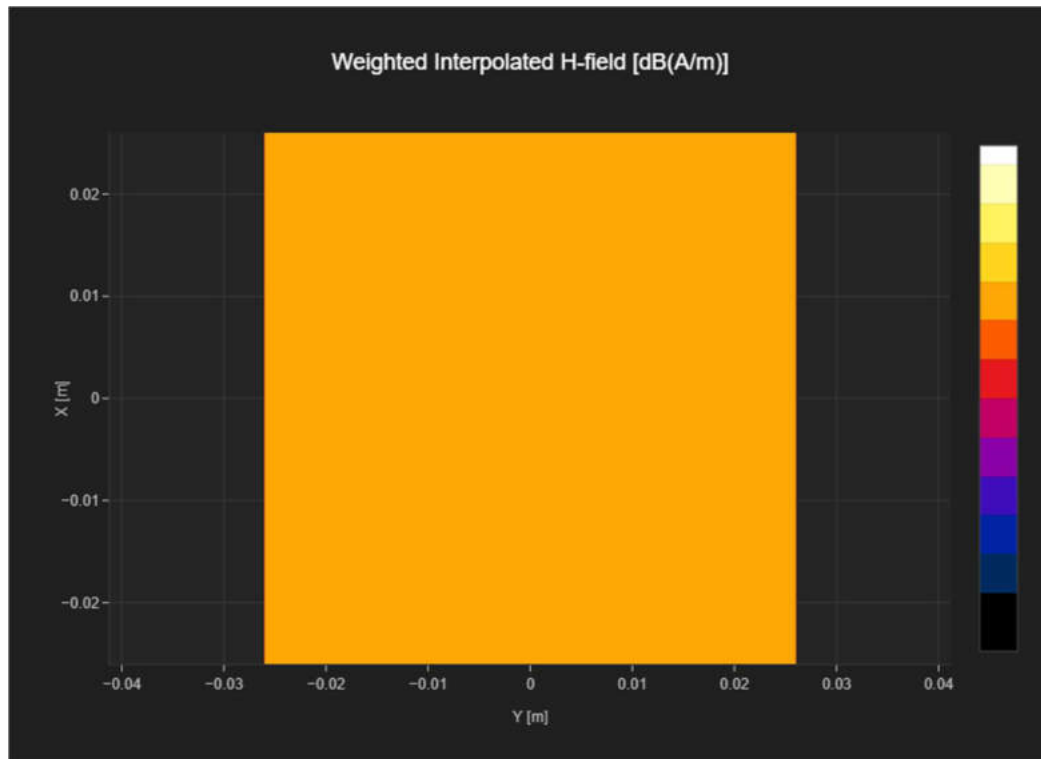

T-Coil Signal Test Report

Measurement performed on January 31, 2024 at 14:54

Device Under Test

Manufacturer	Model	Dimensions [mm]	Speaker Position [mm]
		146.2 x 71.8 x 7.5	144.3

Hardware Setup

Probe Name	Probe Calibration Date	DAE Name	DAE Calibration Date
AM1DV3 - 3082	February 16, 2023	DAE4 Sn1291	March 17, 2023

Communication Systems

Band Name	Communication Systems Name	Channel	Frequency [MHz]
WLAN 5GHz	IEEE 802.11a/h WiFi 5 GHz (OFDM, 6 Mbps)	36	5180.0

Grid Settings

Extent X [mm]	Extent Y [mm]	Step X [mm]	Step Y [mm]	Distance [mm]
52.0	52.0	4.0	4.0	10.0

Results

Audio File	Measurement Duration [s]	Margin Upper Bound [dB]	Margin Lower Bound [dB]
48k_voice_300-3000_2s.wav	2.0	1.17	1.87

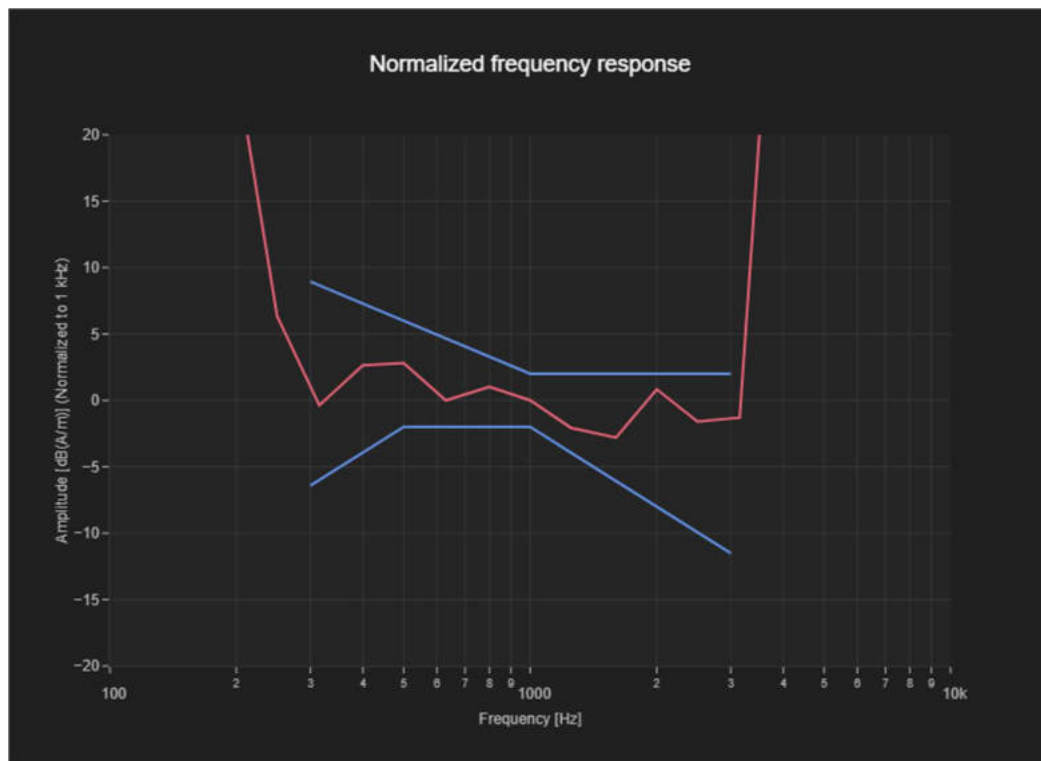

T-Coil Coupling Mode Test Report

Results

Primary Group Contiguous Point Count	Secondary Group Point Count	Secondary Group Max Longitudinal	Secondary Group Max Transverse
144	676	26	26



ANNEX C: Probe Calibration Certificate

**Calibration Laboratory of
Schmid & Partner
Engineering AG**
Zeughausstrasse 43, 8004 Zurich, Switzerland



S Schweizerischer Kalibrierdienst
C Service suisse d'étalonnage
S Servizio svizzero di taratura
S Swiss Calibration Service

Accredited by the Swiss Accreditation Service (SAS)
The Swiss Accreditation Service is one of the signatories to the EA
Multilateral Agreement for the recognition of calibration certificates

Accreditation No.: **SCS 0108**

Client **TA-SH**

Certificate No: **AM1DV3-3082_Feb23**

CALIBRATION CERTIFICATE			
Object	AM1DV3 - SN: 3082		
Calibration procedure(s)	QA CAL-24.v4 Calibration procedure for AM1D magnetic field probes and TMFS in the audio range		
Calibration date:	February 16, 2023		
<p>This calibration certificate documents the traceability to national standards, which realize the physical units of measurements (SI). The measurements and the uncertainties with confidence probability are given on the following pages and are part of the certificate.</p> <p>All calibrations have been conducted in the closed laboratory facility: environment temperature (22 ± 3)°C and humidity < 70%.</p> <p>Calibration Equipment used (M&TE critical for calibration)</p>			
Primary Standards	ID #	Cal Date (Certificate No.)	Scheduled Calibration
Keithley Multimeter Type 2001	SN: 0810278	29-Aug-22 (No. 34389)	Aug-23
Reference Probe AM1DV2	SN: 1008	20-Dec-22 (No. AM1DV2-1008_Dec22)	Dec-23
DAE4	SN: 781	03-Jan-23 (No. DAE4-781_Jan23)	Jan-24
Secondary Standards	ID #	Check Date (in house)	Scheduled Check
AMCC	SN: 1050	01-Oct-13 (in house check Oct-20)	Oct-23
AMMI Audio Measuring Instrument	SN: 1062	26-Sep-12 (in house check Oct-20)	Oct-23
Calibrated by:	Name Aidonia Georgiadou	Function Laboratory Technician	Signature
Approved by:	Name Niels Kuster	Function Quality Manager	
			Issued: February 22, 2023
This calibration certificate shall not be reproduced except in full without written approval of the laboratory.			

References

- [1] ANSI-C63.19-2007
American National Standard for Methods of Measurement of Compatibility between Wireless Communications Devices and Hearing Aids.
- [2] ANSI-C63.19-2019 (ANSI-C63.19-2011)
American National Standard, Methods of Measurement of Compatibility between Wireless Communications Devices and Hearing Aids.
- [3] DASY System Handbook

Description of the AM1D probe

The AM1D Audio Magnetic Field Probe is a fully shielded magnetic field probe for the frequency range from 100 Hz to 20 kHz. The pickup coil is compliant with the dimensional requirements of [1+2]. The probe includes a symmetric low noise amplifier for the signal available at the shielded 3 pin connector at the side. Power is supplied via the same connector (phantom power supply) and monitored via the LED near the connector. The 7 pin connector at the end of the probe does not carry any signals, but determines the angle of the sensor when mounted on the DAE. The probe supports mechanical detection of the surface.

The single sensor in the probe is arranged in a tilt angle allowing measurement of 3 orthogonal field components when rotating the probe by 120° around its axis. It is aligned with the perpendicular component of the field, if the probe axis is tilted nominally 35.3° above the measurement plane, using the connector rotation and sensor angle stated below.

The probe is fully RF shielded when operated with the matching signal cable (shielded) and allows measurement of audio magnetic fields in the close vicinity of RF emitting wireless devices according to [1+2] without additional shielding.

Handling of the item

The probe is manufactured from stainless steel. In order to maintain the performance and calibration of the probe, it must not be opened. The probe is designed for operation in air and shall not be exposed to humidity or liquids. For proper operation of the surface detection and emergency stop functions in a DASY system, the probe must be operated with the special probe cup provided (larger diameter).

Methods Applied and Interpretation of Parameters

- *Coordinate System:* The AM1D probe is mounted in the DASY system for operation with a HAC Test Arch phantom with AMCC Helmholtz calibration coil according to [3], with the tip pointing to "southwest" orientation.
- *Functional Test:* The functional test preceding calibration includes test of Noise level RF immunity (1kHz AM modulated signal). The shield of the probe cable must be well connected. Frequency response verification from 100 Hz to 10 kHz.
- *Connector Rotation:* The connector at the end of the probe does not carry any signals and is used for fixation to the DAE only. The probe is operated in the center of the AMCC Helmholtz coil using a 1 kHz magnetic field signal. Its angle is determined from the two minima at nominally +120° and -120° rotation, so the sensor in the tip of the probe is aligned to the vertical plane in z-direction, corresponding to the field maximum in the AMCC Helmholtz calibration coil.
- *Sensor Angle:* The sensor tilting in the vertical plane from the ideal vertical direction is determined from the two minima at nominally +120° and -120°. DASY system uses this angle to align the sensor for radial measurements to the x and y axis in the horizontal plane.
- *Sensitivity:* With the probe sensor aligned to the z-field in the AMCC, the output of the probe is compared to the magnetic field in the AMCC at 1 kHz. The field in the AMCC Helmholtz coil is given by the geometry and the current through the coil, which is monitored on the precision shunt resistor of the coil.

AM1D probe identification and configuration data

Item	AM1DV3 Audio Magnetic 1D Field Probe
Type No	SP AM1 001 BA
Serial No	3082

Overall length	296 mm
Tip diameter	6.0 mm (at the tip)
Sensor offset	3.0 mm (centre of sensor from tip)
Internal Amplifier	20 dB

Manufacturer / Origin	Schmid & Partner Engineering AG, Zurich, Switzerland
-----------------------	--

Calibration data

Connector rotation angle	(in DASY system)	8.3 °	+/- 3.6 ° (k=2)
Sensor angle	(in DASY system)	0.47 °	+/- 0.5 ° (k=2)
Sensitivity at 1 kHz	(in DASY system)	0.00737 V/(A/m)	+/- 2.2 % (k=2)

The reported uncertainty of measurement is stated as the standard uncertainty of measurement multiplied by the coverage factor k=2, which for a normal distribution corresponds to a coverage probability of approximately 95%.

ANNEX D: DAE4 Calibration Certificate

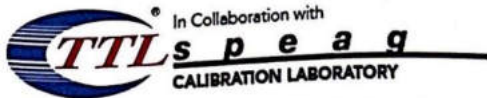

In Collaboration with
 Add: No.52 HuaYuanBei Road, Haidian District, Beijing, 100191, China
 Tel: +86-10-62304633-2117
 E-mail: emf@caict.ac.cn <http://www.caict.ac.cn>



中国认可
 国际互认
 校准
CAICT
 CALIBRATION
 CNAS L0570

Client : **TA(Shanghai)**

Certificate No: **Z23-60184**

CALIBRATION CERTIFICATE			
Object	DAE4 - SN: 1291		
Calibration Procedure(s)	FF-Z11-002-01 Calibration Procedure for the Data Acquisition Electronics (DAEx)		
Calibration date:	March 17, 2023		
<p>This calibration Certificate documents the traceability to national standards, which realize the physical units of measurements(SI). The measurements and the uncertainties with confidence probability are given on the following pages and are part of the certificate.</p> <p>All calibrations have been conducted in the closed laboratory facility: environment temperature(22±3)°C and humidity<70%.</p> <p>Calibration Equipment used (M&TE critical for calibration)</p>			
Primary Standards	ID #	Cal Date(Calibrated by, Certificate No.)	Scheduled Calibration
Process Calibrator 753	1971018	14-Jun-22 (CTTL, No.J22X04180)	Jun-23
Calibrated by:	Name	Function	Signature
	Yu Zongying	SAR Test Engineer	
Reviewed by:	Lin Hao	SAR Test Engineer	
Approved by:	Qi Dianyuan	SAR Project Leader	
			Issued: March 19, 2023
This calibration certificate shall not be reproduced except in full without written approval of the laboratory.			

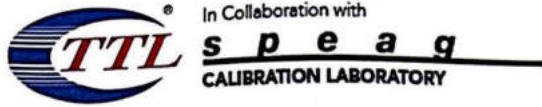

Add: No.52 HuaYuanBei Road, Haidian District, Beijing, 100191, China
 Tel: +86-10-62304633-2117
 E-mail: cmf@caict.ac.cn <http://www.caict.ac.cn>

DC Voltage Measurement

A/D - Converter Resolution nominal
 High Range: 1LSB = 6.1μV, full range = -100...+300 mV
 Low Range: 1LSB = 61nV, full range = -1.....+3mV
 DASY measurement parameters: Auto Zero Time: 3 sec; Measuring time: 3 sec

Calibration Factors	X	Y	Z
High Range	402.588 ± 0.15% (k=2)	403.258 ± 0.15% (k=2)	403.183 ± 0.15% (k=2)
Low Range	3.97410 ± 0.7% (k=2)	3.97852 ± 0.7% (k=2)	3.97390 ± 0.7% (k=2)

Connector Angle

Connector Angle to be used in DASY system	167° ± 1 °
---	------------



Add: No.52 HuaYuanBei Road, Haidian District, Beijing, 100191, China
Tel: +86-10-62304633-2117
E-mail: emf@caict.ac.cn <http://www.caict.ac.cn>

Glossary:

DAE data acquisition electronics
Connector angle information used in DASY system to align probe sensor X to the robot coordinate system.

Methods Applied and Interpretation of Parameters:

- *DC Voltage Measurement:* Calibration Factor assessed for use in DASY system by comparison with a calibrated instrument traceable to national standards. The figure given corresponds to the full scale range of the voltmeter in the respective range.
- *Connector angle:* The angle of the connector is assessed measuring the angle mechanically by a tool inserted. Uncertainty is not required.
- The report provide only calibration results for DAE, it does not contain other performance test results.

ANNEX E: The EUT Appearances

The EUT Appearance are submitted separately.

ANNEX F: Test Setup Photos

The Test Setup Photos are submitted separately.

ANNEX G: Product Change Description

The Product Change Description are submitted separately.

*******END OF REPORT *******