



BUREAU
VERITAS



FCC HAC (RF Emission) Test Report

Report No. : PSU-NQN2311090109SA02

Applicant : HMD Global Oy

Address : Bertel Jungin aukio 9 Espoo 02600 Finland

Manufacturer : HMD Global Oy

Address : Bertel Jungin aukio 9 Espoo 02600 Finland

Product : Smartphone

FCC ID : 2AJOTTA-1590

Brand : HMD

Model No. : N159V

Standards : FCC 47 CFR Part 20.19 / ANSI C63.19-2019
KDB 285076 D01 v06r04 / KDB 285076 D02 v04

Sample Received Date : Jan. 02, 2024

Date of Testing : Jan. 10, 2024 ~ Jan. 11, 2024

FCC Designation No. : CN1325 FCC Site Registration No. : 434559

Issued By : Huarui 7layers High Technology (Suzhou) Co., Ltd.

Address : Tower N, Innovation Center, 88 Zuyi Road, High-tech District, Suzhou City,
Anhui Province China

CERTIFICATION: The above equipment have been tested by **Huarui 7layers High Technology (Suzhou) Co., Ltd.**, and found compliance with the requirement of the above standards. The test record, data evaluation & Equipment Under Test (EUT) configurations represented herein are true and accurate accounts of the measurements of the sample's SAR characteristics under the conditions specified in this report. It should not be reproduced except in full, without the written approval of our laboratory. The client should not use it to claim product certification, approval, or endorsement by A2LA or any government agencies.

Prepared By :

Chao Wu

Chao Wu / Engineer

Approved By :

Sam Peibo

Peibo Sun / Manager

This report is governed by, and incorporates by reference, CPS Conditions of Service as posted at the date of issuance of this report at <http://www.bureauveritas.com/home/about-us/our-business/cps/about-us/terms-conditions> and is intended for your exclusive use. Any copying or replication of this report to or for any other person or entity, or use of our name or trademark, is permitted only with our prior written permission. This report sets forth our findings solely with respect to the test samples identified herein. The results set forth in this report are not indicative or representative of the quality or characteristics of the lot from which a test sample was taken or any similar or identical product unless specifically and expressly noted. Our report includes all of the tests requested by you and the results thereof based upon the information that you provided to us. Measurement uncertainty is only provided upon request for accredited tests. You have 60 days from date of issuance of this report to notify us of any material error or omission caused by our negligence or if you require measurement uncertainty; provided, however, that such notice shall be in writing and shall specifically address the issue you wish to raise. A failure to raise such issue within the prescribed time shall constitute your unqualified acceptance of the completeness of this report, the tests conducted and the correctness of the report contents.



BUREAU
VERITAS



Table of Contents

Release Control Record	3
1. Summary of Maximum RF Value	4
2. Description of Equipment Under Test	5
3. HAC RF Emission Measurement System.....	7
3.1 SPEAG DASY System	7
3.1.1 Robot.....	8
3.1.2 Probes	8
3.1.3 Data Acquisition Electronics (DAE)	9
3.1.4 Phantoms	9
3.1.5 Device Holder.....	9
3.1.6 RF Emission Calibration Dipoles.....	9
3.2 DASY System Verification.....	10
3.3 EUT Measurements Reference and Plane.....	11
3.4 HAC RF Emission Measurement Procedure	12
3.5 Modulation Interference Factor	14
4. HAC Measurement Evaluation.....	16
4.1 WD Emission Requirements	16
4.2 EUT Configuration and Setting.....	17
4.3 System Verification	17
4.4 Maximum Target Conducted Power.....	18
4.5 Measured Conducted Power Results	19
4.6 HAC RFALL Emission Testing Results	20
5. Calibration of Test Equipment.....	21
6. Measurement Uncertainty	22
7. Information of the Testing Laboratories	23

APPENDIX A. PLOTS OF SYSTEM VERIFICATION
APPENDIX B. PLOTS OF HAC RF EMISSION
MEASUREMENT APPENDIX C. CALIBRATION
CERTIFICATE FOR PROBE AND DIPOLE APPENDIX D.
PHOTOGRAPHS OF EUT AND SETUP



BUREAU
VERITAS



Release Control Record

Report No.	Reason for Change	Date Issued
PSU-NQN2311090109SA02	Initial release	Feb. 02, 2024



1. Summary of Maximum RF Value

Mode	Band	Maximum Audio Interference Level RFAIL (dBV/m)	Result
GSM CMRS Voice	GSM850	28.81	PASS
	GSM1900	34.62	PASS
UMTS CMRS Voice	Band II	N/A	PASS
	Band V	N/A	PASS
VoLTE	Band 2	N/A	PASS
	Band 4	N/A	PASS
	Band 5	N/A	PASS
	Band 12	N/A	PASS
	Band 13	N/A	PASS
	Band 66	N/A	PASS
VoWiFi	2.4G	N/A	PASS
	5.2G	N/A	PASS
	5.3G	N/A	PASS
	5.5G	N/A	PASS
	5.8G	N/A	PASS

Note:

1. The HAC RF emission limit is specified in FCC 47 CFR part 20.19 and ANSI C63.19.
2. The device RF emission rating is determined by the minimum rating.



2. Description of Equipment Under Test

EUT Type	Smartphone
FCC ID	2AJOTTA-1590
Brand Name	HMD
Model Name	N159V
Sample 1 IMEI Code	IMEI1: 353407230018145
Sample 2 IMEI Code	IMEI1: 353407230025314
HW Version	V 1.0
SW Version	02US_0_101
Tx Frequency Bands (Unit: MHz)	GSM850 : 824.2 ~ 848.8 GSM1900 : 1850.2 ~ 1909.8 WCDMA Band II : 1852.4 ~ 1907.6 WCDMA Band V : 826.4 ~ 846.6 LTE Band 2 : 1850.7 ~ 1909.3 LTE Band 4 : 1710.7 ~ 1754.3 LTE Band 5 : 824.7 ~ 848.3 LTE Band 12 : 699.7 ~ 715.3 LTE Band 13 : 779.5 ~ 784.5 LTE Band 66 : 1710.7 ~ 1779.3 WLAN : 2412 ~ 2462, 5180 ~ 5240, 5260 ~ 5320, 5500 ~ 5700, 5745 ~ 5825 Bluetooth : 2402 ~ 2480
Uplink Modulations	GSM & GPRS & EDGE : GMSK, 8PSK WCDMA : QPSK LTE : QPSK, 16QAM, 64QAM 802.11b : DSSS 802.11a/g/n/ac : OFDM Bluetooth : GFSK, $\pi/4$ -DQPSK, 8-DPSK
Antenna Type	WWAN ANT1: PIFA Antenna WWAN ANT4 PIFA Antenna WLAN ANT5: PIFA Antenna WLAN ANT6: PIFA Antenna
EUT Stage	Identical Prototype

Note:

1. The above EUT information is declared by manufacturer and for more detailed features description please refers to the manufacturer's specifications or User's Manual.
2. According to the document <Difference of change> provided by the manufacturer, these changes do not affect the RF parameters, so sample 1 is fully tested, and sample 2 verifies the worst case.



**BUREAU
VERITAS**

FCC HAC (RF Emission) Test Report



Certificate #6613.01

Air Interface and Operational Mode:

Air Interface	Bands	Transport Type	ANSI C63.19	Simultaneous But Not Tested	Name of Voice Service	Power Reduction
GSM	850	VO	Yes	WLAN, BT	CMRS Voice ⁽¹⁾	No
	1900			WLAN, BT		No
	EGPRS	VD	Yes	WLAN, BT	Google Meet	No
UMTS	II	VO	No ⁽¹⁾	WLAN, BT	CMRS Voice ⁽¹⁾	No
	V			WLAN, BT		No
	HSPA	VD	No ⁽¹⁾	WLAN, BT	Google Meet	No
LTE (FDD)	2	VD	No ⁽¹⁾	WLAN, BT	VoLTE ⁽¹⁾ / Google Meet	No
	4			WLAN, BT		No
	5			WLAN, BT		No
	12			WLAN, BT		No
	13			WLAN, BT		No
	66			WLAN, BT		No
WLAN	2.4G	VD	No ⁽¹⁾	GSM, WCDMA, LTE	VoWiFi ⁽¹⁾ / Google Meet	No
	5.2G					No
	5.3G					No
	5.5G					No
	5.8G					No
Bluetooth	2.4G	DT	No	GSM, WCDMA, LTE	N/A	No

Transport Type:

VO = Voice Service

DT = Digital Transport Only (No Voice)

VD = IP Voice Service over Digital Transport

Note:

- The air interface max power plus MIF is complies with ANSI C63.19-2019 Table 4.1 RFAIPL.

3. HAC RF Emission Measurement System

3.1 SPEAG DASY System

DASY system consists of high precision robot, probe alignment sensor, phantom, robot controller, controlled measurement server and near-field probe. The robot includes six axes that can move to the precision position of the DASY5 software defined. The DASY software can define the area that is detected by the probe. The robot is connected to controlled box. Controlled measurement server is connected to the controlled robot box. The DAE includes amplifier, signal multiplexing, AD converter, offset measurement and surface detection. It is connected to the Electro-optical coupler (ECO). The ECO performs the conversion form the optical into digital electric signal of the DAE and transfers data to the PC.

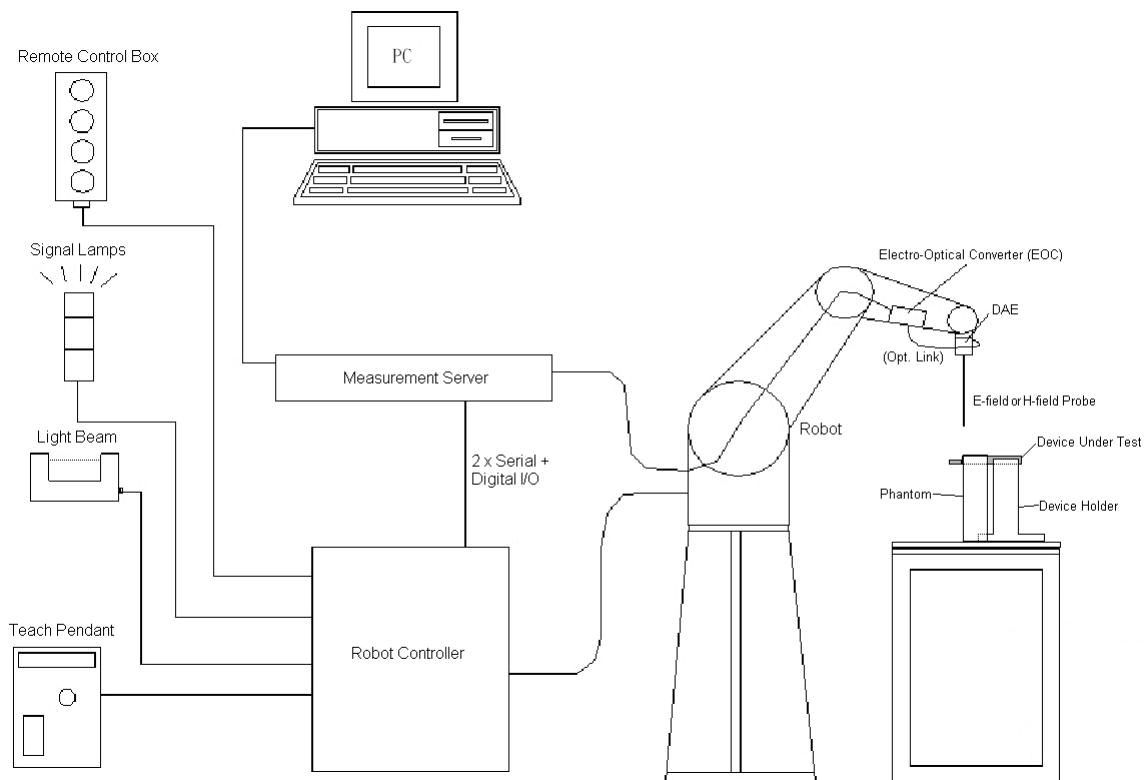

Fig-3.1 DASY System Setup

3.1.1 Robot

The DASY system uses the high precision robots from Stäubli SA (France). For the 6-axis controller system, the robot controller version (DASY6: CS8c) from Stäubli is used. The Stäubli robot series have many features that are important for our application:

- High precision (repeatability ± 0.035 mm)
- High reliability (industrial design)
- Jerk-free straight movements
- Low ELF interference (the closed metallic construction shields against motor control fields)

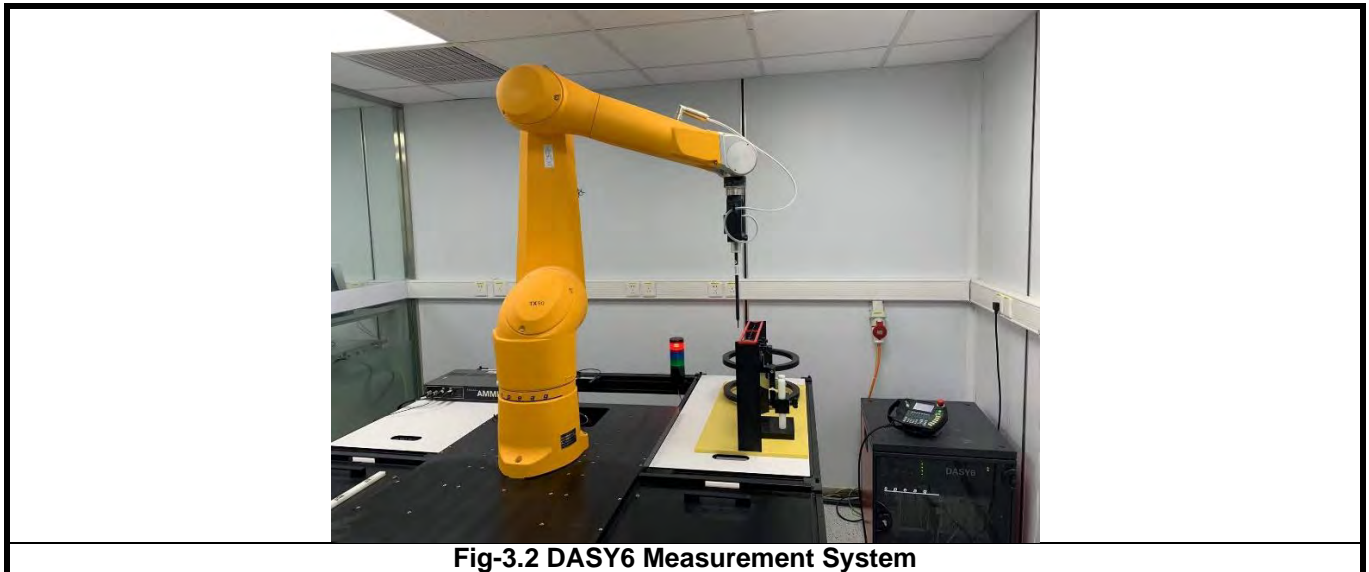

Fig-3.2 DASY6 Measurement System

3.1.2 Probes

Model	ER3DV6	
Construction	One dipole parallel, two dipoles normal to probe axis Built-in shielding against static charges	
Frequency	40 MHz to 3 GHz Linearity: ± 0.2 dB	
Directivity	± 0.2 dB in air (rotation around probe axis) ± 0.4 dB in air (rotation normal to probe axis)	
Dynamic Range	2 V/m to 1000 V/m Linearity: ± 0.2 dB	
Dimensions	Overall length: 337 mm (Tip: 16 mm) Tip diameter: 8 mm (Body: 12 mm) Distance from probe tip to dipole centers: 2.5 mm	

Model	EF3DV3	
Construction	One dipole parallel, two dipoles normal to probe axis Built-in shielding against static charges	
Frequency	40 MHz to 6 GHz Linearity: ± 0.2 dB	
Directivity	± 0.2 dB in air (rotation around probe axis) ± 0.4 dB in air (rotation normal to probe axis)	
Dynamic Range	2 V/m to 1000 V/m Linearity: ± 0.2 dB	
Dimensions	Overall length: 337 mm (Tip: 20 mm) Tip diameter: 3.9 mm (Body: 12 mm) Distance from probe tip to dipole centers: 1.5 mm	

BUREAU VERITAS FCC HAC (RF Emission) Test Report

3.1.3 Data Acquisition Electronics (DAE)

Model	DAE3, DAE4	
Construction	Signal amplifier, multiplexer, A/D converter and control logic. Serial optical link for communication with DASY embedded system (fully remote controlled). Two step probe touch detector for mechanical surface detection and emergency robot stop.	
Measurement Range	-100 to +300 mV (16 bit resolution and two range settings: 4mV, 400mV)	
Input Offset Voltage	< 5µV (with auto zero)	
Input Bias Current	< 50 fA	
Dimensions	60 x 60 x 68 mm	

3.1.4 Phantoms

Model	Test Arch	
Construction	Enables easy and well defined positioning of the phone and validation dipoles as well as simple teaching of the robot.	
Dimensions	Length : 370 mm Width : 370 mm Height : 370 mm	

3.1.5 Device Holder

Model	Mounting Device	
Construction	The Mounting Device enables the rotation of the mounted transmitter device in spherical coordinates. Rotation point is the ear opening point. Transmitter devices can be easily and accurately positioned according to ANSI C63.19.	
Material	POM	

3.1.6 RF Emission Calibration Dipoles

Model	CD-Serial	
Construction	Free space antenna Hearing Aid susceptibility measurements according to ANSI C63.19. Validation of Hearing Aid RF setup for wireless device emission measurements according to ANSI C63.19	
Frequency	CD700V3 : 698 ~ 806 MHz CD835V3 : 800 ~ 960 MHz CD1880V3 : 1710 ~ 2000 MHz CD2450V3 : 2250 ~ 2650 MHz CD2600V3 : 2450 ~ 2750 MHz CD3500V3 : 3300 ~ 3950 MHz CD5500V3 : 5000 ~ 5900 MHz	
Return Loss	CD700V3 : > 15 dB (750 MHz > 20 dB) CD835V3 : > 15 dB (835 MHz > 25 dB) CD1880V3 : > 18 dB (1880 MHz > 20 dB) CD2450V3 : > 18 dB (2450 MHz > 25 dB) CD2600V3 : > 18 dB (2600 MHz > 20 dB) CD3500V3 : > 16 dB (3500 MHz > 20 dB) CD5500V3 : > 18 dB (5500 MHz > 20 dB)	
Power Capability	> 40 W continuous	

3.2 DASY System Verification

The system check verifies that the system operates within its specifications. It is performed before every E-field measurement. The system check uses normal measurements in the center section of the arch phantom with a matched dipole at a specified distance. The system verification setup is shown as below.

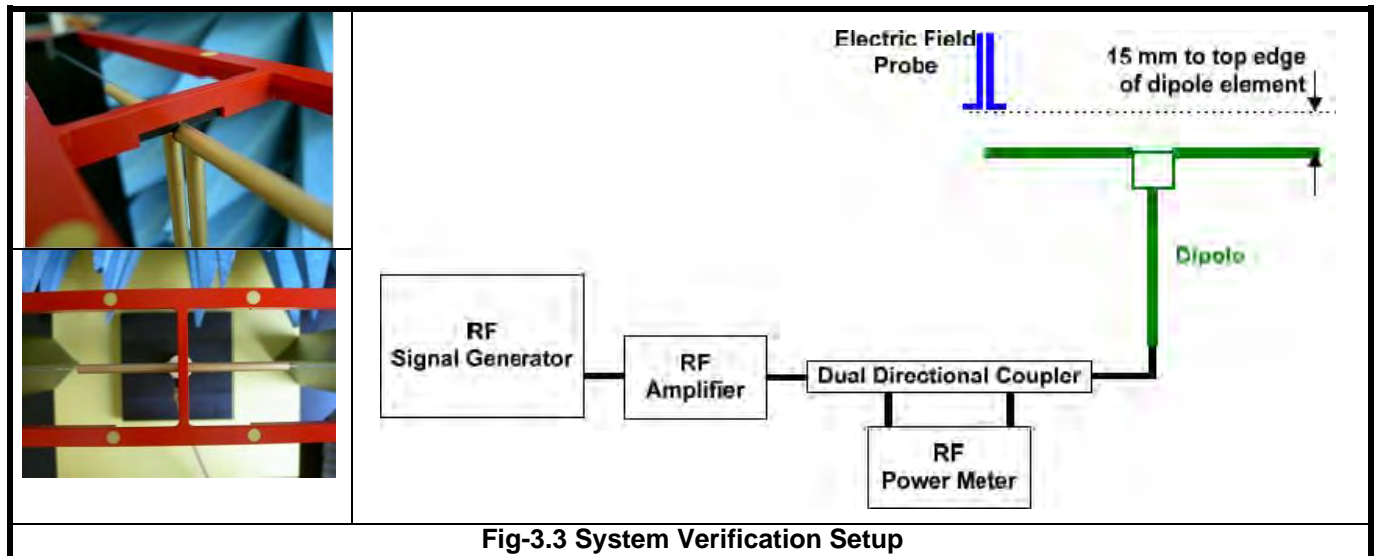

Fig-3.3 System Verification Setup

The validation dipole is placed beneath the center of arch phantom. The power meter measures the forward power at the location of the system check dipole connector. The signal generator is adjusted for the desired forward power, 100 mW (20 dBm) at the dipole connector and the RF power meter is read at that level. After connecting the cable to the dipole, the signal generator is readjusted for the same reading at RF power meter.

After system check testing, the E-field result will be compared with the reference value derived from validation dipole certificate report. The deviation of system check should be within 25 %.

The result of system verification is shown in section 4.3 of this report.

3.3 EUT Measurements Reference and Plane

The EUT is mounted in the device holder. The acoustic output of the EUT will coincide with the center point of the area formed by the dielectric wire and the middle bar of the arch's top frame. Then EUT will be moved vertically upwards until it touches the frame.

Fig-3.4 and Fig-3.5 illustrate the references and reference plane that is used in the RF emissions measurement.

- (a) The measurement area is 50.0 mm by 50.0 mm.
- (b) The grid is centered on the audio frequency output transducer of the EUT.
- (c) The measurement area is in a reference plane, which is defined as the planar area tangent to the highest point in the area of the phone that normally rests against the user's ear. It is parallel to the centerline of the receiver area of the phone and is defined by the points of the receiver-end of the WD handset, which, in normal handset use, rest against the ear.
- (d) The measurement plane is parallel to and 15 mm in front of the reference plane.

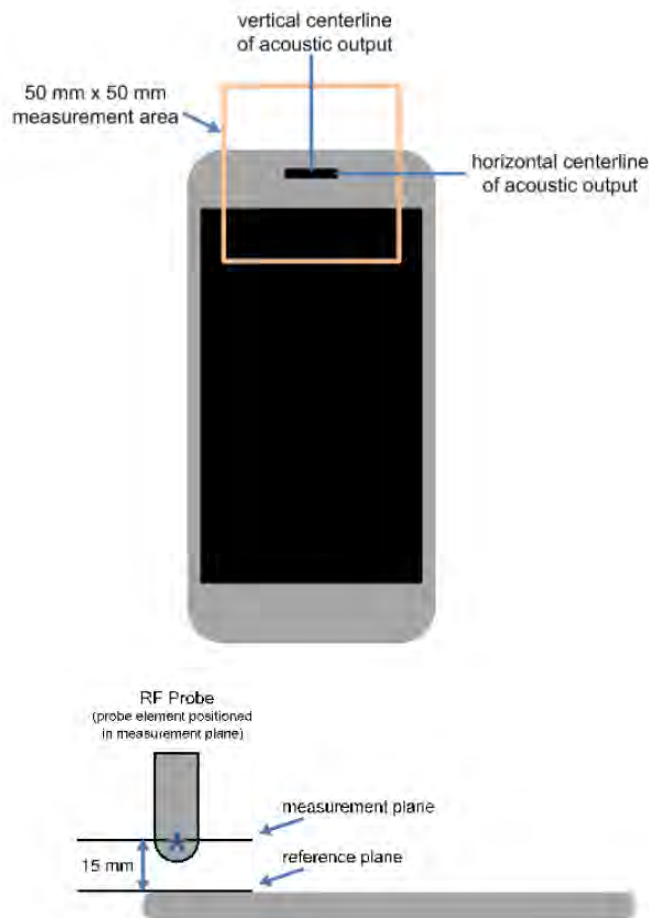
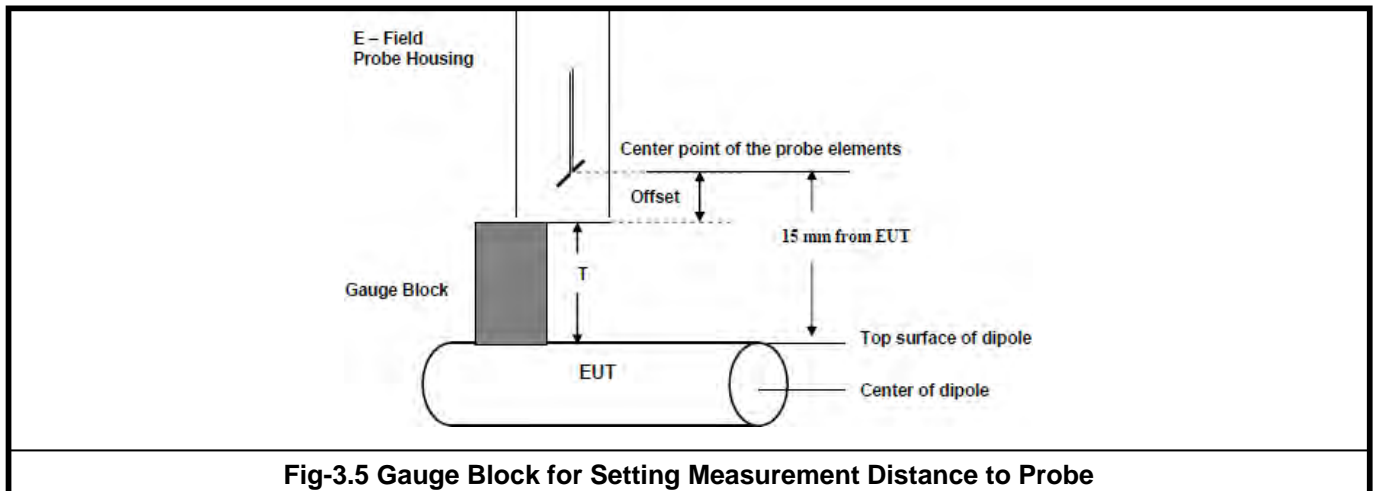

Fig-3.4 The references and reference plane that shall be used in the WD emissions measurement



3.4 HAC RF Emission Measurement Procedure

The RF emissions test procedure for wireless communications device is as below.

1. Confirm proper operation of the field probe, probe measurement system, spectral and temporal weighting filters, and the positioning system.
2. Position the WD in its intended test position.
3. Set the WD to transmit a fixed and repeatable combination of signal power and modulation characteristic that is representative of the worst case (highest interference potential) encountered in normal use. Transiently occurring start-up, changeover, or termination conditions, or other operation likely to occur less than 1% of the time during normal operation, may be excluded from consideration.
4. The center sub-grid shall be centered on the T-Coil mode perpendicular measurement point or the acoustic output, as appropriate. Locate the field probe at the initial test position in the 50 mm by 50 mm grid, which is contained in the measurement plane, illustrated in Fig-3.4. If the field alignment method is used, align the probe for maximum field reception.
5. Record the reading at the output of the measurement system.
6. Scan the entire 50 mm by 50 mm region in equally spaced increments and record the reading at each measurement point. The distance between measurement points shall be sufficient to assure the identification of the maximum reading.
7. Calculate the average of the measurements taken in Step 6.
8. The RF audio interference level in dB(V/m) is obtained by adding the Modulation Interference Factor (in decibels) to the average steady state rms field strength reading over the measurement area, in dB(V/m), from Step 7). Use this result to determine the WD's compliance per ANSI C63.19-2019 Section 4.7

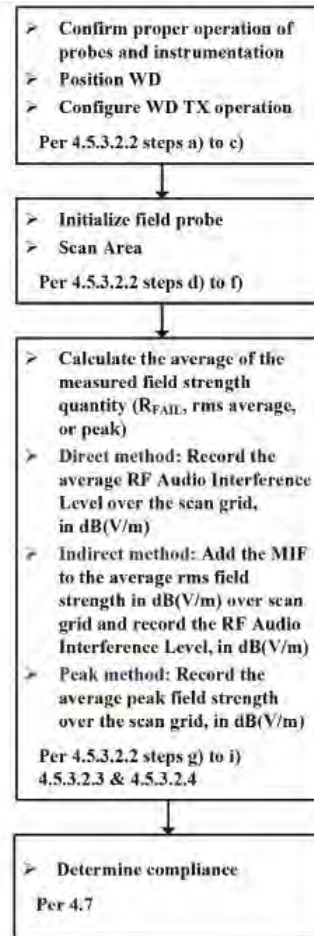

Figure of WD near-field emission scan flowchart according to ANSI C63.19:2019



BUREAU
VERITAS



3.5 Modulation Interference Factor

The HAC Standard ANSI C63.19-2019 defines a new scaling using the Modulation Interference Factor (MIF) which replaces the need for the Articulation Weighting Factor (AWF) during the evaluation and is applicable to any modulation scheme.

The Modulation Interference Factor (MIF, in dB) is added to the measured average E-field (in dBV/m) and converts it to the RF audio interference potential (in dBV/m). This level considers the audible amplitude modulation components in the RF E-field. CW fields without amplitude modulation are assumed to not interfere with the hearing aid electronics. Modulations without time slots and low fluctuations at low frequencies have low MIF values, TDMA modulations with narrow transmission slots and repetition rates of few 100 Hz have high MIF values and give similar classification as ANSI C63.19-2007.

ER3D E-field probe have a bandwidth <10 kHz and can therefore not evaluate the RF envelope in the full audio band. DASY is therefore using the "indirect" measurement method according to ANSI C63.19-2019 which is the primary method. This near field probe read the averaged E-field. Especially for the new high peak-to-average (PAR) signal types, the probes shall be linearized by PMR calibration in order to not overestimate the field reading.

The evaluation method for the MIF is defined in ANSI C63.19-2019. An RMS demodulated RF signal is fed to a spectral filter (similar to an A weighting filter) and forwarded to a temporal filter acting as a quasi-peak detector. The averaged output of these filtering is scaled to a 1 kHz 80% AM signal as reference. It may alternatively be determined through analysis and simulation, because it is constant and characteristic for a communication signal. DASY uses well-defined signals for PMR calibration. The MIF of these signals has been determined numerically. It allows a precise scaling and is therefore automatically applied.

The following table lists the MIF values evaluated by DASY manufacturer (SPEAG), and the test result will be calculated with the MIF parameter automatically. The detailed parameters for E-field probe can be found in the probe calibration report in appendix C.



BUREAU
VERITAS

FCC HAC (RF Emission) Test Report



Certificate #6613.01

UID	Reversion	Communication System Name	MIF (dB)
10021	DAC	GSM-FDD (TDMA, GMSK)	3.63
10025	DAC	EDGE-FDD (TDMA, 8PSK, TN 0)	3.75
10460	AAA	UMTS-FDD (WCDMA, AMR)	-25.43
10225	CAB	UMTS-FDD (HSPA+)	-20.39
10081	CAB	CDMA2000 (1xRTT, RC3)	-19.71
10295	AAB	CDMA2000, RC1, SO3, 1/8th Rate 25 fr.	3.26
10403	AAB	CDMA2000 (1xEV-DO, Rev. 0)	-17.67
10170	CAE	LTE-FDD (SC-FDMA, 1 RB, 20 MHz, 16-QAM)	-9.76
10172	CAG	LTE-TDD (SC-FDMA, 1 RB, 20 MHz, QPSK)	-1.62
10173	CAG	LTE-TDD (SC-FDMA, 1 RB, 20 MHz, 16-QAM)	-1.44
10174	CAG	LTE-TDD (SC-FDMA, 1 RB, 20 MHz, 64-QAM)	-1.54
10769	AAD	5G NR (CP-OFDM, 1 RB, 15 MHz, QPSK, 15 kHz)	-12.08
10973	AAB	5G NR (DFT-S-OFDM, 1 RB, 100 MHz, QPSK, 30 kHz)	-1.64
10061	CAB	IEEE 802.11b WiFi 2.4 GHz (DSSS, 11 Mbps)	-2.02
10077	CAB	IEEE 802.11g WiFi 2.4 GHz (DSSS/OFDM, 54 Mbps)	0.12
10427	AAB	IEEE 802.11n (HT Greenfield, 150 Mbps, 64-QAM)	-13.44
10069	CAC	IEEE 802.11a/h WiFi 5 GHz (OFDM, 54 Mbps)	-3.15
10616	AAB	IEEE 802.11ac WiFi (40MHz, MCS0, 90pc duty cycle)	-5.57
10671	AAC	IEEE 802.11ax (20MHz, MCS0, 90pc duty cycle)	-5.58

The MIF measurement uncertainty listed in following table is estimated by SPEAG.



4. HAC Measurement Evaluation

4.1 WD Emission Requirements

The WD's conducted power must be at or below either the stated RFAIPL (Table 4.1) or the stated peak power level (Table 4.2), or the average near-field emissions over the measurement area must be at or below the stated RFAIL (Table 4.3), or the stated peak field strength (Table 4.4). The WD may demonstrate compliance by meeting any of these four requirements, but it must do so in each of its operating bands at its established worst-case normal speech-mode operating condition.

Table 4.1 - Wireless device RF audio interference power level	
Frequency range (MHz)	RF _{AIPL} [dBm]
< 960	29
960–2000	26
>2000	25

Table 4.2 - Wireless device RF peak power level	
Frequency range (MHz)	RF _{Peak Power} [dBm]
< 960	35
960–2000	32
>2000	31

Table 4.3 - Wireless device RF audio interference level	
Frequency range (MHz)	RF _{ALL} [dB(V/m)]
< 960	39
960–2000	36
>2000	35

Table 4.4 - Wireless device RF peak near-field level	
Frequency range (MHz)	RF _{Peak} [dB(V/m)]
< 960	45
960–2000	42
>2000	41



4.2 EUT Configuration and Setting

For HAC RF emission testing, the EUT was linked and controlled by base station emulator. Communication between the EUT and the emulator was established by air link. The distance between the EUT and the communicating antenna of the emulator is larger than 50 cm and the output power radiated from the emulator antenna is at least 30 dB smaller than the output power of EUT. The EUT was set from the emulator to radiate maximum output power during HAC testing.

4.3 System Verification

The measuring results for system check are shown as below.

Frequency (MHz)	Input Power (dBm)	Target Value (V/m)	E _{max} (V/m)	Deviation (%)	Test Date
835	20	105.7	106	0.28	Jan. 10, 2024
1880	20	86.1	84.1	-2.32	Jan. 10, 2024

Note:

Place a dipole antenna meeting the requirements given in ANSI C63.19: 2019 D.11 in the position normally occupied by the WD. The dipole antenna serves as a known source for an electrical and magnetic output. Position the E-field probe so that:

- a. The probe and its cable are parallel to the coaxial feed of the dipole antenna.
- b. The probe cable and the coaxial feed of the dipole antenna approach the measurement area from opposite directions.
- c. The center point of the probe element(s) is 15 mm from the closest surface of the dipole elements.
- d. Scan the length of the dipole with the E-field probe and record the two maximum values found near the dipole ends. Average the two readings and compare the reading to expected value in the calibration certificate or expected value in this standard.



4.4 Maximum Target Conducted Power

General Note:

1. In this report, max conducted power from each air interface was first used to evaluate whether it complies with ANSI C63.19-2019 Table 4.1 RFAIPL, compliance with table 4.1 means compliance with WD emission requirements. the RFAIPL evaluation refer to section 11.1 for detail.
2. If there some air interface were not meet ANSI C63.19-2019 table 4.1 requirement, these air interfaces were further evaluation ANSI C63.19-2019 Table 4.3 RFAIL requirement. And the RFAIL evaluation result refer to section 13.

<WWAN Max Tune-up >

Air Interface		Max. Tune-up Power
GSM	GSM850	34.50
	EDGE850	28.50
	GSM1900	31.50
	EDGE1900	27.50
WCDMA	Band II	25.50
	Band V	25.50
LTE FDD	Band 2	25.00
	Band 4	25.00
	Band 5	25.50
	Band 12	25.50
	Band 13	25.50
	Band 66	25.00

<WLAN Max Tune-up>

Air Interface		Max. Tune-up Power
WLAN2.4G	802.11b	19.50
	802.11g	18.00
	802.11n HT20	18.00
	802.11n HT40	15.00
WLAN5.2G	802.11a	18.00
	802.11n HT20	18.00
	802.11n HT40	17.00
	802.11ac VHT20	18.00
	802.11ac VHT40	17.00
WLAN5.3G	802.11ac VHT80	14.00
	802.11a	18.00
	802.11n HT20	18.00
	802.11n HT40	17.00
	802.11ac VHT20	18.00
WLAN5.5G	802.11ac VHT40	17.00
	802.11ac VHT80	13.00
	802.11a	18.00
	802.11n HT20	18.00
	802.11n HT40	17.00
WLAN5.8G	802.11ac VHT20	18.00
	802.11ac VHT40	17.00
	802.11ac VHT80	16.00
	802.11a	18.00
	802.11n HT20	18.00



4.5 Measured Conducted Power Results

General Note:

1. Use maximum power plus worst case MIF to determine whether it complies with RF_{AIPL}.
2. If maximum power plus worst case MIF does not comply with RF_{AIPL}, then further evaluation RF_{AIL} include in section 13.
3. EDGE data modes is not necessary due the GSM Voice mode is the worst case.
4. According to ANSI C63.19 2019, if maximum power plus worst case MIF is complies with RF_{AIPL}, means compliance with WD emission requirements.

<WWAN>

Air Interface	Max Average Antenna Input Power (dBm)	Worst Case MIF (dB)	Power + MIF(dB)	C63.19 Lowest RF _{AIPL} (dBm)	C63.19 test required(2019)
GSM850	34.50	3.63	38.13	29.0	Yes
EDGE850	28.50	3.75	32.25	29.0	Yes
GSM1900	31.50	3.63	35.13	26.0	No ⁽³⁾
EDGE1900	27.50	3.75	31.25	26.0	No ⁽³⁾
WCDMA	25.50	-25.43	0.07	26.0	No
WCDMA - HSPA	24.00	-20.39	3.61	26.0	No
LTE - FDD	25.50	-9.76	15.74	25.0	No

<WLAN>

Frequency Bands	Air Interface	Max Average Antenna Input Power (dBm)	Worst Case MIF (dB)	Power + MIF(dB)	C63.19 Lowest RF _{AIPL} (dBm)	C63.19 test required(2019)
WLAN 2.4GHz	802.11b	19.50	-2.02	17.48	25.0	No
	802.11g	18.00	0.12	18.12	25.0	No
	802.11n-HT20	18.00	-13.44	4.56	25.0	No
	802.11n-HT40	15.00	-13.44	1.56	25.0	No
WLAN 5GHz	802.11a	18.00	-3.15	14.85	25.0	No
	802.11n-HT20	18.00	-13.44	4.56	25.0	No
	802.11n-HT40	18.00	-13.44	4.56	25.0	No
	802.11ac-VHT20	18.00	-5.57	12.43	25.0	No
	802.11ac-VHT40	17.00	-5.57	11.43	25.0	No
	802.11ac-VHT80	16.00	-5.57	10.43	25.0	No

4.5.1 Conducted RF Output Power (Unit: dBm)

<GSM>

Band	GSM850			GSM1900		
Channel	128	189	251	512	661	810
Frequency	824.2	836.4	848.8	1850.2	1880	1909.8
GSM (GMSK, 1 Tx Slot)	32.96	32.91	32.99	30.04	29.93	29.92



BUREAU
VERITAS



4.6 HAC RF_{ALL} Emission Testing Results

General Note:

1. The HAC measurement system applies MIF value onto the measured RMS E-field, which is indirect method in ANSI C63.19-2019 version, and reports the RF audio interference level.
2. Phone Condition: Mute on; Backlight off; Max Volume.

Plot No.	Air Interface	Modulation/Mode	Channel	Sample	Average Antenna Input Power (dBm)	MIF	E-Field (V/m)
P01	GSM850	GSM Voice	128	1	32.96	3.63	26.69
P02	GSM850	GSM Voice	189	1	32.91	3.63	27.72
P03	GSM850	GSM Voice	251	1	32.99	3.63	28.81
	GSM850	GSM Voice	251	2	32.99	3.63	26.32
P04	GSM1900	GSM Voice	512	1	30.04	3.63	33.91
P05	GSM1900	GSM Voice	661	1	29.93	3.63	34.62
P06	GSM1900	GSM Voice	810	1	29.92	3.63	34.58
	GSM1900	GSM Voice	661	2	29.93	3.63	32.44

Test Engineer: Chang Gao and Zixiao Xia



BUREAU
VERITAS



5. Calibration of Test Equipment

Equipment	Manufacturer	Model	SN	Cal. Date	Cal. Interval
System Validation Dipole	SPEAG	CD835V3	1213	Nov. 17, 2023	3 Years
System Validation Dipole	SPEAG	CD1880V3	1203	Nov. 17, 2023	3 Years
Dosimetric E-field Probe	SPEAG	EF3DV3	4075	Feb.17, 2023	1 Year
Data Acquisition Electronics	SPEAG	DAE4	1633	Feb. 08, 2023	1 Year
Wideband Radio Communication Tester	Rohde&Schwarz	CMW500	169210	Jun. 27, 2022	2 Year
Power Meter	Rohde&Schwarz	NRX	NRX	Feb. 14, 2022	2 Year
Power Sensor	Rohde&Schwarz	NRP6A	NRP6A	Feb. 14, 2022	2 Year
Power Sensor	Rohde&Schwarz	NRP6A	NRP6A	Feb. 14, 2022	2 Year
ESG Analog Signal Generator	Rohde&Schwarz	SMB100A03	SMB100A03	Feb. 15, 2022	2 Year
Coupler	Woken	0110A056020-10	COM27RW1A3	May. 10, 2023	1 Year
Temp.&Humi.Recorder	ANYMETRE	JR912	SZ01	Jun. 19, 2022	2 Year
Test Arch Phantom	SPEAG	Arch	N/A	N/A	N/A

Note:

- Referring to KDB 865664 D01 v01r04, the dipole calibration interval can be extended to 3 years with justification. The dipole are also not physically damaged, or repaired during the interval. The dipole justification can be found in appendix C.
The return loss is < -20dB, within 20% of prior calibration, the impedance is with 5ohm of prior calibration.



6. Measurement Uncertainty

HAC Uncertainty Budget for RF 2019 version According to ANSI C63.19						
Error Description	Uncertainty Value (±%)	Probability	Divisor	(Ci) E	(Ci) H	Standard Uncertainty (E) (±%)
Measurement System						
Probe Calibration	5.1	N	1	1	1	5.1
Axial Isotropy	4.7	R	1.732	1	1	2.7
Sensor Displacement	16.5	R	1.732	1	0.145	9.5
Boundary Effects	2.4	R	1.732	1	1	1.4
Phantom Boundary Effect	7.2	R	1.732	1	0	4.2
Linearity	4.7	R	1.732	1	1	2.7
Scaling with PMR calibration	10.0	R	1.732	1	1	5.8
System Detection Limit	1.0	R	1.732	1	1	0.6
Readout Electronics	0.3	N	1	1	1	0.3
Response Time	2.6	R	1.732	1	1	1.5
Integration Time	2.6	R	1.732	1	1	1.5
RF Ambient Conditions	3.0	R	1.732	1	1	1.7
RF Reflections	12.0	R	1.732	1	1	6.9
Probe Positioner	1.2	R	1.732	1	0.67	0.7
Probe Positioning	4.7	R	1.732	1	0.67	2.7
Extrap. and Interpolation	1.0	R	1.732	1	1	0.6
Test Sample Related						
Device Positioning Vertical	4.7	R	1.732	1	0.67	2.7
Device Positioning Lateral	1.0	R	1.732	1	1	0.6
Device Holder and Phantom	2.4	R	1.732	1	1	1.4
Power Drift	5.0	R	1.732	1	1	2.9
Phantom and Setup Related						
Phantom Thickness	2.4	R	1.732	1	0.67	1.4
Combined Std. Uncertainty						16.4%
Coverage Factor for 95 %						K=2
Expanded STD Uncertainty						32.7%

Uncertainty budget for HAC RF Emission



BUREAU
VERITAS



7. Information of the Testing Laboratories

We, Huarui 7layers High Technology (Suzhou) Co., Ltd., were founded in 2020 to provide our best service in EMC, Radio, Telecom and Safety consultation.

If you have any comments, please feel free to contact us at the following:

Add: Tower N, Innovation Center, 88 Zuyi Road, High-tech District, Suzhou City, Anhui Province

Tel: [+86 \(0557\) 368 1008](tel:+8605573681008)

The road map of all our labs can be found in our web site also

Web: <http://www.7Layers.com>

---END---



**BUREAU
VERITAS**



Appendix A. Plots of System Verification

HAC_RF_Dipole_835

Measurement performed on January 10, 2024 at 8:28

Device Under Test

Manufacturer	Model	Dimensions [mm]	Speaker Position [mm]
		146.2 x 71.8 x 7.5	144.3

Hardware Setup

Probe Name	Probe Calibration Date	DAE Name	DAE Calibration Date
EF3DV3 - SN4075	February 17, 2023	DAE4 Sn1633	February 08, 2023

Communication Systems

Band Name	Communication Systems Name	Channel	Frequency [MHz]
CD835	CW	50	835.0

Grid Settings

Extent X [mm]	Extent Y [mm]	Step X [mm]	Step Y [mm]	Distance [mm]
20.0	180.0	5.0	5.0	15.0

Results

Dipole Type	Dipole Serial Number	E _{max} [V/m]	Drift [dB]
CD835	1213	106	0.05

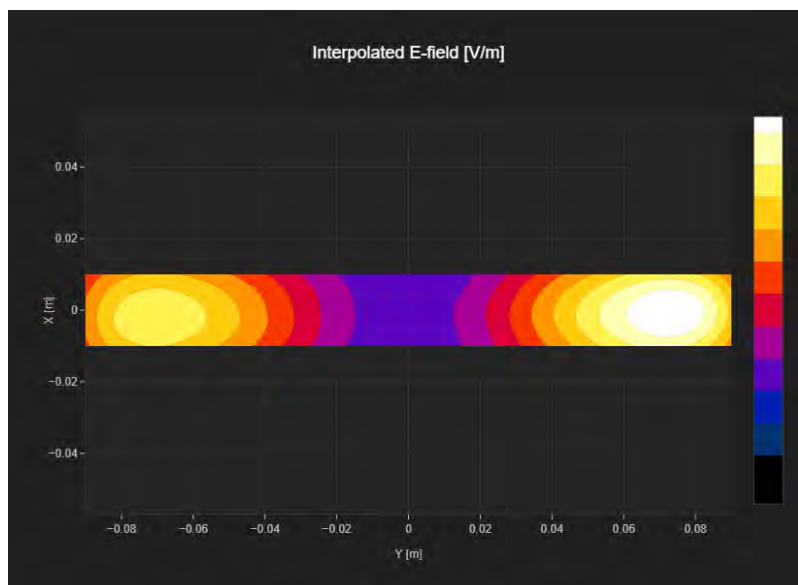

HAC_RF_Dipole_1880

Measurement performed on January 10, 2024 at 8:44

Device Under Test

Manufacturer	Model	Dimensions [mm]	Speaker Position [mm]
		146.2 x 71.8 x 7.5	144.3

Hardware Setup

Probe Name	Probe Calibration Date	DAE Name	DAE Calibration Date
EF3DV3 - SN4075	February 17, 2023	DAE4 Sn1633	February 08, 2023

Communication Systems

Band Name	Communication Systems Name	Channel	Frequency [MHz]
CD1880	CW	50	1880.0

Grid Settings

Extent X [mm]	Extent Y [mm]	Step X [mm]	Step Y [mm]	Distance [mm]
20.0	90.0	5.0	5.0	15.0

Results

Dipole Type	Dipole Serial Number	E _{max} [V/m]	Drift [dB]
CD1880	1203	84.1	-0.0

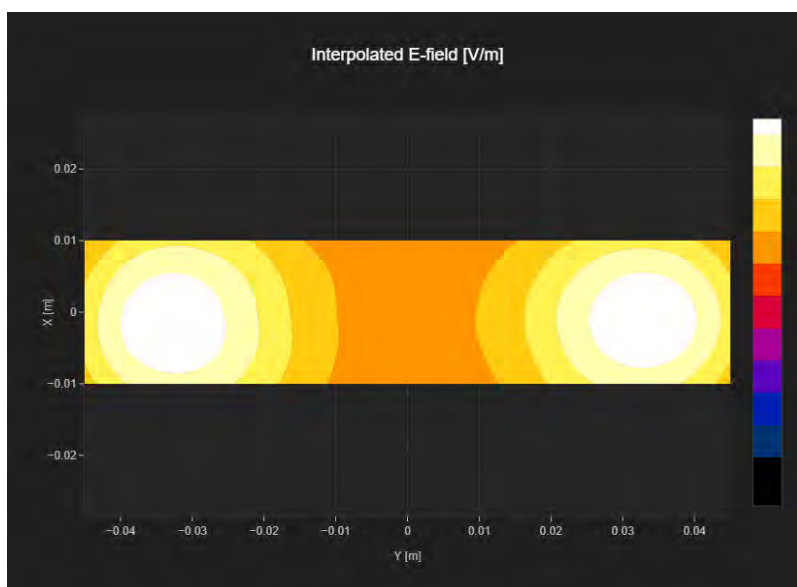



**BUREAU
VERITAS**



Appendix B. Plots of HAC RF Emission Measurement

P01_HAC RF_GSM850_GSM Voice_Ch128

Measurement performed on January 10, 2024 at 10:45

Device Under Test

Manufacturer	Model	Dimensions[mm]	Speaker Position [mm]
		146.2 x 71.8 x 7.5	144.3

Hardware Setup

Probe Name	Probe Calibration Date	DAE Name	DAE Calibration Date
EF3DV3 - SN4075	February 17, 2023	DAE4 Sn1633	February 08, 2023

Communication Systems

Band Name	Communication Systems Name	Channel	Frequency [MHz]
GSM 850	GSM-FDD (TDMA, GMSK)	128	824.2

Grid Settings

Extent X [mm]	Extent Y [mm]	Step X [mm]	Step Y [mm]	Distance [mm]
50.0	50.0	10.0	10.0	15.0

Results

E _{max} [dB(V/m)]	E _{avg50x50 max} [dB(V/m)]	MIF [dB]	RFail [dB(V/m)]
25.26	23.06	3.63	26.69

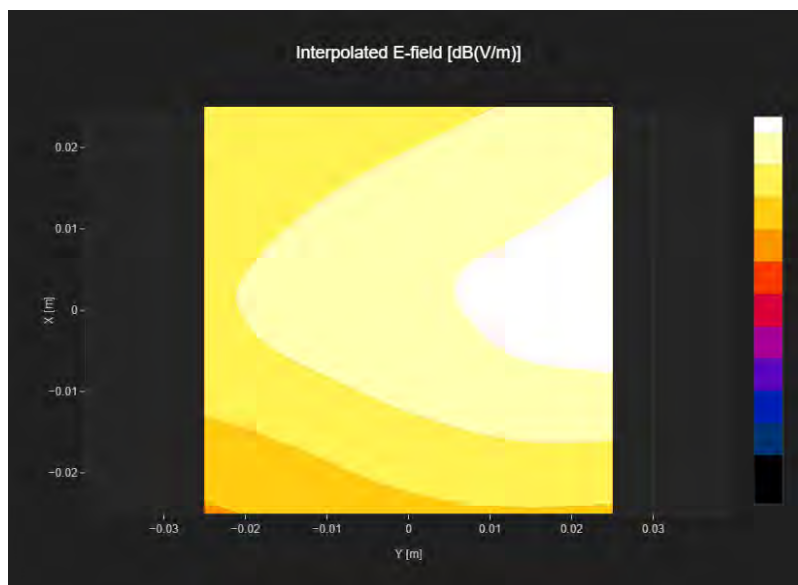

P02_HAC RF_GSM850_GSM Voice_Ch189

Measurement performed on January 10, 2024 at 10:55

Device Under Test

Manufacturer	Model	Dimensions[mm]	Speaker Position [mm]
		146.2 x 71.8 x 7.5	144.3

Hardware Setup

Probe Name	Probe Calibration Date	DAE Name	DAE Calibration Date
EF3DV3 - SN4075	February 17, 2023	DAE4 Sn1633	February 08, 2023

Communication Systems

Band Name	Communication Systems Name	Channel	Frequency [MHz]
GSM 850	GSM-FDD (TDMA, GMSK)	189	836.4

Grid Settings

Extent X [mm]	Extent Y [mm]	Step X [mm]	Step Y [mm]	Distance [mm]
50.0	50.0	10.0	10.0	15.0

Results

E _{max} [dB(V/m)]	E _{avg50x50 max} [dB(V/m)]	MIF [dB]	RFail [dB(V/m)]
26.43	24.09	3.63	27.72

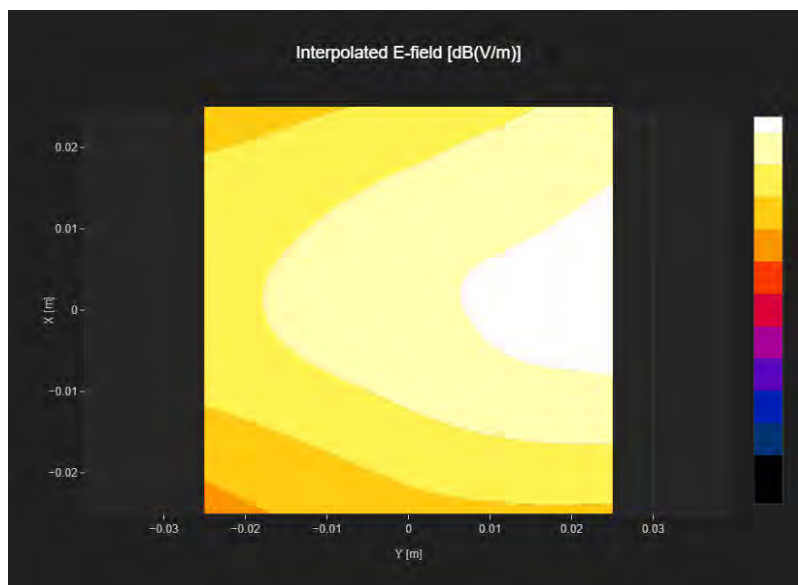

P03_HAC RF_GSM850_GSM Voice_Ch251

Measurement performed on January 10, 2024 at 10:58

Device Under Test

Manufacturer	Model	Dimensions[mm]	Speaker Position [mm]
		146.2 x 71.8 x 7.5	144.3

Hardware Setup

Probe Name	Probe Calibration Date	DAE Name	DAE Calibration Date
EF3DV3 - SN4075	February 17, 2023	DAE4 Sn1633	February 08, 2023

Communication Systems

Band Name	Communication Systems Name	Channel	Frequency [MHz]
GSM 850	GSM-FDD (TDMA, GMSK)	251	848.8

Grid Settings

Extent X [mm]	Extent Y [mm]	Step X [mm]	Step Y [mm]	Distance [mm]
50.0	50.0	10.0	10.0	15.0

Results

E _{max} [dB(V/m)]	E _{avg50x50 max} [dB(V/m)]	MIF [dB]	RFail [dB(V/m)]
27.37	25.18	3.63	28.81

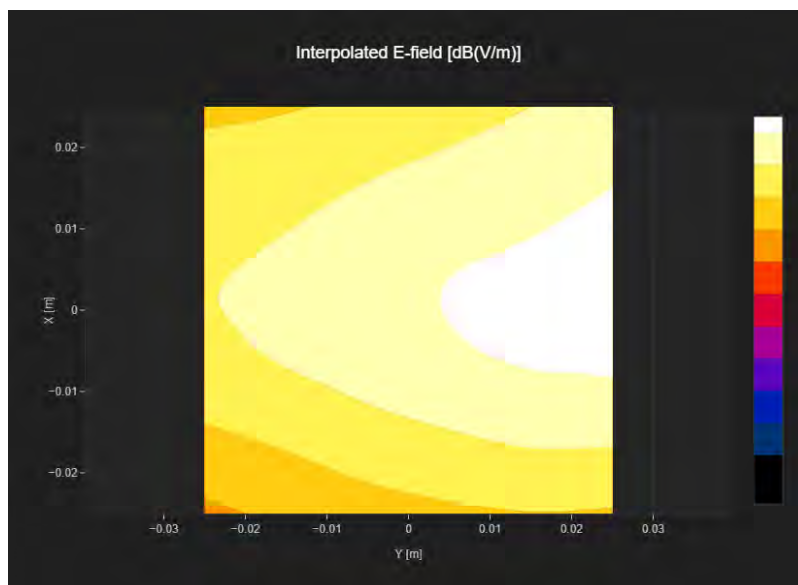

P04_HAC RF_GSM1900_GSM Voice_Ch512

Measurement performed on January 10, 2024 at 11:05

Device Under Test

Manufacturer	Model	Dimensions[mm]	Speaker Position [mm]
		146.2 x 71.8 x 7.5	144.3

Hardware Setup

Probe Name	Probe Calibration Date	DAE Name	DAE Calibration Date
EF3DV3 - SN4075	February 17, 2023	DAE4 Sn1633	February 08, 2023

Communication Systems

Band Name	Communication Systems Name	Channel	Frequency [MHz]
PCS 1900	GSM-FDD (TDMA, GMSK)	512	1850.2

Grid Settings

Extent X [mm]	Extent Y [mm]	Step X [mm]	Step Y [mm]	Distance [mm]
50.0	50.0	10.0	10.0	15.0

Results

E _{max} [dB(V/m)]	E _{avg50x50 max} [dB(V/m)]	MIF [dB]	RFail [dB(V/m)]
33.1	30.28	3.63	33.91

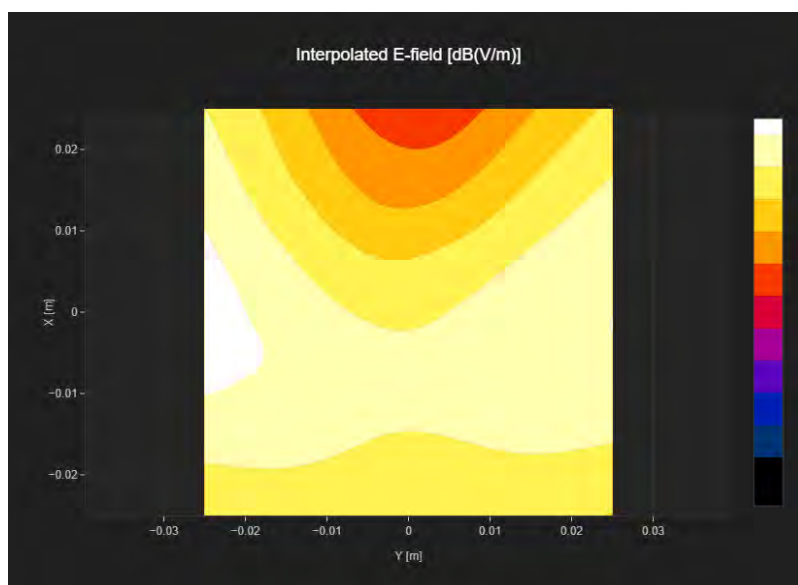

P05_HAC RF_GSM1900_GSM Voice_Ch661

Measurement performed on January 10, 2024 at 11:08

Device Under Test

Manufacturer	Model	Dimensions[mm]	Speaker Position [mm]
		146.2 x 71.8 x 7.5	144.3

Hardware Setup

Probe Name	Probe Calibration Date	DAE Name	DAE Calibration Date
EF3DV3 - SN4075	February 17, 2023	DAE4 Sn1633	February 08, 2023

Communication Systems

Band Name	Communication Systems Name	Channel	Frequency [MHz]
PCS 1900	GSM-FDD (TDMA, GMSK)	661	1880.0

Grid Settings

Extent X [mm]	Extent Y [mm]	Step X [mm]	Step Y [mm]	Distance [mm]
50.0	50.0	10.0	10.0	15.0

Results

E _{max} [dB(V/m)]	E _{avg50x50 max} [dB(V/m)]	MIF [dB]	RFail [dB(V/m)]
34.08	30.99	3.63	34.62

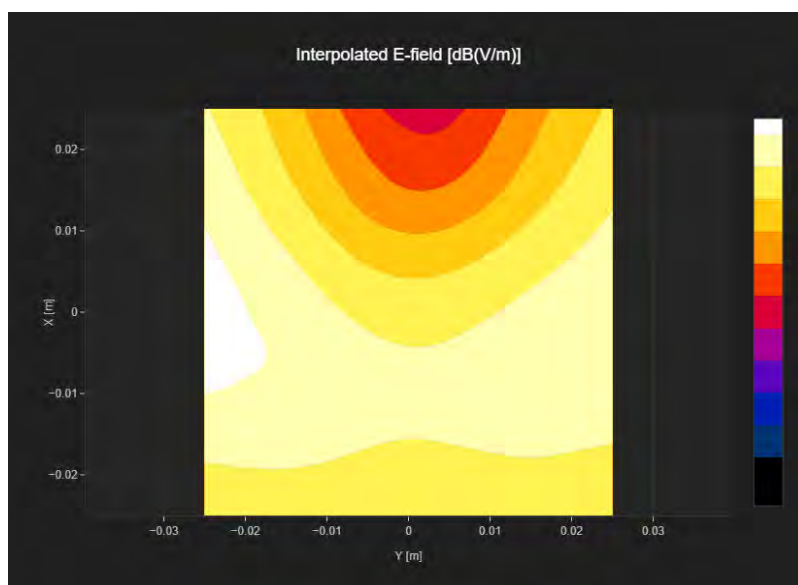

P06_HAC RF_GSM1900_GSM Voice_Ch810

Measurement performed on January 10, 2024 at 11:14

Device Under Test

Manufacturer	Model	Dimensions[mm]	Speaker Position [mm]
		146.2 x 71.8 x 7.5	144.3

Hardware Setup

Probe Name	Probe Calibration Date	DAE Name	DAE Calibration Date
EF3DV3 - SN4075	February 17, 2023	DAE4 Sn1633	February 08, 2023

Communication Systems

Band Name	Communication Systems Name	Channel	Frequency [MHz]
PCS 1900	GSM-FDD (TDMA, GMSK)	810	1909.8

Grid Settings

Extent X [mm]	Extent Y [mm]	Step X [mm]	Step Y [mm]	Distance [mm]
50.0	50.0	10.0	10.0	15.0

Results

E _{max} [dB(V/m)]	E _{avg50x50 max} [dB(V/m)]	MIF [dB]	RFail [dB(V/m)]
33.8	30.95	3.63	34.58

