



Test Report No.: PSU-NQN2311090109RF03



Certificate #6613.01

FCC TEST REPORT (PART 27)

Applicant:	HMD Global Oy
Address:	Bertel Jungin aukio 9 Espoo 02600 Finland

Manufacturer or Supplier:	HMD Global Oy
Address:	Bertel Jungin aukio 9 Espoo 02600 Finland
Product:	Smart Phone
Brand Name:	HMD
Model Name:	N159V
FCC ID:	2AJOTTA-1590
Date of tests:	Jan. 02, 2024 ~ Jan. 30, 2024

The tests have been carried out according to the requirements of the following standard:

- FCC Part 27 ANSI/TIA/EIA-603-D
- FCC Part 2 ANSI/TIA/EIA-603-E ANSI C63.26-2015

CONCLUSION: The submitted sample was found to COMPLY with the test requirement

Prepared by Hanwen Xu
Engineer / Mobile Department

Approved by Peibo Sun
Manager / Mobile Department

Date: Jan. 30, 2024

Date: Jan. 30, 2024

This report is governed by, and incorporates by reference, the Conditions of Testing as posted at the date of issuance of this report at <http://www.bureauveritas.com/home/about-us/our-business/cps/about-us/terms-conditions/> and is intended for your exclusive use. Any copying or replication of this report to or for any other person or entity, or use of our name or trademark, is permitted only with our prior written permission. This report sets forth our findings solely with respect to the test samples identified herein. The results set forth in this report are not indicative or representative of the quality or characteristics of the lot from which a test sample was taken or any similar or identical product unless specifically and expressly noted. Our report includes all of the tests requested by you and the results thereof based upon the information that you provided to us. Measurement uncertainty is only provided upon request for accredited tests. Statements of conformity are based on simple acceptance criteria without taking measurement uncertainty into account, unless otherwise requested in writing. You have 60 days from date of issuance of this report to notify us of any material error or omission caused by our negligence or if you require measurement uncertainty; provided, however, that such notice shall be in writing and shall specifically address the issue you wish to raise. A failure to raise such issue within the prescribed time shall constitute your unqualified acceptance of the completeness of this report, the tests conducted and the correctness of the report contents.



TABLE OF CONTENTS

RELEASE CONTROL RECORD	4
1 SUMMARY OF TEST RESULTS	5
1.1 MEASUREMENT UNCERTAINTY	6
1.2 TEST SITE AND INSTRUMENTS	7
2 GENERAL INFORMATION	9
2.1 GENERAL DESCRIPTION OF EUT	9
2.2 CONFIGURATION OF SYSTEM UNDER TEST	12
2.3 DESCRIPTION OF SUPPORT UNITS	13
2.4 TEST ITEM AND TEST CONFIGURATION	13
2.5 GENERAL DESCRIPTION OF APPLIED STANDARDS	16
3 TEST TYPES AND RESULTS	17
3.1 OUTPUT POWER MEASUREMENT	17
3.1.1 LIMITS OF OUTPUT POWER MEASUREMENT	17
3.1.2 TEST PROCEDURES	17
3.1.3 TEST SETUP	19
3.1.4 TEST RESULTS	20
3.2 FREQUENCY STABILITY MEASUREMENT	31
3.2.1 LIMITS OF FREQUENCY STABILITY MEASUREMENT	31
3.2.2 TEST PROCEDURE	31
3.2.3 TEST SETUP	31
3.2.4 TEST RESULTS	32
3.3 OCCUPIED BANDWIDTH MEASUREMENT	33
3.3.1 LIMITS OF OCCUPIED BANDWIDTH MEASUREMENT	33
3.3.2 TEST SETUP	33
3.3.3 TEST PROCEDURES	33
3.3.4 TEST RESULTS	34
3.4 BAND EDGE MEASUREMENT	35
3.4.1 LIMITS OF BAND EDGE MEASUREMENT	35
3.4.2 TEST SETUP	36
3.4.3 TEST PROCEDURES	37
3.4.4 TEST RESULTS	38
3.5 CONDUCTED SPURIOUS EMISSIONS	39
3.5.1 LIMITS OF CONDUCTED SPURIOUS EMISSIONS MEASUREMENT	39
3.5.2 TEST PROCEDURE	39
3.5.3 TEST SETUP	39
3.5.4 TEST RESULTS	39
3.6 RADIATED EMISSION MEASUREMENT	40
3.6.1 LIMITS OF RADIATED EMISSION MEASUREMENT	40
3.6.2 TEST PROCEDURES	40
3.6.3 DEVIATION FROM TEST STANDARD	40
3.6.4 TEST SETUP	41
3.6.5 TEST RESULTS	43
3.7 PEAK TO AVERAGE RATIO	65
3.7.1 LIMITS OF PEAK TO AVERAGE RATIO MEASUREMENT	65
3.7.2 TEST SETUP	65
3.7.3 TEST PROCEDURES	65
3.7.4 TEST RESULTS	66
4 INFORMATION ON THE TESTING LABORATORIES	67
5 MODIFICATIONS RECORDERS FOR ENGINEERING CHANGES TO THE EUT BY THE LAB... 68	68



BUREAU
VERITAS

Test Report No.: PSU-NQN2311090109RF03

6 APPENDIX 69

- LTE BAND12 69
- PEAK-TO-AVERAGE RATIO(CCDF) 69
- TEST RESULT 69
- TEST GRAPHS 70
- 26DB BANDWIDTH AND OCCUPIED BANDWIDTH 79
- TEST RESULT 79
- BAND EDGE 116
- TEST RESULT 116
- TEST GRAPHS 117
- CONDUCTED SPURIOUS EMISSION 141
- TEST RESULT 141
- TEST GRAPHS 142
- FREQUENCY STABILITY 160
- TEST RESULT 160
- LTE BAND13 163
- PEAK-TO-AVERAGE RATIO(CCDF) 163
- TEST RESULT 163
- TEST GRAPHS 164
- 26DB BANDWIDTH AND OCCUPIED BANDWIDTH 167
- TEST RESULT 167
- BAND EDGE 180
- TEST RESULT 180
- TEST GRAPHS 181
- CONDUCTED SPURIOUS EMISSION 198
- TEST RESULT 198
- TEST GRAPHS 199
- FREQUENCY STABILITY 214
- TEST RESULT 214



Test Report No.: PSU-NQN2311090109RF03

RELEASE CONTROL RECORD

ISSUE NO.	REASON FOR CHANGE	DATE ISSUED
PSU-NQN2311090109RF03	Original release	Jan. 30, 2024

1 SUMMARY OF TEST RESULTS

The EUT has been tested according to the following specifications:

APPLIED STANDARD: FCC PART 27 & PART 2			
STANDARD SECTION	TEST TYPE AND LIMIT	RESULT	TEST LAB*
§2.1046	Conducted Output Power	Compliance	A
§27.50(c)(10)	Effective Radiated Power (Band 12) (Band 13)	Compliance	A
§27.50(d)(4)	Equivalent Isotropically Radiated Power	Compliance	A
§2.1055 §27.54	Frequency Stability	Compliance	A
§2.1049	Occupied Bandwidth	Compliance	A
§2.1051 §27.53(g) §27.53(h)	Conducted Band Edge Measurements (Band 12) (Band 13)	Compliance	A
§2.1051 §27.53(g) §27.53(h)	Conducted Spurious Emissions (Band 12) (Band 13)	Compliance	A
§2.1053 §27.53(g) §27.53(h)	Radiated Spurious Emissions (Band 12) (Band 13)	Compliance	A
N/A	Peak to average ratio	Compliance	A

***Test Lab Information Reference**

Lab A:

Huarui 7Layers High Technology (Suzhou) Co., Ltd.

Lab Address:

Tower N, Innovation Center, 88 Zhuyi Road, High-tech District, Suzhou City, Anhui Province

Accredited Test Lab Cert 6613.01

The FCC Site Registration No. is 434559; The Designation No. is CN1325.

1.1 MEASUREMENT UNCERTAINTY

Where relevant, the following measurement uncertainty levels have been estimated for tests performed on the EUT as specified in CISPR 16-4-2:

MEASUREMENT	UNCERTAINTY
Frequency Stability	±76.97Hz
Radiated emissions (9KHz~30MHz)	±2.68dB
Radiated emissions & Radiated Power (30MHz~1GHz)	±4.98dB
Radiated emissions & Radiated Power (1GHz ~6GHz)	±4.70dB
Radiated emissions (6GHz ~18GHz)	±4.60dB
Radiated emissions (18GHz ~40GHz)	±4.12dB
Conducted emissions	±4.01dB
Occupied Channel Bandwidth	±43.58KHz
Conducted Output power	±2.06dB
Band Edge Measurements	±4.70dB

This uncertainty represents an expanded uncertainty expressed at approximately the 95% confidence level using a coverage factor of k=2.

1.2 TEST SITE AND INSTRUMENTS

Equipment	Manufacturer	Model No.	Serial No.	Last Cal.	Next Cal.
Pre-Amplifier	R&S	SCU18F1	100815	Aug.30,22	Aug.29,24
Pre-Amplifier	R&S	SCU08F1	101028	Sep.16,22	Sep.15,24
Vector Signal Generator	R&S	SMBV100B	102176	Feb.16,22	Feb.15,24
Signal Generator	R&S	SMB100A	182185	Feb.16,22	Feb.15,24
3m Fully-anechoic Chamber	TDK	9m*6m*6m	HRSW-SZ-E MC-01Chamber	Nov.25,22	Nov.24,25
3m Semi-anechoic Chamber	TDK	9m*6m*6m	HRSW-SZ-E MC-02Chamber	Nov.25,22	Nov.24,25
EMI TEST Receiver	R&S	ESR26	101734	Feb.25,22	Feb.24,24
EMI TEST Receiver	R&S	ESW44	101973	Feb.25,22	Feb.24,24
Bilog Antenna	SCHWARZBECK	VULB 9163	1264	Feb.28,22	Feb.27,24
Horn Antenna	ETS-LINDGREN	3117	227836	Aug.22,22	Aug.21,24
Horn Antenna (18GHz-40GHz)	Steatite Q-par Antennas	QMS 00880	23486	Feb.23,22	Feb.22,24
Horn Antenna	Steatite Q-par Antennas	QMS 00208	23485	Aug.22,22	Aug.21,24
Loop Antenna	SCHWARZ	HFH2-Z2/Z2E	100976	Feb.23,22	Feb.22,24
WIDEBANDRADIO COMMUNICATION TESTER	R&S	CMW500	169399	Jun.27,22	Jun.26,24
Test Software	EMC32	EMC32	N/A	N/A	N/A
6DB attenuator	Tonscend Technology Co., Ltd	N/A	23062787	N/A	N/A
Test Software	ELEKTRA	ELEKTRA4.32	N/A	N/A	N/A
Open Switch and Control Unit	R&S	OSP220	101964	Oct.01,22	Sep.30,24
DC Source	HYELEC	HY3010B	551016	Aug.31,22	Aug.30,24
Hygrothermograph	DELI	20210528	SZ014	Sep.06,22	Sep.05,24
PC	LENOVO	E14	HRSW0024	N/A	N/A
TMC-AMI18843A(CABLE)	R&S	HF290-NMNM-7.00M	N/A	N/A	N/A
TMC-AMI18843A(CABLE)	R&S	HF290-NMNM-4.00M	N/A	N/A	N/A
CABLE	R&S	W13.02	N/A	Oct.27,23	Apr.26,24
CABLE	R&S	W12.14	N/A	Oct.27,23	Apr.26,24
CABLE	R&S	J12J103539-00-1	SEP-03-20-069	Oct.27,23	Apr.26,24
CABLE	R&S	J12J103539-00-1	SEP-03-20-070	Oct.27,23	Apr.26,24



Test Report No.: PSU-NQN2311090109RF03

NOTE:

1. The calibration interval of the above test instruments is 12 months or 24 months or 36 months and the calibrations are traceable to CEPREI/CHINA, GREGT/CHINA and NIM/CHINA.
2. The test was performed in 3m Semi-anechoic Chamber and RF Oven Room.
3. The horn antenna is used only for the measurement of emission frequency above 1GHz if tested.
4. The FCC Site Registration No. is 434559; The Designation No. is CN1325.

2 GENERAL INFORMATION

2.1 GENERAL DESCRIPTION OF EUT

PRODUCT*	Smartphone	
BRAND NAME*	HMD	
MODEL NAME*	N159V	
NOMINAL VOLTAGE*	5.0Vdc (adapter) 3.87Vdc (battery)	
MODULATION TECHNOLOGY*	LTE	QPSK, 16QAM, 64QAM
FREQUENCY RANGE	LTE Band 12 Channel Bandwidth: 1.4MHz	699.7MHz ~ 715.3MHz
	LTE Band 12 Channel Bandwidth: 3MHz	700.5MHz ~ 714.5MHz
	LTE Band 12 Channel Bandwidth: 5MHz	701.5MHz ~ 713.5MHz
	LTE Band 12 Channel Bandwidth: 10MHz	704MHz ~ 711MHz
	LTE Band 13 Channel Bandwidth: 5MHz	779.5MHz ~ 784.5MHz
	LTE Band 13 Channel Bandwidth: 10MHz	782MHz
MAX. ERP POWER	LTE Band 12 Channel Bandwidth: 1.4MHz	42.66mW
	LTE Band 12 Channel Bandwidth: 3MHz	43.15mW
	LTE Band 12 Channel Bandwidth: 5MHz	43.35mW
	LTE Band 12 Channel Bandwidth: 10MHz	43.65mW
	LTE Band 13 Channel Bandwidth: 5MHz	52.24mW
	LTE Band 13 Channel Bandwidth: 10MHz	52.6mW
EMISSION DESIGNATOR	LTE Band 12 Channel Bandwidth: 1.4MHz	QPSK: 1M09G7D
		16QAM: 1M09W7D
		64QAM: 1M09W7D
	LTE Band 12 Channel Bandwidth: 3MHz	QPSK: 2M69G7D
		16QAM: 2M69W7D
		64QAM: 2M69W7D



**BUREAU
VERITAS**

Test Report No.: PSU-NQN2311090109RF03

	LTE Band 12 Channel Bandwidth: 5MHz	QPSK: 4M49G7D
		16QAM: 4M49W7D
		64QAM: 4M48W7D
	LTE Band 12 Channel Bandwidth: 10MHz	QPSK: 8M97G7D
		16QAM: 8M95W7D
		64QAM: 8M95W7D
	LTE Band 13 Channel Bandwidth: 5MHz	QPSK: 4M49G7D
		16QAM: 4M49W7D
		64QAM: 4M48W7D
	LTE Band 13 Channel Bandwidth: 10MHz	QPSK: 8M94G7D
		16QAM: 8M93W7D
		64QAM: 8M93W7D
ANTENNA TYPE*	PIFA Antenna with -5.69dBi gain for LTE12 PIFA Antenna with -4.7dBi gain for LTE13	
HW VERSION*	V 1.0	
SW VERSION*	02US_0_101	
I/O PORTS*	Refer to user's manual	
CABLE SUPPLIED*	USB cable1: non-shielded cable, with w/o ferrite core, 1.0 meter USB cable2: non-shielded cable, with w/o ferrite core, 1.0 meter	
EXTREME TEMPERATURE*	-20-60 °C	
EXTREME VOLTAGE*	3.4V - 4.45V	

NOTE:

- *Since the above data and/or information is provided by the client relevant results or conclusions of this report are only made for these data and/or information , Test Lab is not responsible for the authenticity, integrity and results of the data and information and/or the validity of the conclusion.
- For a more detailed features description, please refer to the manufacturer's specifications or the user's manual.
- The EUT incorporates a SISO function. Physically, the EUT provides one completed transmitter and one receiver.

MODULATION MODE	TX FUNCTION
LTE	1TX/1RX

- For the test results, the EUT had been tested with all conditions. But only the worst case was shown in test report.

- For the product of N159V(FCC ID 2AJOTTA-1590), the following components are different between

Huarui 7layers High Technology
(Suzhou) Co., Ltd.

Tower N, Innovation Center, 88 Zhuyi Road,
High-tech District, Suzhou City, Anhui Province

Tel: +86 (0557) 368 1008



**BUREAU
VERITAS**

Test Report No.: PSU-NQN2311090109RF03

the first and second supply, other parameters are the same.

Component		First supply		Second supply	
		Supplier	specificatons	Supplier	specificatons
PCBA	3GB LPDDR	Longsys	3GB	biwin	3GB
	64GB EMMC	Longsys	64GB	biwin	64GB
	Charger IC	SGMICRO	3.78A Single Cell Switching Battery Charger IC	Unisemi	3.78A Single Cell Switching Battery Charger IC
LCM	LCD	TCL	LCD a-Si TFT;720*1612	icetron	LCD a-Si TFT;720*1612
Front camera	Camera	Union Image	5M;FF	Imaging	5M;FF
CAM	Camera	Union Image	13 AF	Sunwin	13 AF
	Camera	SEGA	2M	Imaging	2M
Acoustic	Vibrator	KunWang	0830	HONGZHIFA	0830
	FPC	XINYE	Speaker FPC: 32.1*11.46*0.15	Lat	Speaker FPC: 32.1*11.46*0.15
LED		Runlite	White LED;500mA;1500mA	latticepower	White LED;500mA;1500mA
Battery		gaoyuan	4000mAh;3.87V;4.45V	highpower	4000mAh;3.87V;4.45V
antenna		Haitong	Omni-directional, Linear, antenna shrapnel	Kexinhuacheng	Omni-directional, Linear, antenna shrapnel
MIC		Gettop	L2.75xW1.85xH0.9 mm	goertek	L2.75xW1.85xH0.9 mm
Data cable		Saibao	5V2A	TorchWay	5V2A

List of Accessory:

ACCESSORIES	BRAND	MANUFACTURER	MODEL	SPECIFICATION
Battery 1	Gaoyuan	N/A	CH426385	Power Rating: 15.48Wh
Battery 2	Highpower	N/A	CH426385	Power Rating: 15.48Wh
AC Adapter	BaiJunDa	BaiJunDa	HAD-010U	I/P: 100-240Vac, O/P: 4.8~5.4Vdc, 2.0A
USB Cable 1	Saibao	N/A	SZN-A036A	Signal Line, 1.0meter 5V 2A
USB Cable 2	TorchWay	N/A	JWUB1651-ZN01H	Signal Line, 1.0meter 5V 2A

2.2 CONFIGURATION OF SYSTEM UNDER TEST FOR RADIATION EMISSION TEST

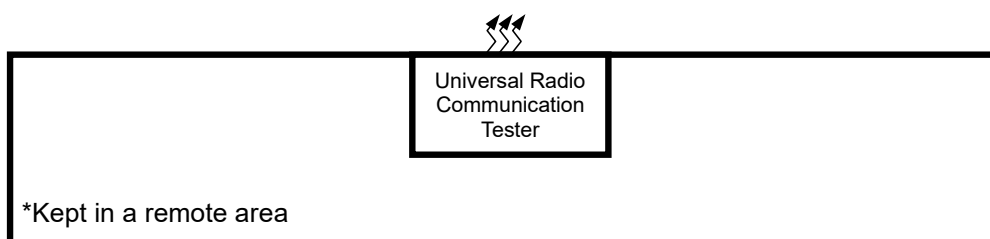
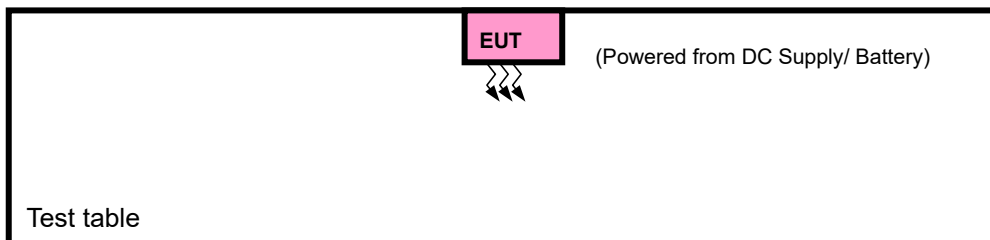
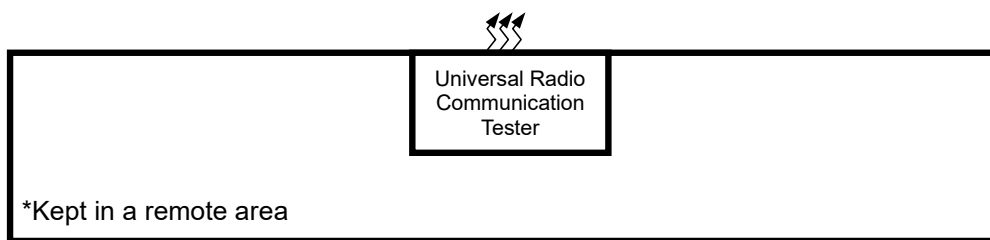
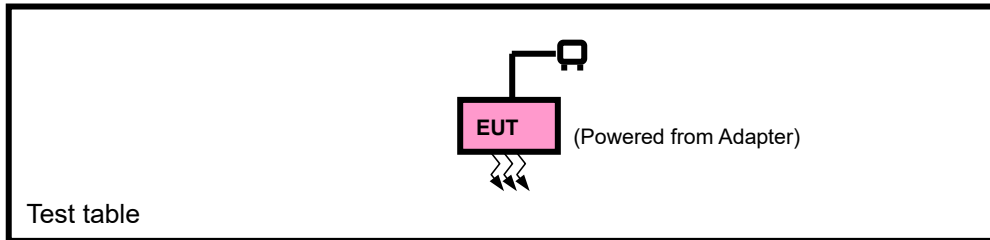



2.3 DESCRIPTION OF SUPPORT UNITS

The EUT has been tested as an independent unit together with other necessary accessories or support units. The following support units or accessories were used to form a representative test configuration during the tests.

NO.	PRODUCT	BRAND	MODEL NO.	SERIAL NO.	FCC ID
1	DC Source	HYELEC	HY3010B	551016	N/A

NO.	SIGNAL CABLE DESCRIPTION OF THE ABOVE SUPPORT UNITS
1	DC Line: Unshielded, Detachable 1.0m

2.4 TEST ITEM AND TEST CONFIGURATION

Pre-Scan has been conducted to determine the worst-case mode from all possible combinations between available modulations, data rates, XYZ axis and antenna ports. The worst case was found when positioned on Y-plane for EIRP and X-axis for radiated emission. Following channel(s) was (were) selected for the final test as listed below:

EUT CONFIGURE MODE	DESCRIPTION
A	EUT + Adapter + USB Cable with LTE link
B	EUT + DC Supply with LTE link

LTE BAND 12 MODE

EUT CONFIGURE MODE	TEST ITEM	AVAILABLE CHANNEL	TESTED CHANNEL	CHANNEL BANDWIDTH	MODULATION	MODE		
A	ERP	23017 to 23173	23017, 23095 , 23173	1.4MHz	QPSK, 16QAM, 64QAM	1 RB / 0 RB Offset		
		23025 to 23165	23025, 23095 ,23165	3MHz	QPSK, 16QAM, 64QAM	1 RB / 0 RB Offset		
		23035 to 23155	23035, 23095 ,23155	5MHz	QPSK, 16QAM, 64QAM	1 RB / 0 RB Offset		
		23060 to 23130	23060, 23095 ,23130	10MHz	QPSK, 16QAM, 64QAM	1 RB / 0 RB Offset		
B	FREQUENCY STABILITY	23017 to 23173	23017, 23095 , 23173	1.4MHz	QPSK, 16QAM, 64QAM	6 RB / 0 RB Offset		
		23025 to 23165	23025, 23095 ,23165	3MHz	QPSK, 16QAM, 64QAM	15 RB / 0 RB Offset		
		23035 to 23155	23035, 23095 ,23155	5MHz	QPSK, 16QAM, 64QAM	25 RB / 0 RB Offset		
		23060 to 23130	23060, 23095 ,23130	10MHz	QPSK, 16QAM, 64QAM	50 RB / 0 RB Offset		
A	OCCUPIED BANDWIDTH	23017 to 23173	23017, 23095 , 23173	1.4MHz	QPSK, 16QAM, 64QAM	6 RB / 0 RB Offset		
		23025 to 23165	23025, 23095 ,23165	3MHz	QPSK, 16QAM, 64QAM	15 RB / 0 RB Offset		
		23035 to 23155	23035, 23095 ,23155	5MHz	QPSK, 16QAM, 64QAM	25 RB / 0 RB Offset		
		23060 to 23130	23060, 23095 ,23130	10MHz	QPSK, 16QAM, 64QAM	50 RB / 0 RB Offset		
A	PEAK TO AVERAGE RATIO	23017 to 23173	23017, 23095 , 23173	1.4MHz	QPSK, 16QAM, 64QAM	1 RB / 0 RB Offset 6 RB / 0 RB Offset		
		23025 to 23165	23025, 23095 ,23165	3MHz	QPSK, 16QAM, 64QAM	1 RB / 0 RB Offset 15 RB / 0 RB Offset		
		23035 to 23155	23035, 23095 ,23155	5MHz	QPSK, 16QAM, 64QAM	1 RB / 0 RB Offset 25 RB / 0 RB Offset		
		23060 to 23130	23060, 23095 ,23130	10MHz	QPSK, 16QAM, 64QAM	1 RB / 0 RB Offset 50 RB / 0 RB Offset		
A	BAND EDGE	23017 to 23173	23017	1.4MHz	QPSK, 16QAM, 64QAM	1 RB / 0 RB Offset 6 RB / 0 RB Offset		
			23173	1.4MHz	QPSK, 16QAM, 64QAM	1 RB / 5 RB Offset 6 RB / 0 RB Offset		
		23025 to 23165	23025	3MHz	QPSK, 16QAM, 64QAM	1 RB / 0 RB Offset 15 RB / 0 RB Offset		
			23165	3MHz	QPSK, 16QAM, 64QAM	1 RB / 14 RB Offset 15 RB / 0 RB Offset		
		23035 to 23155	23035	5MHz	QPSK, 16QAM, 64QAM	1 RB / 0 RB Offset 25 RB / 0 RB Offset		
			23155	5MHz	QPSK, 16QAM, 64QAM	1 RB / 24 RB Offset 25 RB / 0 RB Offset		
		23060 to 23130	23060	10MHz	QPSK, 16QAM, 64QAM	1 RB / 0 RB Offset 50 RB / 0 RB Offset		
			23130	10MHz	QPSK, 16QAM, 64QAM	1 RB / 49 RB Offset 50 RB / 0 RB Offset		
		A	CONDCUDED EMISSION	23017 to 23173	23017, 23095 , 23173	1.4MHz	QPSK, 16QAM, 64QAM	1 RB / 0 RB Offset
				23025 to 23165	23025, 23095 ,23165	3MHz	QPSK, 16QAM, 64QAM	1 RB / 0 RB Offset
				23035 to 23155	23035, 23095 ,23155	5MHz	QPSK, 16QAM, 64QAM	1 RB / 0 RB Offset
				23060 to 23130	23060, 23095 ,23130	10MHz	QPSK, 16QAM, 64QAM	1 RB / 0 RB Offset
A	RADIATED EMISSION	23017 to 23173	23017 ,23095, 23173	1.4MHz	QPSK	1 RB / 0 RB Offset		
		23025 to 23165	23095	3MHz	QPSK	1 RB / 0 RB Offset		
		23035 to 23155	23095	5MHz	QPSK	1 RB / 0 RB Offset		
		23060 to 23130	23095	10MHz	QPSK	1 RB / 0 RB Offset		

Note: This device was tested under all bandwidths, RB configurations and modulations. The worst case was found in QPSK modulation.



**BUREAU
VERITAS**

Test Report No.: PSU-NQN2311090109RF03

LTE BAND 13 MODE

EUT CONFIGURE MODE	TEST ITEM	AVAILABLE CHANNEL	TESTED CHANNEL	CHANNEL BANDWIDTH	MODULATION	MODE		
A	ERP	23205 to 23255	23205, 20175, 23255	5MHz	QPSK,16QAM,64QAM	1 RB / 0 RB Offset		
		23230	23230	10MHz	QPSK,16QAM,64QAM	1 RB / 0 RB Offset		
B	FREQUENCY STABILITY	23230	23230	10MHz	QPSK,16QAM,64QAM	50 RB / 0 RB Offset		
A	OCCUPIED BANDWIDTH	23205 to 23255	23205, 20175, 23255	5MHz	QPSK,16QAM,64QAM	25 RB / 0 RB Offset		
		23230	23230	10MHz	QPSK,16QAM,64QAM	50 RB / 0 RB Offset		
A	PEAK TO AVERAGE RATIO	23230	23230	10MHz	QPSK,16QAM,64QAM	1 RB / 0 RB Offset 50 RB / 0 RB Offset		
A	BAND EDGE	23205 to 23255	23205	5MHz	QPSK,16QAM, 64QAM	1 RB / 0 RB Offset 25 RB / 0 RB Offset		
			23255	5MHz	QPSK,16QAM, 64QAM	1 RB / 24 RB Offset 25 RB / 0 RB Offset		
		23230	23230	10MHz	QPSK,16QAM, 64QAM	1 RB / 0 RB Offset		
						1 RB / 49 RB Offset 50 RB / 0 RB Offset		
		A	CONDCUDETED EMISSION	23205 to 23255	23205, 20175, 23255	5MHz	QPSK,16QAM,64QAM	1 RB / 0 RB Offset
				23230	23230	10MHz	QPSK,16QAM,64QAM	1 RB / 0 RB Offset
A	RADIATED EMISSION	23205 to 23255	23205,23230,23255	5MHz	QPSK	1 RB / 0 RB Offset		
		23230	23230	10MHz	QPSK	1 RB / 0 RB Offset		

Note: This device was tested under all bandwidths, RB configurations and modulations. The worst case was found in QPSK modulation.

TEST CONDITION:

TEST ITEM	ENVIRONMENTAL CONDITIONS	INPUT POWER	TESTED BY
ERP&EIRP	23deg. C, 70%RH	DC 5V By Adapter	Hanwen Xu
FREQUENCY STABILITY	23deg. C, 70%RH	DC 3.85V By DC Supply	Hanwen Xu
OCCUPIED BANDWIDTH	23deg. C, 70%RH	DC5V By Adapter	Hanwen Xu
BAND EDGE	23deg. C, 70%RH	DC 5V By Adapter	Hanwen Xu
CONDCUDETED EMISSION	23deg. C, 70%RH	DC5V By Adapter	Hanwen Xu
RADIATED EMISSION	23deg. C, 70%RH	DC5V By Adapter	Hanwen Xu
PEAK TO AVERAGE RATIO	23deg. C, 70%RH	DC5V By Adapter	Hanwen Xu



Test Report No.: PSU-NQN2311090109RF03

2.5 GENERAL DESCRIPTION OF APPLIED STANDARDS

The EUT is a RF product. According to the specifications of the manufacturer, it must comply with the requirements of the following standards:

FCC 47 CFR Part 2

FCC 47 CFR Part 27

KDB 971168 D01 Power Meas License Digital Systems v03r01

ANSI/TIA/EIA-603-D

ANSI/TIA/EIA-603-E

ANSI C63.26-2015

NOTE: All test items have been performed and recorded as per the above standards.

3 TEST TYPES AND RESULTS

3.1 OUTPUT POWER MEASUREMENT

3.1.1 LIMITS OF OUTPUT POWER MEASUREMENT

The radiated peak output power shall be according to the specific rule Part 27.50(h)(2) that “User stations are limited to 2 watts” and 27.50(i) specific that “Peak transmit power must be measure over any interval of continuous transmission using instrumentation calibration in terms of rms-equivalent voltage.”

Fixed, mobile, and portable (hand-held) stations operating in the 1710-1755 MHz band and mobile and portable stations operating in the 1695-1710 MHz and 1755-1780 MHz bands are limited to 1 watt EIRP

According to the specific rule Part 27.50(b)(10) and 27.50(c)(10) Fixed, mobile, and Portable stations (hand-held devices) transmitting in the 698-746 MHz, 746-757 MHz, 776-788 MHz, and 805-806 MHz bands are limited to 3 watts ERP.

For mobile and portable stations transmitting in the 2305-2315 MHz band or the 2350-2360 MHz band, the average EIRP must not exceed 50 milliwatts within any 1 megahertz of authorized bandwidth, except that for mobile and portable stations compliant with 3GPP LTE standards or another advanced mobile broadband protocol that avoids concentrating energy at the edge of the operating band the average EIRP must not exceed 250 milliwatts within any 5 megahertz of authorized bandwidth but may exceed 50 milliwatts within any 1 megahertz of authorized bandwidth. For mobile and portable stations using time division duplexing (TDD) technology, the duty cycle must not exceed 38 percent in the 2305-2315 MHz and 2350-2360 MHz bands. Mobile and portable stations using FDD technology are restricted to transmitting in the 2305-2315 MHz band. Power averaging shall not include intervals in which the transmitter is off.

3.1.2 TEST PROCEDURES

EIRP MEASUREMENT:

Per KDB 971168 D01 Power Meas License Digital Systems v03r01 or subclause 5.2.5.5 of ANSI C63.26-2015, the relevant equation for determining the ERP or EIRP from the conducted RF output power measured using the guidance provided above is:

$$\text{ERP or EIRP} = P_{\text{Meas}} + G_{\text{T}} - L_{\text{C}}$$

Where:

ERP or EIRP = effective radiated power or equivalent isotropically radiated power, respectively
(expressed in the same units as P_{Meas} , typically dBW or dBm);

P_{Meas} = measured transmitter output power or PSD, in dBm or dBW;



**BUREAU
VERITAS**

Test Report No.: PSU-NQN2311090109RF03

G_T = gain of the transmitting antenna, in dBd (ERP) or dBi (EIRP);

L_c = signal attenuation in the connecting cable between the transmitter and antenna, in dB.

CONDUCTED POWER MEASUREMENT:

- a. The EUT was set up for the maximum power with LTE link data modulation and link up with simulator.
- b. Set the EUT to transmit under low, middle and high channel and record the power level shown on simulator.



Test Report No.: PSU-NQN2311090109RF03

3.1.3 TEST SETUP

CONDUCTED POWER MEASUREMENT:

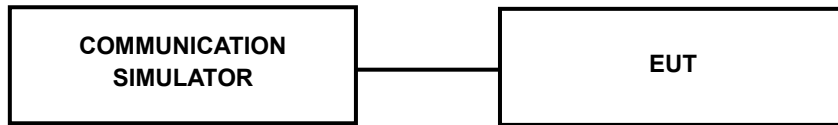

For the actual test configuration, please refer to the attached file (Test Setup Photo).

3.1.4 TEST RESULTS

AVERAGE CONDUCTED OUTPUT POWER (dBm)

LTE Band 12

Band/BW	Modulation	RB Size	RB Offset	Low CH 23017	Mid CH 23095	High CH 23173
				Frequency 699.7 MHz	Frequency 707.5 MHz	Frequency 715.3 MHz
12/ 1.4	QPSK	1	0	24.14	24.02	24.12
		1	2	23.81	23.98	23.80
		1	5	23.86	23.79	24.03
		3	0	23.93	23.96	24.02
		3	1	23.91	23.96	23.81
		3	3	23.79	23.99	24.02
		6	0	22.93	22.90	22.94
	16QAM	1	0	23.27	23.40	23.53
		1	2	23.07	23.06	23.21
		1	5	23.05	23.20	23.36
		3	0	23.06	23.28	23.38
		3	1	23.20	23.19	23.26
		3	3	22.98	23.18	23.08
		6	0	21.81	21.91	21.98
	64QAM	1	0	22.10	22.20	22.20
		1	2	21.96	21.88	22.10
		1	5	21.96	22.07	22.28
		3	0	21.83	21.86	21.85
		3	1	21.89	21.92	22.05
		3	3	21.81	21.95	21.91
		6	0	20.82	20.73	21.05

Band/BW	Modulation	RB Size	RB Offset	Low CH 23025	Mid CH 23095	High CH 23165
				Frequency 700.5 MHz	Frequency 707.5 MHz	Frequency 714.5 MHz
12/ 3	QPSK	1	0	24.19	24.12	24.13
		1	7	23.88	24.07	23.89
		1	14	23.99	23.93	24.15
		8	0	22.98	23.12	23.11
		8	3	23.01	23.06	23.00
		8	7	22.92	23.06	23.10
		15	0	22.95	22.98	22.99
	16QAM	1	0	23.28	23.43	23.55
		1	7	23.20	23.11	23.33
		1	14	23.18	23.22	23.42
		8	0	21.91	22.05	22.14
		8	3	21.99	21.98	22.09
		8	7	21.86	21.93	21.94
		15	0	21.90	21.95	22.04
	64QAM	1	0	22.23	22.33	22.31
		1	7	22.05	22.03	22.25
		1	14	22.10	22.12	22.41
		8	0	20.89	20.99	20.99
		8	3	20.94	20.94	21.08
		8	7	20.92	20.98	21.06
		15	0	20.89	20.87	21.06

Band/BW	Modulation	RB Size	RB Offset	Low CH 23035	Mid CH 23095	High CH 23155
				Frequency 701.5 MHz	Frequency 707.5 MHz	Frequency 713.5 MHz
12/ 5	QPSK	1	0	24.19	24.21	24.20
		1	12	24.01	24.02	23.98
		1	24	23.97	24.01	24.18
		12	0	22.98	23.14	23.12
		12	6	23.05	23.08	22.97
		12	13	23.04	22.93	23.09
		25	0	22.91	22.95	22.96
	16QAM	1	0	23.39	23.32	23.43
		1	12	23.24	23.23	23.32
		1	24	23.23	23.13	23.38
		12	0	21.94	22.10	22.15
		12	6	21.95	21.95	22.03
		12	13	21.85	21.91	21.96
		25	0	21.93	21.89	22.12
	64QAM	1	0	22.14	22.21	22.31
		1	12	21.94	22.12	22.16
		1	24	22.13	22.17	22.29
		12	0	20.92	21.01	21.00
		12	6	21.01	20.99	21.05
		12	13	20.84	20.94	21.01
		25	0	20.86	20.89	21.11

Band/BW	Modulation	RB Size	RB Offset	Low CH 23060	Mid CH 23095	High CH 23130
				Frequency 704 MHz	Frequency 707.5 MHz	Frequency 711 MHz
12/ 10	QPSK	1	0	24.22	24.23	24.24
		1	24	24.02	24.12	24.03
		1	49	24.01	24.08	24.21
		25	0	23.12	23.18	23.23
		25	12	23.09	23.10	23.10
		25	25	23.06	23.07	23.12
		50	0	23.04	23.03	23.10
	16QAM	1	0	23.41	23.45	23.56
		1	24	23.27	23.24	23.41
		1	49	23.26	23.25	23.53
		25	0	22.06	22.16	22.19
		25	12	22.03	22.05	22.17
		25	25	21.98	22.03	22.06
		50	0	21.99	22.02	22.19
	64QAM	1	0	22.29	22.36	22.36
		1	24	22.09	22.18	22.26
		1	49	22.18	22.23	22.43
		25	0	21.03	21.07	21.12
		25	12	21.09	21.03	21.20
		25	25	20.95	21.07	21.16
		50	0	20.99	20.93	21.20



**BUREAU
VERITAS**

Test Report No.: PSU-NQN2311090109RF03

LTE Band 13

Band/BW	Modulation	RB Size	RB Offset	Low CH 23205	Mid CH 23230	High CH 23255
				Frequency 779.5 MHz	Frequency 782.0 MHz	Frequency 784.5 MHz
13/ 5	QPSK	1	0	23.98	24.01	24.03
		1	12	23.96	23.98	23.99
		1	24	23.92	23.99	23.98
		12	0	23.08	22.92	23.16
		12	6	22.97	23.07	23.19
		12	13	22.96	23.10	23.02
		25	0	23.01	23.09	23.04
	16QAM	1	0	23.21	23.15	23.31
		1	12	23.03	23.17	23.24
		1	24	23.01	23.19	23.17
		12	0	21.93	21.97	22.13
		12	6	21.97	22.06	22.03
		12	13	22.01	22.12	22.02
		25	0	22.04	22.05	22.13
	64QAM	1	0	22.06	22.10	22.08
		1	12	22.05	22.04	22.12
		1	24	22.07	22.11	22.08
		12	0	21.08	21.04	21.10
		12	6	21.04	21.09	21.15
		12	13	20.99	21.07	21.03
		25	0	21.05	21.08	21.07



Test Report No.: PSU-NQN2311090109RF03

Band/BW	Modulation	RB Size	RB Offset	/	Mid CH 23230	/
				/	Frequency 782.0 MHz	/
13/ 10	QPSK	1	0	/	24.05	/
		1	24	/	24.02	/
		1	49	/	24.06	/
		25	0	/	23.14	/
		25	12	/	23.11	/
		25	25	/	23.18	/
		50	0	/	23.10	/
	16QAM	1	0	/	23.28	/
		1	24	/	23.14	/
		1	49	/	23.24	/
		25	0	/	22.14	/
		25	12	/	22.05	/
		25	25	/	22.10	/
		50	0	/	22.18	/
	64QAM	1	0	/	22.34	/
		1	24	/	22.15	/
		1	49	/	22.14	/
		25	0	/	21.15	/
		25	12	/	21.07	/
		25	25	/	21.04	/
		50	0	/	21.20	/



BUREAU
VERITAS

Test Report No.: PSU-NQN2311090109RF03

ERP

LTE BAND 12

CHANNEL BANDWIDTH: 1.4MHz QPSK

Channel	Frequency (MHz)	Conducted Power (dBm)	G _T -L _c (dB)	ERP (dBm)	ERP (mW)	Limit (W)
23017	699.7	24.14	-5.69	16.3	42.66	3
23095	707.5	24.02	-5.69	16.18	41.5	3
23173	715.3	24.12	-5.69	16.28	42.46	3

CHANNEL BANDWIDTH: 1.4MHz 16QAM

Channel	Frequency (MHz)	Conducted Power (dBm)	G _T -L _c (dB)	ERP (dBm)	ERP (mW)	Limit (W)
23017	699.7	23.27	-5.69	15.43	34.91	3
23095	707.5	23.4	-5.69	15.56	35.97	3
23173	715.3	23.53	-5.69	15.69	37.07	3

CHANNEL BANDWIDTH: 1.4MHz 64QAM

Channel	Frequency (MHz)	Conducted Power (dBm)	G _T -L _c (dB)	ERP (dBm)	ERP (mW)	Limit (W)
23017	699.7	22.1	-5.69	14.26	26.67	3
23095	707.5	22.2	-5.69	14.36	27.29	3
23173	715.3	22.28	-5.69	14.44	27.8	3

CHANNEL BANDWIDTH: 3MHz QPSK

Channel	Frequency (MHz)	Conducted Power (dBm)	G _T -L _c (dB)	ERP (dBm)	ERP (mW)	Limit (W)
23025	700.5	24.19	-5.69	16.35	43.15	3
23095	707.5	24.12	-5.69	16.28	42.46	3
23165	714.5	24.15	-5.69	16.31	42.76	3

CHANNEL BANDWIDTH: 3MHz 16QAM

Channel	Frequency (MHz)	Conducted Power (dBm)	G _T -L _c (dB)	ERP (dBm)	ERP (mW)	Limit (W)
23025	700.5	23.28	-5.69	15.44	34.99	3
23095	707.5	23.43	-5.69	15.59	36.22	3
23165	714.5	23.55	-5.69	15.71	37.24	3

CHANNEL BANDWIDTH: 3MHz 64QAM

Channel	Frequency (MHz)	Conducted Power (dBm)	G _T -L _c (dB)	ERP (dBm)	ERP (mW)	Limit (W)
23025	700.5	22.23	-5.69	14.39	27.48	3
23095	707.5	22.33	-5.69	14.49	28.12	3
23165	714.5	22.41	-5.69	14.57	28.64	3

CHANNEL BANDWIDTH: 5MHz QPSK

Channel	Frequency (MHz)	Conducted Power (dBm)	G _T -L _c (dB)	ERP (dBm)	ERP (mW)	Limit (W)
23035	701.5	24.19	-5.69	16.35	43.15	3
23095	707.5	24.21	-5.69	16.37	43.35	3
23155	713.5	24.2	-5.69	16.36	43.25	3

CHANNEL BANDWIDTH: 5MHz 16QAM

Channel	Frequency (MHz)	Conducted Power (dBm)	G _T -L _c (dB)	ERP (dBm)	ERP (mW)	Limit (W)
23035	701.5	23.39	-5.69	15.55	35.89	3
23095	707.5	23.32	-5.69	15.48	35.32	3
23155	713.5	23.43	-5.69	15.59	36.22	3



BUREAU
VERITAS

Test Report No.: PSU-NQN2311090109RF03

CHANNEL BANDWIDTH: 5MHz 64QAM

Channel	Frequency (MHz)	Conducted Power (dBm)	G _T -L _c (dB)	ERP (dBm)	ERP (mW)	Limit (W)
23035	701.5	22.14	-5.69	14.3	26.92	3
23095	707.5	22.21	-5.69	14.37	27.35	3
23155	713.5	22.31	-5.69	14.47	27.99	3

CHANNEL BANDWIDTH: 10MHz QPSK

Channel	Frequency (MHz)	Conducted Power (dBm)	G _T -L _c (dB)	ERP (dBm)	ERP (mW)	Limit (W)
23060	704	24.22	-5.69	16.38	43.45	3
23095	707.5	24.23	-5.69	16.39	43.55	3
23130	711	24.24	-5.69	16.4	43.65	3

CHANNEL BANDWIDTH: 10MHz 16QAM

Channel	Frequency (MHz)	Conducted Power (dBm)	G _T -L _c (dB)	ERP (dBm)	ERP (mW)	Limit (W)
23060	704	23.41	-5.69	15.57	36.06	3
23095	707.5	23.45	-5.69	15.61	36.39	3
23130	711	23.56	-5.69	15.72	37.33	3

CHANNEL BANDWIDTH: 10MHz 64QAM

Channel	Frequency (MHz)	Conducted Power (dBm)	G _T -L _c (dB)	ERP (dBm)	ERP (mW)	Limit (W)
23060	704	22.29	-5.69	14.45	27.86	3
23095	707.5	22.36	-5.69	14.52	28.31	3
23130	711	22.43	-5.69	14.59	28.77	3

REMARKS: ERP Output Power (dBm) = EIRP (dBm) -2.15(dB).



**BUREAU
VERITAS**

Test Report No.: PSU-NQN2311090109RF03

LTE BAND 13

CHANNEL BANDWIDTH: 5MHz QPSK

Channel	Frequency (MHz)	Conducted Power (dBm)	G _T -L _c (dB)	ERP (dBm)	ERP (mW)	Limit (W)
23205	779.5	23.98	-4.7	17.13	51.64	3
23230	782	24.01	-4.7	17.16	52	3
23255	784.5	24.03	-4.7	17.18	52.24	3

CHANNEL BANDWIDTH: 5MHz 16QAM

Channel	Frequency (MHz)	Conducted Power (dBm)	G _T -L _c (dB)	ERP (dBm)	ERP (mW)	Limit (W)
23205	779.5	23.21	-4.7	16.36	43.25	3
23230	782	23.19	-4.7	16.34	43.05	3
23255	784.5	23.31	-4.7	16.46	44.26	3

CHANNEL BANDWIDTH: 5MHz 64QAM

Channel	Frequency (MHz)	Conducted Power (dBm)	G _T -L _c (dB)	ERP (dBm)	ERP (mW)	Limit (W)
23205	779.5	22.07	-4.7	15.22	33.27	3
23230	782	22.11	-4.7	15.26	33.57	3
23255	784.5	22.12	-4.7	15.27	33.65	3



BUREAU
VERITAS

Test Report No.: PSU-NQN2311090109RF03

CHANNEL BANDWIDTH: 10MHz QPSK

Channel	Frequency (MHz)	Conducted Power (dBm)	G _T -L _c (dB)	ERP (dBm)	ERP (mW)	Limit (W)
-	-	-	-	-	-	-
23230	782	24.06	-4.7	17.21	52.6	3
-	-	-	-	-	-	-

CHANNEL BANDWIDTH: 10MHz 16QAM

Channel	Frequency (MHz)	Conducted Power (dBm)	G _T -L _c (dB)	ERP (dBm)	ERP (mW)	Limit (W)
-	-	-	-	-	-	-
23230	782	23.28	-4.7	16.43	43.95	3
-	-	-	-	-	-	-

CHANNEL BANDWIDTH: 10MHz 64QAM

Channel	Frequency (MHz)	Conducted Power (dBm)	G _T -L _c (dB)	ERP (dBm)	ERP (mW)	Limit (W)
-	-	-	-	-	-	-
23230	782	22.34	-4.7	15.49	35.4	3
-	-	-	-	-	-	-

REMARKS: ERP Output Power (dBm) = EIRP (dBm) -2.15(dB).

3.2 FREQUENCY STABILITY MEASUREMENT

3.2.1 LIMITS OF FREQUENCY STABILITY MEASUREMENT

The frequency stability shall be sufficient to ensure that the fundamental emissions stay within the authorized bands of operation.

3.2.2 TEST PROCEDURE

- a. Device is placed at the oven room. The oven room could control the temperatures and humidity. Power warm up is at least 15 min and power applied should perform before recording frequency error.
- b. EUT is connected the external power supply to control the DC input power. The test voltage range is from minimum to maximum working voltage. Each step shall be record the frequency error rate.
- c. The temperature range step is 10 degrees in this test items. All temperature levels shall be hold the $\pm 0.5^{\circ}\text{C}$ during the measurement testing. The each temperature step shall be at least 0.5 hours, consider the EUT could be test under the stability condition.

NOTE: The frequency error was recorded frequency error from the communication simulator.

3.2.3 TEST SETUP

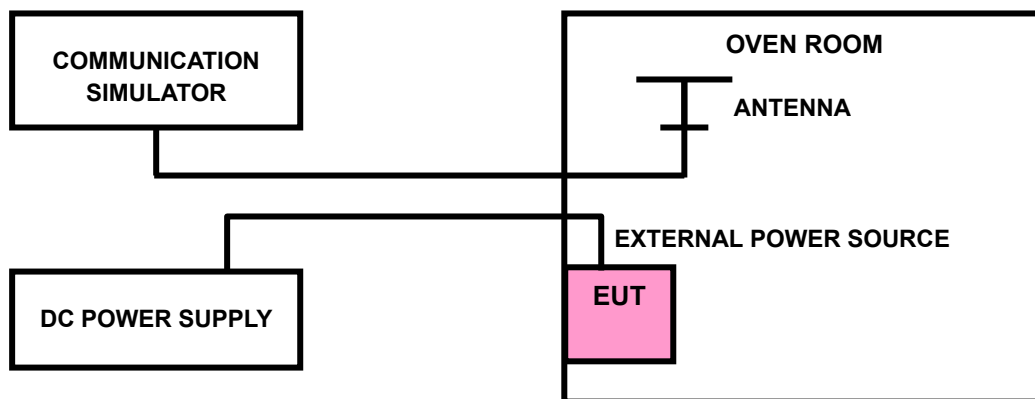



Test Report No.: PSU-NQN2311090109RF03

3.2.4 TEST RESULTS

Please Refer to Appendix Of this test report.

Note: VL = Low voltage(3.4V); VN/NV = Normal voltage(3.85V); VH = High voltage(4.45V);
NT = Normal temperature (25°C)

3.3 OCCUPIED BANDWIDTH MEASUREMENT

3.3.1 LIMITS OF OCCUPIED BANDWIDTH MEASUREMENT

The width of a frequency band such that, below the lower and above the upper frequency limits, the mean powers emitted are each equal to a specified percentage 0.5 % of the total mean power of a given emission.

3.3.2 TEST SETUP

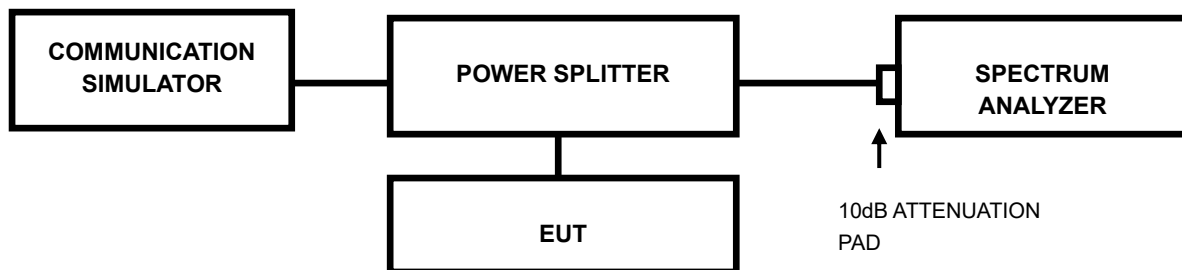

3.3.3 TEST PROCEDURES

- The conducted occupied bandwidth used the power splitter via EUT RF power connector between simulation base station and spectrum analyzer.
- Use OBW measurement function of Spectrum analyzer to measure 99 % occupied bandwidth.



Test Report No.: PSU-NQN2311090109RF03

3.3.4 TEST RESULTS

Please Refer to Appendix Of this test report.



3.4 BAND EDGE MEASUREMENT

3.4.1 LIMITS OF BAND EDGE MEASUREMENT

According to FCC 27.53(c) specified that For operations in the 746-758 MHz band and the 776-788 MHz band , the power of any emission shall be attenuated outside the band below the transmitter power (P) by at least $43 + 10 \log (P)$ dB. However, in the 100 kilohertz bands immediately outside and adjacent to a licensee's frequency block, a resolution bandwidth of at least 30 kHz may be employed. In addition, the power of any unwanted emission in an 6.25kHz bandwidth for all frequencies between 763-775 MHz and 793-806 MHz shall be attenuated below the transmitter power, $P(\text{dBW})$, by at least $65 + 10 \log 10p(P)$, dB, for mobile and portable equipment.

According to FCC 27.53(g) specified that For operations in the 600 MHz band and the 698-746 MHz band, the power of any emission outside a licensee's frequency band(s) of operation shall be attenuated below the transmitter power (P) within the licensed band(s) of operation, measured in watts, by at least $43 + 10 \log (P)$ dB. However, in the 100 kilohertz bands immediately outside and adjacent to a licensee's frequency block, a resolution bandwidth of at least 30 kHz may be employed.

3.4.2 TEST SETUP

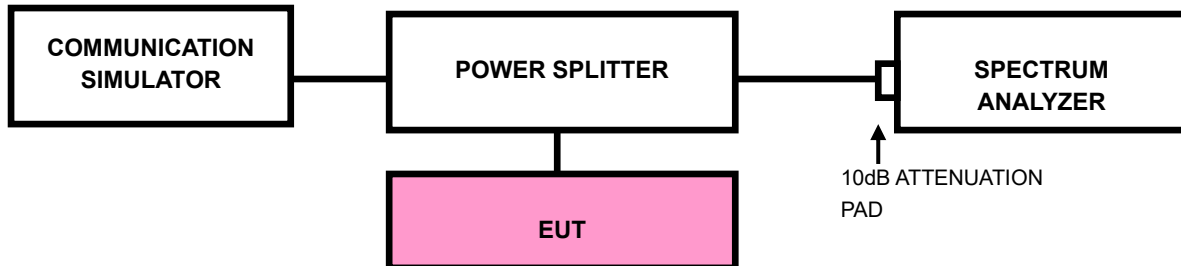



3.4.3 TEST PROCEDURES

- a) All measurements were done at low and high operational frequency range
- b) Connect the transmitter to the spectrum analyzer via coaxial cable while ensuring proper impedance matching.
- c) Tune the analyzer to the nominal center frequency of the emission bandwidth
(EBW)
- d) .Set the resolution bandwidth (RBW) $\geq 1\%$ EBW in the 1MHz band immediately outside and adjacent to the band edge.
- e) Beyond the 1MHz band from the band edge, RBW=1MHz was used.
- f) Set the video bandwidth (VBW) to $\geq 3 \times$ RBW.
- g) Select the average power (RMS) display detector.
- h) Set the number of measurement points to ≥ 1001 .
- i) Use auto-coupled sweep time.
- j) Perform the measurement over an interval of time when the transmission is continuous and at its maximum power level.
- k) The RF fundamental frequency should be excluded against the limit line in the operating frequency band and use RBW is 10KHz or 100KHz.
- l) Record the max trace plot into the test report.



Test Report No.: PSU-NQN2311090109RF03

3.4.4 TEST RESULTS

Please Refer to Appendix Of this test report.

3.5 CONDUCTED SPURIOUS EMISSIONS

3.5.1 LIMITS OF CONDUCTED SPURIOUS EMISSIONS MEASUREMENT

The power of any emission outside of the authorized operating frequency ranges must be attenuated below the transmitting power (P) by a factor of at least $43 + 10 \log(P)$ dB. The emission limit equal to -13dBm .

3.5.2 TEST PROCEDURE

- a. The EUT makes a phone call to the communication simulator. All measurements were done at low, middle and high operational frequency range.
- b. Measuring frequency range is from 9kHz up to a frequency including its 10th harmonic. 10dB attenuation pad is connected with spectrum. RBW=1MHz and VBW=3MHz is used for conducted emission measurement.

3.5.3 TEST SETUP

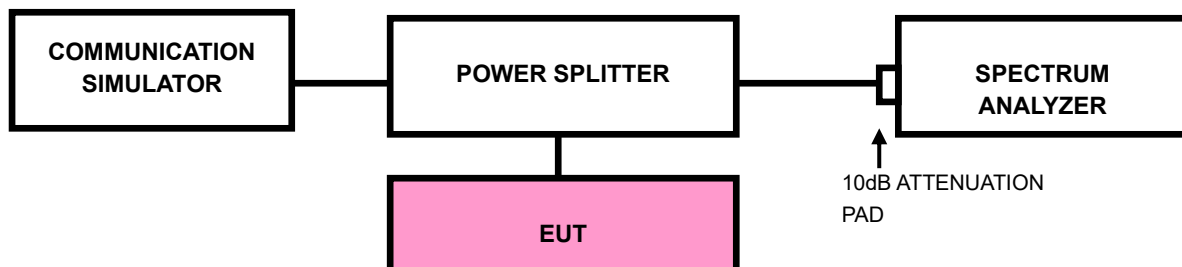

3.5.4 TEST RESULTS

NOTE : The 9K~30MHz amplitude of spurious emissions attenuated more than 20 dB below the permissible value is not required in the report.

Please Refer to Appendix Of this test report.



3.6 RADIATED EMISSION MEASUREMENT

3.6.1 LIMITS OF RADIATED EMISSION MEASUREMENT

The power of any emission outside of the authorized operating frequency ranges must be attenuated below the transmitting power (P) by a factor of at least $43 + 10 \log(P)$ dB. The emission limit equal to -13dBm .

3.6.2 TEST PROCEDURES

- a. Substitution method is used for E.I.R.P measurement. In the semi-anechoic chamber, EUT placed on the 0.8m height of Turn Table, rotated the table around 360 degrees to search the maximum radiation power and receiver antenna shall be rotated vertical and horizontal polarization and moved height from 1m to 4m to find the maximum polar radiated power. The "Read Value" is the spectrum reading the maximum power value.
- b. The substitution horn antenna is substituted for EUT at the same position and signals generator export the CW signal to the substitution antenna via a TX cable. Rotated the Turn Table and moved receiving antenna to find the maximum radiation power. Adjust output power level of S.G to get a Value of spectrum reading equal to "Read Value " of step a. Record the power level of S.G.
- c. $\text{EIRP} = \text{Output power level of S.G} - \text{TX cable loss} + \text{Antenna gain of substitution horn}$.
- d. E.R.P power can be calculated form E.I.R.P power by subtracting the gain of dipole, $\text{E.R.P power} = \text{E.I.P.R power} - 2.15\text{dBi}$.

NOTE: The resolution bandwidth of spectrum analyzer is 1 MHz and the video bandwidth is 3 MHz.

3.6.3 DEVIATION FROM TEST STANDARD

No deviation

3.6.4 TEST SETUP

< Frequency Range below 30MHz >

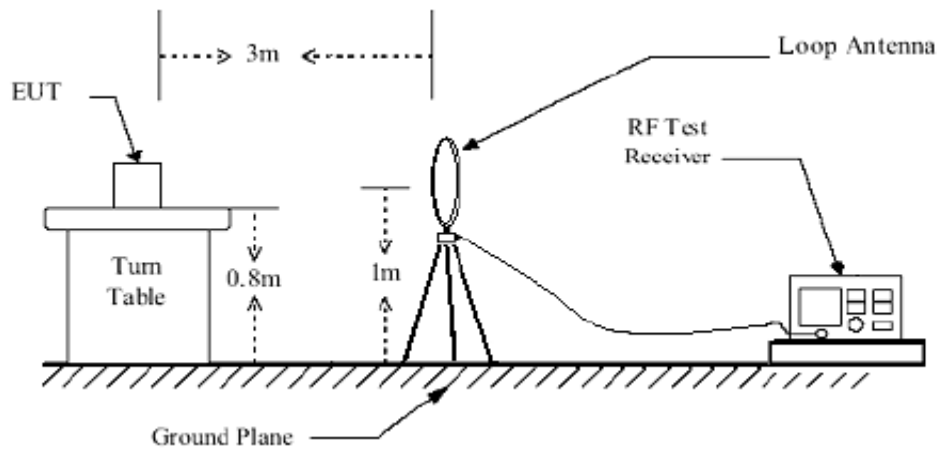

< Frequency Range 30MHz~1GHz >

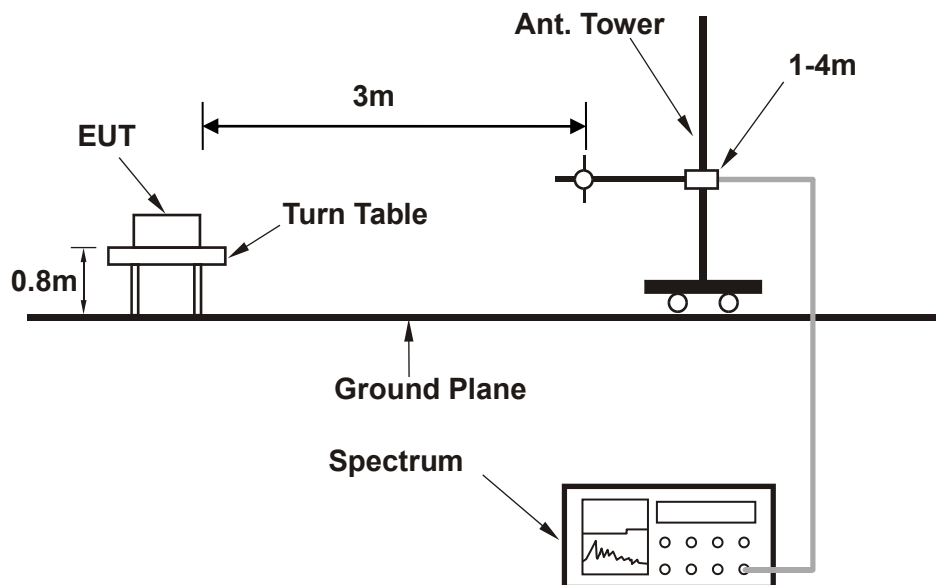



BUREAU
VERITAS

Test Report No.: PSU-NQN2311090109RF03

<Frequency Range above 1GHz>

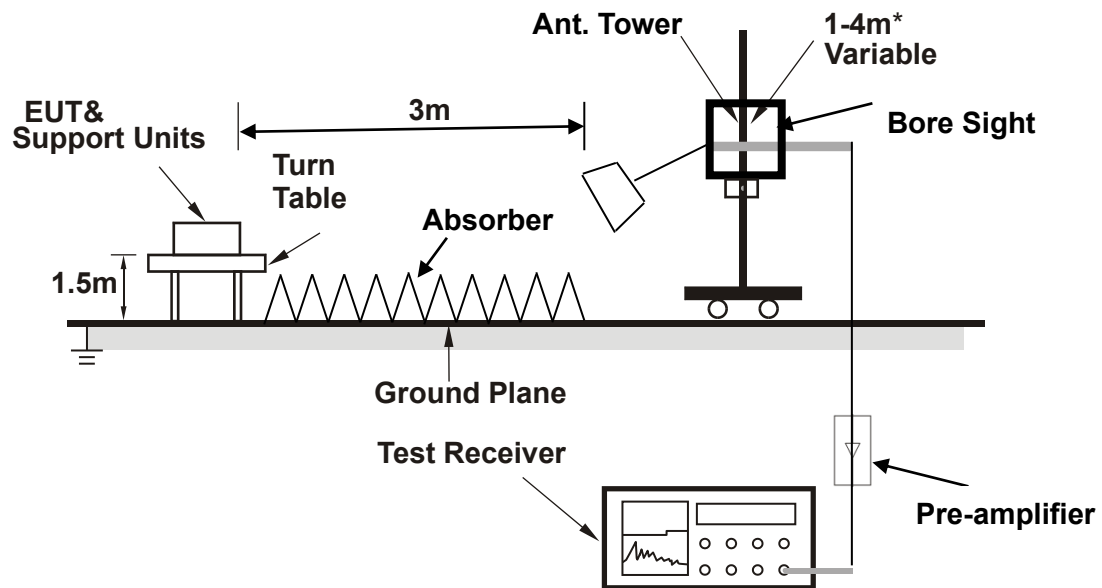

Note: Above 1G is a directional antenna depends on the EUT height and the antenna 3dB beamwidth both, refer to section 7.3 of CISPR 16-2-3.

For the actual test configuration, please refer to the attached file (Test Setup Photo).



Test Report No.: PSU-NQN2311090109RF03

3.6.5 TEST RESULTS

NOTE : The 9K~30MHz amplitude of spurious emissions attenuated more than 20 dB below the permissible value is not required in the report.

BELOW 1GHz WORST-CASE DATA

30 MHz – 1GHz data:

LTE Band 12

CHANNEL BANDWIDTH: 1.4MHz / QPSK

MODE	TX channel 23017	FREQUENCY RANGE	Below 1000MHz
ENVIRONMENTAL CONDITIONS	23deg. C, 70%RH	INPUT POWER	AC 120V/60HZ
TESTED BY	Hanwen Xu		
ANTENNA POLARITY & TEST DISTANCE: HORIZONTAL AT 3 M			

Rg	Frequency [MHz]	PK+ Level [dBm]	PK+ Limit [dBm]	PK+ Margin [dB]	Correction [dB]	Polarization	Azimuth [deg]	Antenna Height [m]
1	31.650	-61.99	-13.00	48.99	5.93	H	24.8	2.00
1	59.150	-60.85	-13.00	47.85	2.62	H	268.6	2.00
1	106.700	-75.49	-13.00	62.49	-5.00	H	122.8	2.00
1	170.100	-71.48	-13.00	58.48	-3.30	H	73.8	2.00
1	233.900	-60.10	-13.00	47.10	8.31	H	359	2.00
1	330.000	-69.73	-13.00	56.73	3.30	H	313.7	1.00

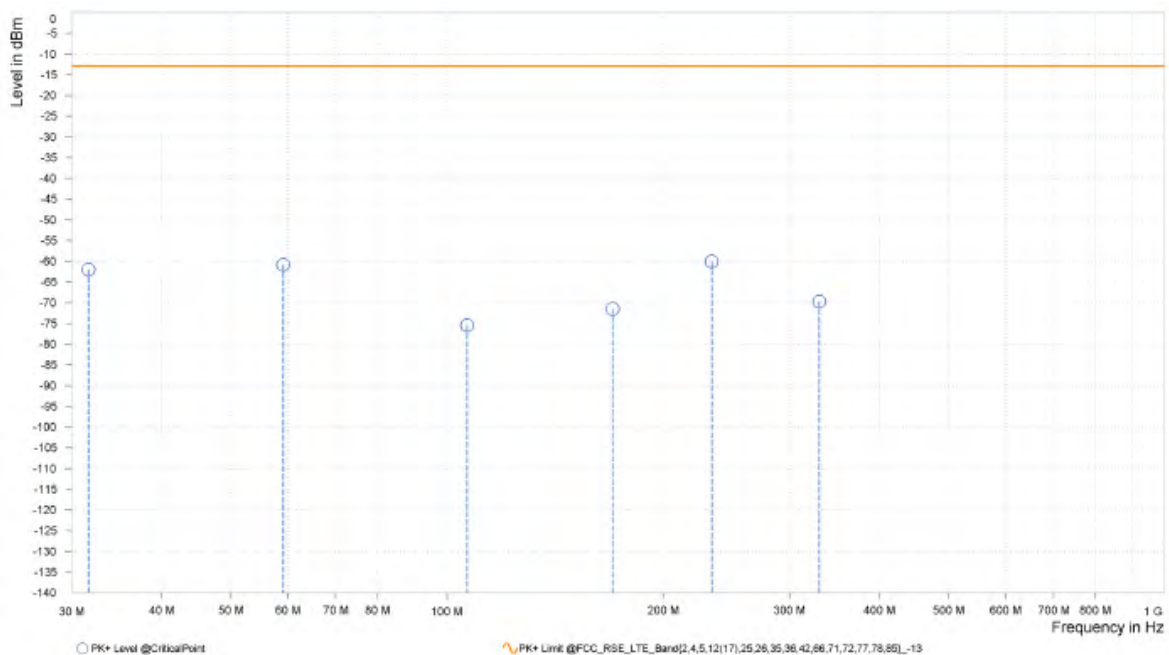



Test Report No.: PSU-NQN2311090109RF03

MODE	TX channel 23017	FREQUENCY RANGE	Below 1000MHz
ENVIRONMENTAL CONDITIONS	23deg. C, 70%RH	INPUT POWER	AC 120V/60HZ
TESTED BY	Hanwen Xu		
ANTENNA POLARITY & TEST DISTANCE: VERTICAL AT 3 M			

Rg	Frequency [MHz]	PK+ Level [dBm]	PK+ Limit [dBm]	PK+ Margin [dB]	Correction [dB]	Polarization	Azimuth [deg]	Antenna Height [m]
1	33.050	-67.76	-13.00	54.76	0.19	V	115.6	2.00
1	58.300	-60.82	-13.00	47.82	3.11	V	91.4	1.00
1	99.800	-59.71	-13.00	46.71	11.38	V	5	1.00
1	194.200	-71.01	-13.00	58.01	-0.45	V	1	1.00
1	326.150	-68.78	-13.00	55.78	4.55	V	195.4	1.00
1	435.200	-69.54	-13.00	56.54	6.38	V	142.7	1.00

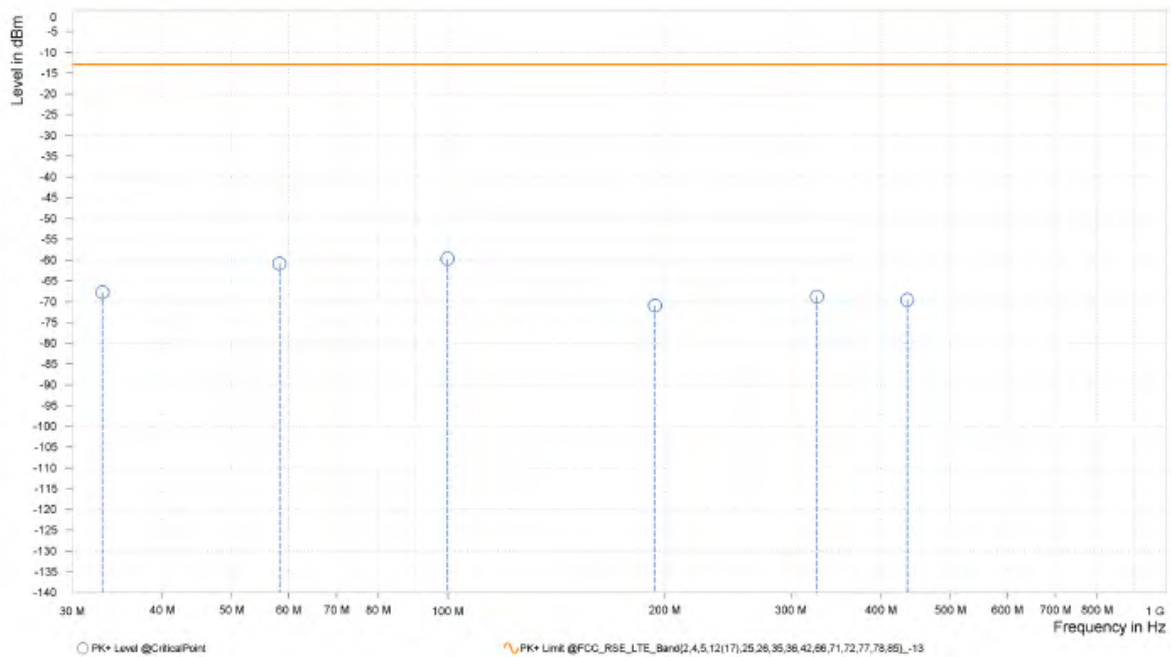



BUREAU VERITAS

Test Report No.: PSU-NQN2311090109RF03

ABOVE 1GHz

Note: For higher frequency, the emission is too low to be detected.

LTE BAND 12

CHANNEL BANDWIDTH: 1.4MHz / QPSK

CH 23017

MODE	TX channel 23017	FREQUENCY RANGE	Above 1000MHz
ENVIRONMENTAL CONDITIONS	23deg. C, 53%RH	INPUT POWER	AC 120V/60HZ
TESTED BY	Hanwen Xu		
ANTENNA POLARITY & TEST DISTANCE: HORIZONTAL AT 3 M			

Rg	Frequency [MHz]	PK+ Level [dBm]	PK+ Limit [dBm]	PK+ Margin [dB]	Correction [dB]	Polarization	Azimuth [deg]	Antenna Height [m]
2	1,398.000	-49.93	-13.00	36.93	13.76	H	1	1.00
2	2,097.000	-50.71	-13.00	37.71	18.94	H	1	1.00

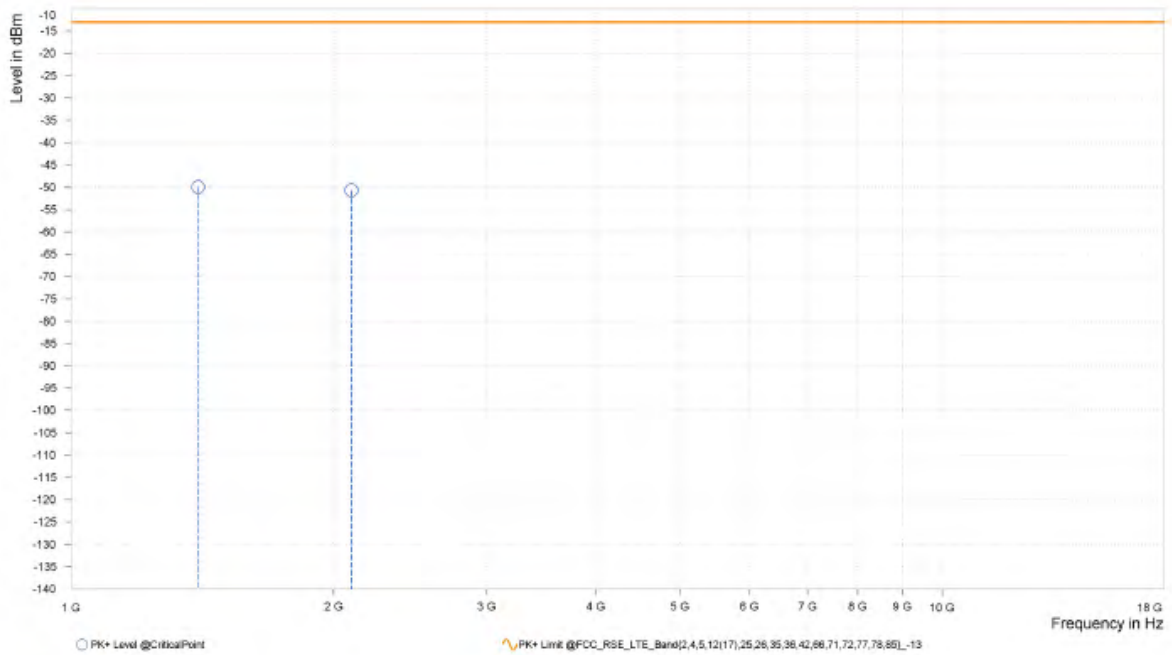



Test Report No.: PSU-NQN2311090109RF03

MODE	TX channel 23017	FREQUENCY RANGE	Above 1000MHz
ENVIRONMENTAL CONDITIONS	23deg. C, 53%RH	INPUT POWER	AC 120V/60HZ
TESTED BY	Hanwen Xu		
ANTENNA POLARITY & TEST DISTANCE: VERTICAL AT 3 M			

Rg	Frequency [MHz]	PK+ Level [dBm]	PK+ Limit [dBm]	PK+ Margin [dB]	Correction [dB]	Polarization	Azimuth [deg]	Antenna Height [m]
2	1,398.500	-43.12	-13.00	30.12	14.20	V	87.8	1.00
2	2,097.000	-48.75	-13.00	35.75	19.99	V	272.2	2.00

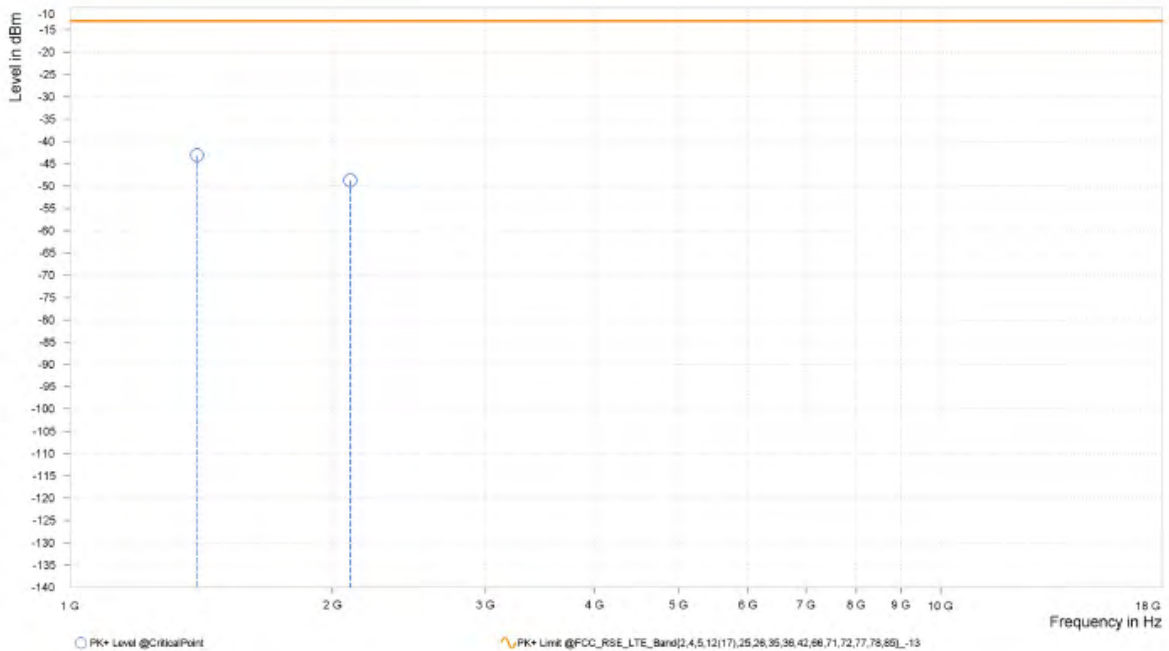



Test Report No.: PSU-NQN2311090109RF03

CH23095

MODE	TX channel 23095	FREQUENCY RANGE	Above 1000MHz
ENVIRONMENTAL CONDITIONS	23deg. C, 70%RH	INPUT POWER	AC 120V/60HZ
TESTED BY	Hanwen Xu		
ANTENNA POLARITY & TEST DISTANCE: HORIZONTAL AT 3 M			

Rg	Frequency [MHz]	PK+ Level [dBm]	PK+ Limit [dBm]	PK+ Margin [dB]	Correction [dB]	Polarization	Azimuth [deg]	Antenna Height [m]
2	1,414.000	-47.33	-13.00	34.33	14.41	H	1	1.00
2	2,121.000	-51.38	-13.00	38.38	19.32	H	354.2	1.00

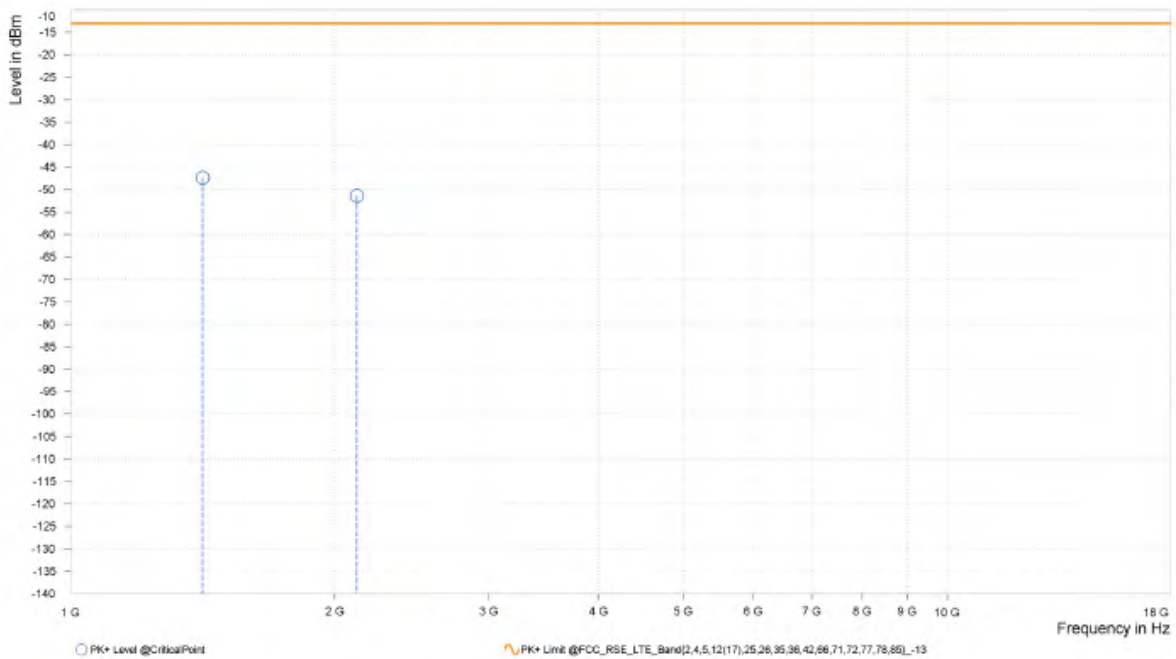



Test Report No.: PSU-NQN2311090109RF03

MODE	TX channel 23095	FREQUENCY RANGE	Above 1000MHz
ENVIRONMENTAL CONDITIONS	23deg. C, 70%RH	INPUT POWER	AC 120V/60HZ
TESTED BY	Hanwen Xu		
ANTENNA POLARITY & TEST DISTANCE: VERTICAL AT 3 M			

Rg	Frequency [MHz]	PK+ Level [dBm]	PK+ Limit [dBm]	PK+ Margin [dB]	Correction [dB]	Polarization	Azimuth [deg]	Antenna Height [m]
2	1,414.000	-41.86	-13.00	28.86	13.98	V	87.8	1.00
2	2,121.000	-49.07	-13.00	36.07	19.91	V	359.1	1.00

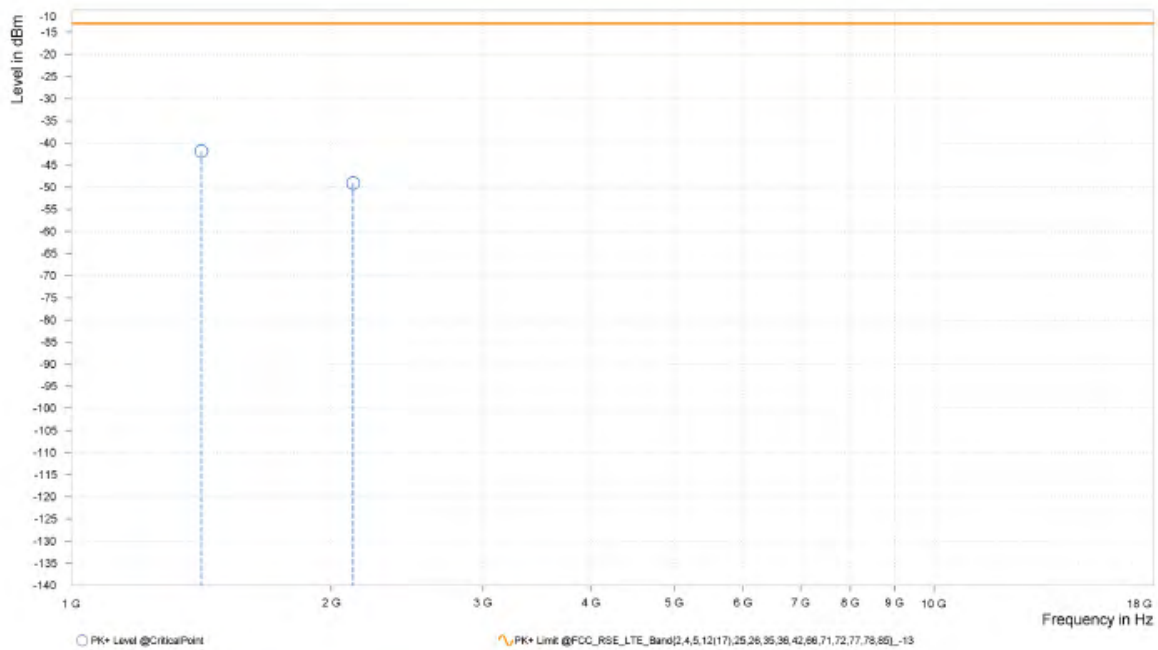



**BUREAU
VERITAS**

Test Report No.: PSU-NQN2311090109RF03

CH 23173

MODE	TX channel 23173	FREQUENCY RANGE	Above 1000MHz
ENVIRONMENTAL CONDITIONS	23deg. C, 53%RH	INPUT POWER	AC 120V/60HZ
TESTED BY	Hanwen Xu		
ANTENNA POLARITY & TEST DISTANCE: HORIZONTAL AT 3 M			

Rg	Frequency [MHz]	PK+ Level [dBm]	PK+ Limit [dBm]	PK+ Margin [dB]	Correction [dB]	Polarization	Azimuth [deg]	Antenna Height [m]
2	1,429.500	-46.32	-13.00	33.32	14.36	H	309.3	2.00
2	2,144.000	-50.25	-13.00	37.25	20.20	H	1	1.00

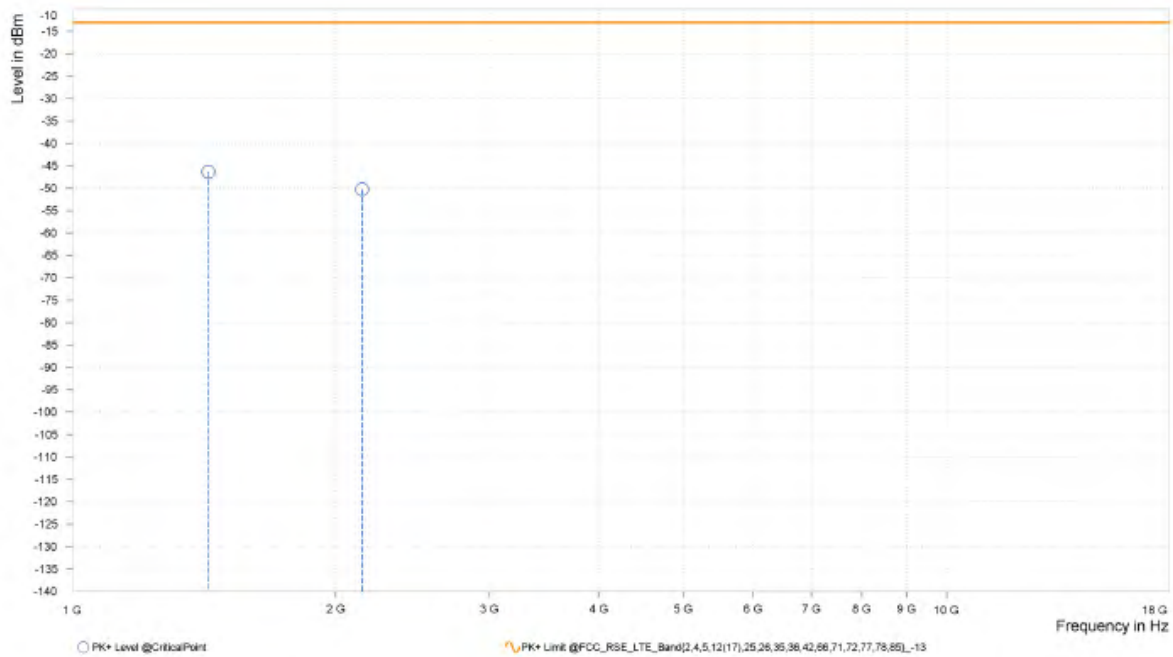



Test Report No.: PSU-NQN2311090109RF03

MODE	TX channel 23173	FREQUENCY RANGE	Above 1000MHz
ENVIRONMENTAL CONDITIONS	23deg. C, 53%RH	INPUT POWER	AC 120V/60HZ
TESTED BY	Hanwen Xu		
ANTENNA POLARITY & TEST DISTANCE: VERTICAL AT 3 M			

Rg	Frequency [MHz]	PK+ Level [dBm]	PK+ Limit [dBm]	PK+ Margin [dB]	Correction [dB]	Polarization	Azimuth [deg]	Antenna Height [m]
2	1,429.500	-41.11	-13.00	28.11	13.82	V	87.7	1.00
2	2,144.000	-49.93	-13.00	36.93	19.81	V	1	1.00

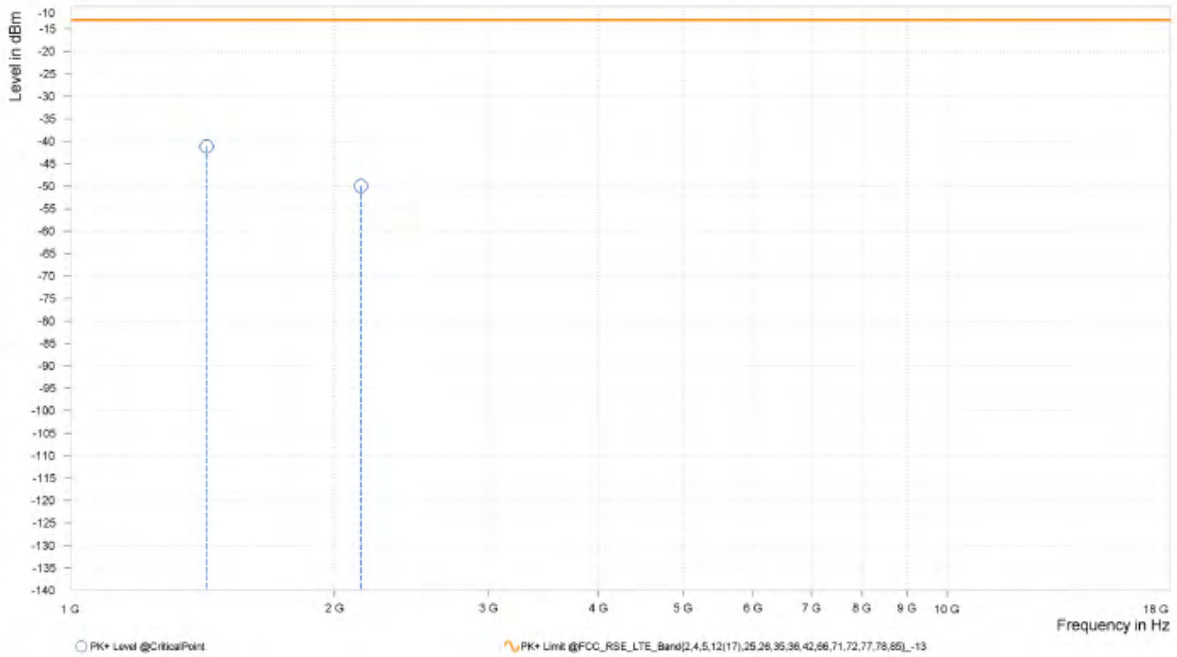



**BUREAU
VERITAS**

Test Report No.: PSU-NQN2311090109RF03

CHANNEL BANDWIDTH: 3MHz / QPSK

CH 23095

MODE	TX channel 23095	FREQUENCY RANGE	Above 1000MHz
ENVIRONMENTAL CONDITIONS	23deg. C, 53%RH	INPUT POWER	AC 120V/60HZ
TESTED BY	Hanwen Xu		
ANTENNA POLARITY & TEST DISTANCE: HORIZONTAL AT 3 M			

Rg	Frequency [MHz]	PK+ Level [dBm]	PK+ Limit [dBm]	PK+ Margin [dB]	Correction [dB]	Polarization	Azimuth [deg]	Antenna Height [m]
2	1,412.500	-46.89	-13.00	33.89	14.34	H	359.1	1.00
2	2,118.500	-51.79	-13.00	38.79	19.34	H	5.8	2.00

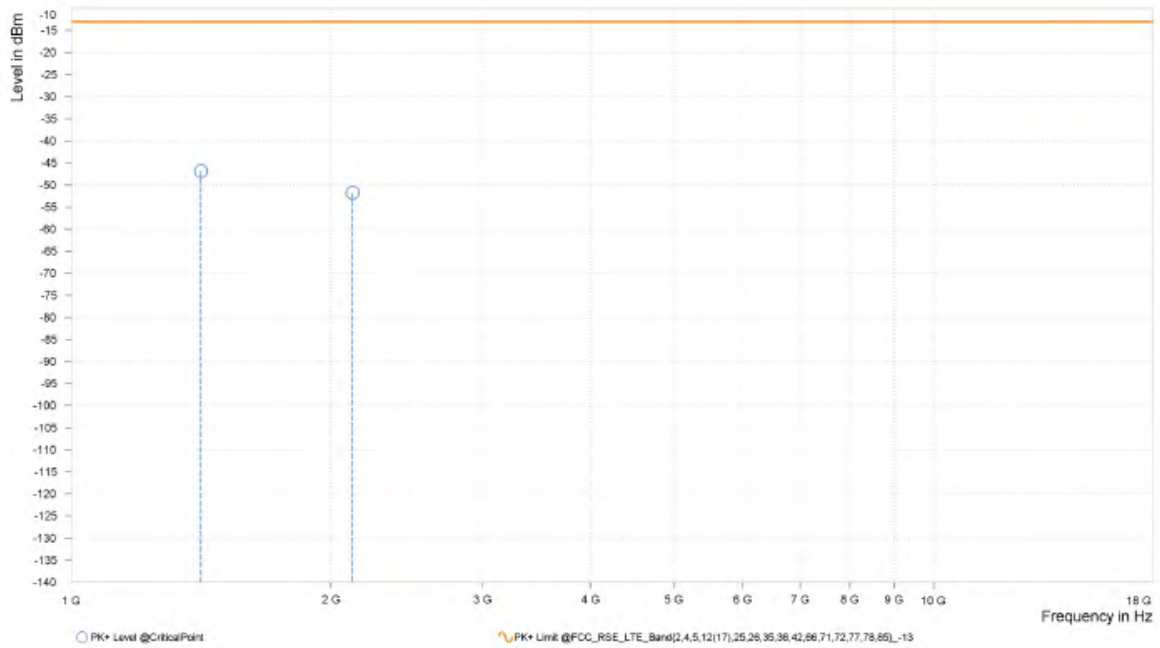



Test Report No.: PSU-NQN2311090109RF03

MODE	TX channel 23095	FREQUENCY RANGE	Above 1000MHz
ENVIRONMENTAL CONDITIONS	23deg. C, 53%RH	INPUT POWER	AC 120V/60HZ
TESTED BY	Hanwen Xu		
ANTENNA POLARITY & TEST DISTANCE: VERTICAL AT 3 M			

Rg	Frequency [MHz]	PK+ Level [dBm]	PK+ Limit [dBm]	PK+ Margin [dB]	Correction [dB]	Polarization	Azimuth [deg]	Antenna Height [m]
2	1,412.500	-42.24	-13.00	29.24	14.02	V	85.3	1.00
2	2,118.500	-49.44	-13.00	36.44	19.95	V	359	2.00

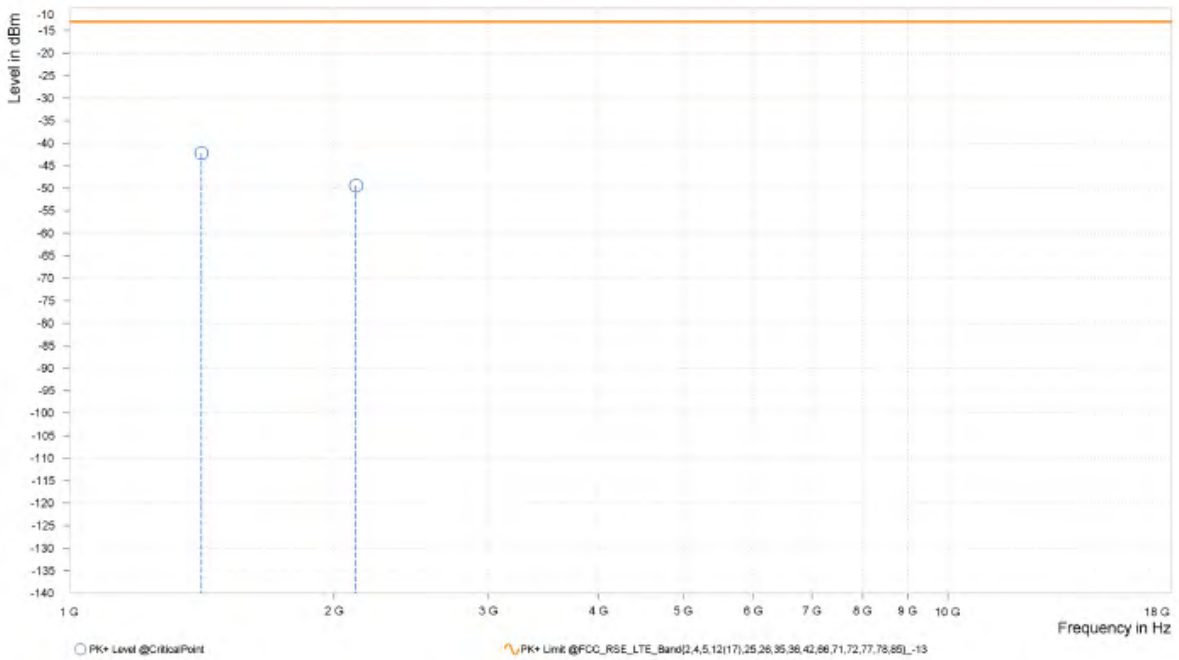



Test Report No.: PSU-NQN2311090109RF03

CHANNEL BANDWIDTH: 5MHz / QPSK

MODE	TX channel 23095	FREQUENCY RANGE	Above 1000MHz
ENVIRONMENTAL CONDITIONS	23deg. C, 70%RH	INPUT POWER	AC 120V/60HZ
TESTED BY	Hanwen Xu		
ANTENNA POLARITY & TEST DISTANCE: HORIZONTAL AT 3 M			

Rg	Frequency [MHz]	PK+ Level [dBm]	PK+ Limit [dBm]	PK+ Margin [dB]	Correction [dB]	Polarization	Azimuth [deg]	Antenna Height [m]
2	1,410.500	-48.92	-13.00	35.92	14.26	H	1	1.00
2	2,116.000	-52.53	-13.00	39.53	19.35	H	1	2.00

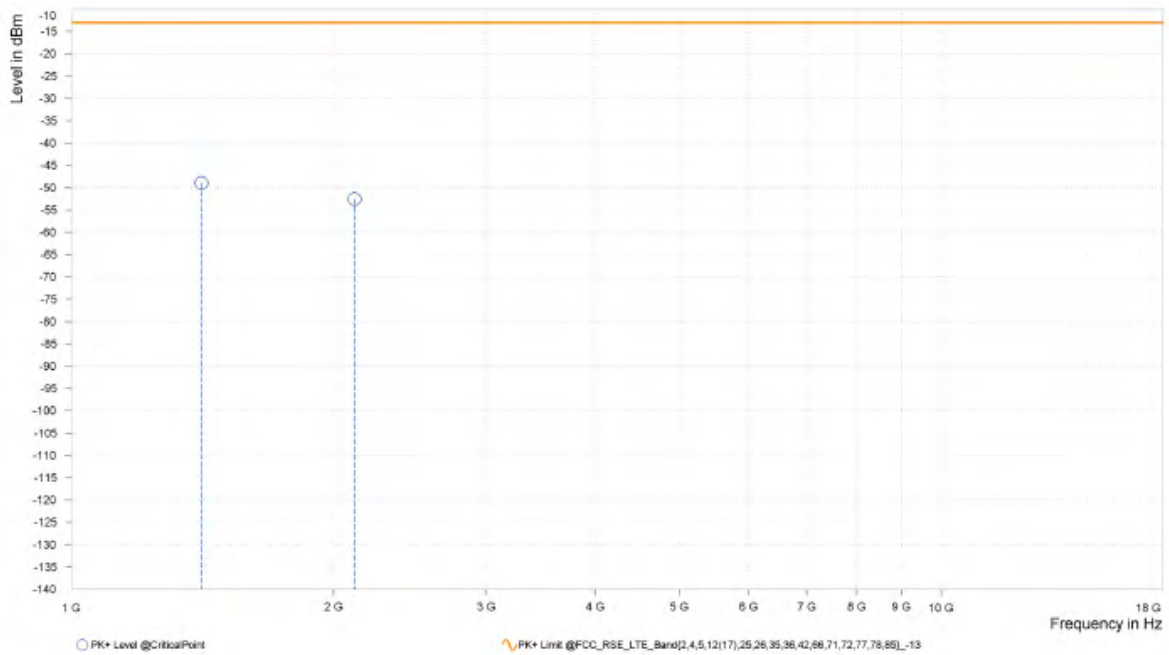



Test Report No.: PSU-NQN2311090109RF03

MODE	TX channel 23095	FREQUENCY RANGE	Above 1000MHz
ENVIRONMENTAL CONDITIONS	23deg. C, 70%RH	INPUT POWER	AC 120V/60HZ
TESTED BY	Hanwen Xu		
ANTENNA POLARITY & TEST DISTANCE: VERTICAL AT 3 M			

Rg	Frequency [MHz]	PK+ Level [dBm]	PK+ Limit [dBm]	PK+ Margin [dB]	Correction [dB]	Polarization	Azimuth [deg]	Antenna Height [m]
2	1,410.500	-43.05	-13.00	30.05	14.08	V	89	1.00
2	2,116.000	-48.96	-13.00	35.96	19.98	V	89	1.00

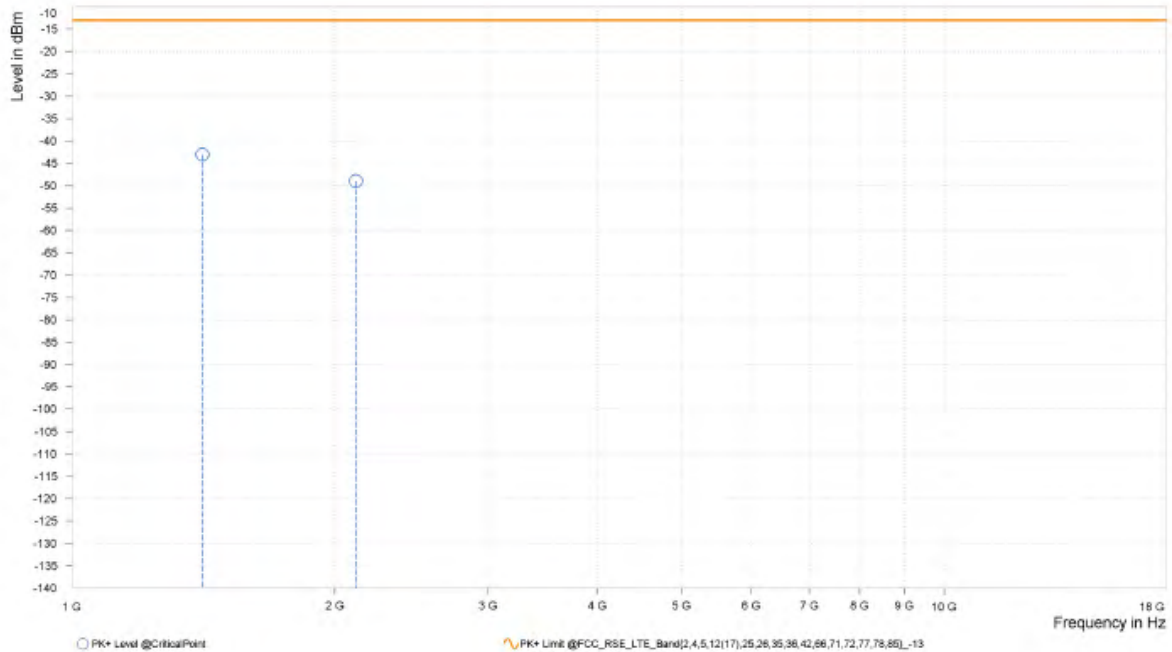



Test Report No.: PSU-NQN2311090109RF03

CHANNEL BANDWIDTH: 10MHz / QPSK

MODE	TX channel 23095	FREQUENCY RANGE	Above 1000MHz
ENVIRONMENTAL CONDITIONS	23deg. C, 70%RH	INPUT POWER	AC 120V/60HZ
TESTED BY	Hanwen Xu		
ANTENNA POLARITY & TEST DISTANCE: HORIZONTAL AT 3 M			

Rg	Frequency [MHz]	PK+ Level [dBm]	PK+ Limit [dBm]	PK+ Margin [dB]	Correction [dB]	Polarization	Azimuth [deg]	Antenna Height [m]
2	1,406.000	-49.64	-13.00	36.64	14.06	H	309.3	2.00
2	2,109.000	-51.76	-13.00	38.76	19.38	H	1	1.00

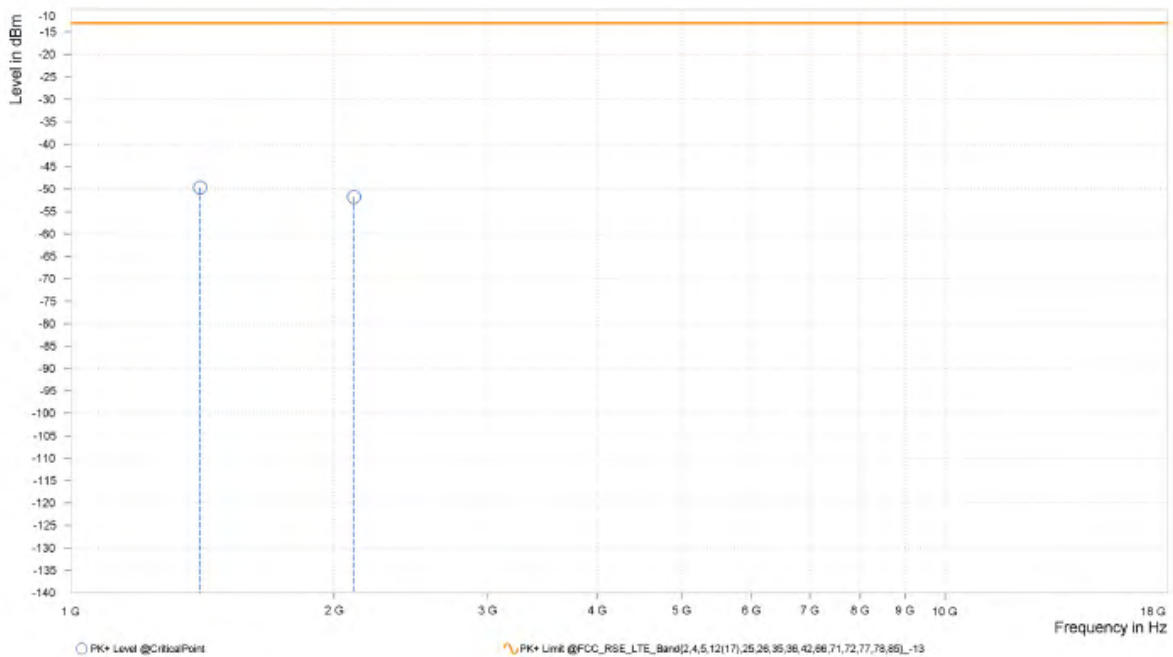



Test Report No.: PSU-NQN2311090109RF03

MODE	TX channel 23095	FREQUENCY RANGE	Above 1000MHz
ENVIRONMENTAL CONDITIONS	23deg. C, 70%RH	INPUT POWER	AC 120V/60HZ
TESTED BY	Hanwen Xu		
ANTENNA POLARITY & TEST DISTANCE: VERTICAL AT 3 M			

Rg	Frequency [MHz]	PK+ Level [dBm]	PK+ Limit [dBm]	PK+ Margin [dB]	Correction [dB]	Polarization	Azimuth [deg]	Antenna Height [m]
2	1,406.000	-42.32	-13.00	29.32	14.19	V	87.7	1.00
2	2,109.000	-48.83	-13.00	35.83	20.08	V	87.7	1.00

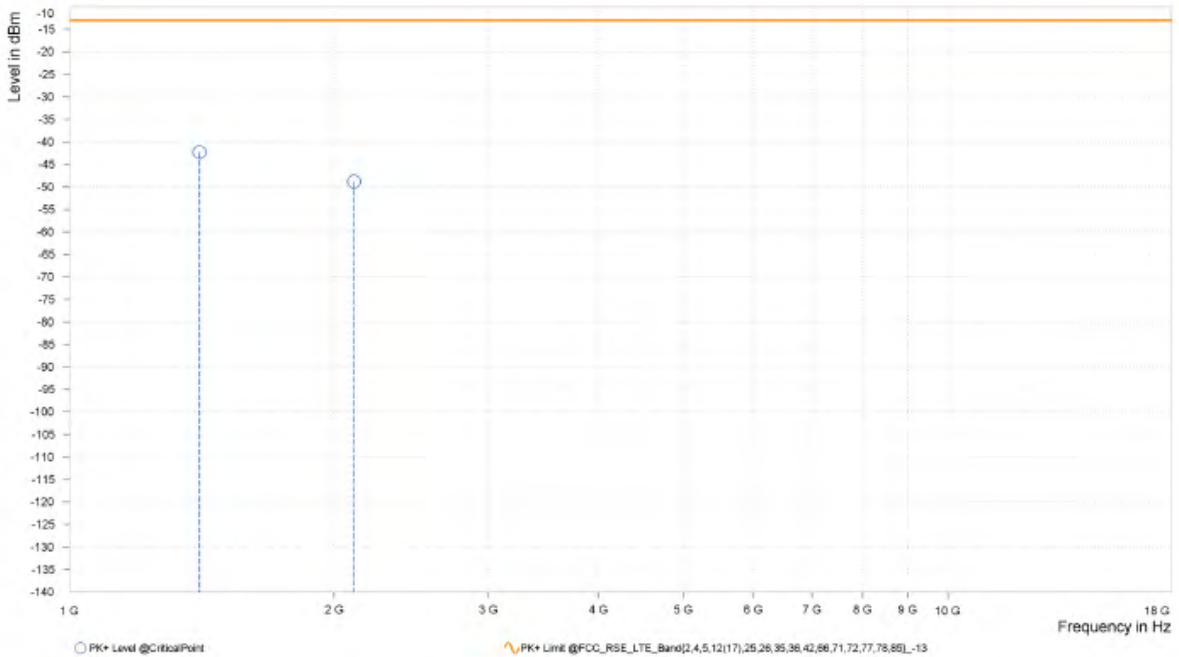



Test Report No.: PSU-NQN2311090109RF03

LTE Band 13

CHANNEL BANDWIDTH: 5MHz / QPSK

CH23205

MODE	TX channel 23205	FREQUENCY RANGE	Above 1000MHz
ENVIRONMENTAL CONDITIONS	23deg. C, 70%RH	INPUT POWER	AC 120V/60Hz
TESTED BY	Hanwen Xu		
ANTENNA POLARITY & TEST DISTANCE: HORIZONTAL AT 3 M			

Rg	Frequency [MHz]	PK+ Level [dBm]	PK+ Limit [dBm]	PK+ Margin [dB]	Correction [dB]	Polarization	Azimuth [deg]	Antenna Height [m]
2	1,554.500	-46.70	-13.00	33.70	13.36	H	51.8	1.00
3	2,332.000	-49.70	-13.00	36.70	20.16	H	306.4	1.00

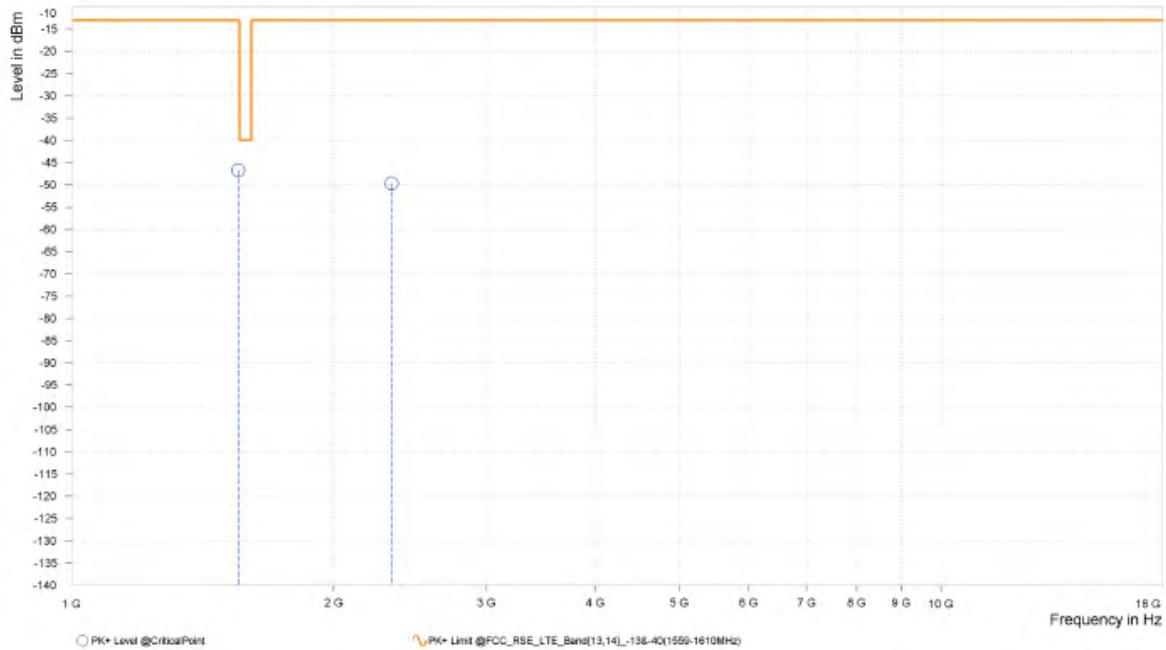



Test Report No.: PSU-NQN2311090109RF03

MODE	TX channel 23205	FREQUENCY RANGE	Above 1000MHz
ENVIRONMENTAL CONDITIONS	23deg. C, 70%RH	INPUT POWER	AC 120V/60Hz
TESTED BY	Hanwen Xu		
ANTENNA POLARITY & TEST DISTANCE: VERTICAL AT 3 M			

Rg	Frequency [MHz]	PK+ Level [dBm]	PK+ Limit [dBm]	PK+ Margin [dB]	Correction [dB]	Polarization	Azimuth [deg]	Antenna Height [m]
2	1,554.500	-44.70	-13.00	31.70	14.69	V	1	1.00
3	2,332.000	-48.31	-13.00	35.31	20.76	V	164.2	1.00

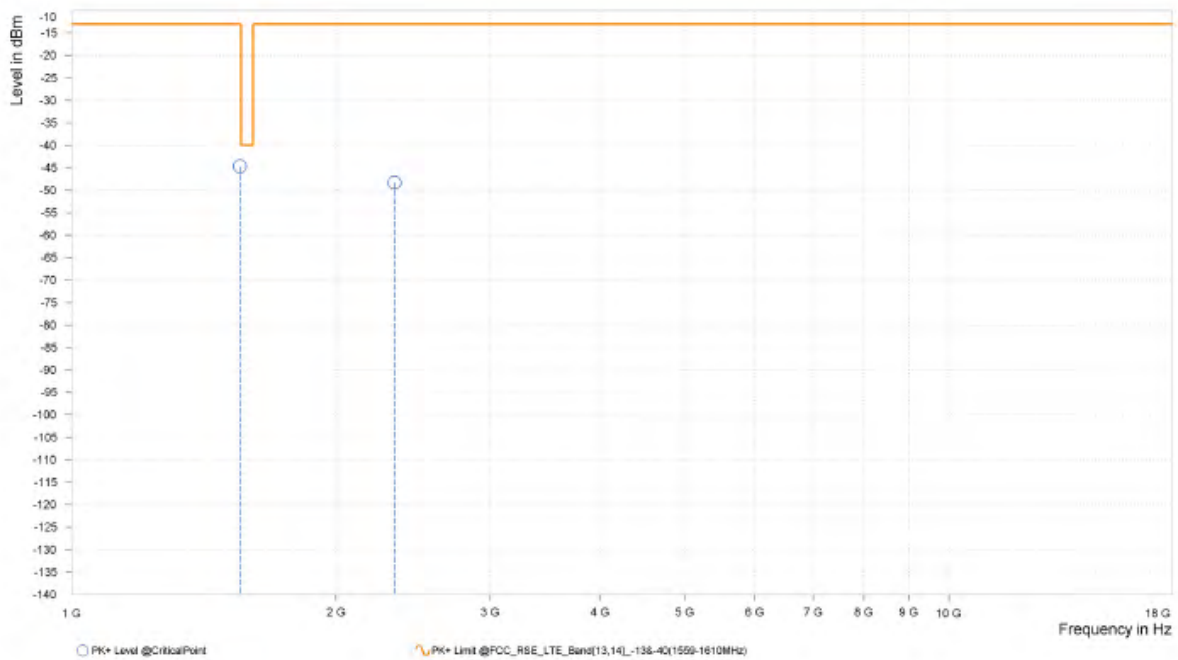



Test Report No.: PSU-NQN2311090109RF03

CH23230

MODE	TX channel 23230	FREQUENCY RANGE	Above 1000MHz
ENVIRONMENTAL CONDITIONS	23deg. C, 70%RH	INPUT POWER	AC 120V/60Hz
TESTED BY	Hanwen Xu		
ANTENNA POLARITY & TEST DISTANCE: HORIZONTAL AT 3 M			

Rg	Frequency [MHz]	PK+ Level [dBm]	PK+ Limit [dBm]	PK+ Margin [dB]	Correction [dB]	Polarization	Azimuth [deg]	Antenna Height [m]
2	1,559.500	-47.11	-40.00	7.11	13.33	H	51.9	1.00
3	2,339.000	-49.75	-13.00	36.75	20.38	H	0.9	2.00

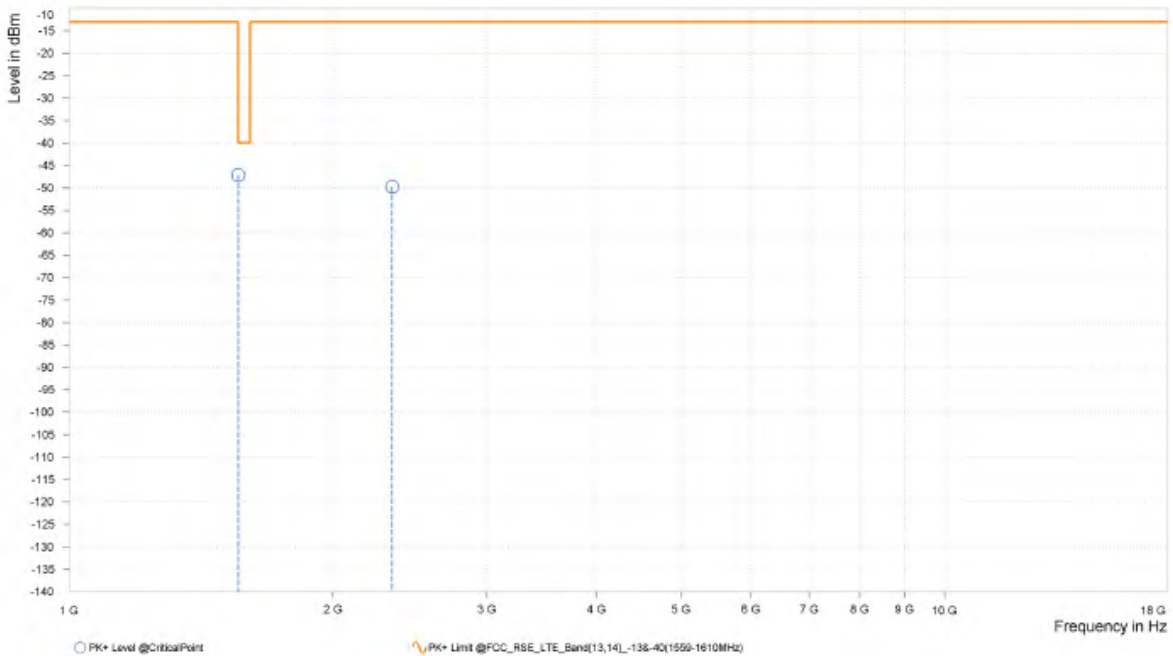



Test Report No.: PSU-NQN2311090109RF03

MODE	TX channel 23230	FREQUENCY RANGE	Above 1000MHz
ENVIRONMENTAL CONDITIONS	23deg. C, 70%RH	INPUT POWER	AC 120V/60Hz
TESTED BY	Hanwen Xu		
ANTENNA POLARITY & TEST DISTANCE: VERTICAL AT 3 M			

Rg	Frequency [MHz]	PK+ Level [dBm]	PK+ Limit [dBm]	PK+ Margin [dB]	Correction [dB]	Polarization	Azimuth [deg]	Antenna Height [m]
2	1,559.500	-44.76	-40.00	4.76	14.72	V	0.9	2.00
3	2,339.000	-48.37	-13.00	35.37	20.79	V	195.7	2.00

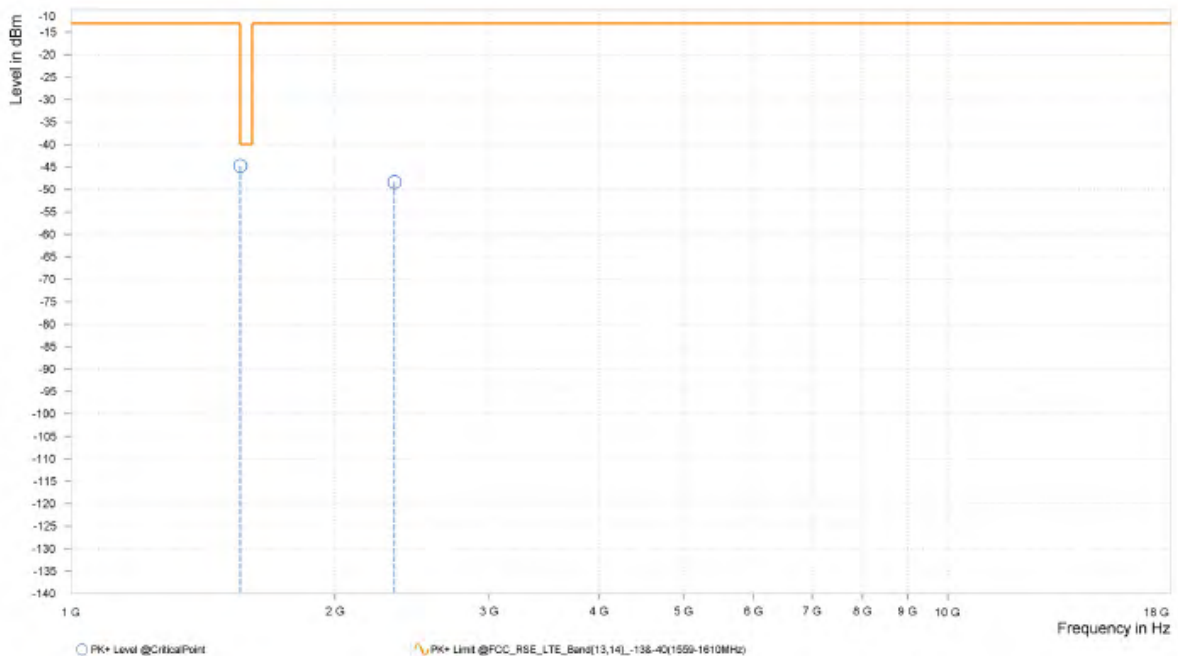



Test Report No.: PSU-NQN2311090109RF03

CH23255

MODE	TX channel 23255	FREQUENCY RANGE	Above 1000MHz
ENVIRONMENTAL CONDITIONS	23deg. C, 70%RH	INPUT POWER	AC 120V/60Hz
TESTED BY	Hanwen Xu		
ANTENNA POLARITY & TEST DISTANCE: HORIZONTAL AT 3 M			

Rg	Frequency [MHz]	PK+ Level [dBm]	PK+ Limit [dBm]	PK+ Margin [dB]	Correction [dB]	Polarization	Azimuth [deg]	Antenna Height [m]
2	1,564.500	-47.81	-40.00	7.81	13.31	H	56.7	1.00
3	2,347.000	-48.92	-13.00	35.92	20.70	H	0.9	2.00

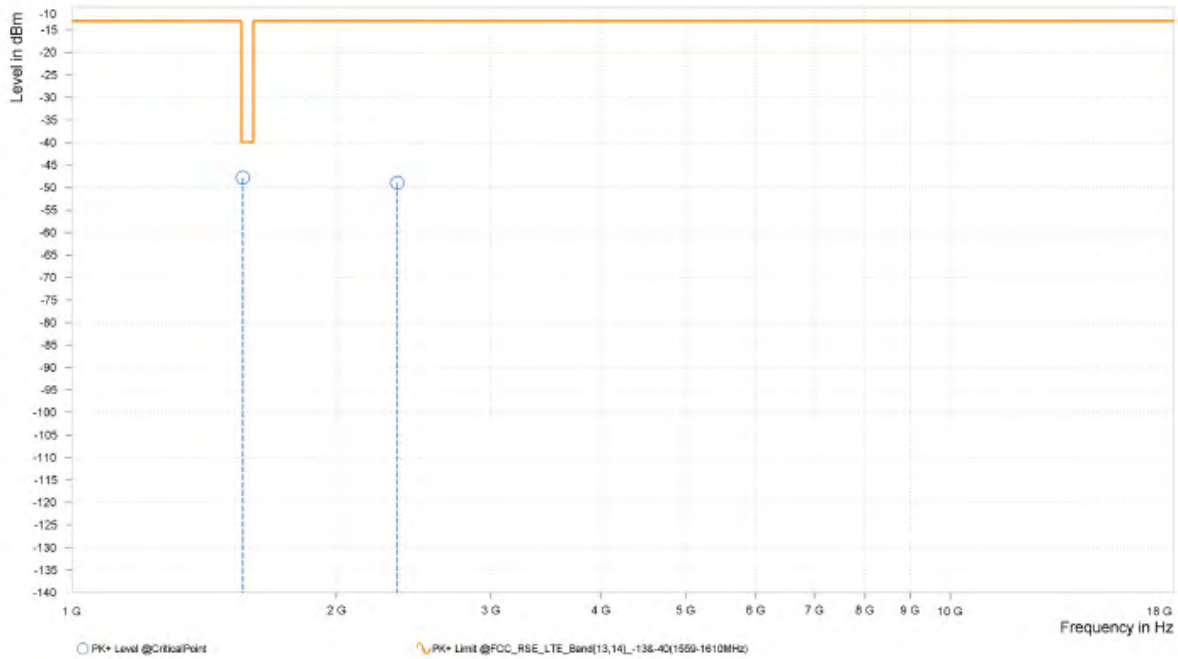



Test Report No.: PSU-NQN2311090109RF03

MODE	TX channel 23255	FREQUENCY RANGE	Above 1000MHz
ENVIRONMENTAL CONDITIONS	23deg. C, 70%RH	INPUT POWER	AC 120V/60Hz
TESTED BY	Hanwen Xu		
ANTENNA POLARITY & TEST DISTANCE: VERTICAL AT 3 M			

Rg	Frequency [MHz]	PK+ Level [dBm]	PK+ Limit [dBm]	PK+ Margin [dB]	Correction [dB]	Polarization	Azimuth [deg]	Antenna Height [m]
2	1,564.500	-42.20	-40.00	2.20	14.73	V	1	1.00
3	2,347.000	-48.06	-13.00	35.06	20.88	V	170.2	1.00

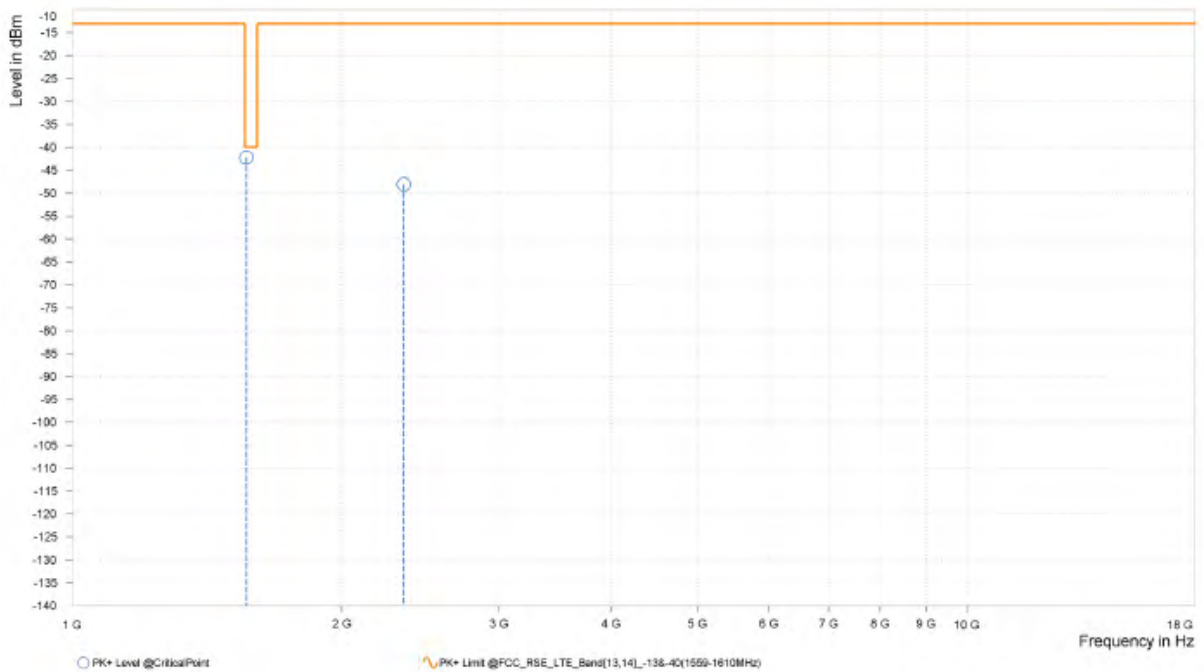



Test Report No.: PSU-NQN2311090109RF03

LTE Band 13

CHANNEL BANDWIDTH: 10MHz / QPSK

CH23230

MODE	TX channel 23230	FREQUENCY RANGE	Above 1000MHz
ENVIRONMENTAL CONDITIONS	23deg. C, 70%RH	INPUT POWER	AC 120V/60Hz
TESTED BY	Hanwen Xu		
ANTENNA POLARITY & TEST DISTANCE: HORIZONTAL AT 3 M			

Rg	Frequency [MHz]	PK+ Level [dBm]	PK+ Limit [dBm]	PK+ Margin [dB]	Correction [dB]	Polarization	Azimuth [deg]	Antenna Height [m]
2	1,555.000	-47.73	-13.00	34.73	13.36	H	51.9	1.00
3	2,332.500	-49.29	-13.00	36.29	20.17	H	53.4	2.00

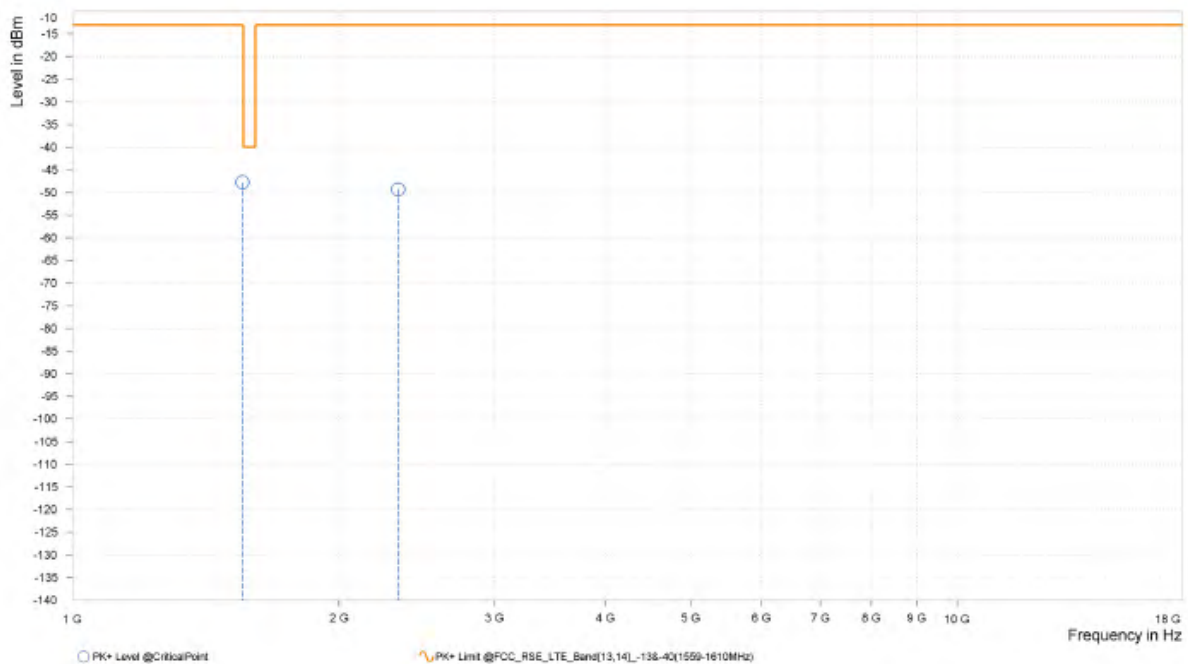



Test Report No.: PSU-NQN2311090109RF03

MODE	TX channel 23230	FREQUENCY RANGE	Above 1000MHz
ENVIRONMENTAL CONDITIONS	23deg. C, 70%RH	INPUT POWER	AC 120V/60Hz
TESTED BY	Hanwen Xu		
ANTENNA POLARITY & TEST DISTANCE: VERTICAL AT 3 M			

Rg	Frequency [MHz]	PK+ Level [dBm]	PK+ Limit [dBm]	PK+ Margin [dB]	Correction [dB]	Polarization	Azimuth [deg]	Antenna Height [m]
2	1,555.000	-45.05	-13.00	32.05	14.70	V	0.9	2.00
3	2,332.500	-48.28	-13.00	35.28	20.76	V	164.2	1.00

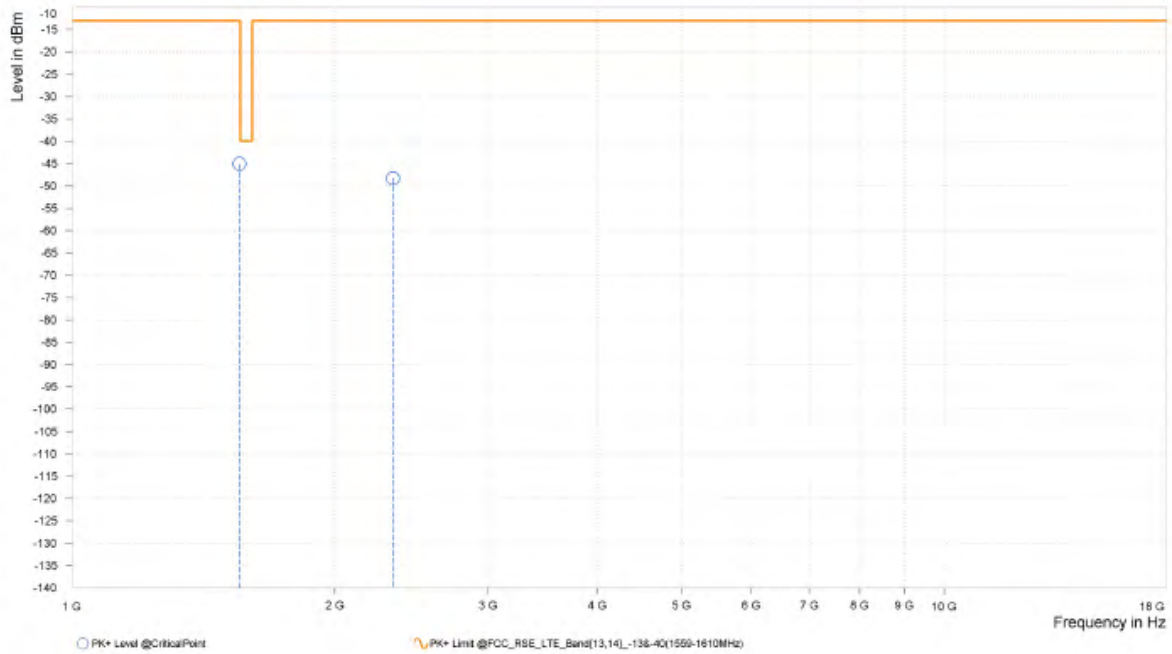

3.7 PEAK TO AVERAGE RATIO

3.7.1 LIMITS OF PEAK TO AVERAGE RATIO MEASUREMENT

In measuring transmissions in this band using an average power technique, the peak to-average ratio (PAR) of the transmission may not exceed 13 dB

3.7.2 TEST SETUP

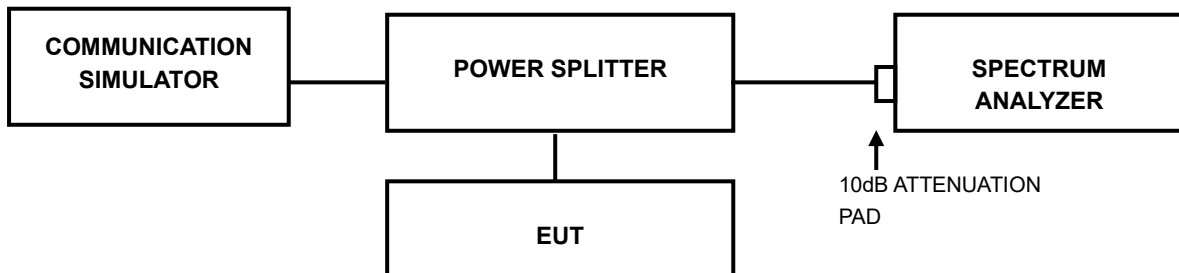

3.7.3 TEST PROCEDURES

1. Set resolution/measurement bandwidth \geq signal's occupied bandwidth;
2. Set the number of counts to a value that stabilizes the measured CCDF curve;
3. Record the maximum PAPR level associated with a probability of 0.1%.



Test Report No.: PSU-NQN2311090109RF03

3.7.4 TEST RESULTS

Please Refer to Appendix Of this test report.



Test Report No.: PSU-NQN2311090109RF03

4 INFORMATION ON THE TESTING LABORATORIES

We, Huarui 7layers High Technology (Suzhou) Co., Ltd. ,were founded in 2020 to provide our best service in EMC, Radio, Telecom and Safety consultation. Our laboratories are accredited and approved according to ISO/IEC 17025.

If you have any comments, please feel free to contact us at the following:

Suzhou EMC/RF Lab:

Tel: +86 (0557) 368 1008



Test Report No.: PSU-NQN2311090109RF03

5 MODIFICATIONS RECORDERS FOR ENGINEERING CHANGES TO THE EUT BY THE LAB

No any modifications are made to the EUT by the lab during the test.



6 APPENDIX

LTE BAND12

PEAK-TO-AVERAGE RATIO(CCDF)

Test Result

Band	Bandwidth	Modulation	Channel	RB Configuration	Result(dB)	Limit(dB)	Verdict
Band12	10MHz	QPSK	23060	1RB#0	4.58	13	PASS
Band12	10MHz	QPSK	23060	50RB#0	5.06	13	PASS
Band12	10MHz	16QAM	23060	1RB#0	5.10	13	PASS
Band12	10MHz	16QAM	23060	50RB#0	5.88	13	PASS
Band12	10MHz	64QAM	23060	1RB#0	5.66	13	PASS
Band12	10MHz	64QAM	23060	50RB#0	6.48	13	PASS
Band12	10MHz	QPSK	23095	1RB#0	4.80	13	PASS
Band12	10MHz	QPSK	23095	50RB#0	5.06	13	PASS
Band12	10MHz	16QAM	23095	1RB#0	5.78	13	PASS
Band12	10MHz	16QAM	23095	50RB#0	5.96	13	PASS
Band12	10MHz	64QAM	23095	1RB#0	6.46	13	PASS
Band12	10MHz	64QAM	23095	50RB#0	6.46	13	PASS
Band12	10MHz	QPSK	23130	1RB#0	4.56	13	PASS
Band12	10MHz	QPSK	23130	50RB#0	4.92	13	PASS
Band12	10MHz	16QAM	23130	1RB#0	5.02	13	PASS
Band12	10MHz	16QAM	23130	50RB#0	5.82	13	PASS
Band12	10MHz	64QAM	23130	1RB#0	6.06	13	PASS
Band12	10MHz	64QAM	23130	50RB#0	6.30	13	PASS



Test Report No.: PSU-NQN2311090109RF03

Test Graphs

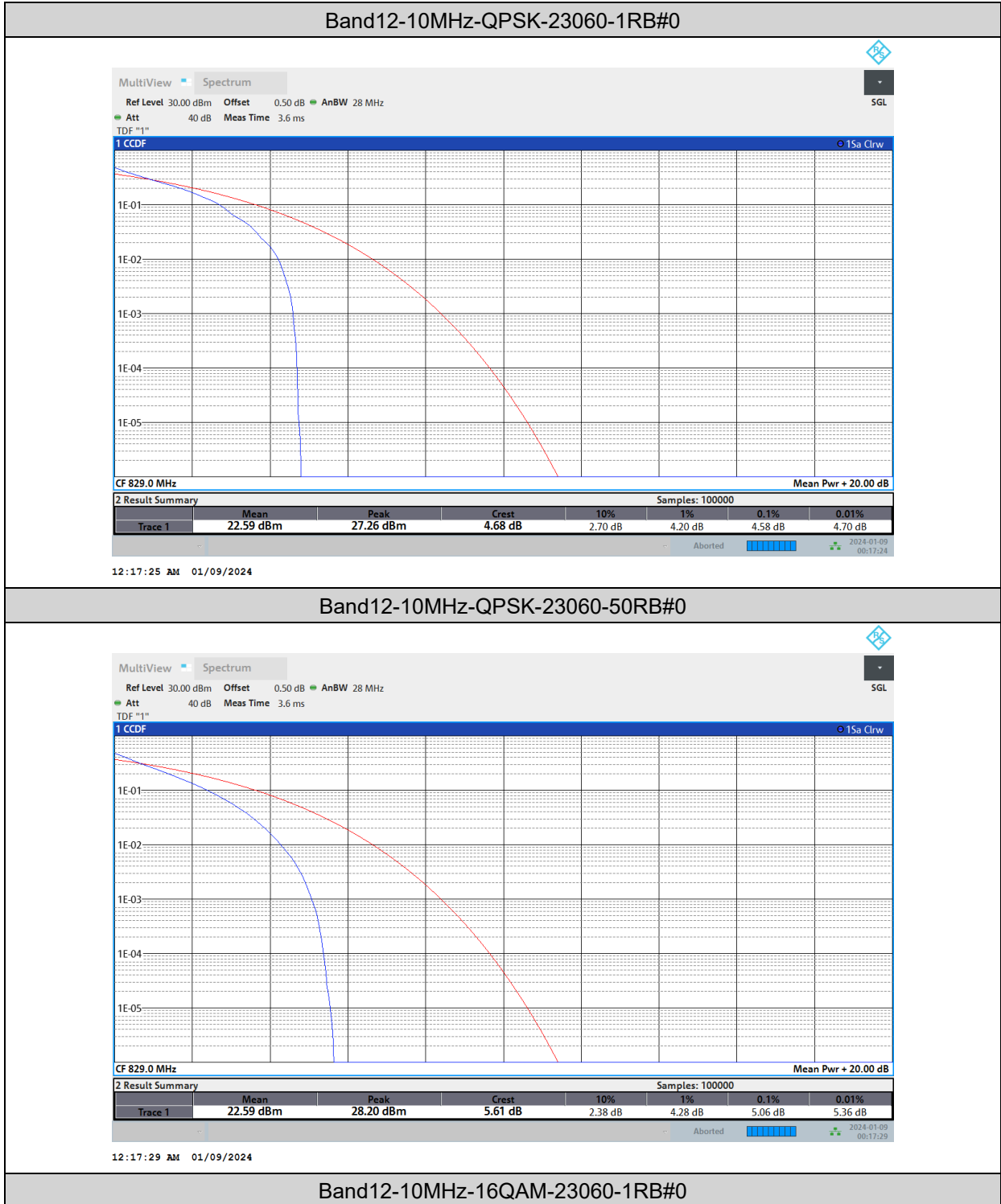



BUREAU VERITAS

Test Report No.: PSU-NQN2311090109RF03

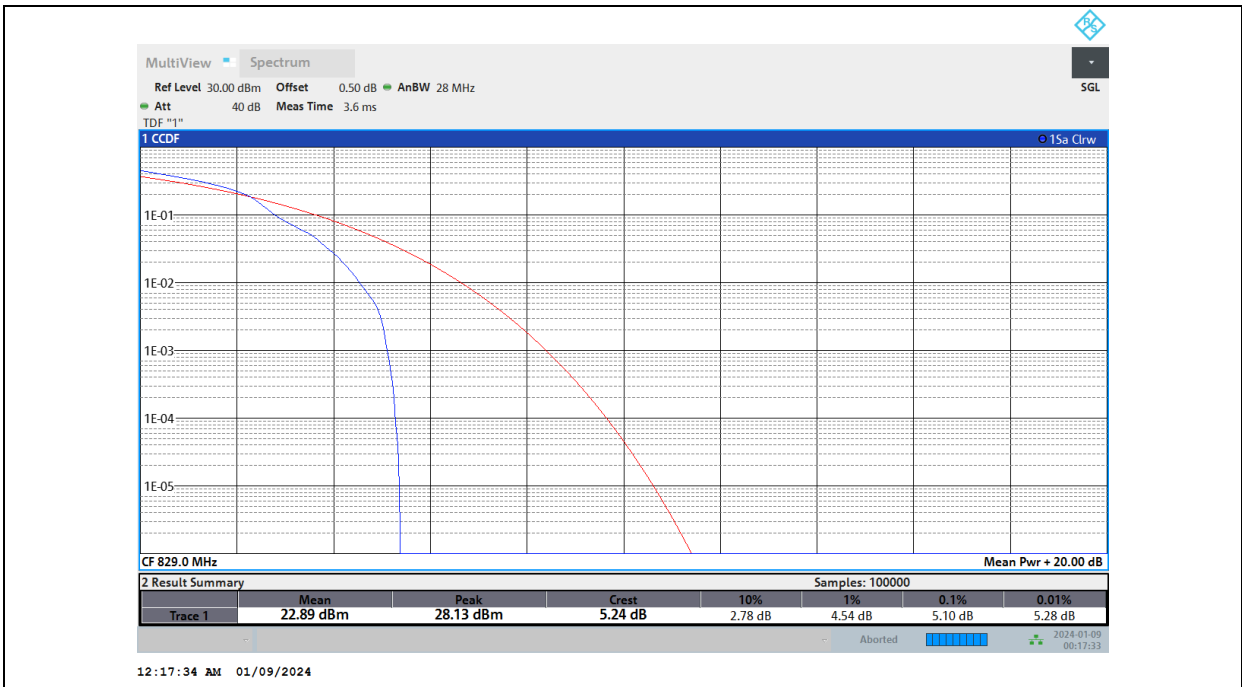

Band12-10MHz-16QAM-23060-50RB#0

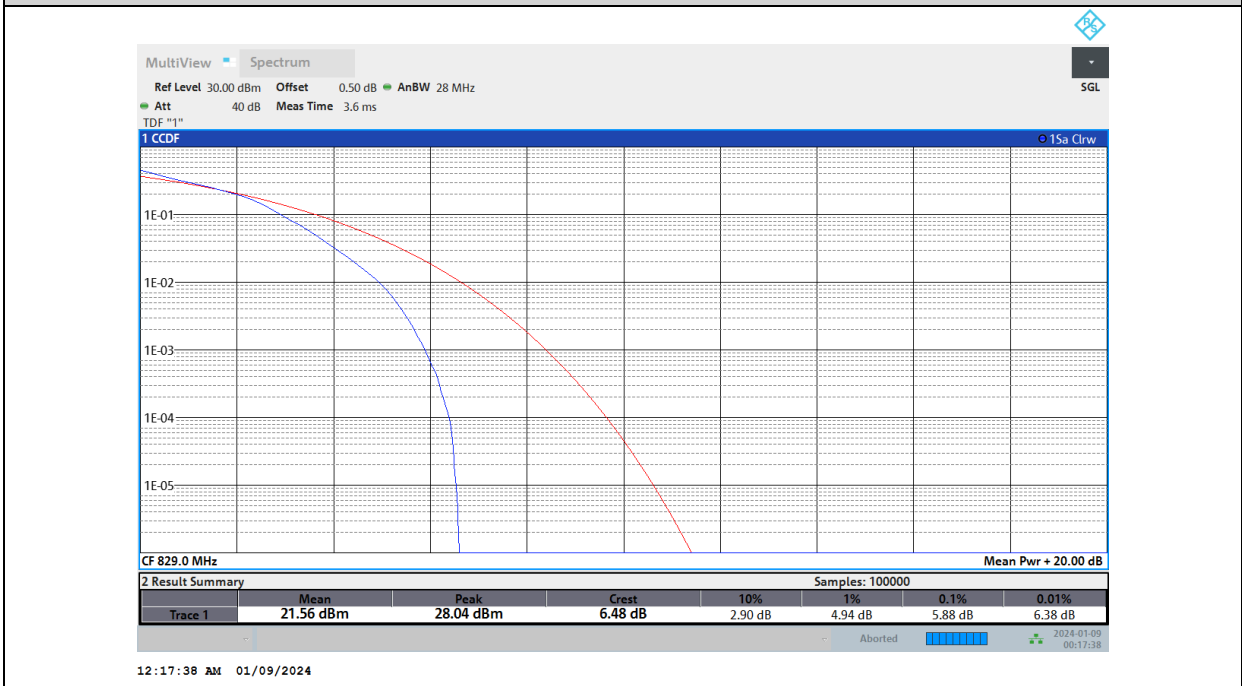

Band12-10MHz-64QAM-23060-1RB#0



BUREAU VERITAS

Test Report No.: PSU-NQN2311090109RF03

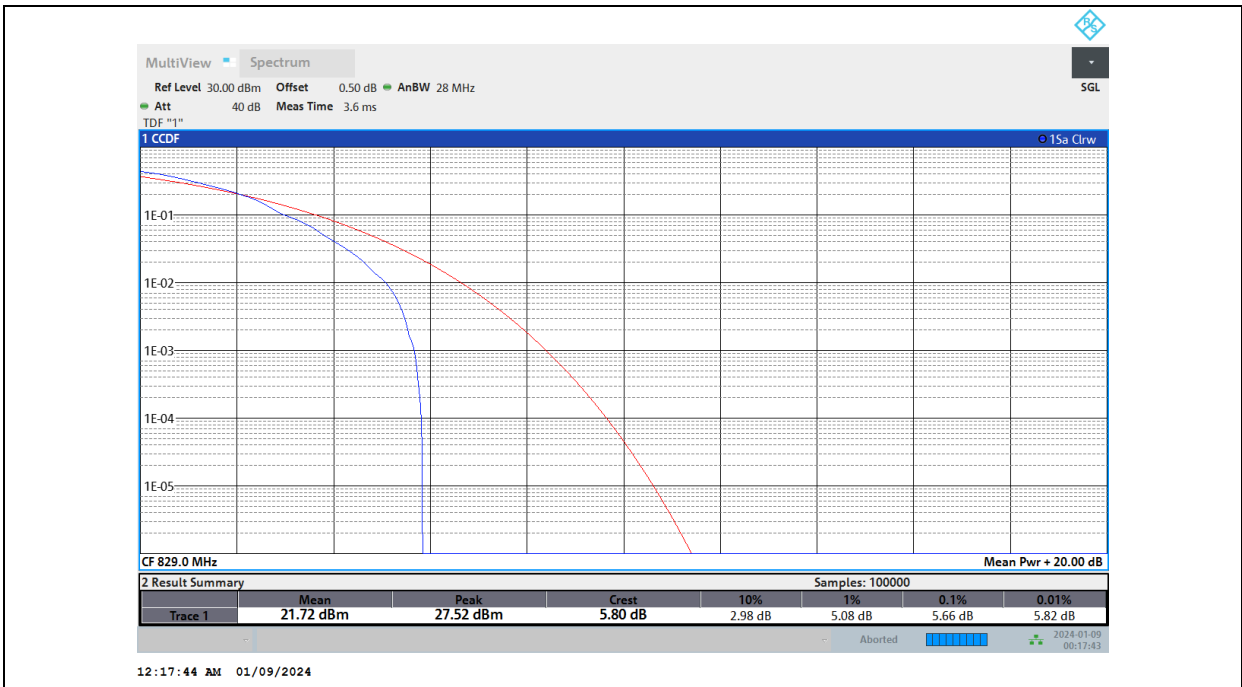

Band12-10MHz-64QAM-23060-50RB#0

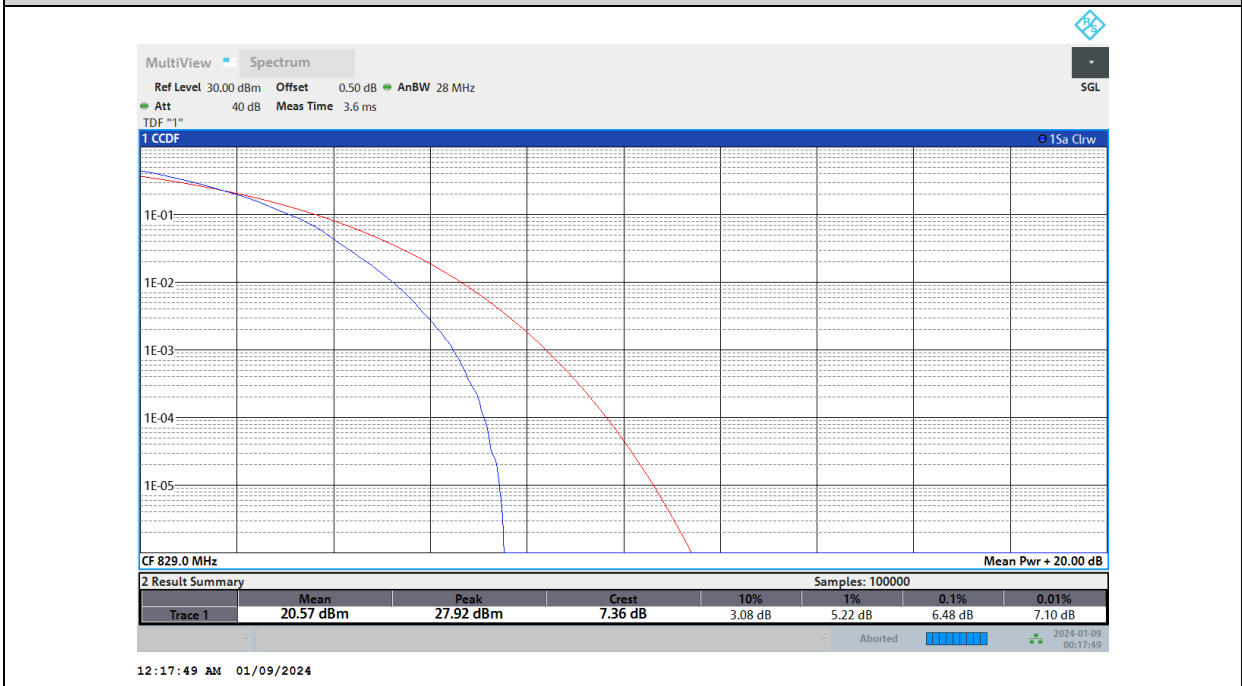

Band12-10MHz-QPSK-23095-1RB#0



BUREAU VERITAS

Test Report No.: PSU-NQN2311090109RF03

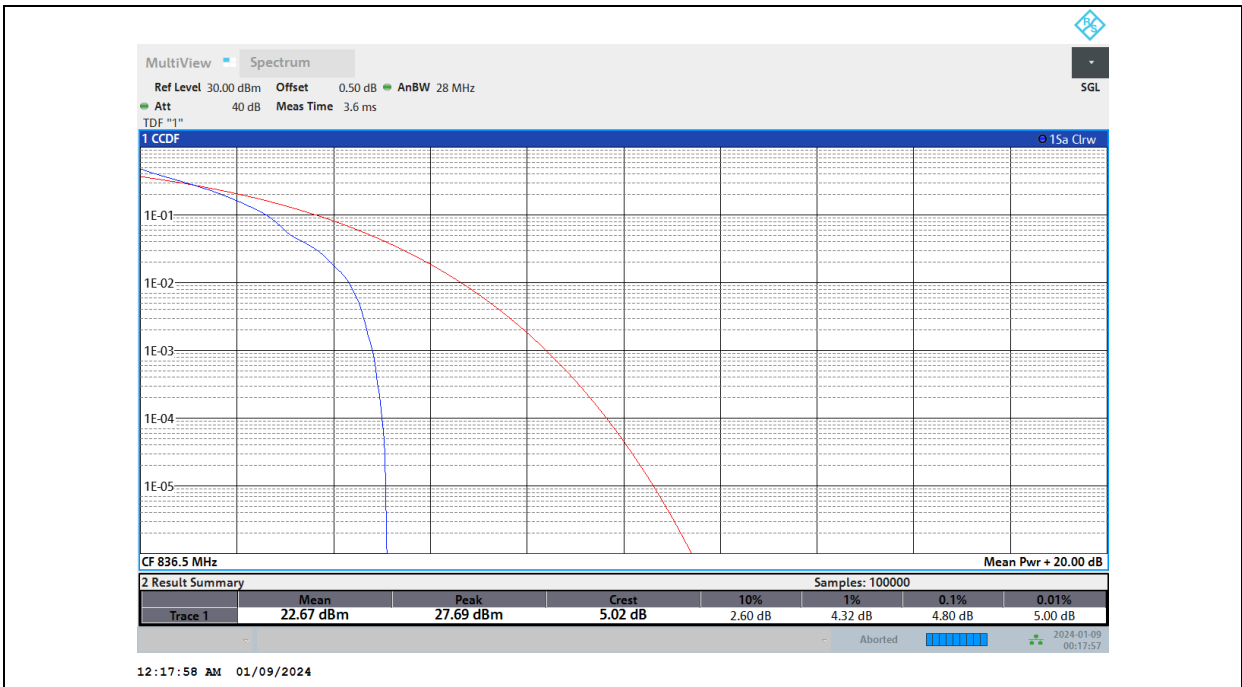

Band12-10MHz-QPSK-23095-50RB#0

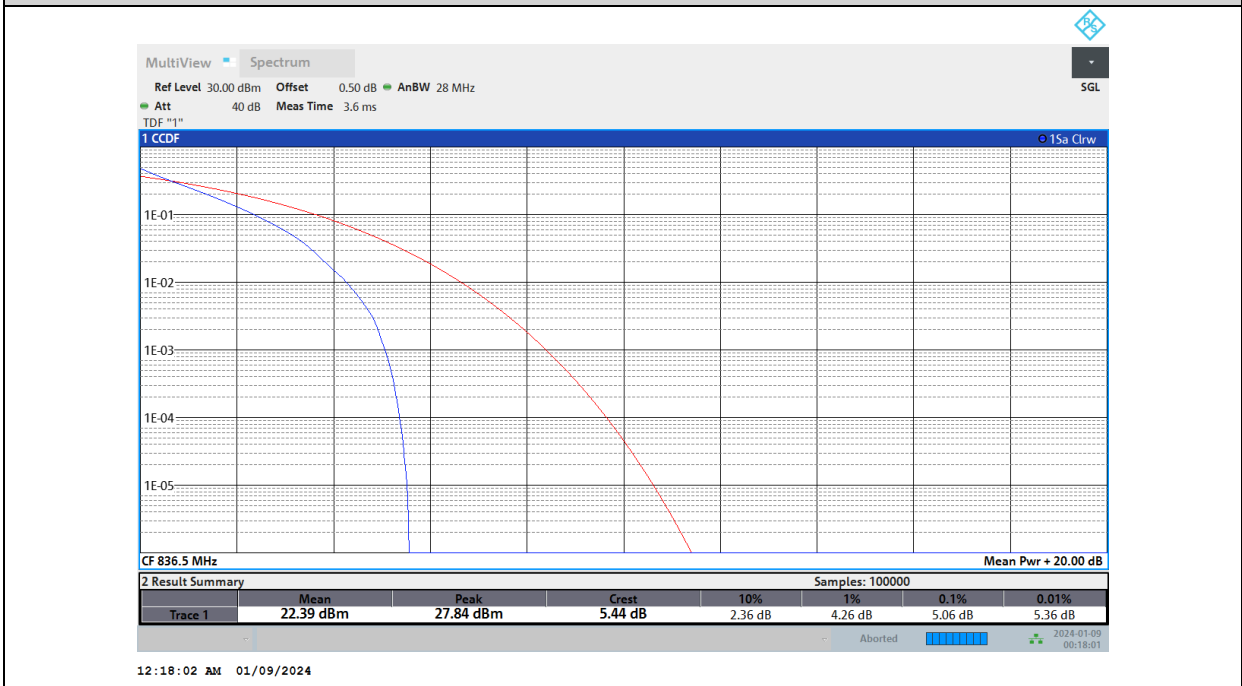

Band12-10MHz-16QAM-23095-1RB#0



BUREAU VERITAS

Test Report No.: PSU-NQN2311090109RF03

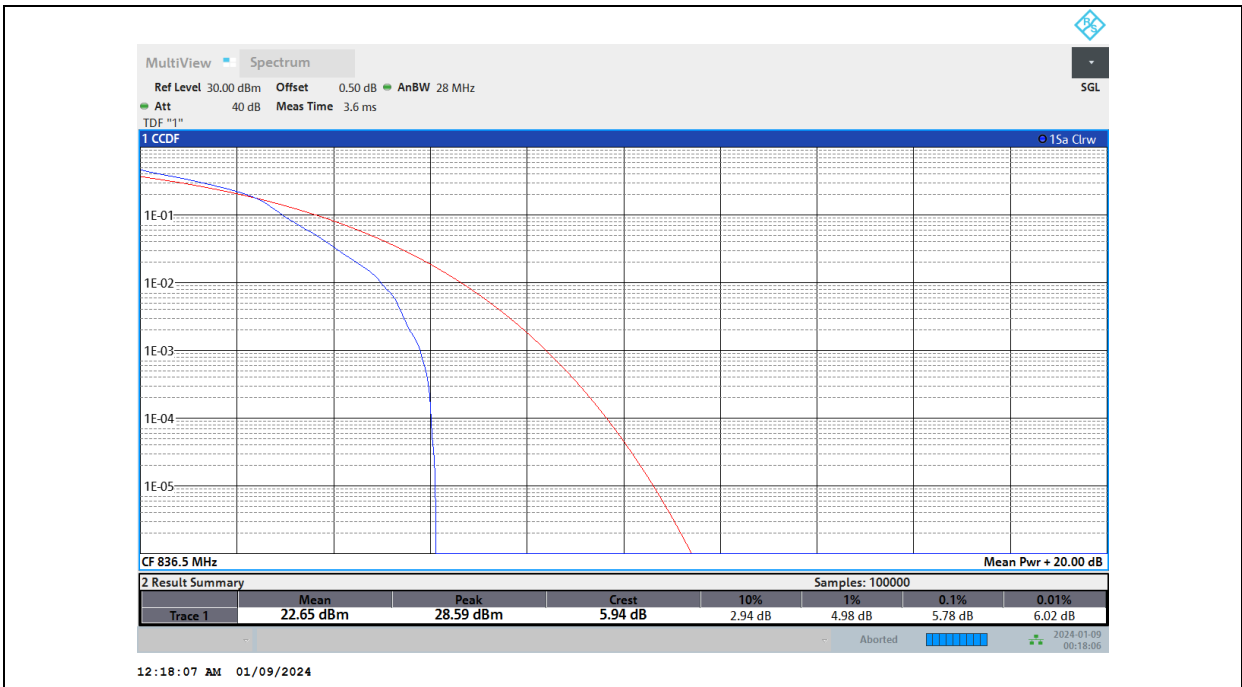

Band12-10MHz-16QAM-23095-50RB#0

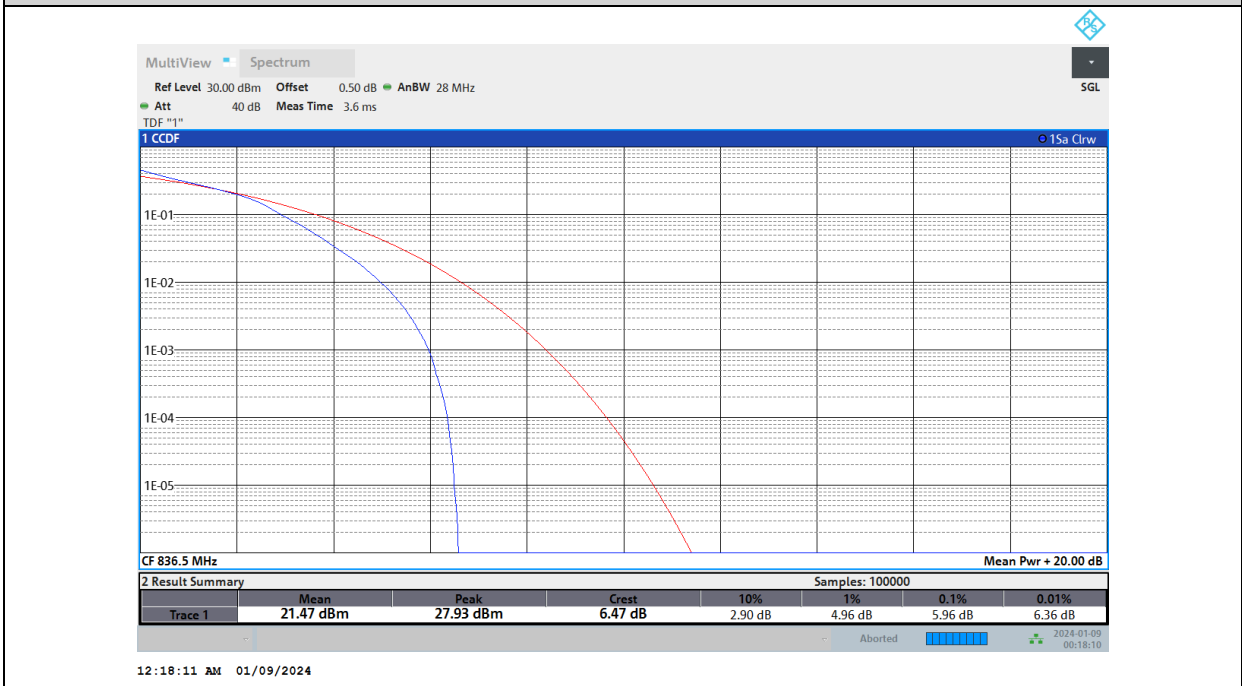

Band12-10MHz-64QAM-23095-1RB#0



BUREAU VERITAS

Test Report No.: PSU-NQN2311090109RF03

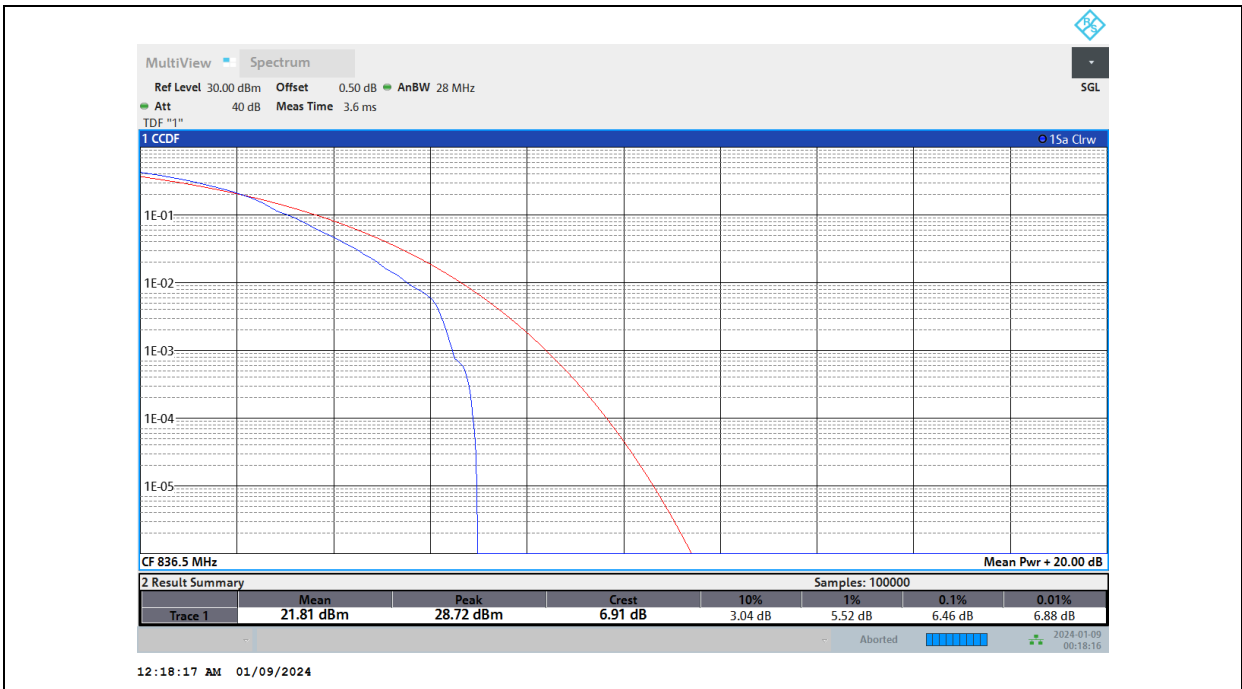

Band12-10MHz-64QAM-23095-50RB#0

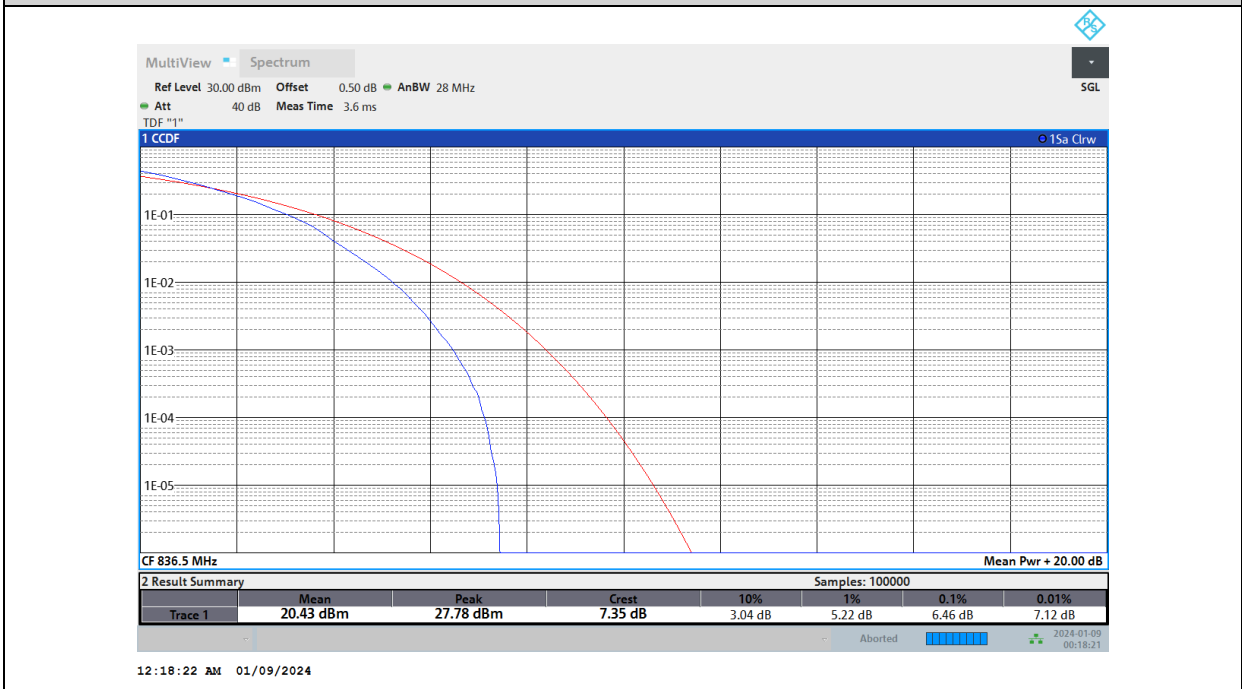

Band12-10MHz-QPSK-23130-1RB#0



BUREAU VERITAS

Test Report No.: PSU-NQN2311090109RF03

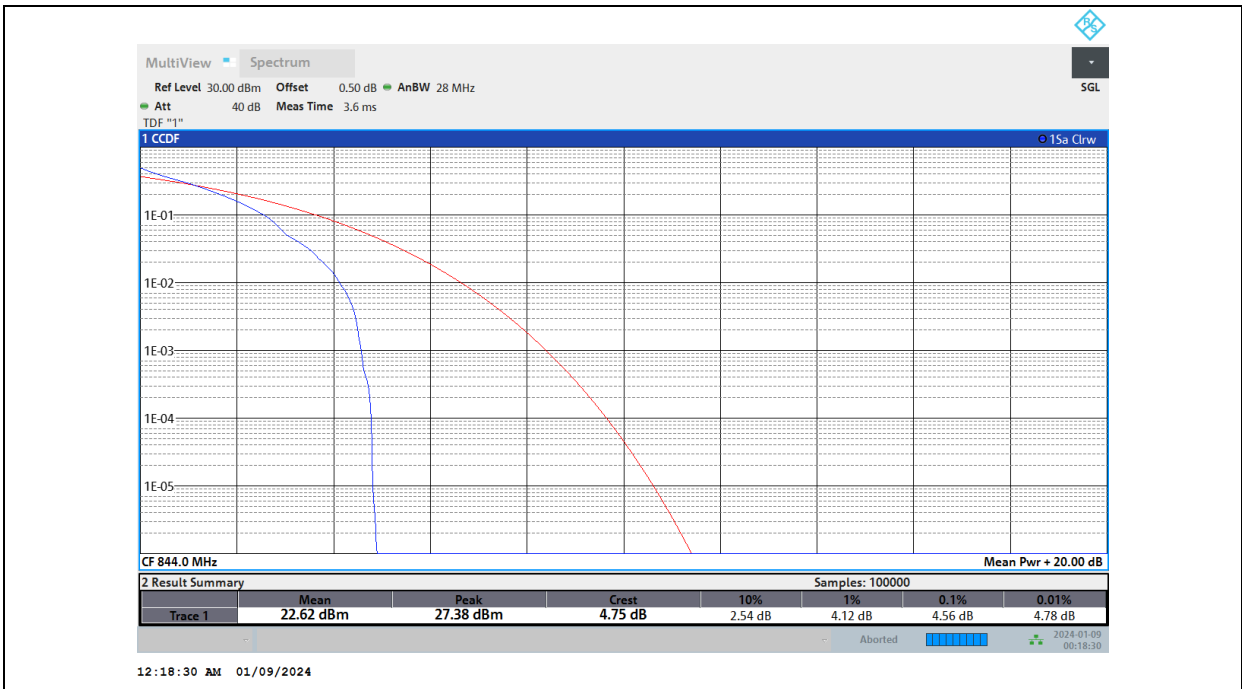

Band12-10MHz-QPSK-23130-50RB#0

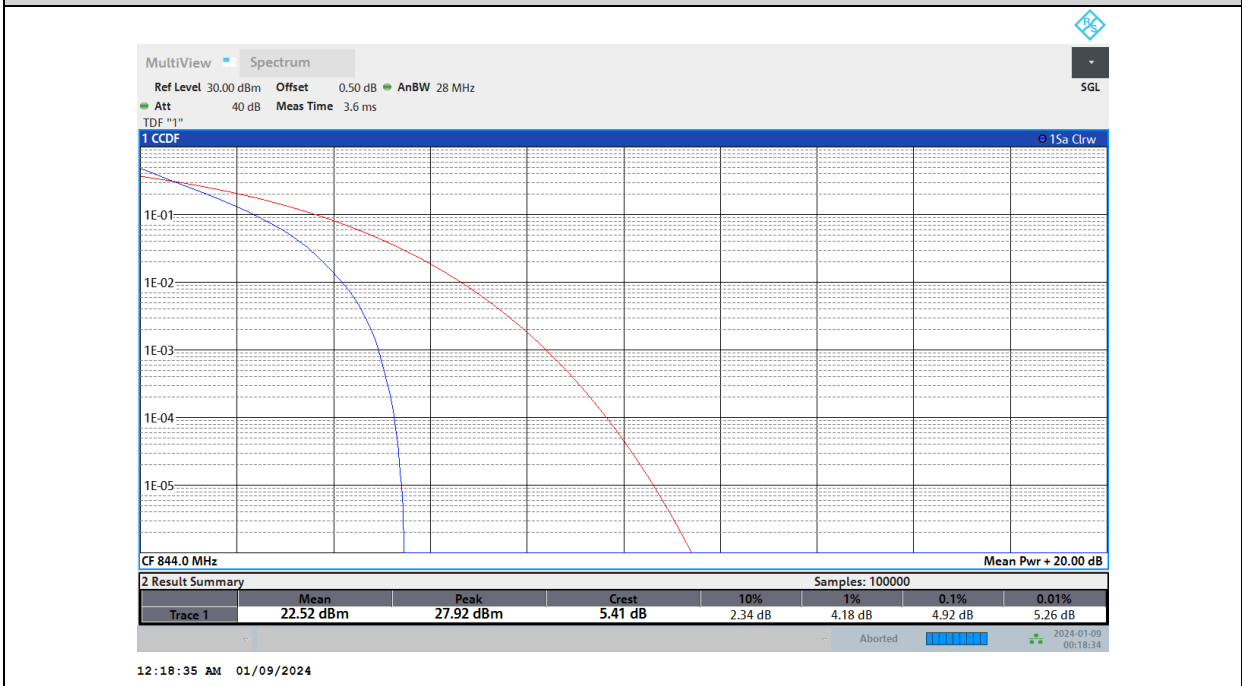

Band12-10MHz-16QAM-23130-1RB#0



BUREAU VERITAS

Test Report No.: PSU-NQN2311090109RF03

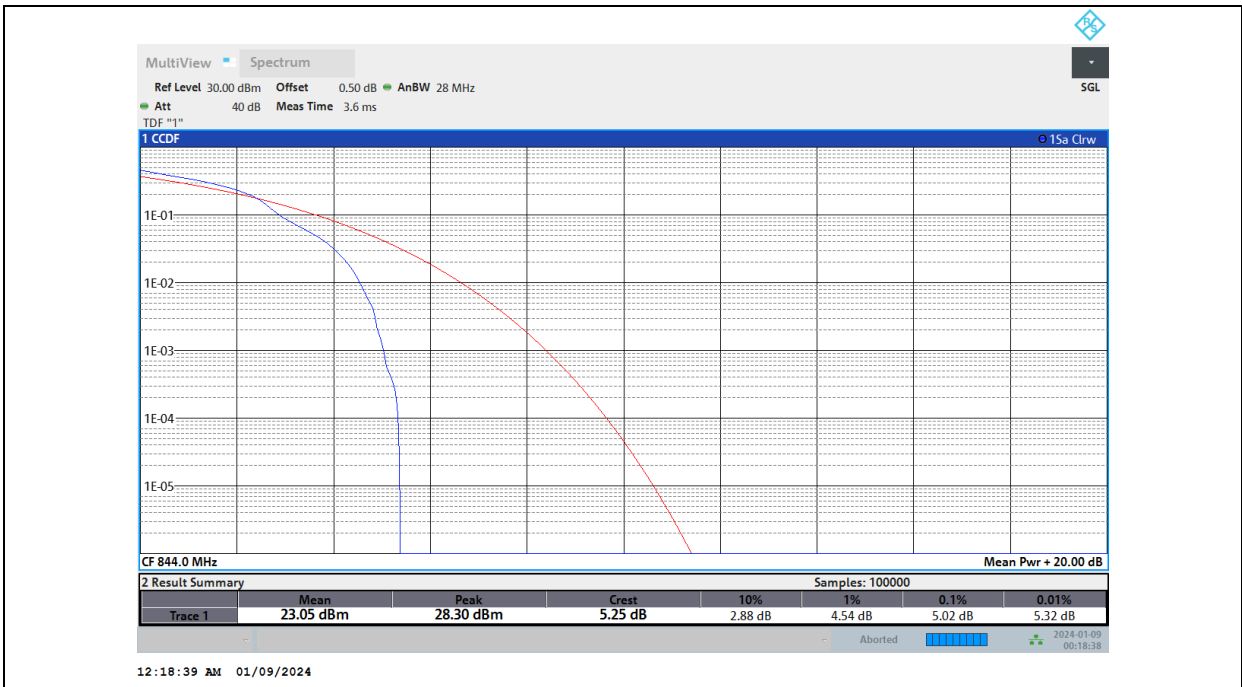

Band12-10MHz-16QAM-23130-50RB#0

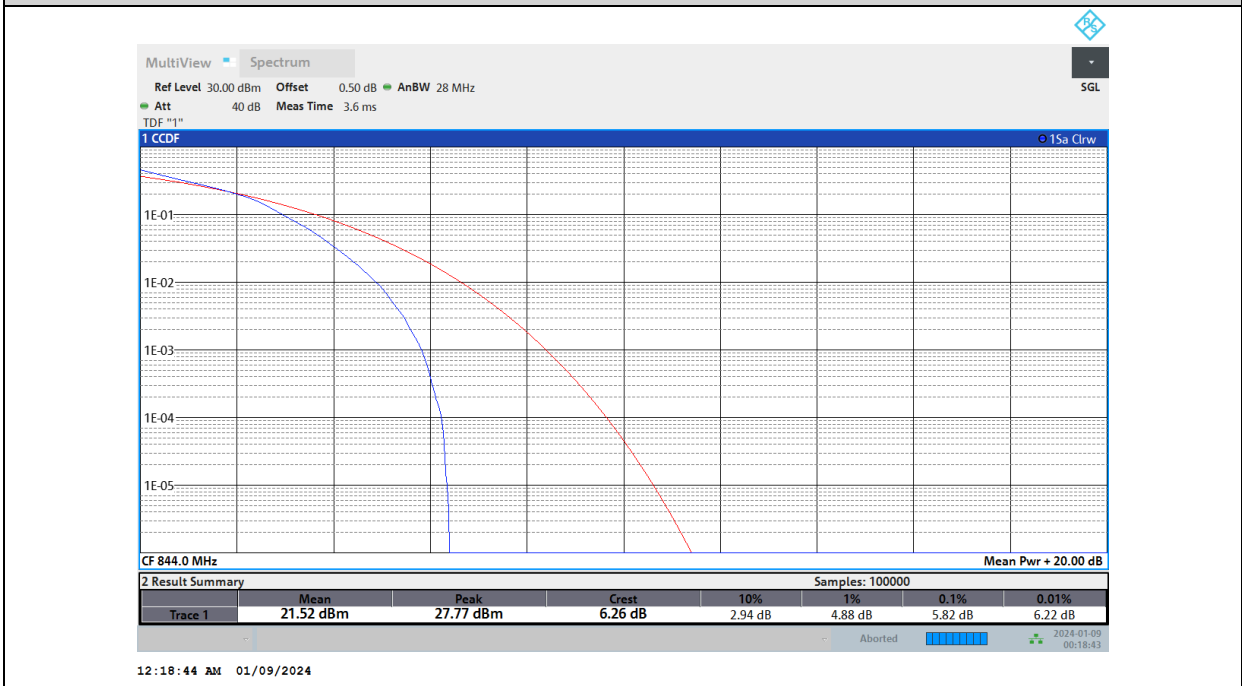

Band12-10MHz-64QAM-23130-1RB#0



BUREAU VERITAS

Test Report No.: PSU-NQN2311090109RF03

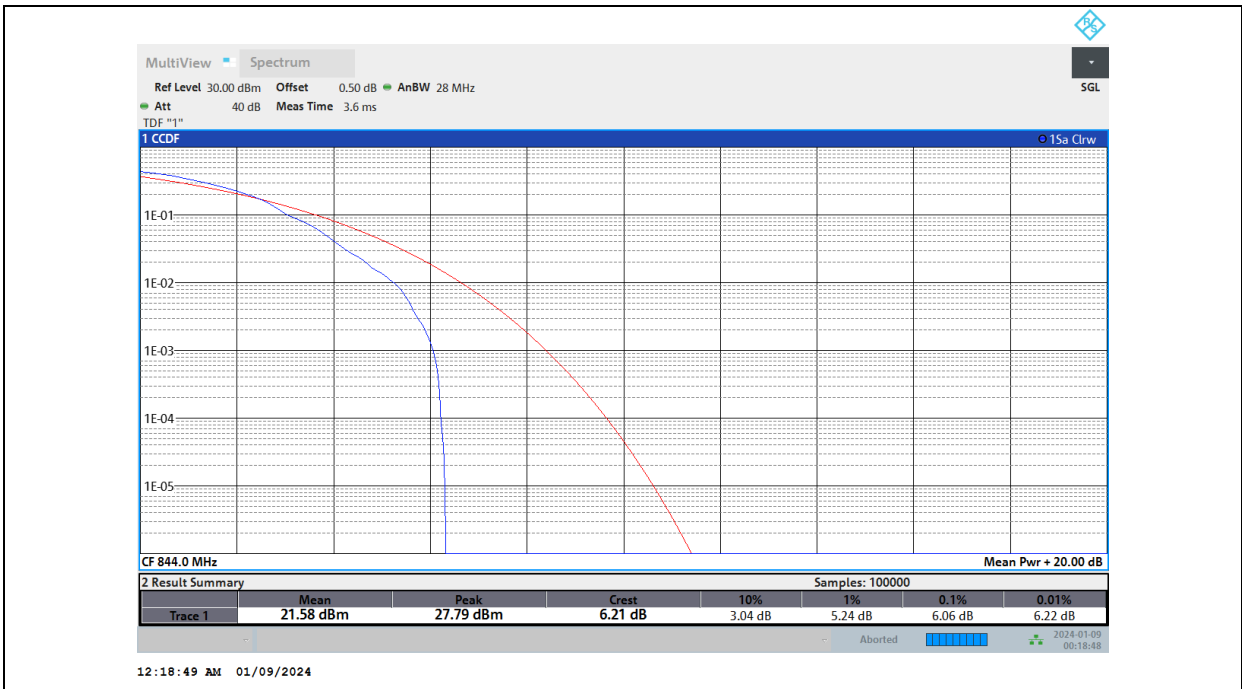

Band12-10MHz-64QAM-23130-50RB#0

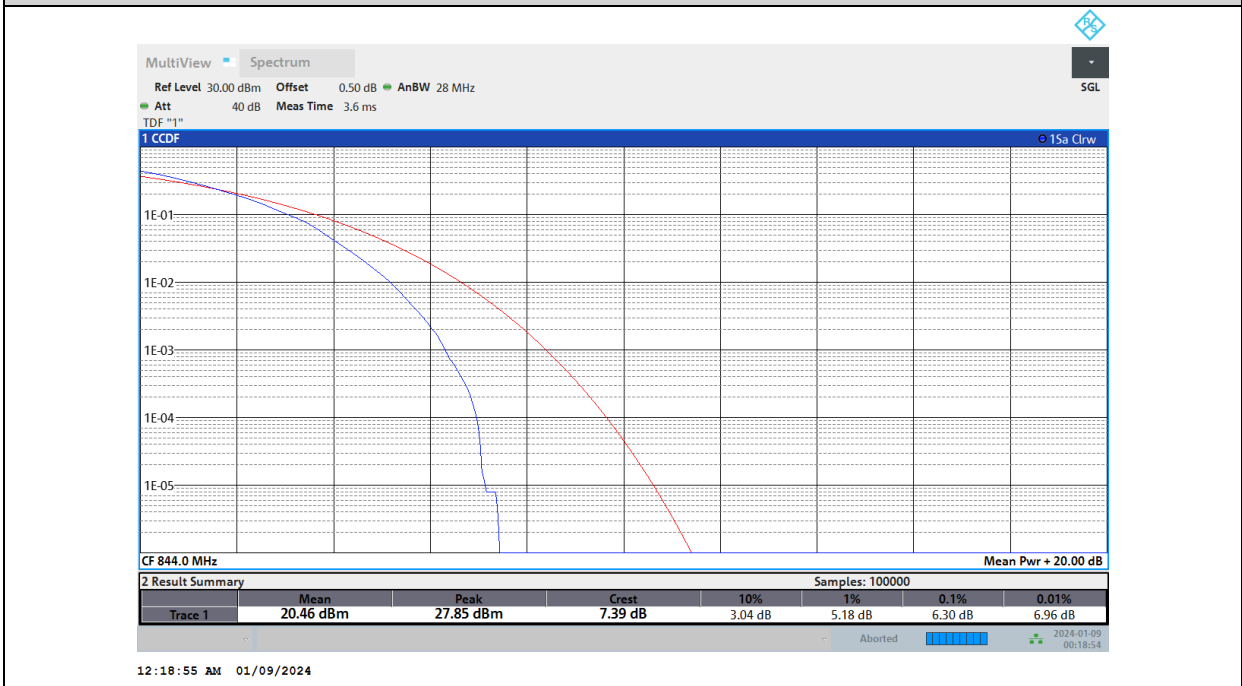



26DB BANDWIDTH AND OCCUPIED BANDWIDTH

Test Result

Band	Bandwidth	Modulation	Channel	RB Configuration	Occupied Bandwidth (MHz)	26dB Bandwidth (MHz)	Verdict
Band12	1.4MHz	QPSK	23017	6RB#0	1.090	1.30	PASS
Band12	1.4MHz	16QAM	23017	6RB#0	1.088	1.28	PASS
Band12	1.4MHz	64QAM	23017	6RB#0	1.094	1.29	PASS
Band12	1.4MHz	QPSK	23095	6RB#0	1.093	1.27	PASS
Band12	1.4MHz	16QAM	23095	6RB#0	1.088	1.26	PASS
Band12	1.4MHz	64QAM	23095	6RB#0	1.085	1.27	PASS
Band12	1.4MHz	QPSK	23173	6RB#0	1.085	1.27	PASS
Band12	1.4MHz	16QAM	23173	6RB#0	1.091	1.29	PASS
Band12	1.4MHz	64QAM	23173	6RB#0	1.084	1.26	PASS
Band12	3MHz	QPSK	23025	15RB#0	2.693	2.93	PASS
Band12	3MHz	16QAM	23025	15RB#0	2.690	2.96	PASS
Band12	3MHz	64QAM	23025	15RB#0	2.689	2.95	PASS
Band12	3MHz	QPSK	23095	15RB#0	2.693	2.93	PASS
Band12	3MHz	16QAM	23095	15RB#0	2.687	2.96	PASS
Band12	3MHz	64QAM	23095	15RB#0	2.685	2.94	PASS
Band12	3MHz	QPSK	23165	15RB#0	2.689	2.93	PASS
Band12	3MHz	16QAM	23165	15RB#0	2.685	2.96	PASS
Band12	3MHz	64QAM	23165	15RB#0	2.690	2.94	PASS
Band12	5MHz	QPSK	23035	25RB#0	4.492	4.92	PASS
Band12	5MHz	16QAM	23035	25RB#0	4.478	4.86	PASS
Band12	5MHz	64QAM	23035	25RB#0	4.472	4.92	PASS
Band12	5MHz	QPSK	23095	25RB#0	4.485	4.93	PASS
Band12	5MHz	16QAM	23095	25RB#0	4.492	4.88	PASS
Band12	5MHz	64QAM	23095	25RB#0	4.485	4.92	PASS
Band12	5MHz	QPSK	23155	25RB#0	4.474	4.93	PASS
Band12	5MHz	16QAM	23155	25RB#0	4.484	4.86	PASS
Band12	5MHz	64QAM	23155	25RB#0	4.470	4.88	PASS
Band12	10MHz	QPSK	23060	50RB#0	8.965	9.77	PASS
Band12	10MHz	16QAM	23060	50RB#0	8.954	9.65	PASS
Band12	10MHz	64QAM	23060	50RB#0	8.953	9.68	PASS
Band12	10MHz	QPSK	23095	50RB#0	9.943	9.74	PASS
Band12	10MHz	16QAM	23095	50RB#0	8.955	9.65	PASS
Band12	10MHz	64QAM	23095	50RB#0	8.950	9.68	PASS
Band12	10MHz	QPSK	23130	50RB#0	8.940	9.74	PASS
Band12	10MHz	16QAM	23130	50RB#0	8.939	9.71	PASS
Band12	10MHz	64QAM	23130	50RB#0	8.933	9.65	PASS



Test Graphs

Occupied Bandwidth

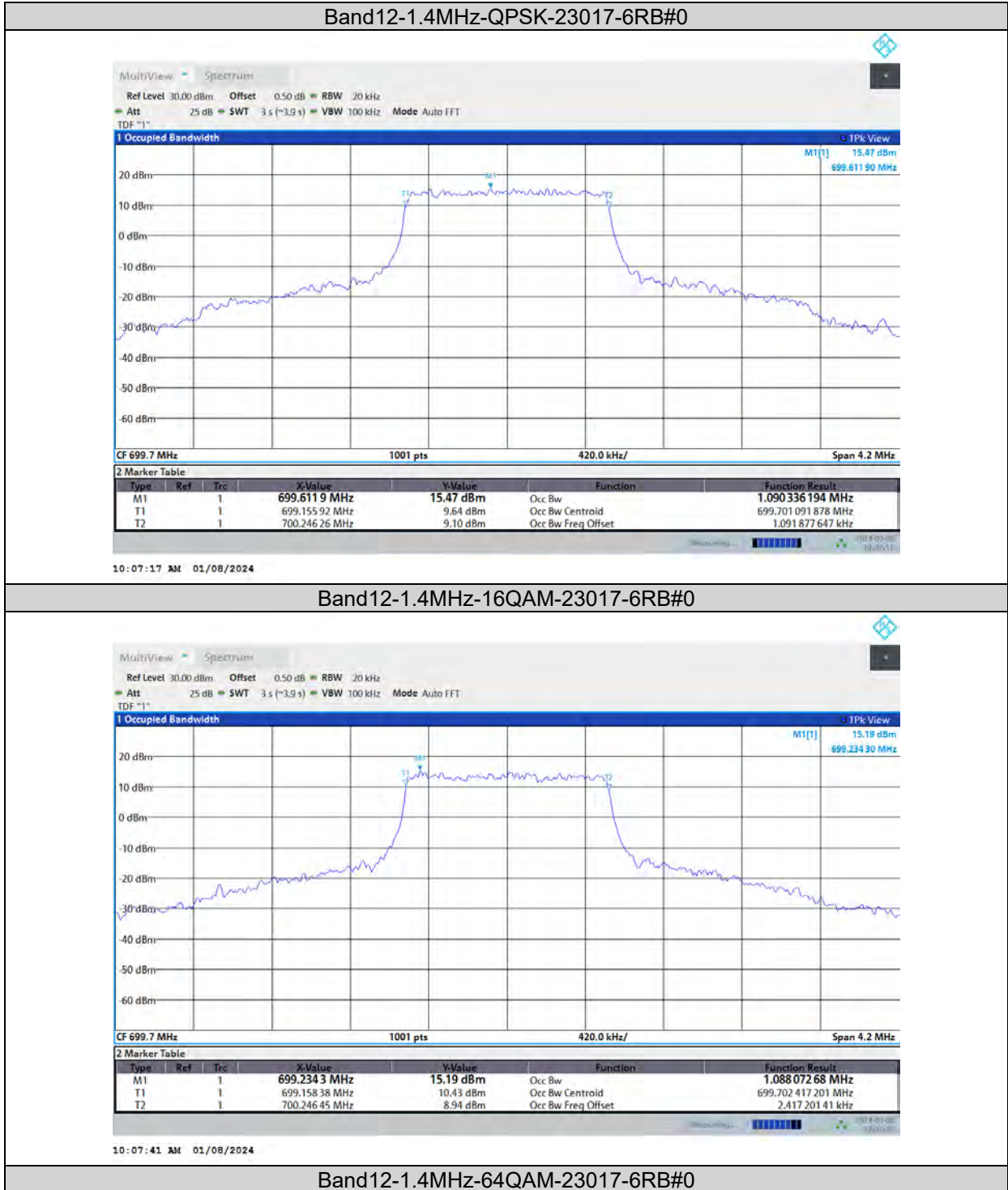



**BUREAU
VERITAS**

Test Report No.: PSU-NQN2311090109RF03

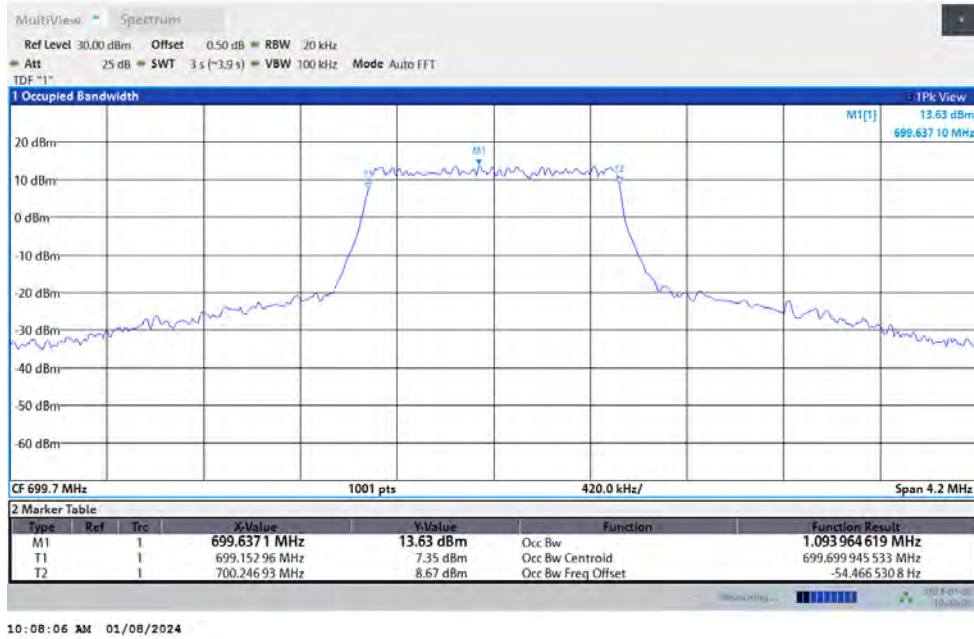

10:08:06 AM 01/08/2024

Band12-1.4MHz-QPSK-23095-6RB#0

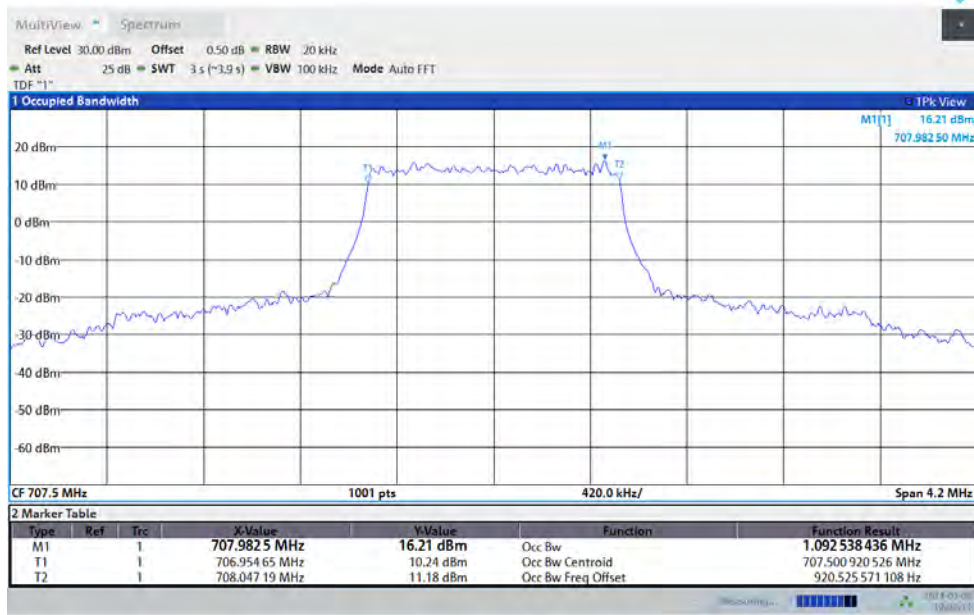

10:08:34 AM 01/08/2024

Band12-1.4MHz-16QAM-23095-6RB#0



BUREAU VERITAS

Test Report No.: PSU-NQN2311090109RF03



Band12-1.4MHz-64QAM-23095-6RB#0

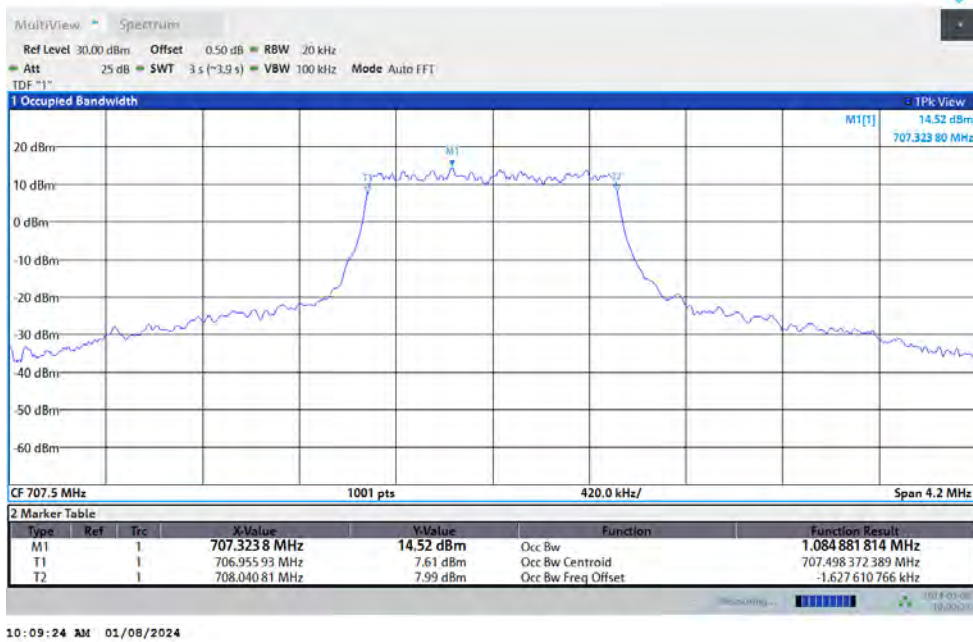

Band12-1.4MHz-QPSK-23173-6RB#0



BUREAU VERITAS

Test Report No.: PSU-NQN2311090109RF03

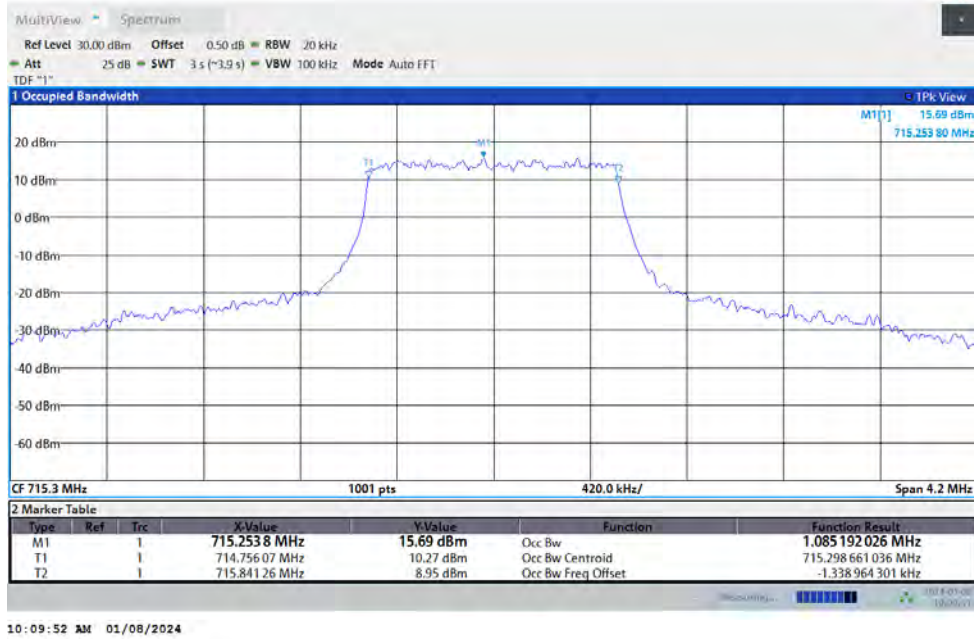

10:09:52 AM 01/08/2024

Band12-1.4MHz-16QAM-23173-6RB#0

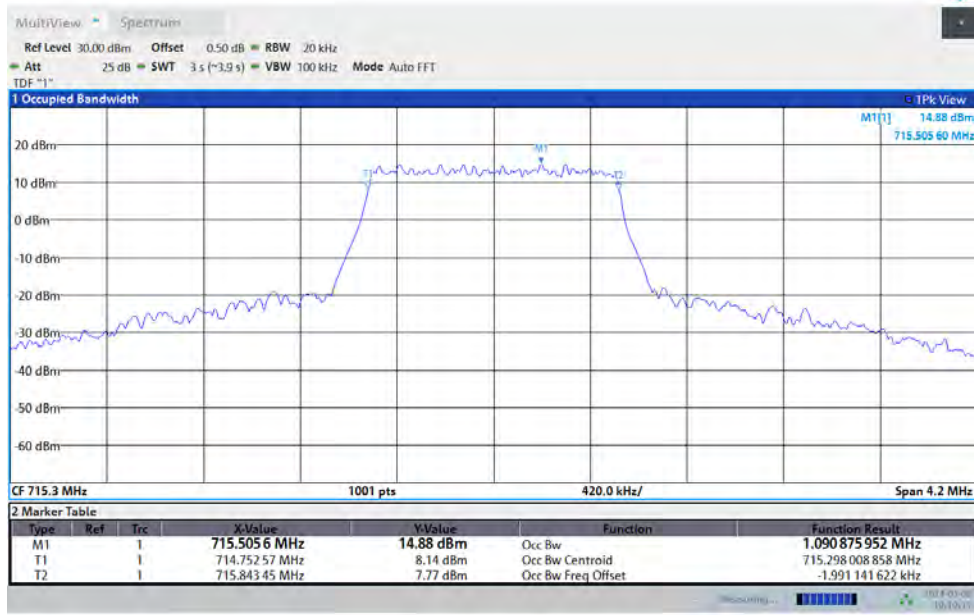

10:10:16 AM 01/08/2024

Band12-1.4MHz-64QAM-23173-6RB#0



BUREAU VERITAS

Test Report No.: PSU-NQN2311090109RF03

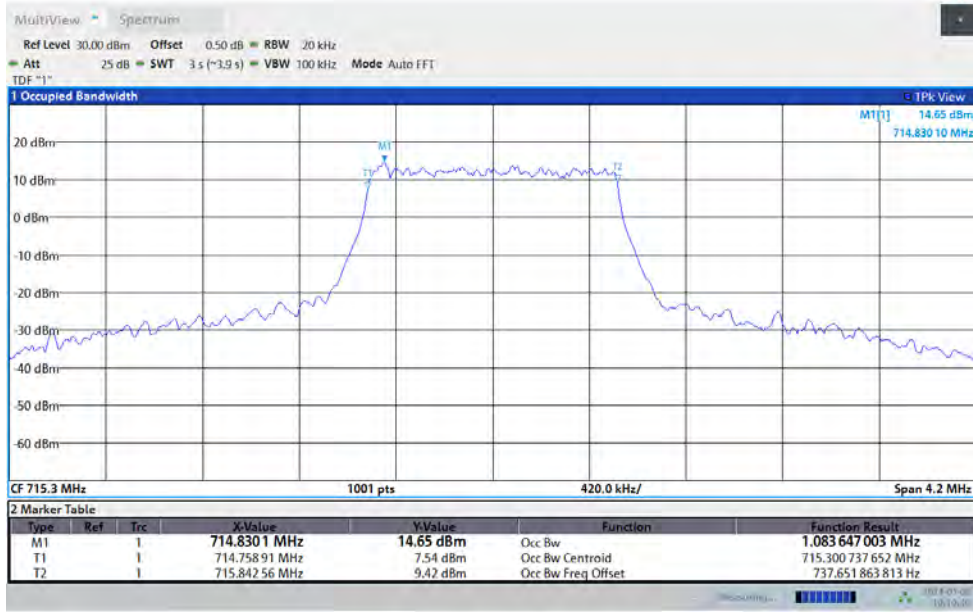

10:10:42 AM 01/08/2024

Band12-3MHz-QPSK-23025-15RB#0

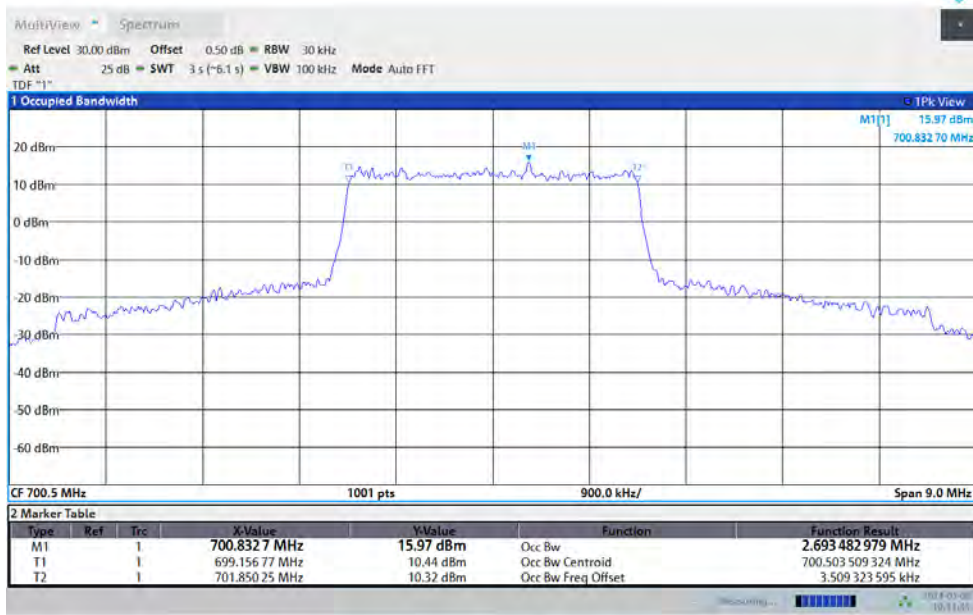

10:11:45 AM 01/08/2024

Band12-3MHz-16QAM-23025-15RB#0



BUREAU VERITAS

Test Report No.: PSU-NQN2311090109RF03

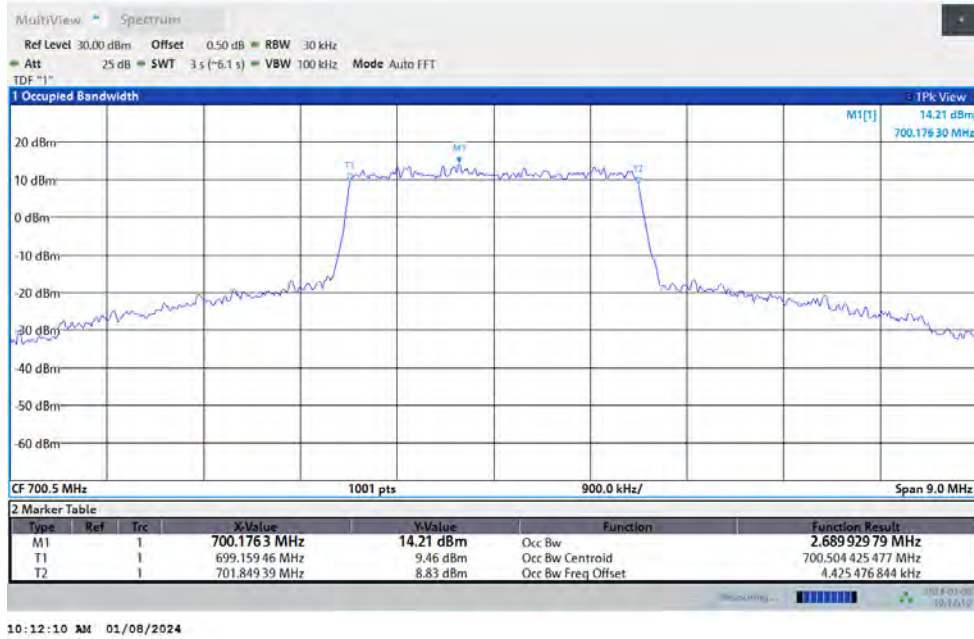

Band12-3MHz-64QAM-23025-15RB#0

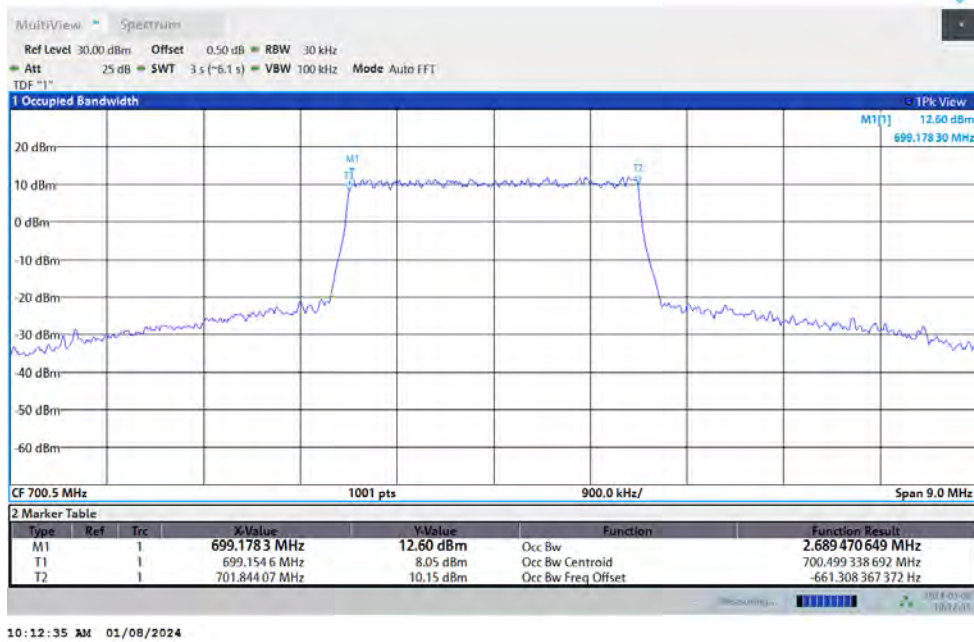

Band12-3MHz-QPSK-23095-6RB#0



BUREAU VERITAS

Test Report No.: PSU-NQN2311090109RF03

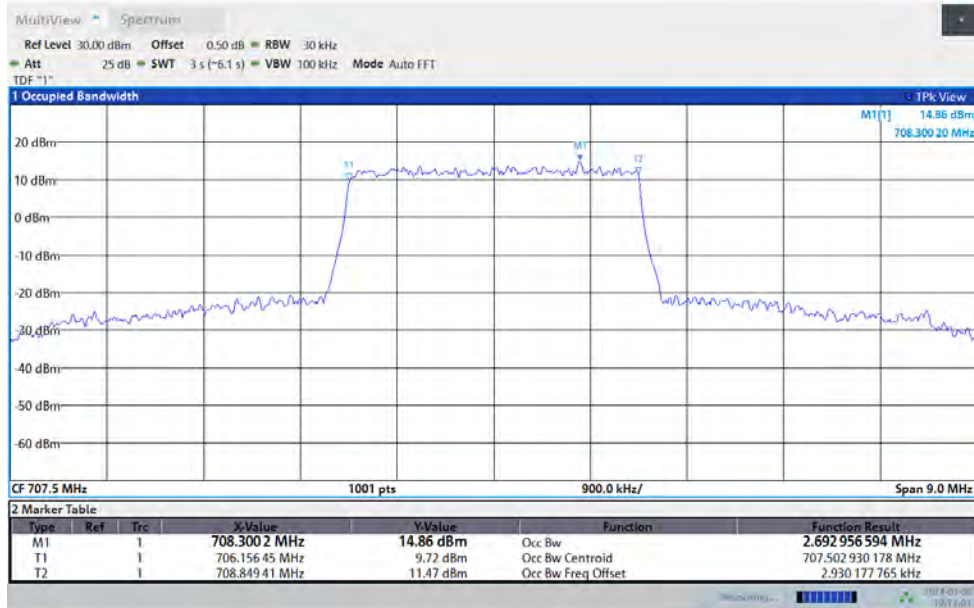

10:13:03 AM 01/08/2024

Band12-3MHz-16QAM-23095-6RB#0

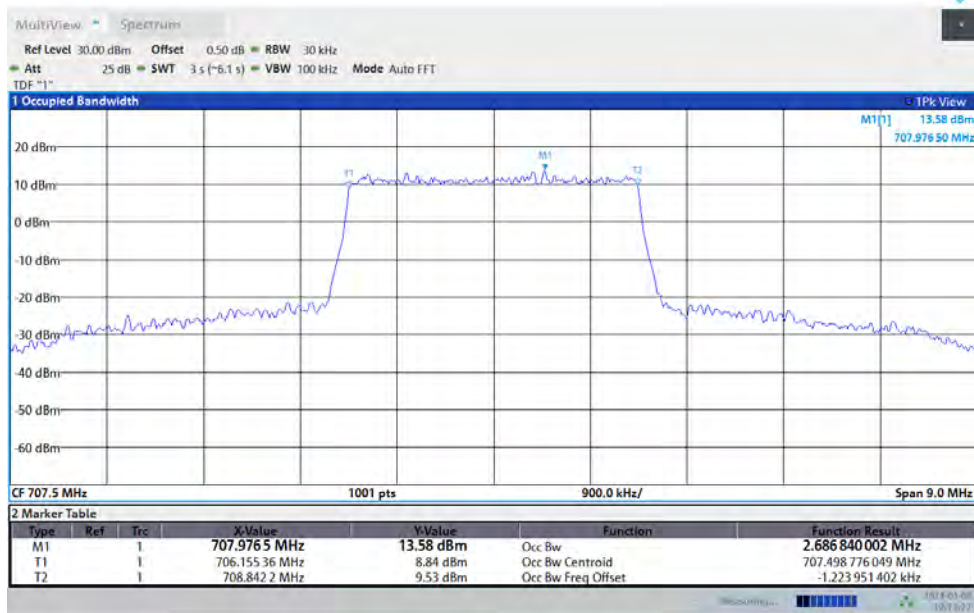

10:13:28 AM 01/08/2024

Band12-3MHz-64QAM-23095-6RB#0



BUREAU VERITAS

Test Report No.: PSU-NQN2311090109RF03

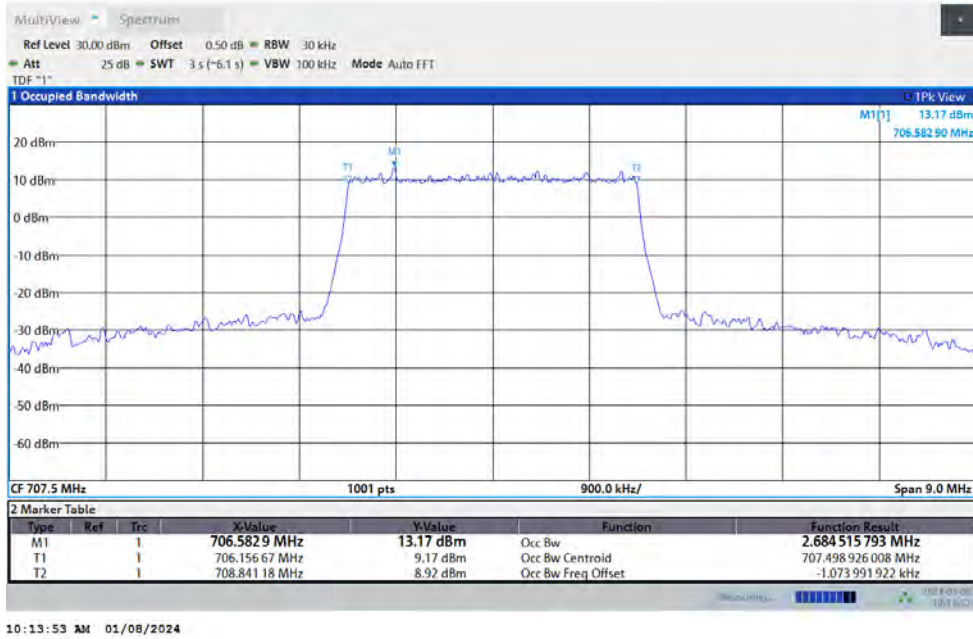

Band12-3MHz-QPSK-23165-15RB#0

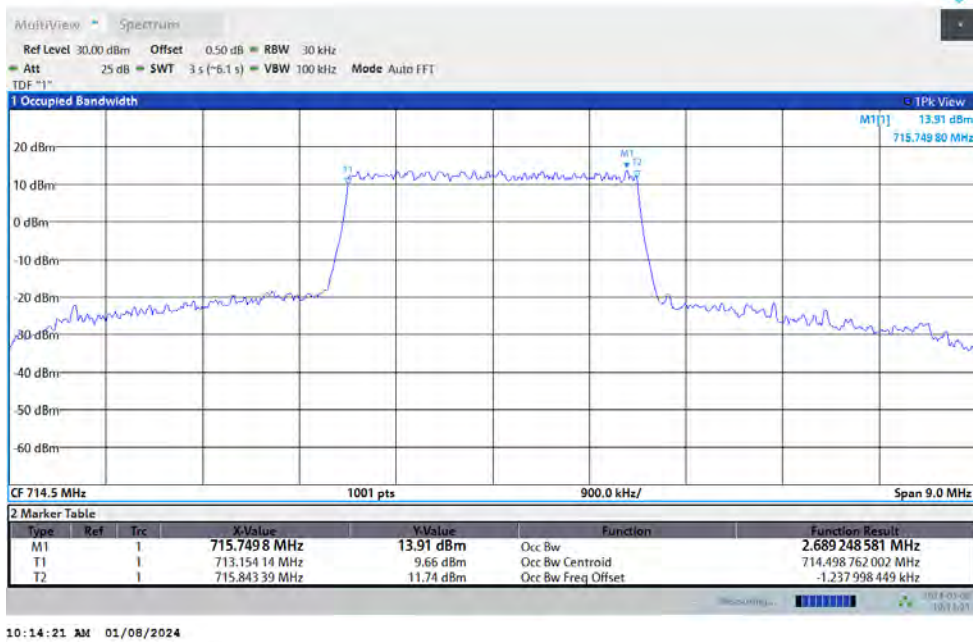

Band12-3MHz-16QAM-23165-15RB#0



BUREAU VERITAS

Test Report No.: PSU-NQN2311090109RF03



10:14:45 AM 01/08/2024

Band12-3MHz-64QAM-23165-15RB#0



10:15:10 AM 01/08/2024

Band12-5MHz-QPSK-23035-25RB#0



BUREAU VERITAS

Test Report No.: PSU-NQN2311090109RF03

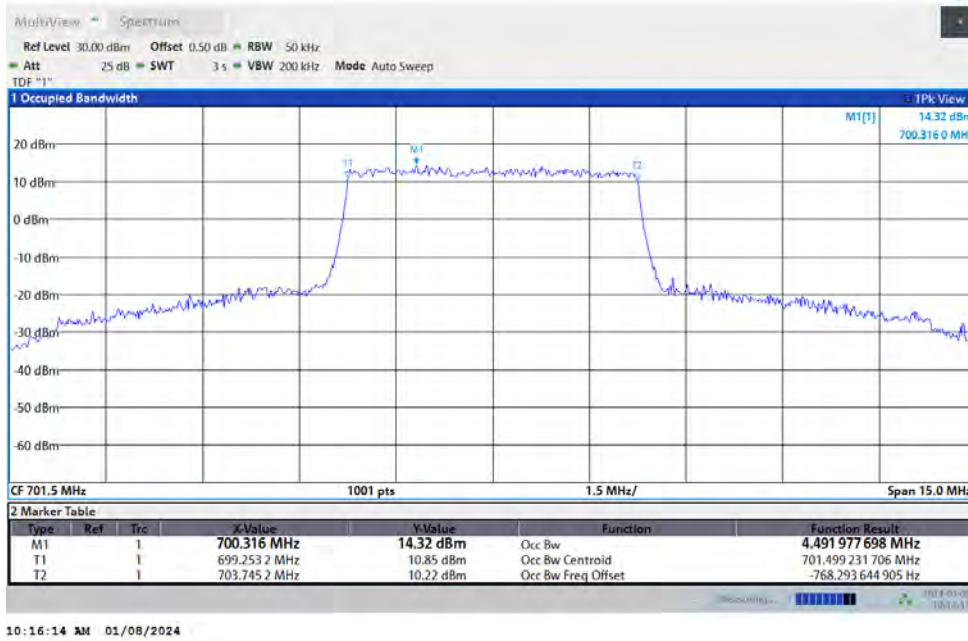

10:16:14 AM 01/08/2024

Band12-5MHz-16QAM-23035-25RB#0

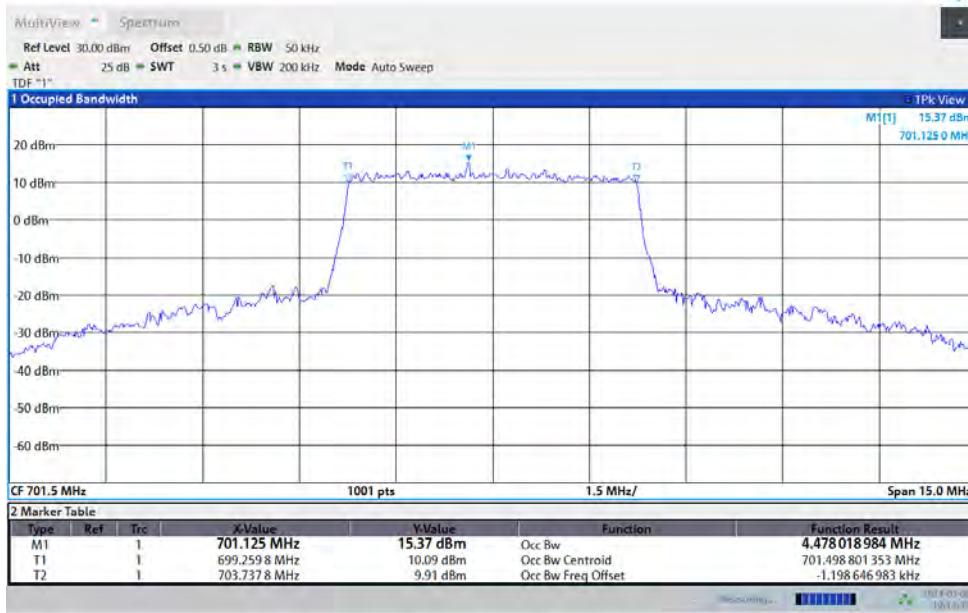

10:16:38 AM 01/08/2024

Band12-5MHz-64QAM-23035-25RB#0



**BUREAU
VERITAS**

Test Report No.: PSU-NQN2311090109RF03

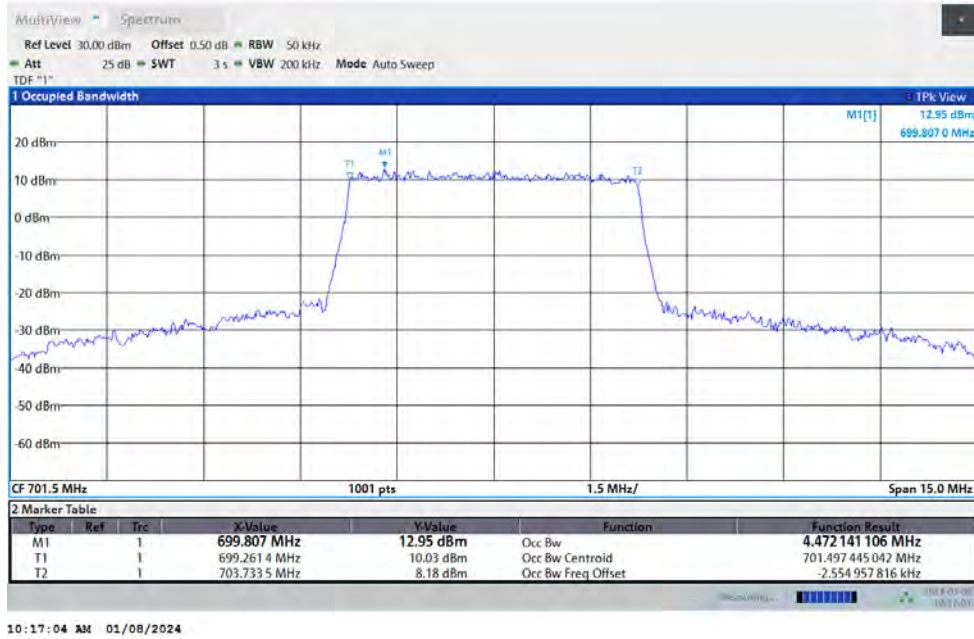

10:17:04 AM 01/08/2024

Band12-5MHz-QPSK-23095-25RB#0

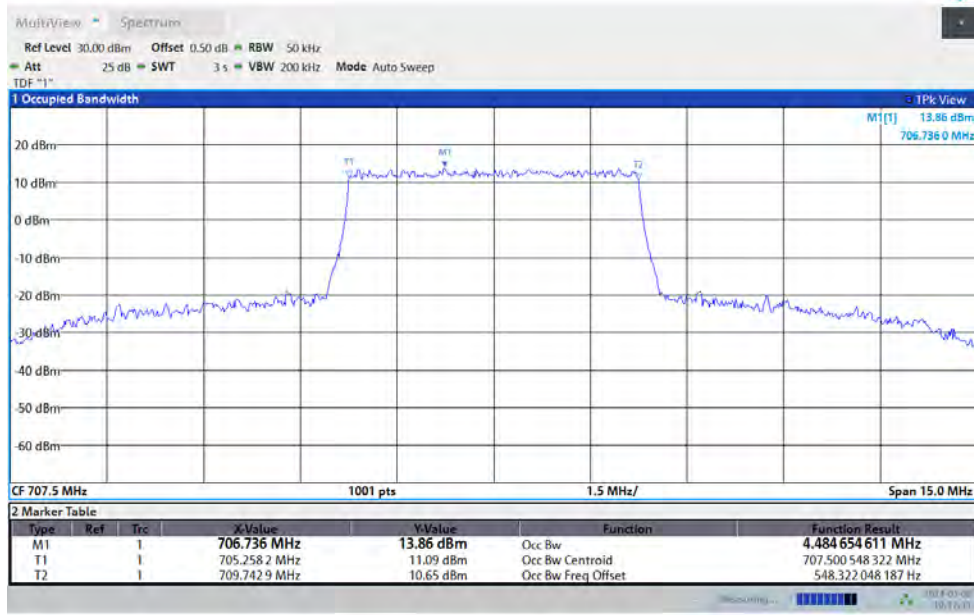

10:17:32 AM 01/08/2024

Band12-5MHz-16QAM-23095-6RB#0



BUREAU VERITAS

Test Report No.: PSU-NQN2311090109RF03

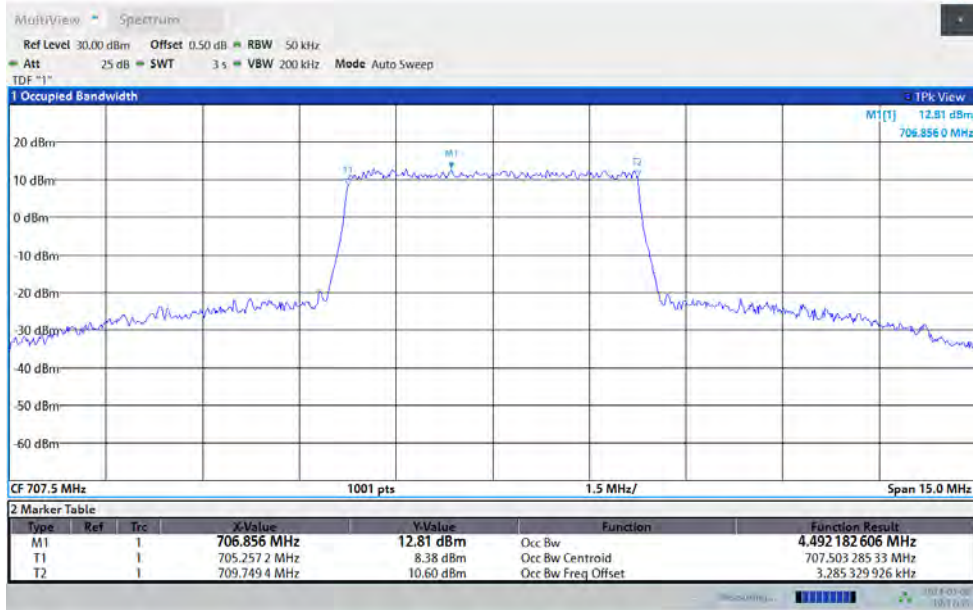

10:17:56 AM 01/08/2024

Band12-5MHz-64QAM-23095-6RB#0

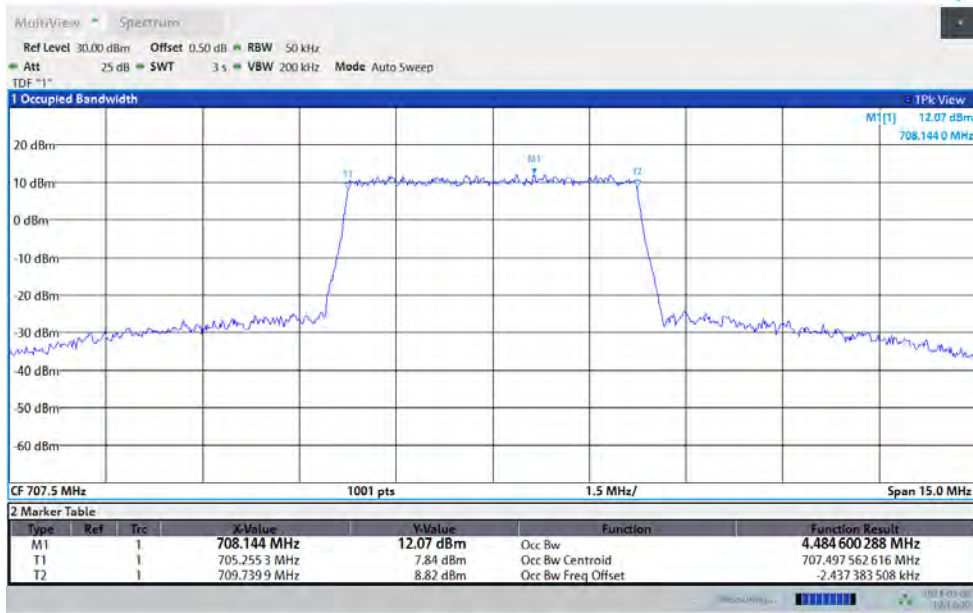

10:18:21 AM 01/08/2024

Band12-5MHz-QPSK-23155-25RB#0



BUREAU VERITAS

Test Report No.: PSU-NQN2311090109RF03

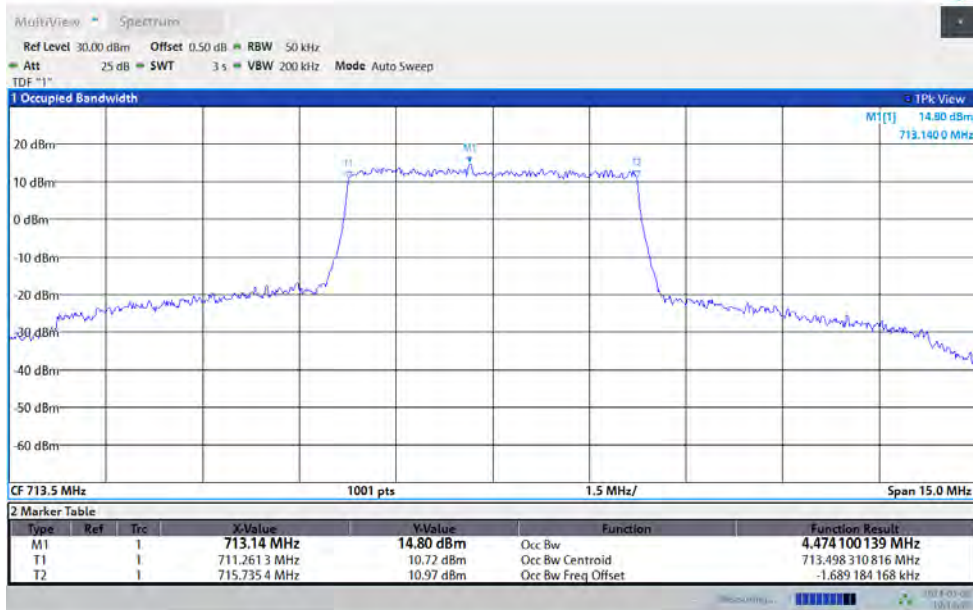

Band12-5MHz-16QAM-23155-25RB#0

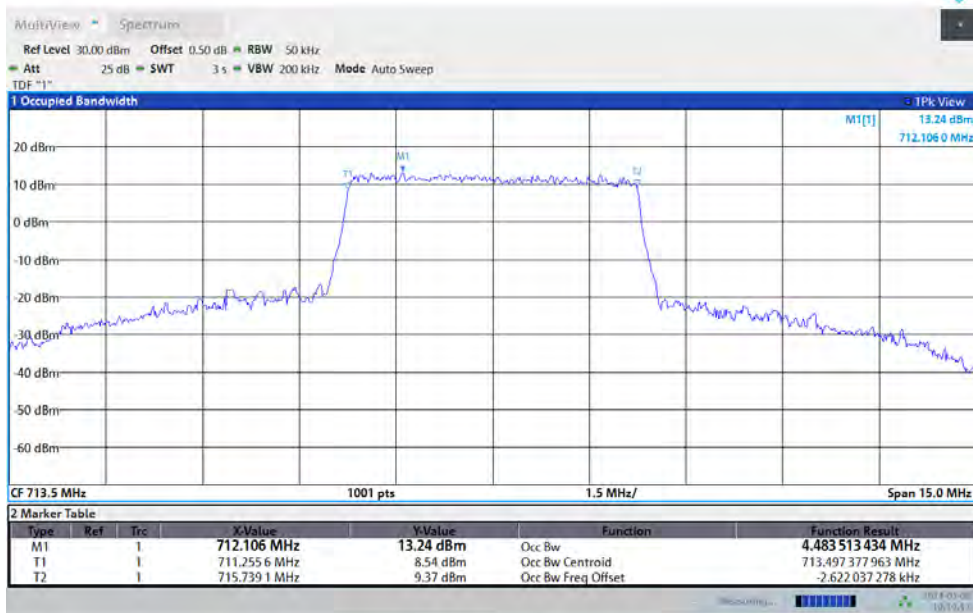

Band12-5MHz-64QAM-23155-25RB#0



**BUREAU
VERITAS**

Test Report No.: PSU-NQN2311090109RF03

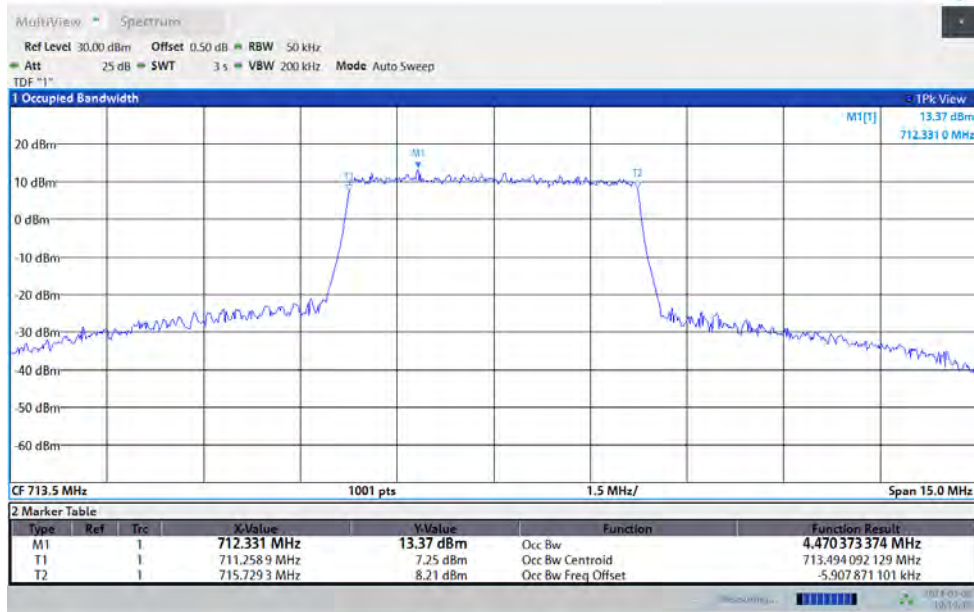

10:19:39 AM 01/08/2024

Band12-10MHz-QPSK-23060-50RB#0

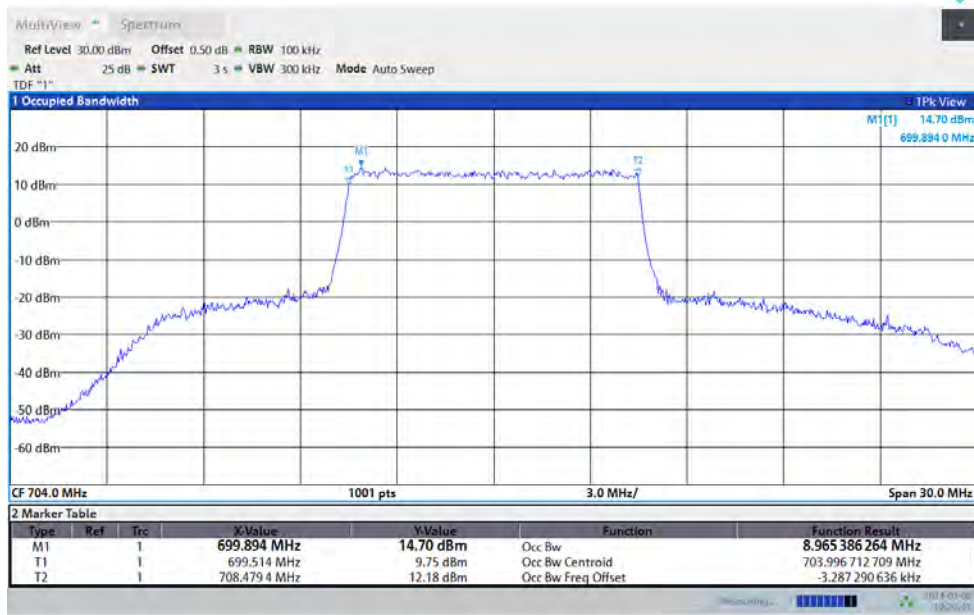

10:20:42 AM 01/08/2024

Band12-10MHz-16QAM-23060-50RB#0



BUREAU VERITAS

Test Report No.: PSU-NQN2311090109RF03

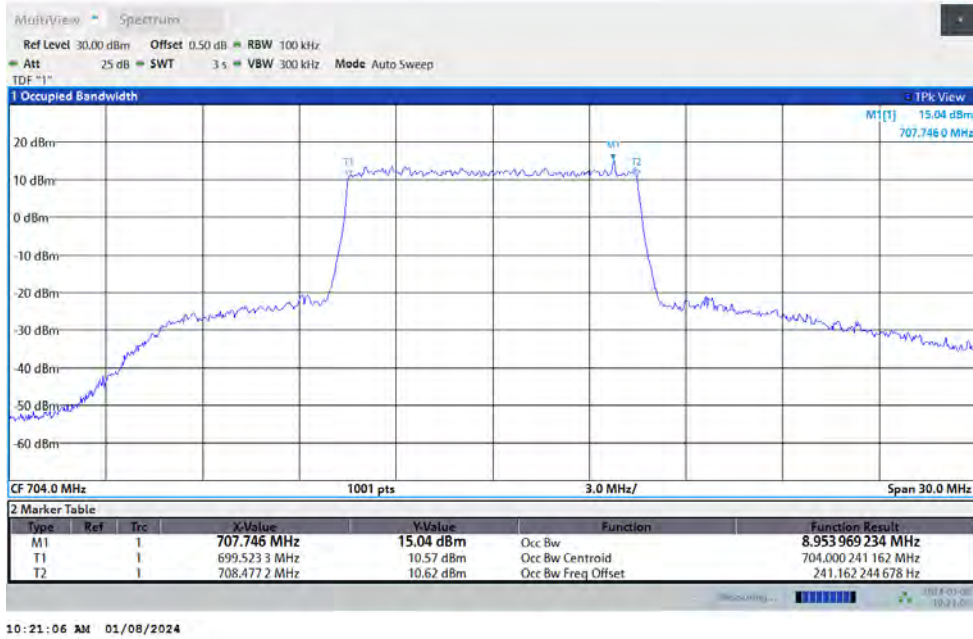

10:21:06 AM 01/08/2024

Band12-10MHz-64QAM-23060-50RB#0

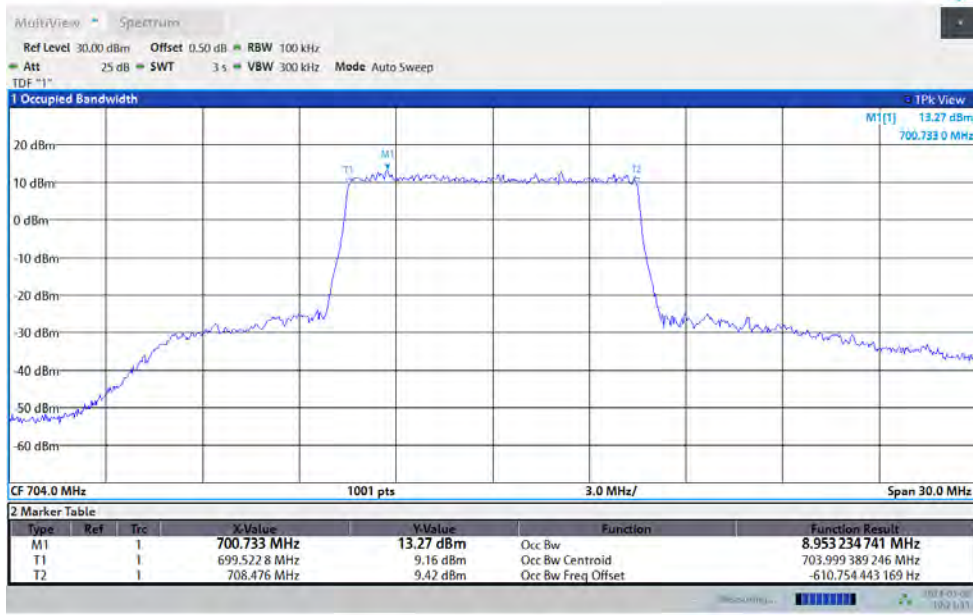

10:21:32 AM 01/08/2024

Band12-10MHz-QPSK-23095-50RB#0



BUREAU VERITAS

Test Report No.: PSU-NQN2311090109RF03

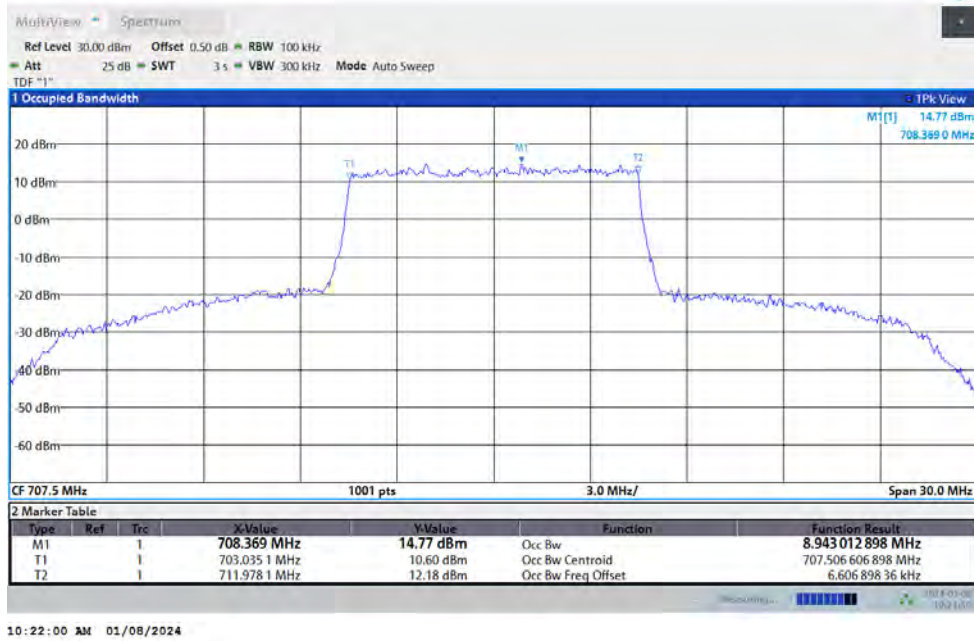

Band12-10MHz-16QAM-23095-50RB#0

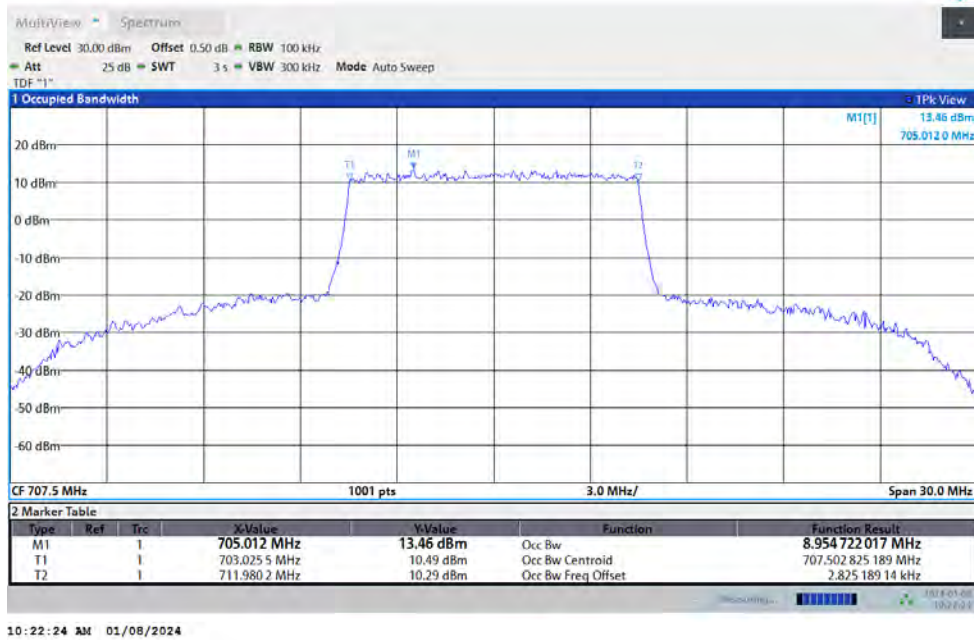

Band12-10MHz-64QAM-23095-50RB#0



BUREAU VERITAS

Test Report No.: PSU-NQN2311090109RF03

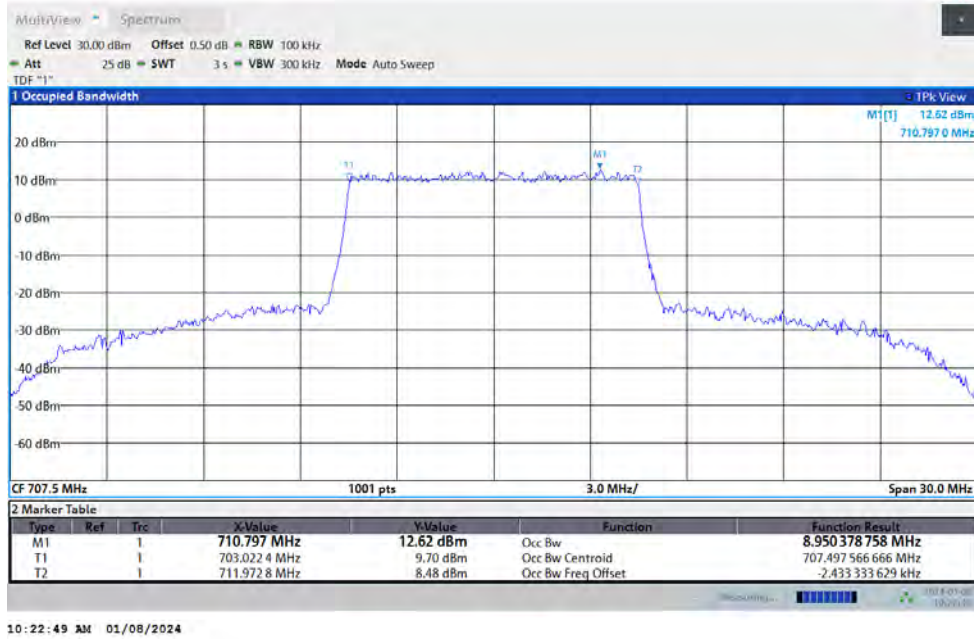

Band12-10MHz-QPSK-23130-50RB#0

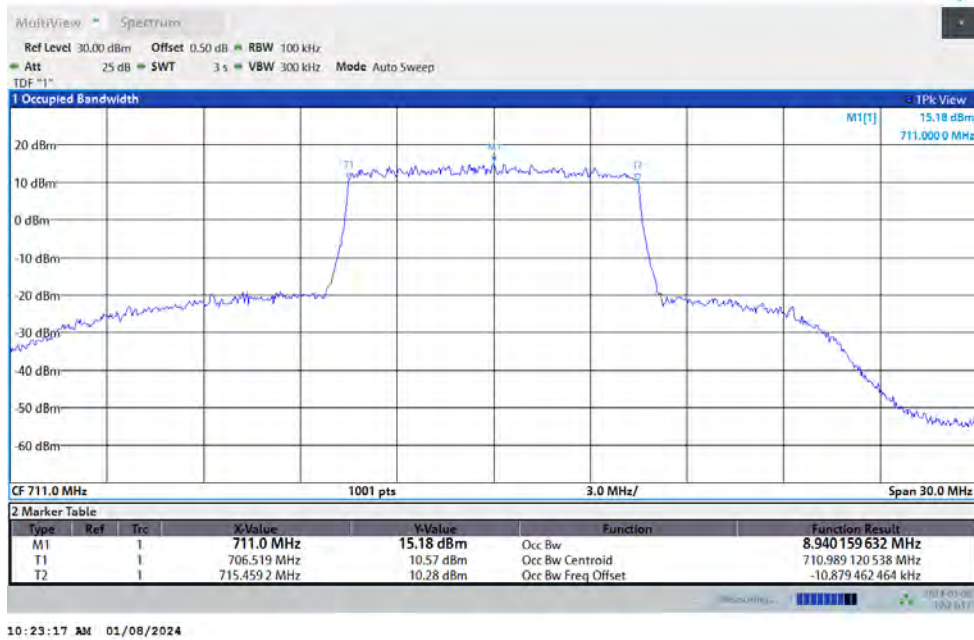

Band12-10MHz-16QAM-23130-50RB#0



BUREAU VERITAS

Test Report No.: PSU-NQN2311090109RF03

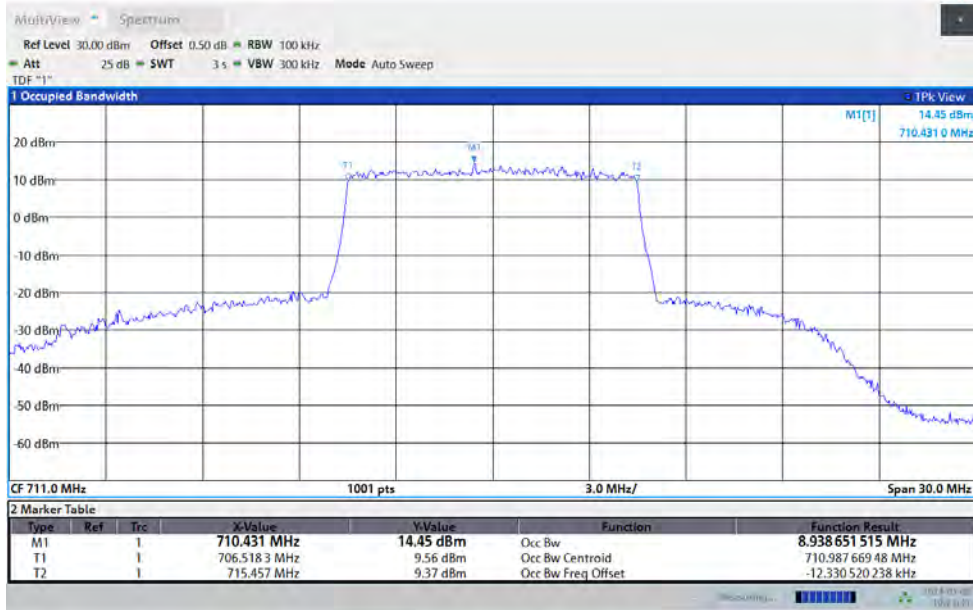

10:23:42 AM 01/08/2024

Band12-10MHz-64QAM-23130-50RB#0

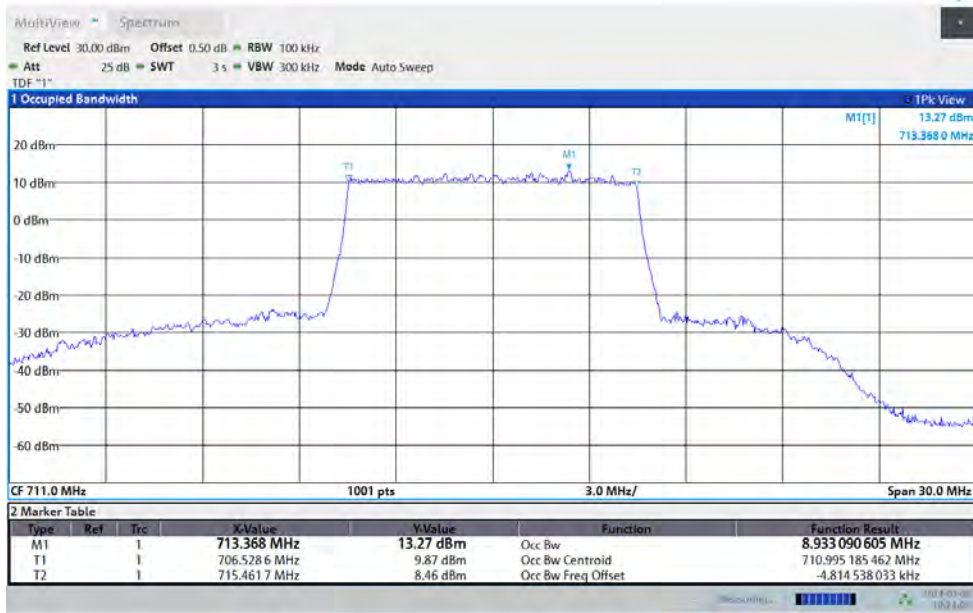

10:24:07 AM 01/08/2024



Test Report No.: PSU-NQN2311090109RF03

26dB Bandwidth

Band12-1.4MHz-QPSK-23017-6RB#0



Band12-1.4MHz-16QAM-23017-6RB#0



Band12-1.4MHz-64QAM-23017-6RB#0



BUREAU VERITAS

Test Report No.: PSU-NQN2311090109RF03

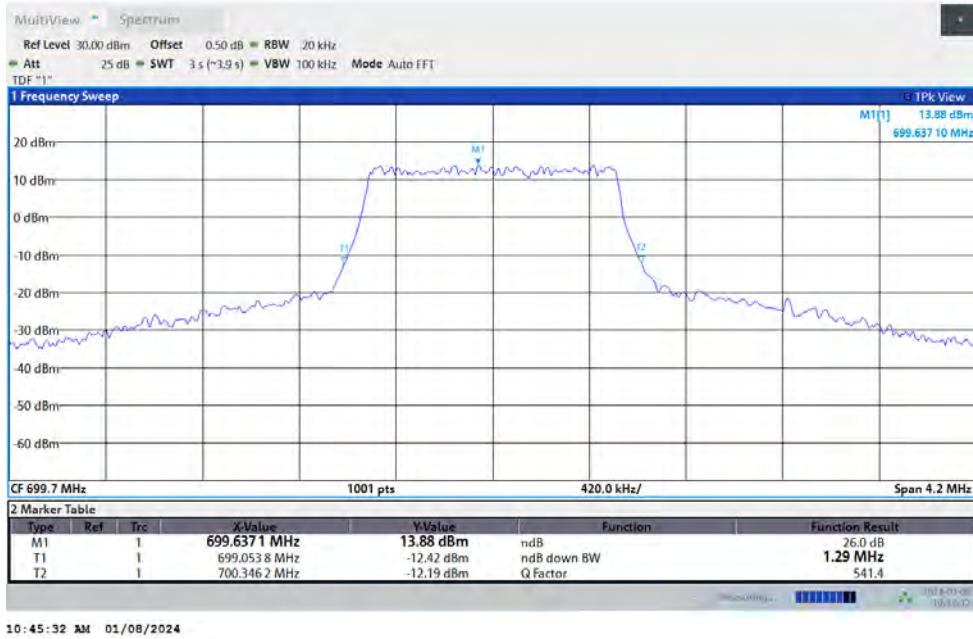

10:45:32 AM 01/08/2024

Band12-1.4MHz-QPSK-23095-6RB#0

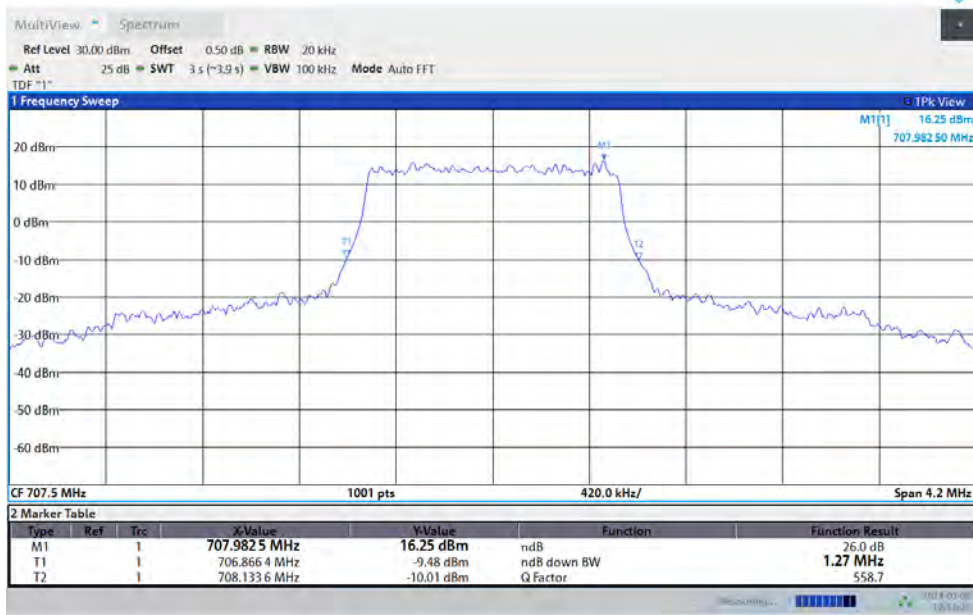

10:46:27 AM 01/08/2024

Band12-1.4MHz-16QAM-23095-6RB#0



BUREAU VERITAS

Test Report No.: PSU-NQN2311090109RF03

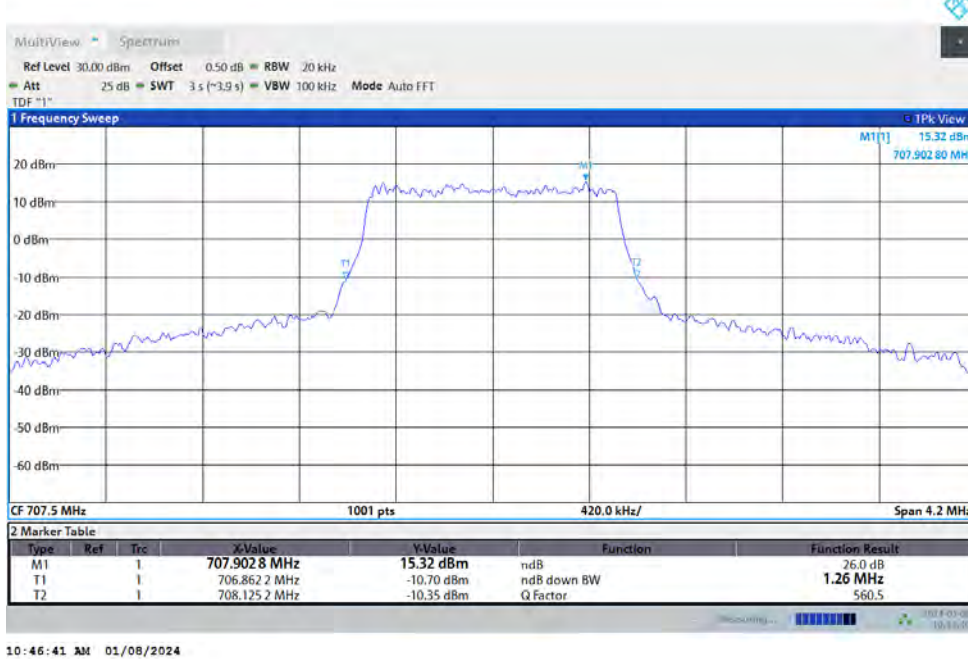

Band12-1.4MHz-64QAM-23095-6RB#0

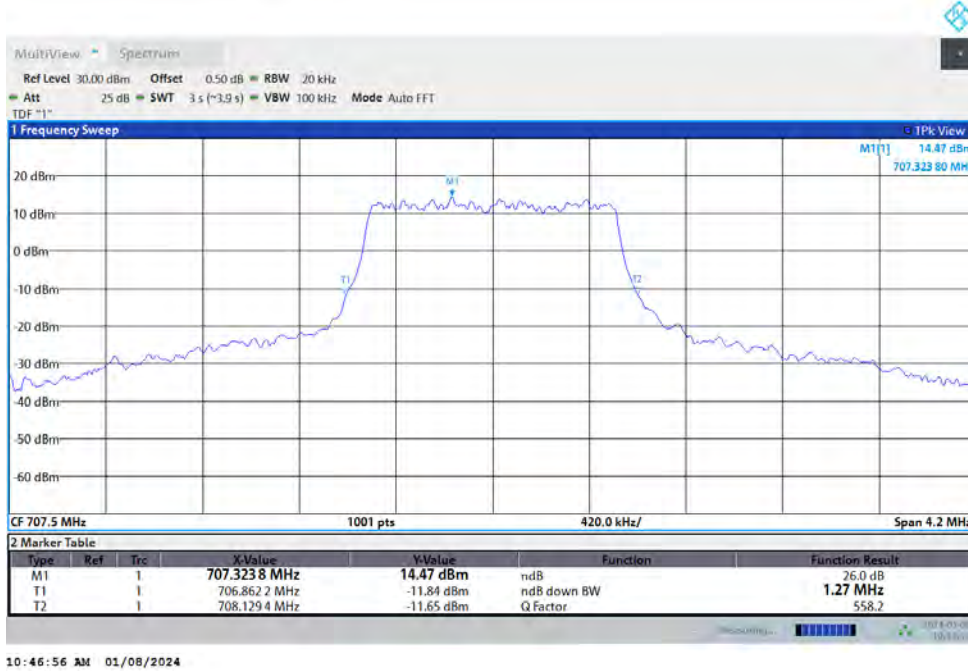

Band12-1.4MHz-QPSK-23173-6RB#0



BUREAU VERITAS

Test Report No.: PSU-NQN2311090109RF03

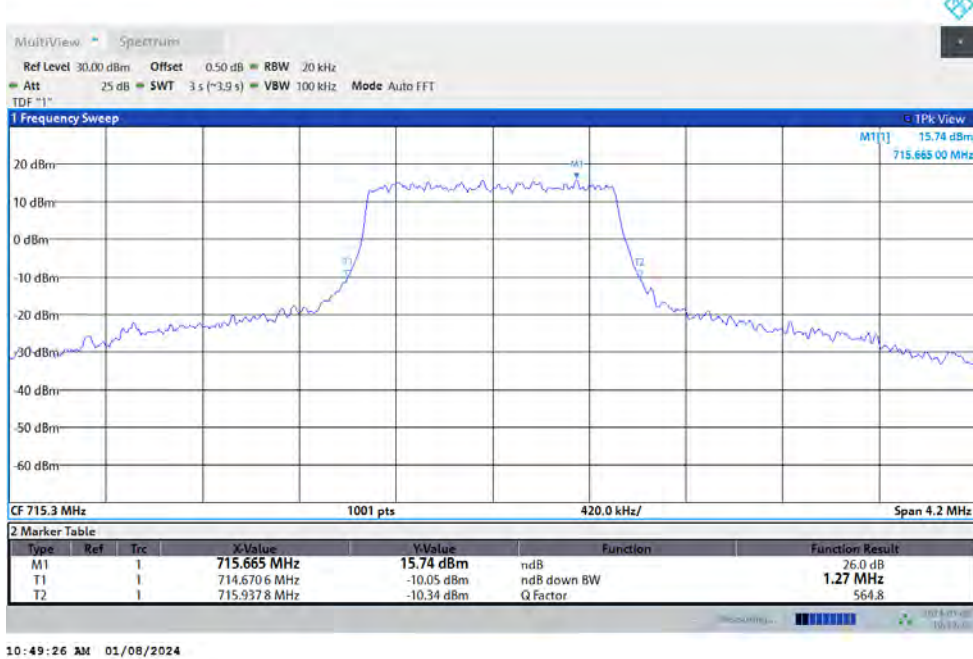

10:49:26 AM 01/08/2024

Band12-1.4MHz-16QAM-23173-6RB#0

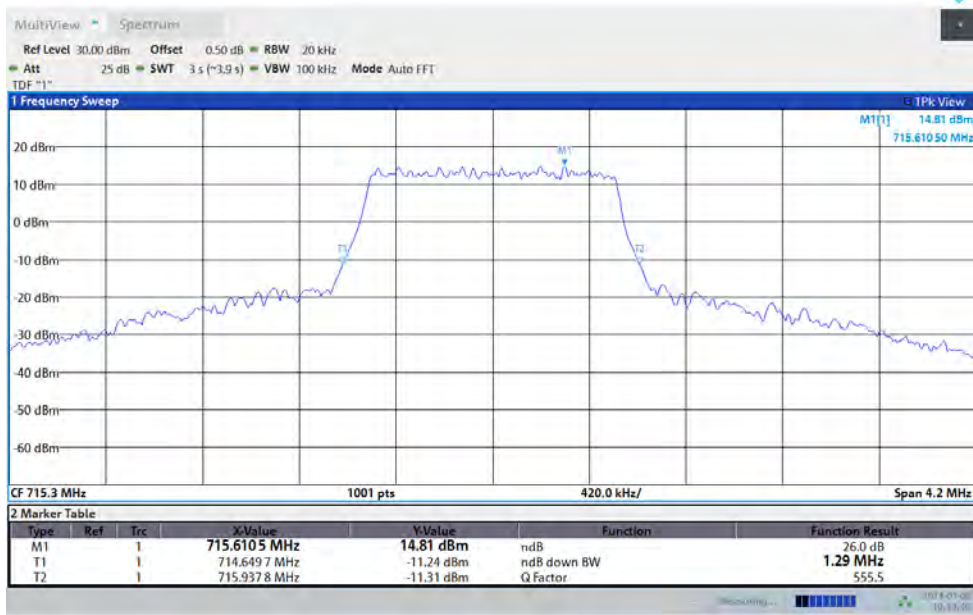

10:49:40 AM 01/08/2024

Band12-1.4MHz-64QAM-23173-6RB#0



**BUREAU
VERITAS**

Test Report No.: PSU-NQN2311090109RF03



10:49:55 AM 01/08/2024

Band12-3MHz-QPSK-23025-15RB#0



10:50:49 AM 01/08/2024

Band12-3MHz-16QAM-23025-15RB#0



BUREAU VERITAS

Test Report No.: PSU-NQN2311090109RF03

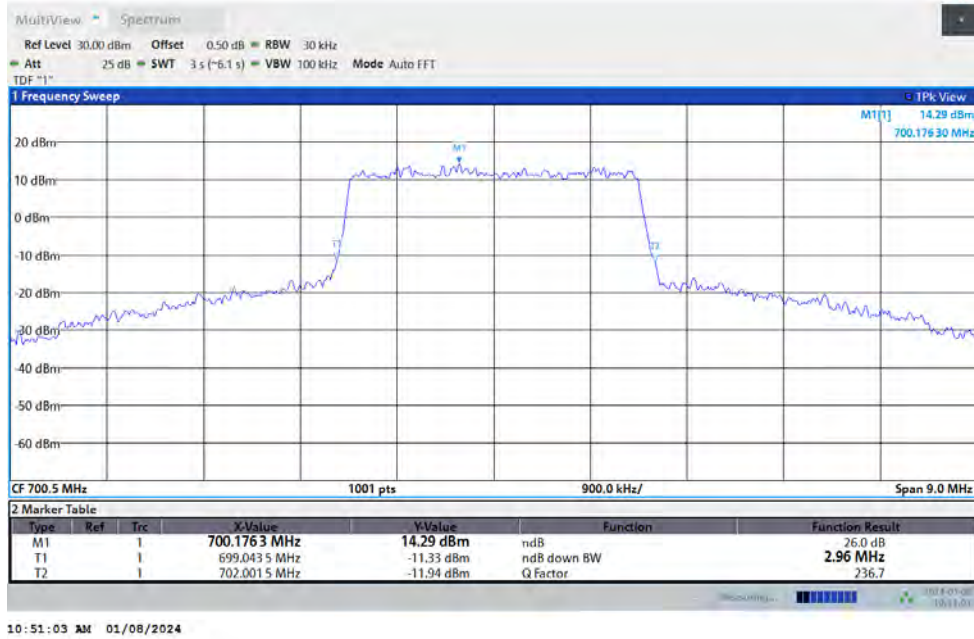

10:51:03 AM 01/08/2024

Band12-3MHz-64QAM-23025-15RB#0



10:51:19 AM 01/08/2024

Band12-3MHz-QPSK-23095-6RB#0



BUREAU VERITAS

Test Report No.: PSU-NQN2311090109RF03

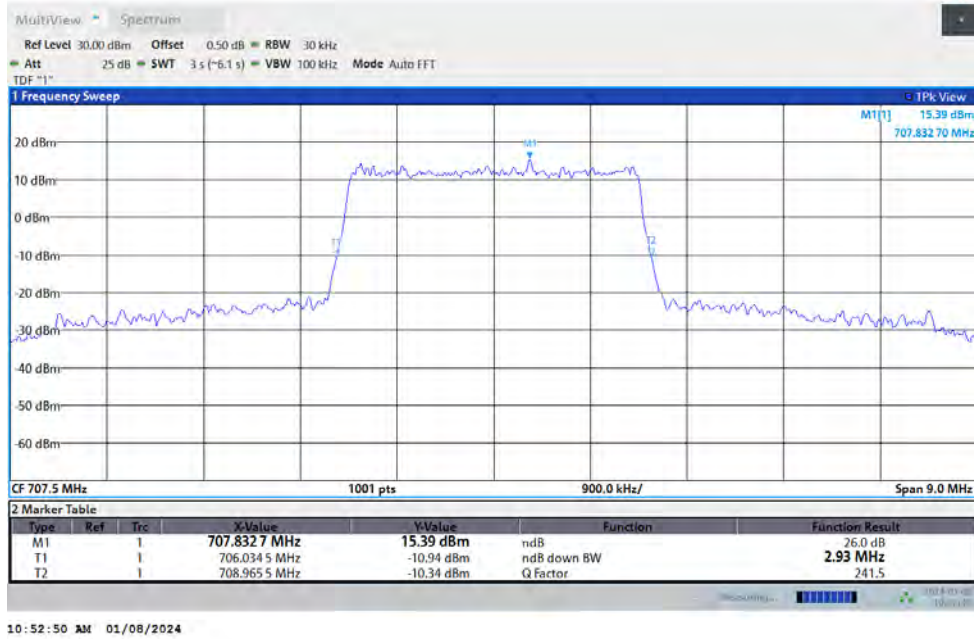

10:52:50 AM 01/08/2024

Band12-3MHz-16QAM-23095-6RB#0



10:53:04 AM 01/08/2024

Band12-3MHz-64QAM-23095-6RB#0



**BUREAU
VERITAS**

Test Report No.: PSU-NQN2311090109RF03

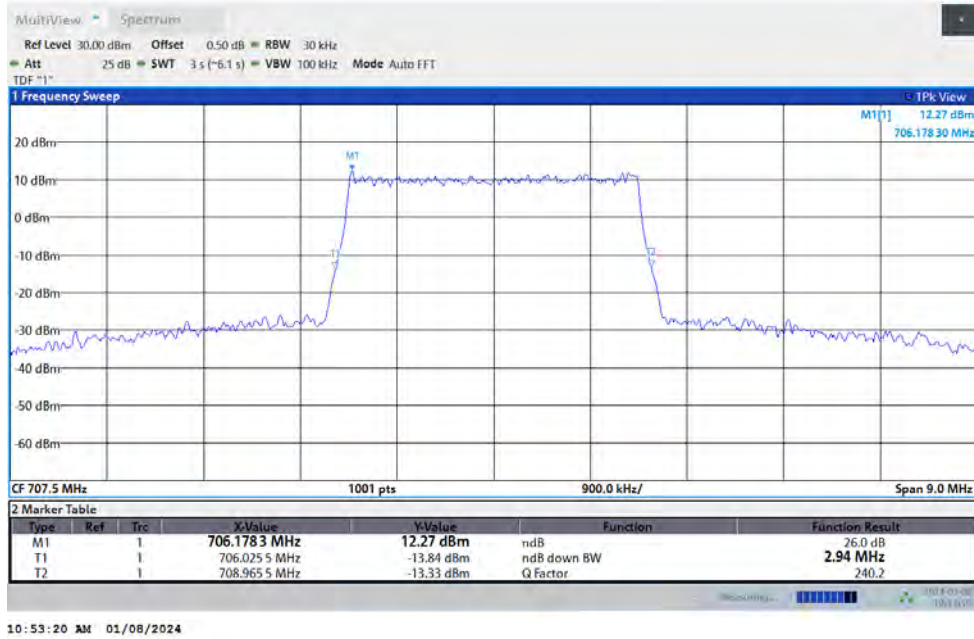

Band12-3MHz-QPSK-23165-15RB#0



Band12-3MHz-16QAM-23165-15RB#0



BUREAU VERITAS

Test Report No.: PSU-NQN2311090109RF03

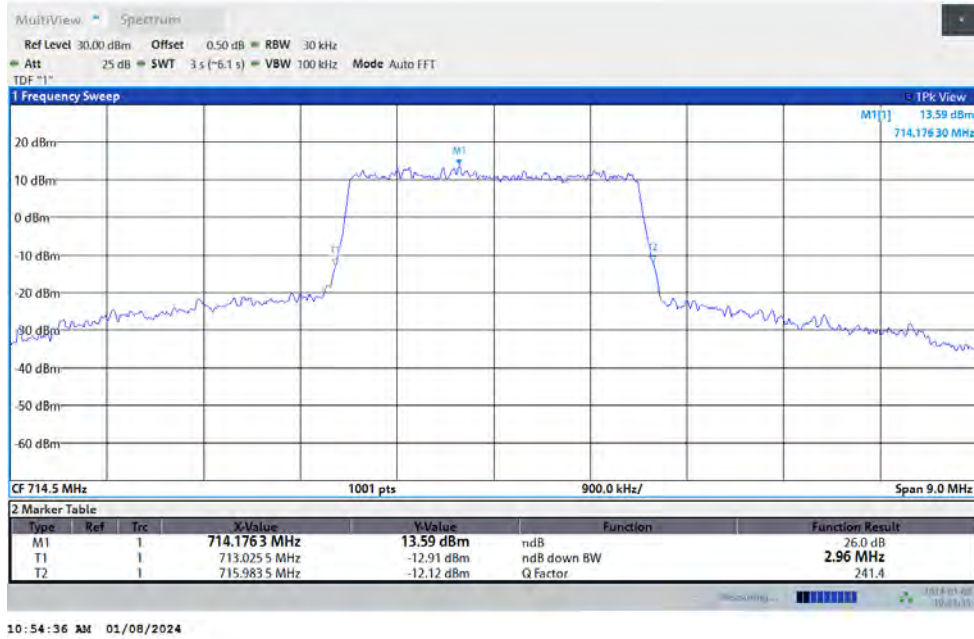

10:54:36 AM 01/08/2024

Band12-3MHz-64QAM-23165-15RB#0

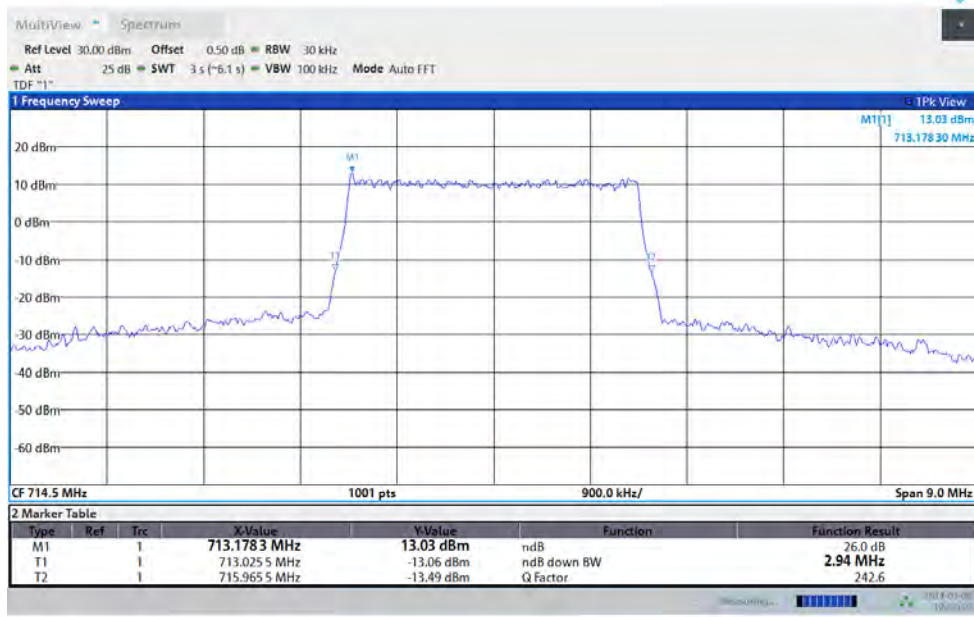

10:54:51 AM 01/08/2024

Band12-5MHz-QPSK-23035-25RB#0



BUREAU VERITAS

Test Report No.: PSU-NQN2311090109RF03

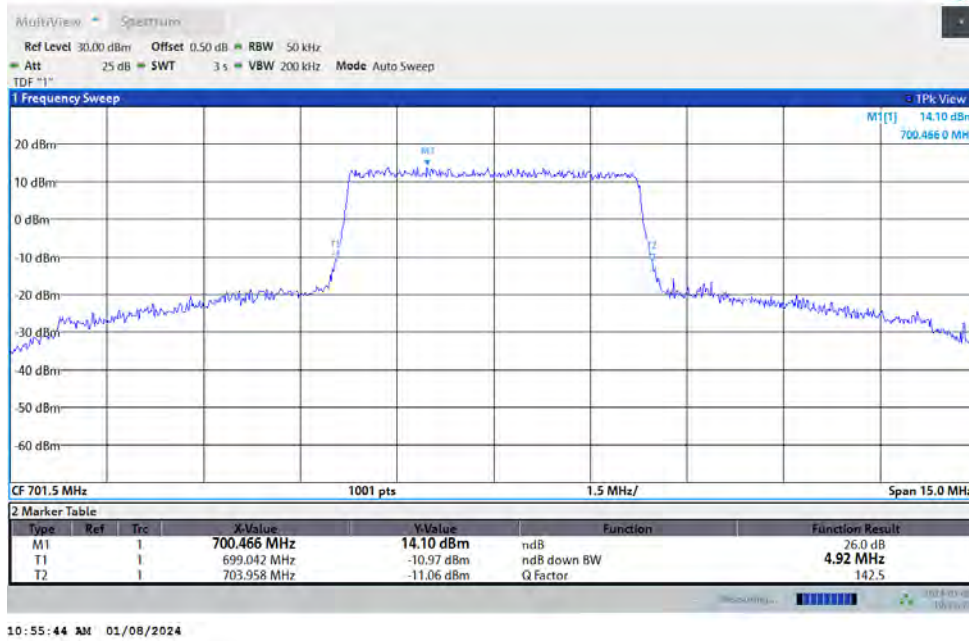

Band12-5MHz-16QAM-23035-25RB#0

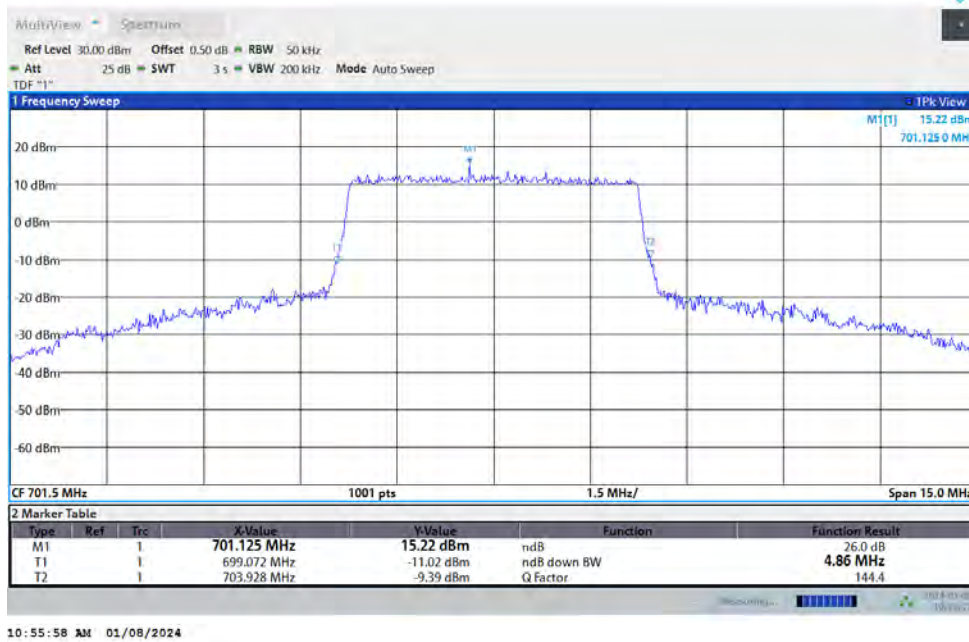

Band12-5MHz-64QAM-23035-25RB#0



BUREAU VERITAS

Test Report No.: PSU-NQN2311090109RF03

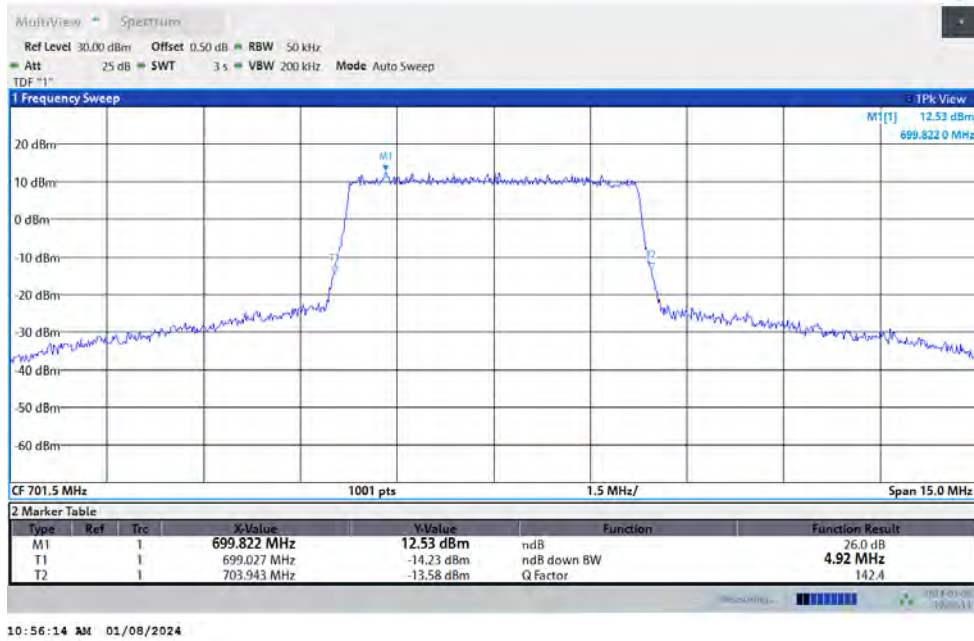

Band12-5MHz-QPSK-23095-25RB#0

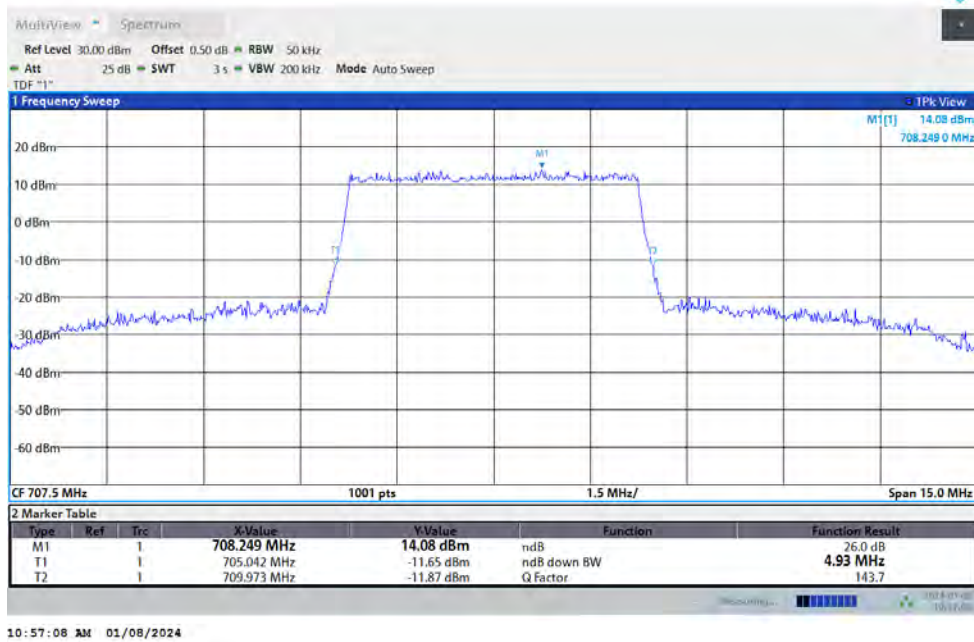

Band12-5MHz-16QAM-23095-6RB#0



**BUREAU
VERITAS**

Test Report No.: PSU-NQN2311090109RF03

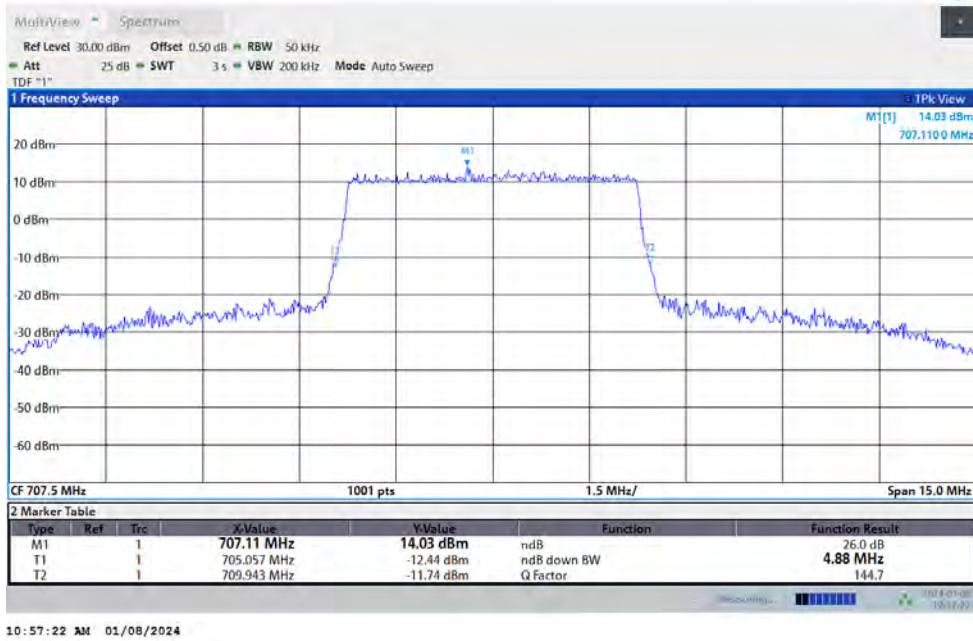

10:57:22 AM 01/08/2024

Band12-5MHz-64QAM-23095-6RB#0

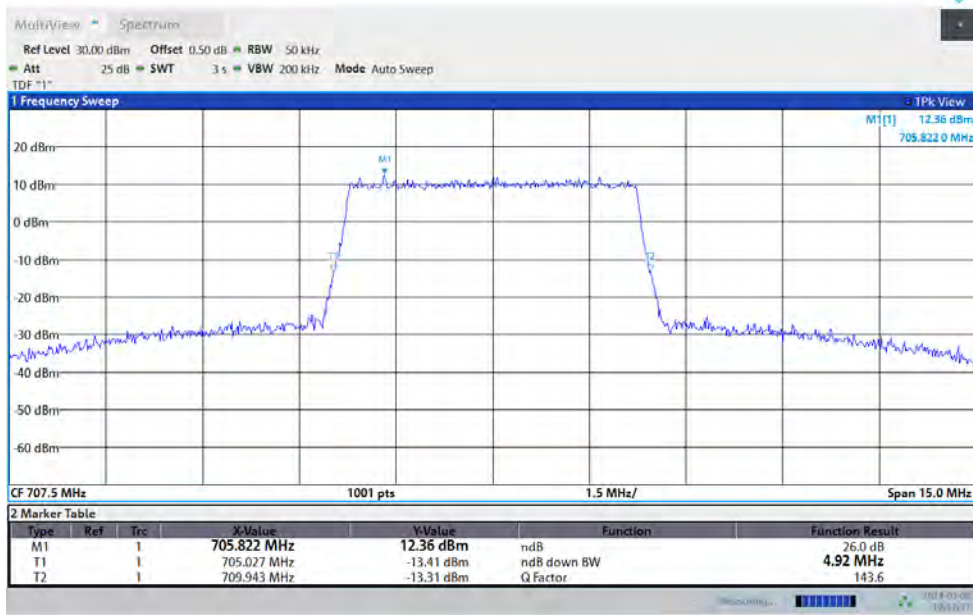

10:57:37 AM 01/08/2024

Band12-5MHz-QPSK-23155-25RB#0



**BUREAU
VERITAS**

Test Report No.: PSU-NQN2311090109RF03

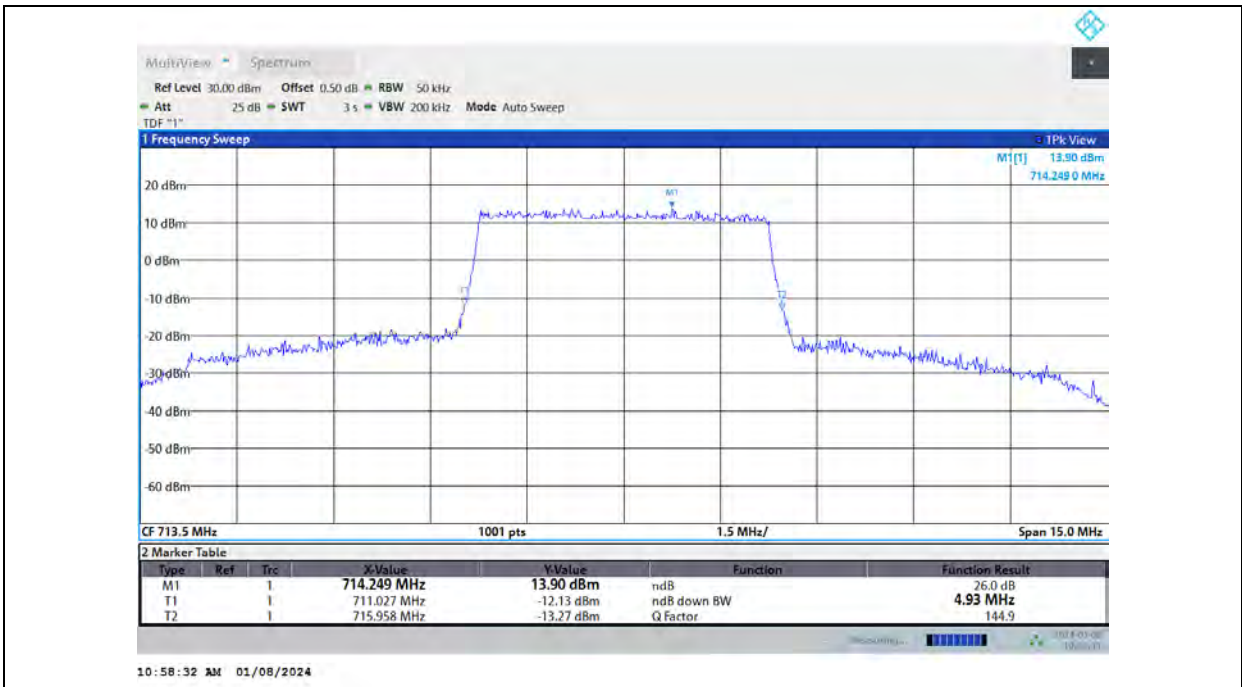

Band12-5MHz-16QAM-23155-25RB#0

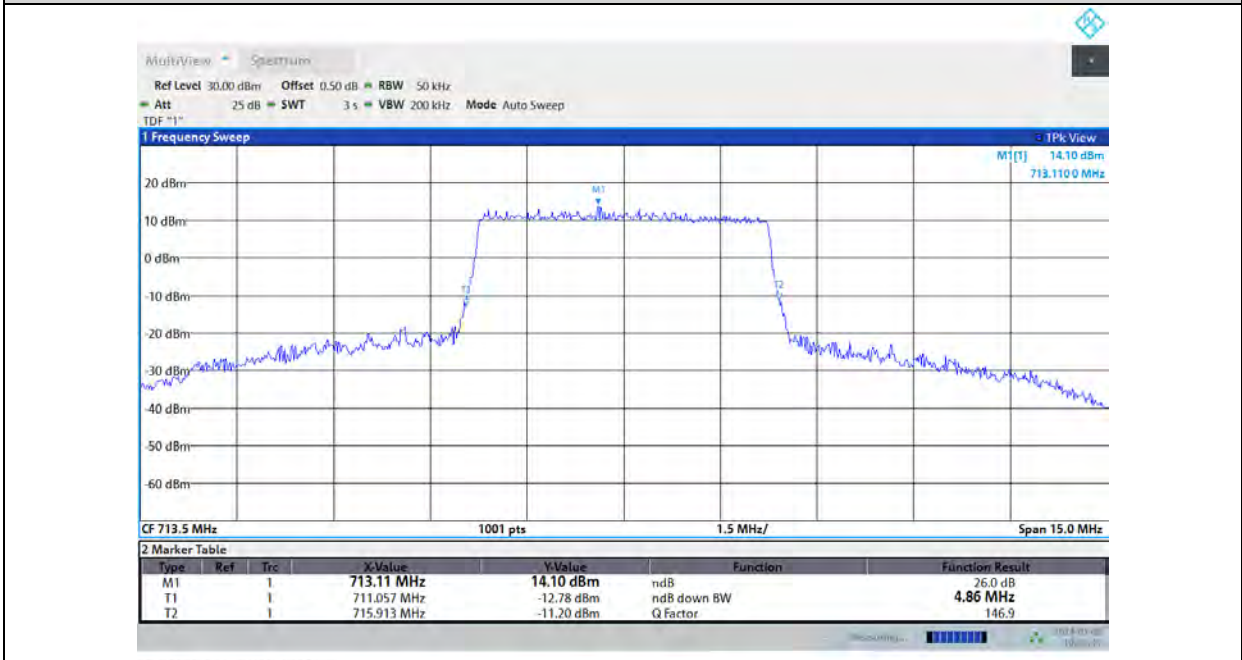

Band12-5MHz-64QAM-23155-25RB#0



**BUREAU
VERITAS**

Test Report No.: PSU-NQN2311090109RF03

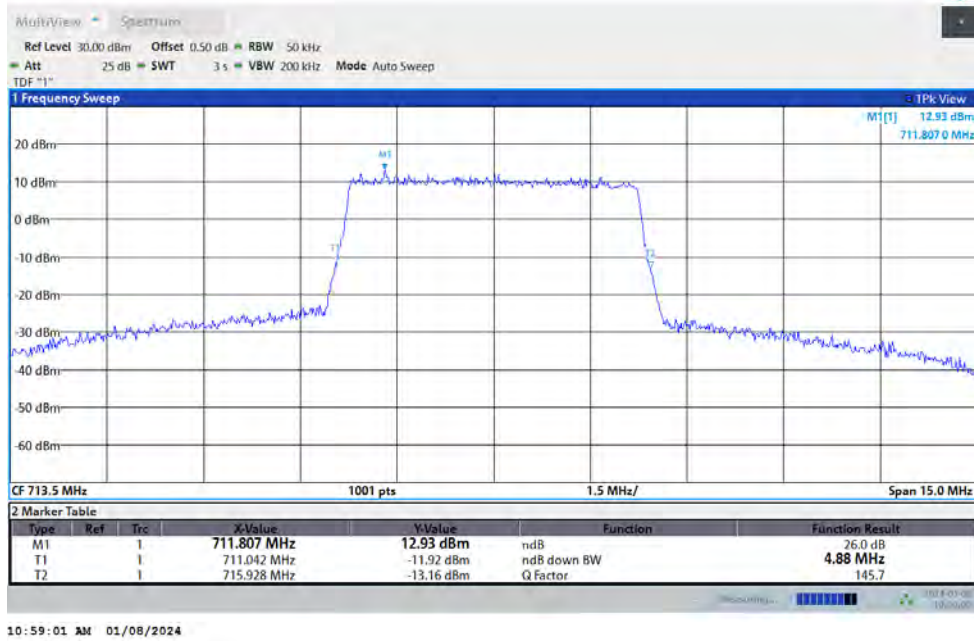

Band12-10MHz-QPSK-23060-50RB#0

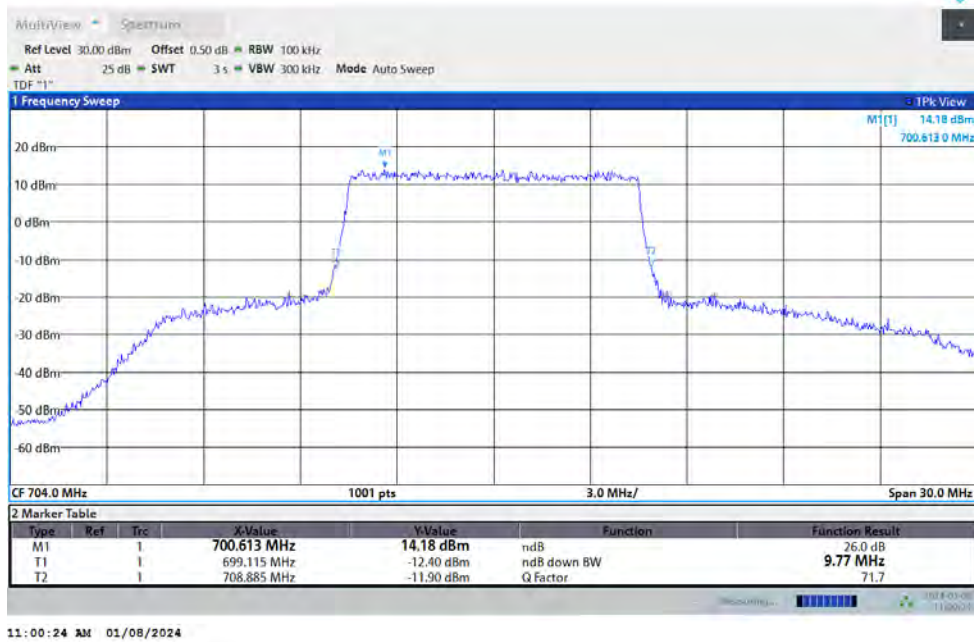

Band12-10MHz-16QAM-23060-50RB#0



BUREAU VERITAS

Test Report No.: PSU-NQN2311090109RF03

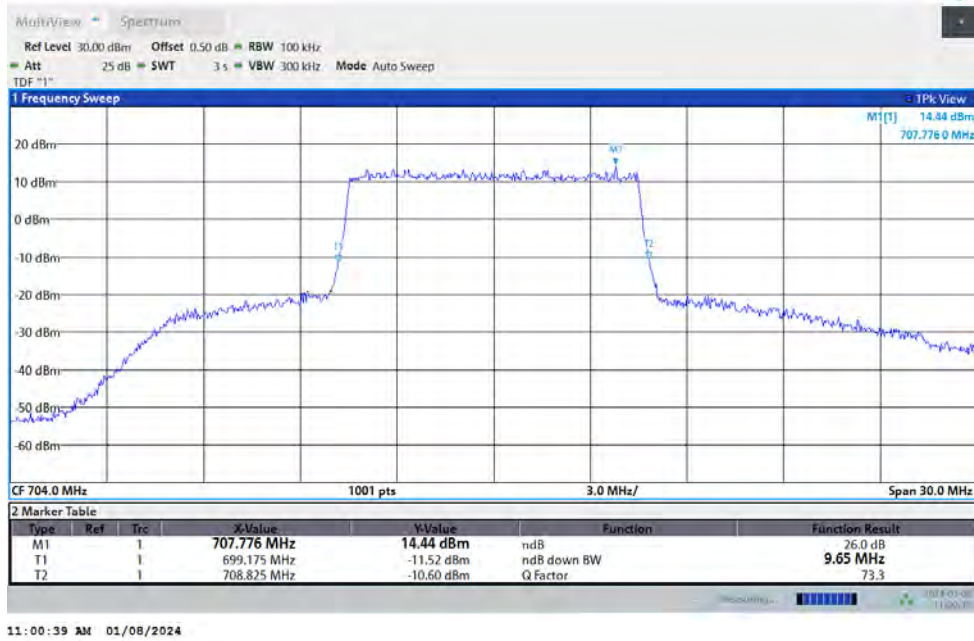

11:00:39 AM 01/08/2024

Band12-10MHz-64QAM-23060-50RB#0

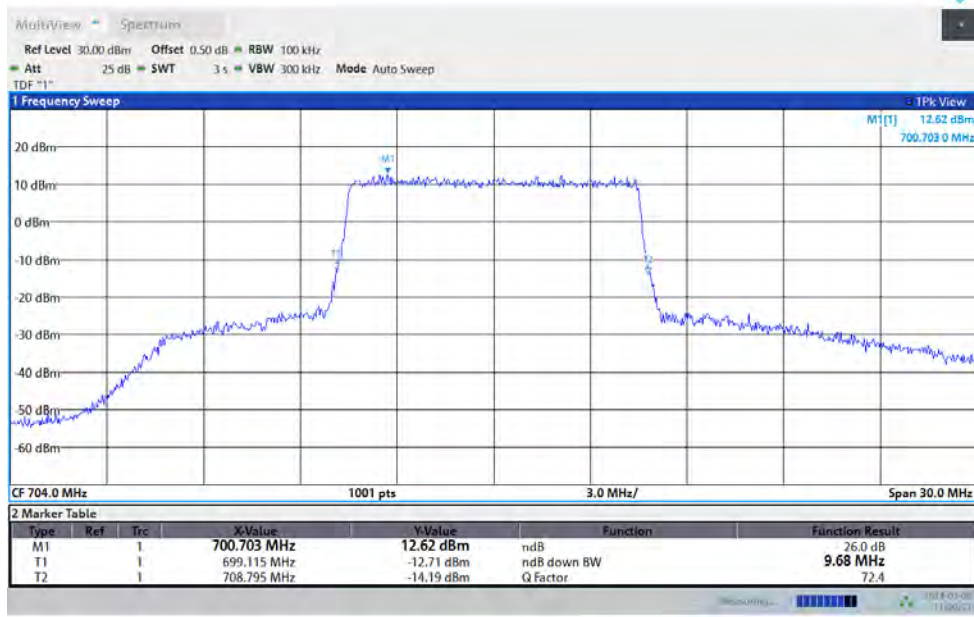

11:00:54 AM 01/08/2024

Band12-10MHz-QPSK-23095-50RB#0



BUREAU VERITAS

Test Report No.: PSU-NQN2311090109RF03

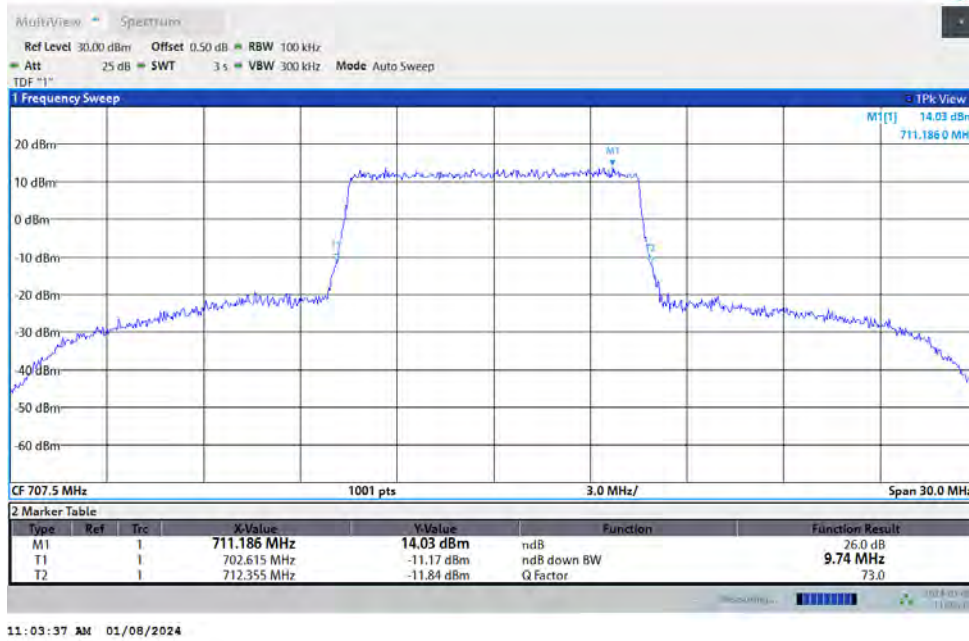

11:03:37 AM 01/08/2024

Band12-10MHz-16QAM-23095-50RB#0

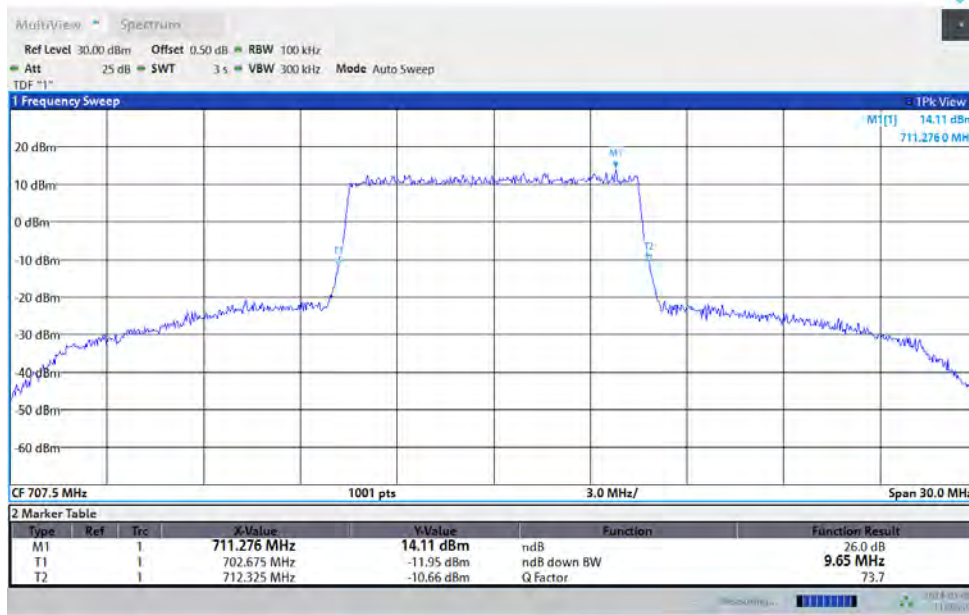

11:03:51 AM 01/08/2024

Band12-10MHz-64QAM-23095-50RB#0



BUREAU VERITAS

Test Report No.: PSU-NQN2311090109RF03

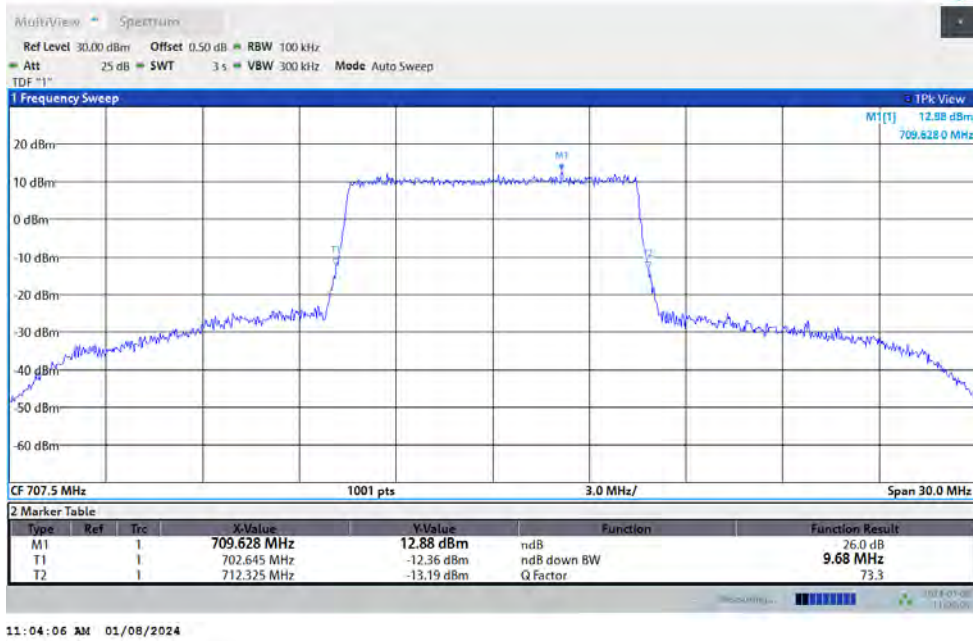

11:04:06 AM 01/08/2024

Band12-10MHz-QPSK-23130-50RB#0

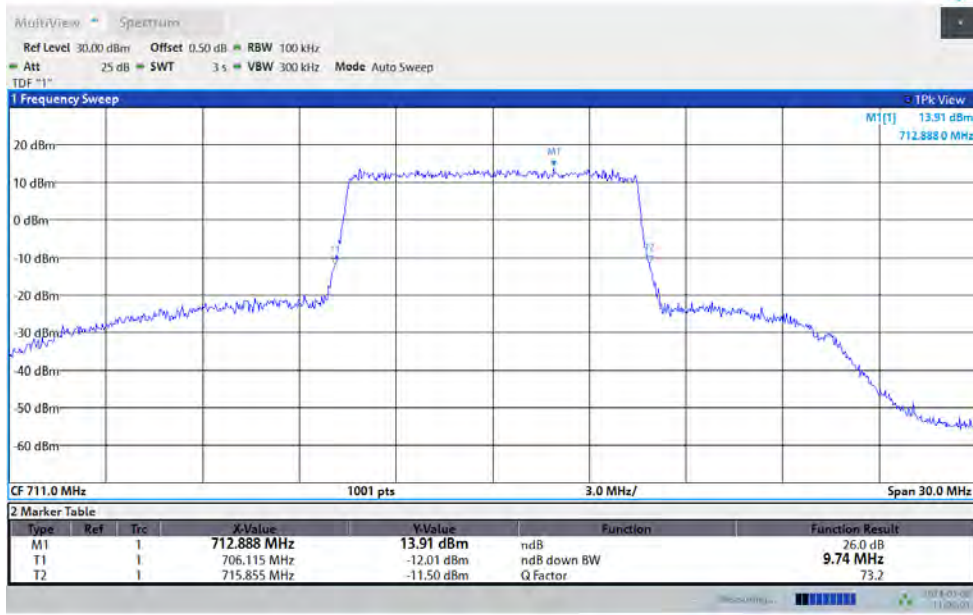

11:05:01 AM 01/08/2024

Band12-10MHz-16QAM-23130-50RB#0