

FCC SAR Test Report

Report No. : PSU-NQN2311090109SA01
Applicant : HMD Global Oy
Address : Bertel Jungin aukio 9 Espoo 02600 Finland
Manufacturer : HMD Global Oy
Address : Bertel Jungin aukio 9 Espoo 02600 Finland
Product : Smartphone
FCC ID : 2AJOTTA-1590
Brand : HMD
Model No. : N159V
Standards : FCC 47 CFR Part 2 (2.1093) / IEEE C95.1:1992 / IEEE 1528:2013
KDB 865664 D01 v01r04 / KDB 865664 D02 v01r02 / KDB 248227 D01 v02r02
KDB 447498 D04 v01 / KDB 648474 D04 v01r03 / KDB 941225 D01 v03r01
KDB 941225 D05 v02r05 / KDB 941225 D05A v01r02 / KDB 941225 D06 v02r01
Sample Received Date : Jan. 02, 2024
Date of Testing : Jan. 04, 2024 ~ Jan. 26, 2024
FCC Designation No. : CN1325 FCC Site Registration No. : 434559

CERTIFICATION: The above equipment have been tested by **Huarui 7layers High Technology (Suzhou) Co., Ltd.**, and found compliance with the requirement of the above standards. The test record, data evaluation & Equipment Under Test (EUT) configurations represented herein are true and accurate accounts of the measurements of the sample's SAR characteristics under the conditions specified in this report. It should not be reproduced except in full, without the written approval of our laboratory. The client should not use it to claim product certification, approval, or endorsement by A2LA or any government agencies.

Prepared By : Chao Wu / Engineer
Approved By : Peibo Sun / Manager

This report is governed by, and incorporates by reference, CPS Conditions of Service as posted at the date of issuance of this report at <http://www.bureauveritas.com/home/about-us/our-business/cps/about-us/terms-conditions> and is intended for your exclusive use. Any copying or replication of this report to or for any other person or entity, or use of our name or trademark, is permitted only with our prior written permission. This report sets forth our findings solely with respect to the test samples identified herein. The results set forth in this report are not indicative or representative of the quality or characteristics of the lot from which a test sample was taken or any similar or identical product unless specifically and expressly noted. Our report includes all of the tests requested by you and the results thereof based upon the information that you provided to us. Measurement uncertainty is only provided upon request for accredited tests. You have 60 days from date of issuance of this report to notify us of any material error or omission caused by our negligence or if you require measurement uncertainty; provided, however, that such notice shall be in writing and shall specifically address the issue you wish to raise. A failure to raise such issue within the prescribed time shall constitute your unqualified acceptance of the completeness of this report, the tests conducted and the correctness of the report contents.

Table of Contents

Release Control Record	3
1. Summary of Maximum SAR Value	4
2. Description of Equipment Under Test	5
3. SAR Measurement System	7
3.1 Definition of Specific Absorption Rate (SAR)	7
3.2 SPEAG DASY System	7
Robot	8
Probes	8
Data Acquisition Electronics (DAE)	9
Phantoms	10
Device Holder	11
System Validation Dipoles	11
Tissue Simulating Liquids	12
3.3 SAR System Verification	14
3.4 SAR Measurement Procedure	15
Area & Zoom Scan Procedure	15
Volume Scan Procedure	15
Power Drift Monitoring	16
Spatial Peak SAR Evaluation	16
SAR Averaged Methods	16
4. SAR Measurement Evaluation	17
4.1 EUT Configuration and Setting	17
4.2 EUT Testing Position	41
4.2.1 Head Exposure Conditions	41
4.2.2 Body-worn Accessory Exposure Conditions	43
4.2.3 Hotspot Mode Exposure Conditions	44
4.2.4 Extremity Exposure Conditions	45
4.2.5 Simultaneous Transmission Possibilities	45
4.3 Tissue Verification	46
4.4 System Verification	47
4.5 Maximum Output Power	48
4.5.1 Maximum Conducted Power	48
4.5.2 Measured Conducted Power Result	48
4.6 SAR Testing Results	48
4.6.1 SAR Test Reduction Considerations	48
4.6.2 SAR Results for Head Exposure Condition	50
4.6.3 SAR Results for Body-worn Exposure Condition (Separation Distance is 1.0 cm Gap)	53
4.6.4 SAR Results for Hotspot Exposure Condition (Separation Distance is 1.0 cm Gap)	54
4.6.5 SAR Results for Extremity Exposure Condition (Separation Distance is 0 cm Gap)	56
4.6.6 SAR Measurement Variability	58
4.6.7 Simultaneous Multi-band Transmission Evaluation	59
5. Calibration of Test Equipment	64
6. Measurement Uncertainty	65
7. Information on the Testing Laboratories	67
Appendix A. SAR Plots of System Verification	
Appendix B. SAR Plots of SAR Measurement	
Appendix C. Calibration Certificate for Probe and Dipole	
Appendix D. Conducted Power Result	
Appendix E. Photographs of EUT and Setup	



BUREAU
VERITAS



Release Control Record

Report No.	Reason for Change	Date Issued
PSU-NQN2311090109SA01	Initial release	Feb. 02, 2024

1. Summary of Maximum SAR Value

Equipment Class	Mode	Highest Reported Head SAR _{1g} (W/kg)	Highest Reported Body-worn SAR _{1g} (1.0 cm Gap) (W/kg)	Highest Reported Hotspot SAR _{1g} (1.0 cm Gap) (W/kg)	Highest Reported Extremity SAR _{10g} (0 cm Gap) (W/kg)
PCE	GSM850	0.25	0.32	0.32	N/A
	GSM1900	0.89	0.58	0.84	2.68
	WCDMA II	1.31	0.92	0.91	2.95
	WCDMA V	0.26	0.34	0.34	N/A
	LTE 2	1.41	1.18	0.87	3.48
	LTE 5	0.21	0.41	0.41	N/A
	LTE 12	0.13	0.24	0.24	N/A
	LTE 13	0.13	0.23	0.23	N/A
	LTE 66 / 4	1.33	0.65	0.87	2.70
DTS	2.4G WLAN	1.20	0.57	0.57	N/A
NII	5.2G WLAN	1.12	1.10	0.37	1.14
	5.3G WLAN	1.11	1.41	N/A	2.15
	5.6G WLAN	0.71	0.55	N/A	0.46
	5.8G WLAN	0.65	0.50	0.50	N/A
DSS	Bluetooth	0.26	0.12	0.12	N/A
Highest Simultaneous Transmission SAR		Head (W/kg)	Body-worn (W/kg)	Hotspot (W/kg)	Extremity (W/kg)
		1.43	1.40	1.35	3.48

Note:

- The SAR limit (**Head & Body: SAR_{1g} 1.6 W/kg, Extremity: SAR_{10g} 4.0 W/kg**) for general population / uncontrolled exposure is specified in FCC 47 CFR part 2 (2.1093) and ANSI/IEEE C95.1-1992.

2. Description of Equipment Under Test

EUT Type	Smart Phone
FCC ID	2AJOTTA-1590
Brand Name	HMD
Model Name	N159V
Sample 1 IMEI Code	IMEI 1: 353407230018095
Sample 2 IMEI Code	IMEI 1: 353407230025165
HW Version	V1.0
SW Version	02US_0_101
Tx Frequency Bands (Unit: MHz)	GSM850 : 824.2 ~ 848.8 GSM1900 : 1850.2 ~ 1909.8 WCDMA Band II : 1852.4 ~ 1907.6 WCDMA Band V : 826.4 ~ 846.6 LTE Band 2 : 1850.7 ~ 1909.3 LTE Band 4 : 1710.7 ~ 1754.3 LTE Band 5 : 824.7 ~ 848.3 LTE Band 12 : 699.7 ~ 715.3 LTE Band 13 : 779.5 ~ 784.5 LTE Band 66 : 1710.7 ~ 1779.3 WLAN : 2412 ~ 2462, 5180 ~ 5240, 5260 ~ 5320, 5500 ~ 5700, 5745 ~ 5825 Bluetooth : 2402 ~ 2480
Uplink Modulations	GSM & GPRS & EDGE : GMSK, 8PSK WCDMA : QPSK LTE : QPSK, 16QAM, 64QAM 802.11b : DSSS 802.11a/g/n/ac : OFDM Bluetooth : GFSK, $\pi/4$ -DQPSK, 8-DPSK
Antenna Type	WWAN ANT1: PIFA Antenna WWAN ANT4 PIFA Antenna WLAN ANT5: PIFA Antenna WLAN ANT6: PIFA Antenna
EUT Stage	Identical Prototype

Note:

1. The above EUT information is declared by manufacturer and for more detailed features description please refers to the manufacturer's specifications or User's Manual.
2. This device supports both LTE B4 and B66. Since the supported frequency span for LTE B4 falls completely within the LTE B66, they have the same target power, and share the same transmission path, therefore SAR was only assessed for B66.
3. According to the document <Difference of change> provided by the manufacturer, these changes do not affect the RF parameters, so sample 1 is fully tested, and sample 2 verifies the worst case.
4. For WWAN Dsi-3/6 and WLAN Dsi-3/6, when the audio is actively routed through the earpiece receiver on head exposure condition, power reduction will be activated to limit the maximum power.
5. For WWAN Dsi-2/5 and WLAN Dsi-5, when the SAR sensor is detect close to the body sate, power reduction will be activated to limit the maximum power. Proximity sensor triggering distances please refer to section 4.1 of this report.
6. For WWAN Dsi-4 and WLAN Dsi-4, When the hotspot function is enabled, power reduction will be activated to limit the maximum power.



Exposure Condition	WWAN Ant-1			Power Reduce
	Audio Receiver	SAR sensor	SAR Hotspot	
Head	On	N/A	N/A	No
Body	Off	On	On	No

Exposure Condition	WWAN Ant-4			Power Reduce
	Audio Receiver	SAR sensor	SAR Hotspot	
Head	On	N/A	N/A	Yes
Body	Off	On	On	Yes

Exposure Condition	WLAN Ant-5			Power Reduce
	Audio Receiver	SAR sensor	SAR Hotspot	
Head	On	N/A	N/A	Yes
Body	Off	On	On	Yes

Exposure Condition	WLAN Ant-6			Power Reduce
	Audio Receiver	SAR sensor	SAR Hotspot	
Head	On	N/A	N/A	Yes
Body	Off	On	On	Yes

WWAN					
Power Table	Test Scenario	Receiver	Hotspot	SAR P-sensor	Wi-Fi State
Power DSI-3	Standalone Head	On	Off	N/A	Off
Power DSI-6	Combine Head	On	Off	N/A	On
Power DSI-2	Standalone Body Worn	Off	Off	On	Off
Power DSI-5	Combine Body Worn	Off	Off	On	On
Power DSI-4	Standalone / Combine Hotspot	N/A	On	N/A	On
Power DSI-2	Standalone Extremity Limb	Off	Off	On	Off
Power DSI-5	Combine Extremity Limb	Off	Off	On	On

WLAN					
Power Table	Test Scenario	Receiver	Hotspot	SAR P-sensor	WWAN State
Power DSI-3	Standalone Head	On	Off	N/A	Off
Power DSI-6	Combine Head	On	Off	N/A	On
Power DSI-2	Standalone Body Worn	Off	Off	On	Off
Power DSI-5	Combine Body Worn	Off	Off	On	On
Power DSI-5	Standalone / Combine Hotspot	N/A	On	N/A	On
Power DSI-2	Standalone Extremity Limb	Off	Off	On	Off
Power DSI-5	Combine Extremity Limb	Off	Off	On	On

3. SAR Measurement System

3.1 Definition of Specific Absorption Rate (SAR)

SAR is related to the rate at which energy is absorbed per unit mass in an object exposed to a radio field. The SAR distribution in a biological body is complicated and is usually carried out by experimental techniques or numerical modeling. The standard recommends limits for two tiers of groups, occupational/controlled and general population/uncontrolled, based on a person's awareness and ability to exercise control over his or her exposure. In general, occupational/controlled exposure limits are higher than the limits for general population/uncontrolled.

The SAR definition is the time derivative (rate) of the incremental energy (dW) absorbed by (dissipated in) an incremental mass (dm) contained in a volume element (dv) of a given density (ρ). The equation description is as below:

$$\text{SAR} = \frac{d}{dt} \left(\frac{dW}{dm} \right) = \frac{d}{dt} \left(\frac{dW}{\rho dv} \right)$$

SAR is expressed in units of Watts per kilogram (W/kg)

SAR measurement can be related to the electrical field in the tissue by

$$\text{SAR} = \frac{\sigma |E|^2}{\rho}$$

Where: σ is the conductivity of the tissue, ρ is the mass density of the tissue and E is the RMS electrical field strength.

3.2 SPEAG DASY System

DASY system consists of high precision robot, probe alignment sensor, phantom, robot controller, controlled measurement server and near-field probe. The robot includes six axes that can move to the precision position of the DASY5 software defined. The DASY software can define the area that is detected by the probe. The robot is connected to controlled box. Controlled measurement server is connected to the controlled robot box. The DAE includes amplifier, signal multiplexing, AD converter, offset measurement and surface detection. It is connected to the Electro-optical coupler (ECO). The ECO performs the conversion from the optical into digital electric signal of the DAE and transfers data to the PC.

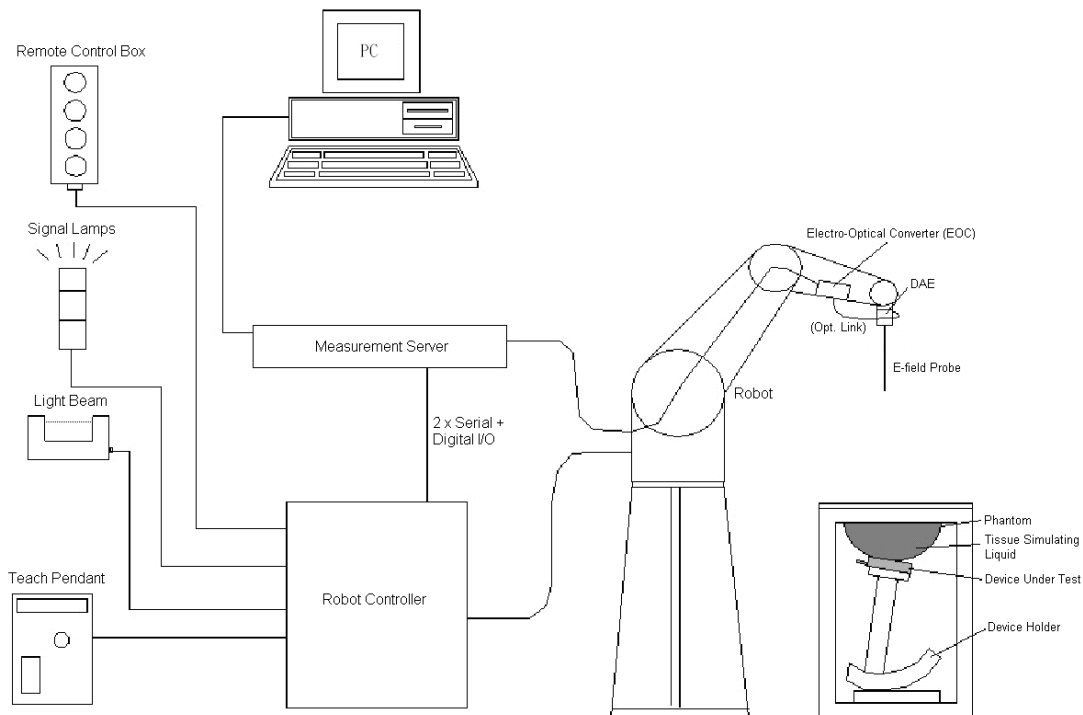

Fig-3.1 DASY System Setup

Robot

The DASY system uses the high precision robots from Stäubli SA (France). For the 6-axis controller system, the robot controller version (DASY6 : CS8c) from Stäubli is used. The Stäubli robot series have many features that are important for our application:

- High precision (repeatability ± 0.035 mm)
- High reliability (industrial design)
- Jerk-free straight movements
- Low ELF interference (the closed metallic construction shields against motor control fields)



Fig-3.2 DASY6

Probes

The SAR measurement is conducted with the dosimetric probe. The probe is specially designed and calibrated for use in liquid with high permittivity. The dosimetric probe has special calibration in liquid at different frequency.

Model	EX3DV4	
Construction	Symmetrical design with triangular core. Built-in shielding against static charges. PEEK enclosure material (resistant to organic solvents, e.g., DGBE).	
Frequency	10 MHz to 6 GHz Linearity: ± 0.2 dB	
Directivity	± 0.3 dB in HSL (rotation around probe axis) ± 0.5 dB in tissue material (rotation normal to probe axis)	
Dynamic Range	10 μ W/g to 100 mW/g Linearity: ± 0.2 dB (noise: typically < 1 μ W/g)	
Dimensions	Overall length: 337 mm (Tip: 20 mm) Tip diameter: 2.5 mm (Body: 12 mm) Typical distance from probe tip to dipole centers: 1 mm	

Model	ES3DV3	
Construction	Symmetrical design with triangular core. Interleaved sensors. Built-in shielding against static charges. PEEK enclosure material (resistant to organic solvents, e.g., DGBE).	
Frequency	10 MHz to 4 GHz Linearity: ± 0.2 dB	
Directivity	± 0.2 dB in HSL (rotation around probe axis) ± 0.3 dB in tissue material (rotation normal to probe axis)	
Dynamic Range	5 μ W/g to 100 mW/g Linearity: ± 0.2 dB	
Dimensions	Overall length: 337 mm (Tip: 20 mm) Tip diameter: 3.9 mm (Body: 12 mm) Distance from probe tip to dipole centers: 2.0 mm	

Data Acquisition Electronics (DAE)

Model	DAE3, DAE4	
Construction	Signal amplifier, multiplexer, A/D converter and control logic. Serial optical link for communication with DASY embedded system (fully remote controlled). Two step probe touch detector for mechanical surface detection and emergency robot stop.	
Measurement Range	-100 to +300 mV (16 bit resolution and two range settings: 4mV, 400mV)	
Input Offset Voltage	< 5 μ V (with auto zero)	
Input Bias Current	< 50 fA	
Dimensions	60 x 60 x 68 mm	

Phantoms

Model	Twin SAM	
Construction	The shell corresponds to the specifications of the Specific Anthropomorphic Mannequin (SAM) phantom defined in IEEE 1528 and IEC 62209-1. It enables the dosimetric evaluation of left and right hand phone usage as well as body mounted usage at the flat phantom region. A cover prevents evaporation of the liquid. Reference markings on the phantom allow the complete setup of all predefined phantom positions and measurement grids by teaching three points with the robot.	
Material	Vinylester, glass fiber reinforced (VE-GF)	
Shell Thickness	2 ± 0.2 mm (6 ± 0.2 mm at ear point)	
Dimensions	Length: 1000 mm Width: 500 mm Height: adjustable feet	
Filling Volume	approx. 25 liters	

Model	ELI	
Construction	Phantom for compliance testing of handheld and body-mounted wireless devices in the frequency range of 30 MHz to 6 GHz. ELI is fully compatible with the IEC 62209-2 standard and all known tissue simulating liquids. ELI has been optimized regarding its performance and can be integrated into our standard phantom tables. A cover prevents evaporation of the liquid. Reference markings on the phantom allow installation of the complete setup, including all predefined phantom positions and measurement grids, by teaching three points. The phantom is compatible with all SPEAG dosimetric probes and dipoles.	
Material	Vinylester, glass fiber reinforced (VE-GF)	
Shell Thickness	2.0 ± 0.2 mm (bottom plate)	
Dimensions	Major axis: 600 mm Minor axis: 400 mm	
Filling Volume	approx. 30 liters	

Device Holder

Model	Mounting Device	
Construction	In combination with the Twin SAM Phantom or ELI4, the Mounting Device enables the rotation of the mounted transmitter device in spherical coordinates. Rotation point is the ear opening point. Transmitter devices can be easily and accurately positioned according to IEC, IEEE, FCC or other specifications. The device holder can be locked for positioning at different phantom sections (left head, right head, flat).	
Material	POM	

Model	Laptop Extensions Kit	
Construction	Simple but effective and easy-to-use extension for Mounting Device that facilitates the testing of larger devices according to IEC 62209-2 (e.g., laptops, cameras, etc.). It is lightweight and fits easily on the upper part of the Mounting Device in place of the phone positioner.	
Material	POM, Acrylic glass, Foam	

System Validation Dipoles

Model	D-Serial	
Construction	Symmetrical dipole with 1/4 balun. Enables measurement of feed point impedance with NWA. Matched for use near flat phantoms filled with tissue simulating solutions.	
Frequency	750 MHz to 5800 MHz	
Return Loss	> 20 dB	
Power Capability	> 100 W (f < 1GHz), > 40 W (f > 1GHz)	

Tissue Simulating Liquids

For SAR measurement of the field distribution inside the phantom, the phantom must be filled with homogeneous tissue simulating liquid to a depth of at least 15 cm. For head SAR testing, the liquid height from the ear reference point (ERP) of the phantom to the liquid top surface is larger than 15 cm. For body SAR testing, the liquid height from the center of the flat phantom to the liquid top surface is larger than 15 cm. The nominal dielectric values of the tissue simulating liquids in the phantom and the tolerance of 5% are listed in Table-3.1.

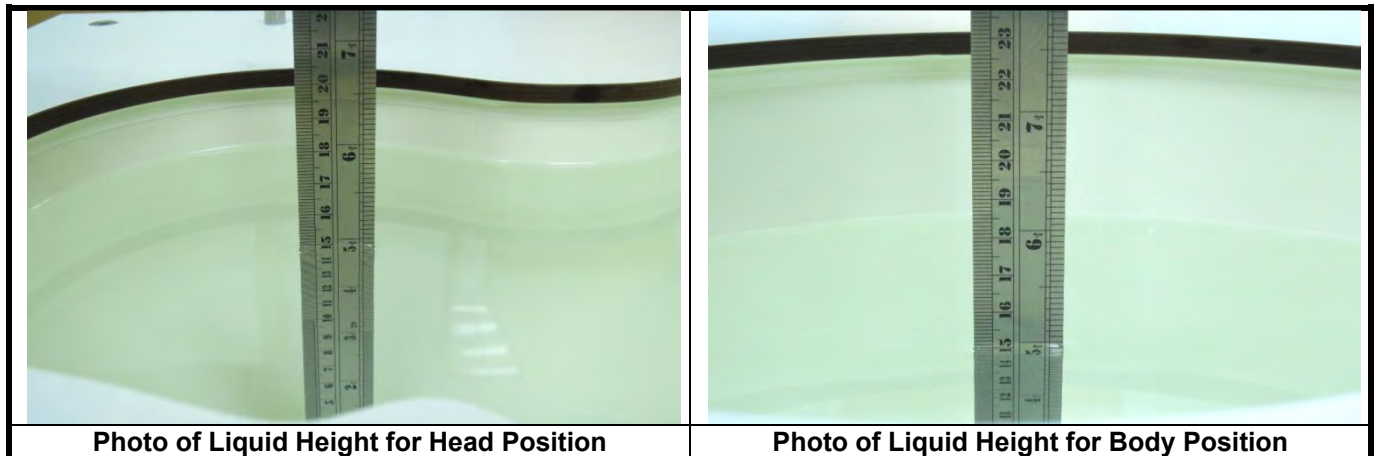

The dielectric properties of the head tissue simulating liquids are defined in IEEE 1528, and KDB 865664 D01 Appendix A. For the body tissue simulating liquids, the dielectric properties are defined in KDB 865664 D01 Appendix A. The dielectric properties of the tissue simulating liquids were verified prior to the SAR evaluation using a dielectric assessment kit and a network analyzer.

Table-3.1 Targets of Tissue Simulating Liquid

Frequency (MHz)	Target Permittivity	Range of $\pm 5\%$	Target Conductivity	Range of $\pm 5\%$
For Head				
750	41.9	39.8 ~ 44.0	0.89	0.85 ~ 0.93
835	41.5	39.4 ~ 43.6	0.90	0.86 ~ 0.95
900	41.5	39.4 ~ 43.6	0.97	0.92 ~ 1.02
1450	40.5	38.5 ~ 42.5	1.20	1.14 ~ 1.26
1640	40.3	38.3 ~ 42.3	1.29	1.23 ~ 1.35
1750	40.1	38.1 ~ 42.1	1.37	1.30 ~ 1.44
1800	40.0	38.0 ~ 42.0	1.40	1.33 ~ 1.47
1900	40.0	38.0 ~ 42.0	1.40	1.33 ~ 1.47
2000	40.0	38.0 ~ 42.0	1.40	1.33 ~ 1.47
2300	39.5	37.5 ~ 41.5	1.67	1.59 ~ 1.75
2450	39.2	37.2 ~ 41.2	1.80	1.71 ~ 1.89
2600	39.0	37.1 ~ 41.0	1.96	1.86 ~ 2.06
3500	37.9	36.0 ~ 39.8	2.91	2.76 ~ 3.06
5200	36.0	34.2 ~ 37.8	4.66	4.43 ~ 4.89
5300	35.9	34.1 ~ 37.7	4.76	4.52 ~ 5.00
5500	35.6	33.8 ~ 37.4	4.96	4.71 ~ 5.21
5600	35.5	33.7 ~ 37.3	5.07	4.82 ~ 5.32
5800	35.3	33.5 ~ 37.1	5.27	5.01 ~ 5.53

The following table gives the recipes for tissue simulating liquids.

Table-3.2 Recipes of Tissue Simulating Liquid

Tissue Type	Bactericide	DGBE	HEC	NaCl	Sucrose	Triton X-100	Water	Diethylene Glycol Mono-hexylether
H750	0.2	-	0.2	1.5	56.0	-	42.1	-
H835	0.2	-	0.2	1.5	57.0	-	41.1	-
H900	0.2	-	0.2	1.4	58.0	-	40.2	-
H1450	-	43.3	-	0.6	-	-	56.1	-
H1640	-	45.8	-	0.5	-	-	53.7	-
H1750	-	47.0	-	0.4	-	-	52.6	-
H1800	-	44.5	-	0.3	-	-	55.2	-
H1900	-	44.5	-	0.2	-	-	55.3	-
H2000	-	44.5	-	0.1	-	-	55.4	-
H2300	-	44.9	-	0.1	-	-	55.0	-
H2450	-	45.0	-	0.1	-	-	54.9	-
H2600	-	45.1	-	0.1	-	-	54.8	-
H3500	-	28.0	-	0.2	-	20.0	71.8	-
H5G	-	-	-	-	-	17.2	65.5	17.3

3.3 SAR System Verification

The system check verifies that the system operates within its specifications. It is performed daily or before every SAR measurement. The system check uses normal SAR measurements in the flat section of the phantom with a matched dipole at a specified distance. The system verification setup is shown as below.

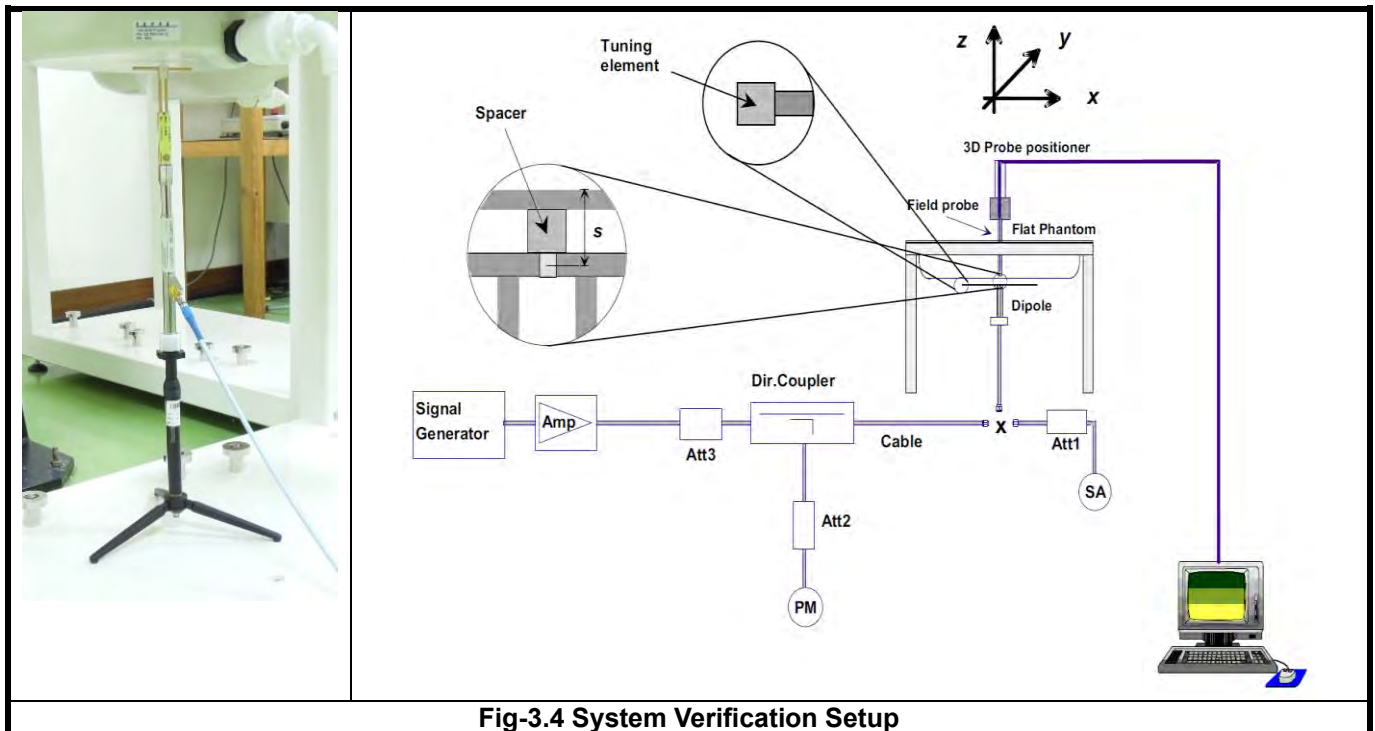

Fig-3.4 System Verification Setup

The validation dipole is placed beneath the flat phantom with the specific spacer in place. The distance spacer is touch the phantom surface with a light pressure at the reference marking and be oriented parallel to the long side of the phantom. The spectrum analyzer measures the forward power at the location of the system check dipole connector. The signal generator is adjusted for the desired forward power (250 mW is used for 700 MHz to 3 GHz, 100 mW is used for 3.5 GHz to 6 GHz) at the dipole connector and the power meter is read at that level. After connecting the cable to the dipole, the signal generator is readjusted for the same reading at power meter.

After system check testing, the SAR result will be normalized to 1W forward input power and compared with the reference SAR value derived from validation dipole certificate report. The deviation of system check should be within 10 %.

3.4 SAR Measurement Procedure

According to the SAR test standard, the recommended procedure for assessing the peak spatial-average SAR value consists of the following steps:

- (a) Power reference measurement
- (b) Area scan
- (c) Zoom scan
- (d) Power drift measurement

The SAR measurement procedures for each of test conditions are as follows:

- (a) Make EUT to transmit maximum output power
- (b) Measure conducted output power through RF cable
- (c) Place the EUT in the specific position of phantom
- (d) Perform SAR testing steps on the DASY system
- (e) Record the SAR value

Area & Zoom Scan Procedure

First Area Scan is used to locate the approximate location(s) of the local peak SAR value(s). The measurement grid within an Area Scan is defined by the grid extent, grid step size and grid offset. Next, in order to determine the EM field distribution in a three-dimensional spatial extension, Zoom Scan is required. The Zoom Scan is performed around the highest E-field value to determine the averaged SAR-distribution over 10 g. According to KDB 865664 D01, the resolution for Area and Zoom scan is specified in the table below.

Items	<= 2 GHz	2-3 GHz	3-4 GHz	4-5 GHz	5-6 GHz
Area Scan ($\Delta x, \Delta y$)	<= 15 mm	<= 12 mm	<= 12 mm	<= 10 mm	<= 10 mm
Zoom Scan ($\Delta x, \Delta y$)	<= 8 mm	<= 5 mm	<= 5 mm	<= 4 mm	<= 4 mm
Zoom Scan (Δz)	<= 5 mm	<= 5 mm	<= 4 mm	<= 3 mm	<= 2 mm
Zoom Scan Volume	>= 30 mm	>= 30 mm	>= 28 mm	>= 25 mm	>= 22 mm

Note:

When zoom scan is required and report SAR is <= 1.4 W/kg, the zoom scan resolution of $\Delta x / \Delta y$ (2-3GHz: <= 8 mm, 3-4GHz: <= 7 mm, 4-6GHz: <= 5 mm) may be applied.

Volume Scan Procedure

The volume scan is used for assess overlapping SAR distributions for antennas transmitting in different frequency bands. It is equivalent to an oversized zoom scan used in standalone measurements. The measurement volume will be used to enclose all the simultaneous transmitting antennas. For antennas transmitting simultaneously in different frequency bands, the volume scan is measured separately in each frequency band. In order to sum correctly to compute the 1g aggregate SAR, the EUT remain in the same test position for all measurements and all volume scan use the same spatial resolution and grid spacing. When all volume scan were completed, the software, SEMCAD postprocessor can combine and subsequently superpose these measurement data to calculating the multiband SAR.

Power Drift Monitoring

All SAR testing is under the EUT install full charged battery and transmit maximum output power. In DASY measurement software, the power reference measurement and power drift measurement procedures are used for monitoring the power drift of EUT during SAR test. Both these procedures measure the field at a specified reference position before and after the SAR testing. The software will calculate the field difference in dB. If the power drift more than 5%, the SAR will be retested.

Spatial Peak SAR Evaluation

The procedure for spatial peak SAR evaluation has been implemented according to the test standard. It can be conducted for 1g and 10g, as well as for user-specific masses. The DASY software includes all numerical procedures necessary to evaluate the spatial peak SAR value.

The base for the evaluation is a "cube" measurement. The measured volume must include the 1g and 10g cubes with the highest averaged SAR values. For that purpose, the center of the measured volume is aligned to the interpolated peak SAR value of a previously performed area scan.

The entire evaluation of the spatial peak values is performed within the post-processing engine (SEMCAD). The system always gives the maximum values for the 1g and 10g cubes. The algorithm to find the cube with highest averaged SAR is divided into the following stages:

- (a) Extraction of the measured data (grid and values) from the Zoom Scan
- (b) Calculation of the SAR value at every measurement point based on all stored data (A/D values and measurement parameters)
- (c) Generation of a high-resolution mesh within the measured volume
- (d) Interpolation of all measured values from the measurement grid to the high-resolution grid
- (e) Extrapolation of the entire 3-D field distribution to the phantom surface over the distance from sensor to surface
- (f) Calculation of the averaged SAR within masses of 1g and 10g

SAR Averaged Methods

In DASY, the interpolation and extrapolation are both based on the modified Quadratic Shepard's method. The interpolation scheme combines a least-square fitted function method and a weighted average method which are the two basic types of computational interpolation and approximation.

Extrapolation routines are used to obtain SAR values between the lowest measurement points and the inner phantom surface. The extrapolation distance is determined by the surface detection distance and the probe sensor offset. The uncertainty increases with the extrapolation distance. To keep the uncertainty within 1% for the 1 g and 10 g cubes, the extrapolation distance should not be larger than 5 mm.

4. SAR Measurement Evaluation

4.1 EUT Configuration and Setting

<Connections between EUT and System Simulator>

For WWAN SAR testing, the EUT was linked and controlled by base station emulator (CMW500 is used for GSM/WCDMA/and LTE). Communication between the EUT and the emulator was established by air link. The distance between the EUT and the communicating antenna of the emulator is larger than 50 cm and the output power radiated from the emulator antenna is at least 30 dB smaller than the output power of EUT. The EUT was set from the emulator to radiate maximum output power during SAR testing.

< Proximity Sensor Triggering Distances >

The proximity sensor triggering distance was determined per KDB 616217 section 6.2, and EUT moving further away from the flat phantom and EUT moving toward the flat phantom were both assessed.

In the preliminary triggering distance testing, the tissue-equivalent medium for different frequency bands were used for verification; no other frequency bands tissue-equivalent medium was found to result in shortest triggering than that for 5700MHz, and the tissue-equivalent medium for 5700MHz was used for formal proximity sensor triggering testing.

Summary for power verification per distance was tabulated in the below table.

DSI-2

Output Power Verification in dBm for EUT Rear Face (moving toward phantom)											
Distance (mm)	28	27	26	25	24	23	22	21	20	19	18
GSM1900 Ch810 (GMSK 4Tx slots)	25.84	25.84	25.84	25.84	25.84	23.10	23.10	23.10	23.10	23.10	23.10
WCDMA B2 Ch9538 (RMC12.2K)	23.69	23.69	23.69	23.69	23.69	20.99	20.99	20.99	20.99	20.99	20.99
LTE 2 Ch18900 (QPSK20M_1RB_OS50)	23.55	23.55	23.55	23.55	23.55	22.10	22.10	22.10	22.10	22.10	22.10
LTE 4 Ch20300 (QPSK20M_1RB_OS99)	23.34	23.34	23.34	23.34	23.34	22.18	22.18	22.18	22.18	22.18	22.18
LTE 66 Ch132322 (QPSK20M_1RB_OS99)	23.45	23.45	23.45	23.45	23.45	21.96	21.96	21.96	21.96	21.96	21.96
WLAN5.2G Ch36 (802.11n-HT20)	16.57	16.57	16.57	16.57	16.57	16.39	16.39	16.39	16.39	16.39	16.39

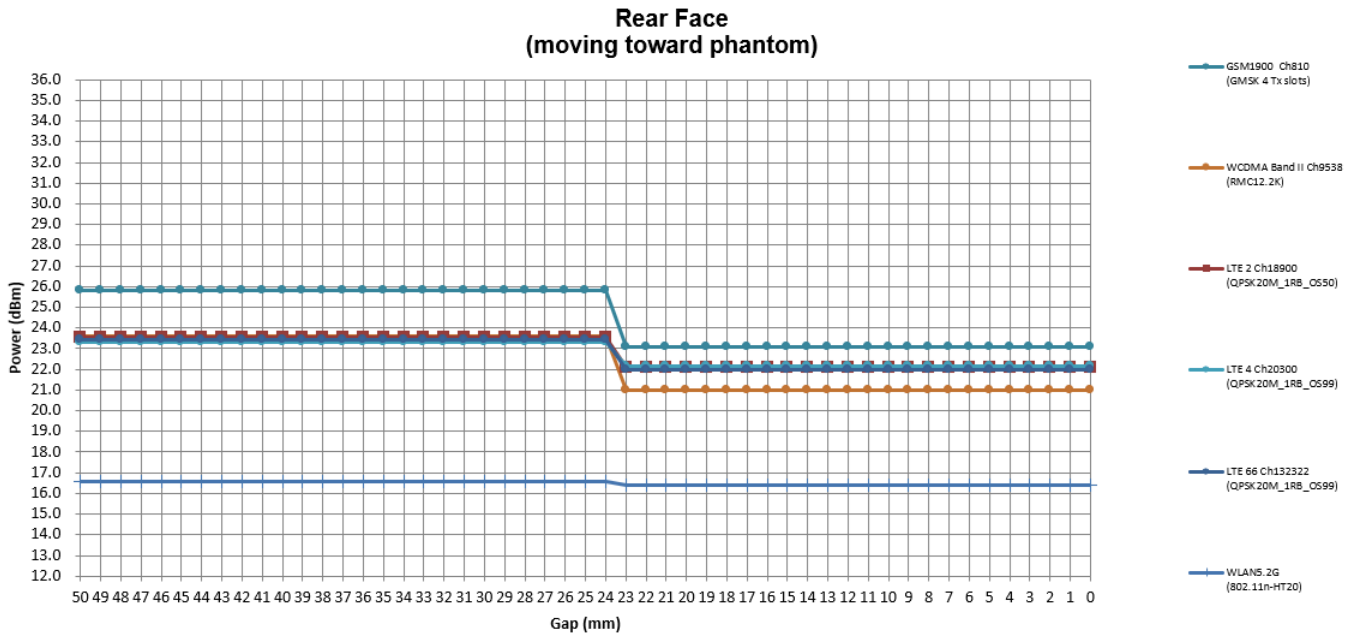

Output Power Verification in dBm for EUT Rear Face (moving away phantom)											
Distance (mm)	21	22	23	24	25	26	27	28	29	30	31
GSM1900 Ch810 (GMSK 4Tx slots)	23.10	23.10	23.10	23.10	23.10	25.84	25.84	25.84	25.84	25.84	25.84
WCDMA B2 Ch9538 (RMC12.2K)	20.99	20.99	20.99	20.99	20.99	23.69	23.69	23.69	23.69	23.69	23.69
LTE 2 Ch18900 (QPSK20M_1RB_OS50)	22.10	22.10	22.10	22.10	22.10	23.55	23.55	23.55	23.55	23.55	23.55
LTE 4 Ch20300 (QPSK20M_1RB_OS99)	22.18	22.18	22.18	22.18	22.18	23.34	23.34	23.34	23.34	23.34	23.34
LTE 66 Ch132322 (QPSK20M_1RB_OS99)	21.96	21.96	21.96	21.96	21.96	23.45	23.45	23.45	23.45	23.45	23.45
WLAN5.2G Ch36 (802.11n-HT20)	16.39	16.39	16.39	16.39	16.39	16.57	16.57	16.57	16.57	16.57	16.57

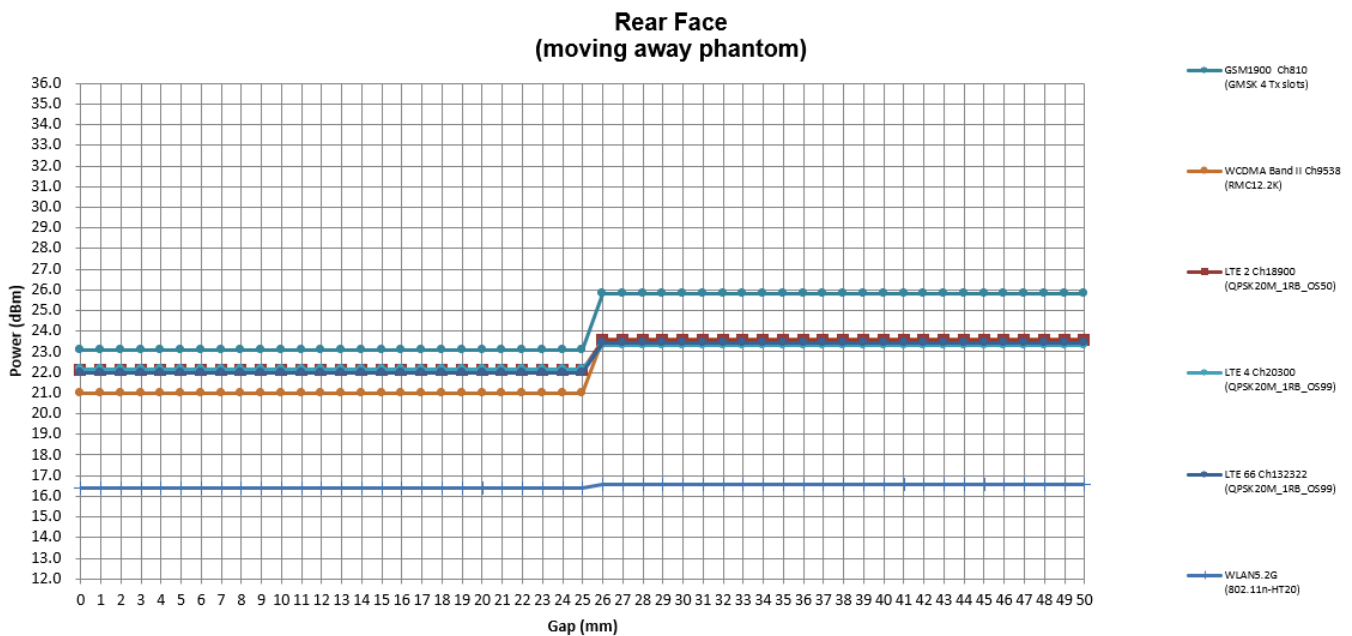

Output Power Verification in dBm for EUT Front
(moving toward phantom)

Distance (mm)	17	16	15	14	13	12	11	10	9	8	7
GSM1900 Ch810 (GMSK 4Tx slots)	25.84	25.84	25.84	25.84	25.84	23.10	23.10	23.10	23.10	23.10	23.10
WCDMA B2 Ch9538 (RMC12.2K)	23.69	23.69	23.69	23.69	23.69	20.99	20.99	20.99	20.99	20.99	20.99
LTE 2 Ch18900 (QPSK20M 1RB_OS50)	23.55	23.55	23.55	23.55	23.55	22.10	22.10	22.10	22.10	22.10	22.10
LTE 4 Ch20300 (QPSK20M 1RB_OS99)	23.34	23.34	23.34	23.34	23.34	22.18	22.18	22.18	22.18	22.18	22.18
LTE 66 Ch132322 (QPSK20M 1RB_OS99)	23.45	23.45	23.45	23.45	23.45	21.96	21.96	21.96	21.96	21.96	21.96
WLAN5.2G Ch36 (802.11n-HT20)	16.57	16.57	16.57	16.57	16.57	16.39	16.39	16.39	16.39	16.39	16.39

Front Face
(moving toward phantom)

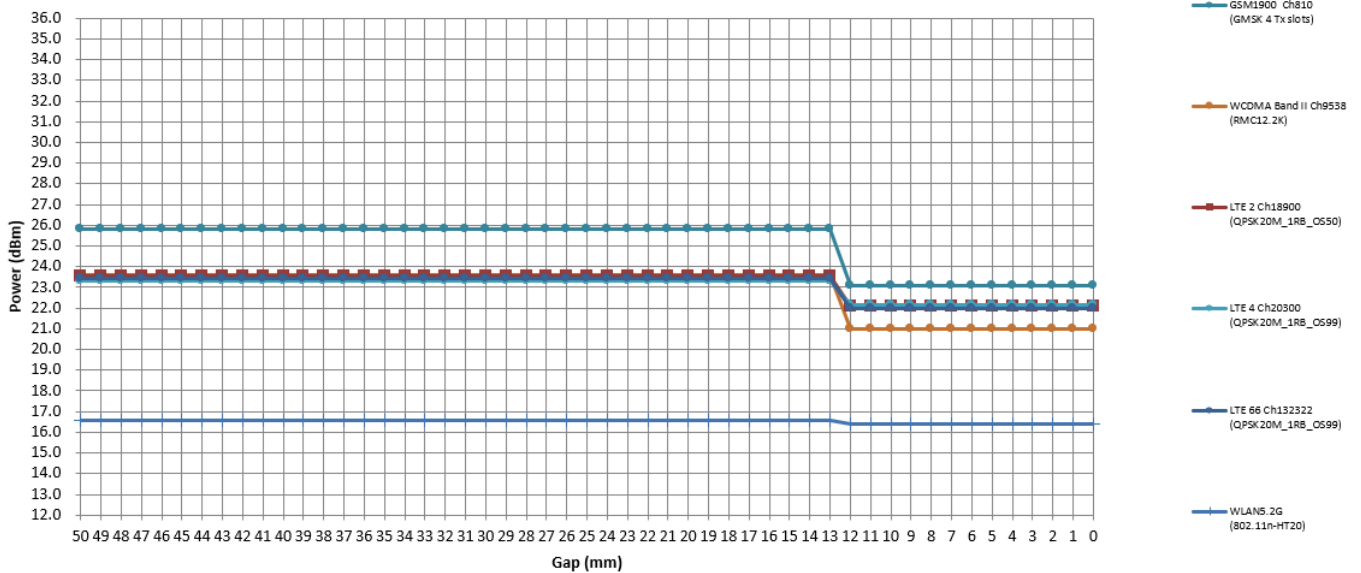

Output Power Verification in dBm for EUT Front Face (moving away phantom)											
Distance (mm)	10	11	12	13	14	15	16	17	18	19	20
GSM1900 Ch810 (GMSK 4Tx slots)	23.10	23.10	23.10	23.10	23.10	25.84	25.84	25.84	25.84	25.84	25.84
WCDMA B2 Ch9538 (RMC12.2K)	20.99	20.99	20.99	20.99	20.99	23.69	23.69	23.69	23.69	23.69	23.69
LTE 2 Ch18900 (QPSK20M_1RB_OS50)	22.10	22.10	22.10	22.10	22.10	23.55	23.55	23.55	23.55	23.55	23.55
LTE 4 Ch20300 (QPSK20M_1RB_OS99)	22.18	22.18	22.18	22.18	22.18	23.34	23.34	23.34	23.34	23.34	23.34
LTE 66 Ch132322 (QPSK20M_1RB_OS99)	21.96	21.96	21.96	21.96	21.96	23.45	23.45	23.45	23.45	23.45	23.45
WLAN5.2G Ch36 (802.11n-HT20)	16.39	16.39	16.39	16.39	16.39	16.57	16.57	16.57	16.57	16.57	16.57

**Front Face
(moving away phantom)**

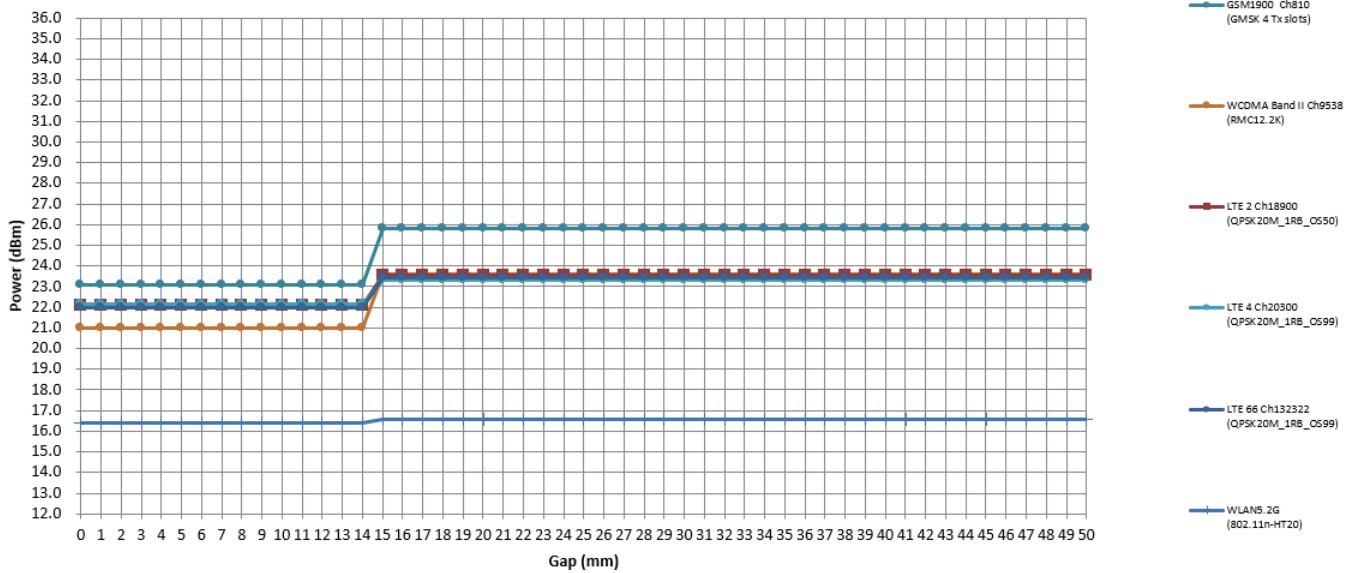

Output Power Verification in dBm for EUT Right Side (moving toward phantom)											
Distance (mm)	28	27	26	25	24	23	22	21	20	19	18
GSM1900 Ch810 (GMSK 4Tx slots)	25.84	25.84	25.84	25.84	25.84	23.10	23.10	23.10	23.10	23.10	23.10
WCDMA B2 Ch9538 (RMC12.2K)	23.69	23.69	23.69	23.69	23.69	20.99	20.99	20.99	20.99	20.99	20.99
LTE 2 Ch18900 (QPSK20M_1RB_OS50)	23.55	23.55	23.55	23.55	23.55	22.10	22.10	22.10	22.10	22.10	22.10
LTE 4 Ch20300 (QPSK20M_1RB_OS99)	23.34	23.34	23.34	23.34	23.34	22.18	22.18	22.18	22.18	22.18	22.18
LTE 66 Ch132322 (QPSK20M_1RB_OS99)	23.45	23.45	23.45	23.45	23.45	21.96	21.96	21.96	21.96	21.96	21.96
WLAN5.2G Ch36 (802.11n-HT20)	16.57	16.57	16.57	16.57	16.57	16.39	16.39	16.39	16.39	16.39	16.39

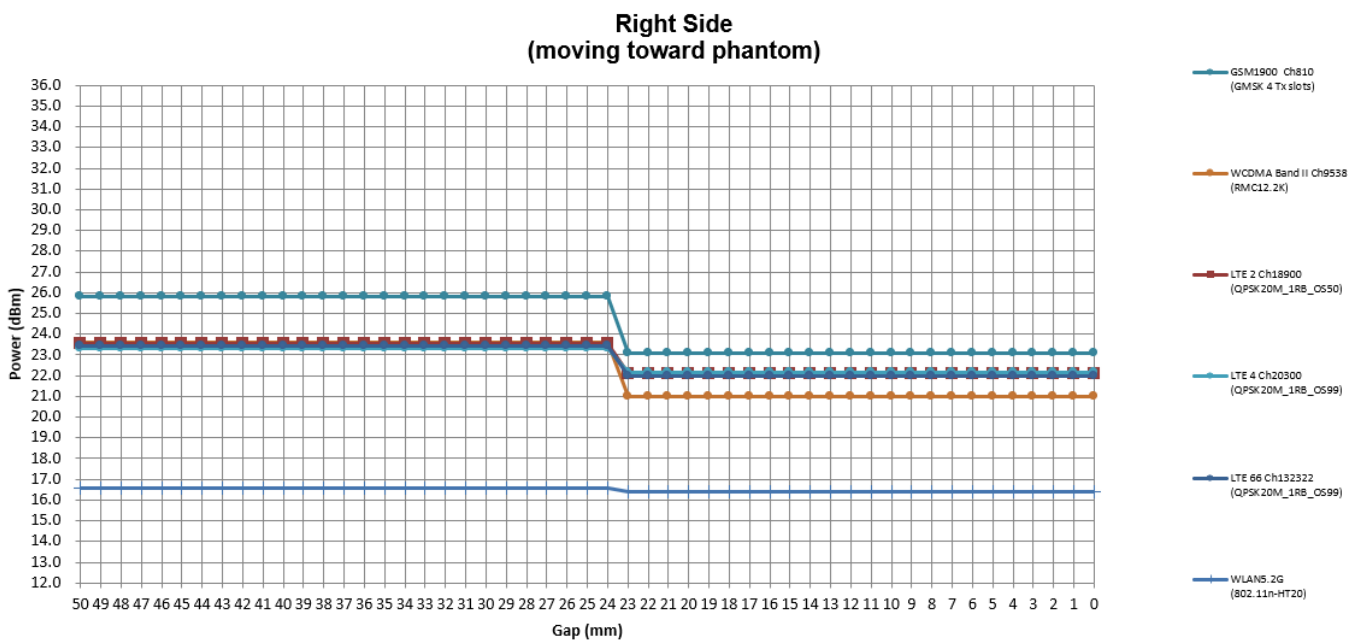

Output Power Verification in dBm for EUT Right Side (moving away phantom)											
Distance (mm)	21	22	23	24	25	26	27	28	29	30	31
GSM1900 Ch810 (GMSK 4Tx slots)	23.10	23.10	23.10	23.10	23.10	25.84	25.84	25.84	25.84	25.84	25.84
WCDMA B2 Ch9538 (RMC12.2K)	20.99	20.99	20.99	20.99	20.99	23.69	23.69	23.69	23.69	23.69	23.69
LTE 2 Ch18900 (QPSK20M_1RB_OS50)	22.10	22.10	22.10	22.10	22.10	23.55	23.55	23.55	23.55	23.55	23.55
LTE 4 Ch20300 (QPSK20M_1RB_OS99)	22.18	22.18	22.18	22.18	22.18	23.34	23.34	23.34	23.34	23.34	23.34
LTE 66 Ch132322 (QPSK20M_1RB_OS99)	21.96	21.96	21.96	21.96	21.96	23.45	23.45	23.45	23.45	23.45	23.45
WLAN5.2G Ch36 (802.11n-HT20)	16.39	16.39	16.39	16.39	16.39	16.57	16.57	16.57	16.57	16.57	16.57

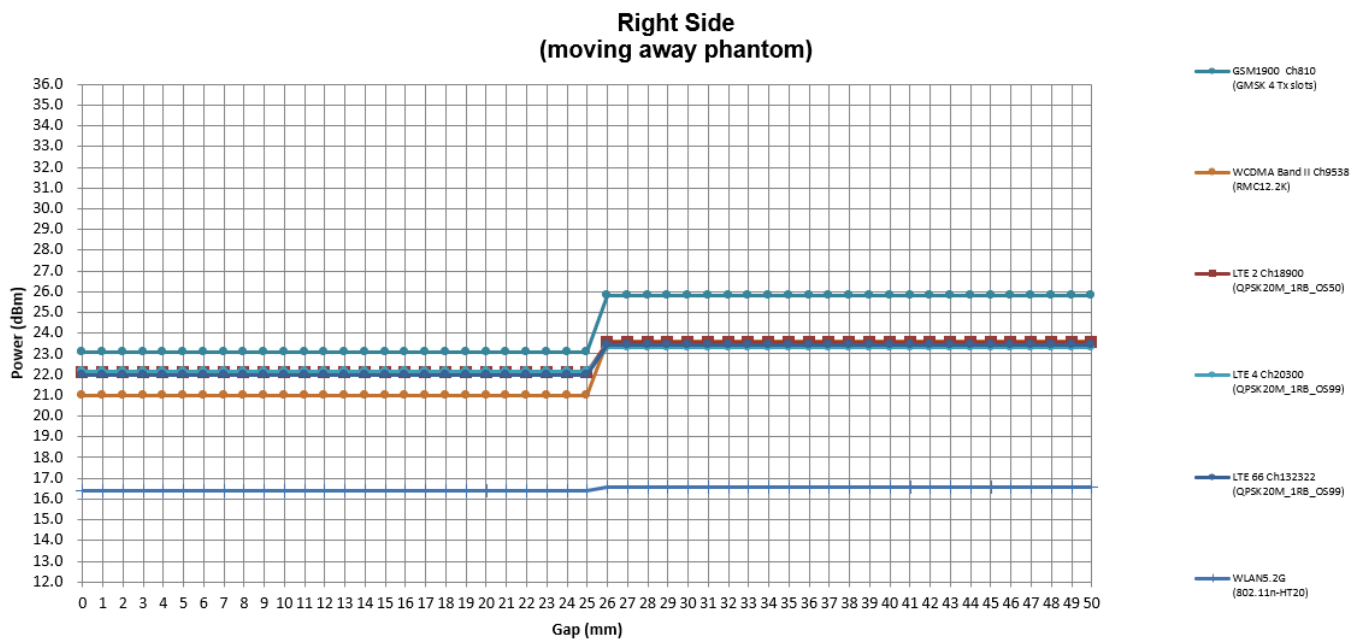

Output Power Verification in dBm for EUT Top Side (moving toward phantom)											
Distance (mm)	25	24	23	22	21	20	19	18	17	16	15
GSM1900 Ch810 (GMSK 4Tx slots)	25.84	25.84	25.84	25.84	25.84	23.10	23.10	23.10	23.10	23.10	23.10
WCDMA B2 Ch9538 (RMC12.2K)	23.69	23.69	23.69	23.69	23.69	20.99	20.99	20.99	20.99	20.99	20.99
LTE 2 Ch18900 (QPSK20M_1RB_OS50)	23.55	23.55	23.55	23.55	23.55	22.10	22.10	22.10	22.10	22.10	22.10
LTE 4 Ch20300 (QPSK20M_1RB_OS99)	23.34	23.34	23.34	23.34	23.34	22.18	22.18	22.18	22.18	22.18	22.18
LTE 66 Ch132322 (QPSK20M_1RB_OS99)	23.45	23.45	23.45	23.45	23.45	21.96	21.96	21.96	21.96	21.96	21.96
WLAN5.2G Ch36 (802.11n-HT20)	16.57	16.57	16.57	16.57	16.57	16.39	16.39	16.39	16.39	16.39	16.39

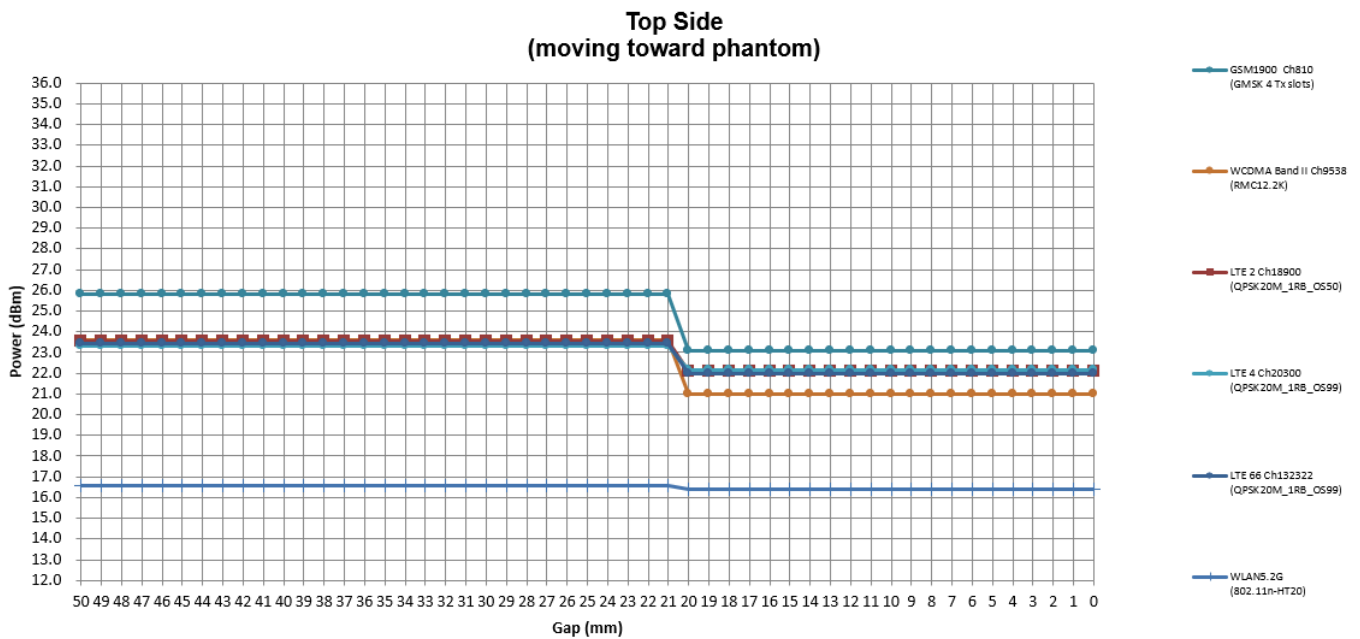

Output Power Verification in dBm for EUT Top Side (moving away phantom)											
Distance (mm)	18	19	20	21	22	23	24	25	26	27	28
GSM1900 Ch810 (GMSK 4Tx slots)	23.10	23.10	23.10	23.10	23.10	25.84	25.84	25.84	25.84	25.84	25.84
WCDMA B2 Ch9538 (RMC12.2K)	20.99	20.99	20.99	20.99	20.99	23.69	23.69	23.69	23.69	23.69	23.69
LTE 2 Ch18900 (QPSK20M_1RB_OS50)	22.10	22.10	22.10	22.10	22.10	23.55	23.55	23.55	23.55	23.55	23.55
LTE 4 Ch20300 (QPSK20M_1RB_OS99)	22.18	22.18	22.18	22.18	22.18	23.34	23.34	23.34	23.34	23.34	23.34
LTE 66 Ch132322 (QPSK20M_1RB_OS99)	21.96	21.96	21.96	21.96	21.96	23.45	23.45	23.45	23.45	23.45	23.45
WLAN5.2G Ch36 (802.11n-HT20)	16.39	16.39	16.39	16.39	16.39	16.57	16.57	16.57	16.57	16.57	16.57

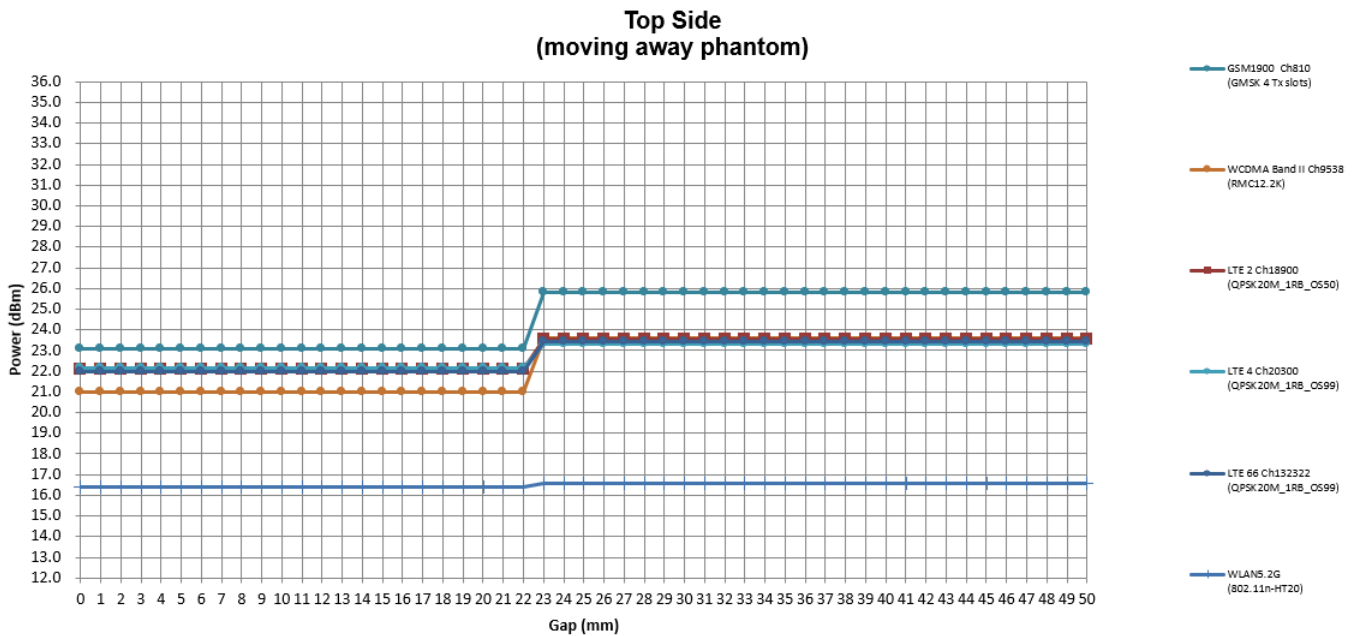

DSI-5

Output Power Verification in dBm for EUT Rear Face (moving toward phantom)											
Distance (mm)	28	27	26	25	24	23	22	21	20	19	18
GSM1900 Ch810 (GMSK 4Tx slots)	25.84	25.84	25.84	25.84	25.84	23.10	23.10	23.10	23.10	23.10	23.10
WCDMA B2 Ch9538 (RMC12.2K)	23.69	23.69	23.69	23.69	23.69	20.99	20.99	20.99	20.99	20.99	20.99
LTE 2 Ch18900 (QPSK20M_1RB_OS50)	23.55	23.55	23.55	23.55	23.55	21.72	21.72	21.72	21.72	21.72	21.72
LTE 4 Ch20300 (QPSK20M_1RB_OS99)	23.34	23.34	23.34	23.34	23.34	22.18	22.18	22.18	22.18	22.18	22.18
LTE 66 Ch132322 (QPSK20M_1RB_OS99)	23.45	23.45	23.45	23.45	23.45	21.96	21.96	21.96	21.96	21.96	21.96
WLAN2.4G Ch6 (802.11b 1Mbps)	18.62	18.62	18.62	18.62	18.62	16.95	16.95	16.95	16.95	16.95	16.95
WLAN5.2G Ch36 (802.11n-HT20)	16.57	16.57	16.57	16.57	16.57	13.04	13.04	13.04	13.04	13.04	13.04
WLAN5.3G Ch60 (802.11a-6Mbps)	16.54	16.54	16.54	16.54	16.54	11.21	11.21	11.21	11.21	11.21	11.21
WLAN5.5G Ch140 (802.11a-6Mbps)	17.01	17.01	17.01	17.01	17.01	15.54	15.54	15.54	15.54	15.54	15.54
WLAN5.8G Ch149 (802.11a-6Mbps)	16.96	16.96	16.96	16.96	16.96	16.39	16.39	16.39	16.39	16.39	16.39

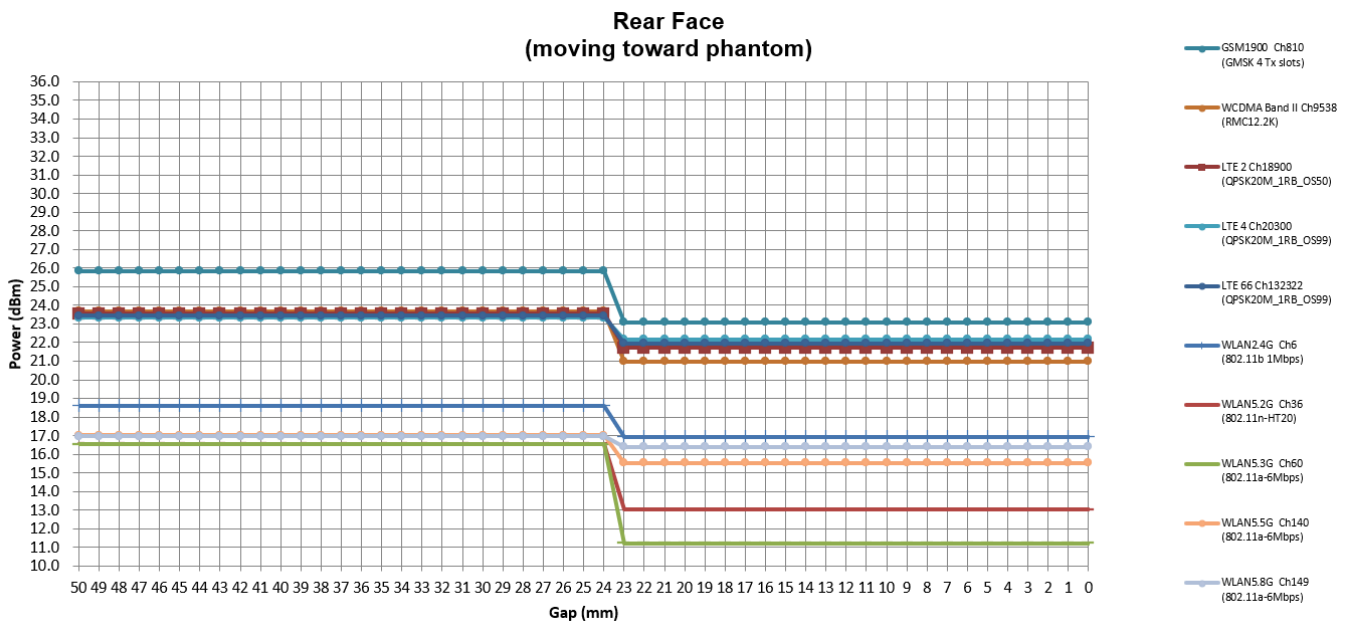

Output Power Verification in dBm for EUT Rear Face (moving away phantom)											
Distance (mm)	21	22	23	24	25	26	27	28	29	30	31
GSM1900 Ch810 (GMSK 4Tx slots)	23.10	23.10	23.10	23.10	23.10	25.84	25.84	25.84	25.84	25.84	25.84
WCDMA B2 Ch9538 (RMC12.2K)	20.99	20.99	20.99	20.99	20.99	23.69	23.69	23.69	23.69	23.69	23.69
LTE 2 Ch18900 (QPSK20M 1RB_OS50)	21.72	21.72	21.72	21.72	21.72	23.55	23.55	23.55	23.55	23.55	23.55
LTE 4 Ch20300 (QPSK20M 1RB_OS99)	22.18	22.18	22.18	22.18	22.18	23.34	23.34	23.34	23.34	23.34	23.34
LTE 66 Ch132322 (QPSK20M 1RB_OS99)	21.96	21.96	21.96	21.96	21.96	23.45	23.45	23.45	23.45	23.45	23.45
WLAN2.4G Ch6 (802.11b 1Mbps)	16.95	16.95	16.95	16.95	16.95	18.62	18.62	18.62	18.62	18.62	18.62
WLAN5.2G Ch36 (802.11n-HT20)	13.04	13.04	13.04	13.04	13.04	16.57	16.57	16.57	16.57	16.57	16.57
WLAN5.3G Ch60 (802.11a-6Mbps)	11.21	11.21	11.21	11.21	11.21	16.54	16.54	16.54	16.54	16.54	16.54
WLAN5.5G Ch140 (802.11a-6Mbps)	15.54	15.54	15.54	15.54	15.54	17.01	17.01	17.01	17.01	17.01	17.01
WLAN5.8G Ch149 (802.11a-6Mbps)	16.39	16.39	16.39	16.39	16.39	16.96	16.96	16.96	16.96	16.96	16.96

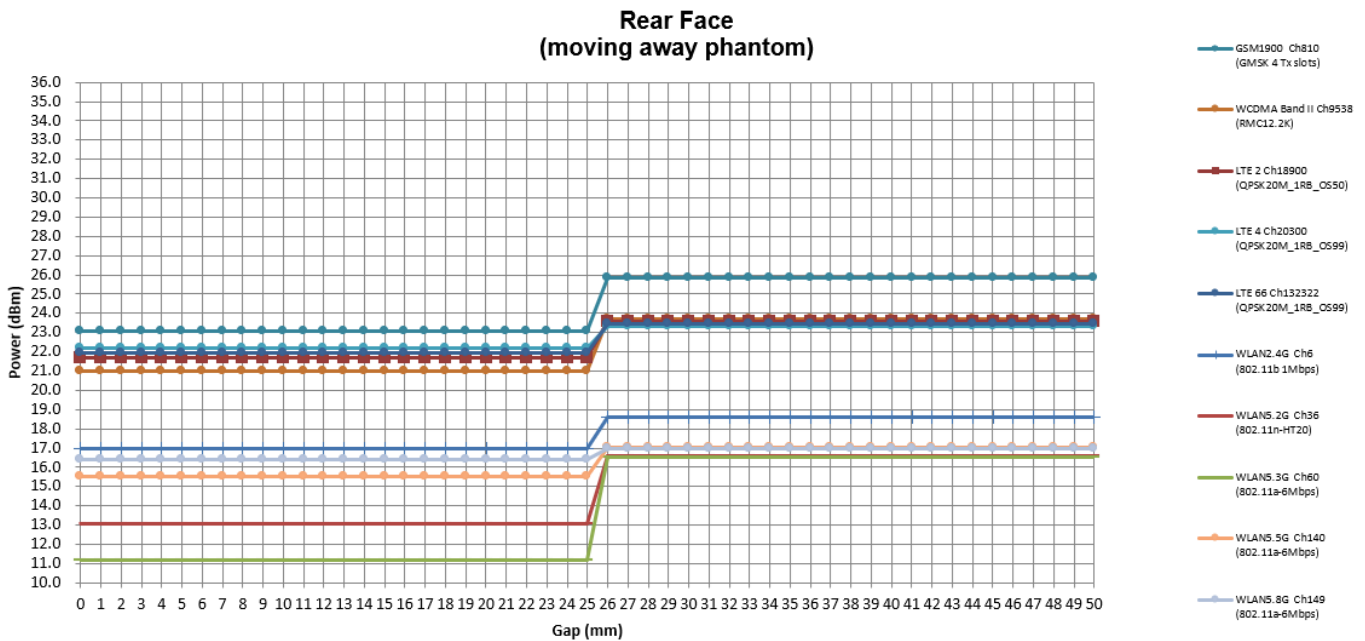

Output Power Verification in dBm for EUT Front Face (moving toward phantom)											
Distance (mm)	17	16	15	14	13	12	11	10	9	8	7
GSM1900 Ch810 (GMSK 4Tx slots)	25.84	25.84	25.84	25.84	25.84	23.10	23.10	23.10	23.10	23.10	23.10
WCDMA B2 Ch9538 (RMC12.2K)	23.69	23.69	23.69	23.69	23.69	20.99	20.99	20.99	20.99	20.99	20.99
LTE 2 Ch18900 (QPSK20M 1RB_OS50)	23.55	23.55	23.55	23.55	23.55	21.72	21.72	21.72	21.72	21.72	21.72
LTE 4 Ch20300 (QPSK20M 1RB_OS99)	23.34	23.34	23.34	23.34	23.34	22.18	22.18	22.18	22.18	22.18	22.18
LTE 66 Ch132322 (QPSK20M 1RB_OS99)	23.45	23.45	23.45	23.45	23.45	21.96	21.96	21.96	21.96	21.96	21.96
WLAN2.4G Ch6 (802.11b 1Mbps)	18.62	18.62	18.62	18.62	18.62	16.95	16.95	16.95	16.95	16.95	16.95
WLAN5.2G Ch36 (802.11n-HT20)	16.57	16.57	16.57	16.57	16.57	13.04	13.04	13.04	13.04	13.04	13.04
WLAN5.3G Ch60 (802.11a-6Mbps)	16.54	16.54	16.54	16.54	16.54	11.21	11.21	11.21	11.21	11.21	11.21
WLAN5.5G Ch140 (802.11a-6Mbps)	17.01	17.01	17.01	17.01	17.01	15.54	15.54	15.54	15.54	15.54	15.54
WLAN5.8G Ch149 (802.11a-6Mbps)	16.96	16.96	16.96	16.96	16.96	16.39	16.39	16.39	16.39	16.39	16.39

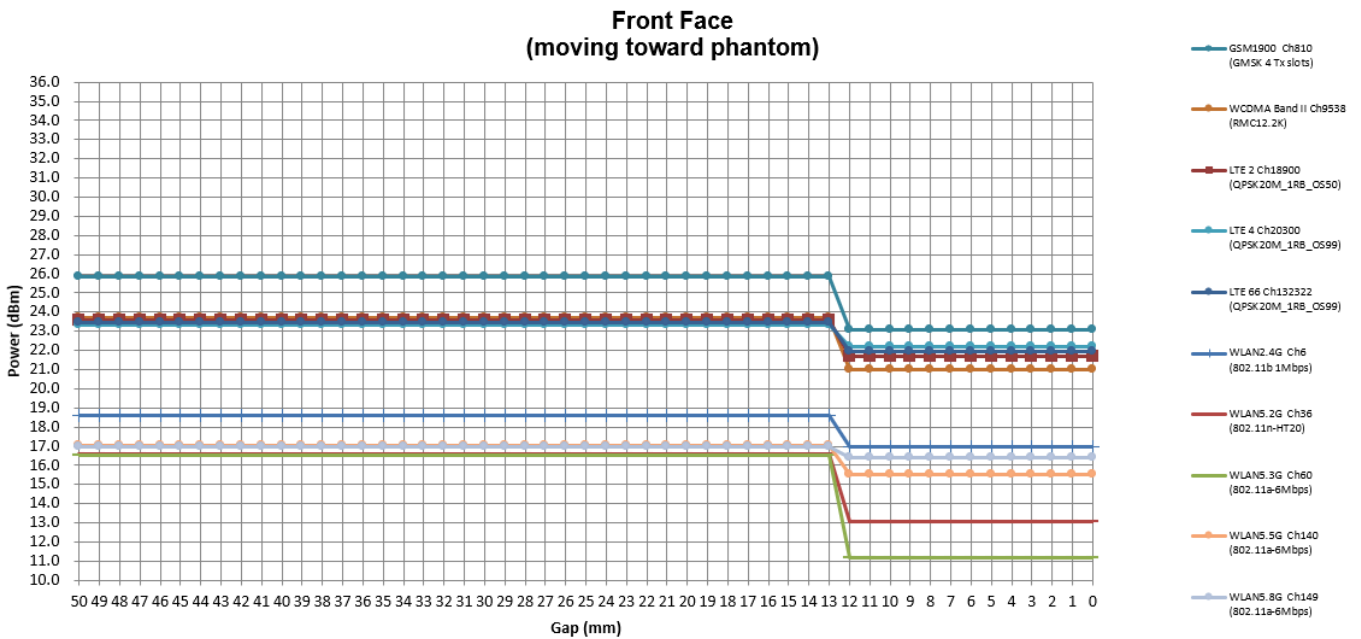

Output Power Verification in dBm for EUT Front Face (moving away phantom)											
Distance (mm)	10	11	12	13	14	15	16	17	18	19	20
GSM1900 Ch810 (GMSK 4Tx slots)	23.10	23.10	23.10	23.10	23.10	25.84	25.84	25.84	25.84	25.84	25.84
WCDMA B2 Ch9538 (RMC12.2K)	20.99	20.99	20.99	20.99	20.99	23.69	23.69	23.69	23.69	23.69	23.69
LTE 2 Ch18900 (QPSK20M 1RB_OS50)	21.72	21.72	21.72	21.72	21.72	23.55	23.55	23.55	23.55	23.55	23.55
LTE 4 Ch20300 (QPSK20M 1RB_OS99)	22.18	22.18	22.18	22.18	22.18	23.34	23.34	23.34	23.34	23.34	23.34
LTE 66 Ch132322 (QPSK20M 1RB_OS99)	21.96	21.96	21.96	21.96	21.96	23.45	23.45	23.45	23.45	23.45	23.45
WLAN2.4G Ch6 (802.11b 1Mbps)	16.95	16.95	16.95	16.95	16.95	18.62	18.62	18.62	18.62	18.62	18.62
WLAN5.2G Ch36 (802.11n-HT20)	13.04	13.04	13.04	13.04	13.04	16.57	16.57	16.57	16.57	16.57	16.57
WLAN5.3G Ch60 (802.11a-6Mbps)	11.21	11.21	11.21	11.21	11.21	16.54	16.54	16.54	16.54	16.54	16.54
WLAN5.5G Ch140 (802.11a-6Mbps)	15.54	15.54	15.54	15.54	15.54	17.01	17.01	17.01	17.01	17.01	17.01
WLAN5.8G Ch149 (802.11a-6Mbps)	16.39	16.39	16.39	16.39	16.39	16.96	16.96	16.96	16.96	16.96	16.96

Front Face
(moving away phantom)

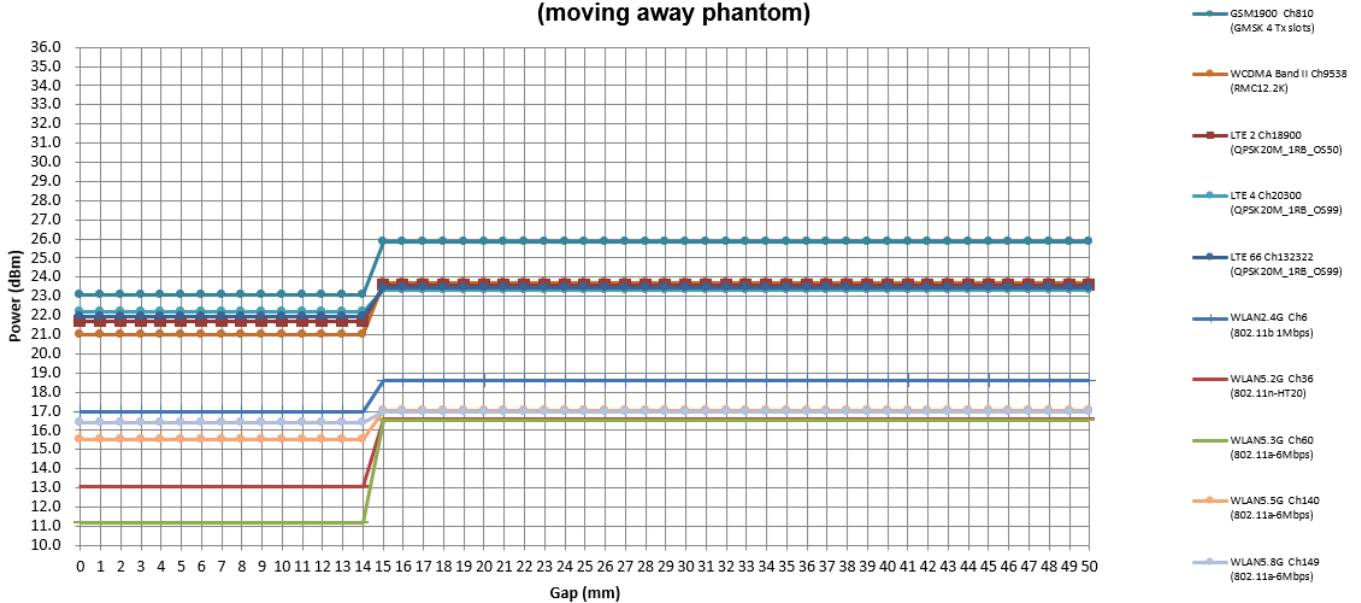

Output Power Verification in dBm for EUT Right Side (moving toward phantom)											
Distance (mm)	28	27	26	25	24	23	22	21	20	19	18
GSM1900 Ch810 (GMSK 4Tx slots)	25.84	25.84	25.84	25.84	25.84	23.10	23.10	23.10	23.10	23.10	23.10
WCDMA B2 Ch9538 (RMC12.2K)	23.69	23.69	23.69	23.69	23.69	20.99	20.99	20.99	20.99	20.99	20.99
LTE 2 Ch18900 (QPSK20M 1RB_OS50)	23.55	23.55	23.55	23.55	23.55	21.72	21.72	21.72	21.72	21.72	21.72
LTE 4 Ch20300 (QPSK20M 1RB_OS99)	23.34	23.34	23.34	23.34	23.34	22.18	22.18	22.18	22.18	22.18	22.18
LTE 66 Ch132322 (QPSK20M 1RB_OS99)	23.45	23.45	23.45	23.45	23.45	21.96	21.96	21.96	21.96	21.96	21.96
WLAN2.4G Ch6 (802.11b 1Mbps)	18.62	18.62	18.62	18.62	18.62	16.95	16.95	16.95	16.95	16.95	16.95
WLAN5.2G Ch36 (802.11n-HT20)	16.57	16.57	16.57	16.57	16.57	13.04	13.04	13.04	13.04	13.04	13.04
WLAN5.3G Ch60 (802.11a-6Mbps)	16.54	16.54	16.54	16.54	16.54	11.21	11.21	11.21	11.21	11.21	11.21
WLAN5.5G Ch140 (802.11a-6Mbps)	17.01	17.01	17.01	17.01	17.01	15.54	15.54	15.54	15.54	15.54	15.54
WLAN5.8G Ch149 (802.11a-6Mbps)	16.96	16.96	16.96	16.96	16.96	16.39	16.39	16.39	16.39	16.39	16.39

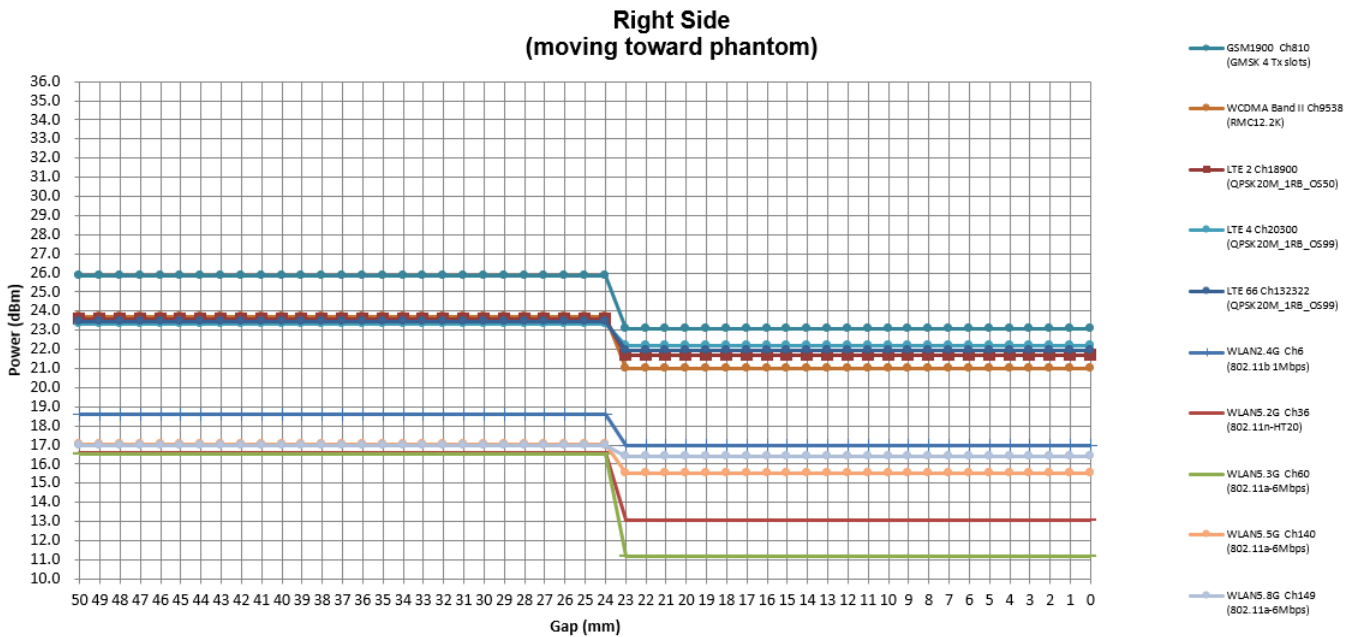

Output Power Verification in dBm for EUT Right Side (moving away phantom)											
Distance (mm)	21	22	23	24	25	26	27	28	29	30	31
GSM1900 Ch810 (GMSK 4Tx slots)	23.10	23.10	23.10	23.10	23.10	25.84	25.84	25.84	25.84	25.84	25.84
WCDMA B2 Ch9538 (RMC12.2K)	20.99	20.99	20.99	20.99	20.99	23.69	23.69	23.69	23.69	23.69	23.69
LTE 2 Ch18900 (QPSK20M 1RB_OS50)	21.72	21.72	21.72	21.72	21.72	23.55	23.55	23.55	23.55	23.55	23.55
LTE 4 Ch20300 (QPSK20M 1RB_OS99)	22.18	22.18	22.18	22.18	22.18	23.34	23.34	23.34	23.34	23.34	23.34
LTE 66 Ch132322 (QPSK20M 1RB_OS99)	21.96	21.96	21.96	21.96	21.96	23.45	23.45	23.45	23.45	23.45	23.45
WLAN2.4G Ch6 (802.11b 1Mbps)	16.95	16.95	16.95	16.95	16.95	18.62	18.62	18.62	18.62	18.62	18.62
WLAN5.2G Ch36 (802.11n-HT20)	13.04	13.04	13.04	13.04	13.04	16.57	16.57	16.57	16.57	16.57	16.57
WLAN5.3G Ch60 (802.11a-6Mbps)	11.21	11.21	11.21	11.21	11.21	16.54	16.54	16.54	16.54	16.54	16.54
WLAN5.5G Ch140 (802.11a-6Mbps)	15.54	15.54	15.54	15.54	15.54	17.01	17.01	17.01	17.01	17.01	17.01
WLAN5.8G Ch149 (802.11a-6Mbps)	16.39	16.39	16.39	16.39	16.39	16.96	16.96	16.96	16.96	16.96	16.96

Right Side
(moving away phantom)

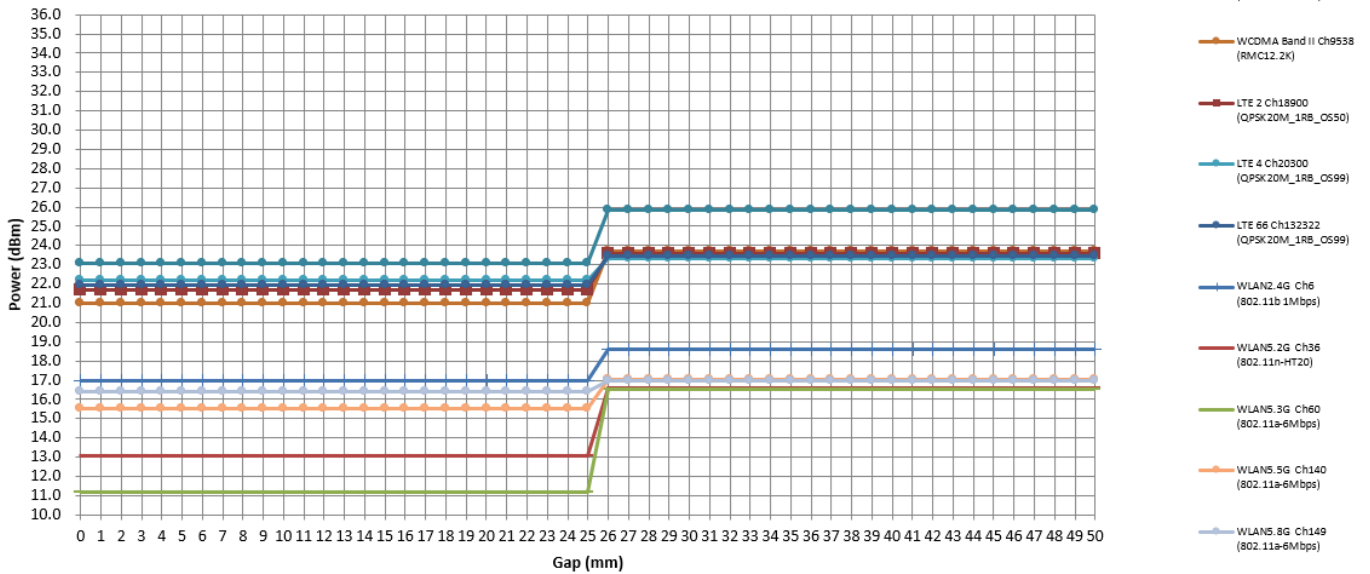

Output Power Verification in dBm for EUT Top Side (moving toward phantom)											
Distance (mm)	25	24	23	22	21	20	19	18	17	16	15
GSM1900 Ch810 (GMSK 4Tx slots)	25.84	25.84	25.84	25.84	25.84	23.10	23.10	23.10	23.10	23.10	23.10
WCDMA B2 Ch9538 (RMC12.2K)	23.69	23.69	23.69	23.69	23.69	20.99	20.99	20.99	20.99	20.99	20.99
LTE 2 Ch18900 (QPSK20M 1RB_OS50)	23.55	23.55	23.55	23.55	23.55	21.72	21.72	21.72	21.72	21.72	21.72
LTE 4 Ch20300 (QPSK20M 1RB_OS99)	23.34	23.34	23.34	23.34	23.34	22.18	22.18	22.18	22.18	22.18	22.18
LTE 66 Ch132322 (QPSK20M 1RB_OS99)	23.45	23.45	23.45	23.45	23.45	21.96	21.96	21.96	21.96	21.96	21.96
WLAN2.4G Ch6 (802.11b 1Mbps)	18.62	18.62	18.62	18.62	18.62	16.95	16.95	16.95	16.95	16.95	16.95
WLAN5.2G Ch36 (802.11n-HT20)	16.57	16.57	16.57	16.57	16.57	13.04	13.04	13.04	13.04	13.04	13.04
WLAN5.3G Ch60 (802.11a-6Mbps)	16.54	16.54	16.54	16.54	16.54	11.21	11.21	11.21	11.21	11.21	11.21
WLAN5.5G Ch140 (802.11a-6Mbps)	17.01	17.01	17.01	17.01	17.01	15.54	15.54	15.54	15.54	15.54	15.54
WLAN5.8G Ch149 (802.11a-6Mbps)	16.96	16.96	16.96	16.96	16.96	16.39	16.39	16.39	16.39	16.39	16.39

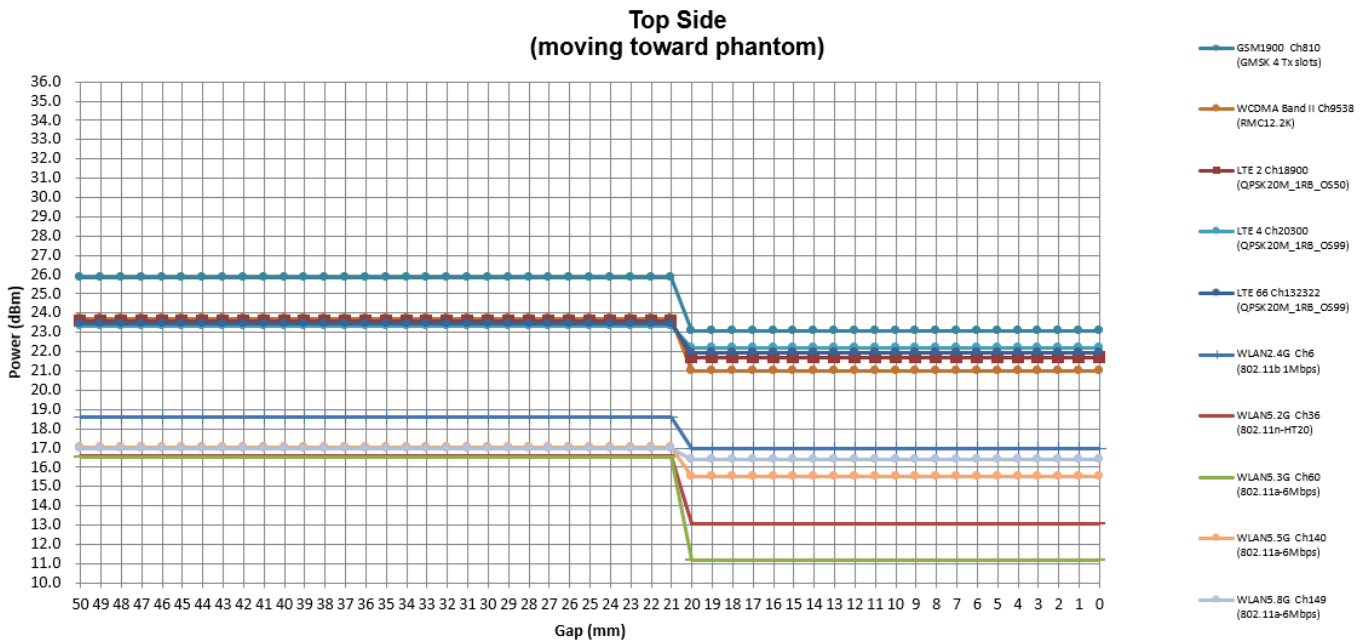

Output Power Verification in dBm for EUT Top Side (moving away phantom)											
Distance (mm)	18	19	20	21	22	23	24	25	26	27	28
GSM1900 Ch810 (GMSK 4Tx slots)	23.10	23.10	23.10	23.10	23.10	25.84	25.84	25.84	25.84	25.84	25.84
WCDMA B2 Ch9538 (RMC12.2K)	20.99	20.99	20.99	20.99	20.99	23.69	23.69	23.69	23.69	23.69	23.69
LTE 2 Ch18900 (QPSK20M_1RB_OS50)	21.72	21.72	21.72	21.72	21.72	23.55	23.55	23.55	23.55	23.55	23.55
LTE 4 Ch20300 (QPSK20M_1RB_OS99)	22.18	22.18	22.18	22.18	22.18	23.34	23.34	23.34	23.34	23.34	23.34
LTE 66 Ch132322 (QPSK20M_1RB_OS99)	21.96	21.96	21.96	21.96	21.96	23.45	23.45	23.45	23.45	23.45	23.45
WLAN2.4G Ch6 (802.11b 1Mbps)	16.95	16.95	16.95	16.95	16.95	18.62	18.62	18.62	18.62	18.62	18.62
WLAN5.2G Ch36 (802.11n-HT20)	13.04	13.04	13.04	13.04	13.04	16.57	16.57	16.57	16.57	16.57	16.57
WLAN5.3G Ch60 (802.11a-6Mbps)	11.21	11.21	11.21	11.21	11.21	16.54	16.54	16.54	16.54	16.54	16.54
WLAN5.5G Ch140 (802.11a-6Mbps)	15.54	15.54	15.54	15.54	15.54	17.01	17.01	17.01	17.01	17.01	17.01
WLAN5.8G Ch149 (802.11a-6Mbps)	16.39	16.39	16.39	16.39	16.39	16.96	16.96	16.96	16.96	16.96	16.96

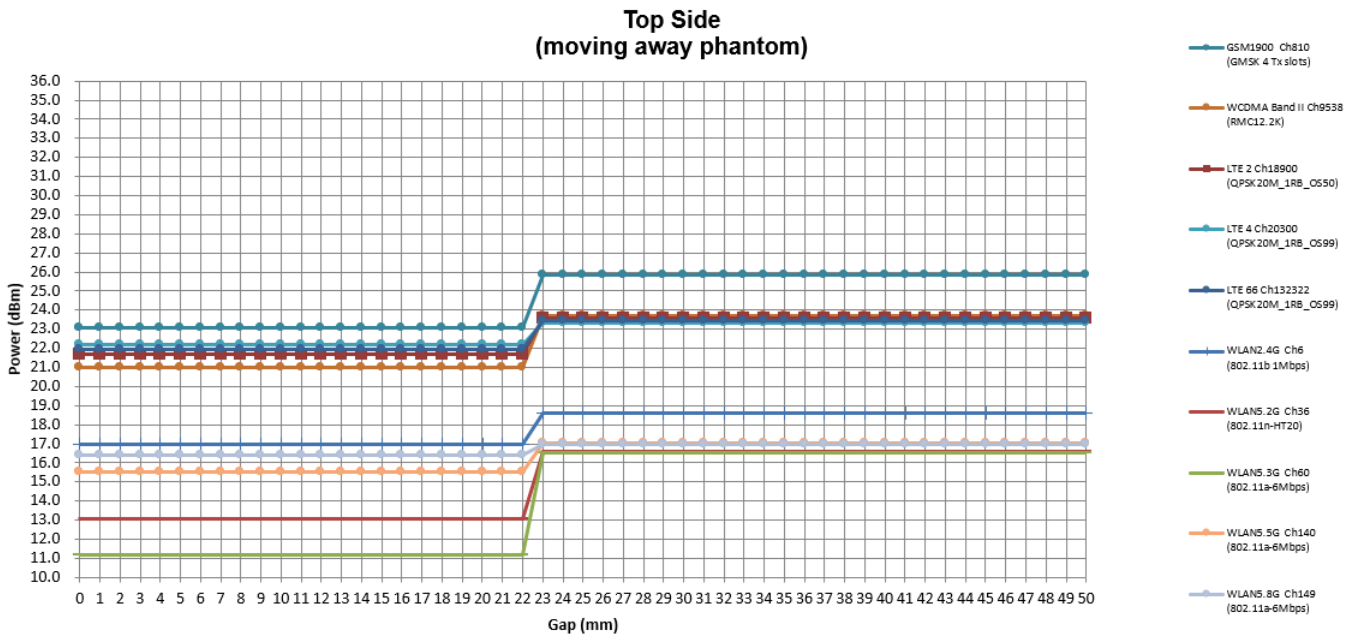

< Proximity Sensor Coverage >

In KDB 616217 section 6.3, if a sensor is spatially offset from the antenna(s), it is necessary to verify sensor triggering for conditions where the antenna is next to the user but the sensor is laterally further away to ensure sensor coverage is sufficient for reducing the power to maintain compliance. For p-sensor coverage testing, the device is moved and “along the direction of maximum antenna and sensor offset”.

However, this device uses a capacitive proximity sensor that is same metallic component as the transmitting antenna to facilitate triggering in any condition the user may use the device in proximity of the antenna in the device. Therefore, no further sensor coverage assessments were required.

<Proximity Sensor Tilt Angle Influences>

The proximity sensor tilt angle influence was determined per KDB 616217 for applicable edge. Summary for proximity sensor tilt angle influence is shown in below.

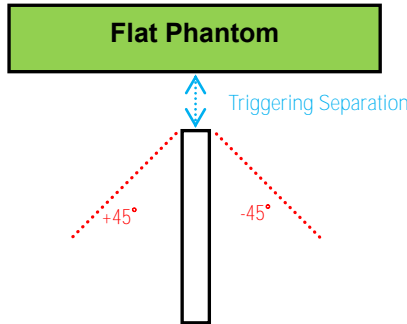

Orientation	Separation Distance (mm)	Tilt Angle										
		-45°	-40°	-30°	-20°	-10°	0°	10°	20°	30°	40°	45°
Right Side	23	On	On	On	On	On	On	On	On	On	On	On
Top Side	20	On	On	On	On	On	On	On	On	On	On	On

<Summary for Proximity Sensor Triggering Test>

According to the procedures noticed in KDB 616217 D04,

The WWAN for proximity sensor triggering distance is 12 mm for EUT Front Face, 23 mm for Rear Face, 20 mm for Top Side, 23 mm for Right Side. The separation distance of 23 mm determined by the smallest triggering distance on Right Side is used to access the tilt angle influence and the sensor does not release during ±45 degree. Therefore, the smallest separation distance for tilt angle influence is 23 mm for the Right Side. The conservation triggering distances based on the separation distance for the sensor trigger / not triggered as EUT with power reduction at 0 mm, and EUT without power reduction at 11 mm for EUT Front Face, 22 mm for EUT Rear Face and Right Side, 19 mm for Top Side were used to test SAR.

The power reduction is depends on the proximity sensor input. For a steady SAR test, the power reduction was enabled or disabled manually by engineering software during SAR testing.

WWAN Proximity Sensor Trigger Distance (mm)				
Position	Front Face	Rear Face	Right Side	Top Side
Minimum	12	23	23	20

<Considerations Related to GSM / GPRS / EDGE for Setup and Testing>

The maximum multi-slot capability supported by this device is as below.

1. This EUT is class B device
2. This EUT supports GPRS multi-slot class 12 (max. uplink: 4, max. downlink: 4, total timeslots: 5)
3. This EUT supports EDGE multi-slot class 12 (max. uplink: 4, max. downlink: 4, total timeslots: 5)

For GSM850 frequency band, the power control level is set to 5 for GSM mode and GPRS (GMSK: CS1), and set to 8 for EDGE (GMSK: MCS1, 8PSK: MCS9). For GSM1900 frequency band, the power control level is set to 0 for GSM mode and GPRS (GMSK: CS1), and set to 2 for EDGE (GMSK: MCS1, 8PSK: MCS9).

SAR test reduction for GPRS and EDGE modes is determined by the source-based time-averaged output power specified for production units, including tune-up tolerance. The data mode with highest specified time-averaged output power should be tested for SAR compliance in the applicable exposure conditions. For modes with the same specified maximum output power and tolerance, the higher number time-slot configuration should be tested.

The frame-averaged power is linearly proportion to the slot number configured and it is linearly scaled the maximum burst-averaged power based on time slots. The calculated method is shown as below:

Frame-averaged power = 10 x log (Burst-averaged power mW x Slot used / 8)

<Considerations Related to WCDMA for Setup and Testing>

WCDMA Handsets Head SAR

SAR for next to the ear head exposure is measured using a 12.2 kbps RMC with TPC bits configured to all "1's". The 3G SAR test reduction procedure is applied to AMR configurations with 12.2 kbps RMC as the primary mode.

WCDMA Handsets Body-worn SAR

SAR for body-worn configurations is measured using a 12.2 kbps RMC with TPC bits configured to all "1's". The 3G SAR test reduction procedure is applied to other spreading codes and multiple DPDCH_n configurations supported by the handset with 12.2 kbps RMC as the primary mode.

Handsets with Release 5 HSDPA

The 3G SAR test reduction procedure is applied to HSDPA body-worn configurations with 12.2 kbps RMC as the primary mode. Otherwise, SAR is measured for HSDPA using the HSDPA body SAR procedures in the "Release 5 HSDPA Data Devices", for the highest reported SAR body-worn exposure configuration in 12.2 kbps RMC. Handsets with both HSDPA and HSUPA are tested according to Release 6 HSPA test procedures.

Handsets with Release 6 HSUPA

The 3G SAR test reduction procedure is applied to HSPA (HSUPA/HSDPA with RMC) body-worn configurations with 12.2 kbps RMC as the primary mode. Otherwise, SAR is measured for HSPA using the HSPA body SAR procedures in the "Release 6 HSPA Data Devices", for the highest reported body-worn exposure SAR configuration in 12.2 kbps RMC. When VOIP is applicable for next to the ear head exposure in HSPA, the 3G SAR test reduction procedure is applied to HSPA with 12.2 kbps RMC as the primary mode; otherwise, the same HSPA configuration used for body-worn measurements is tested for next to the ear head exposure.

Release 5 HSDPA Data Devices

The 3G SAR test reduction procedure is applied to body SAR with 12.2 kbps RMC as the primary mode. Otherwise, body SAR for HSDPA is measured using an FRC with H-Set 1 in Sub-test 1 and a 12.2 kbps RMC configured in Test Loop Mode 1, for the highest reported SAR configuration in 12.2 kbps RMC without HSDPA. HSDPA is configured according to the applicable UE category of a test device. The number of HS-DSCH / HS-PDSCHs, HARQ processes, minimum inter-TTI interval, transport block sizes and RV coding sequence are defined by the H-set. To maintain a consistent test configuration and stable transmission conditions, QPSK is used in the H-set for SAR testing. HS-DPCCH should be configured with a CQI feedback cycle of 4 ms and a CQI repetition factor of 2 to maintain a constant rate of active CQI slots. DPCCH and DPDCH gain factors (β_c , β_d), and HS-DPCCH power offset parameters (Δ_{ACK} , Δ_{NACK} , Δ_{CQI}) are set according to values indicated in below. The CQI value is determined by the UE category, transport block size, number of HS-PDSCHs and modulation used in the H-set.

Sub-test	β_c	β_d	β_d (SF)	β_c / β_d	$\beta_{hs}^{(1)}$	CM (dB) ⁽²⁾	MPR
1	2 / 15	15 / 15	64	2 / 15	4 / 15	0.0	0
2	12 / 15 ⁽³⁾	15 / 15 ⁽³⁾	64	12 / 15 ⁽³⁾	24 / 15	1.0	0
3	15 / 15	8 / 15	64	15 / 8	30 / 15	1.5	0.5
4	15 / 15	4 / 15	64	15 / 4	30 / 15	1.5	0.5

Note 1: Δ_{ACK} , Δ_{NACK} and $\Delta_{CQI} = 8 \Leftrightarrow A_{hs} = \beta_{hs} / \beta_c = 30 / 15 \Leftrightarrow \beta_{hs} = 30 / 15 * \beta_c$.

Note 2: CM = 1 for $\beta_c / \beta_d = 12 / 15$, $\beta_{hs} / \beta_c = 24 / 15$.

Note 3: For subtest 2 the β_c / β_d ratio of 12 / 15 for the TFC during the measurement period (TF1, TF0) is achieved by setting the signaled gain factors for the reference TFC (TF1, TF1) to $\beta_c = 11 / 15$ and $\beta_d = 15 / 15$.

Release 6 HSUPA Data Devices

The 3G SAR test reduction procedure is applied to body SAR with 12.2 kbps RMC as the primary mode. Otherwise, body SAR for HSPA is measured with E-DCH Sub-test 5, using H-Set 1 and QPSK for FRC and a 12.2 kbps RMC configured in Test Loop Mode 1 and power control algorithm 2, according to the highest reported body SAR configuration in 12.2 kbps RMC without HSPA. When VOIP applies to head exposure, the 3G SAR test reduction procedure is applied with 12.2 kbps RMC as the primary mode. Otherwise, the same HSPA configuration used for body SAR measurements are applied to head exposure testing. Due to inner loop power control requirements in HSPA, a communication test set is required for output power and SAR tests. The 12.2 kbps RMC, FRC H-set 1 and E-DCH configurations for HSPA are configured according to the β values indicated in below.

Sub-test	β_c	β_d	β_d (SF)	β_c / β_d	$\beta_{hs}^{(1)}$	β_{ac}	β_{ed}	β_{ed} (SF)	β_{ed} (codes)	CM ⁽²⁾ (dB)	MPR (dB)	AG ⁽⁴⁾ Index	E-TFCI
1	11 / 15 ⁽³⁾	15 / 15 ⁽³⁾	64	11 / 15 ⁽³⁾	22 / 15	209 / 225	1039 / 225	4	1	1.0	0.0	20	75
2	6 / 15	15 / 15	64	6 / 15	12 / 15	12 / 15	94 / 75	4	1	3.0	2.0	12	67
3	15 / 15	9 / 15	64	15 / 9	30 / 15	30 / 15	β_{ed1} : 47/15 β_{ed2} : 47/15	4	2	2.0	1.0	15	92
4	2 / 15	15 / 15	64	2 / 15	4 / 15	2 / 15	56 / 75	4	1	3.0	2.0	17	71
5	15 / 15 ⁽⁴⁾	15 / 15 ⁽⁴⁾	64	15 / 15 ⁽⁴⁾	30 / 15	24 / 15	134 / 15	4	1	1.0	0.0	21	81

Note 1: Δ_{ACK} , Δ_{NACK} and $\Delta_{COI} = 8 \Leftrightarrow A_{hs} = \beta_{hs} / \beta_c = 30 / 15 \Leftrightarrow \beta_{hs} = 30 / 15 * \beta_c$
 Note 2: CM = 1 for $\beta_c / \beta_d = 12 / 15$, $\beta_{hs} / \beta_c = 24 / 15$. For all other combinations of DPDCH, DPCCH, HS-DPCCH, E-DPDCH and E-DPCCH the MPR is based on the relative CM difference.
 Note 3: For subtest 1 the β_c / β_d ratio of 11 / 15 for the TFC during the measurement period (TF1, TF0) is achieved by setting the signaled gain factors for the reference TFC (TF1, TF1) to $\beta_c = 10 / 15$ and $\beta_d = 15 / 15$.
 Note 4: For subtest 5 the β_c / β_d ratio of 15 / 15 for the TFC during the measurement period (TF1, TF0) is achieved by setting the signaled gain factors for the reference TFC (TF1, TF1) to $\beta_c = 14 / 15$ and $\beta_d = 15 / 15$.
 Note 5: Testing UE using E-DPDCH Physical Layer category 1 Sub-test 3 is not required according to TS 25.306 Table 5.1g.
 Note 6: β_{ed} cannot be set directly; it is set by Absolute Grant Value.

DC-HSDPA SAR Guidance

The 3G SAR test reduction procedure is applied to DC-HSDPA with 12.2 kbps RMC as the primary mode. Otherwise, when SAR is required for Rel. 5 HSDPA, SAR is required for Rel. 8 DC-HSDPA. Power is measured for DC-HSDPA according to the H-Set 12, FRC configuration in Table C.8.1.12 of 3GPP TS 34.121-1 to determine SAR test reduction. A primary and a secondary serving HS-DSCH Cell are required to perform the power measurement and for the results to be acceptable.

<Considerations Related to LTE for Setup and Testing>

This device contains LTE transmitter which follows 3GPP standards, supports both QPSK 16QAM and 64QAM modulations, and supported LTE band and channel bandwidth is listed in below. The output power was tested per 3GPP TS 36.521-1 maximum transmit procedures for both QPSK 16QAM and 64QAM modulation. The results please refer to section 4.6 of this report.

EUT Supported LTE Band and Channel Bandwidth						
LTE Band	BW 1.4 MHz	BW 3 MHz	BW 5 MHz	BW 10 MHz	BW 15 MHz	BW 20 MHz
2	V	V	V	V	V	V
4	V	V	V	V	V	V
5	V	V	V	V		
12	V	V	V	V		
13			V	V		
66	V	V	V	V	V	V

The LTE maximum power reduction (MPR) in accordance with 3GPP TS 36.101 is active all times during LTE operation. The allowed MPR for the maximum output power is specified in below.

Modulation	Channel Bandwidth / RB Configurations						LTE MPR Setting (dB)
	BW 1.4 MHz	BW 3 MHz	BW 5 MHz	BW 10 MHz	BW 15 MHz	BW 20 MHz	
QPSK	> 5	> 4	> 8	> 12	> 16	> 18	1
16QAM	<= 5	<= 4	<= 8	<= 12	<= 16	<= 18	1
16QAM	> 5	> 4	> 8	> 12	> 16	> 18	2
64QAM	<= 5	<= 4	<= 8	<= 12	<= 16	<= 18	2
64QAM	> 5	> 4	> 8	> 12	> 16	> 18	3

Note: MPR is according to the standard and implemented in the circuit (mandatory).

In addition, the device is compliant with additional maximum power reduction (A-MPR) requirements defined in 3GPP TS 36.101 section 6.2.4 that was disabled for all FCC compliance testing.

During LTE SAR testing, the related parameters of operating band, channel bandwidth, uplink channel number, modulation type, and RB was set in base station simulator. When the EUT has registered and communicated to base station simulator, the simulator set to make EUT transmitting the maximum radiated power.

<Considerations Related to WLAN for Setup and Testing>

In general, various vendor specific external test software and chipset based internal test modes are typically used for SAR measurement. These chipset based test mode utilities are generally hardware and manufacturer dependent, and often include substantial flexibility to reconfigure or reprogram a device. A Wi-Fi device must be configured to transmit continuously at the required data rate, channel bandwidth and signal modulation, using the highest transmission duty factor supported by the test mode tools for SAR measurement. The test frequencies established using test mode must correspond to the actual channel frequencies. When 802.11 frame gaps are accounted for in the transmission, a maximum transmission duty factor of 92 - 96% is typically achievable in most test mode configurations. A minimum transmission duty factor of 85% is required to avoid certain hardware and device implementation issues related to wide range SAR scaling. In addition, a periodic transmission duty factor is required for current generation SAR systems to measure SAR correctly. The reported SAR must be scaled to 100% transmission duty factor to determine compliance at the maximum tune-up tolerance limit.

According to KDB 248227 D01, this device has installed WLAN engineering testing software which can provide continuous transmitting RF signal. During WLAN SAR testing, this device was operated to transmit continuously at the maximum transmission duty with specified transmission mode, operating frequency, lowest data rate, and maximum output power.

Initial Test Configuration

An initial test configuration is determined for OFDM transmission modes in 2.4 GHz and 5 GHz bands according to the channel bandwidth, modulation and data rate combination(s) with the highest maximum output power specified for production units in each standalone and aggregated frequency band. When the same maximum power is specified for multiple transmission modes in a frequency band, the largest channel bandwidth, lowest order modulation, lowest data rate and lowest order 802.11a/g/n/ac mode is used for SAR measurement, on the highest

measured output power channel in the initial test configuration, for each frequency band.

Subsequent Test Configuration

SAR measurement requirements for the remaining 802.11 transmission mode configurations that have not been tested in the initial test configuration are determined separately for each standalone and aggregated frequency band, in each exposure condition, according to the maximum output power specified for production units. Additional power measurements may be required to determine if SAR measurements are required for subsequent highest output power channels in a subsequent test configuration. When the highest reported SAR for the initial test configuration according to the initial test position or fixed exposure position requirements, is adjusted by the ratio of the subsequent test configuration to initial test configuration specified maximum output power and the adjusted SAR is ≤ 1.2 W/kg, SAR is not required for that subsequent test configuration.

SAR Test Configuration and Channel Selection

When multiple channel bandwidth configurations in a frequency band have the same specified maximum output power, the initial test configuration is using largest channel bandwidth, lowest order modulation, lowest data rate, and lowest order 802.11 mode (i.e., 802.11a is chosen over 802.11n then 802.11ac or 802.11g is chosen over 802.11n). After an initial test configuration is determined, if multiple test channels have the same measured maximum output power, the channel chosen for SAR measurement is determined according to the following.

- 1) The channel closest to mid-band frequency is selected for SAR measurement.
- 2) For channels with equal separation from mid-band frequency; for example, high and low channels or two mid-band channels, the higher frequency (number) channel is selected for SAR measurement.

Test Reduction for U-NII-1 (5.2 GHz) and U-NII-2A (5.3 GHz) Bands

For devices that operate in both U-NII bands using the same transmitter and antenna(s), SAR test reduction is determined according to the following.

- 1) When the same maximum output power is specified for both bands, begin SAR measurement in U-NII-2A band by applying the OFDM SAR requirements. If the highest reported SAR for a test configuration is ≤ 1.2 W/kg, SAR is not required for U-NII-1 band for that configuration (802.11 mode and exposure condition).
- 2) When different maximum output power is specified for the bands, begin SAR measurement in the band with higher specified maximum output power. The highest reported SAR for the tested configuration is adjusted by the ratio of lower to higher specified maximum output power for the two bands. When the adjusted SAR is ≤ 1.2 W/kg, SAR is not required for the band with lower maximum output power in that test configuration.

<Considerations Related to Bluetooth for Setup and Testing>

This device has installed Bluetooth engineering testing software which can provide continuous transmitting RF signal. During Bluetooth SAR testing, this device was operated to transmit continuously at the maximum transmission duty with specified transmission mode, operating frequency, lowest data rate, and maximum output power

<BT Duty Cycle of Test Signal>

BT_GFSK: Duty cycle = 2.895 / 3.750 = 0.722

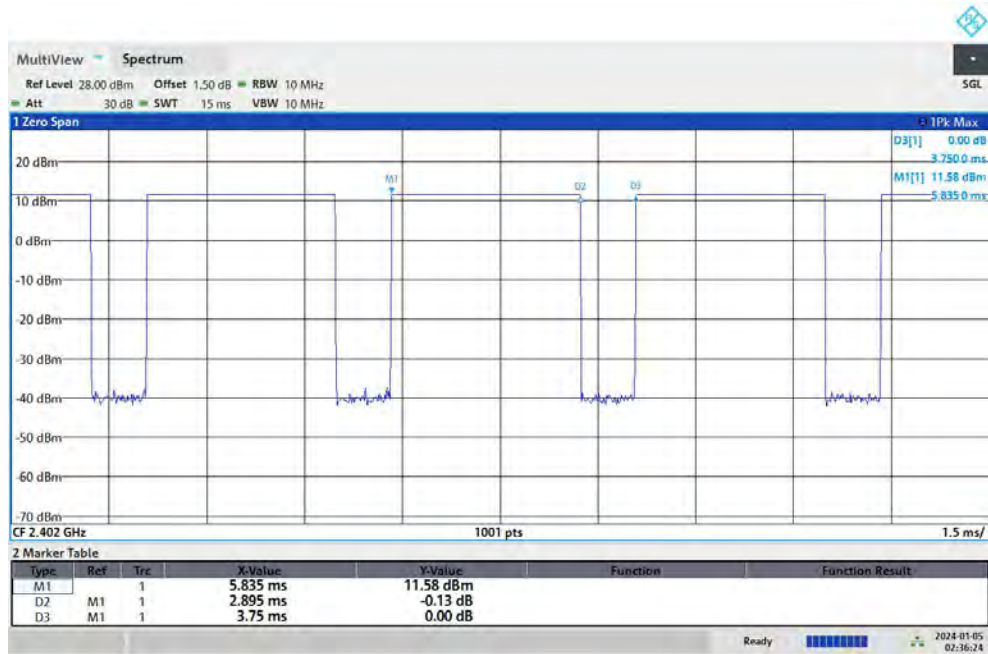

02:36:25 AM 01/05/2024

4.2 EUT Testing Position

According to KDB 648474 D04, handsets are tested for SAR compliance in head, body-worn accessory and other use configurations described in the following subsections.

4.2.1 Head Exposure Conditions

Head exposure is limited to next to the ear voice mode operations. Head SAR compliance is tested according to the test positions defined in IEEE Std 1528-2013 using the SAM phantom illustrated as below.

1. Define two imaginary lines on the handset

- (a) The vertical centerline passes through two points on the front side of the handset - the midpoint of the width w_t of the handset at the level of the acoustic output, and the midpoint of the width w_b of the bottom of the handset.
- (b) The horizontal line is perpendicular to the vertical centerline and passes through the center of the acoustic output. The horizontal line is also tangential to the face of the handset at point A.
- (c) The two lines intersect at point A. Note that for many handsets, point A coincides with the center of the acoustic output; however, the acoustic output may be located elsewhere on the horizontal line. Also note that the vertical centerline is not necessarily parallel to the front face of the handset, especially for clamshell handsets, handsets with flip covers, and other irregularly shaped handsets.

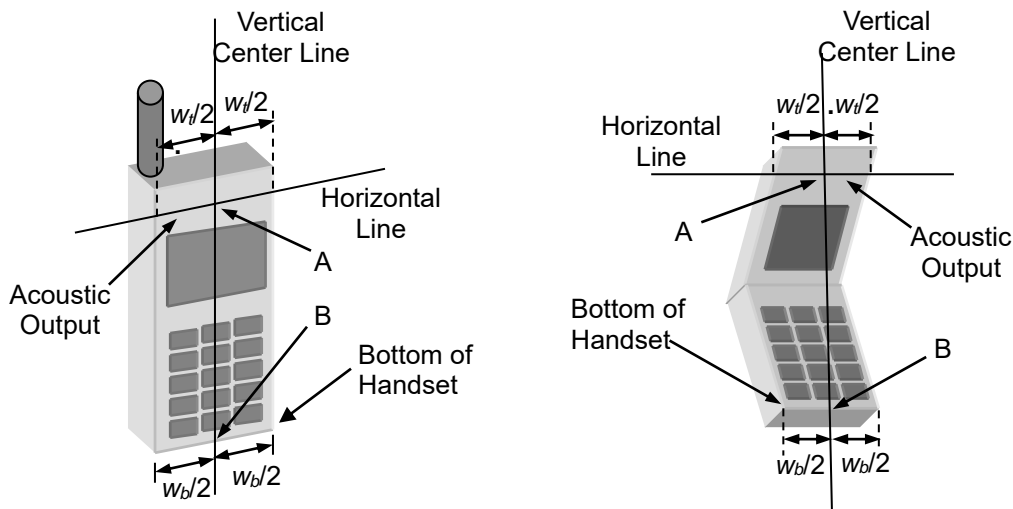

Fig-4.1 Illustration for Handset Vertical and Horizontal Reference Lines

2. Cheek Position

- (a) To position the device with the vertical center line of the body of the device and the horizontal line crossing the center piece in a plane parallel to the sagittal plane of the phantom. While maintaining the device in this plane, align the vertical center line with the reference plane containing the three ear and mouth reference point (M: Mouth, RE: Right Ear, and LE: Left Ear) and align the center of the ear piece with the line RE-LE.
- (b) To move the device towards the phantom with the ear piece aligned with the line LE-RE until the phone touched the ear. While maintaining the device in the reference plane and maintaining the phone contact with the ear, move the bottom of the phone until any point on the front side is in contact with the cheek of the phantom or until

contact with the ear is lost (see Fig-4.2).

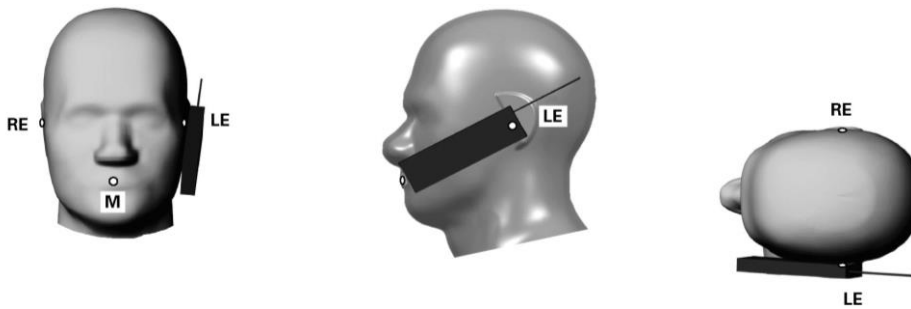

Fig-4.2 Illustration for Cheek Position

3. Tilted Position

(a) To position the device in the "cheek" position described above.

(b) While maintaining the device the reference plane described above and pivoting against the ear, moves it outward away from the mouth by an angle of 15 degrees or until contact with the ear is lost (see Fig-4.3).

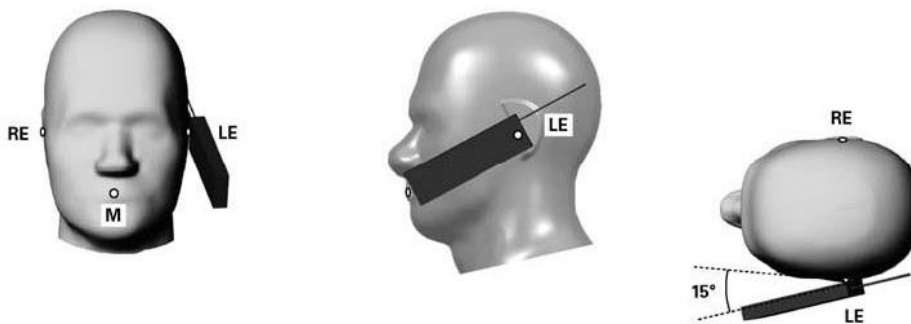

Fig-4.3 Illustration for Tilted Position

4.2.2 Body-worn Accessory Exposure Conditions

Body-worn accessory exposure is typically related to voice mode operations when handsets are carried in body-worn accessories. The body-worn accessory procedures in KDB 447498 D01 are used to test for body-worn accessory SAR compliance, without a headset connected to it. This enables the test results for such configuration to be compatible with that required for hotspot mode when the body-worn accessory test separation distance is greater than or equal to that required for hotspot mode. When the reported SAR for a body-worn accessory, measured without a headset connected to the handset, is > 1.2 W/kg, the highest reported SAR configuration for that wireless mode and frequency band should be repeated for that body-worn accessory with a headset attached to the handset.

Body-worn accessories that do not contain metallic or conductive components may be tested according to worst-case exposure configurations, typically according to the smallest test separation distance required for the group of body-worn accessories with similar operating and exposure characteristics. All body-worn accessories containing metallic components are tested in conjunction with the host device.

Body-worn accessory SAR compliance is based on a single minimum test separation distance for all wireless and operating modes applicable to each body-worn accessory used by the host, and according to the relevant voice and/or data mode transmissions and operations. If a body-worn accessory supports voice only operations in its normal and expected use conditions, testing of data mode for body-worn compliance is not required.

A conservative minimum test separation distance for supporting off-the-shelf body-worn accessories that may be acquired by users of consumer handsets is used to test for body-worn accessory SAR compliance. This distance is determined by the handset manufacturer, according to the requirements of Supplement C 01-01. Devices that are designed to operate on the body of users using lanyards and straps, or without requiring additional body-worn accessories, will be tested using a conservative minimum test separation distance ≤ 5 mm to support compliance.

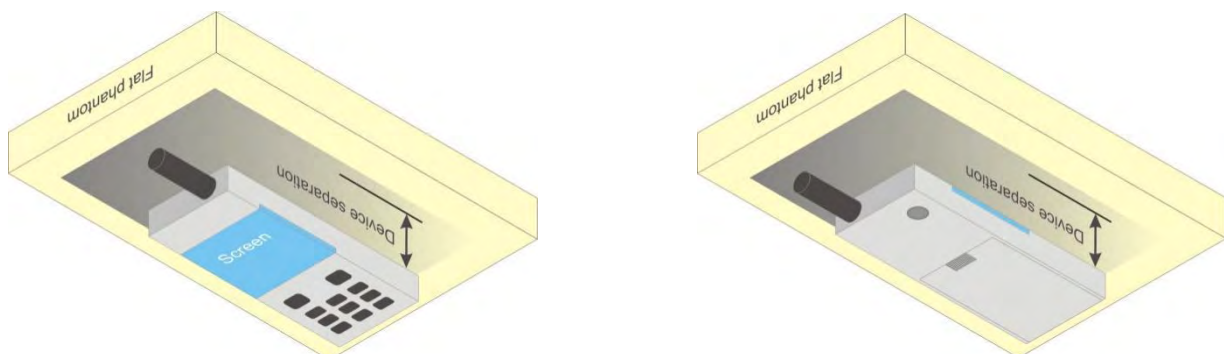
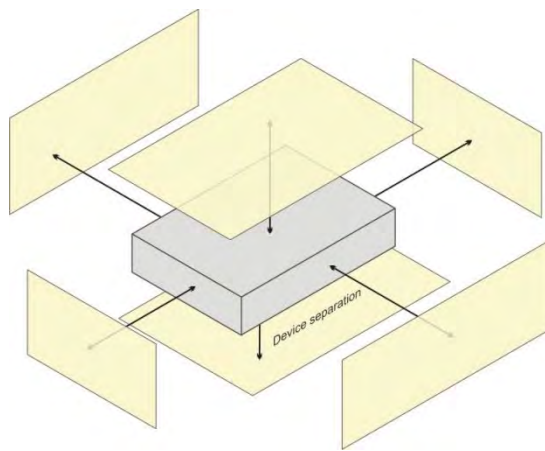

Fig-4.4 Illustration for Body Worn Position

4.2.3 Hotspot Mode Exposure Conditions

For handsets that support hotspot mode operations, with wireless router capabilities and various web browsing functions, the relevant hand and body exposure conditions are tested according to the hotspot SAR procedures in KDB 941225 D06. A test separation distance of 10 mm is required between the phantom and all surfaces and edges with a transmitting antenna located within 25 mm from that surface or edge. When the form factor of a handset is smaller than 9 cm x 5 cm, a test separation distance of 5 mm (instead of 10 mm) is required for testing hotspot mode. When the separation distance required for body-worn accessory testing is larger than or equal to that tested for hotspot mode, in the same wireless mode and for the same surface of the phone, the hotspot mode SAR data may be used to support body-worn accessory SAR compliance for that particular configuration (surface).



Based on the antenna location shown on appendix E of this report, the SAR testing required for hotspot mode is listed as below.

Antenna	Front Face	Rear Face	Left Side	Right Side	Top Side	Bottom Side
WWAN-Ant 1	√	√		√		√
WWAN-Ant 4	√	√		√	√	
WLAN-Ant 5	√	√	√		√	
WLAN / BT-Ant 6	√	√	√		√	

4.2.4 Extremity Exposure Conditions

For smart phones with a display diagonal dimension > 15 cm or an overall diagonal dimension > 16 cm that provide similar mobile web access and multimedia support found in mini-tablets or UMPC mini-tablets that support voice calls next to the ear, the following phablet procedures should be applied to evaluate SAR compliance for each applicable wireless mode and frequency band. Devices marketed as phablets, regardless of form factors and operating characteristics must be tested as a phablet to determine SAR compliance.

1. The normally required head and body-worn accessory SAR test procedures for handsets, including hotspot mode, must be applied.
2. The UMPC mini-tablet procedures must also be applied to test the SAR of all surfaces and edges with an antenna located at ≤ 25 mm from that surface or edge, in direct contact with a flat phantom, for 10-g extremity SAR according to the body-equivalent tissue dielectric parameters in KDB 865664 to address interactive hand use exposure conditions. The UMPC mini-tablet 1-g SAR at 5 mm is not required. When hotspot mode applies, 10-g extremity SAR is required only for the surfaces and edges with hotspot mode 1-g SAR > 1.2 W/kg. The normal tablet procedures in KDB 616217 are required when the over diagonal dimension of the device is > 20 cm. Hotspot mode SAR is not required when normal tablet procedures are applied. Extremity 10-g SAR is also not required for the front (top) surface of large form factor full size tablets. The more conservative tablet SAR results can be used to support the 10-g extremity SAR for phablet mode.
3. The simultaneous transmission operating configurations applicable to voice and data transmissions for both phone and mini-tablet modes must be taken into consideration separately for 1-g and 10-g SAR to determine the simultaneous transmission SAR test exclusion and measurement requirements for the relevant wireless modes and exposure conditions.

4.2.5 Simultaneous Transmission Possibilities

The simultaneous transmission possibilities for this device are listed as below.

Simultaneous TX Combination	Capable Transmit Configurations	Head	Body-worn	Hotspot	Extremity
1	WWAN + WLAN2.4G			Yes	
2	WWAN + WLAN5G			Yes	
3	WWAN + BT			Yes	

4.3 Tissue Verification

The measuring results for tissue simulating liquid are shown as below.

Test Date	Tissue Type	Frequency (MHz)	Liquid Temp. (°C)	Measured Conductivity (σ)	Measured Permittivity (ϵ_r)	Target Conductivity (σ)	Target Permittivity (ϵ_r)	Conductivity Deviation (%)	Permittivity Deviation (%)
Jan. 12, 2024	Head	750	22.5	0.908	42.869	0.89	41.90	2.02	2.31
Jan. 11, 2024	Head	835	22.6	0.944	42.985	0.90	41.50	4.89	3.58
Jan. 24, 2024	Head	1750	22.4	1.367	40.389	1.37	40.10	-0.22	0.72
Jan. 22, 2024	Head	1950	22.6	1.469	39.423	1.40	40.00	4.93	-1.44
Jan. 23, 2024	Head	1950	22.3	1.462	39.368	1.40	40.00	4.43	-1.58
Jan. 13, 2024	Head	2450	22.7	1.879	39.630	1.80	39.20	4.39	1.10
Jan. 25, 2024	Head	5250	22.5	4.562	35.208	4.76	35.90	-4.16	-1.93
Jan. 26, 2024	Head	5600	22.5	5.061	35.683	5.07	35.50	-0.18	0.52
Jan. 26, 2024	Head	5750	22.5	5.124	35.379	5.27	35.30	-2.77	0.22

The dielectric properties of the tissue simulating liquid must be measured within 24 hours before the SAR testing and within $\pm 5\%$ of the target values. Liquid temperature during the SAR testing must be within $\pm 2^\circ\text{C}$.

4.4 System Verification

The measuring result for system verification is tabulated as below.

<1g>

Test Date	Mode	Frequency (MHz)	1W Target SAR-1g (W/kg)	Measured SAR-1g (W/kg)	Normalized to 1W SAR-1g (W/kg)	Deviation (%)	Dipole S/N	Probe S/N	DAE S/N
Jan. 12, 2024	Head	750	8.45	2.17	8.68	2.72	1200	3985	755
Jan. 11, 2024	Head	835	9.60	2.48	9.92	3.33	4d265	3985	755
Jan. 24, 2024	Head	1750	36.60	8.98	35.92	-1.86	1176	3985	755
Jan. 22, 2024	Head	1950	40.3	10.3	41.20	2.23	1229	3985	755
Jan. 22, 2024	Head	1950	40.3	10.4	41.60	3.23	1229	3985	755
Jan. 23, 2024	Head	2450	52.80	13.1	52.40	-0.76	1048	3985	755
Jan. 13, 2024	Head	5250	76.90	7.43	74.30	-3.38	1315	3985	755
Jan. 26, 2024	Head	5600	81.9	8.15	81.50	-0.49	1315	3985	755
Jan. 25, 2024	Head	5750	76.10	7.82	78.20	2.76	1315	3985	755

<10g>

Test Date	Mode	Frequency (MHz)	1W Target SAR-10g (W/kg)	Measured SAR-10g (W/kg)	Normalized to 1W SAR-10g (W/kg)	Deviation (%)	Dipole S/N	Probe S/N	DAE S/N
Jan. 12, 2024	Head	750	5.57	1.42	5.68	1.97	1200	3985	755
Jan. 11, 2024	Head	835	6.25	1.61	6.44	3.04	4d265	3985	755
Jan. 24, 2024	Head	1750	19.20	4.75	19.00	-1.04	1176	3985	755
Jan. 22, 2024	Head	1950	20.30	5.14	20.56	1.28	1229	3985	755
Jan. 22, 2024	Head	1950	20.30	5.18	20.72	2.07	1229	3985	755
Jan. 23, 2024	Head	2450	24.20	6.11	24.44	0.99	1048	3985	755
Jan. 13, 2024	Head	5250	22.10	2.14	21.40	-3.17	1315	3985	755
Jan. 26, 2024	Head	5600	23.5	2.42	24.20	2.98	1315	3985	755
Jan. 25, 2024	Head	5750	21.70	2.22	22.20	2.30	1315	3985	755

Note:

Comparing to the reference SAR value provided by SPEAG, the validation data should be within its specification of 10 %. The result indicates the system check can meet the variation criterion and the plots can be referred to Appendix A of this report.

4.5 Maximum Output Power

4.5.1 Maximum Conducted Power

The maximum conducted average power (Unit: dBm) including tune-up tolerance please refer to Appendix D.

4.5.2 Measured Conducted Power Result

The measuring conducted average power (Unit: dBm) please refer to Appendix D.

4.6 SAR Testing Results

4.6.1 SAR Test Reduction Considerations

<KDB 447498 D04, General RF Exposure Guidance>

Testing of other required channels within the operating mode of a frequency band is not required when the reported SAR for the mid-band or highest output power channel is:

- (1) ≤ 0.8 W/kg or 2.0 W/kg, for 1-g or 10-g respectively, when the transmission band is ≤ 100 MHz
- (2) ≤ 0.6 W/kg or 1.5 W/kg, for 1-g or 10-g respectively, when the transmission band is between 100 MHz and 200 MHz
- (3) ≤ 0.4 W/kg or 1.0 W/kg, for 1-g or 10-g respectively, when the transmission band is ≥ 200 MHz

<KDB 941225 D01, 3G SAR Measurement Procedures>

The mode tested for SAR is referred to as the primary mode. The equivalent modes considered for SAR test reduction are denoted as secondary modes. Both primary and secondary modes must be in the same frequency band. When the maximum output power and tune-up tolerance specified for production units in a secondary mode is $\leq 1/4$ dB higher than the primary mode or when the highest reported SAR of the primary mode is scaled by the ratio of specified maximum output power and tune-up tolerance of secondary to primary mode and the adjusted SAR is ≤ 1.2 W/kg, SAR measurement is not required for the secondary mode.

<KDB 941225 D05, SAR Evaluation Considerations for LTE Devices>

- (1) QPSK with 1 RB and 50% RB allocation

Start with the largest channel bandwidth and measure SAR, using the RB offset and required test channel combination with the highest maximum output power among RB offsets at the upper edge, middle and lower edge of each required test channel. When the reported SAR is ≤ 0.8 W/kg, testing of the remaining RB offset configurations and required test channels is not required; otherwise, SAR is required for the remaining required test channels and only for the RB offset configuration with the highest output power for that channel. When the reported SAR of a required test channel is > 1.45 W/kg, SAR is required for all three RB offset configurations for that required test channel.

- (2) QPSK with 100% RB allocation

SAR is not required when the highest maximum output power for 100% RB allocation is less than the highest maximum output power in 50% and 1 RB allocations and the highest reported SAR for 1 RB and 50% RB allocation are ≤ 0.8 W/kg. Otherwise, SAR is measured for the highest output power channel; and if the reported SAR is > 1.45 W/kg, the remaining required test channels must also be tested.

- (3) Higher order modulations

SAR is required only when the highest maximum output power for the configuration in the higher order modulation is $> 1/2$ dB higher than the same configuration in QPSK or when the reported SAR for the QPSK configuration is $>$

1.45 W/kg.

(4) Other channel bandwidth

SAR is required when the highest maximum output power of the smaller channel bandwidth is $> 1/2$ dB higher than the equivalent channel configurations in the largest channel bandwidth configuration or the reported SAR of a configuration for the largest channel bandwidth is > 1.45 W/kg.

<KDB 248227 D01, SAR Guidance for Wi-Fi Transmitters>

- (1) For handsets operating next to ear, hotspot mode or mini-tablet configurations, the initial test position procedures were applied. The test position with the highest extrapolated peak SAR will be used as the initial test position. When the reported SAR of initial test position is ≤ 0.4 W/kg, SAR testing for remaining test positions is not required. Otherwise, SAR is evaluated at the subsequent highest peak SAR positions until the reported SAR result is ≤ 0.8 W/kg or all test positions are measured.
- (2) For WLAN 2.4 GHz, the highest measured maximum output power channel for DSSS was selected for SAR measurement. When the reported SAR is ≤ 0.8 W/kg, no further SAR testing is required. Otherwise, SAR is evaluated at the next highest measured output power channel. When any reported SAR is > 1.2 W/kg, SAR is required for the third channel. For OFDM modes (802.11g/n), SAR is not required when the highest reported SAR for DSSS is adjusted by the ratio of OFDM to DSSS specified maximum output power and it is ≤ 1.2 W/kg.
- (3) For WLAN 5 GHz, the initial test configuration was selected according to the transmission mode with the highest maximum output power. When the reported SAR of initial test configuration is > 0.8 W/kg, SAR is required for the subsequent highest measured output power channel until the reported SAR result is ≤ 1.2 W/kg or all required channels are measured. For other transmission modes, SAR is not required when the highest reported SAR for initial test configuration is adjusted by the ratio of subsequent test configuration to initial test configuration specified maximum output power and it is ≤ 1.2 W/kg.

4.6.2 SAR Results for Head Exposure Condition

<GSM&WCDMA>

Plot No.	Band	Mode	Test Position	Ch.	Sample	Ant.	Power Reduction	Max. Tune-up Power (dBm)	Measured Conducted Power (dBm)	Power Drift	Measured SAR-1g (W/kg)	Tune-up Scaling Factor	Scaled SAR-1g (W/kg)
P01	GSM850	GPRS 4Tx Slot	Right Cheek	251	1	1	Full	30.00	28.06	0.11	0.119	1.563	0.19
	GSM850	GPRS 4Tx Slot	Right Tilted	251	1	1	Full	30.00	28.06	-0.09	0.052	1.563	0.08
	GSM850	GPRS 4Tx Slot	Left Cheek	251	1	1	Full	30.00	28.06	-0.02	0.157	1.563	0.25
	GSM850	GPRS 4Tx Slot	Left Tilted	251	1	1	Full	30.00	28.06	0.13	0.072	1.563	0.11
P02	GSM1900	GPRS 4Tx Slot	Right Cheek	810	1	4	DS13/6	22.00	20.25	0.11	0.452	1.496	0.68
	GSM1900	GPRS 4Tx Slot	Right Tilted	810	1	4	DS13/6	22.00	20.25	0.05	0.594	1.496	0.89
	GSM1900	GPRS 4Tx Slot	Left Cheek	810	1	4	DS13/6	22.00	20.25	0.08	0.323	1.496	0.48
	GSM1900	GPRS 4Tx Slot	Left Tilted	810	1	4	DS13/6	22.00	20.25	0.12	0.402	1.496	0.60
	GSM1900	GPRS 4Tx Slot	Right Tilted	512	1	4	DS13/6	22.00	20.16	-0.10	0.327	1.528	0.50
	GSM1900	GPRS 4Tx Slot	Right Tilted	661	1	4	DS13/6	22.00	20.09	-0.03	0.419	1.552	0.65
P03	WCDMA II	RMC12.2K	Right Cheek	9538	1	4	DS13	19.00	17.88	0.16	0.709	1.294	0.92
	WCDMA II	RMC12.2K	Right Tilted	9538	1	4	DS13	19.00	17.88	-0.05	0.754	1.294	0.98
	WCDMA II	RMC12.2K	Left Cheek	9538	1	4	DS13	19.00	17.88	0.14	0.526	1.294	0.68
	WCDMA II	RMC12.2K	Left Tilted	9538	1	4	DS13	19.00	17.88	0.05	0.688	1.294	0.89
	WCDMA II	RMC12.2K	Right Cheek	9262	1	4	DS13	19.00	17.85	0.12	0.765	1.303	1.00
	WCDMA II	RMC12.2K	Right Cheek	9400	1	4	DS13	19.00	17.67	0.03	0.762	1.358	1.04
	WCDMA II	RMC12.2K	Right Tilted	9262	1	4	DS13	19.00	17.85	-0.17	0.761	1.303	0.99
	WCDMA II	RMC12.2K	Right Tilted	9400	1	4	DS13	19.00	17.67	0.11	0.965	1.358	1.31
	WCDMA II	RMC12.2K	Left Tilted	9262	1	4	DS13	19.00	17.85	0.08	0.651	1.303	0.85
	WCDMA II	RMC12.2K	Left Tilted	9400	1	4	DS13	19.00	17.67	0.04	0.690	1.358	0.94
	WCDMA II	RMC12.2K	Right Cheek	9538	1	4	DS16	18.50	17.51	0.02	0.548	1.256	0.69
	WCDMA II	RMC12.2K	Right Tilted	9538	1	4	DS16	18.50	17.51	0.01	0.758	1.256	0.95
	WCDMA II	RMC12.2K	Left Cheek	9538	1	4	DS16	18.50	17.51	-0.15	0.401	1.256	0.50
WCDMA II	RMC12.2K	Left Tilted	9538	1	4	DS16	18.50	17.51	0.08	0.496	1.256	0.62	
WCDMA II	RMC12.2K	Right Tilted	9262	1	4	DS16	18.50	17.47	0.13	0.649	1.268	0.82	
WCDMA II	RMC12.2K	Right Tilted	9400	1	4	DS16	18.50	17.26	-0.07	0.793	1.330	1.06	
P04	WCDMA V	RMC12.2K	Right Cheek	4182	1	1	Full	25.50	23.86	0.14	0.121	1.459	0.18
	WCDMA V	RMC12.2K	Right Tilted	4182	1	1	Full	25.50	23.86	0.07	0.054	1.459	0.08
	WCDMA V	RMC12.2K	Left Cheek	4182	1	1	Full	25.50	23.86	-0.02	0.178	1.459	0.26
	WCDMA V	RMC12.2K	Left Tilted	4182	1	1	Full	25.50	23.86	0.13	0.096	1.459	0.14

<LTE FDD>

Plot No.	Band	Mode	Test Position	Ch.	Sample	Ant.	Power Reduction	RB#	RB Offset	Max. Tune-up Power (dBm)	Measured Conducted Power (dBm)	Power Drift	Measured SAR-1g (W/kg)	Duty Cycle Scaling Factor	Tune-up Scaling Factor	Scaled SAR-1g (W/kg)
P05	LTE 2	QPSK20M	Right Cheek	18900	1	4	DS13	1	50	20.00	18.89	0.04	0.746	-	1.291	0.96
	LTE 2	QPSK20M	Right Tilted	18900	1	4	DS13	1	50	20.00	18.89	-0.12	0.717	-	1.291	0.93
	LTE 2	QPSK20M	Left Cheek	18900	1	4	DS13	1	50	20.00	18.89	0.03	0.544	-	1.291	0.70
	LTE 2	QPSK20M	Left Tilted	18900	1	4	DS13	1	50	20.00	18.89	0.13	0.653	-	1.291	0.84
	LTE 2	QPSK20M	Right Cheek	18900	1	4	DS13	50	25	20.00	18.68	0.09	0.808	-	1.355	1.09
	LTE 2	QPSK20M	Right Tilted	18900	1	4	DS13	50	25	20.00	18.68	0.06	1.040	-	1.355	1.41
	LTE 2	QPSK20M	Left Cheek	18900	1	4	DS13	50	25	20.00	18.68	0.14	0.527	-	1.355	0.71
	LTE 2	QPSK20M	Left Tilted	18900	1	4	DS13	50	25	20.00	18.68	-0.05	0.649	-	1.355	0.88
	LTE 2	QPSK20M	Right Cheek	18700	1	4	DS13	1	50	20.00	18.82	0.16	0.785	-	1.312	1.03
	LTE 2	QPSK20M	Right Cheek	19100	1	4	DS13	1	50	20.00	18.68	0.07	0.760	-	1.355	1.03
	LTE 2	QPSK20M	Right Tilted	18700	1	4	DS13	1	50	20.00	18.82	0.12	0.842	-	1.312	1.10
	LTE 2	QPSK20M	Right Tilted	19100	1	4	DS13	1	50	20.00	18.68	0.15	0.855	-	1.355	1.16
	LTE 2	QPSK20M	Left Tilted	18700	1	4	DS13	1	50	20.00	18.82	0.05	0.530	-	1.312	0.70
	LTE 2	QPSK20M	Left Tilted	19100	1	4	DS13	1	50	20.00	18.68	0.16	0.577	-	1.355	0.78
	LTE 2	QPSK20M	Right Cheek	18700	1	4	DS13	50	25	20.00	18.36	0.07	0.796	-	1.459	1.16
	LTE 2	QPSK20M	Right Cheek	19100	1	4	DS13	50	25	20.00	18.37	-0.12	0.783	-	1.455	1.14
	LTE 2	QPSK20M	Right Tilted	18700	1	4	DS13	50	25	20.00	18.36	0.05	0.947	-	1.459	1.38
	LTE 2	QPSK20M	Right Tilted	19100	1	4	DS13	50	25	20.00	18.37	0.04	0.861	-	1.455	1.25
	LTE 2	QPSK20M	Left Tilted	18700	1	4	DS13	50	25	20.00	18.36	0.13	0.529	-	1.459	0.77
	LTE 2	QPSK20M	Left Tilted	19100	1	4	DS13	50	25	20.00	18.37	0.15	0.576	-	1.455	0.84
LTE 2	QPSK20M	Right Tilted	18900	1	4	DS13	100	0	20.00	18.30	0.06	0.830	-	1.479	1.23	
LTE 2	QPSK20M	Right Cheek	18900	1	4	DS13	100	0	20.00	18.30	-0.03	0.786	-	1.479	1.16	
LTE 2	QPSK20M	Left Tilted	18900	1	4	DS13	100	0	20.00	18.30	0.12	0.670	-	1.479	0.99	

Plot No.	Band	Mode	Test Position	Ch.	Sample	Ant.	Power Reduction	RB#	RB Offset	Max. Tune-up Power (dBm)	Measured Conducted Power (dBm)	Power Drift	Measured SAR-1g (W/kg)	Duty Cycle Scaling Factor	Tune-up Scaling Factor	Scaled SAR-1g (W/kg)
	LTE 66/4	QPSK20M	Right Tilted	132322	1	4	DS16	1	99	21.00	20.15	-0.02	0.597	-	1.216	0.73
	LTE 66/4	QPSK20M	Left Cheek	132322	1	4	DS16	1	99	21.00	20.15	0.13	0.406	-	1.216	0.49
	LTE 66/4	QPSK20M	Left Tilted	132322	1	4	DS16	1	99	21.00	20.15	-0.04	0.524	-	1.216	0.64
	LTE 66/4	QPSK20M	Right Cheek	132322	1	4	DS16	50	50	21.00	19.87	-0.05	0.538	-	1.297	0.70
	LTE 66/4	QPSK20M	Right Tilted	132322	1	4	DS16	50	50	21.00	19.87	-0.11	0.568	-	1.297	0.74
	LTE 66/4	QPSK20M	Left Cheek	132322	1	4	DS16	50	50	21.00	19.87	0.09	0.388	-	1.297	0.50
	LTE 66/4	QPSK20M	Left Tilted	132322	1	4	DS16	50	50	21.00	19.87	0.14	0.489	-	1.297	0.63

<WLAN&BT>

Plot No.	Band	Mode	Test Position	Ch.	Sample	Ant.	Power Reduction	Duty Cycle %	Max. Tune-up Power (dBm)	Measured Conducted Power (dBm)	Power Drift	Measured SAR-1g (W/kg)	Duty Cycle Factor	Tune-up Scaling Factor	Scaled SAR-1g (W/kg)
	WLAN2.4G	802.11b	Right Cheek	6	1	5	Full	97.36	19.50	18.62	0.02	0.435	1.027	1.226	0.55
	WLAN2.4G	802.11b	Right Tilted	6	1	5	Full	97.36	19.50	18.62	0.05	0.509	1.027	1.226	0.64
P10	WLAN2.4G	802.11b	Left Cheek	6	1	5	Full	97.36	19.50	18.62	-0.10	0.951	1.027	1.226	1.20
	WLAN2.4G	802.11b	Left Tilted	6	1	5	Full	97.36	19.50	18.62	-0.17	0.596	1.027	1.226	0.75
	WLAN2.4G	802.11b	Left Cheek	1	1	5	Full	97.36	19.50	17.99	0.13	0.664	1.027	1.416	0.97
	WLAN2.4G	802.11b	Left Cheek	11	1	5	Full	97.36	19.50	18.25	0.06	0.485	1.027	1.333	0.66
	WLAN2.4G	802.11b	Right Cheek	6	1	5	DS16	97.36	14.00	13.01	0.06	0.131	1.027	1.256	0.17
	WLAN2.4G	802.11b	Right Tilted	6	1	5	DS16	97.36	14.00	13.01	-0.02	0.168	1.027	1.256	0.22
	WLAN2.4G	802.11b	Left Cheek	6	1	5	DS16	97.36	14.00	13.01	0.04	0.314	1.027	1.256	0.41
	WLAN2.4G	802.11b	Left Tilted	6	1	5	DS16	97.36	14.00	13.01	0.13	0.208	1.027	1.256	0.27
	WLAN5G	802.11a	Right Cheek	40	1	6	DS13	98.28	15.50	14.74	0.14	0.322	1.018	1.193	0.39
	WLAN5G	802.11a	Right Tilted	40	1	6	DS13	98.28	15.50	14.74	0.07	0.409	1.018	1.193	0.50
	WLAN5G	802.11a	Left Cheek	40	1	6	DS13	98.28	15.50	14.74	0.11	0.476	1.018	1.193	0.58
	WLAN5G	802.11a	Left Tilted	40	1	6	DS13	98.28	15.50	14.74	0.05	0.812	1.018	1.193	0.99
P11	WLAN5G	802.11a	Left Tilted	48	1	6	DS13	98.28	15.50	14.63	0.09	0.899	1.018	1.222	1.12
	WLAN5G	802.11a	Right Cheek	40	1	6	DS16	98.28	9.00	8.28	0.05	0.123	1.018	1.180	0.15
	WLAN5G	802.11a	Right Tilted	40	1	6	DS16	98.28	9.00	8.28	0.03	0.204	1.018	1.180	0.24
	WLAN5G	802.11a	Left Cheek	40	1	6	DS16	98.28	9.00	8.28	0.17	0.164	1.018	1.180	0.20
	WLAN5G	802.11a	Left Tilted	40	1	6	DS16	98.28	9.00	8.28	0.08	0.279	1.018	1.180	0.34
	WLAN5G	802.11a	Right Cheek	60	1	6	DS13	98.28	15.50	14.92	0.14	0.442	1.018	1.144	0.51
	WLAN5G	802.11a	Right Tilted	60	1	6	DS13	98.28	15.50	14.92	0.08	0.573	1.018	1.144	0.67
	WLAN5G	802.11a	Left Cheek	60	1	6	DS13	98.28	15.50	14.92	-0.07	0.761	1.018	1.144	0.89
	WLAN5G	802.11a	Left Tilted	60	1	6	DS13	98.28	15.50	14.92	0.13	0.738	1.018	1.144	0.86
	WLAN5G	802.11a	Left Cheek	52	1	6	DS13	98.28	15.50	14.88	0.06	0.541	1.018	1.153	0.63
P12	WLAN5G	802.11a	Left Tilted	52	1	6	DS13	98.28	15.50	14.88	-0.06	0.946	1.018	1.153	1.11
	WLAN5G	802.11a	Right Cheek	60	1	6	DS16	98.28	12.00	11.21	0.07	0.214	1.018	1.199	0.26
	WLAN5G	802.11a	Right Tilted	60	1	6	DS16	98.28	12.00	11.21	-0.03	0.306	1.018	1.199	0.37
	WLAN5G	802.11a	Left Cheek	60	1	6	DS16	98.28	12.00	11.21	0.11	0.262	1.018	1.199	0.32
	WLAN5G	802.11a	Left Tilted	60	1	6	DS16	98.28	12.00	11.21	0.02	0.497	1.018	1.199	0.61
	WLAN5G	802.11a	Right Cheek	140	1	6	Full	98.28	18.00	17.01	0.06	0.285	1.018	1.256	0.36
	WLAN5G	802.11a	Right Tilted	140	1	6	Full	98.28	18.00	17.01	-0.09	0.340	1.018	1.256	0.43
	WLAN5G	802.11a	Left Cheek	140	1	6	Full	98.28	18.00	17.01	0.13	0.308	1.018	1.256	0.39
P13	WLAN5G	802.11a	Left Tilted	140	1	6	Full	98.28	18.00	17.01	0.01	0.557	1.018	1.256	0.71
	WLAN5G	802.11a	Right Cheek	140	1	6	DS16	98.28	13.50	12.87	0.04	0.103	1.018	1.155	0.12
	WLAN5G	802.11a	Right Tilted	140	1	6	DS16	98.28	13.50	12.87	0.01	0.146	1.018	1.155	0.17
	WLAN5G	802.11a	Left Cheek	140	1	6	DS16	98.28	13.50	12.87	0.15	0.109	1.018	1.155	0.13
	WLAN5G	802.11a	Left Tilted	140	1	6	DS16	98.28	13.50	12.87	-0.09	0.232	1.018	1.155	0.27
	WLAN5G	802.11ac-VHT20	Right Cheek	149	1	6	Full	96.31	17.50	16.96	0.06	0.288	1.038	1.132	0.34
	WLAN5G	802.11ac-VHT20	Right Tilted	149	1	6	Full	96.31	17.50	16.96	-0.03	0.361	1.038	1.132	0.42
	WLAN5G	802.11ac-VHT20	Left Cheek	149	1	6	Full	96.31	17.50	16.96	0.14	0.312	1.038	1.132	0.37
P14	WLAN5G	802.11ac-VHT20	Left Tilted	149	1	6	Full	96.31	17.50	16.96	-0.09	0.549	1.038	1.132	0.65
	WLAN5G	802.11ac-VHT20	Right Cheek	149	1	6	DS16	96.31	13.50	12.74	0.11	0.118	1.038	1.192	0.15
	WLAN5G	802.11ac-VHT20	Right Tilted	149	1	6	DS16	96.31	13.50	12.74	0.02	0.171	1.038	1.192	0.21
	WLAN5G	802.11ac-VHT20	Left Cheek	149	1	6	DS16	96.31	13.50	12.74	0.17	0.142	1.038	1.192	0.18
	WLAN5G	802.11ac-VHT20	Left Tilted	149	1	6	DS16	96.31	13.50	12.74	-0.07	0.251	1.038	1.192	0.31
	BT	GFSK	Right Cheek	0	1	6	Full	77.20	14.00	12.83	0.04	0.047	1.295	1.310	0.08
	BT	GFSK	Right Tilted	0	1	6	Full	77.20	14.00	12.83	-0.09	0.049	1.295	1.310	0.08

Plot No.	Band	Mode	Test Position	Ch.	Sample	Ant.	Power Reduction	Duty Cycle %	Max. Tune-up Power (dBm)	Measured Conducted Power (dBm)	Power Drift	Measured SAR-1g (W/kg)	Duty Cycle Factor	Tune-up Scaling Factor	Scaled SAR-1g (W/kg)
P15	BT	GFSK	Left Cheek	0	1	6	Full	77.20	14.00	12.83	-0.04	0.151	1.295	1.310	0.26
	BT	GFSK	Left Tilted	0	1	6	Full	77.20	14.00	12.83	0.17	0.102	1.295	1.310	0.17

4.6.3 SAR Results for Body-worn Exposure Condition (Separation Distance is 1.0 cm Gap)

<GSM&WCDMA>

Plot No.	Band	Mode	Test Position	Separation Distance (cm)	Ch.	Sample	Ant.	Power Reduction	Max. Tune-up Power (dBm)	Measured Conducted Power (dBm)	Power Drift	Measured SAR-1g (W/kg)	Tune-up Scaling Factor	Scaled SAR-1g (W/kg)
	GSM850	GPRS 4Tx Slot	Front Face	1	251	1	1	Full	30.00	28.06	0.13	0.118	1.563	0.18
P16	GSM850	GPRS 4Tx Slot	Rear Face	1	251	1	1	Full	30.00	28.06	-0.02	0.203	1.563	0.32
	GSM1900	GPRS 4Tx Slot	Front Face	1	810	1	4	DSI2/5	24.50	23.10	0.07	0.229	1.380	0.32
P17	GSM1900	GPRS 4Tx Slot	Rear Face	1	810	1	4	DSI2/5	24.50	23.10	-0.09	0.423	1.380	0.58
	GSM1900	GPRS 4Tx Slot	Front Face	1.1	810	1	4	Full	27.50	25.84	0.04	0.312	1.466	0.46
	GSM1900	GPRS 4Tx Slot	Rear Face	2.2	810	1	4	Full	27.50	25.84	-0.09	0.157	1.466	0.23
	WCDMA II	RMC12.2K	Front Face	1	9538	1	4	DSI5/2	22.00	20.99	0.11	0.290	1.262	0.37
P18	WCDMA II	RMC12.2K	Rear Face	1	9538	1	4	DSI5/2	22.00	20.99	0.13	0.733	1.262	0.92
	WCDMA II	RMC12.2K	Rear Face	1	9262	1	4	DSI5/2	22.00	20.99	-0.14	0.535	1.262	0.68
	WCDMA II	RMC12.2K	Rear Face	1	9400	1	4	DSI5/2	22.00	20.99	-0.07	0.694	1.262	0.88
	WCDMA II	RMC12.2K	Front Face	1.1	9538	1	4	Full	25.50	23.69	0.05	0.503	1.517	0.76
	WCDMA II	RMC12.2K	Rear Face	2.2	9538	1	4	Full	25.50	23.69	0.14	0.233	1.517	0.35
	WCDMA V	RMC12.2K	Front Face	1	4182	1	1	Full	25.50	23.86	0.07	0.139	1.459	0.20
P19	WCDMA V	RMC12.2K	Rear Face	1	4182	1	1	Full	25.50	23.86	0.03	0.235	1.459	0.34

<LTE FDD>

Plot No.	Band	Mode	Test Position	Separation Distance (cm)	Ch.	Sample	Ant.	Power Reduction	RB#	RB Offset	Max. Tune-up Power (dBm)	Measured Conducted Power (dBm)	Power Drift	Measured SAR-1g (W/kg)	Tune-up Scaling Factor	Scaled SAR-1g (W/kg)
	LTE 2	QPSK20M	Front Face	1	18900	1	4	DSI2	1	50	23.00	22.10	0.13	0.428	1.230	0.53
	LTE 2	QPSK20M	Rear Face	1	18900	1	4	DSI2	1	50	23.00	22.10	0.01	0.824	1.230	1.01
	LTE 2	QPSK20M	Front Face	1	18900	1	4	DSI2	50	25	23.00	21.55	0.06	0.419	1.396	0.59
	LTE 2	QPSK20M	Rear Face	1	18900	1	4	DSI2	50	25	23.00	21.55	-0.04	0.826	1.396	1.15
	LTE 2	QPSK20M	Front Face	1	18700	1	4	DSI2	1	50	23.00	22.02	-0.04	0.794	1.253	0.99
	LTE 2	QPSK20M	Rear Face	1	19100	1	4	DSI2	1	50	23.00	22.07	-0.09	0.712	1.239	0.88
	LTE 2	QPSK20M	Rear Face	1	18700	1	4	DSI2	50	25	23.00	21.44	-0.08	0.810	1.432	1.16
P20	LTE 2	QPSK20M	Rear Face	1	19100	1	4	DSI2	50	25	23.00	21.54	-0.02	0.845	1.400	1.18
	LTE 2	QPSK20M	Rear Face	1	19100	1	4	DSI2	100	0	23.00	21.49	0.14	0.726	1.416	1.03
	LTE 2	QPSK20M	Front Face	1.1	18900	1	4	Full	1	50	25.00	23.55	0.05	0.497	1.396	0.69
	LTE 2	QPSK20M	Rear Face	2.2	18900	1	4	Full	1	50	25.00	23.55	-0.07	0.266	1.396	0.37
	LTE 2	QPSK20M	Front Face	1.1	18900	1	4	Full	50	25	24.00	22.62	0.12	0.405	1.374	0.56
	LTE 2	QPSK20M	Rear Face	2.2	18900	1	4	Full	50	25	24.00	22.62	0.08	0.212	1.374	0.29
	LTE 2	QPSK20M	Front Face	1	18900	1	4	DSI5	1	50	22.50	21.72	0.11	0.364	1.197	0.44
	LTE 2	QPSK20M	Rear Face	1	18900	1	4	DSI5	1	50	22.50	21.72	-0.12	0.655	1.197	0.78
	LTE 2	QPSK20M	Front Face	1	18900	1	4	DSI5	50	25	22.00	21.33	0.06	0.329	1.167	0.38
	LTE 2	QPSK20M	Rear Face	1	18900	1	4	DSI5	50	25	22.00	21.33	-0.02	0.809	1.167	0.94
	LTE 2	QPSK20M	Rear Face	1	18700	1	4	DSI5	50	25	22.00	21.24	0.13	0.474	1.191	0.56
	LTE 2	QPSK20M	Rear Face	1	19100	1	4	DSI5	50	25	22.00	21.28	-0.03	0.688	1.180	0.81
	LTE 2	QPSK20M	Rear Face	1	18900	1	4	DSI5	100	0	22.00	21.25	0.13	0.590	1.189	0.70
	LTE 2	QPSK20M	Front Face	1.1	18900	1	4	Full	1	50	25.00	23.55	0.04	0.497	1.396	0.69
	LTE 2	QPSK20M	Rear Face	2.2	18900	1	4	Full	1	50	25.00	23.55	0.13	0.266	1.396	0.37
	LTE 2	QPSK20M	Front Face	1.1	18900	1	4	Full	50	25	24.00	22.62	-0.09	0.405	1.374	0.56
	LTE 2	QPSK20M	Rear Face	2.2	18900	1	4	Full	50	25	24.00	22.62	0.02	0.212	1.374	0.29
	LTE 5	QPSK10M	Front Face	1	20450	1	1	Full	1	49	25.50	24.32	0.15	0.133	1.312	0.17
P21	LTE 5	QPSK10M	Rear Face	1	20450	1	1	Full	1	49	25.50	24.32	-0.01	0.313	1.312	0.41
	LTE 5	QPSK10M	Front Face	1	20450	1	1	Full	25	25	24.50	23.15	0.01	0.093	1.365	0.13
	LTE 5	QPSK10M	Rear Face	1	20450	1	1	Full	25	25	24.50	23.15	0.04	0.188	1.365	0.26
	LTE 12	QPSK10M	Front Face	1	23130	1	1	Full	1	0	25.50	24.24	-0.02	0.133	1.337	0.18
P22	LTE 12	QPSK10M	Rear Face	1	23130	1	1	Full	1	0	25.50	24.24	-0.06	0.176	1.337	0.24

Plot No.	Band	Mode	Test Position	Separation Distance (cm)	Ch.	Sample	Ant.	Power Reduction	RB#	RB Offset	Max. Tune-up Power (dBm)	Measured Conducted Power (dBm)	Power Drift	Measured SAR-1g (W/kg)	Tune-up Scaling Factor	Scaled SAR-1g (W/kg)
	LTE 12	QPSK10M	Front Face	1	23130	1	1	Full	25	0	24.50	23.23	0.04	0.121	1.340	0.16
	LTE 12	QPSK10M	Rear Face	1	23130	1	1	Full	25	0	24.50	23.23	0.07	0.146	1.340	0.20
P23	LTE 13	QPSK10M	Front Face	1	23230	1	1	Full	1	49	25.50	24.06	0.02	0.144	1.393	0.20
	LTE 13	QPSK10M	Rear Face	1	23230	1	1	Full	1	49	25.50	24.06	0.07	0.167	1.393	0.23
	LTE 13	QPSK10M	Front Face	1	23230	1	1	Full	25	25	24.50	23.18	0.01	0.113	1.355	0.15
	LTE 13	QPSK10M	Rear Face	1	23230	1	1	Full	25	25	24.50	23.18	-0.16	0.159	1.355	0.22
P24	LTE 66	QPSK20M	Front Face	1	132322	1	4	DSI5/2	1	99	23.00	21.96	0.06	0.302	1.271	0.38
	LTE 66	QPSK20M	Rear Face	1	132322	1	4	DSI5/2	1	99	23.00	21.96	-0.02	0.512	1.271	0.65
	LTE 66	QPSK20M	Front Face	1	132322	1	4	DSI5/2	50	50	23.00	21.77	0.06	0.280	1.327	0.37
	LTE 66	QPSK20M	Rear Face	1	132322	1	4	DSI5/2	50	50	23.00	21.77	0.03	0.451	1.327	0.60
	LTE 66	QPSK20M	Front Face	1.1	132322	1	4	Full	1	99	25.00	23.45	0.13	0.316	1.429	0.45
	LTE 66	QPSK20M	Rear Face	2.2	132322	1	4	Full	1	99	25.00	23.45	-0.02	0.146	1.429	0.21
	LTE 66	QPSK20M	Front Face	1.1	132322	1	4	Full	50	50	24.00	22.37	-0.04	0.245	1.455	0.36
	LTE 66	QPSK20M	Rear Face	2.2	132322	1	4	Full	50	50	24.00	22.37	0.11	0.112	1.455	0.16

<WLAN&BT>

Plot No.	Band	Mode	Test Position	Separation Distance (cm)	Ch.	Sample	Ant.	Power Reduction	Duty Cycle %	Max. Tune-up Power (dBm)	Measured Conducted Power (dBm)	Power Drift	Measured SAR-1g (W/kg)	Duty Cycle Factor	Tune-up Scaling Factor	Scaled SAR-1g (W/kg)
P25	WLAN2.4G	802.11b	Front Face	1	6	1	5	Full	97.36	19.50	18.62	-0.06	0.182	1.027	1.226	0.23
	WLAN2.4G	802.11b	Rear Face	1	6	1	5	Full	97.36	19.50	18.62	-0.05	0.451	1.027	1.226	0.57
	WLAN2.4G	802.11b	Front Face	1	6	1	5	DSI5	97.36	17.50	16.95	0.11	0.129	1.027	1.135	0.15
	WLAN2.4G	802.11b	Rear Face	1	6	1	5	DSI5	97.36	17.50	16.95	-0.05	0.340	1.027	1.135	0.40
P26	WLAN5G	802.11n-HT20	Front Face	1	36	1	6	DSI2	98.15	17.00	16.39	0.07	0.157	1.019	1.151	0.18
	WLAN5G	802.11n-HT20	Rear Face	1	36	1	6	DSI2	98.15	17.00	16.39	-0.02	0.810	1.019	1.151	0.95
	WLAN5G	802.11n-HT20	Rear Face	1	40	1	6	DSI2	98.15	17.00	16.12	-0.08	0.878	1.019	1.225	1.10
	WLAN5G	802.11n-HT20	Front Face	1	36	1	6	DSI5	98.15	14.00	13.04	0.11	0.088	1.019	1.247	0.11
	WLAN5G	802.11n-HT20	Rear Face	1	36	1	6	DSI5	98.15	14.00	13.04	0.09	0.292	1.019	1.247	0.37
	WLAN5G	802.11n-HT20	Front Face	1.1	36	1	6	Full	98.15	18.00	16.57	0.05	0.169	1.019	1.391	0.24
	WLAN5G	802.11n-HT20	Rear Face	2.2	36	1	6	Full	98.15	18.00	16.57	0.13	0.411	1.019	1.391	0.58
	WLAN5G	802.11a	Front Face	1	60	1	6	Full	98.28	18.00	16.54	0.08	0.219	1.018	1.400	0.31
P27	WLAN5G	802.11a	Rear Face	1	60	1	6	Full	98.28	18.00	16.54	-0.04	0.992	1.018	1.400	1.41
	WLAN5G	802.11a	Rear Face	1	52	1	6	Full	98.28	18.00	16.44	0.13	0.687	1.018	1.432	1.00
	WLAN5G	802.11a	Rear Face	1	60	2	6	Full	98.28	18.00	16.54	0.02	0.957	1.018	1.400	1.36
	WLAN5G	802.11a	Front Face	1	60	1	6	DSI5	98.28	12.00	11.21	-0.07	0.102	1.018	1.199	0.12
	WLAN5G	802.11a	Rear Face	1	60	1	6	DSI5	98.28	12.00	11.21	0.01	0.341	1.018	1.199	0.42
	WLAN5G	802.11a	Front Face	1	140	1	6	Full	98.28	18.00	17.01	0.11	0.117	1.018	1.256	0.15
P28	WLAN5G	802.11a	Rear Face	1	140	1	6	Full	98.28	18.00	17.01	0.09	0.432	1.018	1.256	0.55
	WLAN5G	802.11a	Front Face	1	140	1	6	DSI5	98.28	16.50	15.54	-0.05	0.081	1.018	1.248	0.10
	WLAN5G	802.11a	Rear Face	1	140	1	6	DSI5	98.28	16.50	15.54	-0.09	0.302	1.018	1.248	0.38
	WLAN5G	802.11ac-VHT20	Front Face	1	149	1	6	Full	96.31	17.50	16.96	0.11	0.153	1.038	1.132	0.18
P29	WLAN5G	802.11ac-VHT20	Rear Face	1	149	1	6	Full	96.31	17.50	16.96	-0.02	0.424	1.038	1.132	0.50
	WLAN5G	802.11ac-VHT20	Front Face	1	149	1	6	DSI5	96.31	17.00	16.39	0.04	0.082	1.038	1.151	0.10
	WLAN5G	802.11ac-VHT20	Rear Face	1	149	1	6	DSI5	96.31	17.00	16.39	-0.06	0.378	1.038	1.151	0.45
P30	BT	GFSK	Front Face	1	0	1	6	Full	77.20	14.00	12.83	0.01	0.012	1.295	1.310	0.02
	BT	GFSK	Rear Face	1	0	1	6	Full	77.20	14.00	12.83	0.09	0.073	1.295	1.310	0.12

4.6.4 SAR Results for Hotspot Exposure Condition (Separation Distance is 1.0 cm Gap)

<GSM&WCDMA>

Plot No.	Band	Mode	Test Position	Separation Distance (cm)	Ch.	Sample	Ant.	Power Reduction	Max. Tune-up Power (dBm)	Measured Conducted Power (dBm)	Power Drift	Measured SAR-1g (W/kg)	Tune-up Scaling Factor	Scaled SAR-1g (W/kg)
P31	GSM850	GPRS 4Tx Slot	Front Face	1	251	1	1	Full	30.00	28.06	0.13	0.118	1.563	0.18
	GSM850	GPRS 4Tx Slot	Rear Face	1	251	1	1	Full	30.00	28.06	-0.02	0.203	1.563	0.32
	GSM850	GPRS 4Tx Slot	Left Side	1	251	1	1	Full	30.00	28.06	0.08	0.184	1.563	0.29
	GSM850	GPRS 4Tx Slot	Bottom Side	1	251	1	1	Full	30.00	28.06	-0.11	0.061	1.563	0.10
	GSM1900	GPRS 4Tx Slot	Front Face	1	810	1	4	DSI4	22.50	21.08	0.04	0.216	1.387	0.30



BUREAU VERITAS

FCC SAR Test Report



Certificate #6613.01

Plot No.	Band	Mode	Test Position	Separation Distance (cm)	Ch.	Sample	Ant.	Power Reduction	RB#	RB Offset	Duty Cycle %	Max. Tune-up Power (dBm)	Measured Conducted Power (dBm)	Power Drift	Measured SAR-1g (W/kg)	Tune-up Scaling Factor	Scaled SAR-1g (W/kg)
	LTE 66	QPSK20M	Rear Face	1	132322	1	4	DSI4	1	99	-	23.50	22.36	-0.07	0.541	1.300	0.70
	LTE 66	QPSK20M	Left Side	1	132322	1	4	DSI4	1	99	-	23.50	22.36	-0.09	0.170	1.300	0.22
P39	LTE 66	QPSK20M	Top Side	1	132322	1	4	DSI4	1	99	-	23.50	22.36	0.05	0.670	1.300	0.87
	LTE 66	QPSK20M	Front Face	1	132322	1	4	DSI4	50	50	-	23.50	22.08	-0.07	0.289	1.387	0.40
	LTE 66	QPSK20M	Rear Face	1	132322	1	4	DSI4	50	50	-	23.50	22.08	-0.08	0.521	1.387	0.72
	LTE 66	QPSK20M	Left Side	1	132322	1	4	DSI4	50	50	-	23.50	22.08	0.14	0.160	1.387	0.22
	LTE 66	QPSK20M	Top Side	1	132322	1	4	DSI4	50	50	-	23.50	22.08	0.03	0.573	1.387	0.79
	LTE 66	QPSK20M	Top Side	1	132072	1	4	DSI4	1	99	-	23.50	22.15	0.11	0.502	1.365	0.69
	LTE 66	QPSK20M	Top Side	1	132572	1	4	DSI4	1	99	-	23.50	22.28	0.03	0.622	1.324	0.82
	LTE 66	QPSK20M	Top Side	1	132322	1	4	DSI4	100	0	-	23.50	22.06	0.08	0.553	1.393	0.77
	LTE 66	QPSK20M	Top Side	1.9	132322	1	4	Full	1	99	-	25.00	23.45	-0.04	0.295	1.429	0.42
	LTE 66	QPSK20M	Top Side	1.9	132322	1	4	Full	50	50	-	24.00	22.37	0.02	0.218	1.455	0.32

<WLAN&BT>

Plot No.	Band	Mode	Test Position	Separation Distance (cm)	Ch.	Sample	Ant.	Power Reduction	Duty Cycle%	Max. Tune-up Power (dBm)	Measured Conducted Power (dBm)	Power Drift	Measured SAR-1g (W/kg)	Duty Cycle Factor	Tune-up Scaling Factor	Scaled SAR-1g (W/kg)
	WLAN2.4G	802.11b	Front Face	1	6	1	5	Full	97.36	19.50	18.62	-0.06	0.182	1.027	1.226	0.23
P40	WLAN2.4G	802.11b	Rear Face	1	6	1	5	Full	97.36	19.50	18.62	-0.05	0.451	1.027	1.226	0.57
	WLAN2.4G	802.11b	Right Side	1	6	1	5	Full	97.36	19.50	18.62	-0.09	0.187	1.027	1.226	0.24
	WLAN2.4G	802.11b	Top Side	1	6	1	5	Full	97.36	19.50	18.62	-0.07	0.264	1.027	1.226	0.33
	WLAN5G	802.11n-HT20	Front Face	1	36	1	6	DSI5	98.15	14.00	13.04	0.03	0.088	1.019	1.247	0.11
P41	WLAN5G	802.11n-HT20	Rear Face	1	36	1	6	DSI5	98.15	14.00	13.04	-0.09	0.292	1.019	1.247	0.37
	WLAN5G	802.11n-HT20	Right Side	1	36	1	6	DSI5	98.15	14.00	13.04	0.07	0.173	1.019	1.247	0.22
	WLAN5G	802.11n-HT20	Top Side	1	36	1	6	DSI5	98.15	14.00	13.04	0.02	0.240	1.019	1.247	0.31
	WLAN5G	802.11ac-VHT20	Front Face	1	149	1	6	Full	96.31	17.50	16.96	0.11	0.153	1.038	1.132	0.18
P42	WLAN5G	802.11ac-VHT20	Rear Face	1	149	1	6	Full	96.31	17.50	16.96	-0.02	0.424	1.038	1.132	0.50
	WLAN5G	802.11ac-VHT20	Right Side	1	149	1	6	Full	96.31	17.50	16.96	0.03	0.119	1.038	1.132	0.14
	WLAN5G	802.11ac-VHT20	Top Side	1	149	1	6	Full	96.31	17.50	16.96	0.11	0.372	1.038	1.132	0.44
	BT	GFSK	Front Face	1	0	1	6	Full	77.20	14.00	12.83	0.01	0.012	1.295	1.310	0.02
P43	BT	GFSK	Rear Face	1	0	1	6	Full	77.20	14.00	12.83	0.09	0.073	1.295	1.310	0.12
	BT	GFSK	Right Side	1	0	1	6	Full	77.20	14.00	12.83	0.01	0.029	1.295	1.310	0.05
	BT	GFSK	Top Side	1	0	1	6	Full	77.20	14.00	12.83	0.03	0.043	1.295	1.310	0.07

4.6.5 SAR Results for Extremity Exposure Condition (Separation Distance is 0 cm Gap)

Plot No.	Band	Mode	Test Position	Ch.	Sample	Ant.	Power Reduction	RB#	RB Offset	Duty Cycle%	Max. Tune-up Power (dBm)	Measured Conducted Power (dBm)	Power Drift	Measured SAR-10g (W/kg)	Duty Cycle Scaling Factor	Tune-up Scaling Factor	Scaled SAR-10g (W/kg)
P44	GSM1900	GPRS 4Tx Slot	Rear Face	810	1	4	DSI2/5	-	-	-	24.50	23.10	0.02	1.430	-	1.380	1.97
	GSM1900	GPRS 4Tx Slot	Top Side	810	1	4	DSI2/5	-	-	-	24.50	23.10	0.03	1.940	-	1.380	2.68
	GSM1900	GPRS 4Tx Slot	Top Side	512	1	4	DSI2/5	-	-	-	24.50	22.87	0.04	1.470	-	1.455	2.14
	GSM1900	GPRS 4Tx Slot	Top Side	661	1	4	DSI2/5	-	-	-	24.50	22.72	0.07	1.700	-	1.507	2.56
	WCDMA II	RMC12.2K	Rear Face	9538	1	4	DSI5/2	-	-	-	22.00	20.99	0.02	2.240	-	1.262	2.83
	WCDMA II	RMC12.2K	Top Side	9538	1	4	DSI5/2	-	-	-	22.00	20.99	0.11	1.910	-	1.262	2.41
	WCDMA II	RMC12.2K	Rear Face	9262	1	4	DSI5/2	-	-	-	22.00	20.98	0.09	1.770	-	1.265	2.24
	WCDMA II	RMC12.2K	Rear Face	9400	1	4	DSI5/2	-	-	-	22.00	20.78	0.06	1.730	-	1.324	2.29
	WCDMA II	RMC12.2K	Top Side	9262	1	4	DSI5/2	-	-	-	22.00	20.98	0.05	2.010	-	1.265	2.54
P45	WCDMA II	RMC12.2K	Top Side	9400	1	4	DSI5/2	-	-	-	22.00	20.78	0.08	2.230	-	1.324	2.95
	LTE 2	QPSK20M	Rear Face	18900	1	4	DSI2	1	50	-	23.00	22.10	0.07	2.120	-	1.230	2.61
	LTE 2	QPSK20M	Top Side	18900	1	4	DSI2	1	50	-	23.00	22.10	0.02	2.400	-	1.230	2.95
	LTE 2	QPSK20M	Rear Face	18900	1	4	DSI2	50	25	-	23.00	21.55	-0.18	2.050	-	1.396	2.86
	LTE 2	QPSK20M	Top Side	18900	1	4	DSI2	50	25	-	23.00	21.55	0.03	2.430	-	1.396	3.39
	LTE 2	QPSK20M	Rear Face	18700	1	4	DSI2	1	50	-	23.00	22.02	0.17	1.790	-	1.253	2.24
	LTE 2	QPSK20M	Rear Face	19100	1	4	DSI2	1	50	-	23.00	22.07	-0.12	2.010	-	1.239	2.49
	LTE 2	QPSK20M	Top Side	18700	1	4	DSI2	1	50	-	23.00	22.02	0.04	2.380	-	1.253	2.98
	LTE 2	QPSK20M	Top Side	19100	1	4	DSI2	1	50	-	23.00	22.07	0.02	2.350	-	1.239	2.91
	LTE 2	QPSK20M	Rear Face	18700	1	4	DSI2	50	25	-	23.00	21.44	-0.07	1.780	-	1.432	2.55
	LTE 2	QPSK20M	Rear Face	19100	1	4	DSI2	50	25	-	23.00	21.54	0.08	2.160	-	1.400	3.02
P46	LTE 2	QPSK20M	Top Side	18700	1	4	DSI2	50	25	-	23.00	21.44	0.06	2.430	-	1.432	3.48
	LTE 2	QPSK20M	Top Side	19100	1	4	DSI2	50	25	-	23.00	21.54	0.07	2.420	-	1.400	3.39

Plot No.	Band	Mode	Test Position	Ch.	Sample	Ant.	Power Reduction	RB#	RB Offset	Duty Cycle%	Max. Tune-up Power (dBm)	Measured Conducted Power (dBm)	Power Drift	Measured SAR-10g (W/kg)	Duty Cycle Scaling Factor	Tune-up Scaling Factor	Scaled SAR-10g (W/kg)
	LTE 2	QPSK20M	Rear Face	18900	1	4	DSI2	100	0	-	23.00	21.49	0.03	1.600	-	1.416	2.27
	LTE 2	QPSK20M	Top Side	18900	1	4	DSI2	100	0	-	23.00	21.49	0.04	2.430	-	1.416	3.44
	LTE 2	QPSK20M	Top Side	18700	2	4	DSI2	50	25	-	23.00	21.44	0.06	2.230	-	1.432	3.19
	LTE 2	QPSK20M	Rear Face	18900	1	4	DSI5	1	50	-	22.50	21.72	0.13	1.360	-	1.197	1.63
	LTE 2	QPSK20M	Top Side	18900	1	4	DSI5	1	50	-	22.50	21.72	0.02	2.150	-	1.197	2.57
	LTE 2	QPSK20M	Rear Face	18900	1	4	DSI5	50	25	-	22.00	21.33	0.09	1.440	-	1.167	1.68
	LTE 2	QPSK20M	Top Side	18900	1	4	DSI5	50	25	-	22.00	21.33	0.05	2.180	-	1.167	2.54
	LTE 2	QPSK20M	Top Side	18700	1	4	DSI5	1	50	-	22.50	21.56	0.04	2.240	-	1.242	2.78
	LTE 2	QPSK20M	Top Side	19100	1	4	DSI5	1	50	-	22.50	21.69	0.03	2.120	-	1.205	2.55
	LTE 2	QPSK20M	Top Side	18700	1	4	DSI5	50	25	-	22.00	21.24	0.09	2.130	-	1.191	2.54
	LTE 2	QPSK20M	Top Side	19100	1	4	DSI5	50	25	-	22.00	21.28	0.02	2.150	-	1.180	2.54
	LTE 2	QPSK20M	Top Side	18900	1	4	DSI5	100	0	-	22.00	21.25	0.14	1.930	-	1.189	2.29
	LTE 66	QPSK20M	Top Side	132322	1	4	DSI5/2	1	99	-	23.00	21.96	0.09	1.950	-	1.271	2.48
	LTE 66	QPSK20M	Top Side	132322	1	4	DSI5/2	50	50	-	23.00	21.77	0.07	1.910	-	1.327	2.54
	LTE 66	QPSK20M	Top Side	132072	1	4	DSI5/2	1	99	-	23.00	21.89	0.05	1.850	-	1.291	2.39
	LTE 66	QPSK20M	Top Side	132572	1	4	DSI5/2	1	99	-	23.00	21.95	0.06	2.030	-	1.274	2.59
	LTE 66	QPSK20M	Top Side	132072	1	4	DSI5/2	50	50	-	23.00	21.75	0.08	1.830	-	1.334	2.44
P47	LTE 66	QPSK20M	Top Side	132572	1	4	DSI5/2	50	50	-	23.00	21.76	0.04	2.030	-	1.330	2.70
	LTE 66	QPSK20M	Top Side	132322	1	4	DSI5/2	100	0	-	23.00	21.69	0.05	1.760	-	1.352	2.38
P48	WLAN5G	802.11n-HT20	Rear Face	36	1	6	DSI2	-	-	98.15	17.00	16.39	0.01	0.973	1.019	1.151	1.14
	WLAN5G	802.11n-HT20	Rear Face	36	1	6	DSI5	-	-	98.15	14.00	13.04	0.00	0.432	1.019	1.247	0.55
	WLAN5G	802.11a	Front Face	60	1	6	Full	-	-	98.28	18.00	16.54	0.11	0.442	1.018	1.400	0.63
	WLAN5G	802.11a	Rear Face	60	1	6	Full	-	-	98.28	18.00	16.54	-0.09	1.370	1.018	1.400	1.95
	WLAN5G	802.11a	Right Side	60	1	6	Full	-	-	98.28	18.00	16.54	0.14	0.194	1.018	1.400	0.28
P49	WLAN5G	802.11a	Top Side	60	1	6	Full	-	-	98.28	18.00	16.54	0.02	1.510	1.018	1.400	2.15
	WLAN5G	802.11a	Top Side	52	1	6	Full	-	-	98.28	18.00	16.44	0.09	1.270	1.018	1.432	1.85
	WLAN5G	802.11a	Front Face	60	1	6	DSI5	-	-	98.28	12.00	11.21	0.13	0.154	1.018	1.199	0.19
	WLAN5G	802.11a	Rear Face	60	1	6	DSI5	-	-	98.28	12.00	11.21	0.01	0.444	1.018	1.199	0.54
	WLAN5G	802.11a	Left Side	60	1	6	DSI5	-	-	98.28	12.00	11.21	0.07	0.020	1.018	1.199	0.02
	WLAN5G	802.11a	Right Side	60	1	6	DSI5	-	-	98.28	12.00	11.21	0.16	0.069	1.018	1.199	0.08
	WLAN5G	802.11a	Top Side	60	1	6	DSI5	-	-	98.28	12.00	11.21	0.07	0.430	1.018	1.199	0.52
	WLAN5G	802.11a	Front Face	140	1	6	Full	-	-	98.28	17.50	17.01	0.05	0.165	1.018	1.120	0.19
	WLAN5G	802.11a	Rear Face	140	1	6	Full	-	-	98.28	17.50	17.01	0.02	0.387	1.018	1.120	0.44
	WLAN5G	802.11a	Right Side	140	1	6	Full	-	-	98.28	17.50	17.01	0.14	0.123	1.018	1.120	0.14
P50	WLAN5G	802.11a	Top Side	140	1	6	Full	-	-	98.28	17.50	17.01	0.01	0.401	1.018	1.120	0.46

Note :

When the hotspot SAR is adjusted for maximum tune-up tolerance and the result is <1.2W/kg, the extremity SAR is not required.

4.6.6 SAR Measurement Variability

According to KDB 865664 D01, SAR measurement variability was assessed for each frequency band, which is determined by the SAR probe calibration point and tissue-equivalent medium used for the device measurements. When both head and body tissue-equivalent media are required for SAR measurements in a frequency band, the variability measurement procedures should be applied to the tissue medium with the highest measured SAR, using the highest measured SAR configuration for that tissue-equivalent medium. Alternatively, if the highest measured SAR for both head and body tissue-equivalent media are ≤ 1.45 W/kg and the ratio of these highest SAR values, i.e., largest divided by smallest value, is ≤ 1.10 , the highest SAR configuration for either head or body tissue-equivalent medium may be used to perform the repeated measurement. These additional measurements are repeated after the completion of all measurements requiring the same head or body tissue-equivalent medium in a frequency band. The test device should be returned to ambient conditions (normal room temperature) with the battery fully charged before it is re-mounted on the device holder for the repeated measurement(s) to minimize any unexpected variations in the repeated results.

SAR repeated measurement procedure:

1. When the highest measured SAR is < 0.80 W/kg, repeated measurement is not required.
2. When the highest measured SAR is ≥ 0.80 W/kg, repeat that measurement once.
3. If the ratio of largest to smallest SAR for the original and first repeated measurements is > 1.20 , or when the original or repeated measurement is ≥ 1.45 W/kg, perform a second repeated measurement.
4. If the ratio of largest to smallest SAR for the original, first and second repeated measurements is > 1.20 , and the original, first or second repeated measurement is ≥ 1.5 W/kg, perform a third repeated measurement.

Band	Test Position	Ch.	Original Measured SAR-1g (W/kg)	1st Repeated SAR-1g (W/kg)	L/S Ratio	2nd Repeated SAR-1g (W/kg)	L/S Ratio	3rd Repeated SAR-1g (W/kg)	L/S Ratio
LTE 2	Right Tilted	18900	1.04	1.01	1.030	N/A	N/A	N/A	N/A
LTE 66	Right Tilted	132572	0.949	0.912	1.040	N/A	N/A	N/A	N/A
WLAN2.4G	Left Cheek	6	0.951	0.929	1.024	N/A	N/A	N/A	N/A
WLAN 5.2G	Left Tilted	48	0.899	0.835	1.077	N/A	N/A	N/A	N/A
WLAN 5.3G	Left Tilted	52	0.946	0.904	1.046	N/A	N/A	N/A	N/A

Band	Test Position 10mm	Ch.	Original Measured SAR-1g (W/kg)	1st Repeated SAR-1g (W/kg)	L/S Ratio	2nd Repeated SAR-1g (W/kg)	L/S Ratio	3rd Repeated SAR-1g (W/kg)	L/S Ratio
LTE 2	Rear Face	19100	0.845	0.807	1.047	N/A	N/A	N/A	N/A
LTE 66	Top Side	132322	0.670	0.641	1.045	N/A	N/A	N/A	N/A
WLAN 5.2G	Rear Face	40	0.878	0.813	1.080	N/A	N/A	N/A	N/A
WLAN 5.3G	Rear Face	60	0.992	0.917	1.082	N/A	N/A	N/A	N/A

Band	Test Position 0mm	Ch.	Original Measured SAR-10g (W/kg)	1st Repeated SAR-10g (W/kg)	L/S Ratio	2nd Repeated SAR-10g (W/kg)	L/S Ratio	3rd Repeated SAR-10g (W/kg)	L/S Ratio
LTE 2	Top Side	18700	2.43	2.35	1.034	N/A	N/A	N/A	N/A
LTE 66	Top Side	132572	2.03	1.96	1.036	N/A	N/A	N/A	N/A
WLAN 5.3G	Top Side	60	1.51	1.43	1.056	N/A	N/A	N/A	N/A

4.6.7 Simultaneous Multi-band Transmission Evaluation

<SAR Summation Analysis>

Simultaneous transmission SAR test exclusion is determined for each operating configuration and exposure condition according to the reported standalone SAR of each applicable simultaneous transmitting antenna. When the sum of SAR_{1g} of all simultaneously transmitting antennas in an operating mode and exposure condition combination is within the SAR limit (SAR_{1g} 1.6 W/kg), the simultaneous transmission SAR is not required. When the sum of SAR_{1g} is greater than the SAR limit (SAR_{1g} 1.6 W/kg), SAR test exclusion is determined by the SPLSR.

<Head Exposure condition>

WWAN Band	Exposure Position	1	2	3	4	1+2 Summed 1g SAR (W/kg)	1+3 Summed 1g SAR (W/kg)	1+4 Summed 1g SAR (W/kg)
		WWAN	2.4GHz WLAN	5GHz WLAN	BT			
		1g SAR (W/kg)	1g SAR (W/kg)	1g SAR (W/kg)	1g SAR (W/kg)			
GSM 850	Right Cheek	0.186	0.169	0.261	0.080	0.36	0.45	0.27
	Right Tilted	0.081	0.217	0.373	0.083	0.30	0.45	0.16
	Left Cheek	0.245	0.405	0.320	0.256	0.65	0.57	0.50
	Left Tilted	0.113	0.268	0.607	0.173	0.38	0.72	0.29
GSM 1900	Right Cheek	0.676	0.169	0.261	0.080	0.85	0.94	0.76
	Right Tilted	0.889	0.217	0.373	0.083	1.11	1.26	0.97
	Left Cheek	0.483	0.405	0.320	0.256	0.89	0.80	0.74
	Left Tilted	0.601	0.268	0.607	0.173	0.87	1.21	0.77
WCDMA II	Right Cheek	0.688	0.169	0.261	0.080	0.86	0.95	0.77
	Right Tilted	1.055	0.217	0.373	0.083	1.27	1.43	1.14
	Left Cheek	0.504	0.405	0.320	0.256	0.91	0.82	0.76
	Left Tilted	0.623	0.268	0.607	0.173	0.89	1.23	0.80
WCDMA V	Right Cheek	0.177	0.169	0.261	0.080	0.35	0.44	0.26
	Right Tilted	0.079	0.217	0.373	0.083	0.30	0.45	0.16
	Left Cheek	0.260	0.405	0.320	0.256	0.66	0.58	0.52
	Left Tilted	0.140	0.268	0.607	0.173	0.41	0.75	0.31
LTE 2	Right Cheek	0.938	0.169	0.261	0.080	1.11	1.20	1.02
	Right Tilted	1.040	0.217	0.373	0.083	1.26	1.41	1.12
	Left Cheek	0.616	0.405	0.320	0.256	1.02	0.94	0.87
	Left Tilted	0.725	0.268	0.607	0.173	0.99	1.33	0.90
LTE 5	Right Cheek	0.147	0.169	0.261	0.080	0.32	0.41	0.23
	Right Tilted	0.101	0.217	0.373	0.083	0.32	0.47	0.18
	Left Cheek	0.207	0.405	0.320	0.256	0.61	0.53	0.46
	Left Tilted	0.119	0.268	0.607	0.173	0.39	0.73	0.29
LTE 12	Right Cheek	0.100	0.169	0.261	0.080	0.27	0.36	0.18
	Right Tilted	0.064	0.217	0.373	0.083	0.28	0.44	0.15
	Left Cheek	0.130	0.405	0.320	0.256	0.54	0.45	0.39
	Left Tilted	0.083	0.268	0.607	0.173	0.35	0.69	0.26
LTE 13	Right Cheek	0.132	0.169	0.261	0.080	0.30	0.39	0.21
	Right Tilted	0.096	0.217	0.373	0.083	0.31	0.47	0.18
	Left Cheek	0.128	0.405	0.320	0.256	0.53	0.45	0.38
	Left Tilted	0.127	0.268	0.607	0.173	0.40	0.73	0.30

WWAN Band	Exposure Position	1	2	3	4	1+2 Summed 1g SAR (W/kg)	1+3 Summed 1g SAR (W/kg)	1+4 Summed 1g SAR (W/kg)
		WWAN	2.4GHz WLAN	5GHz WLAN	BT			
		1g SAR (W/kg)	1g SAR (W/kg)	1g SAR (W/kg)	1g SAR (W/kg)			
LTE 66	Right Cheek	0.698	0.169	0.261	0.080	0.87	0.96	0.78
	Right Tilted	0.737	0.217	0.373	0.083	0.95	1.11	0.82
	Left Cheek	0.503	0.405	0.320	0.256	0.91	0.82	0.76
	Left Tilted	0.637	0.268	0.607	0.173	0.91	1.24	0.81

<Body Worn Exposure condition>

WWAN Band	Exposure Position	1	2	3	4	1+2 Summed 1g SAR (W/kg)	1+3 Summed 1g SAR (W/kg)	1+4 Summed 1g SAR (W/kg)
		WWAN	2.4GHz WLAN	5GHz WLAN	BT			
		1g SAR (W/kg)	1g SAR (W/kg)	1g SAR (W/kg)	1g SAR (W/kg)			
GSM 850	Front at 1.0cm	0.184	0.150	0.124	0.020	0.33	0.31	0.20
	Back at 1.0cm	0.317	0.396	0.452	0.123	0.71	0.77	0.44
GSM 1900	Front at 1.0cm	0.316	0.150	0.124	0.020	0.47	0.44	0.34
	Back at 1.0cm	0.584	0.396	0.452	0.123	0.98	1.04	0.71
	Front at 1.1cm	0.457	0.150	0.239	0.020	0.61	0.70	0.48
	Back at 2.2cm	0.230	0.396	0.582	0.123	0.63	0.81	0.35
WCDMA II	Front at 1.0cm	0.366	0.150	0.124	0.020	0.52	0.49	0.39
	Back at 1.0cm	0.925	0.396	0.452	0.123	1.32	1.38	1.05
	Front at 1.1cm	0.763	0.150	0.239	0.020	0.91	1.00	0.78
	Back at 2.2cm	0.353	0.396	0.582	0.123	0.75	0.94	0.48
WCDMA V	Front at 1.0cm	0.203	0.150	0.124	0.020	0.35	0.33	0.22
	Back at 1.0cm	0.343	0.396	0.452	0.123	0.74	0.79	0.47
LTE 2	Front at 1.0cm	0.436	0.150	0.124	0.020	0.59	0.56	0.46
	Back at 1.0cm	0.944	0.396	0.452	0.123	1.34	1.40	1.07
	Front at 1.1cm	0.694	0.150	0.239	0.020	0.84	0.93	0.71
	Back at 2.2cm	0.371	0.396	0.582	0.123	0.77	0.95	0.49
LTE 5	Front at 1.0cm	0.175	0.150	0.124	0.020	0.32	0.30	0.19
	Back at 1.0cm	0.411	0.396	0.452	0.123	0.81	0.86	0.53
LTE 12	Front at 1.0cm	0.178	0.150	0.124	0.020	0.33	0.30	0.20
	Back at 1.0cm	0.235	0.396	0.452	0.123	0.63	0.69	0.36

WWAN Band	Exposure Position	1	2	3	4	1+2 Summed 1g SAR (W/kg)	1+3 Summed 1g SAR (W/kg)	1+4 Summed 1g SAR (W/kg)
		WWAN	2.4GHz WLAN	5GHz WLAN	BT			
LTE 13	Front at 1.0cm	0.201	0.150	0.124	0.020	0.35	0.33	0.22
	Back at 1.0cm	0.233	0.396	0.452	0.123	0.63	0.68	0.36
LTE 66	Front at 1.0cm	0.384	0.150	0.124	0.020	0.53	0.51	0.40
	Back at 1.0cm	0.651	0.396	0.452	0.123	1.05	1.10	0.77
	Front at 1.1cm	0.452	0.150	0.239	0.020	0.60	0.69	0.47
	Back at 2.2cm	0.209	0.396	0.582	0.123	0.60	0.79	0.33

<Hotspot Exposure condition>

WWAN Band	Exposure Position	1	2	3	4	1+2 Summed 1g SAR (W/kg)	1+3 Summed 1g SAR (W/kg)	1+4 Summed 1g SAR (W/kg)
		WWAN	2.4GHz WLAN	5GHz WLAN	BT			
		1g SAR (W/kg)	1g SAR (W/kg)	1g SAR (W/kg)	1g SAR (W/kg)			
GSM 850	Front at 1.0cm	0.184	0.229	0.180	0.020	0.41	0.36	0.20
	Back at 1.0cm	0.317	0.568	0.498	0.123	0.89	0.82	0.44
	Left side at 1.0cm	0.288				0.29	0.29	0.29
	Right side at 1.0cm	0.000	0.235	0.220	0.049	0.24	0.22	0.05
	Top side at 1.0cm		0.332	0.437	0.073	0.33	0.44	0.07
	Bottom side at 1.0cm	0.095				0.10	0.10	0.10
GSM 1900	Front at 1.0cm	0.300	0.229	0.180	0.020	0.53	0.48	0.32
	Back at 1.0cm	0.670	0.568	0.498	0.123	1.24	1.17	0.79
	Left side at 1.0cm	0.139				0.14	0.14	0.14
	Right side at 1.0cm	0.000	0.235	0.220	0.049	0.24	0.22	0.05
	Top side at 1.0cm	0.845	0.332	0.437	0.073	1.18	1.28	0.92
	Bottom side at 1.0cm					0.00	0.00	0.00
	Top side at 1.9cm	0.517	0.332	0.437	0.073	0.85	0.95	0.59
WCDMA II	Front at 1.0cm	0.280	0.229	0.180	0.020	0.51	0.46	0.30
	Back at 1.0cm	0.591	0.568	0.498	0.123	1.16	1.09	0.71
	Left side at 1.0cm	0.134				0.13	0.13	0.13
	Right side at 1.0cm	0.000	0.235	0.220	0.049	0.24	0.22	0.05
	Top side at 1.0cm	0.723	0.332	0.437	0.073	1.06	1.16	0.80
	Bottom side at 1.0cm					0.00	0.00	0.00
	Top side at 1.9cm	0.914	0.332	0.437	0.073	1.25	1.35	0.99
WCDMA V	Front at 1.0cm	0.203	0.229	0.180	0.020	0.43	0.38	0.22
	Back at 1.0cm	0.343	0.568	0.498	0.123	0.91	0.84	0.47
	Left side at 1.0cm	0.317				0.32	0.32	0.32
	Right side at 1.0cm	0.000	0.235	0.220	0.049	0.24	0.22	0.05
	Top side at 1.0cm		0.332	0.437	0.073	0.33	0.44	0.07
	Bottom side at 1.0cm	0.115				0.12	0.12	0.12
LTE 2	Front at 1.0cm	0.447	0.229	0.180	0.020	0.68	0.63	0.47

WWAN Band	Exposure Position	1	2	3	4	1+2 Summed 1g SAR (W/kg)	1+3 Summed 1g SAR (W/kg)	1+4 Summed 1g SAR (W/kg)
		WWAN	2.4GHz WLAN	5GHz WLAN	BT			
		1g SAR (W/kg)	1g SAR (W/kg)	1g SAR (W/kg)	1g SAR (W/kg)			
	Back at 1.0cm	0.692	0.568	0.498	0.123	1.26	1.19	0.82
	Left side at 1.0cm	0.167				0.17	0.17	0.17
	Right side at 1.0cm	0.000	0.235	0.220	0.049	0.24	0.22	0.05
	Top side at 1.0cm	0.874	0.332	0.437	0.073	1.21	1.31	0.95
	Bottom side at 1.0cm					0.00	0.00	0.00
	Top side at 1.9cm	0.781	0.332	0.437	0.073	1.11	1.22	0.85
LTE 5	Front at 1.0cm	0.175	0.229	0.180	0.020	0.40	0.35	0.19
	Back at 1.0cm	0.411	0.568	0.498	0.123	0.98	0.91	0.53
	Left side at 1.0cm	0.230				0.23	0.23	0.23
	Right side at 1.0cm	0.000	0.235	0.220	0.049	0.24	0.22	0.05
	Top side at 1.0cm		0.332	0.437	0.073	0.33	0.44	0.07
	Bottom side at 1.0cm	0.138				0.14	0.14	0.14
LTE 12	Front at 1.0cm	0.178	0.229	0.180	0.020	0.41	0.36	0.20
	Back at 1.0cm	0.235	0.568	0.498	0.123	0.80	0.73	0.36
	Left side at 1.0cm	0.222				0.22	0.22	0.22
	Right side at 1.0cm	0.000	0.235	0.220	0.049	0.24	0.22	0.05
	Top side at 1.0cm		0.332	0.437	0.073	0.33	0.44	0.07
	Bottom side at 1.0cm	0.103				0.10	0.10	0.10
LTE 13	Front at 1.0cm	0.201	0.229	0.180	0.020	0.43	0.38	0.22
	Back at 1.0cm	0.233	0.568	0.498	0.123	0.80	0.73	0.36
	Left side at 1.0cm	0.219				0.22	0.22	0.22
	Right side at 1.0cm	0.000	0.235	0.220	0.049	0.24	0.22	0.05
	Top side at 1.0cm		0.332	0.437	0.073	0.33	0.44	0.07
	Bottom side at 1.0cm	0.135				0.14	0.14	0.14
LTE 66	Front at 1.0cm	0.401	0.229	0.180	0.020	0.63	0.58	0.42
	Back at 1.0cm	0.722	0.568	0.498	0.123	1.29	1.22	0.85
	Left side at 1.0cm	0.222				0.22	0.22	0.22
	Right side at 1.0cm	0.000	0.235	0.220	0.049	0.24	0.22	0.05
	Top side at 1.0cm	0.871	0.332	0.437	0.073	1.20	1.31	0.94
	Bottom side at 1.0cm					0.00	0.00	0.00
	Top side at 1.9cm	0.422	0.332	0.437	0.073	0.75	0.86	0.49

<Extremity Exposure condition>

WWAN Band	Exposure Position	1	2	1+2 Summed 10g SAR (W/kg)
		WWAN	5GHz WLAN	
		10g SAR (W/kg)	10g SAR (W/kg)	
GSM 1900	Front at 0cm		0.188	0.19
	Back at 0cm	1.974	0.549	2.52

WWAN Band	Exposure Position	1	2	1+2 Summed 10g SAR (W/kg)
		WWAN	5GHz WLAN	
	Left side at 0cm			0.00
	Right side at 0cm		0.140	0.14
	Top side at 0cm	2.678	0.525	3.20
	Bottom side at 0cm			0.00
WCDMA II	Front at 0cm		0.188	0.19
	Back at 0cm	2.826	0.549	3.38
	Left side at 0cm			0.00
	Right side at 0cm		0.140	0.14
	Top side at 0cm	2.953	0.525	3.48
	Bottom side at 0cm			0.00
LTE 2	Front at 0cm		0.188	0.19
	Back at 0cm	1.680	0.549	2.23
	Left side at 0cm			0.00
	Right side at 0cm		0.140	0.14
	Top side at 0cm	2.781	0.525	3.31
	Bottom side at 0cm			0.00
LTE 66	Front at 0cm		0.188	0.19
	Back at 0cm		0.549	0.55
	Left side at 0cm			0.00
	Right side at 0cm		0.140	0.14
	Top side at 0cm	2.701	0.525	3.23
	Bottom side at 0cm			0.00

Note:

1. The SAR summation of maximum SAR of WWAN and WLAN/BT for each position is under the SAR limitation (**Head & Body: SAR1g 1.6 W/kg, Extremity: SAR10g 4.0 W/kg**). Therefore, the simultaneous transmission condition is compliance with the SAR criterion.

Test Engineer : Chang Gao, and Zixiao Xia.

5. Calibration of Test Equipment

Equipment	Manufacturer	Model	SN	Cal. Date	Cal. Interval
System Validation Dipole	SPEAG	D750V3	1200	Oct. 27, 2021	3 Years
System Validation Dipole	SPEAG	D835V2	4d265	Oct. 18, 2021	3 Years
System Validation Dipole	SPEAG	D1750V2	1176	Oct. 19, 2021	3 Years
System Validation Dipole	SPEAG	D1900V2	5d159	Sep. 16, 2021	3 Years
System Validation Dipole	SPEAG	D2450V2	1048	Oct. 21, 2021	3 Years
System Validation Dipole	SPEAG	D5GHzV2	1315	Oct. 22, 2021	3 Years
Data Acquisition Electronics	SPEAG	DAE4	755	Mar. 23, 2023	1 Year
Dosimetric E-field Probe	SPEAG	EX3DV4	3985	Jul. 10, 2023	1 Year
Vector Network Analyzer	SPEAG	VNA R140	0121219	Feb. 17, 2023	1 Year
dielectric parameter probes	SPEAG	DAK-3.5	1119	Feb. 20, 2023	1 Year
Wideband Radio Communication Tester	Rohde&Schwarz	CMW 500	169210	Jun. 27, 2022	2 Year
Power Meter	Rohde&Schwarz	NRX	NRX	Feb. 14, 2022	2 Year
Power Sensor	Rohde&Schwarz	NRP6A	NRP6A	Feb. 14, 2022	2 Year
Power Sensor	Rohde&Schwarz	NRP6A	NRP6A	Feb. 14, 2022	2 Year
ESG Analog Signal Generator	Rohde&Schwarz	SMB100A03	SMB100A03	Feb. 15, 2022	2 Year
Coupler	Woken	0110A056020-10	COM27RW1A3	May. 10, 2023	1 Year
Temp.&Humi.Recorder	ANYMETRE	JR912	SZ01	Jun. 19, 2022	2 Year

Note:

- Referring to KDB 865664 D01 v01r04, the dipole calibration interval can be extended to 3 years with justification. The dipole are also not physically damaged, or repaired during the interval. The dipole justification can be found in appendix C.
The return loss is $< -20\text{dB}$, within 20% of prior calibration, the impedance is with 5ohm of prior calibration.

6. Measurement Uncertainty

DASY6 Uncertainty Budget According to IEEE 1528-2013 and IEC 62209-1/2016 (0.3 - 3 GHz range)								
Error Description	Uncertainty Value (±%)	Probability	Divisor	(Ci) 1g	(Ci) 10g	Standard Uncertainty (1g) (±%)	Standard Uncertainty (10g) (±%)	(Vi) Veff
Measurement System								
Probe Calibration	6.05	N	1	1	1	6.1	6.1	∞
Axial Isotropy	4.7	R	1.732	0.7	0.7	1.9	1.9	∞
Hemispherical Isotropy	9.6	R	1.732	0.7	0.7	3.9	3.9	∞
Boundary Effects	2.0	R	1.732	1	1	1.2	1.2	∞
Linearity	4.7	R	1.732	1	1	2.7	2.7	∞
System Detection Limits	1.0	R	1.732	1	1	0.6	0.6	∞
Modulation Response	3.2	R	1.732	1	1	1.8	1.8	∞
Readout Electronics	0.3	N	1	1	1	0.3	0.3	∞
Response Time	0.0	R	1.732	1	1	0.0	0.0	∞
Integration Time	2.6	R	1.732	1	1	1.5	1.5	∞
RF Ambient Noise	3.0	R	1.732	1	1	1.7	1.7	∞
RF Ambient Reflections	3.0	R	1.732	1	1	1.7	1.7	∞
Probe Positioner	0.4	R	1.732	1	1	0.2	0.2	∞
Probe Positioning	6.7	R	1.732	1	1	3.9	3.9	∞
Max. SAR Eval.	4.0	R	1.732	1	1	2.3	2.3	∞
Test Sample Related								
Device Positioning	4.0	N	1	1	1	4.0	4.0	35
Device Holder	4.9	N	1	1	1	4.9	4.9	12
Power Drift	5.0	R	1.732	1	1	2.9	2.9	∞
Power Scaling	0.0	R	1.732	1	1	0.0	0.0	∞
Phantom and Setup								
Phantom Uncertainty	6.6	R	1.732	1	1	3.8	3.8	∞
SAR correction	0.0	R	1.732	1	0.84	0.0	0.0	∞
Liquid Conductivity Repeatability	0.14	N	1	0.78	0.71	0.1	0.1	5
Liquid Conductivity (target)	10.0	R	1.732	0.78	0.71	4.5	4.1	∞
Liquid Conductivity (mea.)	2.5	R	1.732	0.78	0.71	1.1	1.0	∞
Temp. unc. - Conductivity	2.61	R	1.732	0.78	0.71	1.2	1.1	∞
Liquid Permittivity Repeatability	0.03	N	1	0.23	0.26	0.0	0.0	5
Liquid Permittivity (target)	10.0	R	1.732	0.23	0.26	1.3	1.5	∞
Liquid Permittivity (mea.)	2.5	R	1.732	0.23	0.26	0.3	0.4	∞
Temp. unc. - Permittivity	1.78	R	1.732	0.23	0.26	0.2	0.3	∞
Combined Std. Uncertainty						13.6%	13.5%	578
Coverage Factor for 95 %						K=2	K=2	
Expanded STD Uncertainty						27.2%	26.9%	

Uncertainty budget for frequency range 300 MHz to 3 GHz

DASY6 Uncertainty Budget According to IEC 62209-2/2010 (30 MHz - 6 GHz range)								
Error Description	Uncertainty Value (±%)	Probability	Divisor	(Ci) 1g	(Ci) 10g	Standard Uncertainty (1g) (±%)	Standard Uncertainty (10g) (±%)	(Vi) Veff
Measurement System								
Probe Calibration	6.65	N	1	1	1	6.7	6.7	∞
Axial Isotropy	4.7	R	1.732	0.7	0.7	1.9	1.9	∞
Hemispherical Isotropy	9.6	R	1.732	0.7	0.7	3.9	3.9	∞
Boundary Effects	2.0	R	1.732	1	1	1.2	1.2	∞
Linearity	4.7	R	1.732	1	1	2.7	2.7	∞
System Detection Limits	1.0	R	1.732	1	1	0.6	0.6	∞
Modulation Response	3.2	R	1.732	1	1	1.8	1.8	∞
Readout Electronics	0.3	N	1	1	1	0.3	0.3	∞
Response Time	0.0	R	1.732	1	1	0.0	0.0	∞
Integration Time	2.6	R	1.732	1	1	1.5	1.5	∞
RF Ambient Noise	3.0	R	1.732	1	1	1.7	1.7	∞
RF Ambient Reflections	3.0	R	1.732	1	1	1.7	1.7	∞
Probe Positioner	0.4	R	1.732	1	1	0.2	0.2	∞
Probe Positioning	6.7	R	1.732	1	1	3.9	3.9	∞
Max. SAR Eval.	4.0	R	1.732	1	1	2.3	2.3	∞
Test Sample Related								
Device Positioning	4.3	N	1	1	1	4.3	4.3	35
Device Holder	4.9	N	1	1	1	4.9	4.9	12
Power Drift	5.0	R	1.732	1	1	2.9	2.9	∞
Power Scaling	0.0	R	1.732	1	1	0.0	0.0	∞
Phantom and Setup								
Phantom Uncertainty	6.6	R	1.732	1	1	3.8	3.8	∞
SAR correction	0.0	R	1.732	1	0.84	0.0	0.0	∞
Liquid Conductivity Repeatability	0.16	N	1	0.78	0.71	0.1	0.1	5
Liquid Conductivity (target)	10.0	R	1.732	0.78	0.71	4.5	4.1	∞
Liquid Conductivity (mea.)	2.5	R	1.732	0.78	0.71	1.1	1.0	∞
Temp. unc. - Conductivity	3.64	R	1.732	0.78	0.71	1.6	1.5	∞
Liquid Permittivity Repeatability	0.08	N	1	0.23	0.26	0.0	0.0	5
Liquid Permittivity (target)	10.0	R	1.732	0.23	0.26	1.3	1.5	∞
Liquid Permittivity (mea.)	2.5	R	1.732	0.23	0.26	0.3	0.4	∞
Temp. unc. - Permittivity	1.78	R	1.732	0.23	0.26	0.2	0.3	∞
Combined Std. Uncertainty						14.0%	13.9%	624
Coverage Factor for 95 %						K=2	K=2	
Expanded STD Uncertainty						28.0%	27.7%	

Uncertainty budget for frequency range 30 MHz to 6 GHz

7. Information on the Testing Laboratories

We, Huarui Saiwei (Suzhou) Technology Co., LTD., were founded in 2020 to provide our best service in EMC, Radio, Telecom and Safety consultation.

If you have any comments, please feel free to contact us at the following:

Add: Tower N, Innovation Center, 88 Zuyi Road, High-tech District, Suzhou City, Anhui Province

Tel: [+86 \(0557\) 368 1008](tel:+86(0557)3681008)

The road map of all our labs can be found in our web site also

Web: <http://www.7Layers.com>

---END---

Appendix A. SAR Plots of System Verification

The plots for system verification with largest deviation for each SAR system combination are shown as follows.

System Check_HSL750_240112

DUT: Dipole 750 MHz; Type: D750V3

Communication System: CW; Frequency: 750 MHz; Duty Cycle: 1:1

Medium: HSL750_0112 Medium parameters used: $f = 750$ MHz; $\sigma = 0.908$ S/m; $\epsilon_r = 42.869$; $\rho = 1000$ kg/m³

Ambient Temperature : 23.4°C; Liquid Temperature : 22.5°C

DASY5 Configuration:

- Probe: EX3DV4 - SN3985; ConvF(10.3, 10.3, 10.3) @ 750 MHz; Calibrated: 2023/07/10
- Sensor-Surface: 2mm (Mechanical Surface Detection)
- Electronics: DAE4 Sn755; Calibrated: 2023/03/23
- Phantom: SAM Right ; Type: QD000P40CD; Serial: TP:1502
- Measurement SW: DASY52, Version 52.8 (8); SEMCAD X Version 14.6.14 (7483)

Pin=250mW/Area Scan (61x141x1): Interpolated grid: dx=1.500 mm, dy=1.500 mm
Maximum value of SAR (interpolated) = 2.33 W/kg

Pin=250mW/Zoom Scan (5x5x7)/Cube 0: Measurement grid: dx=8mm, dy=8mm, dz=5mm

Reference Value = 52.50 V/m; Power Drift = -0.05 dB

Peak SAR (extrapolated) = 3.63 W/kg

SAR(1 g) = 2.17 W/kg; SAR(10 g) = 1.42 W/kg

Smallest distance from peaks to all points 3 dB below = 22.6 mm

Ratio of SAR at M2 to SAR at M1 = 65.7%

Maximum value of SAR (measured) = 2.34 W/kg

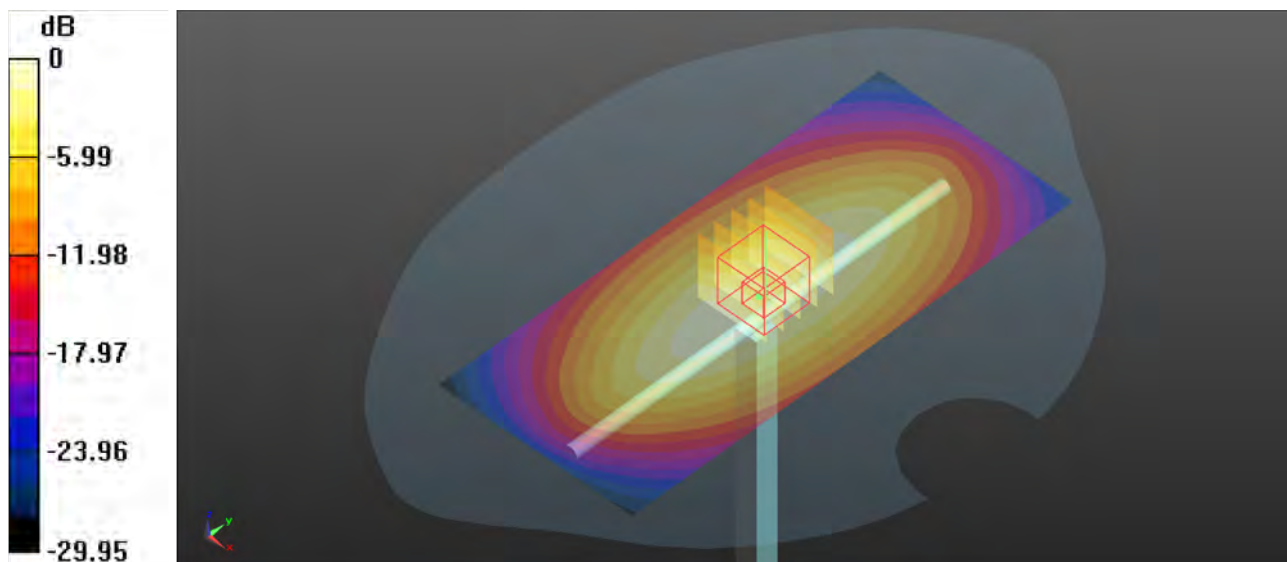

0 dB = 2.34 W/kg

System Check_HSL835_240111

DUT: Dipole 835 MHz; Type: D835V2

Communication System: CW; Frequency: 835 MHz; Duty Cycle: 1:1

Medium: HSL835_0111 Medium parameters used: $f = 835$ MHz; $\sigma = 0.944$ S/m; $\epsilon_r = 42.985$; $\rho = 1000$ kg/m³

Ambient Temperature : 23.3°C; Liquid Temperature : 22.6°C

DASY5 Configuration:

- Probe: EX3DV4 - SN3985; ConvF(9.9, 9.9, 9.9) @ 835 MHz; Calibrated: 2023/07/10
- Sensor-Surface: 2mm (Mechanical Surface Detection)
- Electronics: DAE4 Sn755; Calibrated: 2023/03/23
- Phantom: SAM Right ; Type: QD000P40CD; Serial: TP:1502
- Measurement SW: DASY52, Version 52.8 (8); SEMCAD X Version 14.6.14 (7483)

Pin=250mW/Area Scan (71x141x1): Interpolated grid: dx=1.500 mm, dy=1.500 mm
Maximum value of SAR (interpolated) = 2.73 W/kg

Pin=250mW/Zoom Scan (5x5x7)/Cube 0: Measurement grid: dx=8mm, dy=8mm, dz=5mm

Reference Value = 52.56 V/m; Power Drift = 0.03 dB

Peak SAR (extrapolated) = 3.72 W/kg

SAR(1 g) = 2.48 W/kg; SAR(10 g) = 1.61 W/kg

Smallest distance from peaks to all points 3 dB below = 19.5 mm

Ratio of SAR at M2 to SAR at M1 = 66.7%

Maximum value of SAR (measured) = 2.72 W/kg

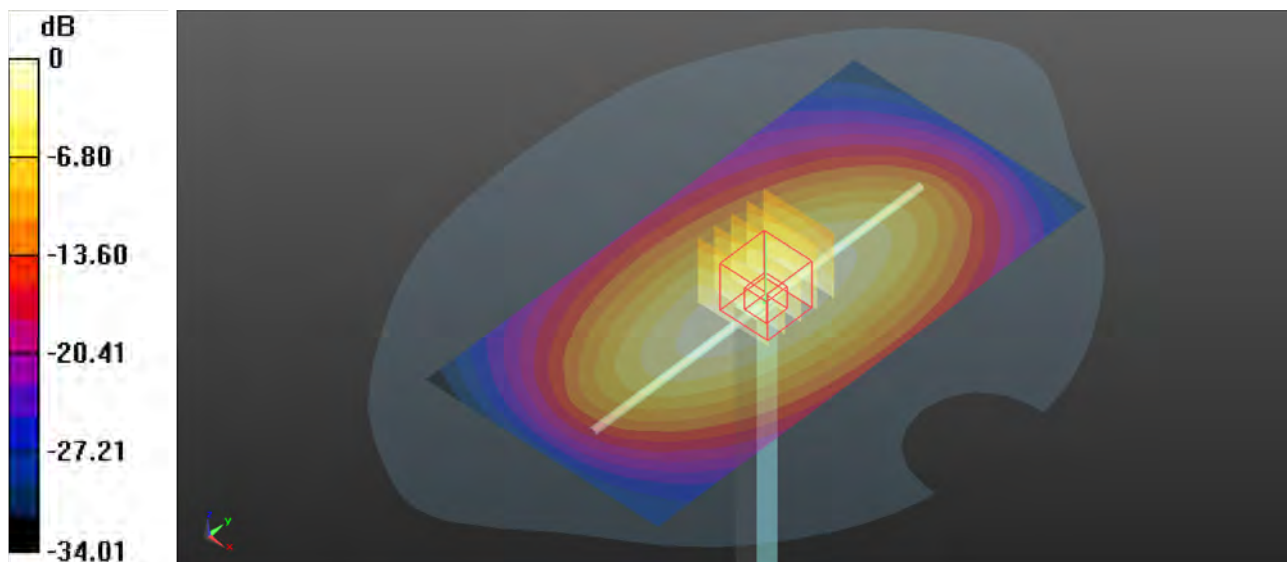

0 dB = 2.72 W/kg

System Check_HSL1750_240124

DUT: Dipole 1750 MHz; Type: D1750V2

Communication System: CW; Frequency: 1750 MHz; Duty Cycle: 1:1

Medium: HSL1750_0124 Medium parameters used: $f = 1750$ MHz; $\sigma = 1.367$ S/m; $\epsilon_r = 40.389$; $\rho = 1000$ kg/m³

Ambient Temperature : 23.3°C; Liquid Temperature : 22.4°C

DASY5 Configuration:

- Probe: EX3DV4 - SN3985; ConvF(8.53, 8.53, 8.53) @ 1750 MHz; Calibrated: 2023/07/10
- Sensor-Surface: 2mm (Mechanical Surface Detection)
- Electronics: DAE4 Sn755; Calibrated: 2023/03/23
- Phantom: SAM Right ; Type: QD000P40CD; Serial: TP:1502
- Measurement SW: DASY52, Version 52.8 (8); SEMCAD X Version 14.6.14 (7483)

Pin=250mW/Area Scan (81x81x1): Interpolated grid: dx=1.500 mm, dy=1.500 mm

Maximum value of SAR (interpolated) = 10.2 W/kg

Pin=250mW/Zoom Scan (5x5x7)/Cube 0: Measurement grid: dx=8mm, dy=8mm, dz=5mm

Reference Value = 84.78 V/m; Power Drift = 0.02 dB

Peak SAR (extrapolated) = 16.3 W/kg

SAR(1 g) = 8.98 W/kg; SAR(10 g) = 4.75 W/kg

Smallest distance from peaks to all points 3 dB below = 11.6 mm

Ratio of SAR at M2 to SAR at M1 = 56.7%

Maximum value of SAR (measured) = 10.2 W/kg

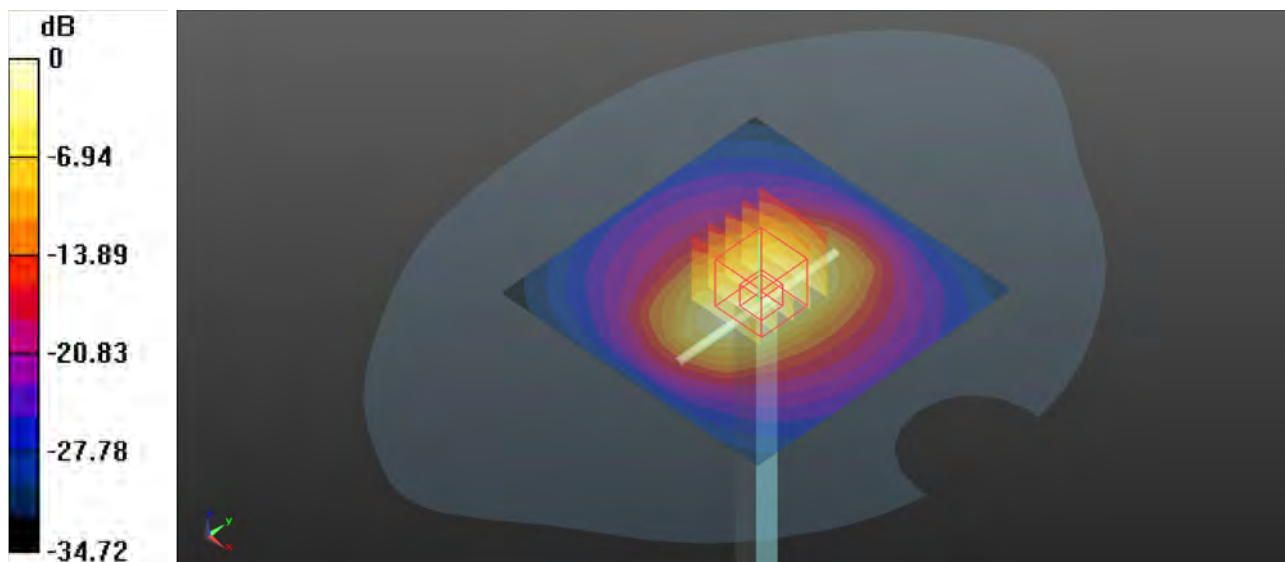

0 dB = 10.2 W/kg

System Check_HSL1950_240122

DUT: Dipole 1950 MHz; Type: D1950V3

Communication System: CW; Frequency: 1950 MHz; Duty Cycle: 1:1

Medium: HSL1950_0122 Medium parameters used: $f = 1950$ MHz; $\sigma = 1.469$ S/m; $\epsilon_r = 39.423$; $\rho = 1000$ kg/m³

Ambient Temperature : 23.5°C; Liquid Temperature : 22.6°C

DASY5 Configuration:

- Probe: EX3DV4 - SN3985; ConvF(8.26, 8.26, 8.26) @ 1950 MHz; Calibrated: 2023/07/10
- Sensor-Surface: 2mm (Mechanical Surface Detection)
- Electronics: DAE4 Sn755; Calibrated: 2023/03/23
- Phantom: SAM Right ; Type: QD000P40CD; Serial: TP:1502
- Measurement SW: DASY52, Version 52.8 (8); SEMCAD X Version 14.6.14 (7483)

Pin=250mW/Area Scan (71x71x1): Interpolated grid: dx=1.500 mm, dy=1.500 mm

Maximum value of SAR (interpolated) = 12.5 W/kg

Pin=250mW/Zoom Scan (5x5x7)/Cube 0: Measurement grid: dx=8mm, dy=8mm, dz=5mm

Reference Value = 86.30 V/m; Power Drift = 0.11 dB

Peak SAR (extrapolated) = 21.5 W/kg

SAR(1 g) = 10.3 W/kg; SAR(10 g) = 5.14 W/kg

Smallest distance from peaks to all points 3 dB below = 11.2 mm

Ratio of SAR at M2 to SAR at M1 = 53.1%

Maximum value of SAR (measured) = 12.1 W/kg

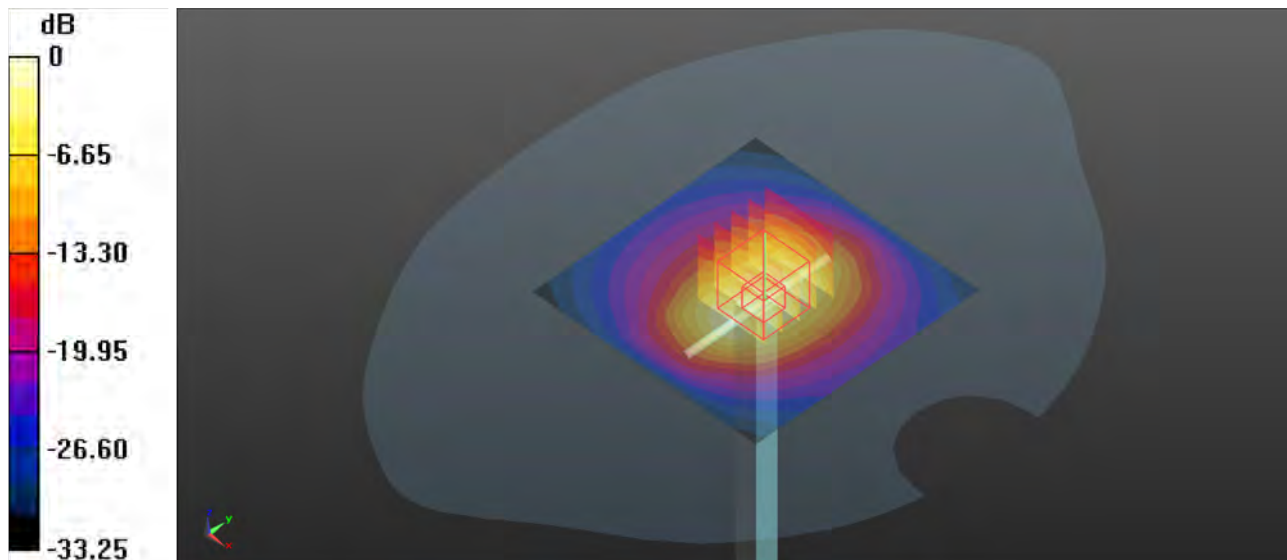

0 dB = 12.1 W/kg

System Check_HSL1950_240123

DUT: Dipole 1950 MHz; Type: D1950V3

Communication System: CW; Frequency: 1950 MHz; Duty Cycle: 1:1

Medium: HSL1950_0123 Medium parameters used: $f = 1950$ MHz; $\sigma = 1.462$ S/m; $\epsilon_r = 39.368$; $\rho = 1000$ kg/m³

Ambient Temperature : 23.1°C; Liquid Temperature : 22.3°C

DASY5 Configuration:

- Probe: EX3DV4 - SN3985; ConvF(8.26, 8.26, 8.26) @ 1950 MHz; Calibrated: 2023/07/10
- Sensor-Surface: 2mm (Mechanical Surface Detection)
- Electronics: DAE4 Sn755; Calibrated: 2023/03/23
- Phantom: SAM Right ; Type: QD000P40CD; Serial: TP:1502
- Measurement SW: DASY52, Version 52.8 (8); SEMCAD X Version 14.6.14 (7483)

Pin=250mW/Area Scan (41x71x1): Interpolated grid: dx=1.500 mm, dy=1.500 mm

Maximum value of SAR (interpolated) = 12.8 W/kg

Pin=250mW/Zoom Scan (5x5x7)/Cube 0: Measurement grid: dx=8mm, dy=8mm, dz=5mm

Reference Value = 86.81 V/m; Power Drift = 0.12 dB

Peak SAR (extrapolated) = 19.3 W/kg

SAR(1 g) = 10.4 W/kg; SAR(10 g) = 5.18 W/kg

Smallest distance from peaks to all points 3 dB below = 11.2 mm

Ratio of SAR at M2 to SAR at M1 = 55.2%

Maximum value of SAR (measured) = 11.7 W/kg

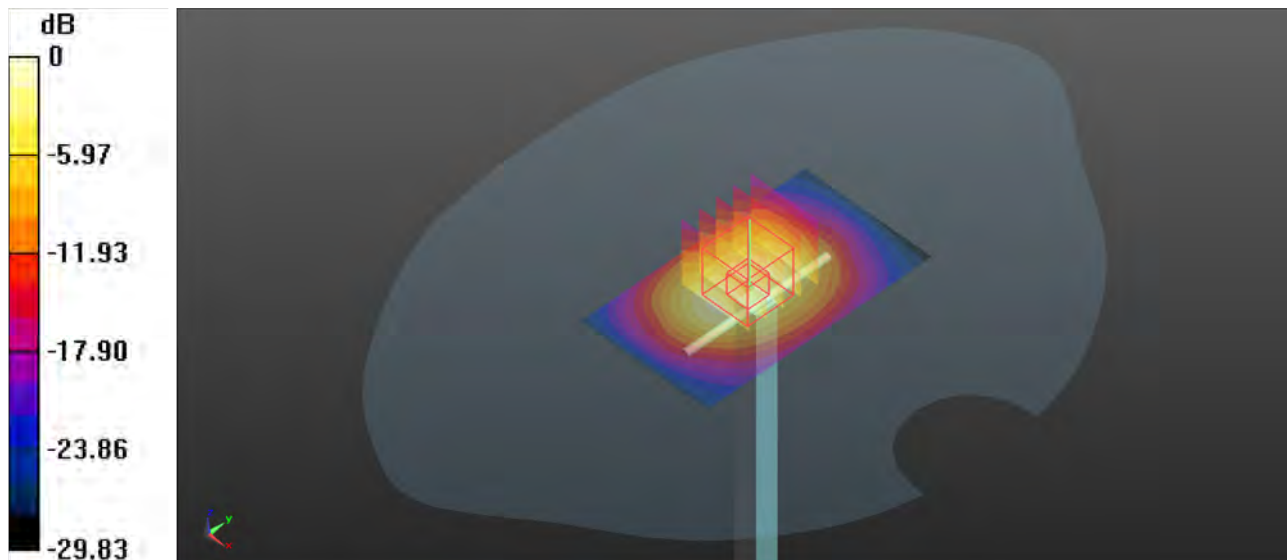

0 dB = 11.7 W/kg

System Check_HSL2450_240113

DUT: Dipole 2450 MHz; Type: D2450V2

Communication System: CW; Frequency: 2450 MHz; Duty Cycle: 1:1

Medium: HSL2450_0113 Medium parameters used: $f = 2450$ MHz; $\sigma = 1.879$ S/m; $\epsilon_r = 39.63$; $\rho = 1000$ kg/m³

Ambient Temperature : 23.2°C; Liquid Temperature : 22.7°C

DASY5 Configuration:

- Probe: EX3DV4 - SN3985; ConvF(7.8, 7.8, 7.8) @ 2450 MHz; Calibrated: 2023/07/10
- Sensor-Surface: 2mm (Mechanical Surface Detection)
- Electronics: DAE4 Sn755; Calibrated: 2023/03/23
- Phantom: SAM Right ; Type: QD000P40CD; Serial: TP:1502
- Measurement SW: DASY52, Version 52.8 (8); SEMCAD X Version 14.6.14 (7483)

Pin=250mW/Area Scan (81x81x1): Interpolated grid: dx=1.200 mm, dy=1.200 mm

Maximum value of SAR (interpolated) = 15.5 W/kg

Pin=250mW/Zoom Scan (7x7x7)/Cube 0: Measurement grid: dx=5mm, dy=5mm, dz=5mm

Reference Value = 83.43 V/m; Power Drift = -0.04 dB

Peak SAR (extrapolated) = 26.1 W/kg

SAR(1 g) = 13.1 W/kg; SAR(10 g) = 6.11 W/kg

Smallest distance from peaks to all points 3 dB below = 10.2 mm

Ratio of SAR at M2 to SAR at M1 = 49.9%

Maximum value of SAR (measured) = 15.1 W/kg

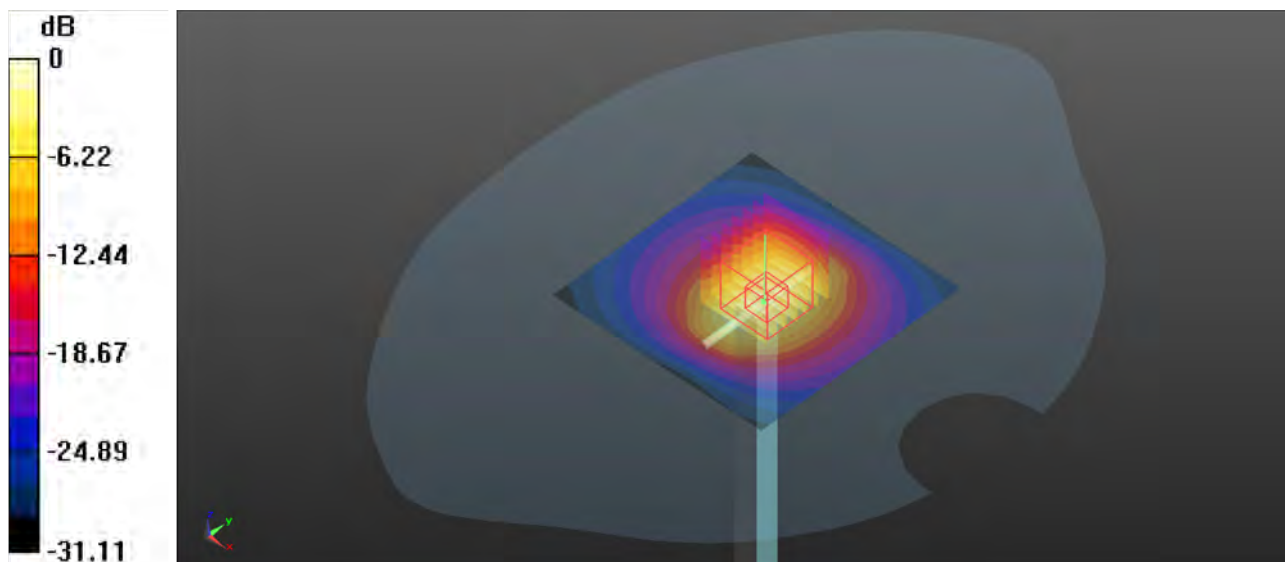

0 dB = 15.1 W/kg

System Check_HSL5250_240125

DUT: Dipole 5GHz; Type: D5GHzV2

Communication System: CW; Frequency: 5250 MHz; Duty Cycle: 1:1

Medium: HSL5G_0125 Medium parameters used: $f = 5250$ MHz; $\sigma = 4.562$ S/m; $\epsilon_r = 35.208$; $\rho = 1000$ kg/m³

Ambient Temperature : 23.7°C; Liquid Temperature : 22.5°C

DASY5 Configuration:

- Probe: EX3DV4 - SN3985; ConvF(5.6, 5.6, 5.6) @ 5250 MHz; Calibrated: 2023/07/10
- Sensor-Surface: 2mm (Mechanical Surface Detection)
- Electronics: DAE4 Sn755; Calibrated: 2023/03/23
- Phantom: SAM Right ; Type: QD000P40CD; Serial: TP:1502
- Measurement SW: DASY52, Version 52.8 (8); SEMCAD X Version 14.6.14 (7483)

Pin=250mW/Area Scan (51x81x1): Interpolated grid: dx=1.000 mm, dy=1.000 mm

Maximum value of SAR (interpolated) = 15.8 W/kg

Pin=250mW/Zoom Scan (7x7x6)/Cube 0: Measurement grid: dx=4mm, dy=4mm, dz=2mm

Reference Value = 54.51 V/m; Power Drift = -0.01 dB

Peak SAR (extrapolated) = 27.7 W/kg

SAR(1 g) = 7.43 W/kg; SAR(10 g) = 2.14 W/kg

Smallest distance from peaks to all points 3 dB below = 7.2 mm

Ratio of SAR at M2 to SAR at M1 = 54.9%

Maximum value of SAR (measured) = 14.7 W/kg

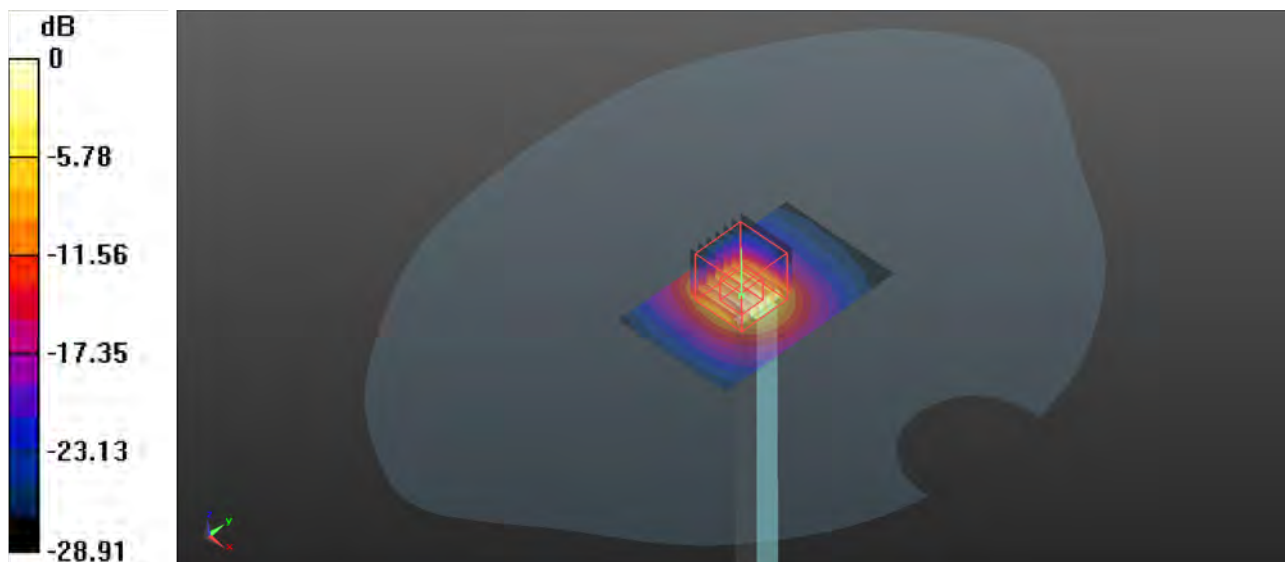

0 dB = 14.7 W/kg

System Check_HSL5600_240126

DUT: Dipole 5GHz; Type: D5GHzV2

Communication System: CW; Frequency: 5600 MHz; Duty Cycle: 1:1

Medium: HSL5G_0126 Medium parameters used: $f = 5600$ MHz; $\sigma = 5.016$ S/m; $\epsilon_r = 35.683$; $\rho = 1000$ kg/m³

Ambient Temperature : 23.3°C; Liquid Temperature : 22.5°C

DASY5 Configuration:

- Probe: EX3DV4 - SN3985; ConvF(5.08, 5.08, 5.08) @ 5600 MHz; Calibrated: 2023/07/10
- Sensor-Surface: 2mm (Mechanical Surface Detection)
- Electronics: DAE4 Sn755; Calibrated: 2023/03/23
- Phantom: SAM Right ; Type: QD000P40CD; Serial: TP:1502
- Measurement SW: DASY52, Version 52.8 (8); SEMCAD X Version 14.6.14 (7483)

Pin=250mW/Area Scan (51x81x1): Interpolated grid: dx=1.000 mm, dy=1.000 mm

Maximum value of SAR (interpolated) = 18.0 W/kg

Pin=250mW/Zoom Scan (7x7x6)/Cube 0: Measurement grid: dx=4mm, dy=4mm, dz=2mm

Reference Value = 59.41 V/m; Power Drift = 0.04 dB

Peak SAR (extrapolated) = 33.1 W/kg

SAR(1 g) = 8.15 W/kg; SAR(10 g) = 2.42 W/kg

Smallest distance from peaks to all points 3 dB below = 7.9 mm

Ratio of SAR at M2 to SAR at M1 = 53%

Maximum value of SAR (measured) = 17.0 W/kg

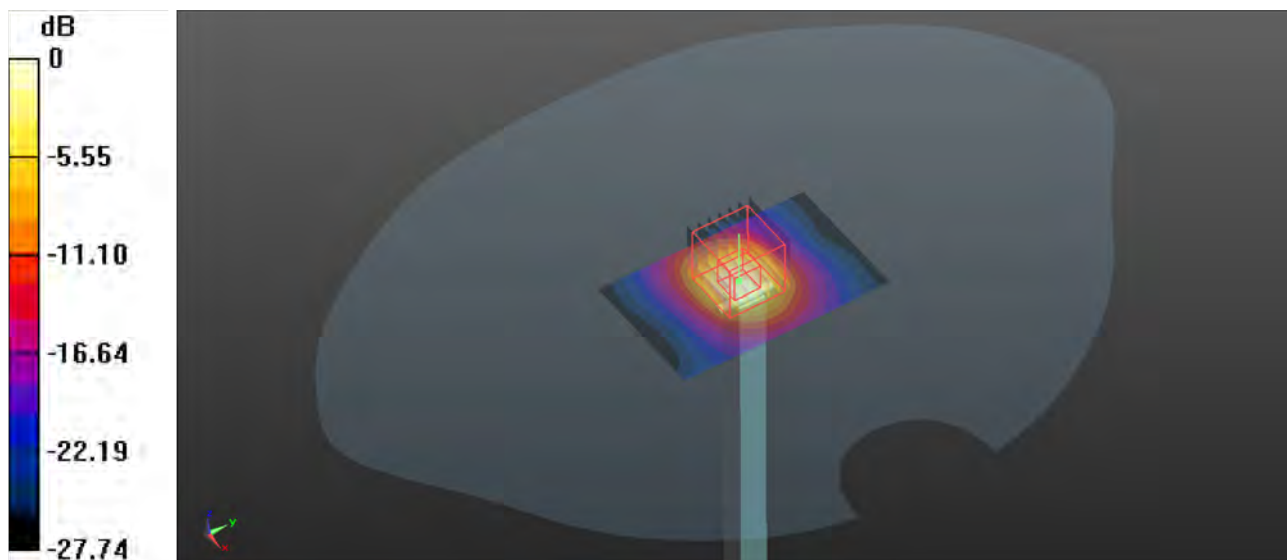

0 dB = 17.0 W/kg

System Check_HSL5750_240126

DUT: Dipole 5GHz; Type: D5GHzV2

Communication System: CW; Frequency: 5750 MHz; Duty Cycle: 1:1

Medium: HSL5G_0126 Medium parameters used: $f = 5750$ MHz; $\sigma = 5.124$ S/m; $\epsilon_r = 35.379$; $\rho = 1000$ kg/m³

Ambient Temperature : 23.3°C; Liquid Temperature : 22.5°C

DASY5 Configuration:

- Probe: EX3DV4 - SN3985; ConvF(5.16, 5.16, 5.16) @ 5750 MHz; Calibrated: 2023/07/10
- Sensor-Surface: 2mm (Mechanical Surface Detection)
- Electronics: DAE4 Sn755; Calibrated: 2023/03/23
- Phantom: SAM Right ; Type: QD000P40CD; Serial: TP:1502
- Measurement SW: DASY52, Version 52.8 (8); SEMCAD X Version 14.6.14 (7483)

Pin=250mW/Area Scan (51x81x1): Interpolated grid: dx=1.000 mm, dy=1.000 mm

Maximum value of SAR (interpolated) = 18.3 W/kg

Pin=250mW/Zoom Scan (7x7x12)/Cube 0: Measurement grid: dx=4mm, dy=4mm, dz=2mm

Reference Value = 35.78 V/m; Power Drift = 0.05 dB

Peak SAR (extrapolated) = 29.3 W/kg

SAR(1 g) = 7.82 W/kg; SAR(10 g) = 2.22 W/kg

Smallest distance from peaks to all points 3 dB below = 7.2 mm

Ratio of SAR at M2 to SAR at M1 = 51.9%

Maximum value of SAR (measured) = 18.1 W/kg

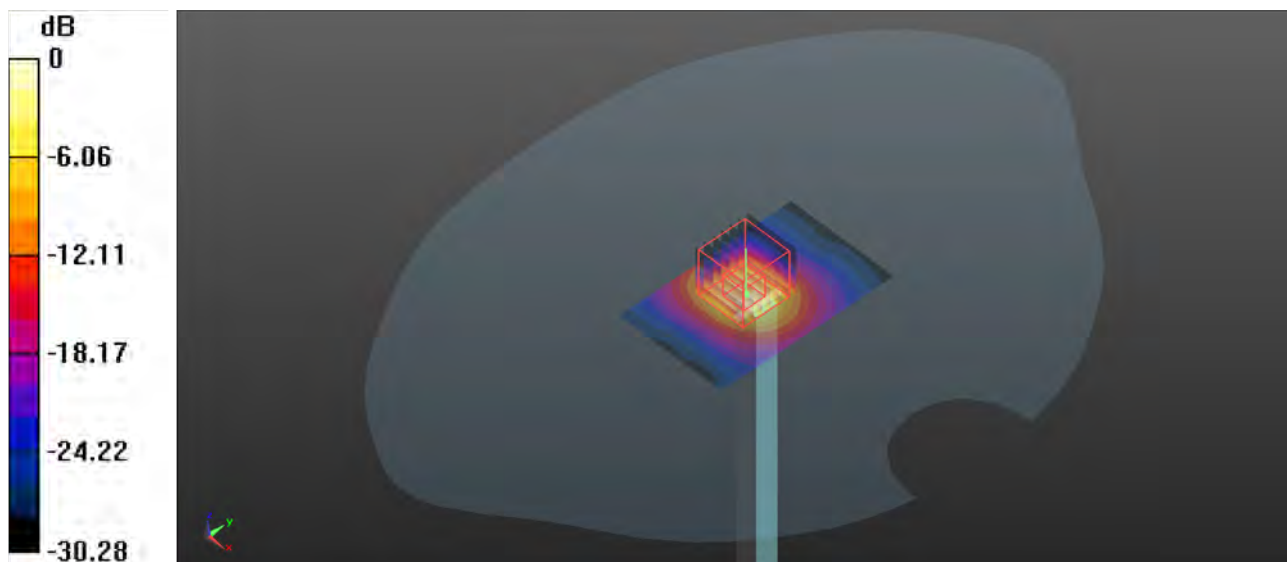

0 dB = 18.1 W/kg

Appendix B. SAR Plots of SAR Measurement

The SAR plots for highest measured SAR in each exposure configuration, wireless mode and frequency band combination, and measured SAR > 1.5 W/kg are shown as follows.

P01 GSM850_GPRS 4Tx Slot_Left Cheek_Ch251

Communication System: GPRS 4Tx Slot; Frequency: 848.8 MHz; Duty Cycle: 1:2.08
Medium: HSL835_0111 Medium parameters used: $f = 849$ MHz; $\sigma = 0.95$ S/m; $\epsilon_r = 42.941$; $\rho = 1000$ kg/m³

Ambient Temperature : 23.3°C; Liquid Temperature : 22.6°C

DASY5 Configuration:

- Probe: EX3DV4 - SN3985; ConvF(9.9, 9.9, 9.9) @ 848.8 MHz; Calibrated: 2023/07/10
- Sensor-Surface: 2mm (Mechanical Surface Detection)
- Electronics: DAE4 Sn755; Calibrated: 2023/03/23
- Phantom: SAM Right ; Type: QD000P40CD; Serial: TP:1502
- Measurement SW: DASY52, Version 52.8 (8); SEMCAD X Version 14.6.14 (7483)

-Area Scan (71x131x1): Interpolated grid: dx=1.500 mm, dy=1.500 mm
Maximum value of SAR (interpolated) = 0.135 W/kg

-Zoom Scan (5x5x7)/Cube 0: Measurement grid: dx=8mm, dy=8mm, dz=5mm
Reference Value = 4.016 V/m; Power Drift = -0.02 dB
Peak SAR (extrapolated) = 0.268 W/kg
SAR(1 g) = 0.157 W/kg; SAR(10 g) = 0.089 W/kg
Smallest distance from peaks to all points 3 dB below = 4.5 mm
Ratio of SAR at M2 to SAR at M1 = 77.3%
Maximum value of SAR (measured) = 0.140 W/kg

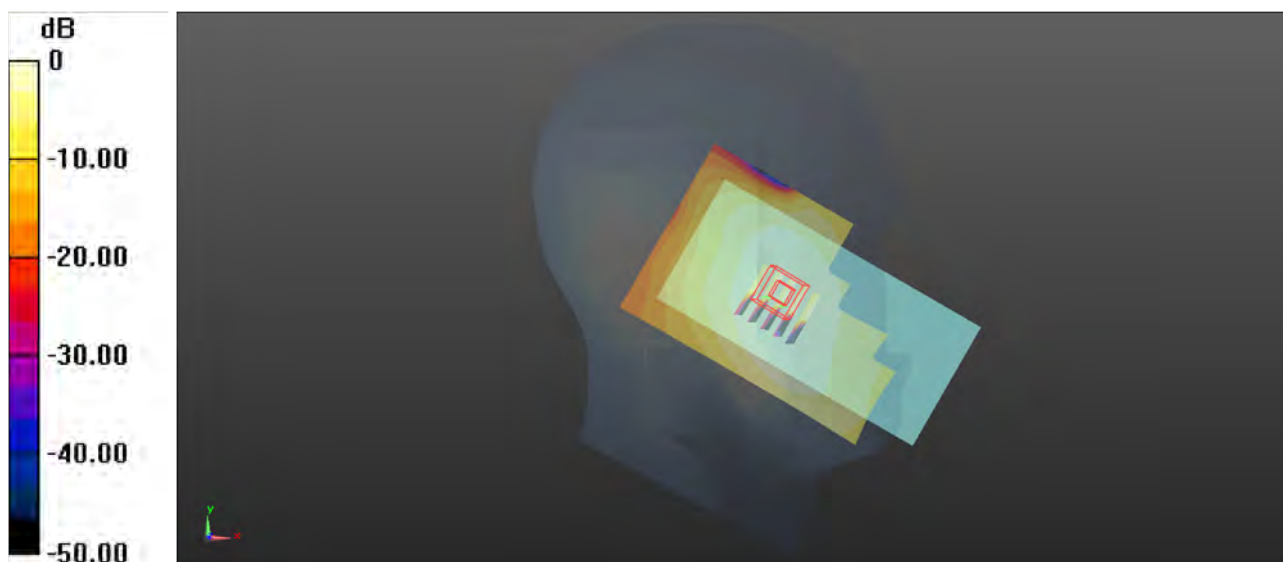

0 dB = 0.140 W/kg

P02 GSM1900_GPRS 4Tx Slot_Right Tilted_Ch810

Communication System: GPRS 4Tx Slot; Frequency: 1909.8 MHz; Duty Cycle: 1:2.08
Medium: HSL1950_0122 Medium parameters used: $f = 1910$ MHz; $\sigma = 1.45$ S/m; $\epsilon_r = 39.477$; $\rho = 1000$ kg/m³
Ambient Temperature : 23.5°C; Liquid Temperature : 22.6°C

DASY5 Configuration:

- Probe: EX3DV4 - SN3985; ConvF(8.26, 8.26, 8.26) @ 1909.8 MHz; Calibrated: 2023/07/10
- Sensor-Surface: 2mm (Mechanical Surface Detection)
- Electronics: DAE4 Sn755; Calibrated: 2023/03/23
- Phantom: SAM Right ; Type: QD000P40CD; Serial: TP:1502
- Measurement SW: DASY52, Version 52.8 (8); SEMCAD X Version 14.6.14 (7483)

-Area Scan (71x71x1): Interpolated grid: dx=1.500 mm, dy=1.500 mm
Maximum value of SAR (interpolated) = 0.622 W/kg

-Zoom Scan (5x5x7)/Cube 0: Measurement grid: dx=8mm, dy=8mm, dz=5mm
Reference Value = 15.45 V/m; Power Drift = 0.05 dB
Peak SAR (extrapolated) = 1.13 W/kg
SAR(1 g) = 0.594 W/kg; SAR(10 g) = 0.284 W/kg
Smallest distance from peaks to all points 3 dB below = 8 mm
Ratio of SAR at M2 to SAR at M1 = 53%
Maximum value of SAR (measured) = 0.829 W/kg

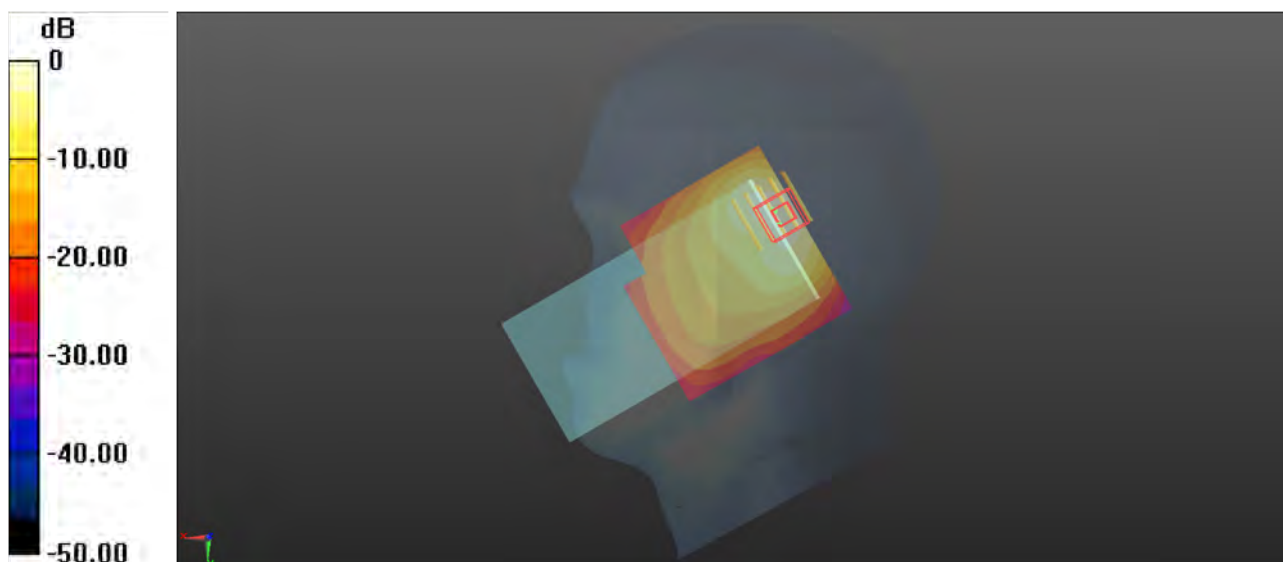

0 dB = 0.829 W/kg

P03 WCDMA II_RMC12.2K_Right Tilted_Ch9400

Communication System: WCDMA; Frequency: 1880 MHz; Duty Cycle: 1:1
Medium: HSL1950_0122 Medium parameters used: $f = 1880$ MHz; $\sigma = 1.43$ S/m; $\epsilon_r = 39.497$; $\rho = 1000$ kg/m³
Ambient Temperature : 23.5°C; Liquid Temperature : 22.6°C

DASY5 Configuration:

- Probe: EX3DV4 - SN3985; ConvF(8.26, 8.26, 8.26) @ 1880 MHz; Calibrated: 2023/07/10
- Sensor-Surface: 2mm (Mechanical Surface Detection)
- Electronics: DAE4 Sn755; Calibrated: 2023/03/23
- Phantom: SAM Right ; Type: QD000P40CD; Serial: TP:1502
- Measurement SW: DASY52, Version 52.8 (8); SEMCAD X Version 14.6.14 (7483)

-Area Scan (71x71x1): Interpolated grid: dx=1.500 mm, dy=1.500 mm
Maximum value of SAR (interpolated) = 1.07 W/kg

-Zoom Scan (5x5x7)/Cube 0: Measurement grid: dx=8mm, dy=8mm, dz=5mm
Reference Value = 21.09 V/m; Power Drift = 0.11 dB
Peak SAR (extrapolated) = 1.82 W/kg
SAR(1 g) = 0.965 W/kg; SAR(10 g) = 0.467 W/kg
Smallest distance from peaks to all points 3 dB below = 8 mm
Ratio of SAR at M2 to SAR at M1 = 54.2%
Maximum value of SAR (measured) = 1.26 W/kg

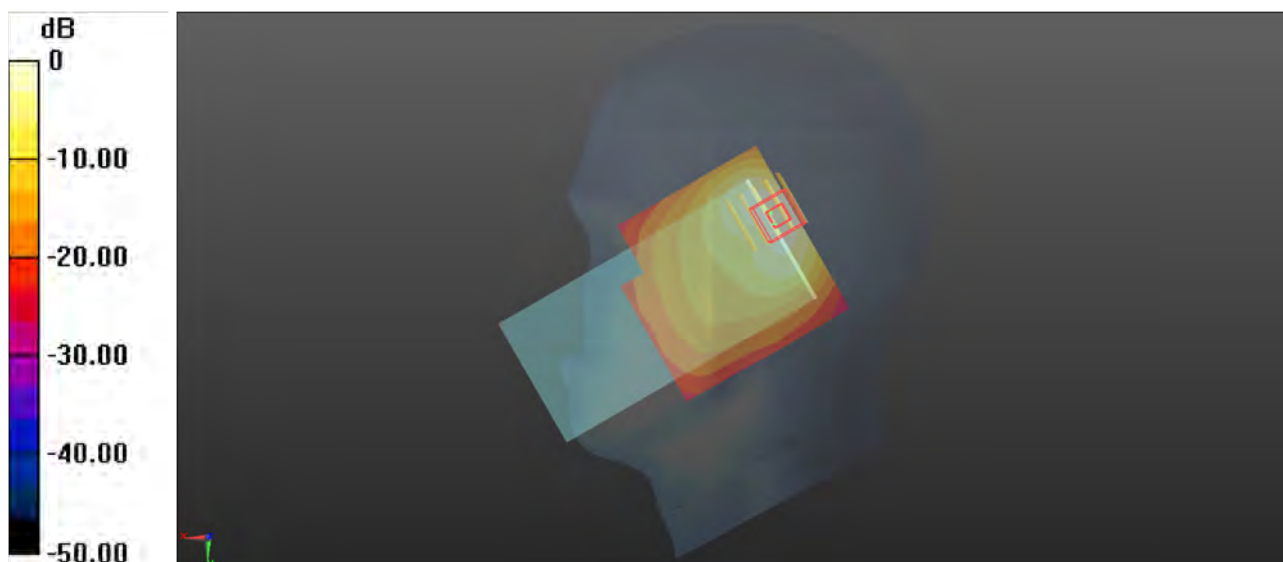

0 dB = 1.26 W/kg

P04 WCDMA V_RMC12.2K_Left Cheek_Ch4182

Communication System: WCDMA; Frequency: 836.4 MHz; Duty Cycle: 1:1

Medium: HSL835_0111 Medium parameters used: $f = 836.4$ MHz; $\sigma = 0.945$ S/m; $\epsilon_r = 42.979$; $\rho = 1000$ kg/m³

Ambient Temperature : 23.3°C; Liquid Temperature : 22.6°C

DASY5 Configuration:

- Probe: EX3DV4 - SN3985; ConvF(9.9, 9.9, 9.9) @ 836.4 MHz; Calibrated: 2023/07/10
- Sensor-Surface: 2mm (Mechanical Surface Detection)
- Electronics: DAE4 Sn755; Calibrated: 2023/03/23
- Phantom: SAM Right ; Type: QD000P40CD; Serial: TP:1502
- Measurement SW: DASY52, Version 52.8 (8); SEMCAD X Version 14.6.14 (7483)

-Area Scan (71x131x1): Interpolated grid: dx=1.500 mm, dy=1.500 mm

Maximum value of SAR (interpolated) = 0.200 W/kg

-Zoom Scan (5x5x7)/Cube 0: Measurement grid: dx=8mm, dy=8mm, dz=5mm

Reference Value = 3.875 V/m; Power Drift = -0.02 dB

Peak SAR (extrapolated) = 0.223 W/kg

SAR(1 g) = 0.178 W/kg; SAR(10 g) = 0.138 W/kg

Smallest distance from peaks to all points 3 dB below: Larger than measurement grid

Ratio of SAR at M2 to SAR at M1 = 80.2%

Maximum value of SAR (measured) = 0.203 W/kg

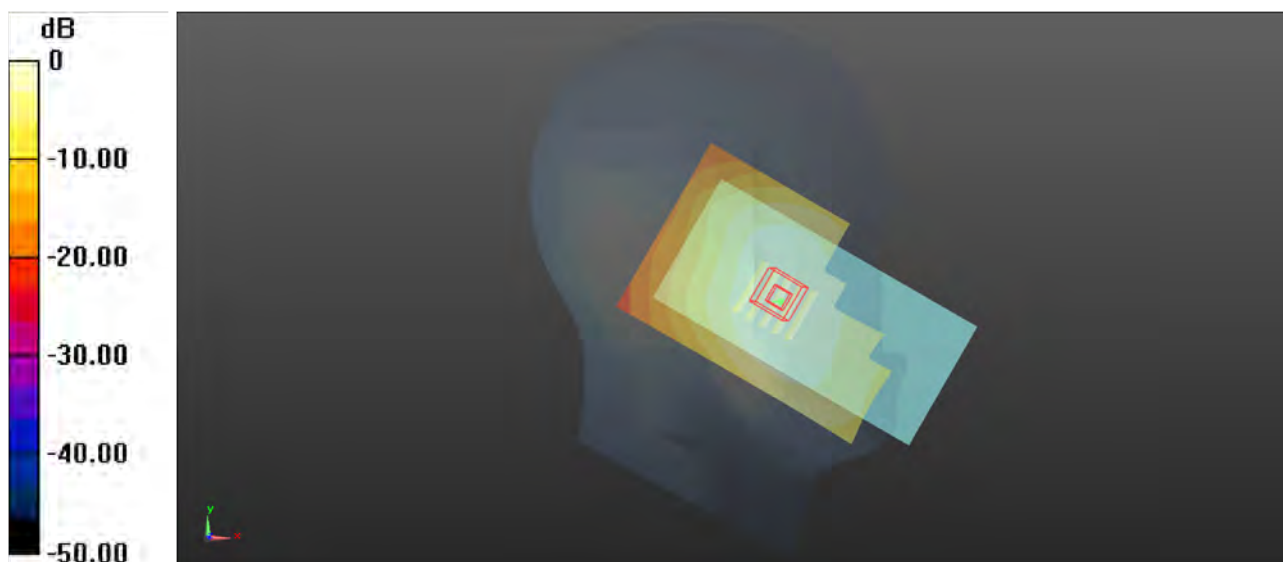

0 dB = 0.203 W/kg

P05 LTE 2_QPSK20M_Right Tilted_Ch18900_50RB_OS25

Communication System: LTE_FDD; Frequency: 1880 MHz; Duty Cycle: 1:1
Medium: HSL1950_0123 Medium parameters used: $f = 1880$ MHz; $\sigma = 1.424$ S/m; $\epsilon_r = 39.46$; $\rho = 1000$ kg/m³
Ambient Temperature : 23.1°C; Liquid Temperature : 22.3°C

DASY5 Configuration:

- Probe: EX3DV4 - SN3985; ConvF(8.26, 8.26, 8.26) @ 1880 MHz; Calibrated: 2023/07/10
- Sensor-Surface: 2mm (Mechanical Surface Detection)
- Electronics: DAE4 Sn755; Calibrated: 2023/03/23
- Phantom: SAM Right ; Type: QD000P40CD; Serial: TP:1502
- Measurement SW: DASY52, Version 52.8 (8); SEMCAD X Version 14.6.14 (7483)

-Area Scan (71x71x1): Interpolated grid: dx=1.500 mm, dy=1.500 mm
Maximum value of SAR (interpolated) = 1.19 W/kg

-Zoom Scan (5x5x7)/Cube 0: Measurement grid: dx=8mm, dy=8mm, dz=5mm
Reference Value = 21.53 V/m; Power Drift = 0.06 dB
Peak SAR (extrapolated) = 2.01 W/kg
SAR(1 g) = 1.04 W/kg; SAR(10 g) = 0.501 W/kg
Smallest distance from peaks to all points 3 dB below = 8 mm
Ratio of SAR at M2 to SAR at M1 = 51.1%
Maximum value of SAR (measured) = 1.44 W/kg

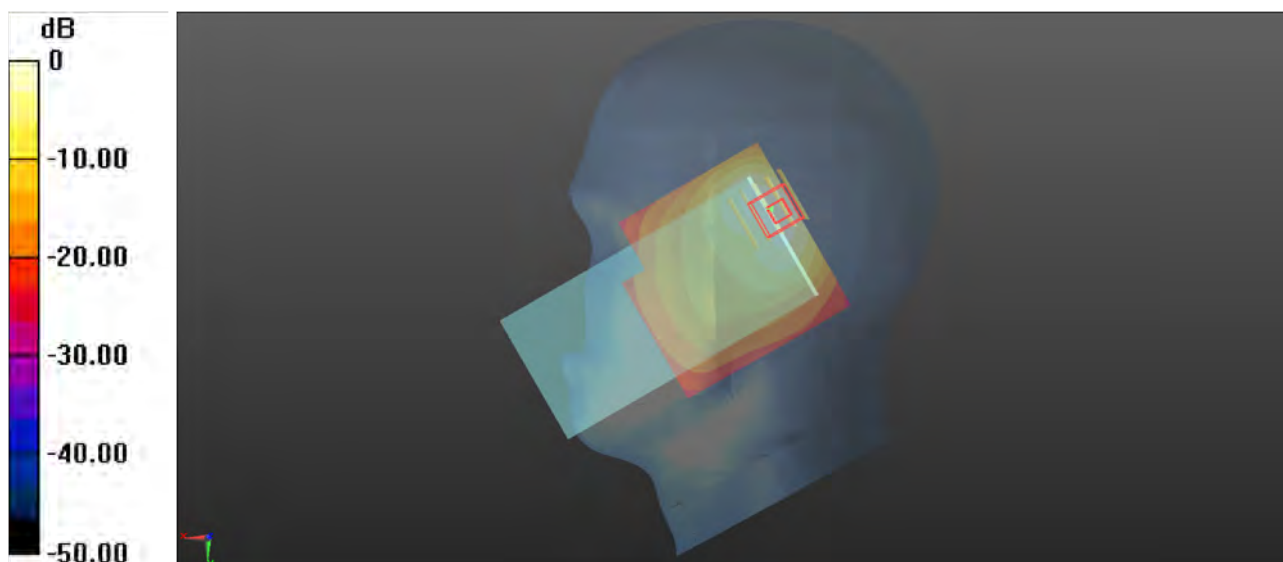

0 dB = 1.44 W/kg

P06 LTE 5_QPSK10M_Left Cheek_Ch20450_1RB_OS49

Communication System: LTE_FDD; Frequency: 829 MHz; Duty Cycle: 1:1
Medium: HSL835_0111 Medium parameters used: $f = 829$ MHz; $\sigma = 0.942$ S/m; $\epsilon_r = 43.004$; $\rho = 1000$ kg/m³
Ambient Temperature : 23.3°C; Liquid Temperature : 22.6°C

DASY5 Configuration:

- Probe: EX3DV4 - SN3985; ConvF(9.9, 9.9, 9.9) @ 829 MHz; Calibrated: 2023/07/10
- Sensor-Surface: 2mm (Mechanical Surface Detection)
- Electronics: DAE4 Sn755; Calibrated: 2023/03/23
- Phantom: SAM Right ; Type: QD000P40CD; Serial: TP:1502
- Measurement SW: DASY52, Version 52.8 (8); SEMCAD X Version 14.6.14 (7483)

-Area Scan (71x131x1): Interpolated grid: dx=1.500 mm, dy=1.500 mm
Maximum value of SAR (interpolated) = 0.176 W/kg

-Zoom Scan (5x5x7)/Cube 0: Measurement grid: dx=8mm, dy=8mm, dz=5mm
Reference Value = 3.737 V/m; Power Drift = 0.02 dB
Peak SAR (extrapolated) = 0.196 W/kg
SAR(1 g) = 0.158 W/kg; SAR(10 g) = 0.123 W/kg
Smallest distance from peaks to all points 3 dB below: Larger than measurement grid
Ratio of SAR at M2 to SAR at M1 = 81.3%
Maximum value of SAR (measured) = 0.179 W/kg

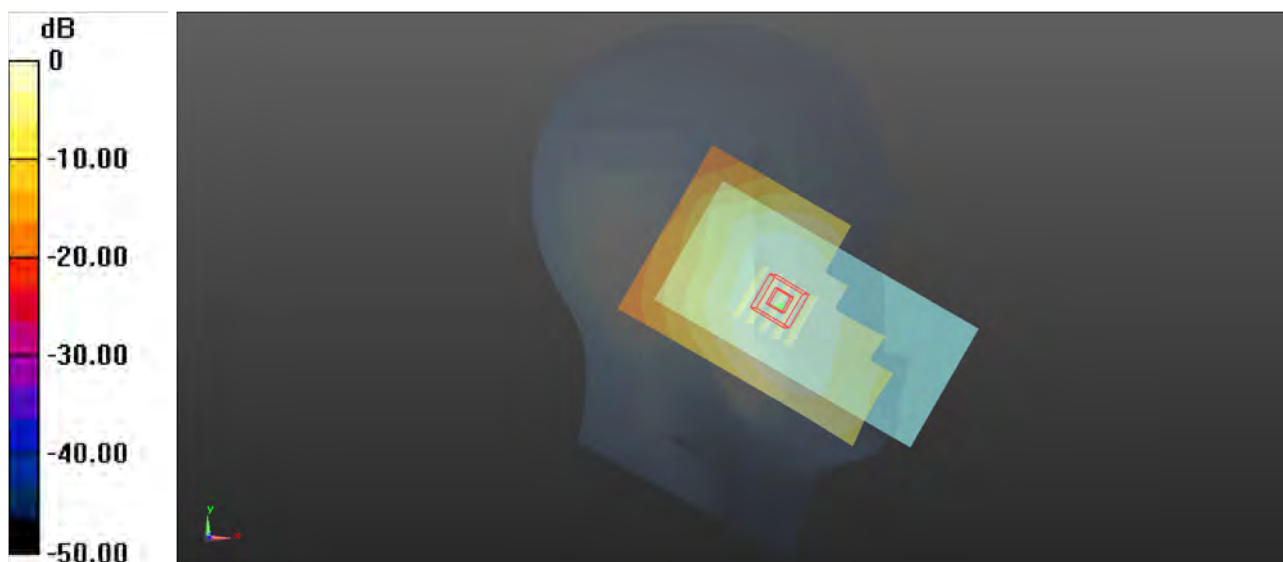

0 dB = 0.179 W/kg

P07 LTE 12_QPSK10M_Left Cheek_Ch23130_1RB_OS0

Communication System: LTE_FDD; Frequency: 711 MHz; Duty Cycle: 1:1
Medium: HSL750_0112 Medium parameters used: $f = 711$ MHz; $\sigma = 0.896$ S/m; $\epsilon_r = 42.995$; $\rho = 1000$ kg/m³
Ambient Temperature : 23.4°C; Liquid Temperature : 22.5°C

DASY5 Configuration:

- Probe: EX3DV4 - SN3985; ConvF(10.3, 10.3, 10.3) @ 711 MHz; Calibrated: 2023/07/10
- Sensor-Surface: 2mm (Mechanical Surface Detection)
- Electronics: DAE4 Sn755; Calibrated: 2023/03/23
- Phantom: SAM Right ; Type: QD000P40CD; Serial: TP:1502
- Measurement SW: DASY52, Version 52.8 (8); SEMCAD X Version 14.6.14 (7483)

-Area Scan (71x131x1): Interpolated grid: dx=1.500 mm, dy=1.500 mm
Maximum value of SAR (interpolated) = 0.108 W/kg

-Zoom Scan (5x5x7)/Cube 0: Measurement grid: dx=8mm, dy=8mm, dz=5mm
Reference Value = 2.769 V/m; Power Drift = 0.04 dB
Peak SAR (extrapolated) = 0.119 W/kg
SAR(1 g) = 0.097 W/kg; SAR(10 g) = 0.077 W/kg
Smallest distance from peaks to all points 3 dB below: Larger than measurement grid
Ratio of SAR at M2 to SAR at M1 = 82%
Maximum value of SAR (measured) = 0.109 W/kg

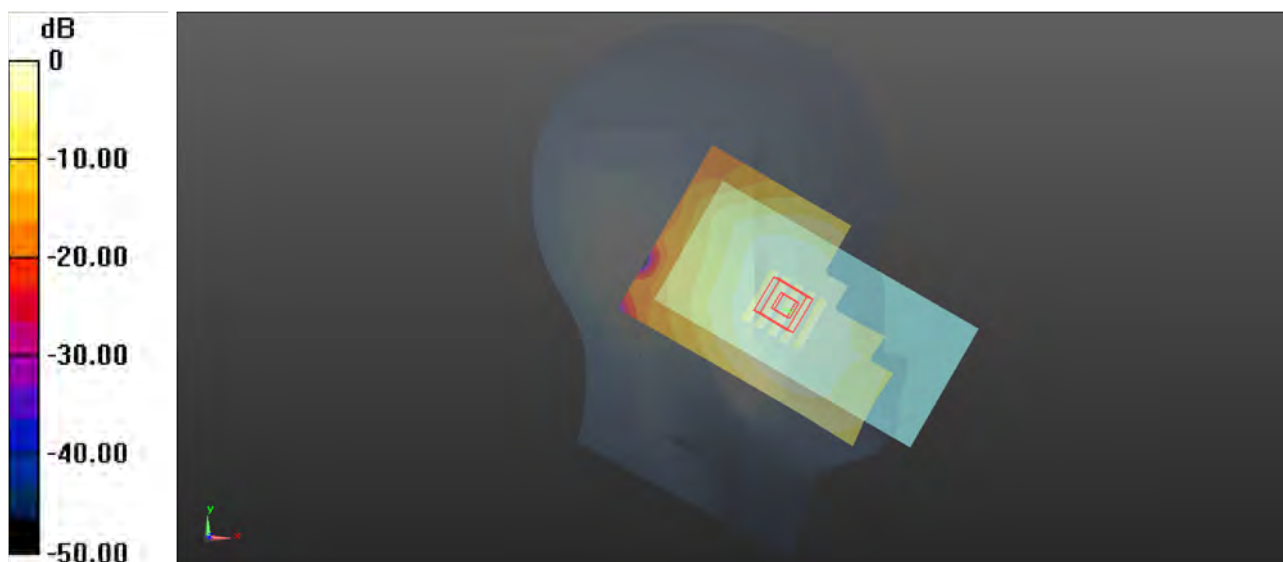

0 dB = 0.109 W/kg

P08 LTE 13_QPSK10M_Right Cheek_Ch23230_1RB_OS49

Communication System: LTE_FDD; Frequency: 782 MHz; Duty Cycle: 1:1
Medium: HSL750_0112 Medium parameters used: $f = 782$ MHz; $\sigma = 0.918$ S/m; $\epsilon_r = 42.794$; $\rho = 1000$ kg/m³
Ambient Temperature : 23.4°C; Liquid Temperature : 22.5°C

DASY5 Configuration:

- Probe: EX3DV4 - SN3985; ConvF(10.3, 10.3, 10.3) @ 782 MHz; Calibrated: 2023/07/10
- Sensor-Surface: 2mm (Mechanical Surface Detection)
- Electronics: DAE4 Sn755; Calibrated: 2023/03/23
- Phantom: SAM Right ; Type: QD000P40CD; Serial: TP:1502
- Measurement SW: DASY52, Version 52.8 (8); SEMCAD X Version 14.6.14 (7483)

-Area Scan (71x131x1): Interpolated grid: dx=1.500 mm, dy=1.500 mm
Maximum value of SAR (interpolated) = 0.110 W/kg

-Zoom Scan (5x5x7)/Cube 0: Measurement grid: dx=8mm, dy=8mm, dz=5mm
Reference Value = 2.799 V/m; Power Drift = -0.14 dB
Peak SAR (extrapolated) = 0.119 W/kg
SAR(1 g) = 0.095 W/kg; SAR(10 g) = 0.073 W/kg
Smallest distance from peaks to all points 3 dB below: Larger than measurement grid
Ratio of SAR at M2 to SAR at M1 = 79.6%
Maximum value of SAR (measured) = 0.108 W/kg

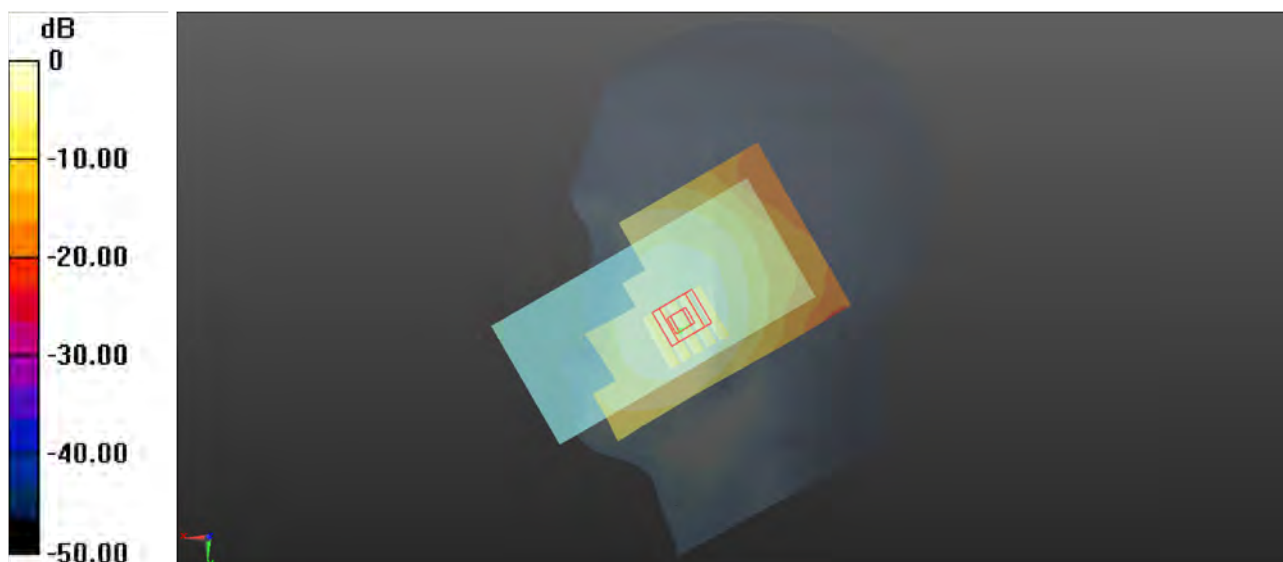

0 dB = 0.108 W/kg

P09 LTE 66_QPSK20M_Right Tilted_Ch132572_50RB_OS50

Communication System: LTE_FDD; Frequency: 1770 MHz; Duty Cycle: 1:1

Medium: HSL1750_0124 Medium parameters used: $f = 1770$ MHz; $\sigma = 1.379$ S/m; $\epsilon_r = 40.344$; $\rho = 1000$ kg/m³

Ambient Temperature : 23.3°C; Liquid Temperature : 22.4°C

DASY5 Configuration:

- Probe: EX3DV4 - SN3985; ConvF(8.53, 8.53, 8.53) @ 1770 MHz; Calibrated: 2023/07/10
- Sensor-Surface: 2mm (Mechanical Surface Detection)
- Electronics: DAE4 Sn755; Calibrated: 2023/03/23
- Phantom: SAM Right ; Type: QD000P40CD; Serial: TP:1502
- Measurement SW: DASY52, Version 52.8 (8); SEMCAD X Version 14.6.14 (7483)

-Area Scan (71x131x1): Interpolated grid: dx=1.500 mm, dy=1.500 mm

Maximum value of SAR (interpolated) = 1.39 W/kg

-Zoom Scan (5x5x7)/Cube 0: Measurement grid: dx=8mm, dy=8mm, dz=5mm

Reference Value = 24.50 V/m; Power Drift = 0.01 dB

Peak SAR (extrapolated) = 1.75 W/kg

SAR(1 g) = 0.949 W/kg; SAR(10 g) = 0.485 W/kg

Smallest distance from peaks to all points 3 dB below = 8 mm

Ratio of SAR at M2 to SAR at M1 = 58.1%

Maximum value of SAR (measured) = 1.32 W/kg

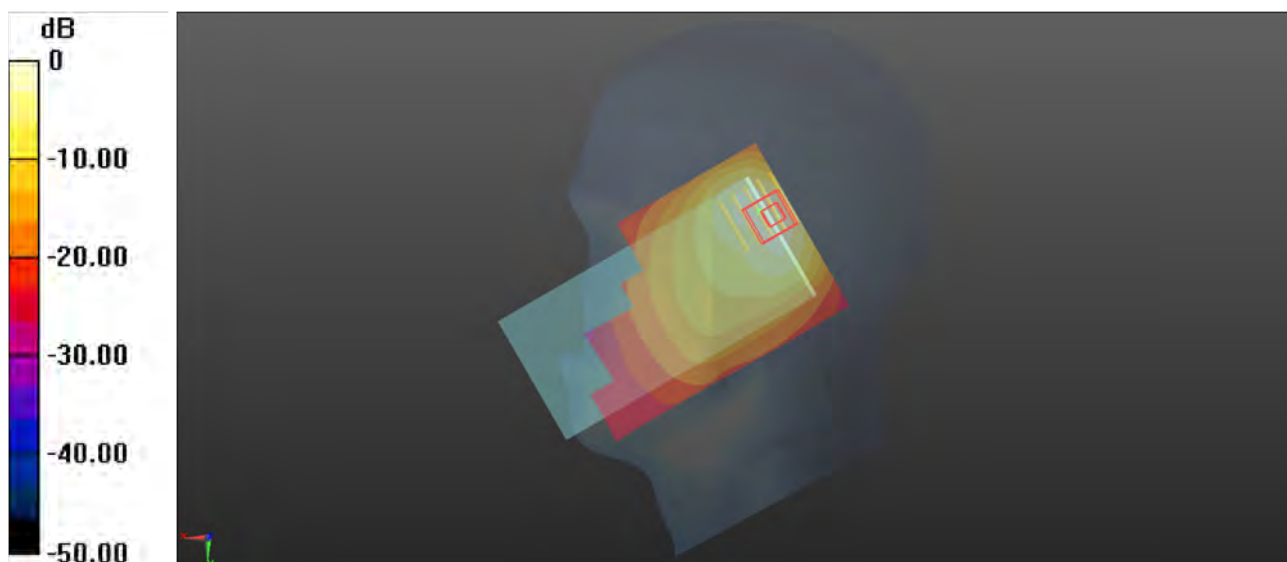

0 dB = 1.32 W/kg

P10 WLAN2.4G_802.11b_Left Cheek_Ch6

Communication System: 802.11b; Frequency: 2437 MHz; Duty Cycle: 1:1.027

Medium: HSL2450_0113 Medium parameters used: $f = 2437$ MHz; $\sigma = 1.869$ S/m; $\epsilon_r = 39.644$; $\rho = 1000$ kg/m³

Ambient Temperature : 23.2°C; Liquid Temperature : 22.7°C

DASY5 Configuration:

- Probe: EX3DV4 - SN3985; ConvF(7.8, 7.8, 7.8) @ 2437 MHz; Calibrated: 2023/07/10
- Sensor-Surface: 2mm (Mechanical Surface Detection)
- Electronics: DAE4 Sn755; Calibrated: 2023/03/23
- Phantom: SAM Right ; Type: QD000P40CD; Serial: TP:1502
- Measurement SW: DASY52, Version 52.8 (8); SEMCAD X Version 14.6.14 (7483)

-Area Scan (81x81x1): Interpolated grid: dx=1.200 mm, dy=1.200 mm

Maximum value of SAR (interpolated) = 1.49 W/kg

-Zoom Scan (7x7x7)/Cube 0: Measurement grid: dx=5mm, dy=5mm, dz=5mm

Reference Value = 14.95 V/m; Power Drift = -0.10 dB

Peak SAR (extrapolated) = 1.94 W/kg

SAR(1 g) = 0.951 W/kg; SAR(10 g) = 0.467 W/kg

Smallest distance from peaks to all points 3 dB below = 8.1 mm

Ratio of SAR at M2 to SAR at M1 = 54.5%

Maximum value of SAR (measured) = 1.36 W/kg

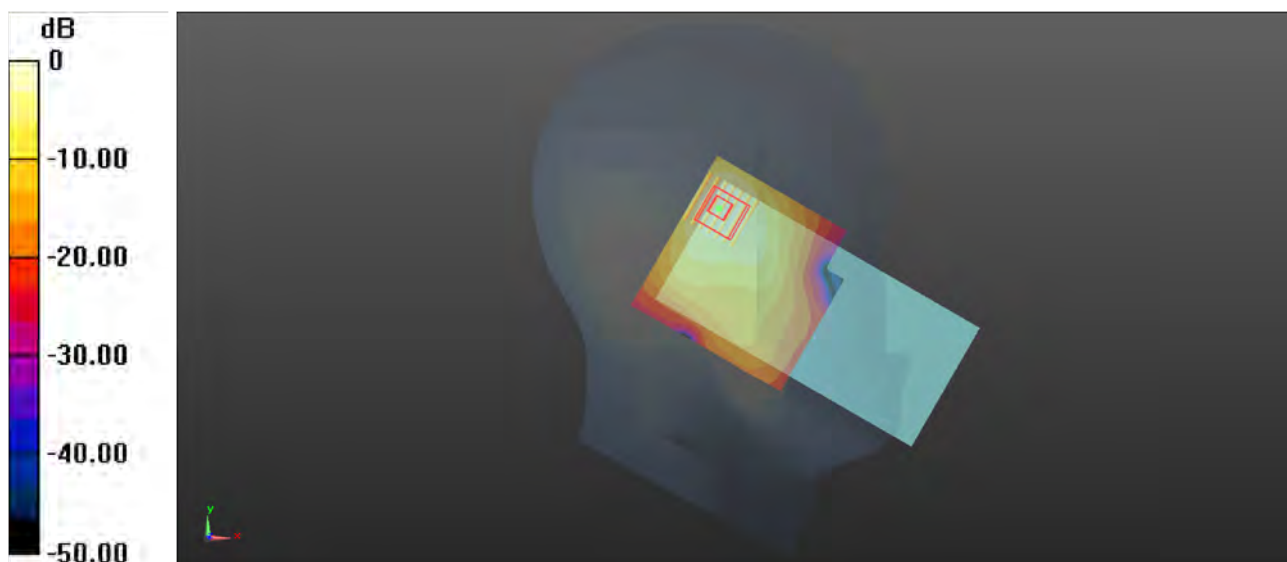

0 dB = 1.36 W/kg

P11 WLAN5G_802.11a_Left Tilted_Ch48

Communication System: 802.11a; Frequency: 5240 MHz; Duty Cycle: 1:1.018

Medium: HSL5G_0125 Medium parameters used: $f = 5240$ MHz; $\sigma = 4.541$ S/m; $\epsilon_r = 35.228$; $\rho = 1000$ kg/m³

Ambient Temperature : 23.7°C; Liquid Temperature : 22.5°C

DASY5 Configuration:

- Probe: EX3DV4 - SN3985; ConvF(5.6, 5.6, 5.6) @ 5240 MHz; Calibrated: 2023/07/10
- Sensor-Surface: 2mm (Mechanical Surface Detection)
- Electronics: DAE4 Sn755; Calibrated: 2023/03/23
- Phantom: SAM Right ; Type: QD000P40CD; Serial: TP:1502
- Measurement SW: DASY52, Version 52.8 (8); SEMCAD X Version 14.6.14 (7483)

-Area Scan (101x91x1): Interpolated grid: dx=1.000 mm, dy=1.000 mm

Maximum value of SAR (interpolated) = 2.02 W/kg

-Zoom Scan (7x7x12)/Cube 0: Measurement grid: dx=4mm, dy=4mm, dz=2mm

Reference Value = 2.049 V/m; Power Drift = 0.09 dB

Peak SAR (extrapolated) = 3.74 W/kg

SAR(1 g) = 0.899 W/kg; SAR(10 g) = 0.240 W/kg

Smallest distance from peaks to all points 3 dB below = 6.1 mm

Ratio of SAR at M2 to SAR at M1 = 55.3%

Maximum value of SAR (measured) = 1.93 W/kg

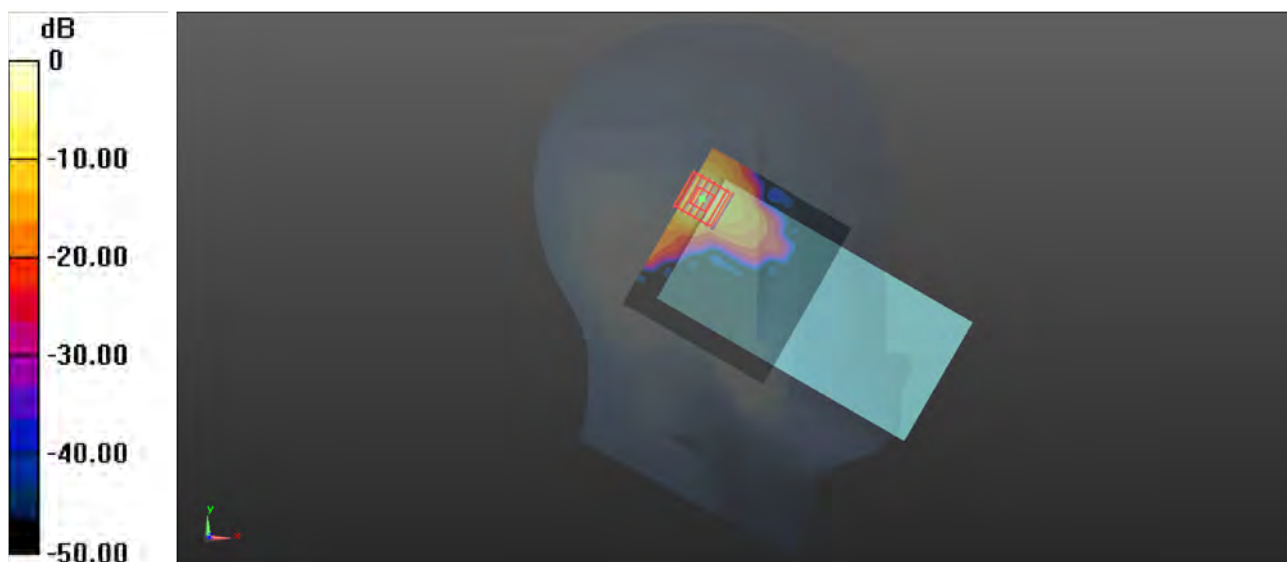

0 dB = 1.93 W/kg

P12 WLAN5G_802.11a_Left Tilted_Ch52

Communication System: 802.11a; Frequency: 5260 MHz; Duty Cycle: 1:1.018

Medium: HSL5G_0125 Medium parameters used: $f = 5260$ MHz; $\sigma = 4.584$ S/m; $\epsilon_r = 35.148$; $\rho = 1000$ kg/m³

Ambient Temperature : 23.7°C; Liquid Temperature : 22.5°C

DASY5 Configuration:

- Probe: EX3DV4 - SN3985; ConvF(5.6, 5.6, 5.6) @ 5260 MHz; Calibrated: 2023/07/10
- Sensor-Surface: 2mm (Mechanical Surface Detection)
- Electronics: DAE4 Sn755; Calibrated: 2023/03/23
- Phantom: SAM Right ; Type: QD000P40CD; Serial: TP:1502
- Measurement SW: DASY52, Version 52.8 (8); SEMCAD X Version 14.6.14 (7483)

-Area Scan (101x91x1): Interpolated grid: dx=1.000 mm, dy=1.000 mm

Maximum value of SAR (interpolated) = 2.14 W/kg

-Zoom Scan (7x7x12)/Cube 0: Measurement grid: dx=4mm, dy=4mm, dz=2mm

Reference Value = 2.379 V/m; Power Drift = -0.06 dB

Peak SAR (extrapolated) = 3.93 W/kg

SAR(1 g) = 0.946 W/kg; SAR(10 g) = 0.254 W/kg

Smallest distance from peaks to all points 3 dB below = 5.6 mm

Ratio of SAR at M2 to SAR at M1 = 55.6%

Maximum value of SAR (measured) = 2.02 W/kg

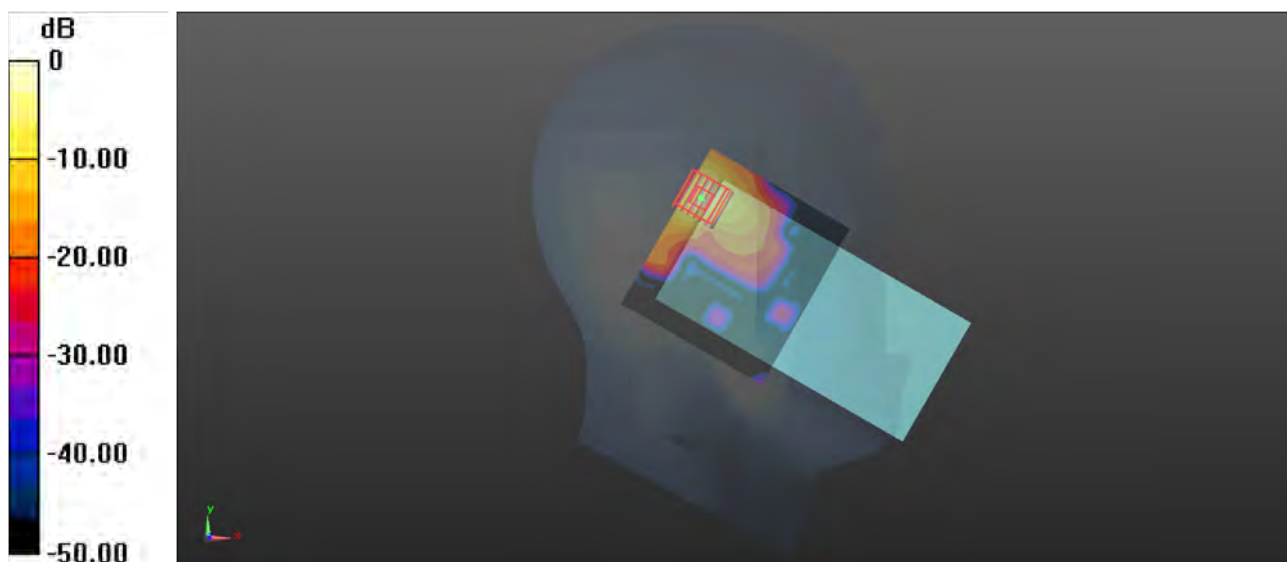

0 dB = 2.02 W/kg

P13 WLAN5G_802.11a_Left Tilted_Ch140

Communication System: 802.11a; Frequency: 5700 MHz; Duty Cycle: 1:1.018

Medium: HSL5G_0126 Medium parameters used: $f = 5700$ MHz; $\sigma = 5.096$ S/m; $\epsilon_r = 35.504$; $\rho = 1000$ kg/m³

Ambient Temperature : 23.3°C; Liquid Temperature : 22.5°C

DASY5 Configuration:

- Probe: EX3DV4 - SN3985; ConvF(5.08, 5.08, 5.08) @ 5700 MHz; Calibrated: 2023/07/10
- Sensor-Surface: 2mm (Mechanical Surface Detection)
- Electronics: DAE4 Sn755; Calibrated: 2023/03/23
- Phantom: SAM Right ; Type: QD000P40CD; Serial: TP:1502
- Measurement SW: DASY52, Version 52.8 (8); SEMCAD X Version 14.6.14 (7483)

-Area Scan (101x91x1): Interpolated grid: dx=1.000 mm, dy=1.000 mm

Maximum value of SAR (interpolated) = 1.22 W/kg

-Zoom Scan (7x7x12)/Cube 0: Measurement grid: dx=4mm, dy=4mm, dz=2mm

Reference Value = 0 V/m; Power Drift = 0.01 dB

Peak SAR (extrapolated) = 2.47 W/kg

SAR(1 g) = 0.557 W/kg; SAR(10 g) = 0.153 W/kg

Smallest distance from peaks to all points 3 dB below = 5.6 mm

Ratio of SAR at M2 to SAR at M1 = 53%

Maximum value of SAR (measured) = 1.14 W/kg

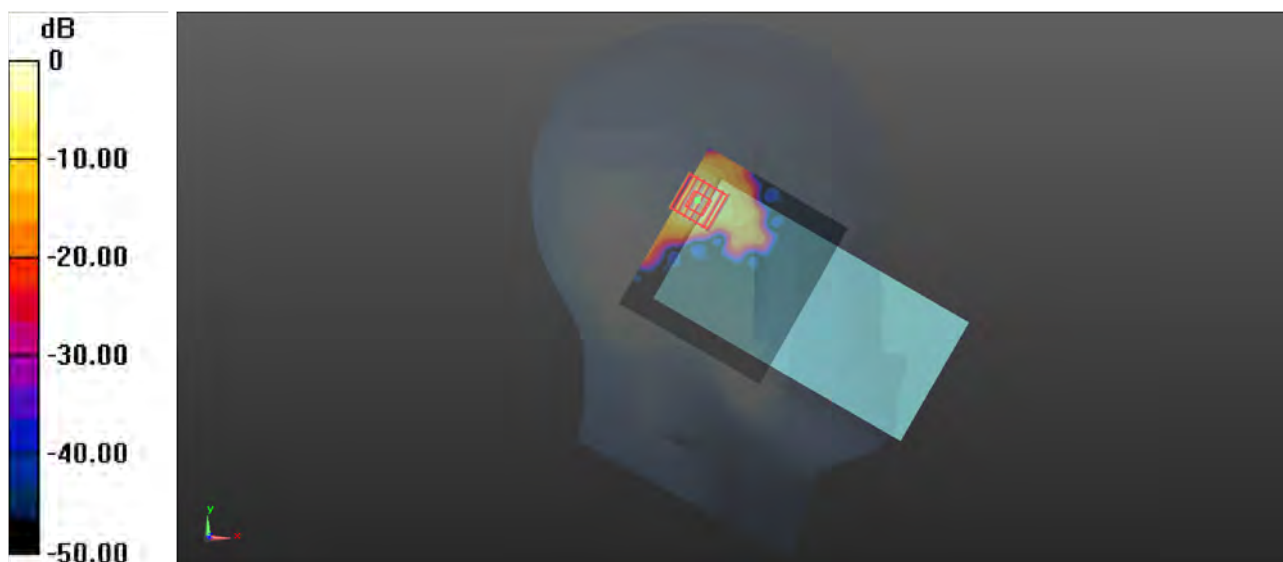

0 dB = 1.14 W/kg

P14 WLAN5G_802.11ac-VHT20_Left Tilted_Ch149

Communication System: 802.11ac_VHT20; Frequency: 5745 MHz; Duty Cycle: 1:1.038
Medium: HSL5G_0126 Medium parameters used: $f = 5745$ MHz; $\sigma = 5.155$ S/m; $\epsilon_r = 34.384$; $\rho = 1000$ kg/m³
Ambient Temperature : 23.3°C; Liquid Temperature : 22.5°C

DASY5 Configuration:

- Probe: EX3DV4 - SN3985; ConvF(5.16, 5.16, 5.16) @ 5745 MHz; Calibrated: 2023/07/10
- Sensor-Surface: 2mm (Mechanical Surface Detection)
- Electronics: DAE4 Sn755; Calibrated: 2023/03/23
- Phantom: SAM Right ; Type: QD000P40CD; Serial: TP:1502
- Measurement SW: DASY52, Version 52.8 (8); SEMCAD X Version 14.6.14 (7483)

-Area Scan (101x91x1): Interpolated grid: dx=1.000 mm, dy=1.000 mm
Maximum value of SAR (interpolated) = 1.03 W/kg

-Zoom Scan (7x7x12)/Cube 0: Measurement grid: dx=4mm, dy=4mm, dz=2mm
Reference Value = 0.7440 V/m; Power Drift = -0.09 dB
Peak SAR (extrapolated) = 2.45 W/kg
SAR(1 g) = 0.549 W/kg; SAR(10 g) = 0.156 W/kg
Smallest distance from peaks to all points 3 dB below = 6.3 mm
Ratio of SAR at M2 to SAR at M1 = 50.4%
Maximum value of SAR (measured) = 1.16 W/kg

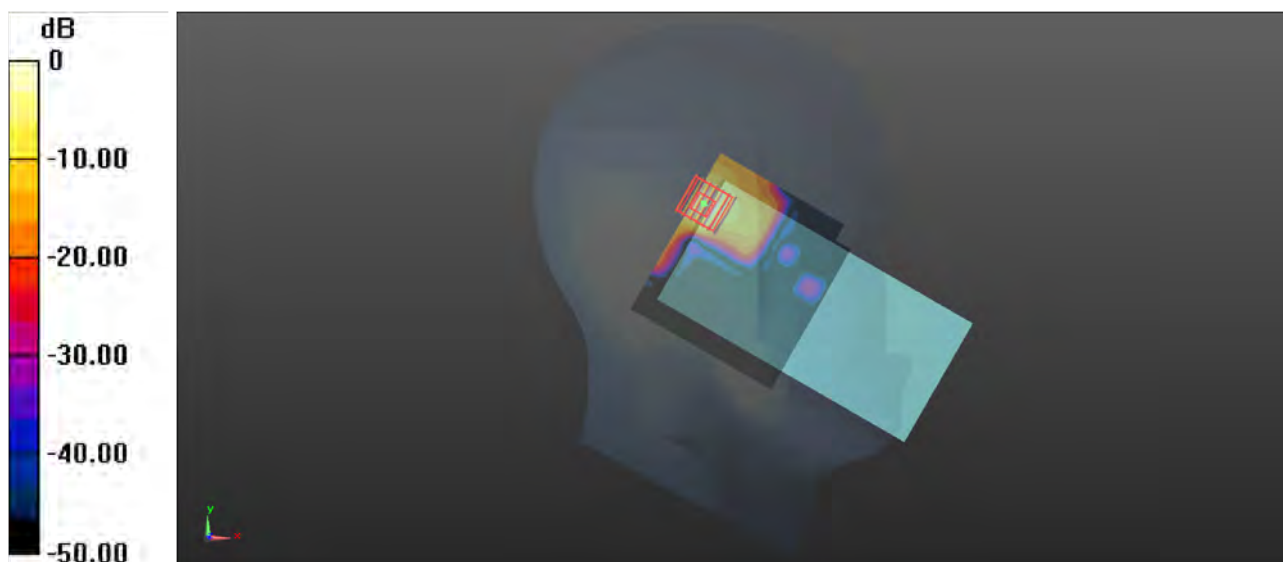

0 dB = 1.16 W/kg

P15 BT_GFSK_Left Cheek_Ch0

Communication System: BT; Frequency: 2402 MHz; Duty Cycle: 1:1.295

Medium: HSL2450_0113 Medium parameters used: $f = 2402$ MHz; $\sigma = 1.843$ S/m; $\epsilon_r = 39.707$; $\rho = 1000$ kg/m³

Ambient Temperature : 23.2°C; Liquid Temperature : 22.7°C

DASY5 Configuration:

- Probe: EX3DV4 - SN3985; ConvF(7.8, 7.8, 7.8) @ 2402 MHz; Calibrated: 2023/07/10
- Sensor-Surface: 2mm (Mechanical Surface Detection)
- Electronics: DAE4 Sn755; Calibrated: 2023/03/23
- Phantom: SAM Right ; Type: QD000P40CD; Serial: TP:1502
- Measurement SW: DASY52, Version 52.8 (8); SEMCAD X Version 14.6.14 (7483)

-Area Scan (81x81x1): Interpolated grid: dx=1.200 mm, dy=1.200 mm

Maximum value of SAR (interpolated) = 0.237 W/kg

-Zoom Scan (7x7x7)/Cube 0: Measurement grid: dx=5mm, dy=5mm, dz=5mm

Reference Value = 5.811 V/m; Power Drift = -0.04 dB

Peak SAR (extrapolated) = 0.302 W/kg

SAR(1 g) = 0.151 W/kg; SAR(10 g) = 0.075 W/kg

Smallest distance from peaks to all points 3 dB below = 10 mm

Ratio of SAR at M2 to SAR at M1 = 51%

Maximum value of SAR (measured) = 0.220 W/kg

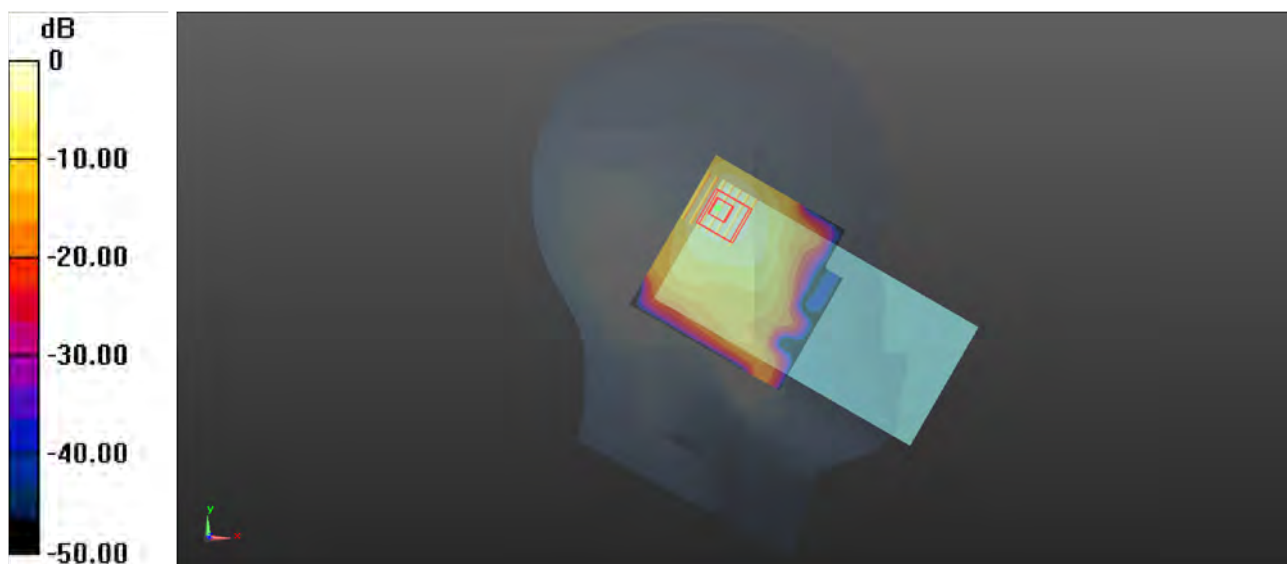

0 dB = 0.220 W/kg

P16 GSM850_GPRS 4Tx Slot_Rear Face_1cm_Ch251

Communication System: GPRS 4Tx Slot; Frequency: 848.8 MHz; Duty Cycle: 1:2.08
Medium: HSL835_0111 Medium parameters used: $f = 849$ MHz; $\sigma = 0.95$ S/m; $\epsilon_r = 42.941$; $\rho = 1000$ kg/m³
Ambient Temperature : 23.3°C; Liquid Temperature : 22.6°C

DASY5 Configuration:

- Probe: EX3DV4 - SN3985; ConvF(9.9, 9.9, 9.9) @ 848.8 MHz; Calibrated: 2023/07/10
- Sensor-Surface: 2mm (Mechanical Surface Detection)
- Electronics: DAE4 Sn755; Calibrated: 2023/03/23
- Phantom: SAM Right ; Type: QD000P40CD; Serial: TP:1502
- Measurement SW: DASY52, Version 52.8 (8); SEMCAD X Version 14.6.14 (7483)

-Area Scan (71x131x1): Interpolated grid: dx=1.500 mm, dy=1.500 mm
Maximum value of SAR (interpolated) = 0.386 W/kg

-Zoom Scan (5x5x7)/Cube 0: Measurement grid: dx=8mm, dy=8mm, dz=5mm
Reference Value = 11.96 V/m; Power Drift = -0.02 dB
Peak SAR (extrapolated) = 0.330 W/kg
SAR(1 g) = 0.203 W/kg; SAR(10 g) = 0.123 W/kg
Smallest distance from peaks to all points 3 dB below = 17.3 mm
Ratio of SAR at M2 to SAR at M1 = 61.4%
Maximum value of SAR (measured) = 0.265 W/kg

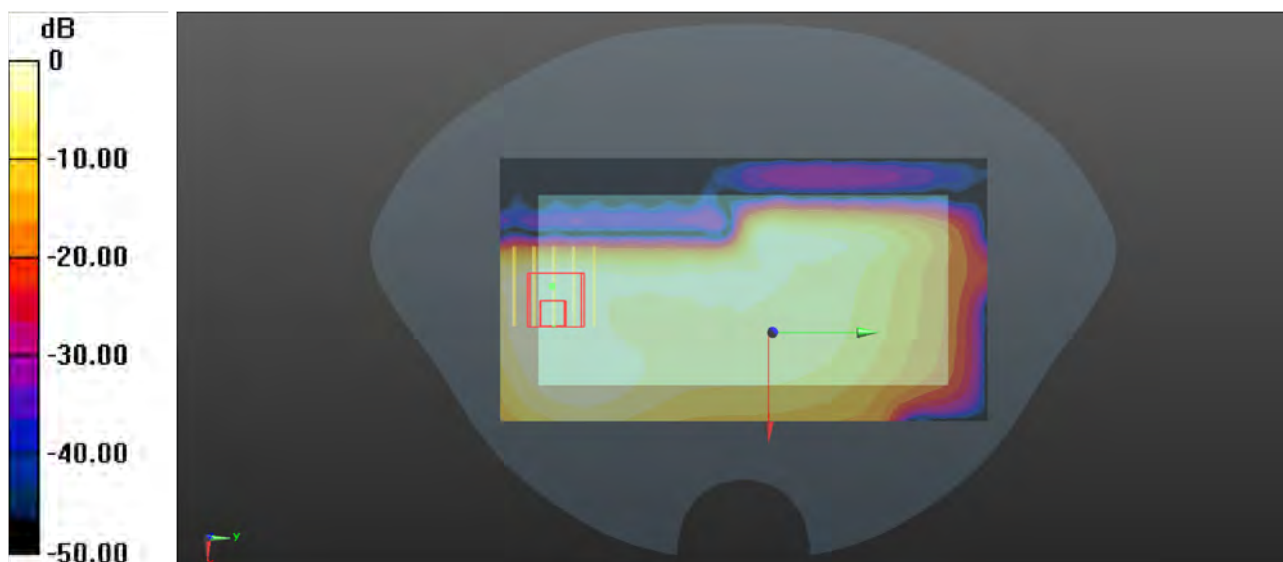

0 dB = 0.265 W/kg

P17 GSM1900_GPRS 4Tx Slot_Rear Face_1cm_Ch810

Communication System: GPRS 4Tx Slot; Frequency: 1909.8 MHz; Duty Cycle: 1:2.08
Medium: HSL1950_0122 Medium parameters used: $f = 1910$ MHz; $\sigma = 1.45$ S/m; $\epsilon_r = 39.477$; $\rho = 1000$ kg/m³
Ambient Temperature : 23.5°C; Liquid Temperature : 22.6°C

DASY5 Configuration:

- Probe: EX3DV4 - SN3985; ConvF(8.26, 8.26, 8.26) @ 1909.8 MHz; Calibrated: 2023/07/10
- Sensor-Surface: 2mm (Mechanical Surface Detection)
- Electronics: DAE4 Sn755; Calibrated: 2023/03/23
- Phantom: SAM Right ; Type: QD000P40CD; Serial: TP:1502
- Measurement SW: DASY52, Version 52.8 (8); SEMCAD X Version 14.6.14 (7483)

-Area Scan (71x71x1): Interpolated grid: dx=1.500 mm, dy=1.500 mm
Maximum value of SAR (interpolated) = 0.601 W/kg

-Zoom Scan (5x5x7)/Cube 0: Measurement grid: dx=8mm, dy=8mm, dz=5mm
Reference Value = 6.787 V/m; Power Drift = -0.09 dB
Peak SAR (extrapolated) = 0.785 W/kg
SAR(1 g) = 0.423 W/kg; SAR(10 g) = 0.223 W/kg
Smallest distance from peaks to all points 3 dB below = 10.2 mm
Ratio of SAR at M2 to SAR at M1 = 54.5%
Maximum value of SAR (measured) = 0.598 W/kg

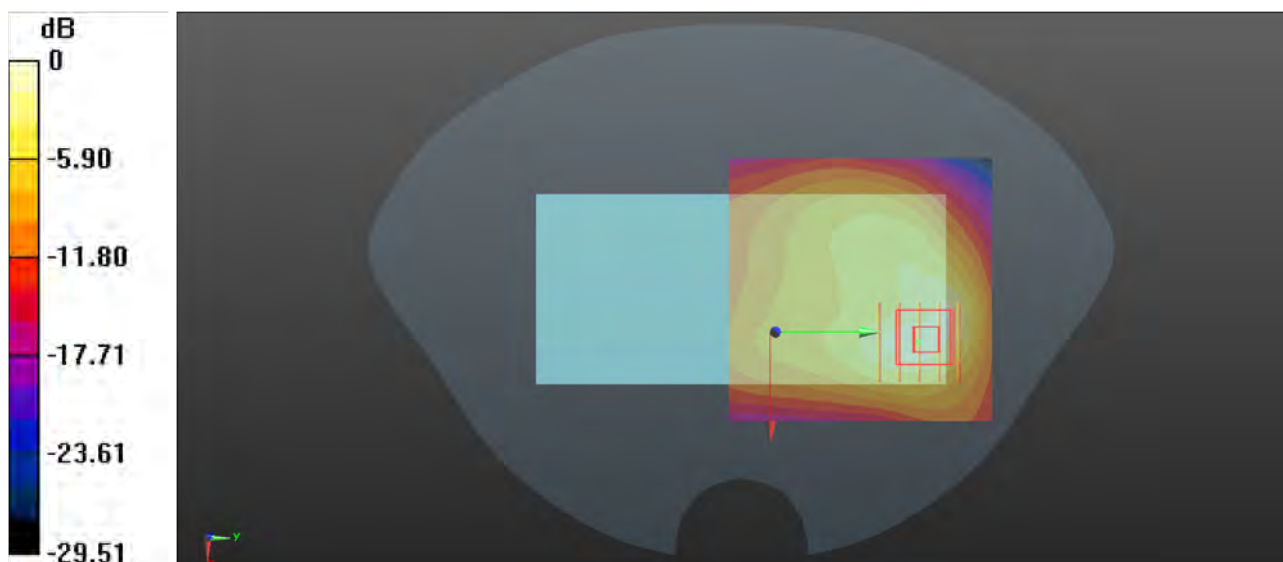

0 dB = 0.598 W/kg

P18 WCDMA II_RMC12.2K_Rear Face_1cm_Ch9538

Communication System: WCDMA; Frequency: 1907.6 MHz; Duty Cycle: 1:1
Medium: HSL1950_0122 Medium parameters used: $f = 1908$ MHz; $\sigma = 1.449$ S/m; $\epsilon_r = 39.48$; $\rho = 1000$ kg/m³
Ambient Temperature : 23.5°C; Liquid Temperature : 22.6°C

DASY5 Configuration:

- Probe: EX3DV4 - SN3985; ConvF(8.26, 8.26, 8.26) @ 1907.6 MHz; Calibrated: 2023/07/10
- Sensor-Surface: 2mm (Mechanical Surface Detection)
- Electronics: DAE4 Sn755; Calibrated: 2023/03/23
- Phantom: SAM Right ; Type: QD000P40CD; Serial: TP:1502
- Measurement SW: DASY52, Version 52.8 (8); SEMCAD X Version 14.6.14 (7483)

-Area Scan (71x71x1): Interpolated grid: dx=1.500 mm, dy=1.500 mm
Maximum value of SAR (interpolated) = 1.05 W/kg

-Zoom Scan (5x5x7)/Cube 0: Measurement grid: dx=8mm, dy=8mm, dz=5mm
Reference Value = 10.69 V/m; Power Drift = 0.13 dB
Peak SAR (extrapolated) = 1.33 W/kg
SAR(1 g) = 0.733 W/kg; SAR(10 g) = 0.392 W/kg
Smallest distance from peaks to all points 3 dB below = 10.7 mm
Ratio of SAR at M2 to SAR at M1 = 58.1%
Maximum value of SAR (measured) = 0.998 W/kg

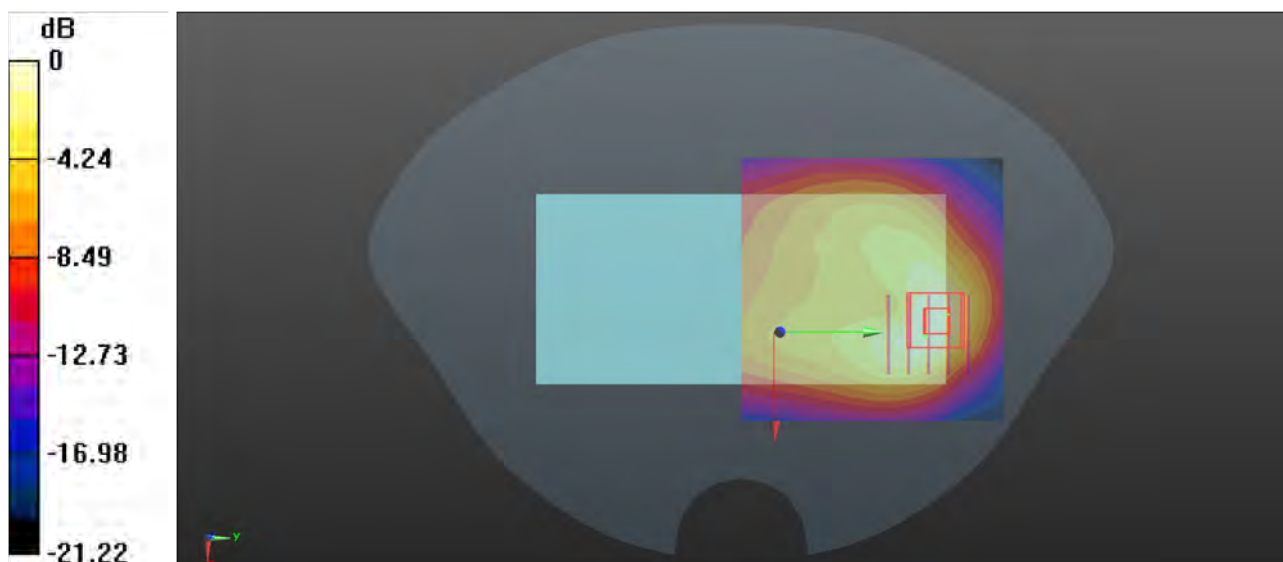

0 dB = 0.998 W/kg

P19 WCDMA V_RMC12.2K_Rear Face_1cm_Ch4182

Communication System: WCDMA; Frequency: 836.4 MHz; Duty Cycle: 1:1
Medium: HSL835_0111 Medium parameters used: $f = 836.4$ MHz; $\sigma = 0.945$ S/m; $\epsilon_r = 42.979$; $\rho = 1000$ kg/m³
Ambient Temperature : 23.3°C; Liquid Temperature : 22.6°C

DASY5 Configuration:

- Probe: EX3DV4 - SN3985; ConvF(9.9, 9.9, 9.9) @ 836.4 MHz; Calibrated: 2023/07/10
- Sensor-Surface: 2mm (Mechanical Surface Detection)
- Electronics: DAE4 Sn755; Calibrated: 2023/03/23
- Phantom: SAM Right ; Type: QD000P40CD; Serial: TP:1502
- Measurement SW: DASY52, Version 52.8 (8); SEMCAD X Version 14.6.14 (7483)

-Area Scan (71x131x1): Interpolated grid: dx=1.500 mm, dy=1.500 mm
Maximum value of SAR (interpolated) = 0.319 W/kg

-Zoom Scan (5x5x7)/Cube 0: Measurement grid: dx=8mm, dy=8mm, dz=5mm
Reference Value = 14.00 V/m; Power Drift = 0.03 dB
Peak SAR (extrapolated) = 0.393 W/kg
SAR(1 g) = 0.235 W/kg; SAR(10 g) = 0.148 W/kg
Smallest distance from peaks to all points 3 dB below = 13.7 mm
Ratio of SAR at M2 to SAR at M1 = 62.4%
Maximum value of SAR (measured) = 0.310 W/kg

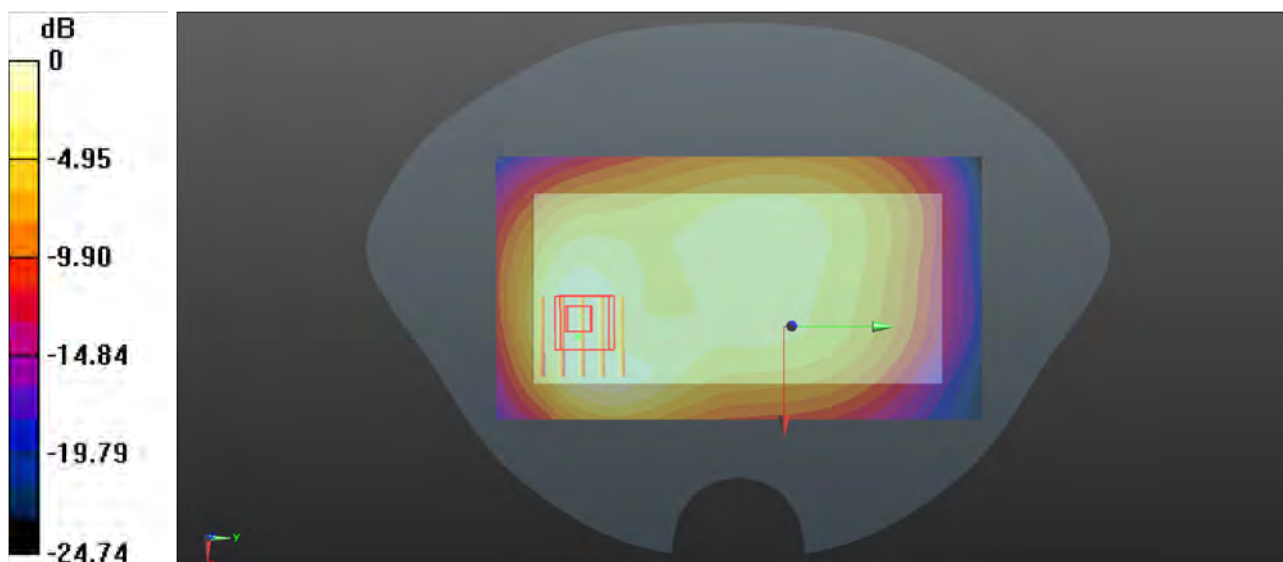

0 dB = 0.310 W/kg

P20 LTE 2_QPSK20M_Rear Face_1cm_Ch19100_50RB_OS25

Communication System: LTE_FDD; Frequency: 1900 MHz; Duty Cycle: 1:1

Medium: HSL1950_0123 Medium parameters used: $f = 1900$ MHz; $\sigma = 1.437$ S/m; $\epsilon_r = 39.445$; $\rho = 1000$ kg/m³

Ambient Temperature : 23.1°C; Liquid Temperature : 22.3°C

DASY5 Configuration:

- Probe: EX3DV4 - SN3985; ConvF(8.26, 8.26, 8.26) @ 1900 MHz; Calibrated: 2023/07/10
- Sensor-Surface: 2mm (Mechanical Surface Detection)
- Electronics: DAE4 Sn755; Calibrated: 2023/03/23
- Phantom: SAM Right ; Type: QD000P40CD; Serial: TP:1502
- Measurement SW: DASY52, Version 52.8 (8); SEMCAD X Version 14.6.14 (7483)

-Area Scan (71x71x1): Interpolated grid: dx=1.500 mm, dy=1.500 mm

Maximum value of SAR (interpolated) = 1.23 W/kg

-Zoom Scan (5x5x7)/Cube 0: Measurement grid: dx=8mm, dy=8mm, dz=5mm

Reference Value = 13.24 V/m; Power Drift = -0.02 dB

Peak SAR (extrapolated) = 1.53 W/kg

SAR(1 g) = 0.845 W/kg; SAR(10 g) = 0.457 W/kg

Smallest distance from peaks to all points 3 dB below = 10.7 mm

Ratio of SAR at M2 to SAR at M1 = 57.2%

Maximum value of SAR (measured) = 1.17 W/kg

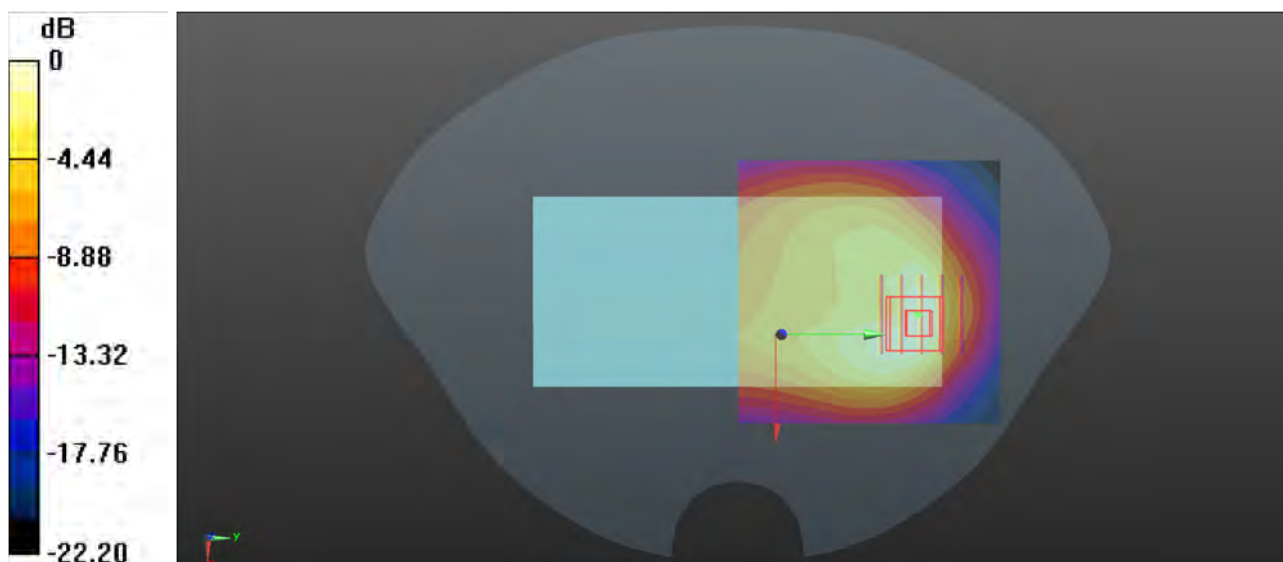

0 dB = 1.17 W/kg

P21 LTE 5_QPSK10M_Rear Face_1cm_Ch20450_1RB_OS49

Communication System: LTE_FDD; Frequency: 829 MHz; Duty Cycle: 1:1
Medium: HSL835_0111 Medium parameters used: $f = 829$ MHz; $\sigma = 0.942$ S/m; $\epsilon_r = 43.004$; $\rho = 1000$ kg/m³
Ambient Temperature : 23.3°C; Liquid Temperature : 22.6°C

DASY5 Configuration:

- Probe: EX3DV4 - SN3985; ConvF(9.9, 9.9, 9.9) @ 829 MHz; Calibrated: 2023/07/10
- Sensor-Surface: 2mm (Mechanical Surface Detection)
- Electronics: DAE4 Sn755; Calibrated: 2023/03/23
- Phantom: SAM Right ; Type: QD000P40CD; Serial: TP:1502
- Measurement SW: DASY52, Version 52.8 (8); SEMCAD X Version 14.6.14 (7483)

-Area Scan (71x131x1): Interpolated grid: dx=1.500 mm, dy=1.500 mm
Maximum value of SAR (interpolated) = 0.409 W/kg

-Zoom Scan (5x5x7)/Cube 0: Measurement grid: dx=8mm, dy=8mm, dz=5mm
Reference Value = 15.63 V/m; Power Drift = -0.01 dB
Peak SAR (extrapolated) = 0.507 W/kg
SAR(1 g) = 0.313 W/kg; SAR(10 g) = 0.197 W/kg
Smallest distance from peaks to all points 3 dB below = 16 mm
Ratio of SAR at M2 to SAR at M1 = 60.7%
Maximum value of SAR (measured) = 0.400 W/kg

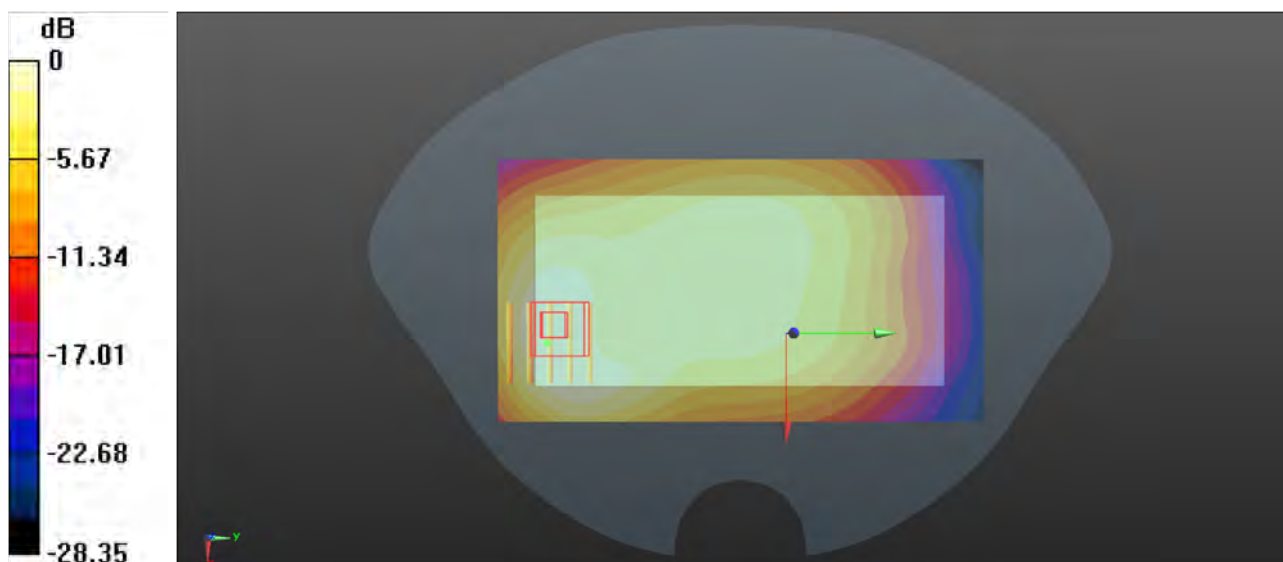

0 dB = 0.400 W/kg

P22 LTE 12_QPSK10M_Rear Face_1cm_Ch23130_1RB_OS0

Communication System: LTE_FDD; Frequency: 711 MHz; Duty Cycle: 1:1
Medium: HSL750_0112 Medium parameters used: $f = 711 \text{ MHz}$; $\sigma = 0.896 \text{ S/m}$; $\epsilon_r = 42.995$; $\rho = 1000 \text{ kg/m}^3$
Ambient Temperature : 23.4°C; Liquid Temperature : 22.5°C

DASY5 Configuration:

- Probe: EX3DV4 - SN3985; ConvF(10.3, 10.3, 10.3) @ 711 MHz; Calibrated: 2023/07/10
- Sensor-Surface: 2mm (Mechanical Surface Detection)
- Electronics: DAE4 Sn755; Calibrated: 2023/03/23
- Phantom: SAM Right ; Type: QD000P40CD; Serial: TP:1502
- Measurement SW: DASY52, Version 52.8 (8); SEMCAD X Version 14.6.14 (7483)

-Area Scan (71x131x1): Interpolated grid: $dx=1.500 \text{ mm}$, $dy=1.500 \text{ mm}$
Maximum value of SAR (interpolated) = 0.242 W/kg

-Zoom Scan (5x5x7)/Cube 0: Measurement grid: $dx=8\text{mm}$, $dy=8\text{mm}$, $dz=5\text{mm}$
Reference Value = 13.50 V/m; Power Drift = -0.06 dB
Peak SAR (extrapolated) = 0.290 W/kg
SAR(1 g) = 0.176 W/kg; SAR(10 g) = 0.119 W/kg
Smallest distance from peaks to all points 3 dB below = 17 mm
Ratio of SAR at M2 to SAR at M1 = 62.9%
Maximum value of SAR (measured) = 0.228 W/kg

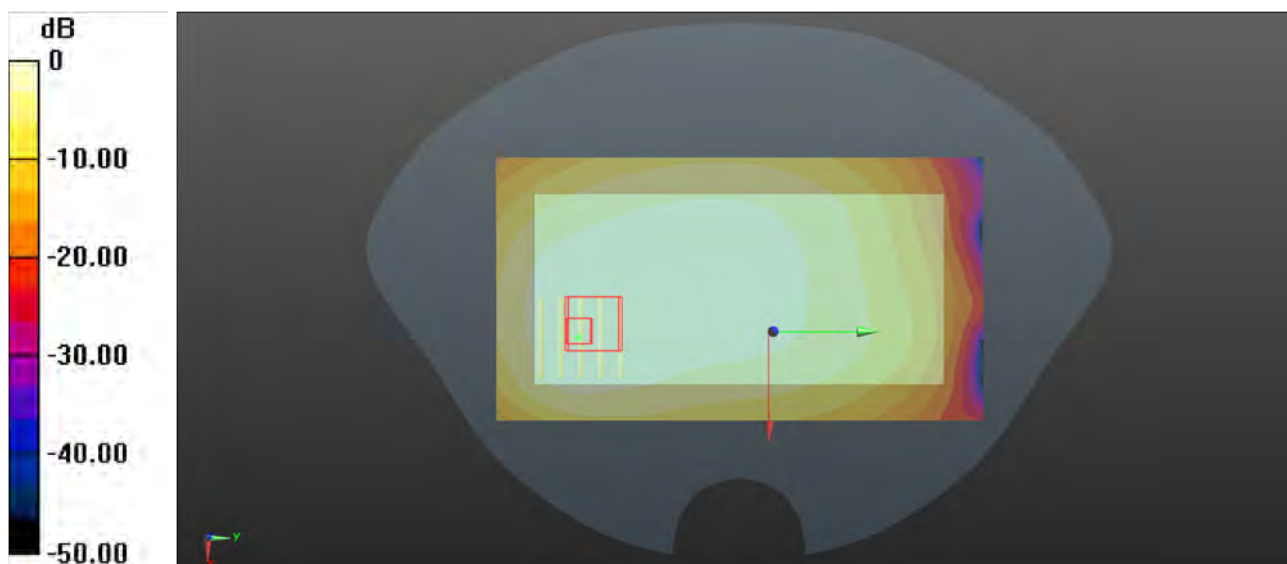

0 dB = 0.228 W/kg

P23 LTE 13_QPSK10M_Rear Face_1cm_Ch23230_1RB_OS49

Communication System: LTE_FDD; Frequency: 782 MHz; Duty Cycle: 1:1
Medium: HSL750_0112 Medium parameters used: $f = 782$ MHz; $\sigma = 0.918$ S/m; $\epsilon_r = 42.794$; $\rho = 1000$ kg/m³
Ambient Temperature : 23.4°C; Liquid Temperature : 22.5°C

DASY5 Configuration:

- Probe: EX3DV4 - SN3985; ConvF(10.3, 10.3, 10.3) @ 782 MHz; Calibrated: 2023/07/10
- Sensor-Surface: 2mm (Mechanical Surface Detection)
- Electronics: DAE4 Sn755; Calibrated: 2023/03/23
- Phantom: SAM Right ; Type: QD000P40CD; Serial: TP:1502
- Measurement SW: DASY52, Version 52.8 (8); SEMCAD X Version 14.6.14 (7483)

-Area Scan (71x131x1): Interpolated grid: dx=1.500 mm, dy=1.500 mm
Maximum value of SAR (interpolated) = 0.222 W/kg

-Zoom Scan (5x5x7)/Cube 0: Measurement grid: dx=8mm, dy=8mm, dz=5mm
Reference Value = 11.98 V/m; Power Drift = 0.07 dB
Peak SAR (extrapolated) = 0.277 W/kg
SAR(1 g) = 0.167 W/kg; SAR(10 g) = 0.108 W/kg
Smallest distance from peaks to all points 3 dB below = 14.8 mm
Ratio of SAR at M2 to SAR at M1 = 62.1%
Maximum value of SAR (measured) = 0.215 W/kg

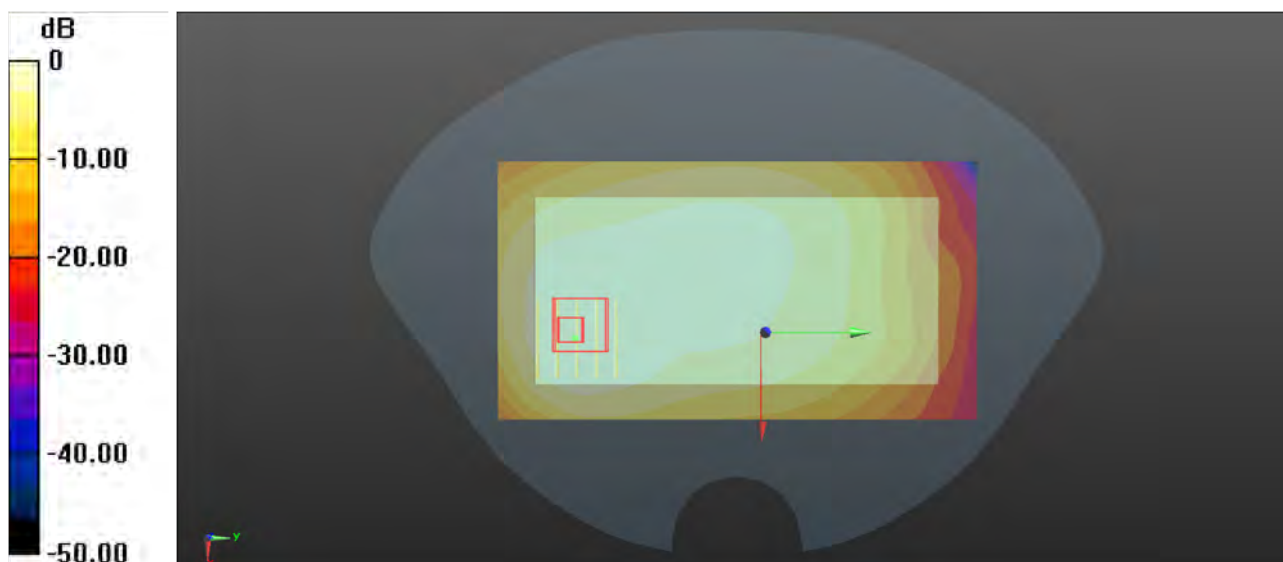

0 dB = 0.215 W/kg

P24 LTE 66_QPSK20M_Rear Face_1cm_Ch132322_1RB_OS99

Communication System: LTE_FDD; Frequency: 1745 MHz; Duty Cycle: 1:1

Medium: HSL1750_0124 Medium parameters used: $f = 1745$ MHz; $\sigma = 1.364$ S/m; $\epsilon_r = 40.395$; $\rho = 1000$ kg/m³

Ambient Temperature : 23.3°C; Liquid Temperature : 22.4°C

DASY5 Configuration:

- Probe: EX3DV4 - SN3985; ConvF(8.53, 8.53, 8.53) @ 1745 MHz; Calibrated: 2023/07/10
- Sensor-Surface: 2mm (Mechanical Surface Detection)
- Electronics: DAE4 Sn755; Calibrated: 2023/03/23
- Phantom: SAM Right ; Type: QD000P40CD; Serial: TP:1502
- Measurement SW: DASY52, Version 52.8 (8); SEMCAD X Version 14.6.14 (7483)

-Area Scan (71x131x1): Interpolated grid: dx=1.500 mm, dy=1.500 mm

Maximum value of SAR (interpolated) = 0.735 W/kg

-Zoom Scan (5x5x7)/Cube 0: Measurement grid: dx=8mm, dy=8mm, dz=5mm

Reference Value = 11.75 V/m; Power Drift = -0.02 dB

Peak SAR (extrapolated) = 0.910 W/kg

SAR(1 g) = 0.512 W/kg; SAR(10 g) = 0.290 W/kg

Smallest distance from peaks to all points 3 dB below = 11.5 mm

Ratio of SAR at M2 to SAR at M1 = 56%

Maximum value of SAR (measured) = 0.708 W/kg

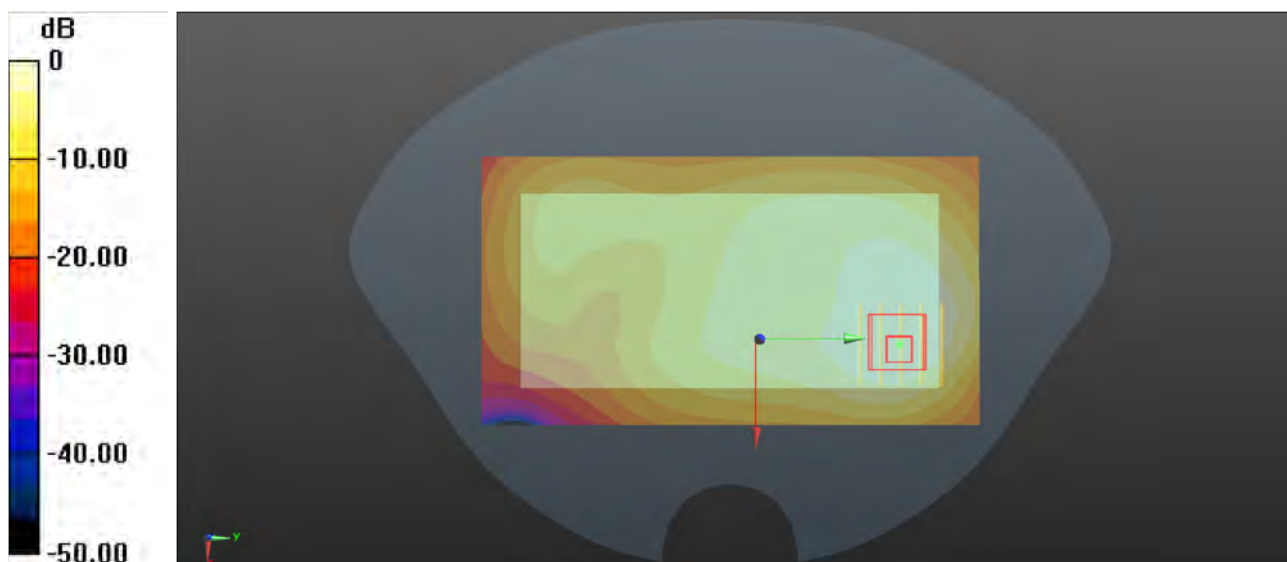

0 dB = 0.708 W/kg

P25 WLAN2.4G_802.11b_Rear Face_1cm_Ch6

Communication System: 802.11b; Frequency: 2437 MHz; Duty Cycle: 1:1.027

Medium: HSL2450_0113 Medium parameters used: $f = 2437$ MHz; $\sigma = 1.869$ S/m; $\epsilon_r = 39.644$; $\rho = 1000$ kg/m³

Ambient Temperature : 23.2°C; Liquid Temperature : 22.7°C

DASY5 Configuration:

- Probe: EX3DV4 - SN3985; ConvF(7.8, 7.8, 7.8) @ 2437 MHz; Calibrated: 2023/07/10
- Sensor-Surface: 2mm (Mechanical Surface Detection)
- Electronics: DAE4 Sn755; Calibrated: 2023/03/23
- Phantom: SAM Right ; Type: QD000P40CD; Serial: TP:1502
- Measurement SW: DASY52, Version 52.8 (8); SEMCAD X Version 14.6.14 (7483)

-Area Scan (81x81x1): Interpolated grid: dx=1.200 mm, dy=1.200 mm

Maximum value of SAR (interpolated) = 0.751 W/kg

-Zoom Scan (7x7x7)/Cube 0: Measurement grid: dx=5mm, dy=5mm, dz=5mm

Reference Value = 2.452 V/m; Power Drift = -0.05 dB

Peak SAR (extrapolated) = 1.08 W/kg

SAR(1 g) = 0.451 W/kg; SAR(10 g) = 0.196 W/kg

Smallest distance from peaks to all points 3 dB below = 7 mm

Ratio of SAR at M2 to SAR at M1 = 43.9%

Maximum value of SAR (measured) = 0.685 W/kg

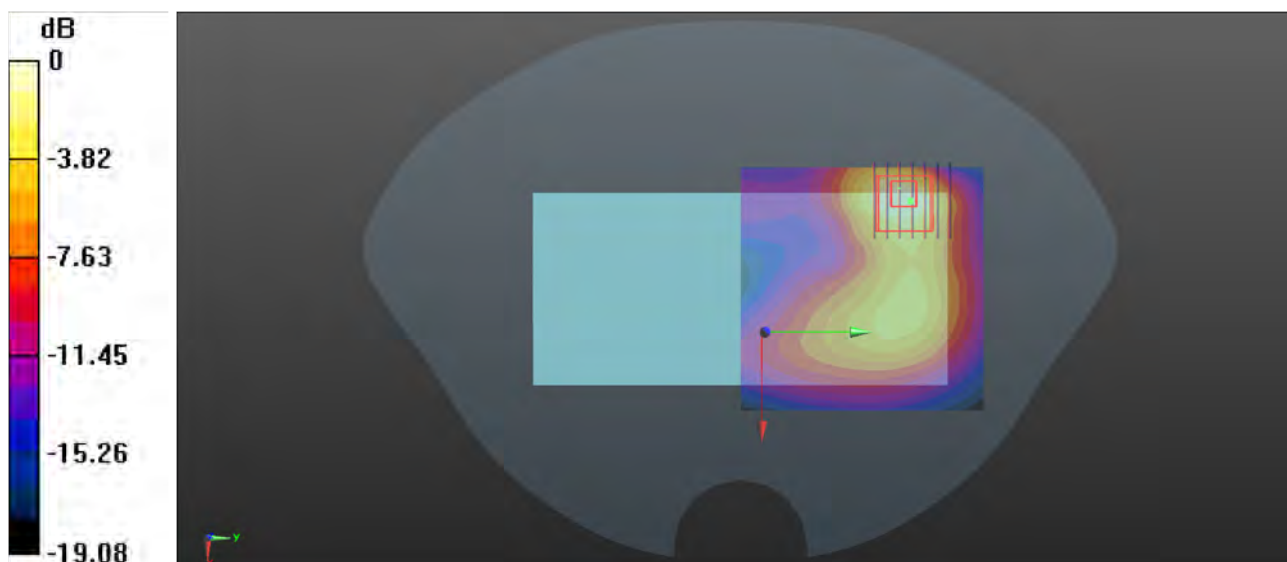

0 dB = 0.685 W/kg

P26 WLAN5G_802.11n-HT20_Rear Face_1cm_Ch40

Communication System: 802.11n_HT20; Frequency: 5200 MHz; Duty Cycle: 1:1.019
Medium: HSL5G_0125 Medium parameters used: $f = 5200$ MHz; $\sigma = 4.51$ S/m; $\epsilon_r = 35.327$; $\rho = 1000$ kg/m³
Ambient Temperature : 23.7°C; Liquid Temperature : 22.5°C

DASY5 Configuration:

- Probe: EX3DV4 - SN3985; ConvF(5.6, 5.6, 5.6) @ 5200 MHz; Calibrated: 2023/07/10
- Sensor-Surface: 2mm (Mechanical Surface Detection)
- Electronics: DAE4 Sn755; Calibrated: 2023/03/23
- Phantom: SAM Right ; Type: QD000P40CD; Serial: TP:1502
- Measurement SW: DASY52, Version 52.8 (8); SEMCAD X Version 14.6.14 (7483)

-Area Scan (101x101x1): Interpolated grid: dx=1.000 mm, dy=1.000 mm
Maximum value of SAR (interpolated) = 1.55 W/kg

-Zoom Scan (7x7x12)/Cube 0: Measurement grid: dx=4mm, dy=4mm, dz=2mm
Reference Value = 1.616 V/m; Power Drift = -0.08 dB
Peak SAR (extrapolated) = 3.05 W/kg
SAR(1 g) = 0.878 W/kg; SAR(10 g) = 0.297 W/kg
Smallest distance from peaks to all points 3 dB below = 8.2 mm
Ratio of SAR at M2 to SAR at M1 = 57.9%
Maximum value of SAR (measured) = 1.70 W/kg



0 dB = 1.70 W/kg

P27 WLAN5G_802.11a_Rear Face_1cm_Ch60

Communication System: 802.11a; Frequency: 5300 MHz; Duty Cycle: 1:1.018

Medium: HSL5G_0125 Medium parameters used: $f = 5300$ MHz; $\sigma = 4.664$ S/m; $\epsilon_r = 35.102$; $\rho = 1000$ kg/m³

Ambient Temperature : 23.7°C; Liquid Temperature : 22.5°C

DASY5 Configuration:

- Probe: EX3DV4 - SN3985; ConvF(5.6, 5.6, 5.6) @ 5300 MHz; Calibrated: 2023/07/10
- Sensor-Surface: 2mm (Mechanical Surface Detection)
- Electronics: DAE4 Sn755; Calibrated: 2023/03/23
- Phantom: SAM Right ; Type: QD000P40CD; Serial: TP:1502
- Measurement SW: DASY52, Version 52.8 (8); SEMCAD X Version 14.6.14 (7483)

-Area Scan (101x101x1): Interpolated grid: dx=1.000 mm, dy=1.000 mm

Maximum value of SAR (interpolated) = 1.97 W/kg

-Zoom Scan (7x7x12)/Cube 0: Measurement grid: dx=4mm, dy=4mm, dz=2mm

Reference Value = 1.822 V/m; Power Drift = -0.04 dB

Peak SAR (extrapolated) = 3.65 W/kg

SAR(1 g) = 0.992 W/kg; SAR(10 g) = 0.330 W/kg

Smallest distance from peaks to all points 3 dB below = 7.6 mm

Ratio of SAR at M2 to SAR at M1 = 56.2%

Maximum value of SAR (measured) = 1.91 W/kg

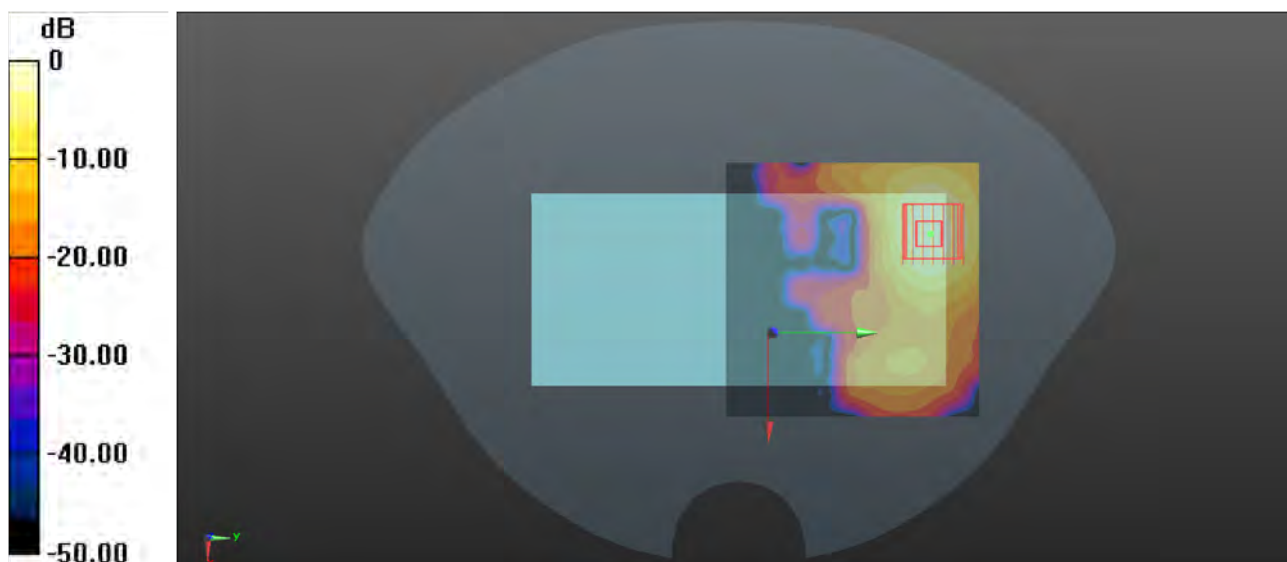

0 dB = 1.91 W/kg

P28 WLAN5G_802.11a_Rear Face_1cm_Ch140

Communication System: 802.11a; Frequency: 5700 MHz; Duty Cycle: 1:1.018

Medium: HSL5G_0126 Medium parameters used: $f = 5700$ MHz; $\sigma = 5.096$ S/m; $\epsilon_r = 35.504$; $\rho = 1000$ kg/m³

Ambient Temperature : 23.3°C; Liquid Temperature : 22.5°C

DASY5 Configuration:

- Probe: EX3DV4 - SN3985; ConvF(5.08, 5.08, 5.08) @ 5700 MHz; Calibrated: 2023/07/10
- Sensor-Surface: 2mm (Mechanical Surface Detection)
- Electronics: DAE4 Sn755; Calibrated: 2023/03/23
- Phantom: SAM Right ; Type: QD000P40CD; Serial: TP:1502
- Measurement SW: DASY52, Version 52.8 (8); SEMCAD X Version 14.6.14 (7483)

-Area Scan (101x101x1): Interpolated grid: dx=1.000 mm, dy=1.000 mm

Maximum value of SAR (interpolated) = 0.851 W/kg

-Zoom Scan (7x7x12)/Cube 0: Measurement grid: dx=4mm, dy=4mm, dz=2mm

Reference Value = 0 V/m; Power Drift = 0.09 dB

Peak SAR (extrapolated) = 1.76 W/kg

SAR(1 g) = 0.432 W/kg; SAR(10 g) = 0.138 W/kg

Smallest distance from peaks to all points 3 dB below = 8.2 mm

Ratio of SAR at M2 to SAR at M1 = 52.1%

Maximum value of SAR (measured) = 0.850 W/kg

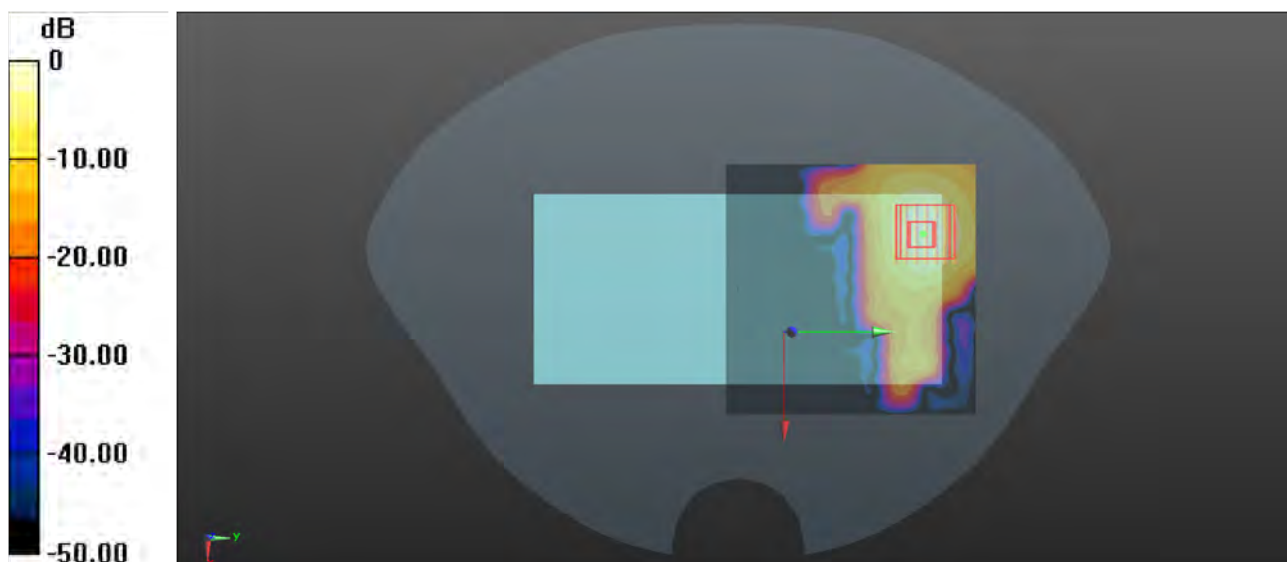

0 dB = 0.850 W/kg

P29 WLAN5G_802.11ac-VHT20_Rear Face_1cm_Ch149

Communication System: 802.11ac_VHT20; Frequency: 5745 MHz; Duty Cycle: 1:1.038
Medium: HSL5G_0126 Medium parameters used: $f = 5745$ MHz; $\sigma = 5.155$ S/m; $\epsilon_r = 34.384$; $\rho = 1000$ kg/m³
Ambient Temperature : 23.3°C; Liquid Temperature : 22.5°C

DASY5 Configuration:

- Probe: EX3DV4 - SN3985; ConvF(5.16, 5.16, 5.16) @ 5745 MHz; Calibrated: 2023/07/10
- Sensor-Surface: 2mm (Mechanical Surface Detection)
- Electronics: DAE4 Sn755; Calibrated: 2023/03/23
- Phantom: SAM Right ; Type: QD000P40CD; Serial: TP:1502
- Measurement SW: DASY52, Version 52.8 (8); SEMCAD X Version 14.6.14 (7483)

-Area Scan (101x91x1): Interpolated grid: dx=1.000 mm, dy=1.000 mm
Maximum value of SAR (interpolated) = 0.850 W/kg

-Zoom Scan (7x7x12)/Cube 0: Measurement grid: dx=4mm, dy=4mm, dz=2mm
Reference Value = 1.087 V/m; Power Drift = -0.02 dB
Peak SAR (extrapolated) = 1.70 W/kg
SAR(1 g) = 0.424 W/kg; SAR(10 g) = 0.137 W/kg
Smallest distance from peaks to all points 3 dB below = 8.2 mm
Ratio of SAR at M2 to SAR at M1 = 51.9%
Maximum value of SAR (measured) = 0.840 W/kg

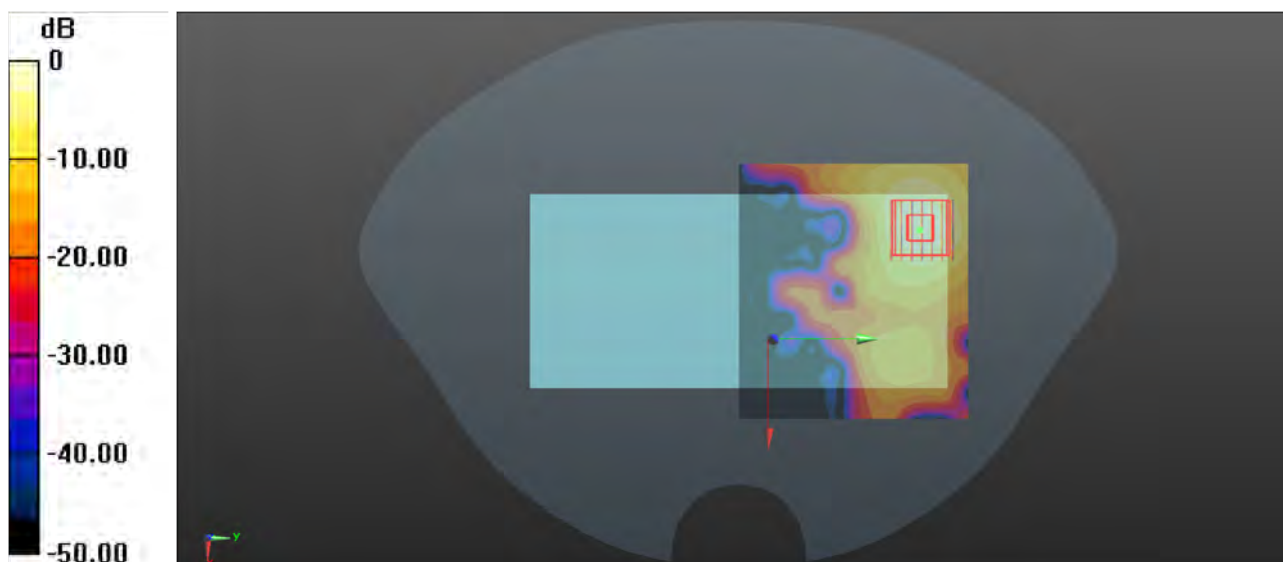

0 dB = 0.840 W/kg

P30 BT_GFSK_Rear Face_1cm_Ch0

Communication System: BT; Frequency: 2402 MHz; Duty Cycle: 1:1.295

Medium: HSL2450_0113 Medium parameters used: $f = 2402$ MHz; $\sigma = 1.843$ S/m; $\epsilon_r = 39.707$; $\rho = 1000$ kg/m³

Ambient Temperature : 23.2°C; Liquid Temperature : 22.7°C

DASY5 Configuration:

- Probe: EX3DV4 - SN3985; ConvF(7.8, 7.8, 7.8) @ 2402 MHz; Calibrated: 2023/07/10
- Sensor-Surface: 2mm (Mechanical Surface Detection)
- Electronics: DAE4 Sn755; Calibrated: 2023/03/23
- Phantom: SAM Right ; Type: QD000P40CD; Serial: TP:1502
- Measurement SW: DASY52, Version 52.8 (8); SEMCAD X Version 14.6.14 (7483)

-Area Scan (81x81x1): Interpolated grid: dx=1.200 mm, dy=1.200 mm

Maximum value of SAR (interpolated) = 0.131 W/kg

-Zoom Scan (7x7x7)/Cube 0: Measurement grid: dx=5mm, dy=5mm, dz=5mm

Reference Value = 0.9320 V/m; Power Drift = 0.09 dB

Peak SAR (extrapolated) = 0.174 W/kg

SAR(1 g) = 0.073 W/kg; SAR(10 g) = 0.031 W/kg

Smallest distance from peaks to all points 3 dB below = 8 mm

Ratio of SAR at M2 to SAR at M1 = 44.4%

Maximum value of SAR (measured) = 0.116 W/kg

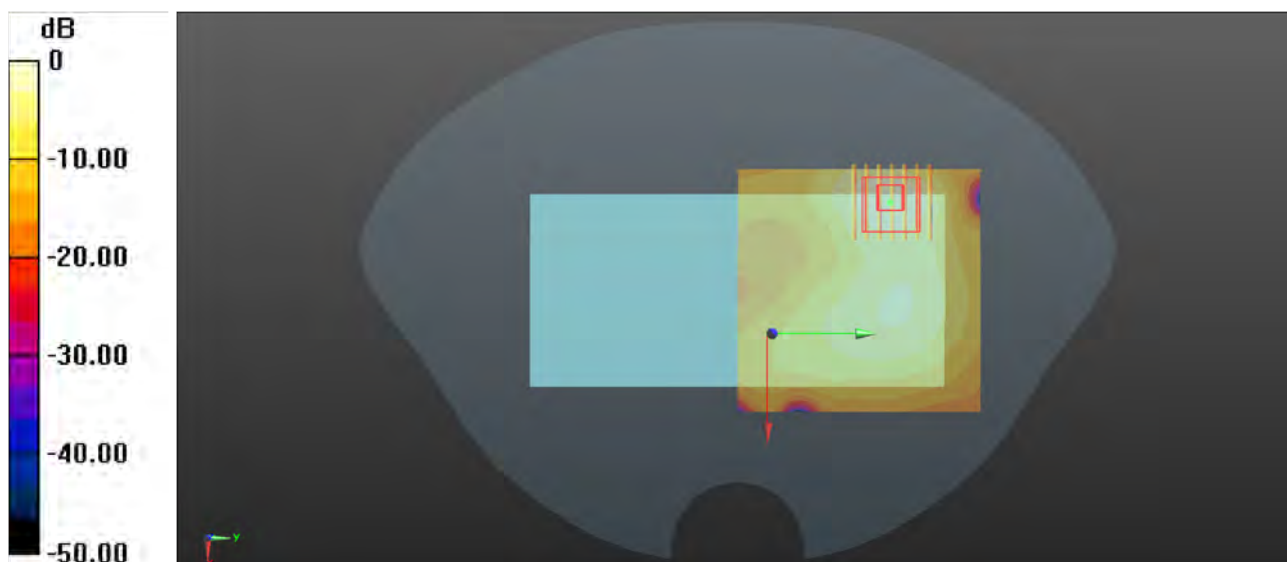

0 dB = 0.116 W/kg

P31 GSM850_GPRS 4Tx Slot_Rear Face_1cm_Ch251

Communication System: GPRS 4Tx Slot; Frequency: 848.8 MHz; Duty Cycle: 1:2.08

Medium: HSL835_0111 Medium parameters used: $f = 849$ MHz; $\sigma = 0.95$ S/m; $\epsilon_r = 42.941$; $\rho = 1000$ kg/m³

Ambient Temperature : 23.3°C; Liquid Temperature : 22.6°C

DASY5 Configuration:

- Probe: EX3DV4 - SN3985; ConvF(9.9, 9.9, 9.9) @ 848.8 MHz; Calibrated: 2023/07/10
- Sensor-Surface: 2mm (Mechanical Surface Detection)
- Electronics: DAE4 Sn755; Calibrated: 2023/03/23
- Phantom: SAM Right ; Type: QD000P40CD; Serial: TP:1502
- Measurement SW: DASY52, Version 52.8 (8); SEMCAD X Version 14.6.14 (7483)

-Area Scan (71x131x1): Interpolated grid: dx=1.500 mm, dy=1.500 mm

Maximum value of SAR (interpolated) = 0.386 W/kg

-Zoom Scan (5x5x7)/Cube 0: Measurement grid: dx=8mm, dy=8mm, dz=5mm

Reference Value = 11.96 V/m; Power Drift = -0.02 dB

Peak SAR (extrapolated) = 0.330 W/kg

SAR(1 g) = 0.203 W/kg; SAR(10 g) = 0.123 W/kg

Smallest distance from peaks to all points 3 dB below = 17.3 mm

Ratio of SAR at M2 to SAR at M1 = 61.4%

Maximum value of SAR (measured) = 0.265 W/kg

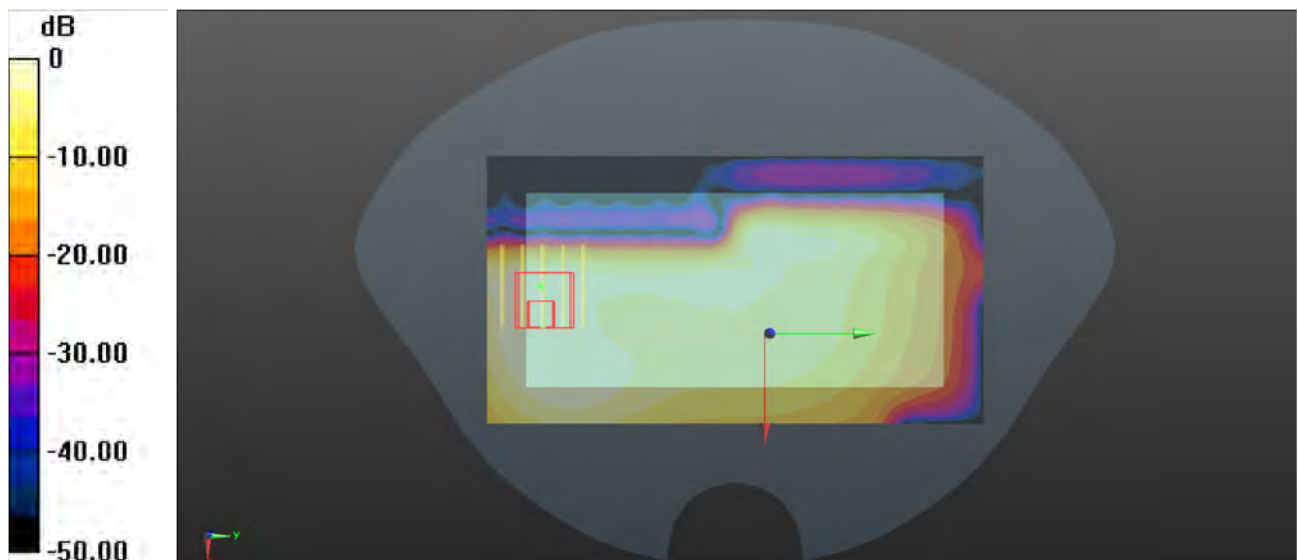

0 dB = 0.265 W/kg

P32 GSM1900_GPRS 4Tx Slot_Top Side_1cm_Ch810

Communication System: GPRS 4Tx Slot; Frequency: 1909.8 MHz; Duty Cycle: 1:2.08
Medium: HSL1950_0122 Medium parameters used: $f = 1910$ MHz; $\sigma = 1.45$ S/m; $\epsilon_r = 39.477$; $\rho = 1000$ kg/m³
Ambient Temperature : 23.5°C; Liquid Temperature : 22.6°C

DASY5 Configuration:

- Probe: EX3DV4 - SN3985; ConvF(8.26, 8.26, 8.26) @ 1909.8 MHz; Calibrated: 2023/07/10
- Sensor-Surface: 2mm (Mechanical Surface Detection)
- Electronics: DAE4 Sn755; Calibrated: 2023/03/23
- Phantom: SAM Right ; Type: QD000P40CD; Serial: TP:1502
- Measurement SW: DASY52, Version 52.8 (8); SEMCAD X Version 14.6.14 (7483)

-Area Scan (31x71x1): Interpolated grid: dx=1.500 mm, dy=1.500 mm
Maximum value of SAR (interpolated) = 0.889 W/kg

-Zoom Scan (5x5x7)/Cube 0: Measurement grid: dx=8mm, dy=8mm, dz=5mm
Reference Value = 17.15 V/m; Power Drift = -0.06 dB
Peak SAR (extrapolated) = 1.40 W/kg
SAR(1 g) = 0.609 W/kg; SAR(10 g) = 0.275 W/kg
Smallest distance from peaks to all points 3 dB below = 3.2 mm
Ratio of SAR at M2 to SAR at M1 = 55.2%
Maximum value of SAR (measured) = 0.866 W/kg

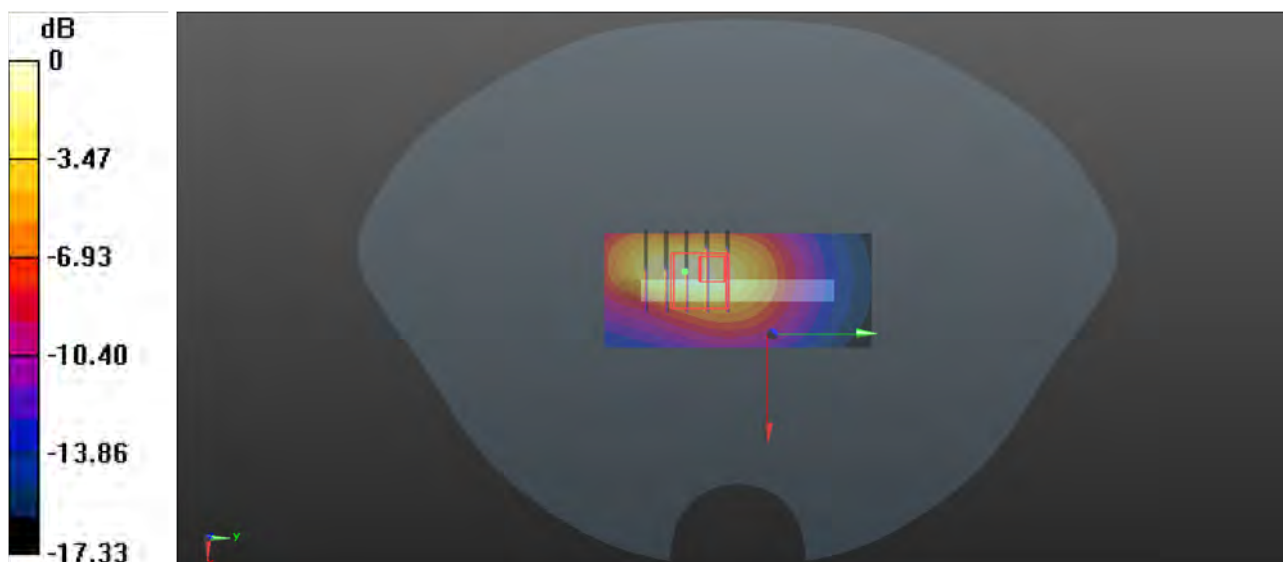

0 dB = 0.866 W/kg

P33 WCDMA II_RMC12.2K_Top Side_1.9cm_Ch9262

Communication System: WCDMA; Frequency: 1852.4 MHz; Duty Cycle: 1:1
Medium: HSL1950_0122 Medium parameters used: $f = 1852.4$ MHz; $\sigma = 1.411$ S/m; $\epsilon_r = 39.549$; $\rho = 1000$ kg/m³
Ambient Temperature : 23.5°C; Liquid Temperature : 22.6°C

DASY5 Configuration:

- Probe: EX3DV4 - SN3985; ConvF(8.26, 8.26, 8.26) @ 1852.4 MHz; Calibrated: 2023/07/10
- Sensor-Surface: 2mm (Mechanical Surface Detection)
- Electronics: DAE4 Sn755; Calibrated: 2023/03/23
- Phantom: SAM Right ; Type: QD000P40CD; Serial: TP:1502
- Measurement SW: DASY52, Version 52.8 (8); SEMCAD X Version 14.6.14 (7483)

-Area Scan (31x71x1): Interpolated grid: dx=1.500 mm, dy=1.500 mm
Maximum value of SAR (interpolated) = 0.776 W/kg

-Zoom Scan (5x5x7)/Cube 0: Measurement grid: dx=8mm, dy=8mm, dz=5mm
Reference Value = 20.52 V/m; Power Drift = 0.06 dB
Peak SAR (extrapolated) = 0.938 W/kg
SAR(1 g) = 0.585 W/kg; SAR(10 g) = 0.347 W/kg
Smallest distance from peaks to all points 3 dB below = 15.8 mm
Ratio of SAR at M2 to SAR at M1 = 62.2%
Maximum value of SAR (measured) = 0.773 W/kg

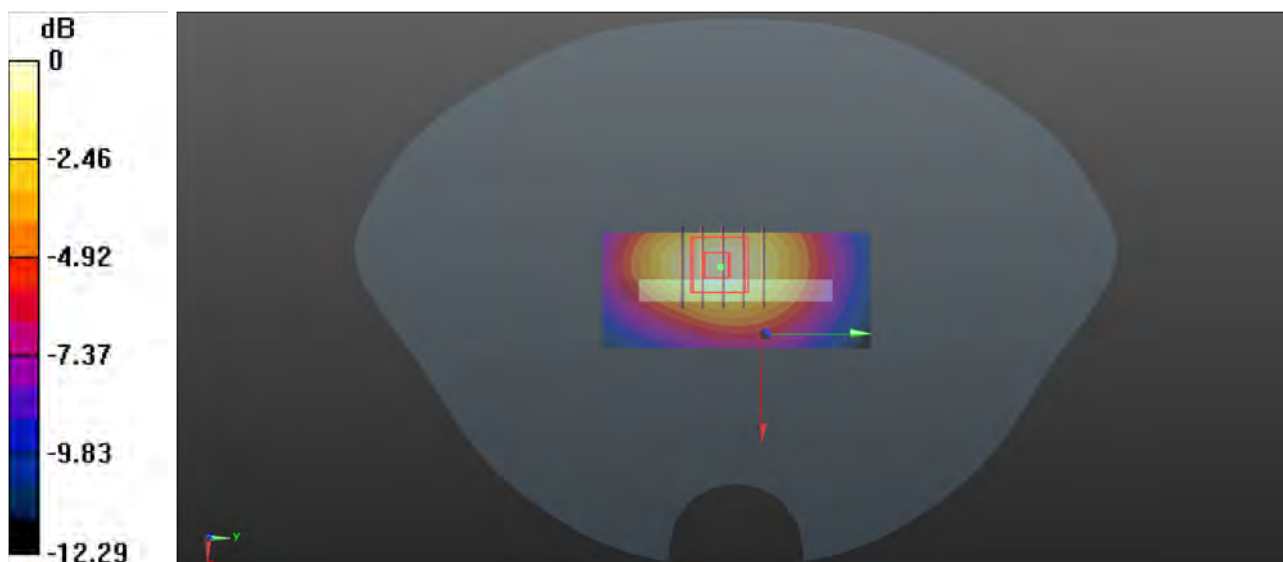

0 dB = 0.773 W/kg

P34 WCDMA V_RMC12.2K_Rear Face_1cm_Ch4182

Communication System: WCDMA; Frequency: 836.4 MHz; Duty Cycle: 1:1
Medium: HSL835_0111 Medium parameters used: $f = 836.4$ MHz; $\sigma = 0.945$ S/m; $\epsilon_r = 42.979$; $\rho = 1000$ kg/m³
Ambient Temperature : 23.3°C; Liquid Temperature : 22.6°C

DASY5 Configuration:

- Probe: EX3DV4 - SN3985; ConvF(9.9, 9.9, 9.9) @ 836.4 MHz; Calibrated: 2023/07/10
- Sensor-Surface: 2mm (Mechanical Surface Detection)
- Electronics: DAE4 Sn755; Calibrated: 2023/03/23
- Phantom: SAM Right ; Type: QD000P40CD; Serial: TP:1502
- Measurement SW: DASY52, Version 52.8 (8); SEMCAD X Version 14.6.14 (7483)

-Area Scan (71x131x1): Interpolated grid: dx=1.500 mm, dy=1.500 mm
Maximum value of SAR (interpolated) = 0.319 W/kg

-Zoom Scan (5x5x7)/Cube 0: Measurement grid: dx=8mm, dy=8mm, dz=5mm
Reference Value = 14.00 V/m; Power Drift = 0.03 dB
Peak SAR (extrapolated) = 0.393 W/kg
SAR(1 g) = 0.235 W/kg; SAR(10 g) = 0.148 W/kg
Smallest distance from peaks to all points 3 dB below = 13.7 mm
Ratio of SAR at M2 to SAR at M1 = 62.4%
Maximum value of SAR (measured) = 0.310 W/kg

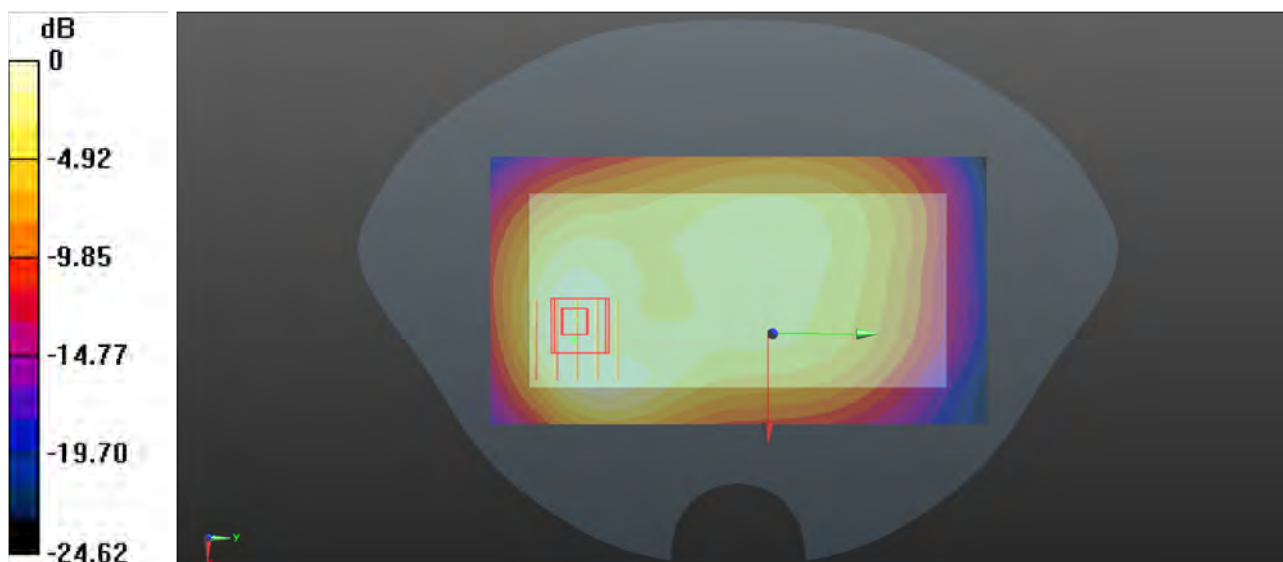

0 dB = 0.310 W/kg

P35 LTE 2_QPSK20M_Top Side_1cm_Ch18900_50RB_OS25

Communication System: LTE_FDD; Frequency: 1880 MHz; Duty Cycle: 1:1
Medium: HSL1950_0123 Medium parameters used: $f = 1880$ MHz; $\sigma = 1.424$ S/m; $\epsilon_r = 39.46$; $\rho = 1000$ kg/m³
Ambient Temperature : 23.1°C; Liquid Temperature : 22.3°C

DASY5 Configuration:

- Probe: EX3DV4 - SN3985; ConvF(8.26, 8.26, 8.26) @ 1880 MHz; Calibrated: 2023/07/10
- Sensor-Surface: 2mm (Mechanical Surface Detection)
- Electronics: DAE4 Sn755; Calibrated: 2023/03/23
- Phantom: SAM Right ; Type: QD000P40CD; Serial: TP:1502
- Measurement SW: DASY52, Version 52.8 (8); SEMCAD X Version 14.6.14 (7483)

-Area Scan (41x71x1): Interpolated grid: dx=1.500 mm, dy=1.500 mm
Maximum value of SAR (interpolated) = 0.842 W/kg

-Zoom Scan (5x5x7)/Cube 0: Measurement grid: dx=8mm, dy=8mm, dz=5mm
Reference Value = 21.24 V/m; Power Drift = 0.07 dB
Peak SAR (extrapolated) = 1.13 W/kg
SAR(1 g) = 0.639 W/kg; SAR(10 g) = 0.332 W/kg
Smallest distance from peaks to all points 3 dB below = 9.6 mm
Ratio of SAR at M2 to SAR at M1 = 57.8%
Maximum value of SAR (measured) = 0.888 W/kg

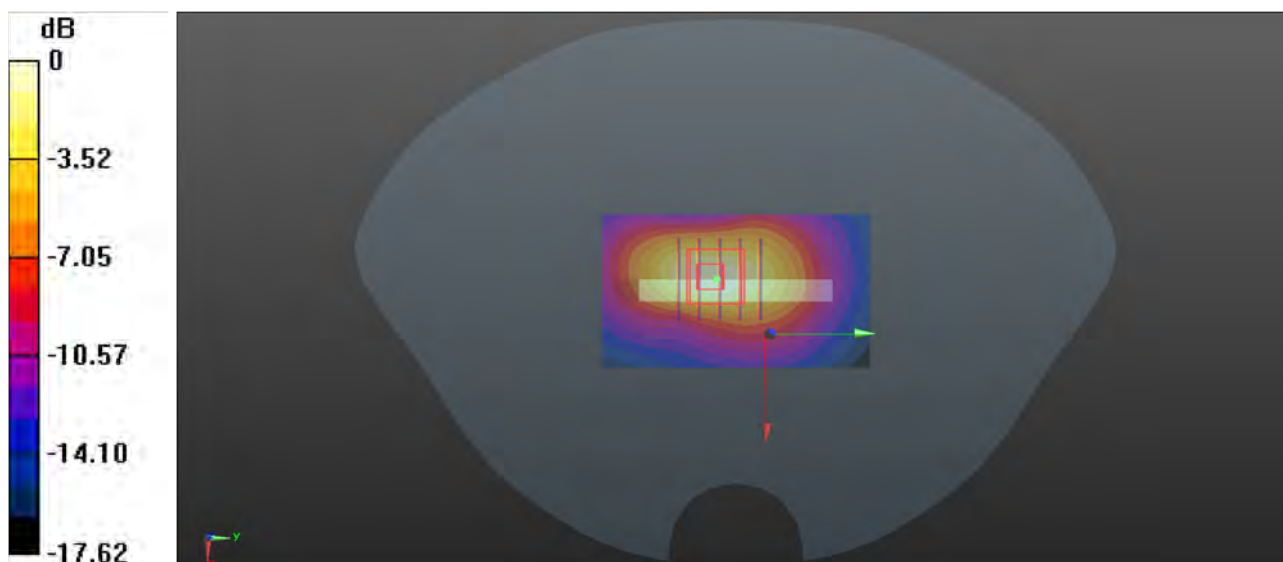

0 dB = 0.888 W/kg

P36 LTE 5_QPSK10M_Rear Face_1cm_Ch20450_1RB_OS49

Communication System: LTE_FDD; Frequency: 829 MHz; Duty Cycle: 1:1
Medium: HSL835_0111 Medium parameters used: $f = 829$ MHz; $\sigma = 0.942$ S/m; $\epsilon_r = 43.004$; $\rho = 1000$ kg/m³
Ambient Temperature : 23.3°C; Liquid Temperature : 22.6°C

DASY5 Configuration:

- Probe: EX3DV4 - SN3985; ConvF(9.9, 9.9, 9.9) @ 829 MHz; Calibrated: 2023/07/10
- Sensor-Surface: 2mm (Mechanical Surface Detection)
- Electronics: DAE4 Sn755; Calibrated: 2023/03/23
- Phantom: SAM Right ; Type: QD000P40CD; Serial: TP:1502
- Measurement SW: DASY52, Version 52.8 (8); SEMCAD X Version 14.6.14 (7483)

-Area Scan (71x131x1): Interpolated grid: dx=1.500 mm, dy=1.500 mm
Maximum value of SAR (interpolated) = 0.409 W/kg

-Zoom Scan (5x5x7)/Cube 0: Measurement grid: dx=8mm, dy=8mm, dz=5mm
Reference Value = 15.63 V/m; Power Drift = -0.01 dB
Peak SAR (extrapolated) = 0.507 W/kg
SAR(1 g) = 0.313 W/kg; SAR(10 g) = 0.197 W/kg
Smallest distance from peaks to all points 3 dB below = 16 mm
Ratio of SAR at M2 to SAR at M1 = 60.7%
Maximum value of SAR (measured) = 0.400 W/kg

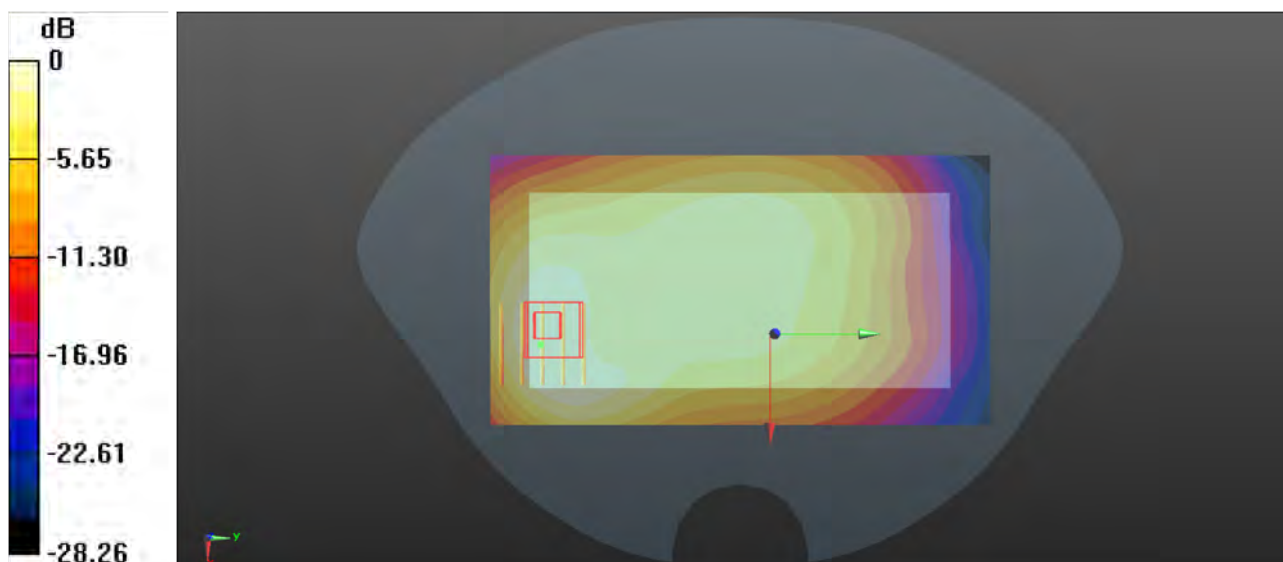

0 dB = 0.400 W/kg

P37 LTE 12_QPSK10M_Rear Face_1cm_Ch23130_1RB_OS0

Communication System: LTE_FDD; Frequency: 711 MHz; Duty Cycle: 1:1
Medium: HSL750_0112 Medium parameters used: $f = 711$ MHz; $\sigma = 0.896$ S/m; $\epsilon_r = 42.995$; $\rho = 1000$ kg/m³
Ambient Temperature : 23.4°C; Liquid Temperature : 22.5°C

DASY5 Configuration:

- Probe: EX3DV4 - SN3985; ConvF(10.3, 10.3, 10.3) @ 711 MHz; Calibrated: 2023/07/10
- Sensor-Surface: 2mm (Mechanical Surface Detection)
- Electronics: DAE4 Sn755; Calibrated: 2023/03/23
- Phantom: SAM Right ; Type: QD000P40CD; Serial: TP:1502
- Measurement SW: DASY52, Version 52.8 (8); SEMCAD X Version 14.6.14 (7483)

-Area Scan (71x131x1): Interpolated grid: dx=1.500 mm, dy=1.500 mm
Maximum value of SAR (interpolated) = 0.242 W/kg

-Zoom Scan (5x5x7)/Cube 0: Measurement grid: dx=8mm, dy=8mm, dz=5mm
Reference Value = 13.50 V/m; Power Drift = -0.06 dB
Peak SAR (extrapolated) = 0.290 W/kg
SAR(1 g) = 0.176 W/kg; SAR(10 g) = 0.119 W/kg
Smallest distance from peaks to all points 3 dB below = 17 mm
Ratio of SAR at M2 to SAR at M1 = 62.9%
Maximum value of SAR (measured) = 0.228 W/kg

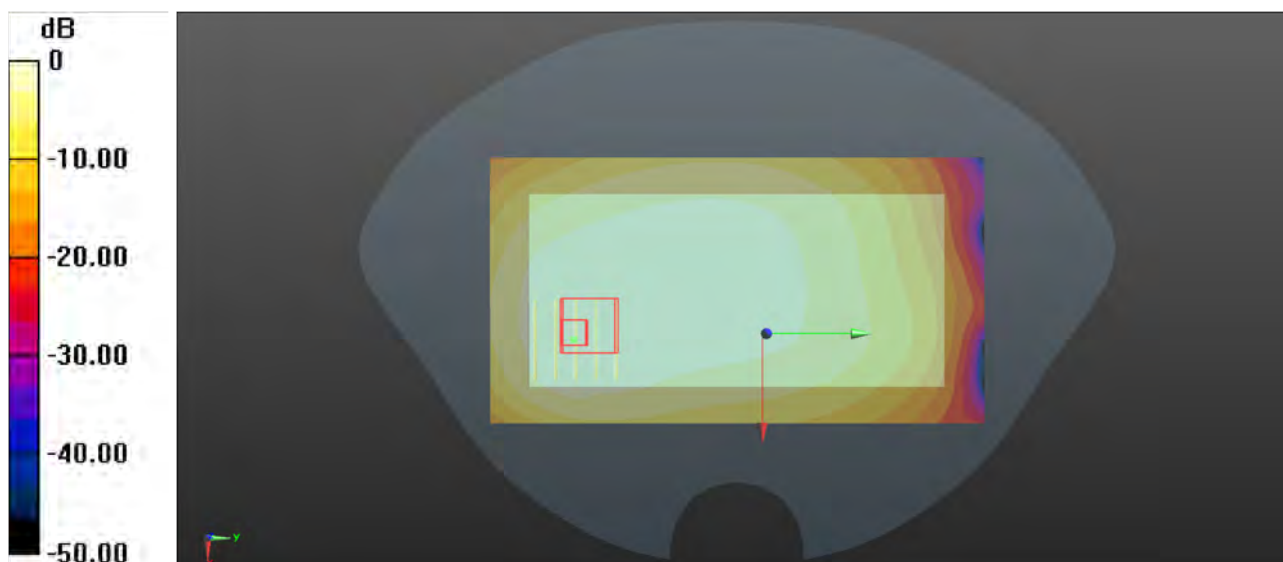

0 dB = 0.228 W/kg

P38 LTE 13_QPSK10M_Rear Face_1cm_Ch23230_1RB_OS49

Communication System: LTE_FDD; Frequency: 782 MHz; Duty Cycle: 1:1
Medium: HSL750_0112 Medium parameters used: $f = 782 \text{ MHz}$; $\sigma = 0.918 \text{ S/m}$; $\epsilon_r = 42.794$; $\rho = 1000 \text{ kg/m}^3$
Ambient Temperature : 23.4°C; Liquid Temperature : 22.5°C

DASY5 Configuration:

- Probe: EX3DV4 - SN3985; ConvF(10.3, 10.3, 10.3) @ 782 MHz; Calibrated: 2023/07/10
- Sensor-Surface: 2mm (Mechanical Surface Detection)
- Electronics: DAE4 Sn755; Calibrated: 2023/03/23
- Phantom: SAM Right ; Type: QD000P40CD; Serial: TP:1502
- Measurement SW: DASY52, Version 52.8 (8); SEMCAD X Version 14.6.14 (7483)

-Area Scan (71x131x1): Interpolated grid: $dx=1.500 \text{ mm}$, $dy=1.500 \text{ mm}$
Maximum value of SAR (interpolated) = 0.222 W/kg

-Zoom Scan (5x5x7)/Cube 0: Measurement grid: $dx=8\text{mm}$, $dy=8\text{mm}$, $dz=5\text{mm}$
Reference Value = 11.98 V/m; Power Drift = 0.07 dB
Peak SAR (extrapolated) = 0.277 W/kg
SAR(1 g) = 0.167 W/kg; SAR(10 g) = 0.108 W/kg
Smallest distance from peaks to all points 3 dB below = 14.8 mm
Ratio of SAR at M2 to SAR at M1 = 62.1%
Maximum value of SAR (measured) = 0.215 W/kg

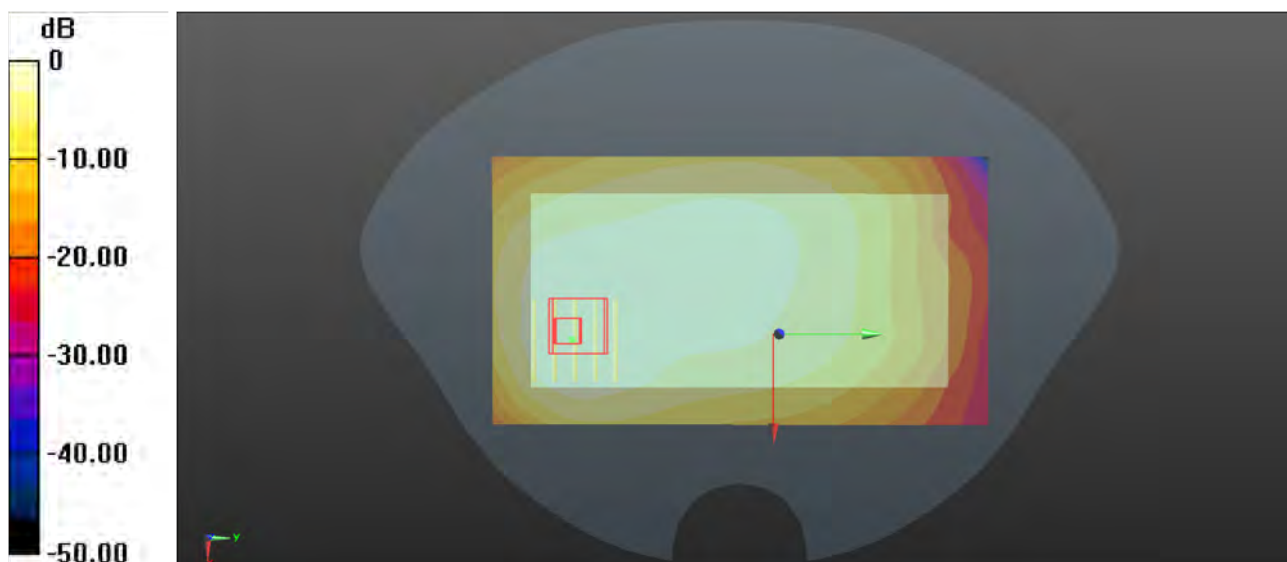

0 dB = 0.215 W/kg

P39 LTE 66_QPSK20M_Top Side_1cm_Ch132322_1RB_OS99

Communication System: LTE_FDD; Frequency: 1745 MHz; Duty Cycle: 1:1

Medium: HSL1750_0124 Medium parameters used: $f = 1745$ MHz; $\sigma = 1.364$ S/m; $\epsilon_r = 40.395$; $\rho = 1000$ kg/m³

Ambient Temperature : 23.3°C; Liquid Temperature : 22.4°C

DASY5 Configuration:

- Probe: EX3DV4 - SN3985; ConvF(8.53, 8.53, 8.53) @ 1745 MHz; Calibrated: 2023/07/10
- Sensor-Surface: 2mm (Mechanical Surface Detection)
- Electronics: DAE4 Sn755; Calibrated: 2023/03/23
- Phantom: SAM Right ; Type: QD000P40CD; Serial: TP:1502
- Measurement SW: DASY52, Version 52.8 (8); SEMCAD X Version 14.6.14 (7483)

-Area Scan (41x71x1): Interpolated grid: dx=1.500 mm, dy=1.500 mm

Maximum value of SAR (interpolated) = 0.867 W/kg

-Zoom Scan (5x5x7)/Cube 0: Measurement grid: dx=8mm, dy=8mm, dz=5mm

Reference Value = 23.07 V/m; Power Drift = 0.05 dB

Peak SAR (extrapolated) = 1.12 W/kg

SAR(1 g) = 0.670 W/kg; SAR(10 g) = 0.365 W/kg

Smallest distance from peaks to all points 3 dB below = 10.1 mm

Ratio of SAR at M2 to SAR at M1 = 60.8%

Maximum value of SAR (measured) = 0.918 W/kg

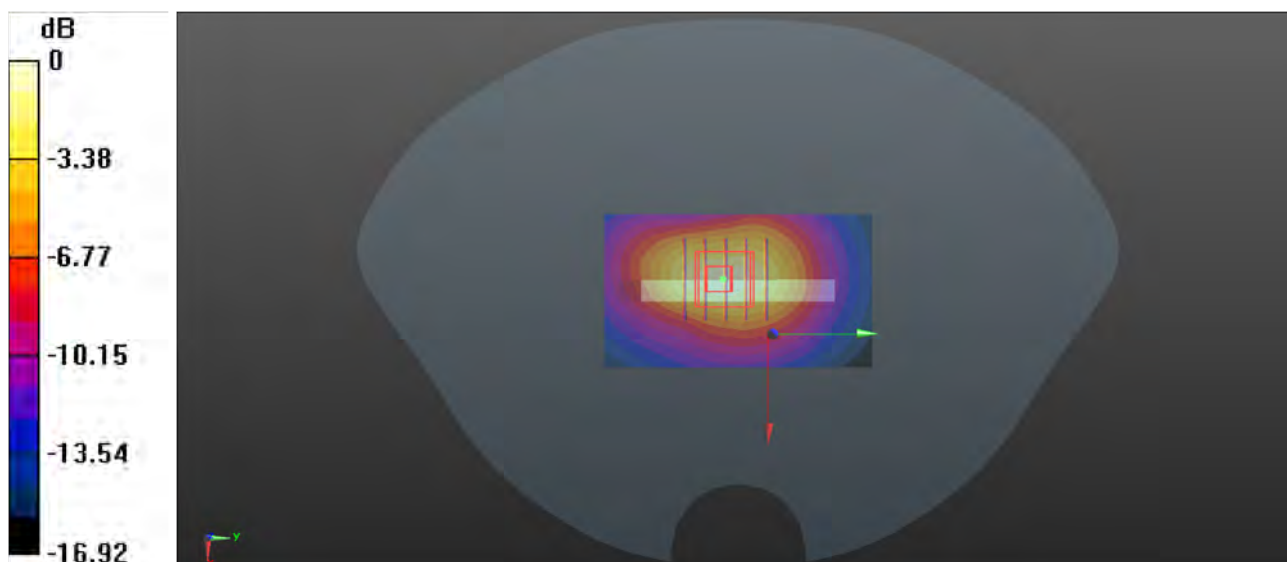

0 dB = 0.918 W/kg

P40 WLAN2.4G_802.11b_Rear Face_1cm_Ch6

Communication System: 802.11b; Frequency: 2437 MHz; Duty Cycle: 1:1.027

Medium: HSL2450_0113 Medium parameters used: $f = 2437$ MHz; $\sigma = 1.869$ S/m; $\epsilon_r = 39.644$; $\rho = 1000$ kg/m³

Ambient Temperature : 23.2°C; Liquid Temperature : 22.7°C

DASY5 Configuration:

- Probe: EX3DV4 - SN3985; ConvF(7.8, 7.8, 7.8) @ 2437 MHz; Calibrated: 2023/07/10
- Sensor-Surface: 2mm (Mechanical Surface Detection)
- Electronics: DAE4 Sn755; Calibrated: 2023/03/23
- Phantom: SAM Right ; Type: QD000P40CD; Serial: TP:1502
- Measurement SW: DASY52, Version 52.8 (8); SEMCAD X Version 14.6.14 (7483)

-Area Scan (81x81x1): Interpolated grid: dx=1.200 mm, dy=1.200 mm

Maximum value of SAR (interpolated) = 0.751 W/kg

-Zoom Scan (7x7x7)/Cube 0: Measurement grid: dx=5mm, dy=5mm, dz=5mm

Reference Value = 2.452 V/m; Power Drift = -0.05 dB

Peak SAR (extrapolated) = 1.08 W/kg

SAR(1 g) = 0.451 W/kg; SAR(10 g) = 0.196 W/kg

Smallest distance from peaks to all points 3 dB below = 7 mm

Ratio of SAR at M2 to SAR at M1 = 43.9%

Maximum value of SAR (measured) = 0.685 W/kg

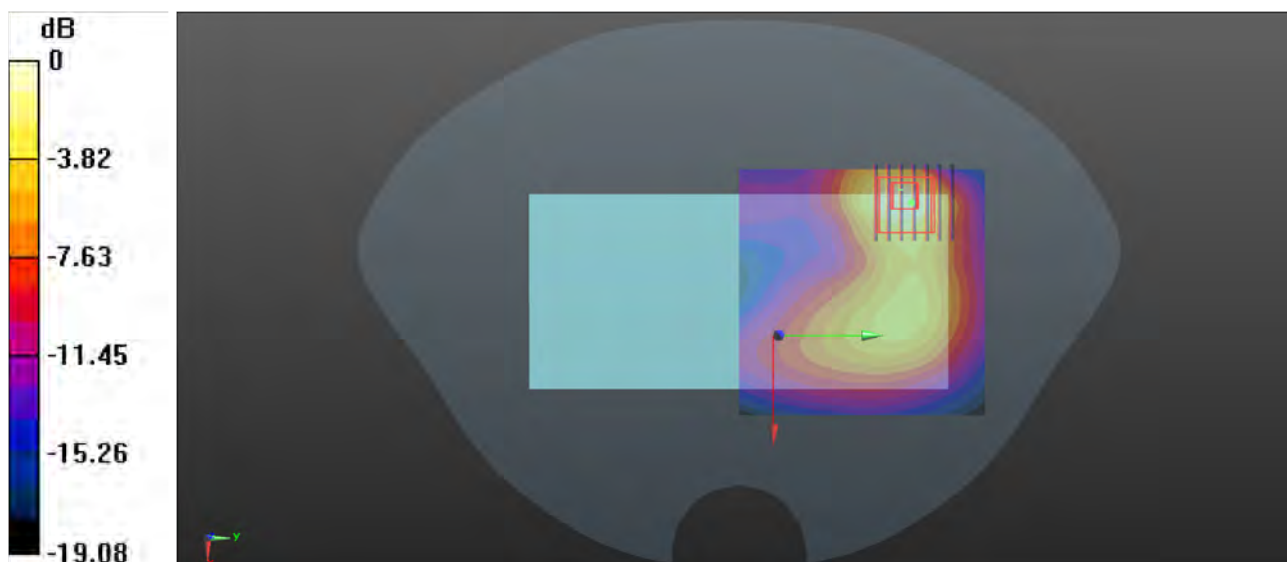

0 dB = 0.685 W/kg

P41 WLAN5G_802.11n-HT20_Rear Face_1cm_Ch36

Communication System: 802.11n_HT20; Frequency: 5180 MHz; Duty Cycle: 1:1.019
Medium: HSL5G_0125 Medium parameters used: $f = 5180$ MHz; $\sigma = 4.505$ S/m; $\epsilon_r = 35.396$; $\rho = 1000$ kg/m³
Ambient Temperature : 23.7°C; Liquid Temperature : 22.5°C

DASY5 Configuration:

- Probe: EX3DV4 - SN3985; ConvF(5.6, 5.6, 5.6) @ 5180 MHz; Calibrated: 2023/07/10
- Sensor-Surface: 2mm (Mechanical Surface Detection)
- Electronics: DAE4 Sn755; Calibrated: 2023/03/23
- Phantom: SAM Right ; Type: QD000P40CD; Serial: TP:1502
- Measurement SW: DASY52, Version 52.8 (8); SEMCAD X Version 14.6.14 (7483)

-Area Scan (101x101x1): Interpolated grid: dx=1.000 mm, dy=1.000 mm
Maximum value of SAR (interpolated) = 0.589 W/kg

-Zoom Scan (7x7x12)/Cube 0: Measurement grid: dx=4mm, dy=4mm, dz=2mm
Reference Value = 0.9980 V/m; Power Drift = 0.09 dB
Peak SAR (extrapolated) = 1.07 W/kg
SAR(1 g) = 0.292 W/kg; SAR(10 g) = 0.095 W/kg
Smallest distance from peaks to all points 3 dB below = 7.4 mm
Ratio of SAR at M2 to SAR at M1 = 56.3%
Maximum value of SAR (measured) = 0.571 W/kg



0 dB = 0.571 W/kg

P42 WLAN5G_802.11ac-VHT20_Rear Face_1cm_Ch149

Communication System: 802.11ac_VHT20; Frequency: 5745 MHz; Duty Cycle: 1:1.038
Medium: HSL5G_0126 Medium parameters used: $f = 5745$ MHz; $\sigma = 5.155$ S/m; $\epsilon_r = 34.384$; $\rho = 1000$ kg/m³
Ambient Temperature : 23.3°C; Liquid Temperature : 22.5°C

DASY5 Configuration:

- Probe: EX3DV4 - SN3985; ConvF(5.16, 5.16, 5.16) @ 5745 MHz; Calibrated: 2023/07/10
- Sensor-Surface: 2mm (Mechanical Surface Detection)
- Electronics: DAE4 Sn755; Calibrated: 2023/03/23
- Phantom: SAM Right ; Type: QD000P40CD; Serial: TP:1502
- Measurement SW: DASY52, Version 52.8 (8); SEMCAD X Version 14.6.14 (7483)

-Area Scan (101x91x1): Interpolated grid: dx=1.000 mm, dy=1.000 mm
Maximum value of SAR (interpolated) = 0.850 W/kg

-Zoom Scan (7x7x12)/Cube 0: Measurement grid: dx=4mm, dy=4mm, dz=2mm
Reference Value = 1.087 V/m; Power Drift = -0.02 dB
Peak SAR (extrapolated) = 1.70 W/kg
SAR(1 g) = 0.424 W/kg; SAR(10 g) = 0.137 W/kg
Smallest distance from peaks to all points 3 dB below = 8.2 mm
Ratio of SAR at M2 to SAR at M1 = 51.9%
Maximum value of SAR (measured) = 0.840 W/kg

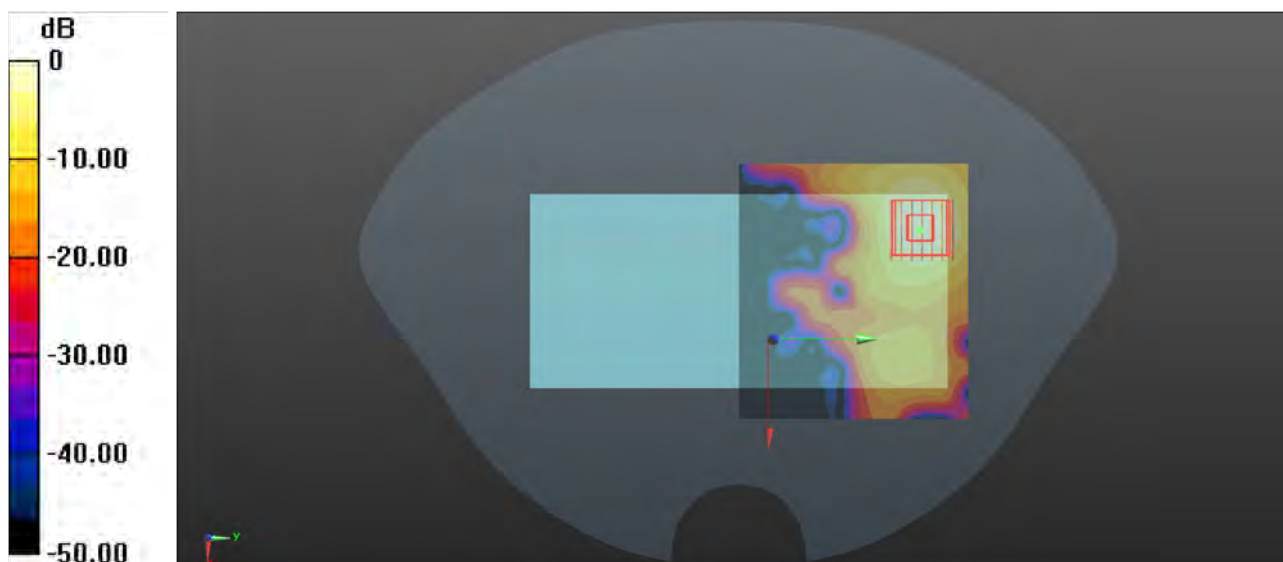

0 dB = 0.840 W/kg

P43 BT_GFSK_Rear Face_1cm_Ch0

Communication System: BT; Frequency: 2402 MHz; Duty Cycle: 1:1.295

Medium: HSL2450_0113 Medium parameters used: $f = 2402$ MHz; $\sigma = 1.843$ S/m; $\epsilon_r = 39.707$; $\rho = 1000$ kg/m³

Ambient Temperature : 23.2°C; Liquid Temperature : 22.7°C

DASY5 Configuration:

- Probe: EX3DV4 - SN3985; ConvF(7.8, 7.8, 7.8) @ 2402 MHz; Calibrated: 2023/07/10
- Sensor-Surface: 2mm (Mechanical Surface Detection)
- Electronics: DAE4 Sn755; Calibrated: 2023/03/23
- Phantom: SAM Right ; Type: QD000P40CD; Serial: TP:1502
- Measurement SW: DASY52, Version 52.8 (8); SEMCAD X Version 14.6.14 (7483)

-Area Scan (81x81x1): Interpolated grid: dx=1.200 mm, dy=1.200 mm

Maximum value of SAR (interpolated) = 0.131 W/kg

-Zoom Scan (7x7x7)/Cube 0: Measurement grid: dx=5mm, dy=5mm, dz=5mm

Reference Value = 0.9320 V/m; Power Drift = 0.09 dB

Peak SAR (extrapolated) = 0.174 W/kg

SAR(1 g) = 0.073 W/kg; SAR(10 g) = 0.031 W/kg

Smallest distance from peaks to all points 3 dB below = 8 mm

Ratio of SAR at M2 to SAR at M1 = 44.4%

Maximum value of SAR (measured) = 0.116 W/kg

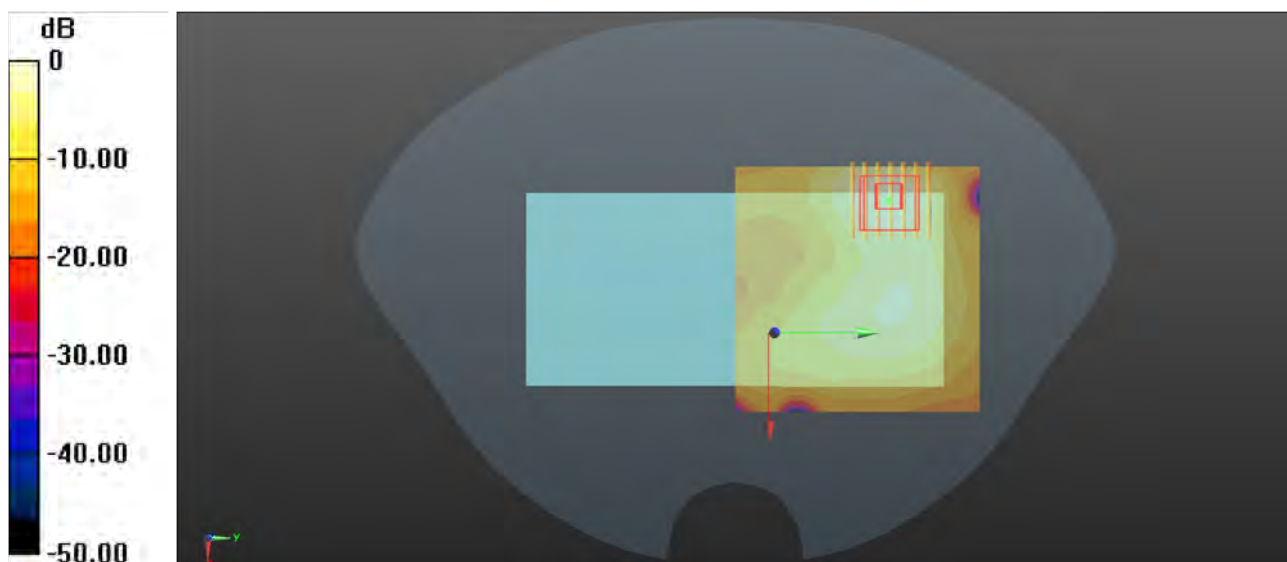

0 dB = 0.116 W/kg

P44 GSM1900_GPRS 4Tx Slot_Top Side_0cm_Ch810

Communication System: GPRS 4Tx Slot; Frequency: 1909.8 MHz; Duty Cycle: 1:2.08
Medium: HSL1950_0122 Medium parameters used: $f = 1910$ MHz; $\sigma = 1.45$ S/m; $\epsilon_r = 39.477$; $\rho = 1000$ kg/m³
Ambient Temperature : 23.5°C; Liquid Temperature : 22.6°C

DASY5 Configuration:

- Probe: EX3DV4 - SN3985; ConvF(8.26, 8.26, 8.26) @ 1909.8 MHz; Calibrated: 2023/07/10
- Sensor-Surface: 2mm (Mechanical Surface Detection)
- Electronics: DAE4 Sn755; Calibrated: 2023/03/23
- Phantom: SAM Right ; Type: QD000P40CD; Serial: TP:1502
- Measurement SW: DASY52, Version 52.8 (8); SEMCAD X Version 14.6.14 (7483)

-Area Scan (31x71x1): Interpolated grid: dx=1.500 mm, dy=1.500 mm
Maximum value of SAR (interpolated) = 11.1 W/kg

-Zoom Scan (5x5x7)/Cube 0: Measurement grid: dx=8mm, dy=8mm, dz=5mm
Reference Value = 41.43 V/m; Power Drift = 0.03 dB
Peak SAR (extrapolated) = 15.7 W/kg
SAR(1 g) = 5.23 W/kg; SAR(10 g) = 1.94 W/kg
Smallest distance from peaks to all points 3 dB below = 4.8 mm
Ratio of SAR at M2 to SAR at M1 = 31.7%
Maximum value of SAR (measured) = 11.4 W/kg

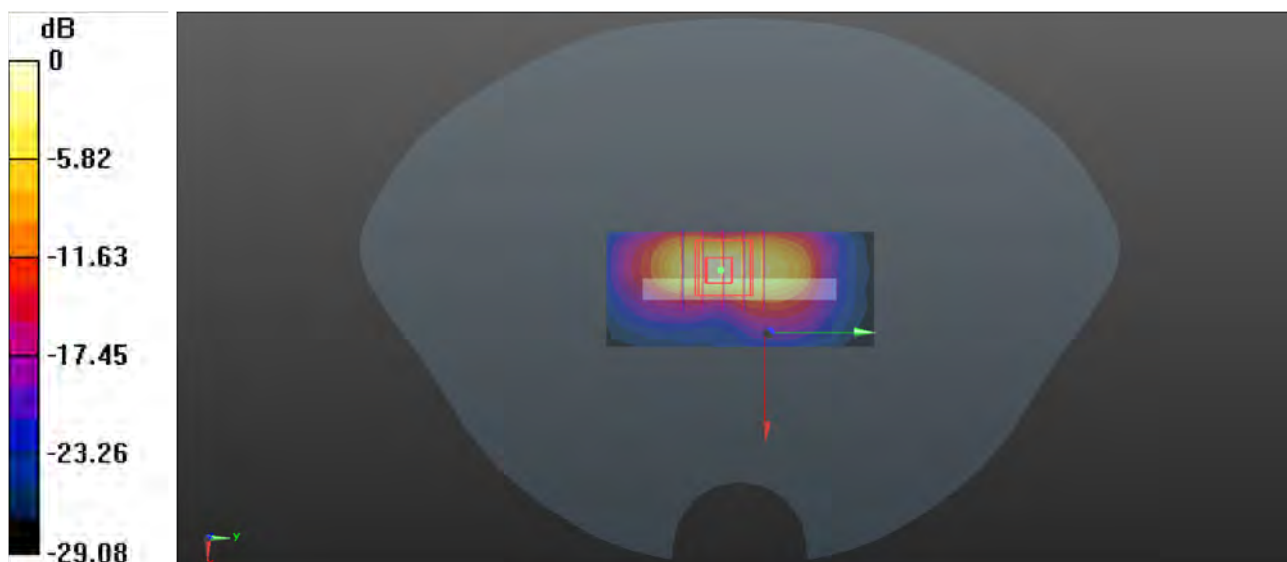

0 dB = 11.4 W/kg

P45 WCDMA II_RMC12.2K_Top Side_0cm_Ch9400

Communication System: WCDMA; Frequency: 1880 MHz; Duty Cycle: 1:1
Medium: HSL1950_0122 Medium parameters used: $f = 1880$ MHz; $\sigma = 1.43$ S/m; $\epsilon_r = 39.497$; $\rho = 1000$ kg/m³
Ambient Temperature : 23.5°C; Liquid Temperature : 22.6°C

DASY5 Configuration:

- Probe: EX3DV4 - SN3985; ConvF(8.26, 8.26, 8.26) @ 1880 MHz; Calibrated: 2023/07/10
- Sensor-Surface: 2mm (Mechanical Surface Detection)
- Electronics: DAE4 Sn755; Calibrated: 2023/03/23
- Phantom: SAM Right ; Type: QD000P40CD; Serial: TP:1502
- Measurement SW: DASY52, Version 52.8 (8); SEMCAD X Version 14.6.14 (7483)

-Area Scan (41x71x1): Interpolated grid: dx=1.500 mm, dy=1.500 mm
Maximum value of SAR (interpolated) = 7.67 W/kg

-Zoom Scan (5x5x7)/Cube 0: Measurement grid: dx=8mm, dy=8mm, dz=5mm
Reference Value = 60.11 V/m; Power Drift = 0.08 dB
Peak SAR (extrapolated) = 13.9 W/kg
SAR(1 g) = 5.53 W/kg; SAR(10 g) = 2.23 W/kg
Smallest distance from peaks to all points 3 dB below = 4.8 mm
Ratio of SAR at M2 to SAR at M1 = 39.7%
Maximum value of SAR (measured) = 9.53 W/kg

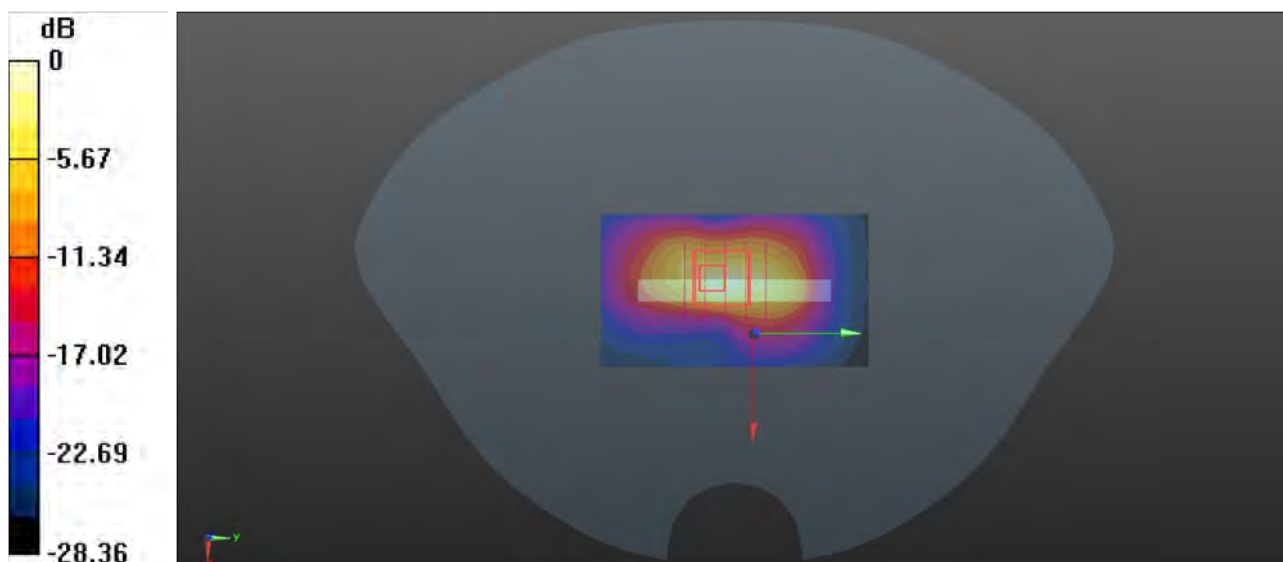

0 dB = 9.53 W/kg

P46 LTE 2_QPSK20M_Top Side_0cm_Ch18700_50RB_OS25

Communication System: LTE_FDD; Frequency: 1860 MHz; Duty Cycle: 1:1

Medium: HSL1950_0123 Medium parameters used: $f = 1860$ MHz; $\sigma = 1.41$ S/m; $\epsilon_r = 39.509$; $\rho = 1000$ kg/m³

Ambient Temperature : 23.1°C; Liquid Temperature : 22.3°C

DASY5 Configuration:

- Probe: EX3DV4 - SN3985; ConvF(8.26, 8.26, 8.26) @ 1860 MHz; Calibrated: 2023/07/10
- Sensor-Surface: 2mm (Mechanical Surface Detection)
- Electronics: DAE4 Sn755; Calibrated: 2023/03/23
- Phantom: SAM Right ; Type: QD000P40CD; Serial: TP:1502
- Measurement SW: DASY52, Version 52.8 (8); SEMCAD X Version 14.6.14 (7483)

-Area Scan (41x71x1): Interpolated grid: dx=1.500 mm, dy=1.500 mm

Maximum value of SAR (interpolated) = 7.33 W/kg

-Zoom Scan (5x5x7)/Cube 0: Measurement grid: dx=8mm, dy=8mm, dz=5mm

Reference Value = 60.22 V/m; Power Drift = 0.06 dB

Peak SAR (extrapolated) = 16.0 W/kg

SAR(1 g) = 6.06 W/kg; SAR(10 g) = 2.43 W/kg

Smallest distance from peaks to all points 3 dB below = 4.8 mm

Ratio of SAR at M2 to SAR at M1 = 35%

Maximum value of SAR (measured) = 12.5 W/kg

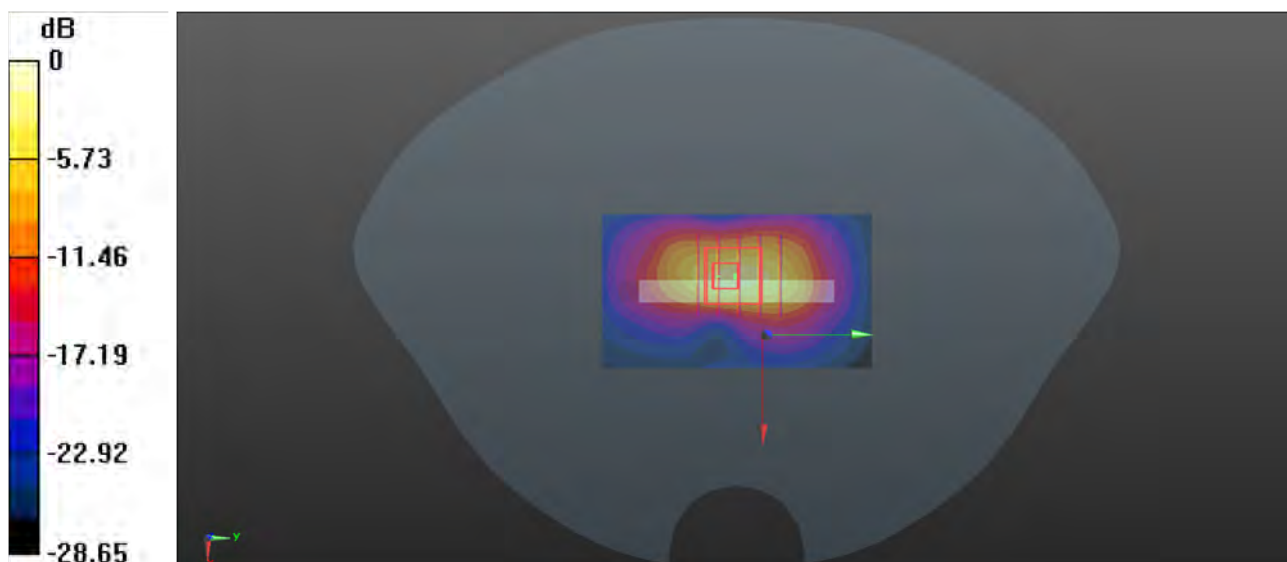

0 dB = 12.5 W/kg

P47 LTE 66_QPSK20M_Top Side_0cm_Ch132572_50RB_OS50

Communication System: LTE_FDD; Frequency: 1770 MHz; Duty Cycle: 1:1

Medium: HSL1750_0124 Medium parameters used: $f = 1770$ MHz; $\sigma = 1.379$ S/m; $\epsilon_r = 40.344$; $\rho = 1000$ kg/m³

Ambient Temperature : 23.3°C; Liquid Temperature : 22.4°C

DASY5 Configuration:

- Probe: EX3DV4 - SN3985; ConvF(8.53, 8.53, 8.53) @ 1770 MHz; Calibrated: 2023/07/10
- Sensor-Surface: 2mm (Mechanical Surface Detection)
- Electronics: DAE4 Sn755; Calibrated: 2023/03/23
- Phantom: SAM Right ; Type: QD000P40CD; Serial: TP:1502
- Measurement SW: DASY52, Version 52.8 (8); SEMCAD X Version 14.6.14 (7483)

-Area Scan (41x71x1): Interpolated grid: dx=1.500 mm, dy=1.500 mm

Maximum value of SAR (interpolated) = 6.32 W/kg

-Zoom Scan (5x5x7)/Cube 0: Measurement grid: dx=8mm, dy=8mm, dz=5mm

Reference Value = 49.71 V/m; Power Drift = 0.04 dB

Peak SAR (extrapolated) = 11.8 W/kg

SAR(1 g) = 4.8 W/kg; SAR(10 g) = 2.03 W/kg

Smallest distance from peaks to all points 3 dB below = 4.8 mm

Ratio of SAR at M2 to SAR at M1 = 38.2%

Maximum value of SAR (measured) = 9.33 W/kg

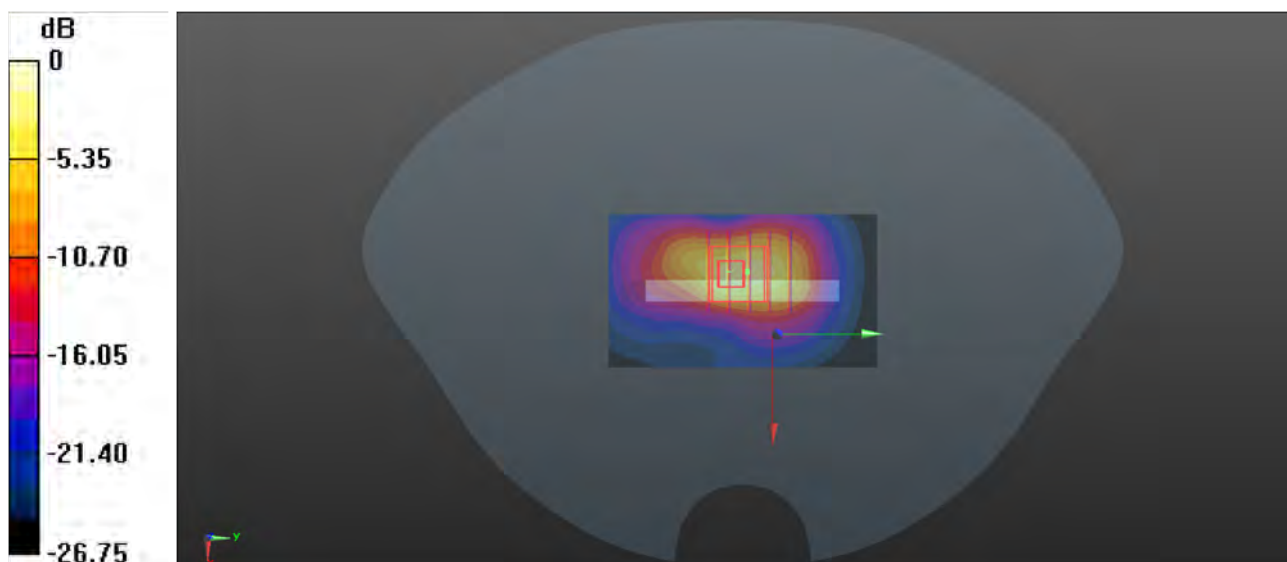

0 dB = 9.33 W/kg

P48 WLAN5G_802.11n-HT20_Rear Face_0cm_Ch36

Communication System: 802.11n_HT20; Frequency: 5180 MHz; Duty Cycle: 1:1.019
Medium: HSL5G_0125 Medium parameters used: $f = 5180$ MHz; $\sigma = 4.505$ S/m; $\epsilon_r = 35.396$; $\rho = 1000$ kg/m³
Ambient Temperature : 23.7°C; Liquid Temperature : 22.5°C

DASY5 Configuration:

- Probe: EX3DV4 - SN3985; ConvF(5.6, 5.6, 5.6) @ 5180 MHz; Calibrated: 2023/07/10
- Sensor-Surface: 2mm (Mechanical Surface Detection)
- Electronics: DAE4 Sn755; Calibrated: 2023/03/23
- Phantom: SAM Right ; Type: QD000P40CD; Serial: TP:1502
- Measurement SW: DASY52, Version 52.8 (8); SEMCAD X Version 14.6.14 (7483)

-Area Scan (101x91x1): Interpolated grid: dx=1.000 mm, dy=1.000 mm
Maximum value of SAR (interpolated) = 7.61 W/kg

-Zoom Scan (7x7x12)/Cube 0: Measurement grid: dx=4mm, dy=4mm, dz=2mm
Reference Value = 0.6820 V/m; Power Drift = 0.01 dB
Peak SAR (extrapolated) = 26.1 W/kg
SAR(1 g) = 4.68 W/kg; SAR(10 g) = 0.973 W/kg
Smallest distance from peaks to all points 3 dB below = 4.3 mm
Ratio of SAR at M2 to SAR at M1 = 53.2%
Maximum value of SAR (measured) = 11.9 W/kg

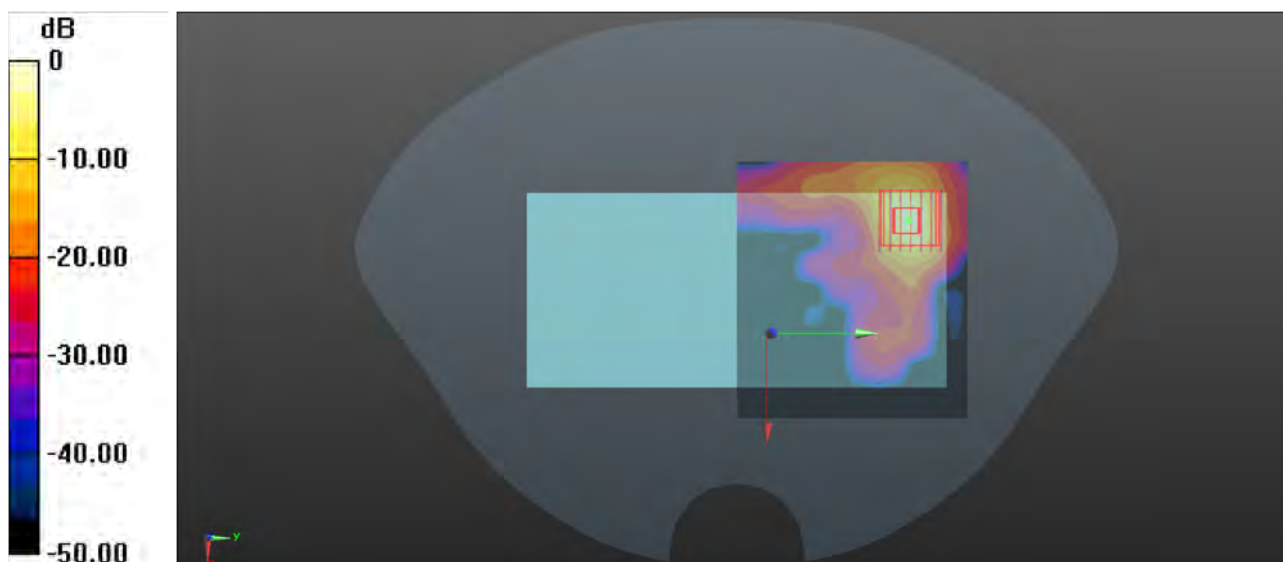

0 dB = 11.9 W/kg

P49 WLAN5G_802.11a_Top Side_0cm_Ch60

Communication System: 802.11a; Frequency: 5300 MHz; Duty Cycle: 1:1.018

Medium: HSL5G_0125 Medium parameters used: $f = 5300$ MHz; $\sigma = 4.664$ S/m; $\epsilon_r = 35.102$; $\rho = 1000$ kg/m³

Ambient Temperature : 23.7°C; Liquid Temperature : 22.5°C

DASY5 Configuration:

- Probe: EX3DV4 - SN3985; ConvF(5.6, 5.6, 5.6) @ 5300 MHz; Calibrated: 2023/07/10
- Sensor-Surface: 2mm (Mechanical Surface Detection)
- Electronics: DAE4 Sn755; Calibrated: 2023/03/23
- Phantom: SAM Right ; Type: QD000P40CD; Serial: TP:1502
- Measurement SW: DASY52, Version 52.8 (8); SEMCAD X Version 14.6.14 (7483)

-Area Scan (41x101x1): Interpolated grid: dx=1.000 mm, dy=1.000 mm

Maximum value of SAR (interpolated) = 12.5 W/kg

-Zoom Scan (7x7x12)/Cube 0: Measurement grid: dx=4mm, dy=4mm, dz=2mm

Reference Value = 15.56 V/m; Power Drift = 0.02 dB

Peak SAR (extrapolated) = 39.7 W/kg

SAR(1 g) = 7.07 W/kg; SAR(10 g) = 1.51 W/kg

Smallest distance from peaks to all points 3 dB below = 4 mm

Ratio of SAR at M2 to SAR at M1 = 51.3%

Maximum value of SAR (measured) = 17.6 W/kg

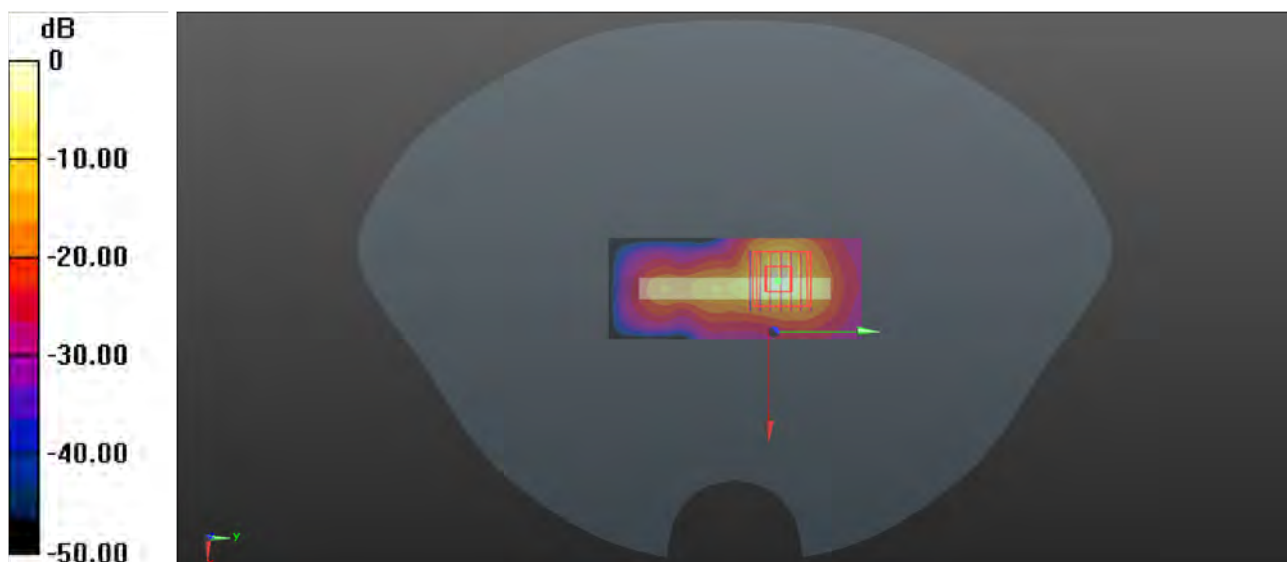

0 dB = 17.6 W/kg

P50 WLAN5G_802.11a_Top Side_0cm_Ch140

Communication System: 802.11a; Frequency: 5700 MHz; Duty Cycle: 1:1.018

Medium: HSL5G_0126 Medium parameters used: $f = 5700$ MHz; $\sigma = 5.096$ S/m; $\epsilon_r = 35.504$; $\rho = 1000$ kg/m³

Ambient Temperature : 23.3°C; Liquid Temperature : 22.5°C

DASY5 Configuration:

- Probe: EX3DV4 - SN3985; ConvF(5.08, 5.08, 5.08) @ 5700 MHz; Calibrated: 2023/07/10
- Sensor-Surface: 2mm (Mechanical Surface Detection)
- Electronics: DAE4 Sn755; Calibrated: 2023/03/23
- Phantom: SAM Right ; Type: QD000P40CD; Serial: TP:1502
- Measurement SW: DASY52, Version 52.8 (8); SEMCAD X Version 14.6.14 (7483)

-Area Scan (61x101x1): Interpolated grid: dx=1.000 mm, dy=1.000 mm

Maximum value of SAR (interpolated) = 2.93 W/kg

-Zoom Scan (7x7x12)/Cube 0: Measurement grid: dx=4mm, dy=4mm, dz=2mm

Reference Value = 4.711 V/m; Power Drift = 0.01 dB

Peak SAR (extrapolated) = 13.3 W/kg

SAR(1 g) = 1.96 W/kg; SAR(10 g) = 0.401 W/kg

Smallest distance from peaks to all points 3 dB below = 4 mm

Ratio of SAR at M2 to SAR at M1 = 51.2%

Maximum value of SAR (measured) = 4.93 W/kg

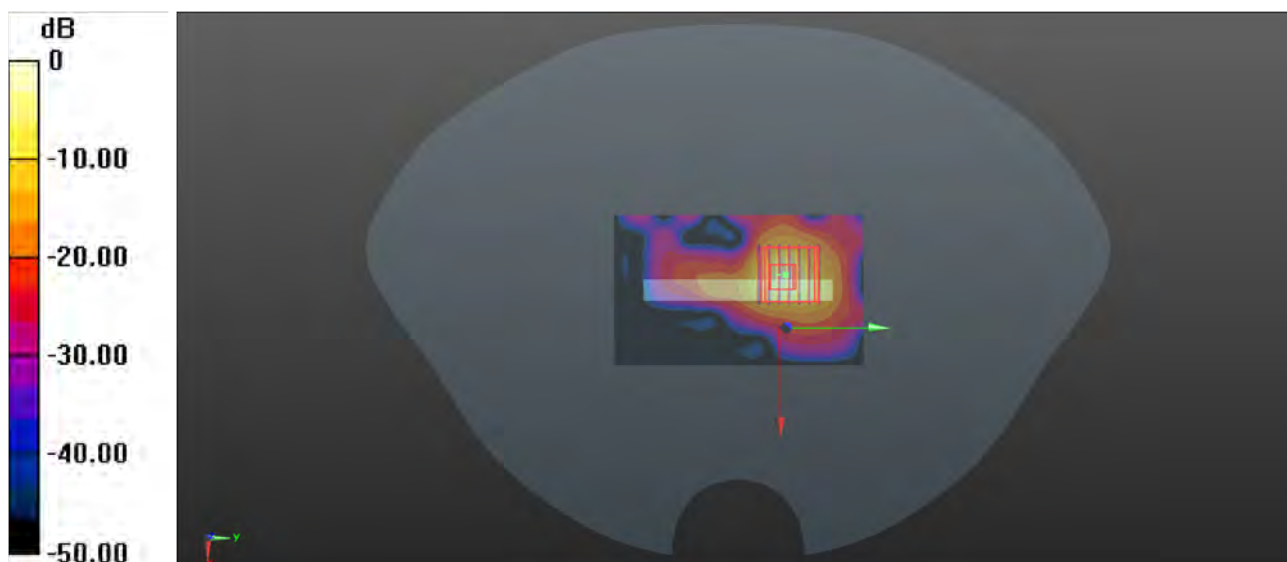

0 dB = 4.93 W/kg