



TEST REPORT

No.B23N00001-HAC T-coil

For

HMD Global Oy

Smartphone

Model Name: TA-1486

With

Hardware Version: V1.00

Software Version: 00WW_1_010_C01

FCC ID: 2AJOTTA-1486

Results Summary: T Rating = T3

Issued Date: 2023-03-06

Designation Number: CN1210

Note:

The test results in this test report relate only to the devices specified in this report. This report shall not be reproduced except in full without the written approval of SAICT.

Test Laboratory:

SAICT, Shenzhen Academy of Information and Communications Technology

Building G, Shenzhen International Innovation Center, No.1006 Shennan Road, Futian District, Shenzhen, Guangdong, P. R. China 518000.

Tel:+86(0)755-33322000, Fax:+86(0)755-33322001

Email: yewu@saict.ac.cn. www.saict.ac.cn



REPORT HISTORY

Report Number	Revision	Description	Issue Date
B23N00001-HAC T-coil	Rev.0	1st edition	2023-03-06



CONTENTS

1. SUMMARY OF TEST REPORT.....	5
1.1. TEST ITEMS	5
1.2. TEST STANDARDS	5
1.3. TEST RESULT	5
1.4. TESTING LOCATION	5
1.5. PROJECT DATA	5
1.6. SIGNATURE	5
2. CLIENT INFORMATION	6
2.1. APPLICANT INFORMATION	6
2.2. MANUFACTURER INFORMATION	6
3. EQUIPMENT UNDER TEST (EUT) AND ANCILLARY EQUIPMENT (AE).....	7
3.1. ABOUT EUT	7
3.2. INTERNAL IDENTIFICATION OF EUT USED DURING THE TEST.....	7
3.3. INTERNAL IDENTIFICATION OF AE USED DURING THE TEST	7
3.4. AIR INTERFACES AND OPERATING MODES	8
4. REFERENCE DOCUMENTS	9
5. OPERATIONAL CONDITIONS DURING TEST	10
5.1. HAC MEASUREMENT SET-UP	10
5.2. AM1D PROBE	12
5.3. AMCC.....	12
5.4. AMMI.....	12
5.5. TEST ARCH PHANTOM & PHONE POSITIONER	13
5.6. ROBOTIC SYSTEM SPECIFICATIONS	14
5.7. T-COIL MEASUREMENT POINTS AND REFERENCE PLANE	14
6. T-COIL TEST PROCEDURES	16
7. T-COIL PERFORMANCE REQUIREMENTS	17
7.1. T-COIL COUPLING FIELD INTENSITY.....	17
7.2. FREQUENCY RESPONSE	17
7.3. SIGNAL QUALITY.....	18
8. T-COIL TESTING FOR CMRS VOICE	19
8.1. GSM TESTS RESULTS	19
8.2. WCDMA TESTS RESULTS.....	20
9. T-COIL TESTING FOR VOLTE.....	21
9.1. TEST SYSTEM SETUP FOR VOLTE OVER IMS T-COIL TESTING	21
9.2. CODEC CONFIGURATION	22
9.3. RADIO CONFIGURATION	23
9.4. VOLTE TESTS RESULTS	24



10. T-COIL TESTING FOR VONR.....	25
10.1. TEST DATA SUMMARY	25
11. T-COIL TESTING FOR VOWIFI.....	28
11.1. TEST SYSTEM SETUP FOR VOWIFI OVER IMS T-COIL TESTING	28
11.2. CODEC CONFIGURATION	29
11.3. RADIO CONFIGURATION	30
11.4. VOWIFI TESTS RESULTS	30
12. T-COIL TESTING FOR OTT VOIP CALLING	31
12.1. TEST SYSTEM SETUP FOR OTT VoIP T-COIL TESTING	31
12.2. TEST DATA SUMMARY	33
12.3. 5G FR1 OTT EVALUATION	35
13. MEASUREMENT UNCERTAINTY	36
14. MAIN TEST INSTRUMENTS.....	37
ANNEX A: TEST PLOTS	38
ANNEX B: FREQUENCY RESPONSE CURVES	210
ANNEX C: PROBE CALIBRATION CERTIFICATE.....	235
ANNEX D: DAE CALIBRATION CERTIFICATE.....	238



1. Summary of Test Report

1.1. Test Items

Description:	Smartphone
Model Name:	TA-1486
Applicant's Name:	HMD Global Oy
Manufacturer's Name:	HMD Global Oy

1.2. Test Standards

ANSI C63.19-2011

1.3. Test Result

Pass

1.4. Testing Location

Address: Building G, Shenzhen International Innovation Center, No.1006 Shennan Road, Futian District, Shenzhen, Guangdong, P. R. China

1.5. Project Data

Testing Start Date: 2023-01-20

Testing End Date: 2023-02-12

1.6. Signature

Li Yongfu
(Prepared this test report)

Liu Jian
(Reviewed this test report)

Cao Junfei
(Approved this test report)



2. Client Information

2.1. Applicant Information

Company Name:	HMD Global Oy
Address:	Bertel Jungin aukio 9, 02600 Espoo, Finland
City:	Espoo
Country:	Finland
Telephone:	+491735287964

2.2. Manufacturer Information

Company Name:	HMD Global Oy
Address:	Bertel Jungin aukio 9, 02600 Espoo, Finland
City:	Espoo
Country:	Finland
Telephone:	+491735287964



3. Equipment Under Test (EUT) and Ancillary Equipment (AE)

3.1. About EUT

Description:	Smartphone
Mode Name:	TA-1486
Condition of EUT as received:	No obvious damage in appearance
Frequency Bands:	GSM 850/1900, WCDMA Band 2/4/5, LTE Band 2/4/5/7/12/13/17/25/26/38/41/42/43/48/66/71, NR n2/n5/n7/n25/n38/n41/n48/n66/n71/n77/n78, Bluetooth, WLAN 2.4GHz, WLAN 5GHz

3.2. Internal Identification of EUT used during the test

EUT ID*	IMEI	HW Version	SW Version	Receipt Date
UT02aa	352739200025713	V1.00	00WW_1_010_C01	2023-01-04

*EUT ID: is used to identify the test sample in the lab internally.

Note: It is performed to test HAC with the UT02aa.

3.3. Internal Identification of AE used during the test

AE ID*	Description	Model	Manufacturer
AE1	Battery	LPN388463	Highpower
AE2	Headset	NLD-EM301K-17SF	HUIZHOU NEW LEADER INDUSTRY CO., LTD

*AE ID: is used to identify the test sample in the lab internally.



3.4. Air Interfaces and Operating Modes

Air-interface	Band(MHz)	Type	C63.19 / tested	Simultaneous Transmissions	Name of Voice Service	Power Reduction
GSM	850/1900	VO	Yes	BT,WLAN	CMRS Voice	No
EDGE	850/1900	DT	Yes	BT,WLAN	Google Duo	No
WCDMA	B2/B4/B5	VO	Yes	BT,WLAN	CMRS Voice	No
	HSPA	VD	Yes	BT,WLAN	Google Duo	No
LTE (FDD)	2/4/5/7/12/13/ 17/25/26/66/71	VD	Yes	NR,BT,WLAN	VoLTE, Google Duo	No
LTE (TDD)	38/41/42/43/48	VD	Yes	NR,BT,WLAN	VoLTE, Google Duo	No
NR (FDD)	n2/n5/n7/n25/n66/n71	VD	Yes	LTE,BT,WLAN	Google Duo	No
NR (TDD)	n38/n41/n48/n77/n78	VD	Yes	LTE,BT,WLAN	Google Duo	No
WLAN	2.4GHz	VD	Yes	WWAN	VoWIFI Google Duo	No
WLAN	5GHz	VD	Yes	WWAN	VoWIFI Google Duo	No
Bluetooth	2.4GHz	DT	No	WWAN	NA	No

VO: Voice Only

VD: CMRS and IP Voice Service over Digital Transport

DT: Digital Transport only (no voice)

* HAC Rating was not based on concurrent voice and data modes; Non-current mode was found to represent worst case rating for both M and T rating



4. Reference Documents

The following document listed in this section is referred for testing.

Reference	Title	Version
ANSI C63.19-2011	American National Standard for Methods of Measurement of Compatibility between Wireless Communication Devices and Hearing Aids	2011
KDB 285076 D01	Equipment Authorization Guidance for Hearing Aid Compatibility	v06r02
KDB 285076 D02	Guidance for performing T-Coil tests for air interfaces supporting voice over IP (e.g., LTE and WiFi) to support CMRS based telephone services	v04
KDB 285076 D03	Hearing Aid Compatibility Frequently Asked Questions	v01r06

5. Operational Conditions during Test

5.1. HAC Measurement Set-up

These measurements are performed using the DASY5 NEO automated dosimetric assessment system. It is made by Schmid & Partner Engineering AG (SPEAG) in Zurich, Switzerland. It consists of high precision robotics system (Stäubli), robot controller, Intel Core2 computer, near-field probe, probe alignment sensor. The robot is a six-axis industrial robot performing precise movements. A cell controller system contains the power supply, robot controller, teach pendant (Joystick), and remote control, is used to drive the robot motors. The PC consists of the HP Intel Core2 1.86 GHz computer with Windows XP system and HAC Measurement Software DASY5 NEO, A/D interface card, monitor, mouse, and keyboard. The Stäubli Robot is connected to the cell controller to allow software manipulation of the robot. A data acquisition electronic (DAE) circuit performs the signal amplification; signal multiplexing, AD-conversion, offset measurements, mechanical surface detection, collision detection, etc. is connected to the Electro-optical coupler (EOC). The EOC performs the conversion from the optical into digital electric signal of the DAE and transfers data to the PC plug-in card.

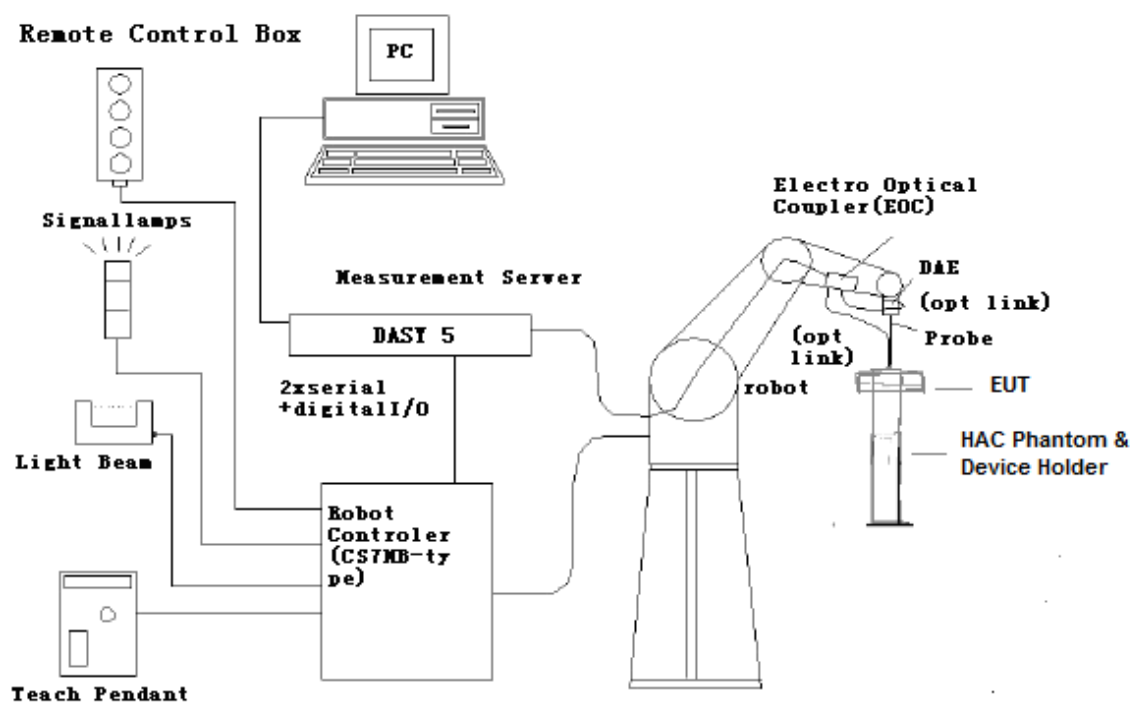

Figure 5.1 HAC Test Measurement Set-up

The DAE4 consists of a highly sensitive electrometer-grade preamplifier with auto-zeroing, a channel and gain-switching multiplexer, a fast 16 bit AD-converter and a command decoder and control logic unit. Transmission to the PC-card is accomplished through an optical downlink for data and status information and an optical uplink for commands and clock lines. The mechanical probe mounting device includes two different sensor systems for frontal and sidewise probe contacts. They are also used for mechanical surface detection and probe collision detection. The robot uses its own controller with a built in VME-bus computer.

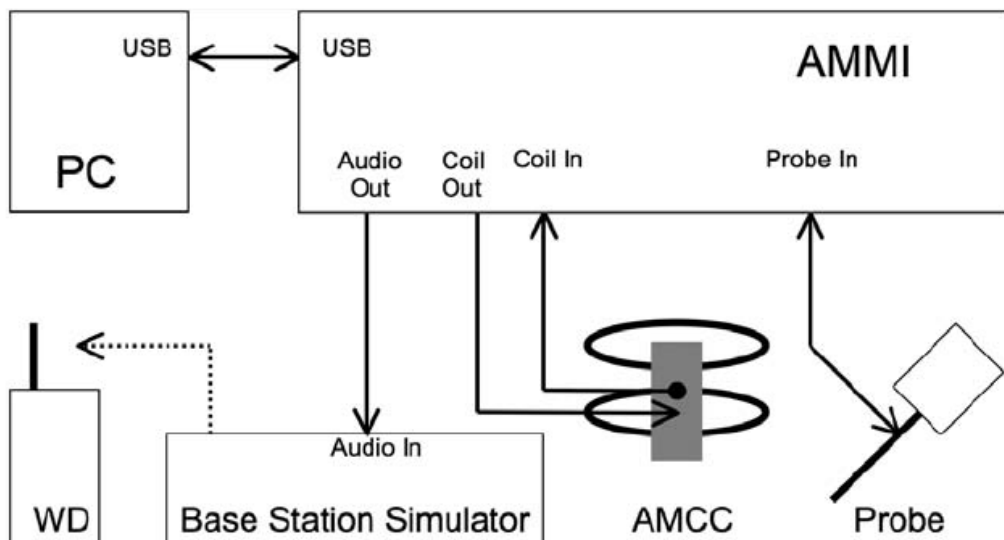

Figure 5.2 T-Coil setup with HAC Test Arch and AMCC

5.2. AM1D probe

The AM1D probe is an active probe with a single sensor. It is fully RF-shielded and has a rounded tip 6mm in diameter incorporating a pickup coil with its center offset 3mm from the tip and the sides. The symmetric signal preamplifier in the probe is fed via the shielded symmetric output cable from the AMMI with a 48V "phantom" voltage supply. The 7-pin connector on the back in the axis of the probe does not carry any signals. It is mounted to the DAE for the correct orientation of the sensor. If the probe axis is tilted 54.7 degree from the vertical, the sensor is approximately vertical when the signal connector is at the underside of the probe (cable hanging downwards).

Specification:

Frequency range	0.1~20kHz (RF sensitivity < -100dB, fully RF shielded)
Sensitivity	< -50dB A/m @ 1kHz
Pre-amplifier	40dB, symmetric
Dimensions	Tip diameter/length: 6/290mm, sensor according to ANSI-C63.19

5.3. AMCC

The Audio Magnetic Calibration coil is a Helmholtz Coil designed for calibration of the AM1D probe. The two horizontal coils generate a homogeneous magnetic field in the z direction. The DC input resistance is adjusted by a series resistor to approximately 50Ohm, and a shunt resistor of 10Ohm permits monitoring the current with a scale of 1:10

Port description:

Signal	Connector	Resistance
Coil In	BNC	Typically 50Ohm
Coil Monitor	BNO	10Ohm±1% (100mV corresponding to 1 A/m)

Specification:

Dimensions	370 x 370 x 196 mm, according to ANSI-C63.19
-------------------	--

5.4. AMMI



Figure 5.3 AMMI front panel

The Audio Magnetic Measuring Instrument (AMMI) is a desktop 19-inch unit containing a sampling unit, a waveform generator for test and calibration signals, and a USB interface.

Specification:

Sampling rate	48 kHz / 24 bit
Dynamic range	85 dB
Test signal generation	User selectable and predefined (vis PC)
Calibration	Auto-calibration / full system calibration using AMCC with monitor output
Dimensions	482 x 65 x 270 mm

5.5. Test Arch Phantom & Phone Positioner

The Test Arch phantom should be positioned horizontally on a stable surface. Reference markings on the Phantom allow the complete setup of all predefined phantom positions and measurement grids by manually teaching three points in the robot. It enables easy and well defined positioning of the phone and validation dipoles as well as simple teaching of the robot (Dimensions: 370 x 370 x 370 mm).

The Phone Positioner supports accurate and reliable positioning of any phone with effect on near field $\leq \pm 0.5$ dB.

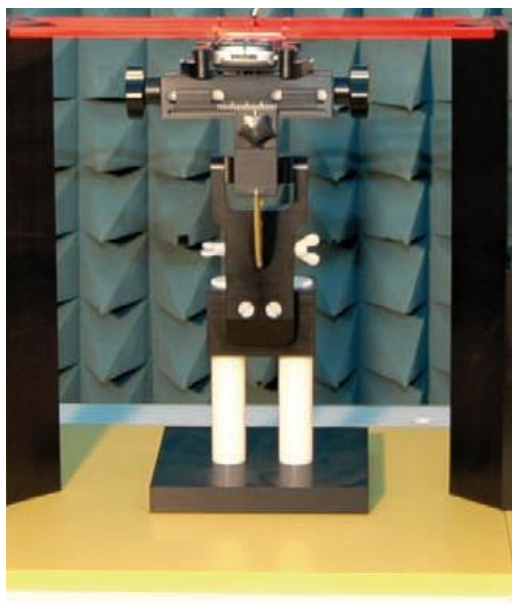

Figure 5.4 HAC Phantom & Device Holder



5.6. Robotic System Specifications

Specifications

Positioner: Stäubli Unimation Corp. Robot Model: RX160L

Repeatability: ± 0.02 mm

No. of Axis: 6

Data Acquisition Electronic (DAE) System

Cell Controller

Processor: Intel Core2

Clock Speed: 1.86 GHz

Operating System: Windows XP

Data Converter

Features: Signal Amplifier, multiplexer, A/D converter, and control logic

Software: DASY5 software

Connecting Lines: Optical downlink for data and status info.

Optical uplink for commands and clock

5.7. T-Coil measurement points and reference plane

Figure 6.5 illustrates the standard probe orientations. Position 1 is the perpendicular orientation of the probe coil; orientation 2 is the transverse orientations. The space between the measurement positions is not fixed. It is recommended that a scan of the WD be done for each probe coil orientation and that the maximum level recorded be used as the reading for that orientation of the probe coil.

- 1) The reference plane is the planar area that contains the highest point in the area of the phone that normally rests against the user's ear. It is parallel to the centerline of the receiver area of the phone and is defined by the points of the receiver-end of the WD handset, which, in normal handset use, rest against the ear.
- 2) The measurement plane is parallel to, and 10 mm in front of, the reference plane.
- 3) The reference axis is normal to the reference plane and passes through the center of the receiver speaker section (or the center of the hole array); or may be centered on a secondary inductive source. The actual location of the measurement point shall be noted in the test report as the measurement reference point.
- 4) The measurement points may be located where the axial and radial field intensity measurements are optimum with regard to the requirements. However, the measurement points should be near the acoustic output of the WD and shall be located in the same half of the phone as the WD receiver. In a WD handset with a centered receiver and a circularly symmetrical magnetic field, the measurement axis and the reference axis would coincide.
- 5) The relative spacing of each measurement orientation is not fixed. The axial and two radial orientations should be chosen to select the optimal position.
- 6) The measurement point for the axial position is located 10 mm from the reference plane on the measurement axis. The actual location of the measurement point shall be noted in test reports and designated as the measurement reference point.

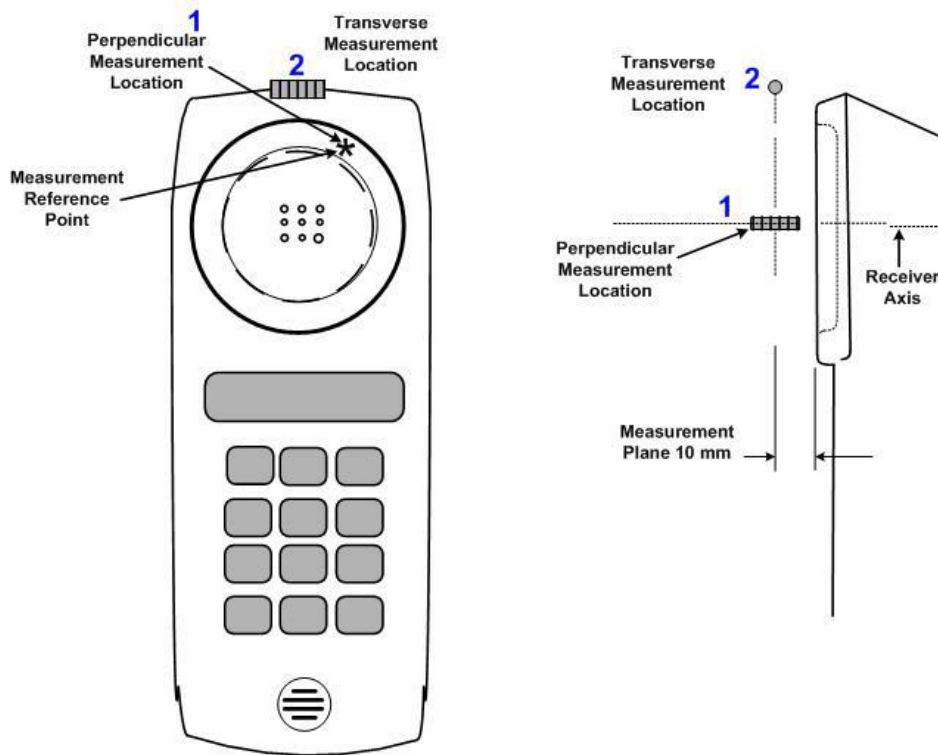

Figure 5.5 Axis and planes for WD audio frequency magnetic field measurements

6. T-Coil Test Procedures

The following illustrate a typical test scan over a wireless communications device:

- 1) Geometry and signal check: system probe alignment, proper operation of the field probe, probe measurement system, other instrumentation, and the positioning system was confirmed. A surface calibration was performed before each setup change to ensure repeatable spacing and proper maintenance of the measurement plane using the test Arch.
- 2) Set the reference drive level of signal voice defined in C63.19 per 7.4.2.1.
- 3) The ambient and test system background noise (dB A/m) was measured as well as ABM2 over the full measurement. The maximum noise level must be at least 10dB below the limit.
- 4) The DUT was positioned in its intended test position, acoustic output point of the device perpendicular to the field probe.
- 5) The DUT operation for maximum rated RF output power was configured and connected by using of coaxial cable connection to the base station simulator at the test channel and other normal operating parameters as intended for the test. The battery was ensured to be fully charged before each test. The center sub-grid was centered over the center of the acoustic output (also audio band magnetic output, if applicable). The DUT audio output was positioned tangent (as physically possible) to the measurement plane.
- 6) The DUT's RF emission field was eliminated from T-coil results by using a well RF-shielding of the probe, AM1D, and by using of coaxial cable connection to a Base Station Simulator. One test channel was pre-measurement to avoid this possibility.
- 7) Determined the optimal measurement locations for the DUT by following the three steps, coarse resolution scan, fine resolution scans, and point measurement, as described in C63.19 per 7.4.4.2. At each measurement locations, samples in the measurement window duration were evaluated to get ABM1 and the signal spectrum. The noise measurement was performed after the scan with the signal, the same happened, just with the voice signal switched off. The ABM2 was calculated from this second scan.
- 8) All results resulting from a measurement point in a T-Coil job were calculated from the signal samples during this window interval. ABM values were averaged over the sequence of there samples.
- 9) At an optimal point measurement, the SNR ($S+N/N$) was calculated for perpendicular and transverse orientation, and the frequency response was measured for perpendicular.
- 10) Corrected for the frequency response after the DUT measurement since the DASY5 system had known the spectrum of the input signal by using a reference job.
- 11) In SEMCAD post processing, the spectral points are in addition scaled with the high-pass (half-band) and the A-weighting, bandwidth compensated factor (BWC) and those results are final as shown in this report.
- 12) A validation of the test setup and instrumentation may be performed using a TMFS or Helmholtz coil. Measure the emissions and confirm that they are within the specified tolerance.

7. T-Coil Performance Requirements

In order to be rated for T-Coil use, a WD shall meet the requirements for signal level and signal quality contained in this part.

7.1. T-Coil coupling field intensity

When measured as specified in ANSI C63.19, the T-Coil signal shall be ≥ -18 dB (A/m) at 1 kHz, in a 1/3 octave band filter for all orientations.

7.2. Frequency response

The frequency response of the axial component of the magnetic field, measured in 1/3 octave bands, shall follow the response curve specified in this sub-clause, over the frequency range 300 Hz to 3000 Hz. Figure 7.1 and Figure 7.2 provide the boundaries for the specified frequency. These response curves are for true field strength measurements of the T-Coil signal. Thus the 6 dB/octave probe response has been corrected from the raw readings.

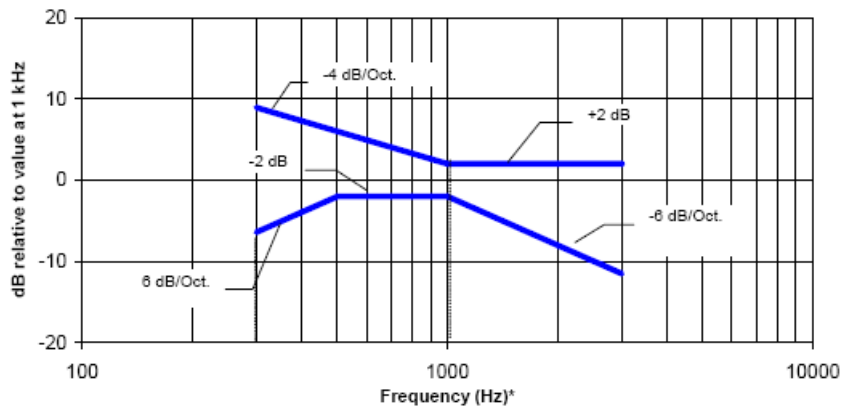

NOTE—Frequency response is between 300 Hz and 3000 Hz.

Figure 7.1—Magnetic field frequency response for WDs with a field ≤ -15 dB (A/m) at 1 kHz

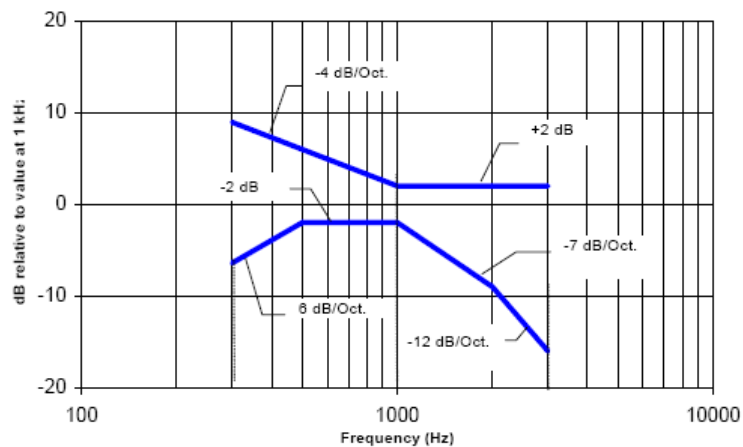

NOTE—Frequency response is between 300 Hz and 3000 Hz.

Figure 7.2—Magnetic field frequency response for WDs with a field that exceeds -15 dB(A/m) at 1 kHz

7.3. Signal quality

This part provides the signal quality requirement for the intended T-Coil signal from a WD. Only the RF immunity of the hearing aid is measured in T-Coil mode. It is assumed that a hearing aid can have no immunity to an interference signal in the audio band, which is the intended reception band for this mode. So, the only criteria that can be measured is the RF immunity in T-Coil mode. This is measured using the same procedure as for the audio coupling mode and at the same levels.

The worst signal quality of the three T-Coil signal measurements shall be used to determine the T-Coil mode category per Table 1

Table 1: T-Coil signal quality categories

Category	Telephone parameters WD signal quality [(signal + noise) – to – noise ratio in decibels]
Category T1	0 dB to 10 dB
Category T2	10 dB to 20 dB
Category T3	20 dB to 30 dB
Category T4	> 30 dB

8. T-Coil testing for CMRS Voice

General Note:

1. The middle channel of each frequency band is used for T-Coil testing according ANSI C63.19 2011.
2. Choose worst case from radio configuration investigation. After investigation was performed to determine the audio codec configuration to be used for testing, the following tests results which the worst case codec would be remarked to be used for the testing for the handset.

8.1. GSM Tests Results

<Codec Investigation>

Codec	FR VR	HR V1	Orientation	Band / Channel
ABM 1 (dBA/m)	-5.95	-4.15	Axial	GSM850 / 190
ABM 2 (dBA/m)	-37.80	-37.31		
SNR (dB)	31.85	33.16		
Freq. Response	Pass	Pass		

<Summary Tests Results>

Plot No.	Band	Antenna	Mode	Channel	Probe Position	ABM1 dB(A/m)	ABM2 dB(A/m)	SNR (dB)	T Rating	Frequency Response
1	GSM850	Ant.1	CMRS Voice	190	Axial (Z)	-5.95	-37.80	31.85	T4	Pass
					Transverse (Y)	-12.53	-42.16	29.63	T3	
2	GSM850	Ant.2	CMRS Voice	190	Axial (Z)	-4.61	-35.26	30.65	T4	Pass
					Transverse (Y)	-15.97	-45.33	29.36	T3	
3	GSM1900	Ant.0	CMRS Voice	661	Axial (Z)	-4.44	-38.47	34.03	T4	Pass
					Transverse (Y)	-14.16	-44.98	30.82	T4	
4	GSM1900	Ant.2	CMRS Voice	661	Axial (Z)	-6.22	-39.34	33.12	T4	Pass
					Transverse (Y)	-13.08	-44.47	31.39	T4	



8.2. WCDMA Tests Results

<Codec Investigation>

Codec	AMR 12.2Kbps	AMR 7.95Kbps	AMR 4.75Kbps	Orientation	Band / Channel
ABM 1 (dBA/m)	-1.64	-0.71	-0.08	Axial	Band 2 / 9400
ABM 2 (dBA/m)	-51.76	-51.50	-51.64		
SNR (dB)	50.12	50.79	51.56		
Freq. Response	Pass	Pass	Pass		

<Summary Tests Results>

Plot No.	Band	Antenna	Mode	Channel	Probe Position	ABM1 dB(A/m)	ABM2 dB(A/m)	SNR (dB)	T Rating	Frequency Response
5	WCDMA Band 2	Ant.0	AMR 12.2Kbps	9400	Axial (Z)	-1.64	-51.76	50.12	T4	Pass
					Transverse (Y)	-11.23	-51.38	40.15	T4	
6	WCDMA Band 2	Ant.2	AMR 12.2Kbps	9400	Axial (Z)	-1.69	-51.71	50.02	T4	Pass
					Transverse (Y)	-11.38	-51.36	39.98	T4	
7	WCDMA Band 4	Ant.0	AMR 12.2Kbps	1413	Axial (Z)	-1.72	-51.52	49.80	T4	Pass
					Transverse (Y)	-11.70	-51.46	39.76	T4	
8	WCDMA Band 4	Ant.2	AMR 12.2Kbps	1413	Axial (Z)	-1.57	-51.48	49.91	T4	Pass
					Transverse (Y)	-11.98	-52.07	40.09	T4	
9	WCDMA Band 5	Ant.1	AMR 12.2Kbps	4182	Axial (Z)	-1.55	-51.19	49.64	T4	Pass
					Transverse (Y)	-11.97	-51.64	39.67	T4	
10	WCDMA Band 5	Ant.2	AMR 12.2Kbps	4182	Axial (Z)	-1.63	-51.68	50.05	T4	Pass
					Transverse (Y)	-11.26	-51.35	40.09	T4	

9. T-Coil testing for VoLTE

9.1. Test System Setup for VoLTE over IMS T-coil Testing

The general test setup used for VoLTE over IMS is shown below. The callbox used when performing VoLTE over IMS T-coil measurements is a CMW500. The Data Application Unit (DAU) of the CMW500 was used to simulate the IP Multimedia Subsystem (IMS) server. According to C63 and KDB 285076 D02v03, VoLTE input level is -20dBm0.

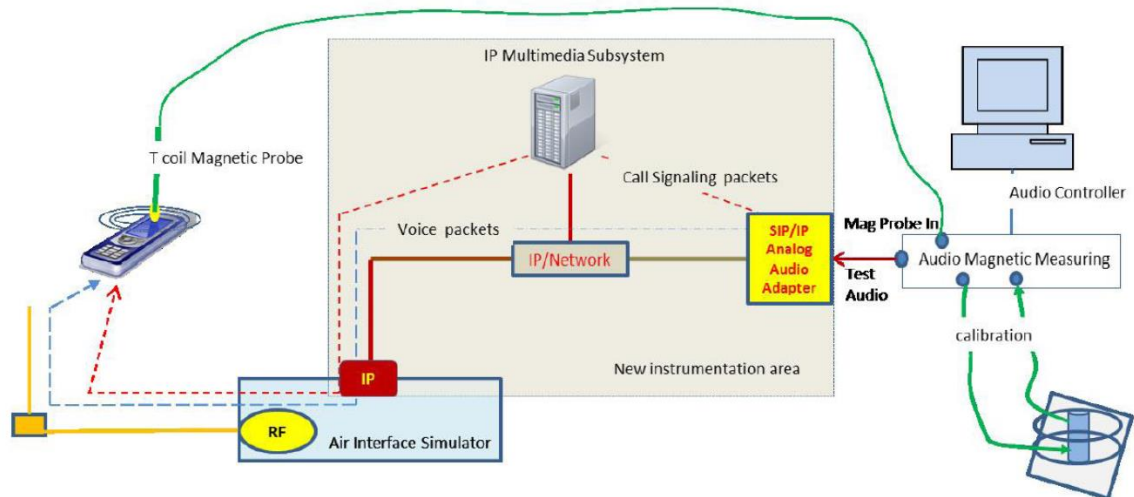

Figure 9.1 Test Setup for VoLTE over IMS T-coil Measurements

No correction gain factors were measured for VoLTE due to the Rohde & Schwarz CMW500, hosting a calibrated audio board. The gains used to measure VoLTE are set to 100.

The following software/firmware was used to simulate the VoLTE server for testing:

Firmware	License Keys	Software Name
V3.7.50 for LTE	KS500	LTE FDD R8 SIG BASIC
	KS550	LTE TDD R8 SIG BASIC
	KA100	IP APPL ENABLING IPv4
	KA150	IP APPL ENABLING IPv6
V3.7.20 for Audio	KAA20	IP APPL IMS BASIC
	KM050	DATAAPPL MEAS
	KS104	EVS SPEECH CODEC



9.2. Codec Configuration

An investigation was performed to determine the audio codec configuration to be used for testing. WB AMR 6.6Kbps setting was used for the audio codec on the CMW500 for VoLTE over IMS T-coil testing. See below table for comparisons between different codecs and codec data rates:

<AMR Codec Investigation>

Codec	NB AMR 4.75Kbps	NB AMR 12.2Kbps	WB AMR 6.6Kbps	WB AMR 23.85Kbps	Orientation	Band / BW / Channel
ABM 1 (dBA/m)	0.59	0.87	-0.36	0.42	Axial	LTE Band 25 / 20M / 263650
ABM 2 (dBA/m)	-46.05	-45.93	-46.47	-46.09		
SNR (dB)	46.64	46.80	46.11	46.51		
Freq. Response	Pass	Pass	Pass	Pass		

<EVS Codec Investigation>

Codec	EVS NB 5.9Kbps	EVS NB 24.4Kbps	EVS WB 5.9Kbps	EVS WB 128Kbps	Orientation	Band / BW / Channel
ABM 1 (dBA/m)	1.08	1.48	0.91	1.25	Axial	LTE Band 25 / 20M / 263650
ABM 2 (dBA/m)	-46.01	-45.98	-45.92	-45.96		
SNR (dB)	47.09	47.46	46.83	47.21		
Freq. Response	Pass	Pass	Pass	Pass		

9.3. Radio Configuration

An investigation was performed to determine the modulation, the bandwidth configuration and RB configuration to be used for testing. For LTE-FDD bands, 10MHz BW, QPSK, 1RB, 0RB offset was used for the testing as the worst-case configuration for the handset. For LTE-TDD bands, 10MHz BW, QPSK, 1RB, 0RB offset was used for the testing as the worst-case configuration for the handset. See below table for comparisons between different radio configurations:

<Radio Configuration Investigation>-FDD

Band	Bandwidth (MHz)	Modulation	RB size	RB offset	channel	ABM1 dB (A/m)	ABM2 dB(A/m)	SNR (dB)
LTE Band 25	20	QPSK	1	0	26365	-0.47	-46.56	46.09
LTE Band 25	20	QPSK	50	0	26365	-0.21	-47.09	46.88
LTE Band 25	20	QPSK	100	0	26365	-0.05	-47.53	47.48
LTE Band 25	20	16QAM	1	0	26365	-0.38	-47.39	47.01
LTE Band 25	15	QPSK	1	0	26365	-1.11	-46.04	44.93
LTE Band 25	10	QPSK	1	0	26365	-1.84	-46.52	44.68
LTE Band 25	5	QPSK	1	0	26365	-1.73	-46.55	44.82
LTE Band 25	3	QPSK	1	0	26365	-1.69	-46.88	45.19
LTE Band 25	1.4	QPSK	1	0	26365	-1.16	-47.21	46.05

<Radio Configuration Investigation>-TDD

Band	Bandwidth (MHz)	Modulation	RB size	RB offset	channel	UL-DL Configuration	ABM1 dB (A/m)	ABM2 dB(A/m)	SNR (dB)
LTE Band 41	20	QPSK	1	0	40620	0	-0.25	-35.96	35.71
LTE Band 41	20	QPSK	50	0	40620	0	0.16	-36.06	36.22
LTE Band 41	20	QPSK	100	0	40620	0	-0.10	-36.04	35.94
LTE Band 41	20	16QAM	1	0	40620	0	0.18	-36.25	36.43
LTE Band 41	20	64QAM	1	0	40620	0	0.43	-36.59	37.02
LTE Band 41	15	QPSK	1	0	40620	0	0.34	-36.61	36.95
LTE Band 41	10	QPSK	1	0	40620	0	-0.46	-35.69	35.23
LTE Band 41	5	QPSK	1	0	40620	0	-0.17	-35.83	35.66
LTE Band 41	10	QPSK	1	0	40620	1	0.04	-36.01	36.05
LTE Band 41	10	QPSK	1	0	40620	2	0.27	-35.96	36.23
LTE Band 41	10	QPSK	1	0	40620	3	0.13	-36.56	36.69
LTE Band 41	10	QPSK	1	0	40620	4	0.78	-36.55	37.33
LTE Band 41	10	QPSK	1	0	40620	5	0.59	-36.57	37.16
LTE Band 41	10	QPSK	1	0	40620	6	0.43	-36.28	36.71



9.4. VoLTE Tests Results

<Summary Tests Results>

Plot No.	Band	Antenna	Mode	Channel	Probe Position	ABM1 dB(A/m)	ABM2 dB(A/m)	SNR (dB)	T Rating	Frequency Response
11	LTE Band 7	Ant.0	QPSK_1RB_0	21100	Axial (Z)	-1.81	-46.58	44.77	T4	Pass
					Transverse (Y)	-13.56	-49.25	35.69	T4	
12	LTE Band 7	Ant.2	QPSK_1RB_0	21100	Axial (Z)	-1.50	-42.70	41.20	T4	Pass
					Transverse (Y)	-12.29	-43.99	31.70	T4	
13	LTE Band 12	Ant.1	QPSK_1RB_0	23095	Axial (Z)	-2.21	-47.99	45.78	T4	Pass
					Transverse (Y)	-11.76	-49.34	37.58	T4	
14	LTE Band 12	Ant.2	QPSK_1RB_0	23095	Axial (Z)	-2.07	-49.69	47.62	T4	Pass
					Transverse (Y)	-13.04	-50.84	37.80	T4	
15	LTE Band 13	Ant.1	QPSK_1RB_0	23230	Axial (Z)	-1.26	-43.62	42.36	T4	Pass
					Transverse (Y)	-12.60	-45.76	33.16	T4	
16	LTE Band 13	Ant.2	QPSK_1RB_0	23230	Axial (Z)	-2.24	-48.30	46.06	T4	Pass
					Transverse (Y)	-13.52	-50.68	37.16	T4	
17	LTE Band 25	Ant.0	QPSK_1RB_0	26365	Axial (Z)	-1.91	-46.30	44.39	T4	Pass
					Transverse (Y)	-13.15	-48.29	35.14	T4	
18	LTE Band 25	Ant.2	QPSK_1RB_0	26365	Axial (Z)	-1.69	-42.80	41.11	T4	Pass
					Transverse (Y)	-12.77	-44.17	31.40	T4	
19	LTE Band 26	Ant.1	QPSK_1RB_0	26865	Axial (Z)	-1.18	-47.48	46.30	T4	Pass
					Transverse (Y)	-11.81	-48.64	36.83	T4	
20	LTE Band 26	Ant.2	QPSK_1RB_0	26865	Axial (Z)	-1.85	-47.26	45.41	T4	Pass
					Transverse (Y)	-12.72	-50.89	38.17	T4	
21	LTE Band 66	Ant.0	QPSK_1RB_0	132322	Axial (Z)	-1.59	-48.05	46.46	T4	Pass
					Transverse (Y)	-12.32	-49.20	36.88	T4	
22	LTE Band 66	Ant.2	QPSK_1RB_0	132322	Axial (Z)	-1.58	-43.40	41.82	T4	Pass
					Transverse (Y)	-12.41	-44.54	32.13	T4	
23	LTE Band 71	Ant.1	QPSK_1RB_0	133322	Axial (Z)	-0.74	-45.20	44.46	T4	Pass
					Transverse (Y)	-12.24	-45.80	33.56	T4	
24	LTE Band 71	Ant.2	QPSK_1RB_0	133322	Axial (Z)	-1.72	-49.88	48.16	T4	Pass
					Transverse (Y)	-13.16	-50.72	37.56	T4	
25	LTE Band 41 PC3	Ant.0	QPSK_1RB_0	40620	Axial (Z)	-2.43	-38.53	36.10	T4	Pass
					Transverse (Y)	-15.62	-44.15	28.53	T3	
26	LTE Band 41 PC3	Ant.2	QPSK_1RB_0	40620	Axial (Z)	-3.80	-38.72	34.92	T4	Pass
					Transverse (Y)	-14.56	-42.64	28.08	T3	
27	LTE Band 41 PC2	Ant.0	QPSK_1RB_0	40620	Axial (Z)	-0.87	-35.90	35.03	T4	Pass
					Transverse (Y)	-11.76	-39.62	27.86	T3	
28	LTE Band 41 PC2	Ant.2	QPSK_1RB_0	40620	Axial (Z)	-1.25	-36.08	34.83	T4	Pass
					Transverse (Y)	-11.76	-39.27	27.51	T3	
29	LTE Band 42 Part 27Q	Ant.0	QPSK_1RB_0	42590	Axial (Z)	-4.25	-44.50	40.25	T4	Pass
					Transverse (Y)	-12.30	-46.96	34.66	T4	
30	LTE Band 42 Part 27Q	Ant.5	QPSK_1RB_0	42590	Axial (Z)	-3.82	-44.47	40.65	T4	Pass
					Transverse (Y)	-10.46	-45.28	34.82	T4	
31	LTE Band 48 Part 96	Ant.0	QPSK_1RB_0	55990	Axial (Z)	-3.80	-45.36	41.56	T4	Pass
					Transverse (Y)	-10.11	-45.99	35.88	T4	
32	LTE Band 48 Part 96	Ant.5	QPSK_1RB_0	55990	Axial (Z)	-3.23	-44.55	41.32	T4	Pass
					Transverse (Y)	-11.07	-46.78	35.71	T4	

Note:

1. HAC T-Coil for LTE Band 2 is covered by LTE Band 25 due to similar frequency range, same maximum tune-up limit and same channel bandwidth.
2. HAC T-Coil for LTE Band 4 is covered by LTE Band 66 due to similar frequency range, same maximum tune-up limit and same channel bandwidth.
3. HAC T-Coil for LTE Band 5 is covered by LTE Band 26 due to similar frequency range, same maximum tune-up limit and same channel bandwidth.
4. HAC T-Coil for LTE Band 17 is covered by LTE Band 12 due to similar frequency range, same maximum tune-up limit and same channel bandwidth.
5. HAC T-Coil for LTE Band 38 is covered by LTE Band 41 PC3 due to similar frequency range, same maximum tune-up limit and same channel bandwidth.
6. HAC T-Coil for LTE Band 42(3550-3600MHz)/LTE Band 43(3600-3700MHz) is covered by LTE Band 48 Part 96 due to similar frequency range, same maximum tune-up limit and same channel bandwidth.



10. T-Coil testing for VoNR

10.1. Test Data Summary

General Notes:

The yellow highlight section request for reuse.

1. According to KDB 285076 D03, for 5G Sub 6 calls that use the same protocol, Codec(s) and reference level as VoLTE over LTE (i.e. -16 dBm0).
2. For LTE, establish the ABM1S65G value by using the ABM1LTE magnetic intensity for an LTE call in the same band as the 5G sub6 band under test.
3. For VoNR, establish the ABM1S65G value by using an IP connection for magnetic intensity for a call in the same band as the 5G sub6 band under test.
4. Also note the actual ABM2LTE value and establish an ABM2S65G value, using a 5G manufacture test mode over 5G Sub6 channels for the same band under test.
5. Document in the test report matrix:
 - a. Include columns for both ABM2LTE & ABM2S65G for comparison
 - b. Establish the S+N1/N2 for the rating
 - i. S+N1 = ABM1LTE (step 1) and
 - ii. N2 = ABM2S65G (step 2).
 - iii. Subtract 3 dB from S+N1/N2
 - c. Rating based on (ABM1LTEI / ABM2S65G) -3dB.



<Summary Tests Results>

Plot No.	Band	Antenna	Mode	Channel	Probe Position	ABM1 dB(A/m)	ABM2 dB(A/m)	SNR (dB)	T Rating	Frequency Response
19	LTE Band 26	Ant.1	QPSK_1RB_0	26865	Axial (Z)	-1.18	-47.48	46.30	T4	Pass
					Transverse (Y)	-11.81	-48.64	36.83	T4	
/	NR n5	Ant.1	QPSK_50@25	167300	Axial (Z)	-1.18	-52.00	47.82	T4	NA
					Transverse (Y)	-11.81	-52.58	37.77	T4	
20	LTE Band 26	Ant.2	QPSK_1RB_0	26865	Axial (Z)	-1.85	-47.26	45.41	T4	Pass
					Transverse (Y)	-12.72	-50.89	38.17	T4	
/	NR n5	Ant.2	QPSK_50@25	167300	Axial (Z)	-1.85	-49.66	44.81	T4	NA
					Transverse (Y)	-12.72	-50.82	35.10	T4	
11	LTE Band 7	Ant.0	QPSK_1RB_0	21100	Axial (Z)	-1.81	-46.58	44.77	T4	Pass
					Transverse (Y)	-13.56	-49.25	35.69	T4	
/	NR n7	Ant.0	QPSK_50@25	507000	Axial (Z)	-1.81	-48.74	43.93	T4	NA
					Transverse (Y)	-13.56	-49.34	32.78	T4	
12	LTE Band 7	Ant.2	QPSK_1RB_0	21100	Axial (Z)	-1.50	-42.70	41.20	T4	Pass
					Transverse (Y)	-12.29	-43.99	31.70	T4	
/	NR n7	Ant.2	QPSK_50@25	507000	Axial (Z)	-1.50	-49.44	44.94	T4	NA
					Transverse (Y)	-12.29	-51.39	36.10	T4	
17	LTE Band 25	Ant.0	QPSK_1RB_0	26365	Axial (Z)	-1.91	-46.30	44.39	T4	Pass
					Transverse (Y)	-13.15	-48.29	35.14	T4	
/	NR n25	Ant.0	QPSK_50@25	376500	Axial (Z)	-1.91	-46.30	41.39	T4	NA
					Transverse (Y)	-13.15	-48.43	32.28	T4	
18	LTE Band 25	Ant.2	QPSK_1RB_0	26365	Axial (Z)	-1.69	-42.80	41.11	T4	Pass
					Transverse (Y)	-12.77	-44.17	31.40	T4	
/	NR n25	Ant.2	QPSK_50@25	376500	Axial (Z)	-1.69	-42.79	38.10	T4	NA
					Transverse (Y)	-12.77	-44.31	28.54	T3	
25	LTE Band 41 PC3	Ant.0	QPSK_1RB_0	40620	Axial (Z)	-2.43	-38.53	36.10	T4	Pass
					Transverse (Y)	-15.62	-44.15	28.53	T3	
/	NR n41 PC3	Ant.0	QPSK_135@67	518598	Axial (Z)	-2.43	-52.12	46.69	T4	NA
					Transverse (Y)	-15.62	-52.73	34.11	T4	
30	LTE Band 42 Part 27Q	Ant.5	QPSK_1RB_0	42590	Axial (Z)	-3.82	-44.47	40.65	T4	Pass
					Transverse (Y)	-10.46	-45.28	34.82	T4	
/	NR n41 PC3	Ant.5	QPSK_135@67	518598	Axial (Z)	-3.82	-51.98	45.16	T4	NA
					Transverse (Y)	-10.46	-51.18	37.72	T4	
27	LTE Band 41 PC2	Ant.0	QPSK_1RB_0	40620	Axial (Z)	-0.87	-35.90	35.03	T4	Pass
					Transverse (Y)	-11.76	-39.62	27.86	T3	
/	NR n41 PC2	Ant.0	QPSK_135@67	518598	Axial (Z)	-0.87	-52.16	48.29	T4	NA
					Transverse (Y)	-11.76	-48.94	34.18	T4	
30	LTE Band 42 Part 27Q	Ant.5	QPSK_1RB_0	42590	Axial (Z)	-3.82	-44.47	40.65	T4	Pass
					Transverse (Y)	-10.46	-45.28	34.82	T4	
/	NR n41 PC2	Ant.5	QPSK_135@67	518598	Axial (Z)	-3.82	-53.43	46.61	T4	NA
					Transverse (Y)	-10.46	-47.89	34.43	T4	
31	LTE Band 48	Ant.0	QPSK_1RB_0	55990	Axial (Z)	-3.80	-45.36	41.56	T4	Pass
					Transverse (Y)	-10.11	-45.99	35.88	T4	
/	NR n48	Ant.0	QPSK_50@25	641666	Axial (Z)	-3.80	-51.80	45.00	T4	NA
					Transverse (Y)	-10.11	-51.46	38.35	T4	
32	LTE Band 48	Ant.5	QPSK_1RB_0	55990	Axial (Z)	-3.23	-44.55	41.32	T4	Pass
					Transverse (Y)	-11.07	-46.78	35.71	T4	
/	NR n48	Ant.5	QPSK_50@25	641666	Axial (Z)	-3.23	-52.34	46.11	T4	NA
					Transverse (Y)	-11.07	-52.17	38.10	T4	
21	LTE Band 66	Ant.0	QPSK_1RB_0	132322	Axial (Z)	-1.59	-48.05	46.46	T4	Pass
					Transverse (Y)	-12.32	-49.20	36.88	T4	
/	NR n66	Ant.0	QPSK_108@54	349000	Axial (Z)	-1.59	-49.76	45.17	T4	NA
					Transverse (Y)	-12.32	-51.33	36.01	T4	
22	LTE Band 66	Ant.2	QPSK_1RB_0	132322	Axial (Z)	-1.58	-43.40	41.82	T4	Pass
					Transverse (Y)	-12.41	-44.54	32.13	T4	
/	NR n66	Ant.2	QPSK_108@54	349000	Axial (Z)	-1.58	-49.28	44.70	T4	NA
					Transverse (Y)	-12.41	-50.93	35.52	T4	
23	LTE Band 71	Ant.0	QPSK_1RB_0	133322	Axial (Z)	-0.74	-45.20	44.46	T4	Pass
					Transverse (Y)	-12.24	-45.80	33.56	T4	
/	NR n71	Ant.0	QPSK_50@25	136100	Axial (Z)	-0.74	-50.47	46.73	T4	NA
					Transverse (Y)	-12.24	-51.63	36.39	T4	
24	LTE Band 71	Ant.2	QPSK_1RB_0	133322	Axial (Z)	-1.72	-49.88	48.16	T4	Pass
					Transverse (Y)	-13.16	-50.72	37.56	T4	
/	NR n71	Ant.2	QPSK_50@25	136100	Axial (Z)	-1.72	-38.37	33.65	T4	NA
					Transverse (Y)	-13.16	-43.64	27.48	T3	
29	LTE Band 42 Part 27Q	Ant.0	QPSK_1RB_0	42590	Axial (Z)	-4.25	-44.50	40.25	T4	Pass
					Transverse (Y)	-12.30	-46.96	34.66	T4	
/	NR n77 PC3 Part 27Q	Ant.0	QPSK_135@67	650000	Axial (Z)	-4.25	-51.80	44.55	T4	NA
					Transverse (Y)	-12.30	-52.23	36.93	T4	
30	LTE Band 42 Part 27Q	Ant.5	QPSK_1RB_0	42590	Axial (Z)	-3.82	-44.47	40.65	T4	Pass
					Transverse (Y)	-10.46	-45.28	34.82	T4	
/	NR n77 PC3 Part 27Q	Ant.5	QPSK_135@67	650000	Axial (Z)	-3.82	-52.10	45.28	T4	NA
					Transverse (Y)	-10.46	-51.60	38.14	T4	



31	LTE Band 48 Part 96	Ant.0	QPSK_1RB_0	55990	Axial (Z)	-3.80	-45.36	41.56	T4	Pass
					Transverse (Y)	-10.11	-45.99	35.88	T4	
/	NR n77 PC3 Part 27Q	Ant.0	QPSK_135@67	650000	Axial (Z)	-3.80	-51.80	45.00	T4	NA
					Transverse (Y)	-10.11	-51.54	38.43	T4	
32	LTE Band 48 Part 96	Ant.5	QPSK_1RB_0	55990	Axial (Z)	-3.23	-44.55	41.32	T4	Pass
					Transverse (Y)	-11.07	-46.78	35.71	T4	
/	NR n77 PC3 Part 27Q	Ant.5	QPSK_135@67	650000	Axial (Z)	-3.23	-52.34	46.11	T4	NA
					Transverse (Y)	-11.07	-52.17	38.10	T4	
29	LTE Band 42 Part 27Q	Ant.0	QPSK_1RB_0	42590	Axial (Z)	-4.25	-44.50	40.25	T4	Pass
					Transverse (Y)	-12.30	-46.96	34.66	T4	
/	NR n78 PC2 Part 27Q	Ant.0	QPSK_135@67	636666	Axial (Z)	-4.25	-49.60	42.35	T4	NA
					Transverse (Y)	-12.30	-52.31	37.01	T4	
30	LTE Band 42 Part 27Q	Ant.5	QPSK_1RB_0	42590	Axial (Z)	-3.82	-44.47	40.65	T4	Pass
					Transverse (Y)	-10.46	-45.28	34.82	T4	
/	NR n78 PC2 Part 27Q	Ant.5	QPSK_135@67	636666	Axial (Z)	-3.82	-51.21	44.39	T4	NA
					Transverse (Y)	-10.46	-51.33	37.87	T4	

Note:

1. HAC T-Coil for NR n2 is covered by NR n25 due to similar frequency range, same maximum tune-up limit and same channel bandwidth.
2. HAC T-Coil for NR n38 is covered by NR n41 PC3 due to similar frequency range, same maximum tune-up limit and same channel bandwidth.
3. HAC T-Coil for NR n78 PC3 Part 27Q is covered by NR n77 PC3 Part 27Q due to similar frequency range, same maximum tune-up limit and same channel bandwidth.

11. T-Coil testing for VoWiFi

11.1. Test System Setup for VoWiFi over IMS T-coil Testing

The general test setup used for VoWiFi over IMS, or CMRS WiFi Calling, is shown below. The callbox used when performing VoWiFi over IMS T-coil measurements is a CMW500. The Data Application Unit (DAU) of the CMW500 was used to simulate the IP Multimedia Subsystem (IMS) server.

According to C63 and KDB 285076 D02v03, VoWiFi input level is -20dBm0.

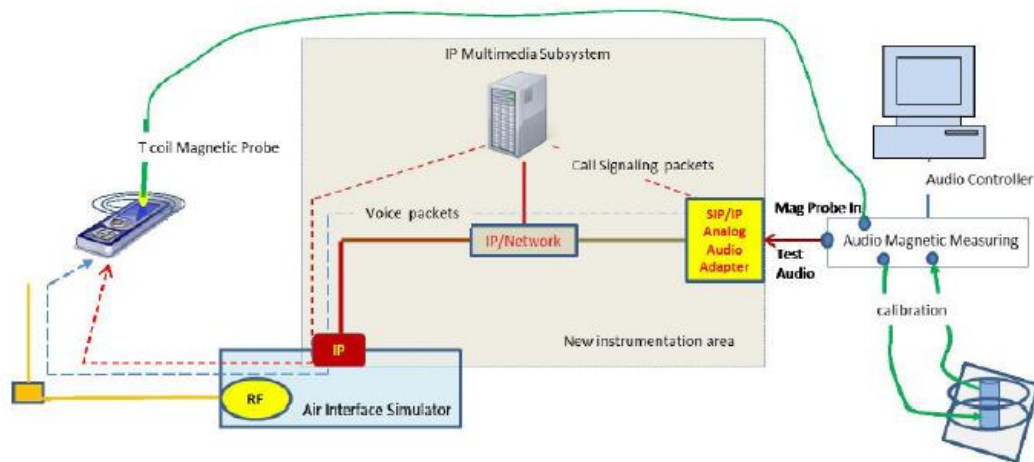

Figure 10.1 Test Setup for VoWiFi over IMS T-coil Measurements

No correction gain factors were measured for VoWiFi due to the Rohde & Schwarz CMW500, hosting a calibrated audio board. The gains used to measure VoWiFi are set to 100.

Firmware	License Keys	Software Name
V3.7.40 for WLAN	KS650	WLAN A/B/G SIG BASIC
	KS651	WLAN N SIG BASIC
	KA100	IP APPL ENABLING IPv4
	KA150	IP APPL ENABLING IPv6
V3.7.20 for Audio	KAA20	IP APPL IMS BASIC
	KM050	DATA APPL MEAS
	KS104	EVS SPEECH CODEC



11.2. Codec Configuration

An investigation was performed to determine the audio codec configuration to be used for testing. EVS WB 5.9Kbps setting was used for the audio codec on the CMW500 for VoWiFi over IMS T-coil testing. See below table for comparisons between different codecs and codec data rates:

<AMR Codec Investigation>

Codec	NB AMR 4.75Kbps	NB AMR 12.2Kbps	WB AMR 6.6Kbps	WB AMR 23.85Kbps	Orientation	Band / BW / Channel
ABM 1 (dBA/m)	-3.13	-4.05	-3.77	-4.52	Axial	WLAN 2.4G / 20 / 6
ABM 2 (dBA/m)	-48.39	-48.78	-48.16	-48.50		
SNR (dB)	45.26	44.73	44.39	43.98		
Freq. Response	Pass	Pass	Pass	Pass		

<EVS Codec Investigation>

Codec	EVS NB 5.9Kbps	EVS NB 24.4Kbps	EVS WB 5.9Kbps	EVS WB 128Kbps	Orientation	Band / BW / Channel
ABM 1 (dBA/m)	-4.73	-4.10	-5.33	-4.56	Axial	WLAN 2.4G / 20 / 6
ABM 2 (dBA/m)	-48.53	-48.36	-48.68	-48.47		
SNR (dB)	43.80	44.26	43.35	43.91		
Freq. Response	Pass	Pass	Pass	Pass		



11.3. Radio Configuration

An investigation was performed on all applicable data rates and modulations to determine the radio configuration to be used for testing. See below table for comparisons between different radios configurations in each 802.11 standard:

Mode	Bandwidth	Data rate	Channel	ABM1 dB (A/m)	ABM2 dB (A/m)	SNR (dB)
WLAN 2.4GHz						
802.11b	20	1M	6	-5.33	-48.68	43.35
802.11b	20	11M	6	-4.13	-48.83	44.70
802.11g	20	6M	6	-5.05	-48.67	43.62
802.11g	20	54M	6	-3.29	-48.54	45.25
802.11n	20	MCS0	6	-4.37	-48.46	44.09
802.11n	20	MCS7	6	-3.05	-48.87	45.82
802.11n	40	MCS0	6	-3.88	-48.24	44.36
802.11n	40	MCS7	6	-2.75	-48.69	45.94
WLAN 5GHz						
802.11a	20	6M	40	-3.72	-45.78	42.06
802.11a	20	54M	40	-2.14	-45.36	43.22
802.11n	20	MCS0	40	-3.18	-45.69	42.51
802.11n	20	MCS7	40	-1.73	-45.77	44.04
802.11n	40	MCS0	38	-2.88	-45.83	42.95
802.11n	40	MCS7	38	-1.50	-45.79	44.29
802.11ac	20	MCS0	40	-2.03	-45.61	43.58
802.11ac	20	MCS8	40	-1.24	-45.79	44.55
802.11ac	40	MCS0	38	-1.73	-45.45	43.72
802.11ac	40	MCS9	38	-1.19	-45.88	44.69
802.11ac	80	MCS0	42	-1.55	-45.72	44.17
802.11ac	80	MCS9	42	-1.43	-45.53	44.10

11.4. VoWiFi Tests Results

<Summary Tests Results>

Plot No.	Band	Antenna	Mode	Channel	Probe Position	ABM1 dB(A/m)	ABM2 dB(A/m)	SNR (dB)	T Rating	Frequency Response
33	WLAN 2.4GHz	Ant.9	802.11b -1Mbps	6	Axial (Z)	-5.59	-48.77	43.18	T4	Pass
					Transverse (Y)	-12.75	-52.74	39.99	T4	
34	WLAN 5.2GHz	Ant.9	802.11a-6Mbps	40	Axial (Z)	-4.00	-45.85	41.85	T4	Pass
					Transverse (Y)	-12.44	-49.07	36.63	T4	
35	WLAN 5.3GHz	Ant.9	802.11a-6Mbps	56	Axial (Z)	-6.93	-50.12	43.19	T4	Pass
					Transverse (Y)	-15.09	-50.54	35.45	T4	
36	WLAN 5.5GHz	Ant.9	802.11a-6Mbps	124	Axial (Z)	-3.41	-50.80	47.39	T4	Pass
					Transverse (Y)	-12.49	-49.70	37.21	T4	
37	WLAN 5.8GHz	Ant.9	802.11a-6Mbps	157	Axial (Z)	-4.70	-50.47	45.77	T4	Pass
					Transverse (Y)	-15.80	-51.21	35.41	T4	

12. T-Coil testing for OTT VoIP Calling

12.1. Test System Setup for OTT VoIP T-coil Testing

OTT VoIP Application

Google Duo is a pre-installed application on the DUT which allows for VoIP calls in a head-to-ear scenario. Duo uses the OPUS audio codec and supports a bitrate range of 6kbps to 75kbps. All air interfaces capable of a data connection were evaluated with Google Duo. When HAC testing we are using the Google Duo version is 26.0.179825522.alpha.DEV and the bitrate configuration can find at settings → Voice call parameters settings → Audio codec bitrate(6-75kbps).

Test Procedure and Equipment Setup

The test procedure for OTT testing is identical to the section above, except for how the signal is sent to the DUT, as outlined in the diagram below.

The AMMI is connected to the support device's Mic via Audio Data Line. The support device is connected to the Internet via Wi-Fi and the DUT is connected to the mobile base station via the technology under test. Using the DUT's OTT application, a VoIP call is established with the support device. The test signal is sent from the DASY PC to the AMMI, from the AMMI to the support device, and finally to the DUT. To exercise the license antenna, the DUT was simultaneously connected to an external AP and to a mobile base station.

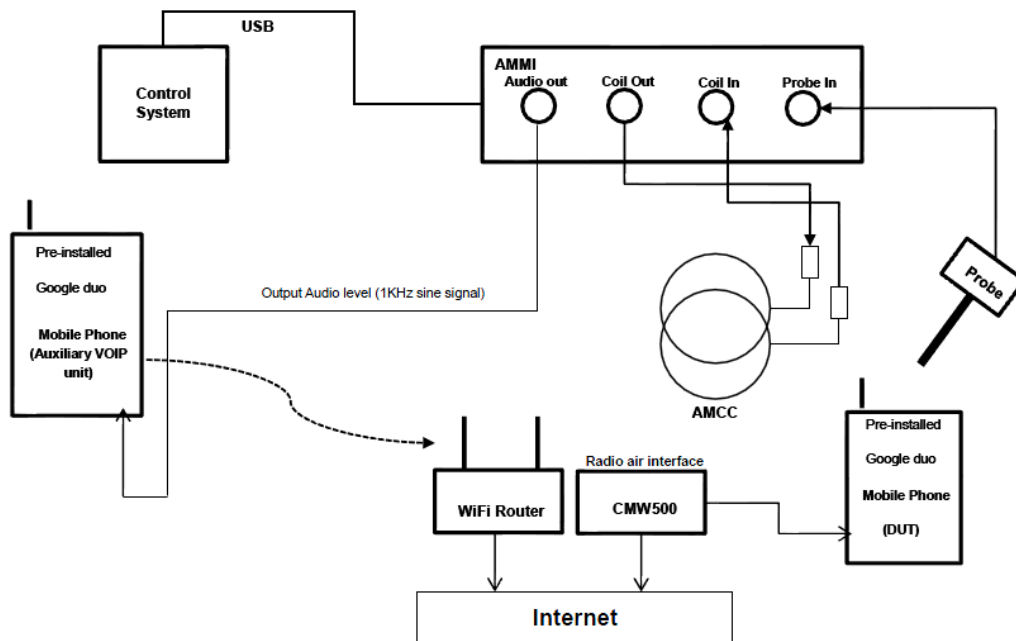



Audio Level Settings

According to KDB 285076 D02, the average speech level of -20dBm0 shall be used for protocols not specifically listed in Table 7.1 of ANSI C63.19-2001.

Determine Input Audio level is based on the Added additional dBFS level readout by Google Duo customizes application and three steps need to do.

1. Input a gain value to readout the -23dBFS level as reference. (0dBFS = 3.14 dBm0)
2. Adjust gain level to readout the dBFS level until it changes to -24dBFS.
3. Based on the step 1 and 2, and then calculate the gain value(dB) by interpolation to get the -20dBm0 corresponding gain value.

Codec Bit-rate Investigation

An investigation between the various bit-rate configurations (Low/Mid/High bit rates for Narrowband, Wideband, and EVS) are documented (ABM1, ABM2, SNNR, frequency response) to determine the worst case bit-rate for each voice service type. The tables below compare the varying bit-rate configurations

Air Interface Investigation

Using the worst-case bit-rate and Radio Configuration found in §9.2, a limited set of bands/channel/ bandwidths were then tested to confirm that there is no effect to the T-rating when changing the band/channel/bandwidth, it is necessary to report only a set band/channel/bandwidth for each orientation for a voice service/air interface.



12.2. Test Data Summary

<Codec Investigation>-EDGE

Codec	Bitrate 6Kbps	Bitrate 40Kbps	Bitrate 75Kbps	Orientation	Band / Channel
ABM 1 (dBA/m)	12.54	11.89	11.37	Axial	GSM850 / 1900
ABM 2 (dBA/m)	-44.31	-44.53	-44.61		
SNR (dB)	56.85	56.42	55.98		
Freq. Response	Pass	Pass	Pass		

For EDGE, it is observed that 75Kbps is the worst case.

<Codec Investigation>-HSPA

Codec	Bitrate 6Kbps	Bitrate 40Kbps	Bitrate 75Kbps	Orientation	Band / Channel
ABM 1 (dBA/m)	3.82	3.45	2.90	Axial	Band 5 / 4182
ABM 2 (dBA/m)	-43.96	-43.86	-44.05		
SNR (dB)	47.78	47.31	46.95		
Freq. Response	Pass	Pass	Pass		

For WCDMA, it is observed that 75Kbps is the worst case.

<Codec Investigation>-LTE

Codec	Bitrate 6Kbps	Bitrate 40Kbps	Bitrate 75Kbps	Orientation	Band / Channel
ABM 1 (dBA/m)	4.21	3.75	3.03	Axial	Band 41 / 40620
ABM 2 (dBA/m)	-38.88	-39.01	-39.12		
SNR (dB)	43.09	42.76	42.15		
Freq. Response	Pass	Pass	Pass		

For LTE, it is observed that 75Kbps is the worst case.

<Codec Investigation>-WLAN

Codec	Bitrate 6Kbps	Bitrate 40Kbps	Bitrate 75Kbps	Orientation	Band / Channel
ABM 1 (dBA/m)	0.53	0.16	-0.35	Axial	WLAN 2.4GHz / 6
ABM 2 (dBA/m)	-45.84	-45.66	-45.74		
SNR (dB)	46.37	45.82	45.39		
Freq. Response	Pass	Pass	Pass		

For WLAN, it is observed that 75Kbps is the worst case.



<Summary Tests Results>

Due to OTT service are all established over the internet protocol for the voice service, and on both services use the identical RF air interface, therefore according to the summary test results, the worst case air interface is used for OTT T-Coil testing.

Plot No.	Band	Antenna	Mode	Channel	Probe Position	ABM1 dB(A/m)	ABM2 dB(A/m)	SNR (dB)	T Rating	Frequency Response
38	GSM 850	Ant.2	EDGE	190	Axial (Z)	11.37	-44.61	55.98	T4	Pass
					Transverse (Y)	2.76	-47.06	49.82	T4	
39	WCDMA Band 5	Ant.1	HSPA	4182	Axial (Z)	2.90	-44.05	46.95	T4	Pass
					Transverse (Y)	-7.74	-47.76	40.02	T4	
40	LTE Band 42 PC2	Ant.2	QPSK	40620	Axial (Z)	3.03	-39.12	42.15	T4	Pass
					Transverse (Y)	-8.54	-41.94	33.40	T4	
41	LTE Band 71	Ant.2	QPSK	133322	Axial (Z)	5.47	-45.42	50.89	T4	Pass
					Transverse (Y)	-4.84	-48.36	43.52	T4	
42	WLAN 2.4GHz	Ant.9	802.11b	6	Axial (Z)	-0.35	-45.74	45.39	T4	Pass
					Transverse (Y)	-11.42	-46.35	34.93	T4	
43	WLAN 5GHz	Ant.9	802.11a	157	Axial (Z)	-0.29	-43.99	43.70	T4	Pass
					Transverse (Y)	-11.54	-45.40	33.86	T4	



12.3. 5G FR1 OTT evaluation

General Notes:

The yellow high light section request for reuse.

1. According to KDB 285076 D03, for 5G Sub 6 calls that use the same protocol, Codec(s) and reference level as OTT calls (such as Duo or AppleTalk).
2. For LTE, establish the ABM1S65G value by using the ABM1LTE magnetic intensity for an LTE call in the same band as the 5G sub6 band under test.
3. For OTT, establish the ABM1S65G value by using an IP connection for magnetic intensity for a call in the same band as the 5G sub6 band under test.
4. Also note the actual ABM2LTE/OTT value and establish an ABM2S65G value, using a 5G manufacture test mode over 5G Sub 6 channels for the same band under test.
5. Document in the test report matrix:
 - d. Include columns for both ABM2LTE & ABM2S65G for comparison
 - e. Establish the S+N1/N2 for the rating
 - iv. S+N1 = ABM1LTE (step 1) and
 - v. N2 = ABM2S65G (step 2).
 - vi. Subtract 3 dB from S+N1/N2
 - f. Rating based on (ABM1LTE / ABM2S65G) -3dB.

<Summary Tests Results>

Due to OTT service are all is established over the internet protocol for the voice service, and on both services use the identical RF air interface, therefore according to the summary test results, the worst case air interface is used for OTT T-Coil testing.

Plot No.	Band	Antenna	Mode	Channel	Probe Position	ABM1 dB(A/m)	ABM2 dB(A/m)	SNR (dB)	T Rating	Frequency Response
41	LTE Band 71	Ant.2	QPSK	133322	Axial (Z)	5.47	-45.42	50.89	T4	Pass
					Transverse (Y)	-4.84	-48.36	43.52	T4	
/	NR n71	Ant.2	QPSK_50@25	136100	Axial (Z)	5.47	-49.31	51.78	T4	NA
					Transverse (Y)	-4.84	-51.68	43.84	T4	

13. Measurement Uncertainty

No.	Error source	Type	Uncertainty Value a_i (%)	Prob. Dist.	Div.	ABM1 c_i	ABM2 c_i	Std. Unc. ABM1 u_i (%)	Std. Unc. ABM2 u_i (%)
1	System Repeatability	A	0.016	N	1	1	1	0.016	0.016
Probe Sensitivity									
2	Reference Level	B	3.0	R	$\sqrt{3}$	1	1	3.0	3.0
3	AMCC Geometry	B	0.4	R	$\sqrt{3}$	1	1	0.2	0.2
4	AMCC Current	B	0.6	R	$\sqrt{3}$	1	1	0.4	0.4
5	Probe Positioning during Calibration	B	0.1	R	$\sqrt{3}$	1	1	0.1	0.1
6	Noise Contribution	B	0.7	R	$\sqrt{3}$	0.0143	1	0.0	0.4
7	Frequency Slope	B	5.9	R	$\sqrt{3}$	0.1	1	0.3	3.5
Probe System									
8	Repeatability / Drift	B	1.0	R	$\sqrt{3}$	1	1	0.6	0.6
9	Linearity / Dynamic Range	B	0.6	N	1	1	1	0.4	0.4
10	Acoustic Noise	B	1.0	R	$\sqrt{3}$	0.1	1	0.1	0.6
11	Probe Angle	B	2.3	R	$\sqrt{3}$	1	1	1.4	1.4
12	Spectral Processing	B	0.9	R	$\sqrt{3}$	1	1	0.5	0.5
13	Integration Time	B	0.6	N	$\sqrt{3}$	1	5	0.6	3.0
14	Field Distribution	B	0.2	R	$\sqrt{3}$	1	1	0.1	0.1
Test Signal									
15	Ref. Signal Spectral Response	B	0.6	R	$\sqrt{3}$	0	1	0.0	0.4
Positioning									
16	Probe Positioning	B	1.9	R	$\sqrt{3}$	1	1	1.1	1.1
17	Phantom Thickness	B	0.9	R	$\sqrt{3}$	1	1	0.5	0.5
18	DUT Positioning	B	1.9	R	$\sqrt{3}$	1	1	1.1	1.1
External Contributions									
19	RF Interference	B	0.0	R	$\sqrt{3}$	1	0.3	0.0	0.0
20	Test Signal Variation	B	2.0	R	$\sqrt{3}$	1	1	1.2	1.2
Combined Std. Uncertainty (ABM Field)		$u_c = \sqrt{\sum_{i=1}^{20} c_i^2 u_i^2}$						4.1	6.1
Expanded Std. Uncertainty		$u_e = 2u_c$		N	$k = 2$		8.2	12.2	



14. Main Test Instruments

Table 14-1: List of Main Instruments

No.	Name	Type	Serial Number	Calibration Date	Valid Period
01	Audio Magnetic Calibration Coil	AMCC	1105	/	/
02	Audio Measuring Instrument	AMMI	1121	/	/
03	HAC Test Arch	N/A	1150	/	/
04	Audio Magnetic 1D Field Probe	AM1DV3	3086	2021-02-22	Three years
05	DAE	DAE4	786	2022-09-29	One year
06	BTS	CMW500	152499	2022-07-15	One year
07	Software	DASY5	/	/	/



ANNEX A: Test Plots

T-Coil GSM 850 Axial (Ant.1)

Date: 2023-2-8

Electronics: DAE4 Sn786

Medium: Air

Medium parameters used: $\sigma = 0$ S/m, $\epsilon_r = 1$; $\rho = 1$ kg/m³

Communication System: UID 0, GSM (0) Frequency: 836.6 MHz Duty Cycle: 1:8.3

Probe: AM1DV3 - 3086

z (axial) 4.2mm 50 x 50/ABM Interpolated Signal(x,y,z) (101x101x1): Interpolated grid:

dx=1.000 mm, dy=1.000 mm

Signal Type: Audio File (.wav) 48k_voice_1kHz_1s.wav

Output Gain: 100

Measure Window Start: 300ms

Measure Window Length: 1000ms

BWC applied: 0.15 dB

Device Reference Point: 0, 0, -6.3 mm

Cursor:

ABM1 = -1.16 dBA/m

BWC Factor = 0.15 dB

Location: 7, -10, 3.7 mm

z (axial) 4.2mm 50 x 50/ABM Interpolated SNR(x,y,z) (101x101x1): Interpolated grid: dx=1.000

mm, dy=1.000 mm

Signal Type: Audio File (.wav) 48k_voice_1kHz_1s.wav

Output Gain: 100

Measure Window Start: 300ms

Measure Window Length: 1000ms

BWC applied: 0.15 dB

Device Reference Point: 0, 0, -6.3 mm

Cursor:

ABM1/ABM2 = 31.85 dB

ABM1 comp = -5.95 dBA/m

BWC Factor = 0.15 dB

Location: 0, -10.5, 3.7 mm

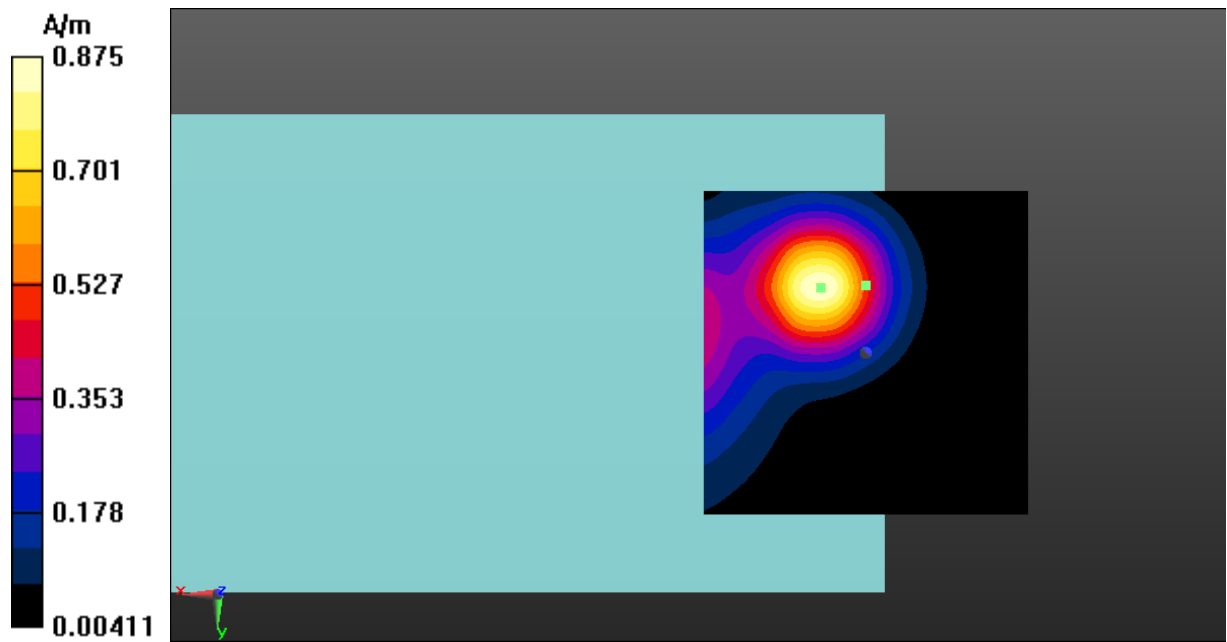

Fig A.1 T-Coil GSM 850-Z



T-Coil GSM 850 Transverse (Ant.1)

Date: 2023-2-8

Electronics: DAE4 Sn786

Medium: Air

Medium parameters used: $\sigma = 0$ S/m, $\epsilon_r = 1$; $\rho = 1$ kg/m³

Communication System: UID 0, GSM (0) Frequency: 836.6 MHz Duty Cycle: 1:8.3

Probe: AM1DV3 - 3086

y (transversal) 4.2mm 50 x 50/ABM Interpolated Signal(x,y,z) (101x101x1): Interpolated grid:

dx=1.000 mm, dy=1.000 mm

Signal Type: Audio File (.wav) 48k_voice_1kHz_1s.wav

Output Gain: 100

Measure Window Start: 300ms

Measure Window Length: 1000ms

BWC applied: 0.15 dB

Device Reference Point: 0, 0, -6.3 mm

Cursor:

ABM1 = -9.85 dBA/m

BWC Factor = 0.15 dB

Location: 8, -18, 3.7 mm

y (transversal) 4.2mm 50 x 50/ABM Interpolated SNR(x,y,z) (101x101x1): Interpolated grid:

dx=1.000 mm, dy=1.000 mm

Signal Type: Audio File (.wav) 48k_voice_1kHz_1s.wav

Output Gain: 100

Measure Window Start: 300ms

Measure Window Length: 1000ms

BWC applied: 0.15 dB

Device Reference Point: 0, 0, -6.3 mm

Cursor:

ABM1/ABM2 = 29.63 dB

ABM1 comp = -12.53 dBA/m

BWC Factor = 0.15 dB

Location: 0.5, 0, 3.7 mm

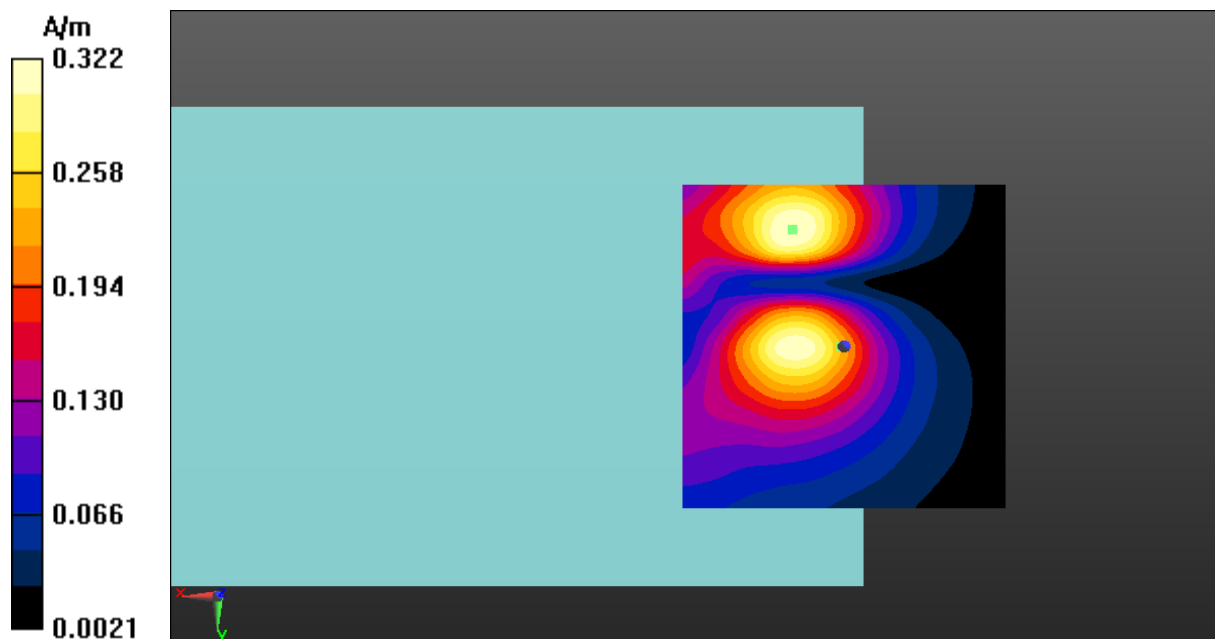

Fig A.1 T-Coil GSM 850-Y



T-Coil GSM 850 Axial (Ant.2)

Date: 2023-2-8

Electronics: DAE4 Sn786

Medium: Air

Medium parameters used: $\sigma = 0$ S/m, $\epsilon_r = 1$; $\rho = 1$ kg/m³

Communication System: UID 0, GSM (0) Frequency: 836.6 MHz Duty Cycle: 1:8.3

Probe: AM1DV3 - 3086

z (axial) 4.2mm 50 x 50/ABM Interpolated Signal(x,y,z) (101x101x1): Interpolated grid:

dx=1.000 mm, dy=1.000 mm

Signal Type: Audio File (.wav) 48k_voice_1kHz_1s.wav

Output Gain: 100

Measure Window Start: 300ms

Measure Window Length: 1000ms

BWC applied: 0.15 dB

Device Reference Point: 0, 0, -6.3 mm

Cursor:

ABM1 = -1.07 dBA/m

BWC Factor = 0.15 dB

Location: 6, -11, 3.7 mm

z (axial) 4.2mm 50 x 50/ABM Interpolated SNR(x,y,z) (101x101x1): Interpolated grid: dx=1.000 mm, dy=1.000 mm

Signal Type: Audio File (.wav) 48k_voice_1kHz_1s.wav

Output Gain: 100

Measure Window Start: 300ms

Measure Window Length: 1000ms

BWC applied: 0.15 dB

Device Reference Point: 0, 0, -6.3 mm

Cursor:

ABM1/ABM2 = 30.65 dB

ABM1 comp = -4.61 dBA/m

BWC Factor = 0.15 dB

Location: 0, -11.5, 3.7 mm

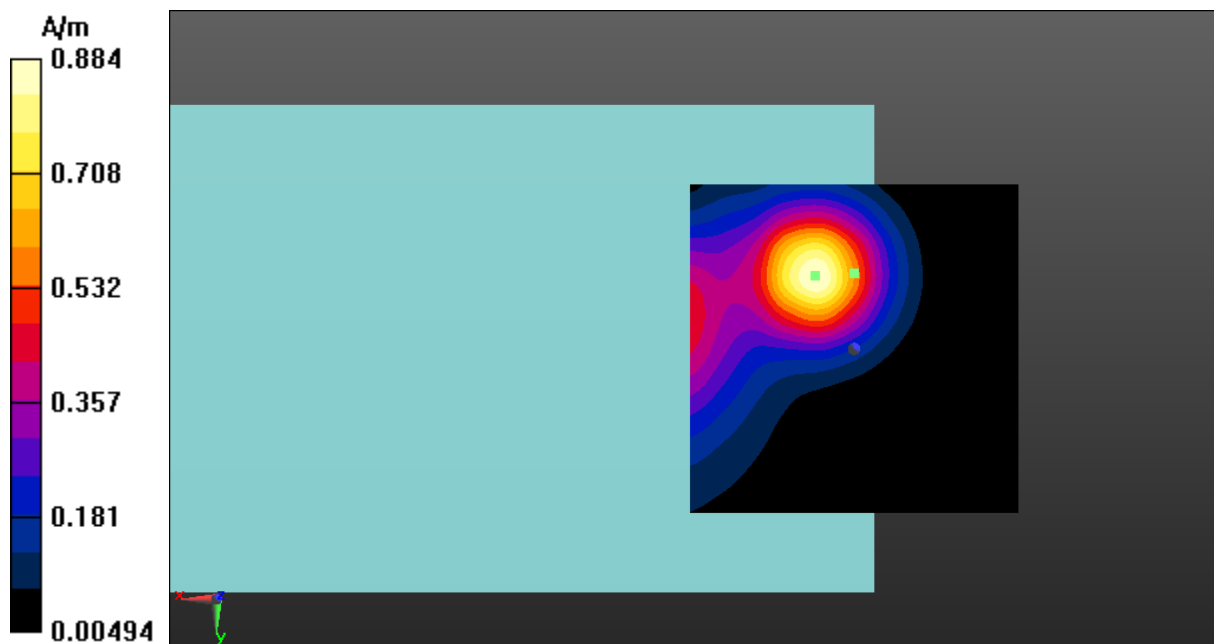

Fig A.2 T-Coil GSM 850-Z



T-Coil GSM 850 Transverse (Ant.2)

Date: 2023-2-8

Electronics: DAE4 Sn786

Medium: Air

Medium parameters used: $\sigma = 0$ S/m, $\epsilon_r = 1$; $\rho = 1$ kg/m³

Communication System: UID 0, GSM (0) Frequency: 836.6 MHz Duty Cycle: 1:8.3

Probe: AM1DV3 - 3086

y (transversal) 4.2mm 50 x 50/ABM Interpolated Signal(x,y,z) (101x101x1): Interpolated grid:

dx=1.000 mm, dy=1.000 mm

Signal Type: Audio File (.wav) 48k_voice_1kHz_1s.wav

Output Gain: 100

Measure Window Start: 300ms

Measure Window Length: 1000ms

BWC applied: 0.15 dB

Device Reference Point: 0, 0, -6.3 mm

Cursor:

ABM1 = -9.79 dBA/m

BWC Factor = 0.15 dB

Location: 6.5, -20, 3.7 mm

y (transversal) 4.2mm 50 x 50/ABM Interpolated SNR(x,y,z) (101x101x1): Interpolated grid:

dx=1.000 mm, dy=1.000 mm

Signal Type: Audio File (.wav) 48k_voice_1kHz_1s.wav

Output Gain: 100

Measure Window Start: 300ms

Measure Window Length: 1000ms

BWC applied: 0.15 dB

Device Reference Point: 0, 0, -6.3 mm

Cursor:

ABM1/ABM2 = 29.36 dB

ABM1 comp = -15.97 dBA/m

BWC Factor = 0.15 dB

Location: -4.5, 0, 3.7 mm

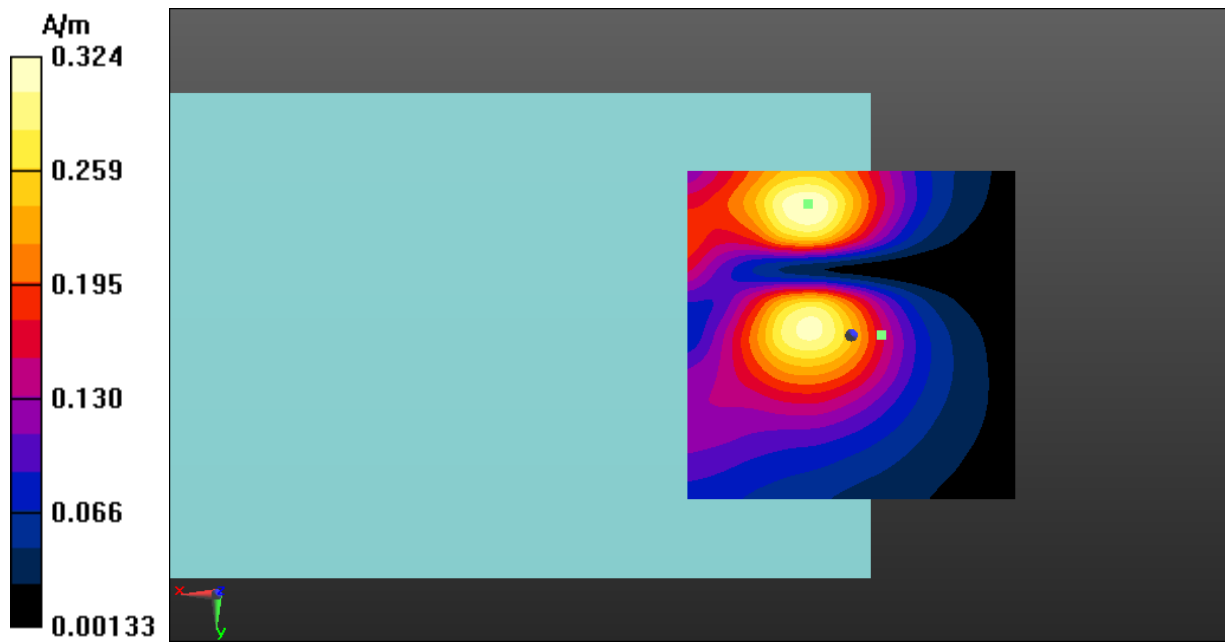

Fig A.2 T-Coil GSM 850-Y



T-Coil GSM 1900 Axial (Ant.0)

Date: 2023-2-8

Electronics: DAE4 Sn786

Medium: Air

Medium parameters used: $\sigma = 0$ S/m, $\epsilon_r = 1$; $\rho = 1$ kg/m³

Communication System: UID 0, GSM (0) Frequency: 1880 MHz Duty Cycle: 1:8.3

Probe: AM1DV3 - 3086

z (axial) 4.2mm 50 x 50/ABM Interpolated Signal(x,y,z) (101x101x1): Interpolated grid:

dx=1.000 mm, dy=1.000 mm

Signal Type: Audio File (.wav) 48k_voice_1kHz_1s.wav

Output Gain: 100

Measure Window Start: 300ms

Measure Window Length: 1000ms

BWC applied: 0.15 dB

Device Reference Point: 0, 0, -6.3 mm

Cursor:

ABM1 = -1.03 dBA/m

BWC Factor = 0.15 dB

Location: 5.5, -11, 3.7 mm

z (axial) 4.2mm 50 x 50/ABM Interpolated SNR(x,y,z) (101x101x1): Interpolated grid: dx=1.000

mm, dy=1.000 mm

Signal Type: Audio File (.wav) 48k_voice_1kHz_1s.wav

Output Gain: 100

Measure Window Start: 300ms

Measure Window Length: 1000ms

BWC applied: 0.15 dB

Device Reference Point: 0, 0, -6.3 mm

Cursor:

ABM1/ABM2 = 34.03 dB

ABM1 comp = -4.44 dBA/m

BWC Factor = 0.15 dB

Location: 0, -11, 3.7 mm

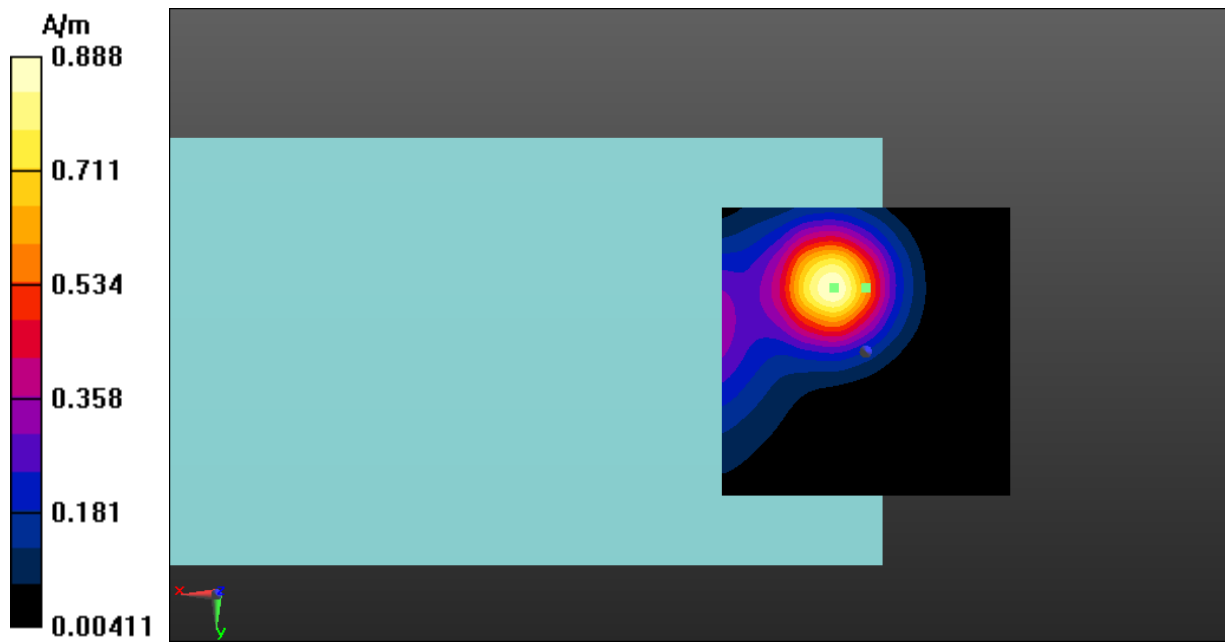

Fig A.3 T-Coil GSM 1900-Z



T-Coil GSM 1900 Transverse (Ant.0)

Date: 2023-2-8

Electronics: DAE4 Sn786

Medium: Air

Medium parameters used: $\sigma = 0$ S/m, $\epsilon_r = 1$; $\rho = 1$ kg/m³

Communication System: UID 0, GSM (0) Frequency: 1880 MHz Duty Cycle: 1:8.3

Probe: AM1DV3 - 3086

y (transversal) 4.2mm 50 x 50/ABM Interpolated Signal(x,y,z) (101x101x1): Interpolated grid:

dx=1.000 mm, dy=1.000 mm

Signal Type: Audio File (.wav) 48k_voice_1kHz_1s.wav

Output Gain: 100

Measure Window Start: 300ms

Measure Window Length: 1000ms

BWC applied: 0.15 dB

Device Reference Point: 0, 0, -6.3 mm

Cursor:

ABM1 = -9.86 dBA/m

BWC Factor = 0.15 dB

Location: 6.5, -20, 3.7 mm

y (transversal) 4.2mm 50 x 50/ABM Interpolated SNR(x,y,z) (101x101x1): Interpolated grid:

dx=1.000 mm, dy=1.000 mm

Signal Type: Audio File (.wav) 48k_voice_1kHz_1s.wav

Output Gain: 100

Measure Window Start: 300ms

Measure Window Length: 1000ms

BWC applied: 0.15 dB

Device Reference Point: 0, 0, -6.3 mm

Cursor:

ABM1/ABM2 = 30.82 dB

ABM1 comp = -14.16 dBA/m

BWC Factor = 0.15 dB

Location: -2.5, 0, 3.7 mm

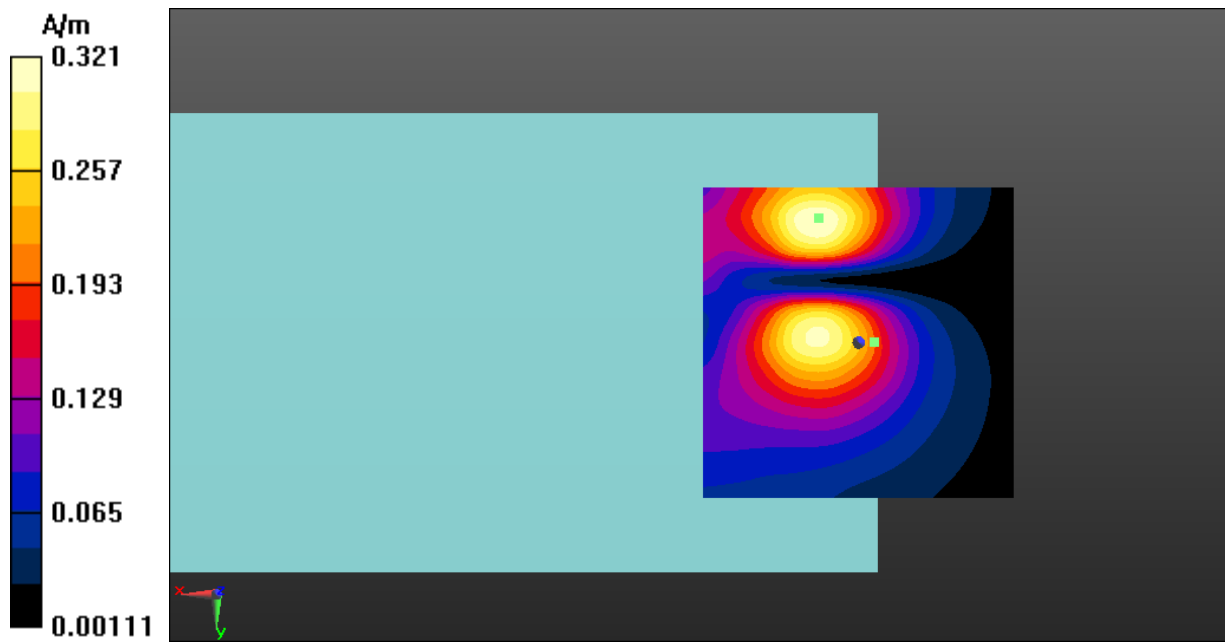

Fig A.3 T-Coil GSM 1900-Y



T-Coil GSM 1900 Axial (Ant.2)

Date: 2023-2-8

Electronics: DAE4 Sn786

Medium: Air

Medium parameters used: $\sigma = 0$ S/m, $\epsilon_r = 1$; $\rho = 1$ kg/m³

Communication System: UID 0, GSM (0) Frequency: 1880 MHz Duty Cycle: 1:8.3

Probe: AM1DV3 - 3086

z (axial) 4.2mm 50 x 50/ABM Interpolated Signal(x,y,z) (101x101x1): Interpolated grid:

dx=1.000 mm, dy=1.000 mm

Signal Type: Audio File (.wav) 48k_voice_1kHz_1s.wav

Output Gain: 100

Measure Window Start: 300ms

Measure Window Length: 1000ms

BWC applied: 0.15 dB

Device Reference Point: 0, 0, -6.3 mm

Cursor:

ABM1 = -1.03 dBA/m

BWC Factor = 0.15 dB

Location: 7.5, -10.5, 3.7 mm

z (axial) 4.2mm 50 x 50/ABM Interpolated SNR(x,y,z) (101x101x1): Interpolated grid: dx=1.000

mm, dy=1.000 mm

Signal Type: Audio File (.wav) 48k_voice_1kHz_1s.wav

Output Gain: 100

Measure Window Start: 300ms

Measure Window Length: 1000ms

BWC applied: 0.15 dB

Device Reference Point: 0, 0, -6.3 mm

Cursor:

ABM1/ABM2 = 33.12 dB

ABM1 comp = -6.22 dBA/m

BWC Factor = 0.15 dB

Location: 0, -11.5, 3.7 mm

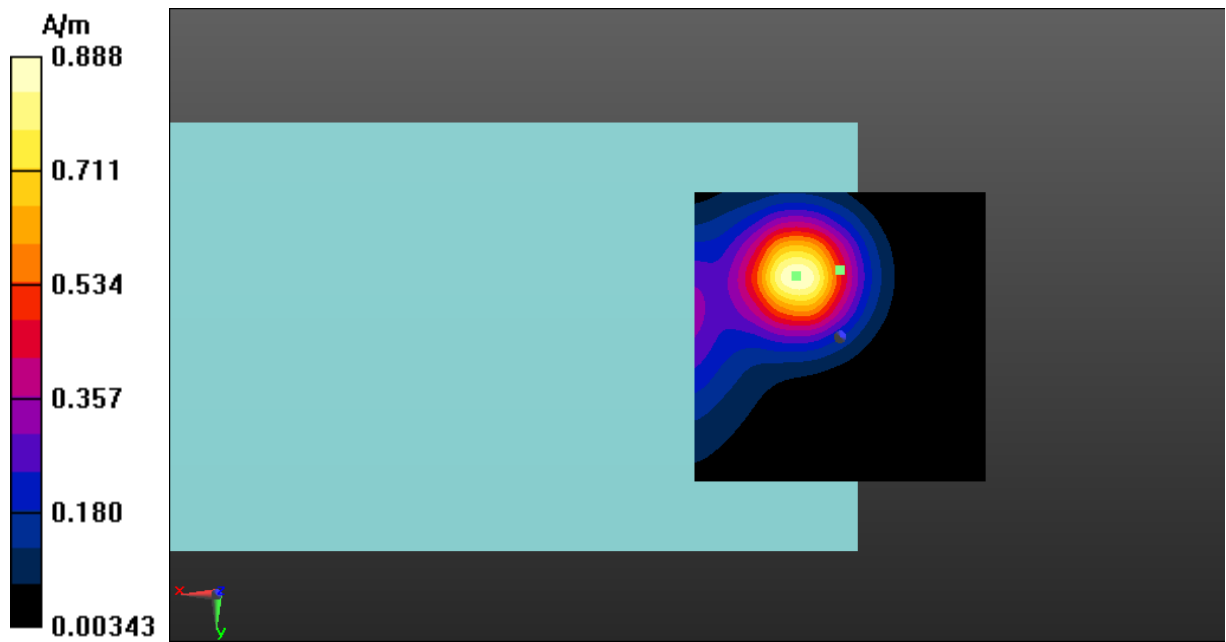

Fig A.4 T-Coil GSM 1900-Z



T-Coil GSM 1900 Transverse (Ant.2)

Date: 2023-2-8

Electronics: DAE4 Sn786

Medium: Air

Medium parameters used: $\sigma = 0$ S/m, $\epsilon_r = 1$; $\rho = 1$ kg/m³

Communication System: UID 0, GSM (0) Frequency: 1880 MHz Duty Cycle: 1:8.3

Probe: AM1DV3 - 3086

y (transversal) 4.2mm 50 x 50/ABM Interpolated Signal(x,y,z) (101x101x1): Interpolated grid:

dx=1.000 mm, dy=1.000 mm

Signal Type: Audio File (.wav) 48k_voice_1kHz_1s.wav

Output Gain: 100

Measure Window Start: 300ms

Measure Window Length: 1000ms

BWC applied: 0.15 dB

Device Reference Point: 0, 0, -6.3 mm

Cursor:

ABM1 = -9.96 dBA/m

BWC Factor = 0.15 dB

Location: 8.5, -18.5, 3.7 mm

y (transversal) 4.2mm 50 x 50/ABM Interpolated SNR(x,y,z) (101x101x1): Interpolated grid:

dx=1.000 mm, dy=1.000 mm

Signal Type: Audio File (.wav) 48k_voice_1kHz_1s.wav

Output Gain: 100

Measure Window Start: 300ms

Measure Window Length: 1000ms

BWC applied: 0.15 dB

Device Reference Point: 0, 0, -6.3 mm

Cursor:

ABM1/ABM2 = 31.39 dB

ABM1 comp = -13.08 dBA/m

BWC Factor = 0.15 dB

Location: 0, 0, 3.7 mm

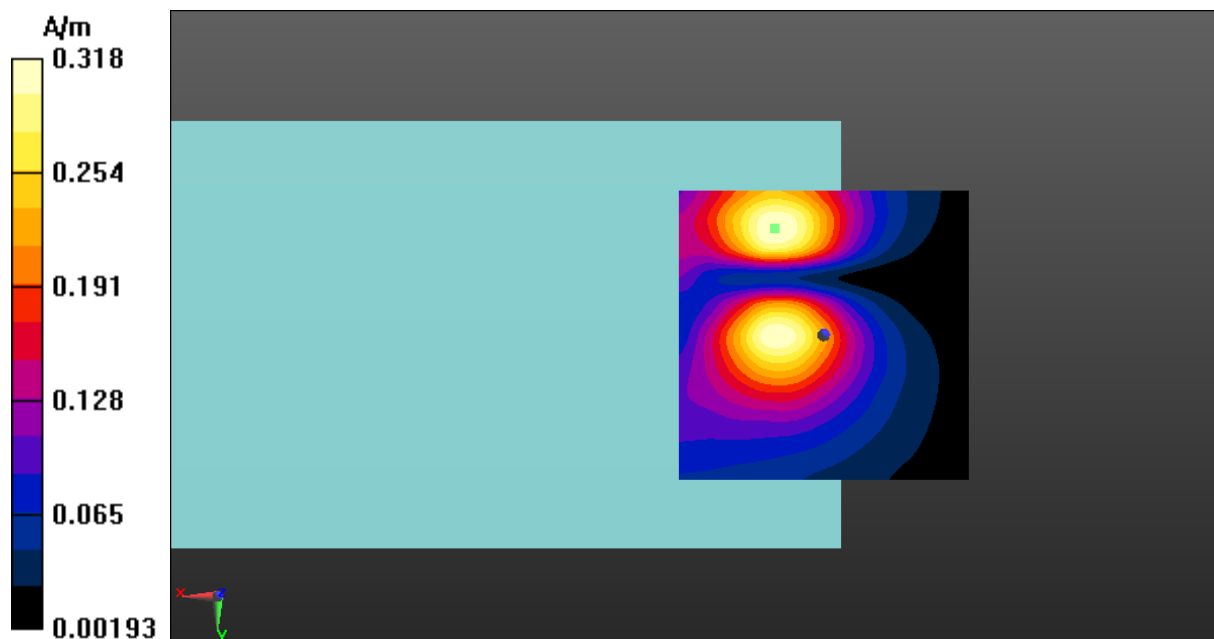

Fig A.4 T-Coil GSM 1900-Y



T-Coil WCDMA Band 2 Axial (Ant.0)

Date: 2023-2-8

Electronics: DAE4 Sn786

Medium: Air

Medium parameters used: $\sigma = 0$ S/m, $\epsilon_r = 1$; $\rho = 1$ kg/m³

Communication System: UID 0, WCDMA (0) Frequency: 1880 MHz Duty Cycle: 1:1

Probe: AM1DV3 - 3086

z (axial) 4.2mm 50 x 50/ABM Interpolated Signal(x,y,z) (101x101x1): Interpolated grid:

dx=1.000 mm, dy=1.000 mm

Signal Type: Audio File (.wav) 48k_voice_1kHz_1s.wav

Output Gain: 100

Measure Window Start: 300ms

Measure Window Length: 1000ms

BWC applied: 0.16 dB

Device Reference Point: 0, 0, -6.3 mm

Cursor:

ABM1 = -1.17 dBA/m

BWC Factor = 0.16 dB

Location: 7.5, -10.5, 3.7 mm

z (axial) 4.2mm 50 x 50/ABM Interpolated SNR(x,y,z) (101x101x1): Interpolated grid: dx=1.000 mm, dy=1.000 mm

Signal Type: Audio File (.wav) 48k_voice_1kHz_1s.wav

Output Gain: 100

Measure Window Start: 300ms

Measure Window Length: 1000ms

BWC applied: 0.16 dB

Device Reference Point: 0, 0, -6.3 mm

Cursor:

ABM1/ABM2 = 50.12 dB

ABM1 comp = -1.64 dBA/m

BWC Factor = 0.16 dB

Location: 5, -10.5, 3.7 mm

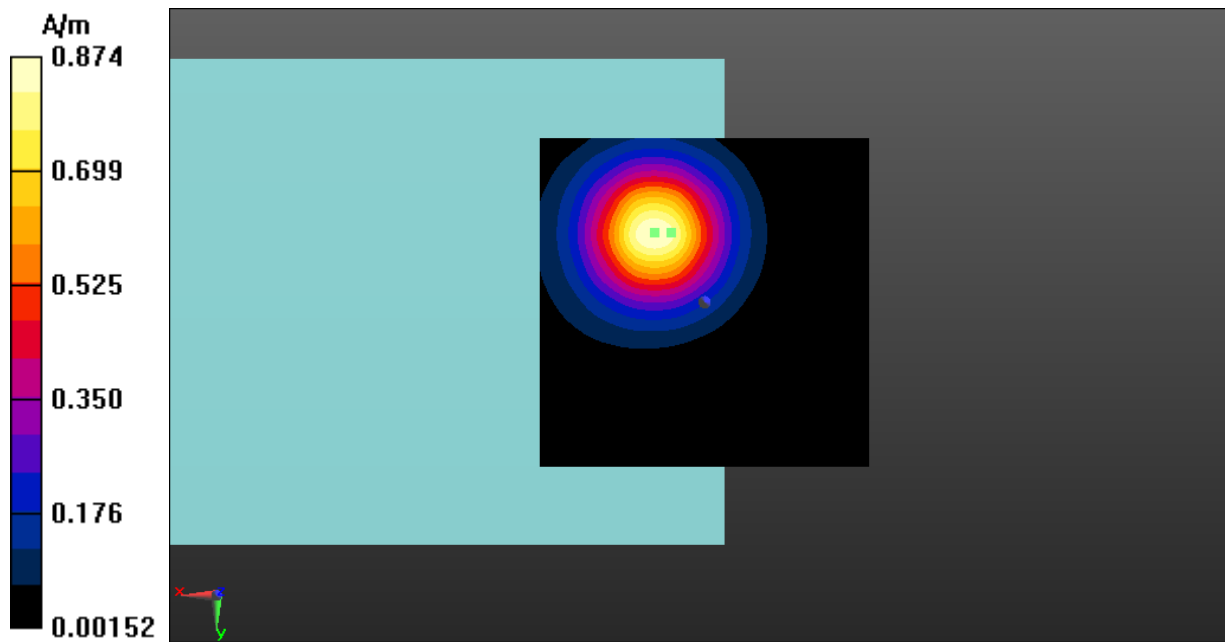

Fig A.5 T-Coil WCDMA Band 2-Z



T-Coil WCDMA Band 2 Transverse (Ant.0)

Date: 2023-2-8

Electronics: DAE4 Sn786

Medium: Air

Medium parameters used: $\sigma = 0$ S/m, $\epsilon_r = 1$; $\rho = 1$ kg/m³

Communication System: UID 0, WCDMA (0) Frequency: 1880 MHz Duty Cycle: 1:1

Probe: AM1DV3 - 3086

y (transversal) 4.2mm 50 x 50/ABM Interpolated Signal(x,y,z) (101x101x1): Interpolated grid:

dx=1.000 mm, dy=1.000 mm

Signal Type: Audio File (.wav) 48k_voice_1kHz_1s.wav

Output Gain: 100

Measure Window Start: 300ms

Measure Window Length: 1000ms

BWC applied: 0.16 dB

Device Reference Point: 0, 0, -6.3 mm

Cursor:

ABM1 = -10.92 dBA/m

BWC Factor = 0.16 dB

Location: 4.5, -21, 3.7 mm

y (transversal) 4.2mm 50 x 50/ABM Interpolated SNR(x,y,z) (101x101x1): Interpolated grid:

dx=1.000 mm, dy=1.000 mm

Signal Type: Audio File (.wav) 48k_voice_1kHz_1s.wav

Output Gain: 100

Measure Window Start: 300ms

Measure Window Length: 1000ms

BWC applied: 0.16 dB

Device Reference Point: 0, 0, -6.3 mm

Cursor:

ABM1/ABM2 = 40.15 dB

ABM1 comp = -11.23 dBA/m

BWC Factor = 0.16 dB

Location: 2.5, -22, 3.7 mm

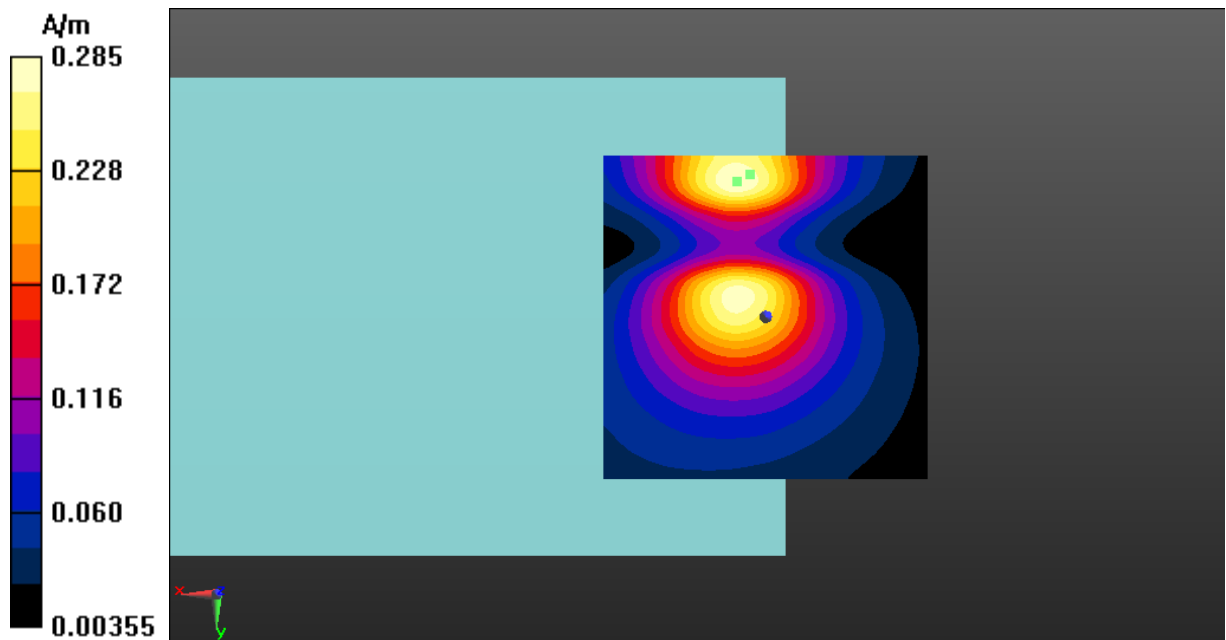

Fig A.5 T-Coil WCDMA Band 2-Y



T-Coil WCDMA Band 2 Axial (Ant.2)

Date: 2023-2-8

Electronics: DAE4 Sn786

Medium: Air

Medium parameters used: $\sigma = 0$ S/m, $\epsilon_r = 1$; $\rho = 1$ kg/m³

Communication System: UID 0, WCDMA (0) Frequency: 1880 MHz Duty Cycle: 1:1

Probe: AM1DV3 - 3086

z (axial) 4.2mm 50 x 50/ABM Interpolated Signal(x,y,z) (101x101x1): Interpolated grid:

dx=1.000 mm, dy=1.000 mm

Signal Type: Audio File (.wav) 48k_voice_1kHz_1s.wav

Output Gain: 100

Measure Window Start: 300ms

Measure Window Length: 1000ms

BWC applied: 0.16 dB

Device Reference Point: 0, 0, -6.3 mm

Cursor:

ABM1 = -1.32 dBA/m

BWC Factor = 0.16 dB

Location: 7.5, -10, 3.7 mm

z (axial) 4.2mm 50 x 50/ABM Interpolated SNR(x,y,z) (101x101x1): Interpolated grid: dx=1.000

mm, dy=1.000 mm

Signal Type: Audio File (.wav) 48k_voice_1kHz_1s.wav

Output Gain: 100

Measure Window Start: 300ms

Measure Window Length: 1000ms

BWC applied: 0.16 dB

Device Reference Point: 0, 0, -6.3 mm

Cursor:

ABM1/ABM2 = 50.02 dB

ABM1 comp = -1.69 dBA/m

BWC Factor = 0.16 dB

Location: 5, -10, 3.7 mm

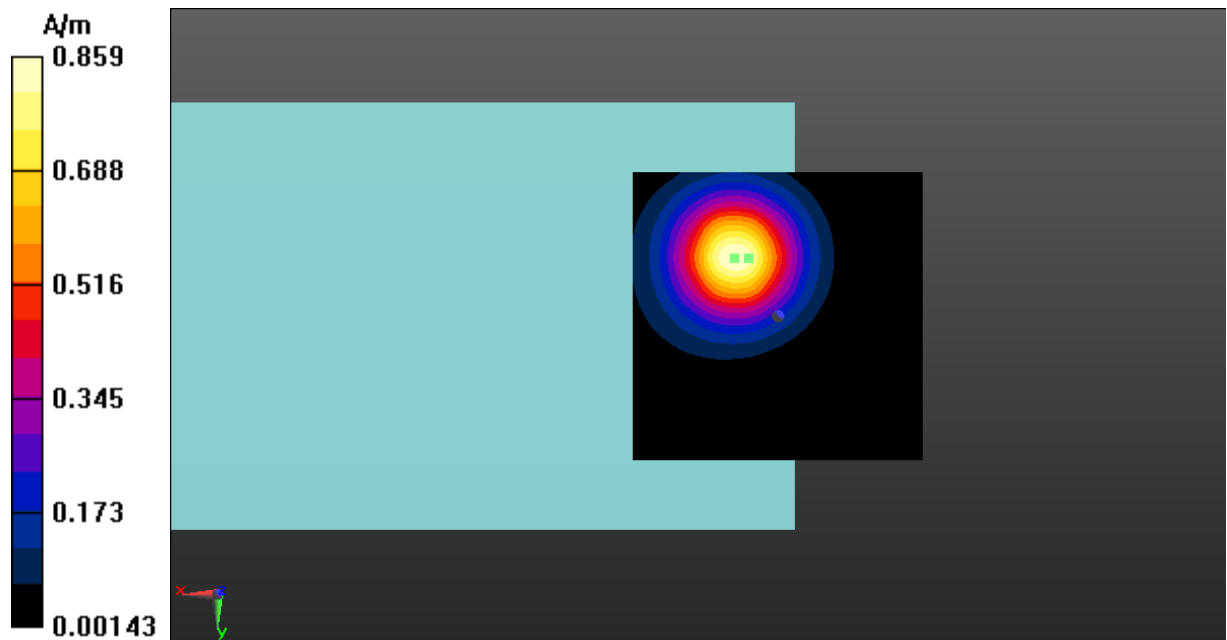

Fig A.6 T-Coil WCDMA Band 2-Z



T-Coil WCDMA Band 2 Transverse (Ant.2)

Date: 2023-2-8

Electronics: DAE4 Sn786

Medium: Air

Medium parameters used: $\sigma = 0$ S/m, $\epsilon_r = 1$; $\rho = 1$ kg/m³

Communication System: UID 0, WCDMA (0) Frequency: 1880 MHz Duty Cycle: 1:1

Probe: AM1DV3 - 3086

y (transversal) 4.2mm 50 x 50/ABM Interpolated Signal(x,y,z) (101x101x1): Interpolated grid:

dx=1.000 mm, dy=1.000 mm

Signal Type: Audio File (.wav) 48k_voice_1kHz_1s.wav

Output Gain: 100

Measure Window Start: 300ms

Measure Window Length: 1000ms

BWC applied: 0.16 dB

Device Reference Point: 0, 0, -6.3 mm

Cursor:

ABM1 = -11.03 dBA/m

BWC Factor = 0.16 dB

Location: 4.5, -21, 3.7 mm

y (transversal) 4.2mm 50 x 50/ABM Interpolated SNR(x,y,z) (101x101x1): Interpolated grid:

dx=1.000 mm, dy=1.000 mm

Signal Type: Audio File (.wav) 48k_voice_1kHz_1s.wav

Output Gain: 100

Measure Window Start: 300ms

Measure Window Length: 1000ms

BWC applied: 0.16 dB

Device Reference Point: 0, 0, -6.3 mm

Cursor:

ABM1/ABM2 = 39.98 dB

ABM1 comp = -11.38 dBA/m

BWC Factor = 0.16 dB

Location: 2, -21.5, 3.7 mm

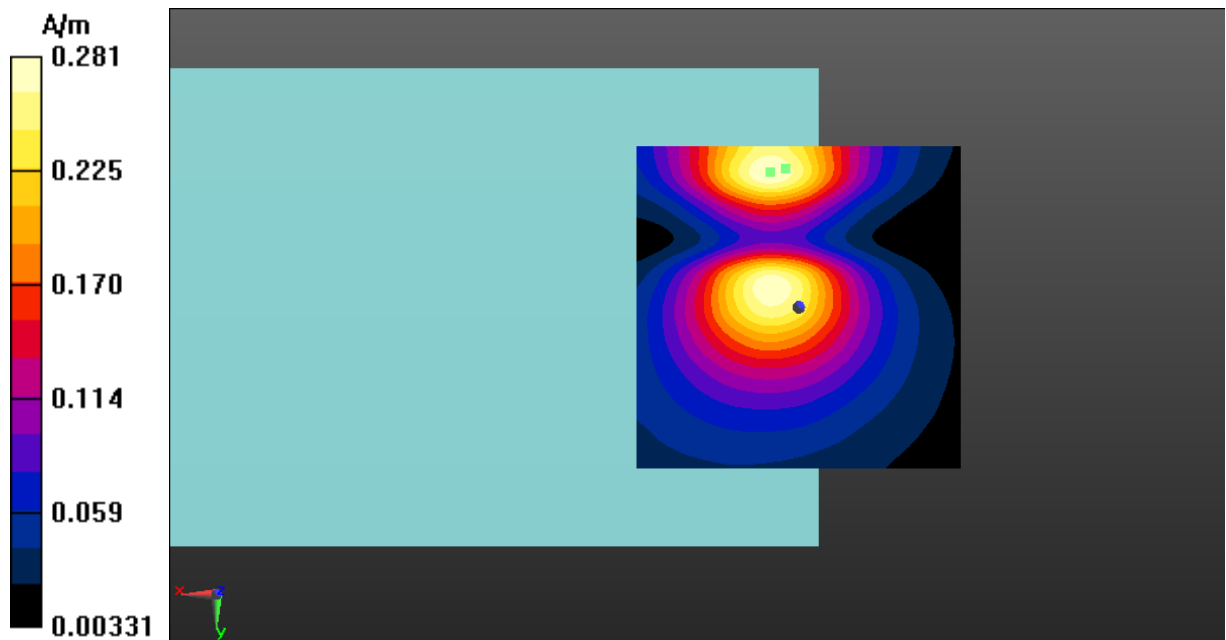

Fig A.6 T-Coil WCDMA Band 2-Y



T-Coil WCDMA Band 4 Axial (Ant.0)

Date: 2023-2-8

Electronics: DAE4 Sn786

Medium: Air

Medium parameters used: $\sigma = 0$ S/m, $\epsilon_r = 1$; $\rho = 1$ kg/m³

Communication System: UID 0, WCDMA (0) Frequency: 1732.6 MHz Duty Cycle: 1:1

Probe: AM1DV3 - 3086

z (axial) 4.2mm 50 x 50/ABM Interpolated Signal(x,y,z) (101x101x1): Interpolated grid:

dx=1.000 mm, dy=1.000 mm

Signal Type: Audio File (.wav) 48k_voice_1kHz_1s.wav

Output Gain: 100

Measure Window Start: 300ms

Measure Window Length: 1000ms

BWC applied: 0.16 dB

Device Reference Point: 0, 0, -6.3 mm

Cursor:

ABM1 = -1.20 dBA/m

BWC Factor = 0.16 dB

Location: 7.5, -10.5, 3.7 mm

z (axial) 4.2mm 50 x 50/ABM Interpolated SNR(x,y,z) (101x101x1): Interpolated grid: dx=1.000 mm, dy=1.000 mm

Signal Type: Audio File (.wav) 48k_voice_1kHz_1s.wav

Output Gain: 100

Measure Window Start: 300ms

Measure Window Length: 1000ms

BWC applied: 0.16 dB

Device Reference Point: 0, 0, -6.3 mm

Cursor:

ABM1/ABM2 = 49.80 dB

ABM1 comp = -1.72 dBA/m

BWC Factor = 0.16 dB

Location: 5, -11, 3.7 mm

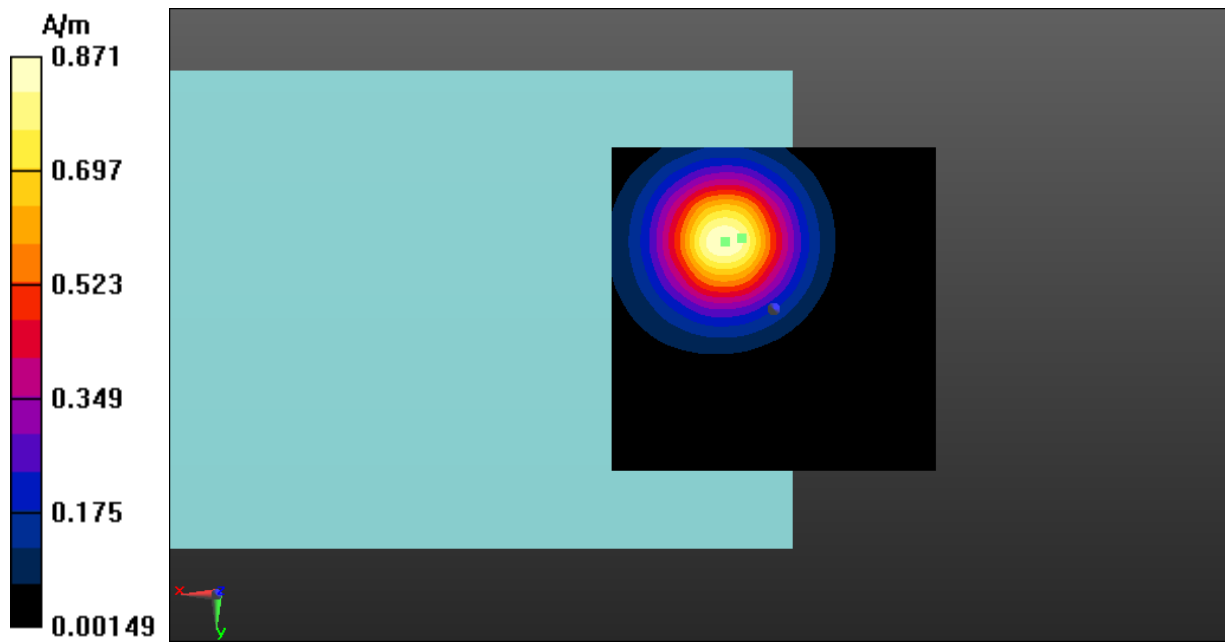

Fig A.7 T-Coil WCDMA Band 4-Z



T-Coil WCDMA Band 4 Transverse (Ant.0)

Date: 2023-2-8

Electronics: DAE4 Sn786

Medium: Air

Medium parameters used: $\sigma = 0$ S/m, $\epsilon_r = 1$; $\rho = 1$ kg/m³

Communication System: UID 0, WCDMA (0) Frequency: 1732.6 MHz Duty Cycle: 1:1

Probe: AM1DV3 - 3086

y (transversal) 4.2mm 50 x 50/ABM Interpolated Signal(x,y,z) (101x101x1): Interpolated grid:

dx=1.000 mm, dy=1.000 mm

Signal Type: Audio File (.wav) 48k_voice_1kHz_1s.wav

Output Gain: 100

Measure Window Start: 300ms

Measure Window Length: 1000ms

BWC applied: 0.16 dB

Device Reference Point: 0, 0, -6.3 mm

Cursor:

ABM1 = -10.92 dBA/m

BWC Factor = 0.16 dB

Location: 4.5, -21, 3.7 mm

y (transversal) 4.2mm 50 x 50/ABM Interpolated SNR(x,y,z) (101x101x1): Interpolated grid:

dx=1.000 mm, dy=1.000 mm

Signal Type: Audio File (.wav) 48k_voice_1kHz_1s.wav

Output Gain: 100

Measure Window Start: 300ms

Measure Window Length: 1000ms

BWC applied: 0.16 dB

Device Reference Point: 0, 0, -6.3 mm

Cursor:

ABM1/ABM2 = 39.76 dB

ABM1 comp = -11.70 dBA/m

BWC Factor = 0.16 dB

Location: 0.5, -3.5, 3.7 mm

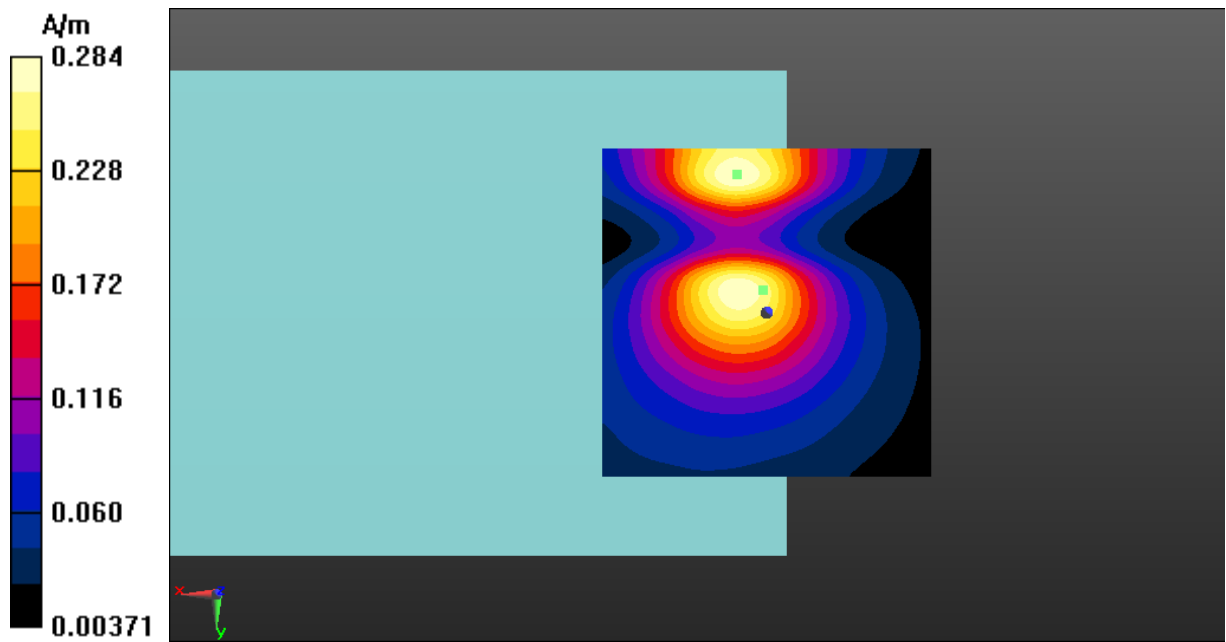

Fig A.7 T-Coil WCDMA Band 4-Y



T-Coil WCDMA Band 4 Axial (Ant.2)

Date: 2023-2-8

Electronics: DAE4 Sn786

Medium: Air

Medium parameters used: $\sigma = 0$ S/m, $\epsilon_r = 1$; $\rho = 1$ kg/m³

Communication System: UID 0, WCDMA (0) Frequency: 1732.6 MHz Duty Cycle: 1:1

Probe: AM1DV3 - 3086

z (axial) 4.2mm 50 x 50/ABM Interpolated Signal(x,y,z) (101x101x1): Interpolated grid:

dx=1.000 mm, dy=1.000 mm

Signal Type: Audio File (.wav) 48k_voice_1kHz_1s.wav

Output Gain: 100

Measure Window Start: 300ms

Measure Window Length: 1000ms

BWC applied: 0.16 dB

Device Reference Point: 0, 0, -6.3 mm

Cursor:

ABM1 = -1.18 dBA/m

BWC Factor = 0.16 dB

Location: 7.5, -10, 3.7 mm

z (axial) 4.2mm 50 x 50/ABM Interpolated SNR(x,y,z) (101x101x1): Interpolated grid: dx=1.000

mm, dy=1.000 mm

Signal Type: Audio File (.wav) 48k_voice_1kHz_1s.wav

Output Gain: 100

Measure Window Start: 300ms

Measure Window Length: 1000ms

BWC applied: 0.16 dB

Device Reference Point: 0, 0, -6.3 mm

Cursor:

ABM1/ABM2 = 49.91 dB

ABM1 comp = -1.57 dBA/m

BWC Factor = 0.16 dB

Location: 5, -10, 3.7 mm

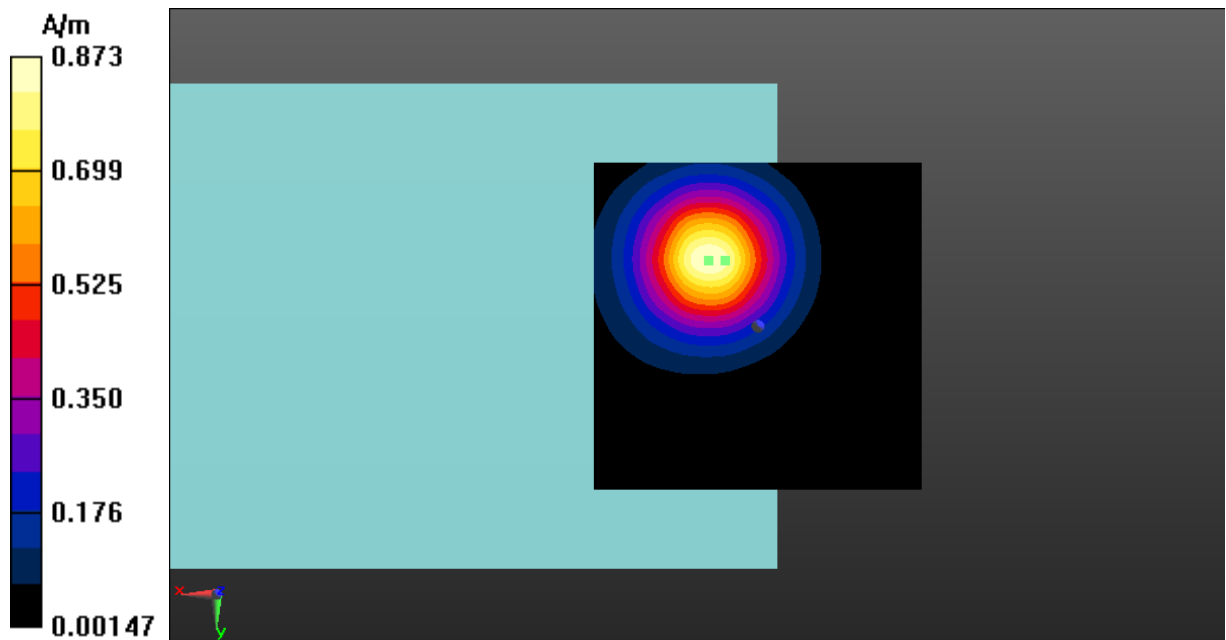

Fig A.8 T-Coil WCDMA Band 4-Z



T-Coil WCDMA Band 4 Transverse (Ant.2)

Date: 2023-2-8

Electronics: DAE4 Sn786

Medium: Air

Medium parameters used: $\sigma = 0$ S/m, $\epsilon_r = 1$; $\rho = 1$ kg/m³

Communication System: UID 0, WCDMA (0) Frequency: 1732.6 MHz Duty Cycle: 1:1

Probe: AM1DV3 - 3086

y (transversal) 4.2mm 50 x 50/ABM Interpolated Signal(x,y,z) (101x101x1): Interpolated grid:

dx=1.000 mm, dy=1.000 mm

Signal Type: Audio File (.wav) 48k_voice_1kHz_1s.wav

Output Gain: 100

Measure Window Start: 300ms

Measure Window Length: 1000ms

BWC applied: 0.16 dB

Device Reference Point: 0, 0, -6.3 mm

Cursor:

ABM1 = -10.96 dBA/m

BWC Factor = 0.16 dB

Location: 4.5, -21, 3.7 mm

y (transversal) 4.2mm 50 x 50/ABM Interpolated SNR(x,y,z) (101x101x1): Interpolated grid:

dx=1.000 mm, dy=1.000 mm

Signal Type: Audio File (.wav) 48k_voice_1kHz_1s.wav

Output Gain: 100

Measure Window Start: 300ms

Measure Window Length: 1000ms

BWC applied: 0.16 dB

Device Reference Point: 0, 0, -6.3 mm

Cursor:

ABM1/ABM2 = 40.09 dB

ABM1 comp = -11.98 dBA/m

BWC Factor = 0.16 dB

Location: 1, -0.5, 3.7 mm

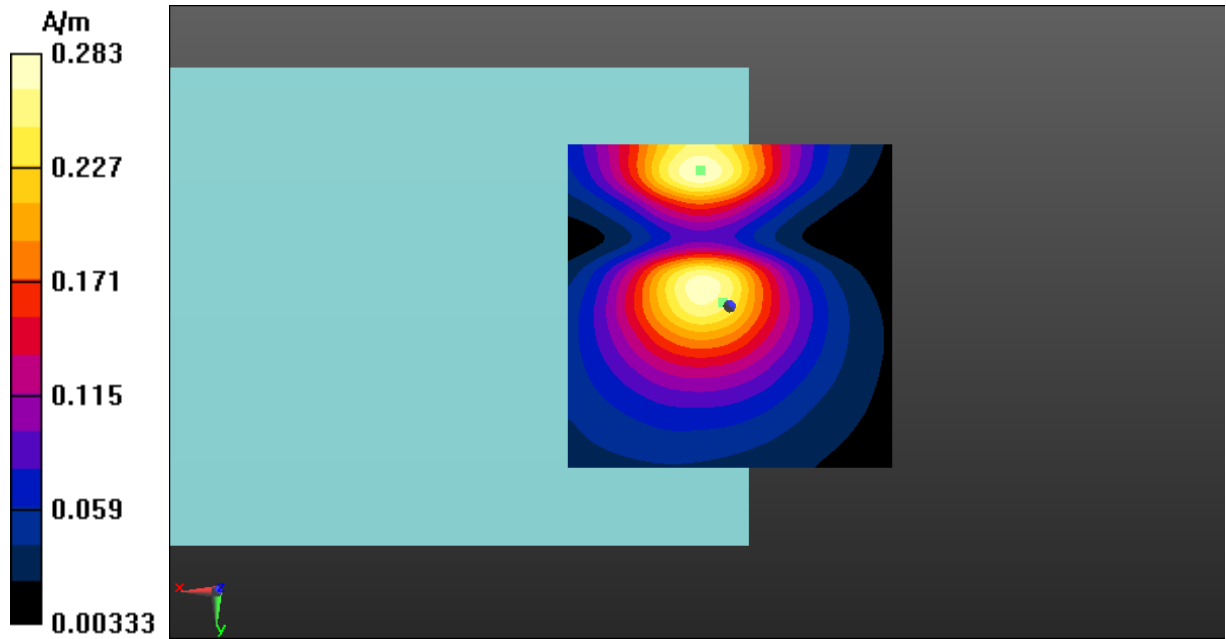

Fig A.8 T-Coil WCDMA Band 4-Y



T-Coil WCDMA Band 5 Axial (Ant.1)

Date: 2023-2-8

Electronics: DAE4 Sn786

Medium: Air

Medium parameters used: $\sigma = 0$ S/m, $\epsilon_r = 1$; $\rho = 1$ kg/m³

Communication System: UID 0, WCDMA (0) Frequency: 836.4 MHz Duty Cycle: 1:1

Probe: AM1DV3 - 3086

z (axial) 4.2mm 50 x 50/ABM Interpolated Signal(x,y,z) (101x101x1): Interpolated grid:

dx=1.000 mm, dy=1.000 mm

Signal Type: Audio File (.wav) 48k_voice_1kHz_1s.wav

Output Gain: 100

Measure Window Start: 300ms

Measure Window Length: 1000ms

BWC applied: 0.16 dB

Device Reference Point: 0, 0, -6.3 mm

Cursor:

ABM1 = -1.17 dBA/m

BWC Factor = 0.16 dB

Location: 7.5, -10, 3.7 mm

z (axial) 4.2mm 50 x 50/ABM Interpolated SNR(x,y,z) (101x101x1): Interpolated grid: dx=1.000

mm, dy=1.000 mm

Signal Type: Audio File (.wav) 48k_voice_1kHz_1s.wav

Output Gain: 100

Measure Window Start: 300ms

Measure Window Length: 1000ms

BWC applied: 0.16 dB

Device Reference Point: 0, 0, -6.3 mm

Cursor:

ABM1/ABM2 = 49.64 dB

ABM1 comp = -1.55 dBA/m

BWC Factor = 0.16 dB

Location: 5, -10.5, 3.7 mm

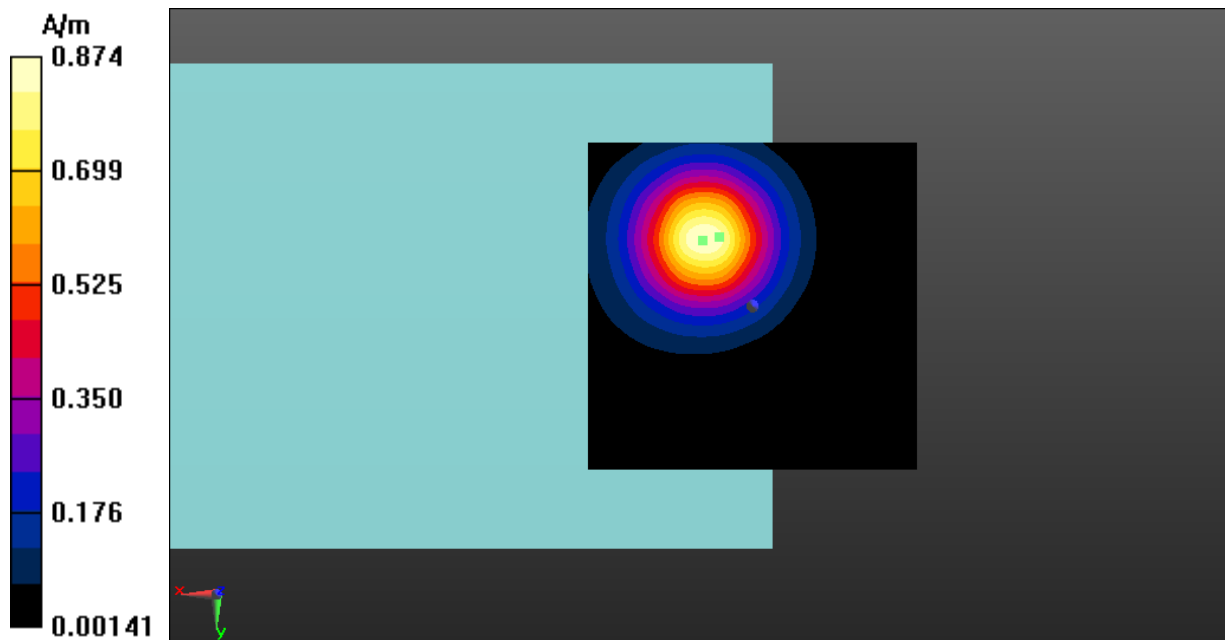

Fig A.9 T-Coil WCDMA Band 5-Z



T-Coil WCDMA Band 5 Transverse (Ant.1)

Date: 2023-2-8

Electronics: DAE4 Sn786

Medium: Air

Medium parameters used: $\sigma = 0$ S/m, $\epsilon_r = 1$; $\rho = 1$ kg/m³

Communication System: UID 0, WCDMA (0) Frequency: 836.4 MHz Duty Cycle: 1:1

Probe: AM1DV3 - 3086

y (transversal) 4.2mm 50 x 50/ABM Interpolated Signal(x,y,z) (101x101x1): Interpolated grid:

dx=1.000 mm, dy=1.000 mm

Signal Type: Audio File (.wav) 48k_voice_1kHz_1s.wav

Output Gain: 100

Measure Window Start: 300ms

Measure Window Length: 1000ms

BWC applied: 0.16 dB

Device Reference Point: 0, 0, -6.3 mm

Cursor:

ABM1 = -10.95 dBA/m

BWC Factor = 0.16 dB

Location: 4.5, -21, 3.7 mm

y (transversal) 4.2mm 50 x 50/ABM Interpolated SNR(x,y,z) (101x101x1): Interpolated grid:

dx=1.000 mm, dy=1.000 mm

Signal Type: Audio File (.wav) 48k_voice_1kHz_1s.wav

Output Gain: 100

Measure Window Start: 300ms

Measure Window Length: 1000ms

BWC applied: 0.16 dB

Device Reference Point: 0, 0, -6.3 mm

Cursor:

ABM1/ABM2 = 39.67 dB

ABM1 comp = -11.97 dBA/m

BWC Factor = 0.16 dB

Location: 0, -21.5, 3.7 mm

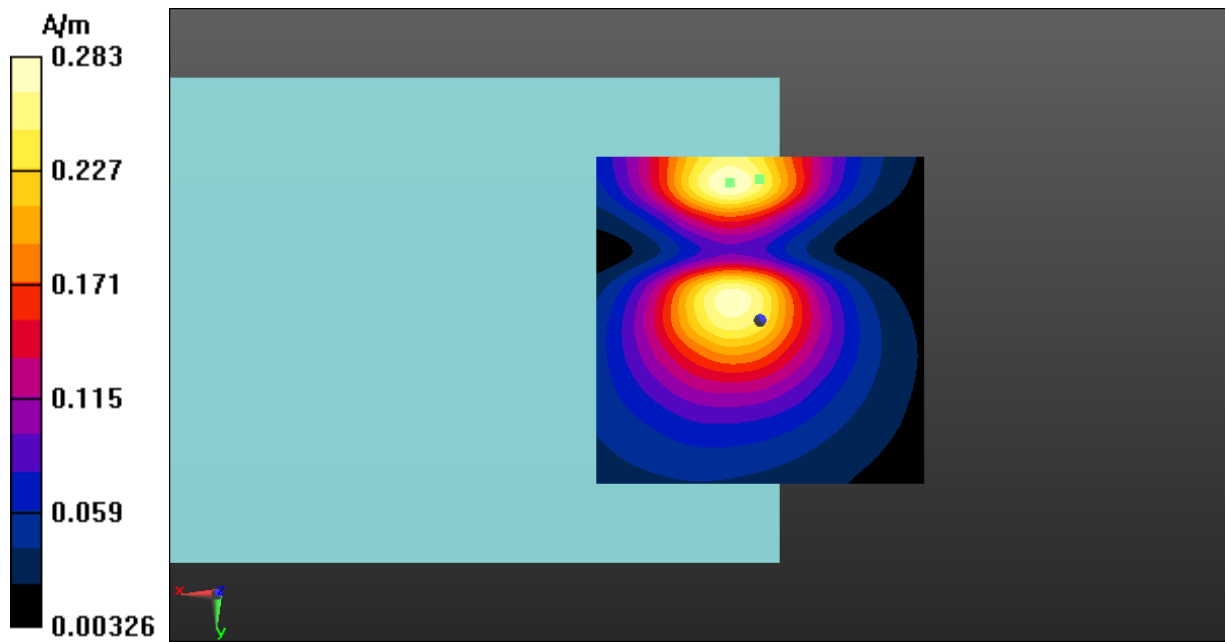

Fig A.9 T-Coil WCDMA Band 5-Y



T-Coil WCDMA Band 5 Axial (Ant.2)

Date: 2023-2-8

Electronics: DAE4 Sn786

Medium: Air

Medium parameters used: $\sigma = 0$ S/m, $\epsilon_r = 1$; $\rho = 1$ kg/m³

Communication System: UID 0, WCDMA (0) Frequency: 836.4 MHz Duty Cycle: 1:1

Probe: AM1DV3 - 3086

z (axial) 4.2mm 50 x 50/ABM Interpolated Signal(x,y,z) (101x101x1): Interpolated grid:

dx=1.000 mm, dy=1.000 mm

Signal Type: Audio File (.wav) 48k_voice_1kHz_1s.wav

Output Gain: 100

Measure Window Start: 300ms

Measure Window Length: 1000ms

BWC applied: 0.16 dB

Device Reference Point: 0, 0, -6.3 mm

Cursor:

ABM1 = -1.23 dBA/m

BWC Factor = 0.16 dB

Location: 7.5, -10.5, 3.7 mm

z (axial) 4.2mm 50 x 50/ABM Interpolated SNR(x,y,z) (101x101x1): Interpolated grid: dx=1.000 mm, dy=1.000 mm

Signal Type: Audio File (.wav) 48k_voice_1kHz_1s.wav

Output Gain: 100

Measure Window Start: 300ms

Measure Window Length: 1000ms

BWC applied: 0.16 dB

Device Reference Point: 0, 0, -6.3 mm

Cursor:

ABM1/ABM2 = 50.05 dB

ABM1 comp = -1.63 dBA/m

BWC Factor = 0.16 dB

Location: 5, -10.5, 3.7 mm

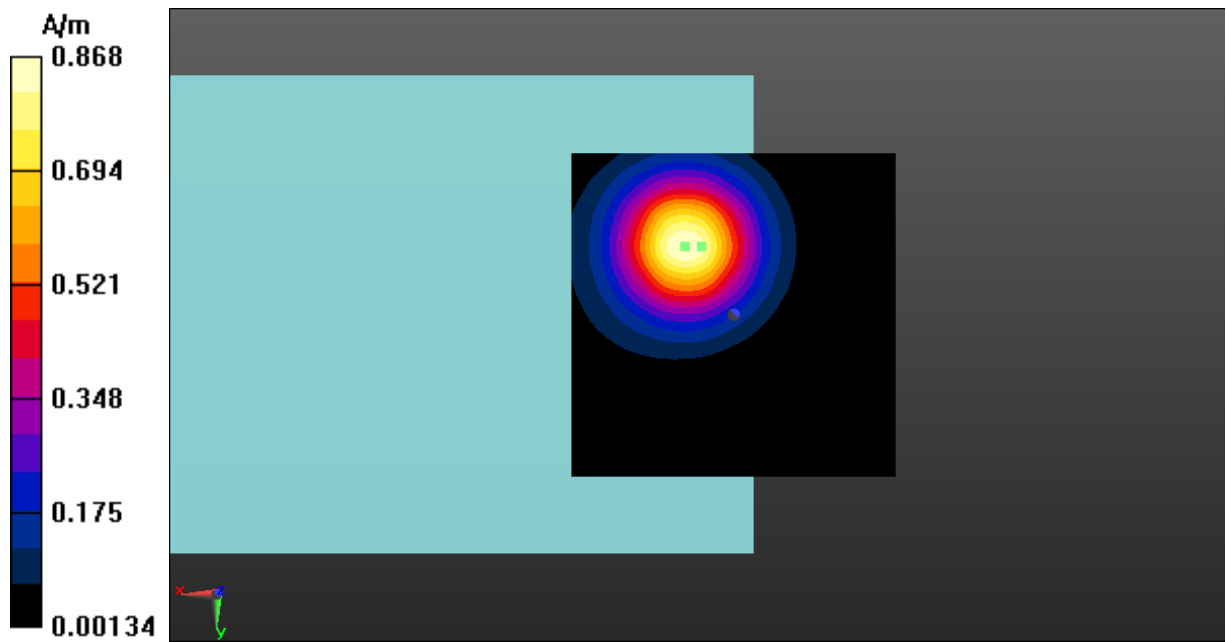

Fig A.10 T-Coil WCDMA Band 5-Z



T-Coil WCDMA Band 5 Transverse (Ant.2)

Date: 2023-2-8

Electronics: DAE4 Sn786

Medium: Air

Medium parameters used: $\sigma = 0$ S/m, $\epsilon_r = 1$; $\rho = 1$ kg/m³

Communication System: UID 0, WCDMA (0) Frequency: 836.4 MHz Duty Cycle: 1:1

Probe: AM1DV3 - 3086

y (transversal) 4.2mm 50 x 50/ABM Interpolated Signal(x,y,z) (101x101x1): Interpolated grid:

dx=1.000 mm, dy=1.000 mm

Signal Type: Audio File (.wav) 48k_voice_1kHz_1s.wav

Output Gain: 100

Measure Window Start: 300ms

Measure Window Length: 1000ms

BWC applied: 0.16 dB

Device Reference Point: 0, 0, -6.3 mm

Cursor:

ABM1 = -10.97 dBA/m

BWC Factor = 0.16 dB

Location: 4.5, -3.5, 3.7 mm

y (transversal) 4.2mm 50 x 50/ABM Interpolated SNR(x,y,z) (101x101x1): Interpolated grid:

dx=1.000 mm, dy=1.000 mm

Signal Type: Audio File (.wav) 48k_voice_1kHz_1s.wav

Output Gain: 100

Measure Window Start: 300ms

Measure Window Length: 1000ms

BWC applied: 0.16 dB

Device Reference Point: 0, 0, -6.3 mm

Cursor:

ABM1/ABM2 = 40.09 dB

ABM1 comp = -11.26 dBA/m

BWC Factor = 0.16 dB

Location: 2.5, -22, 3.7 mm

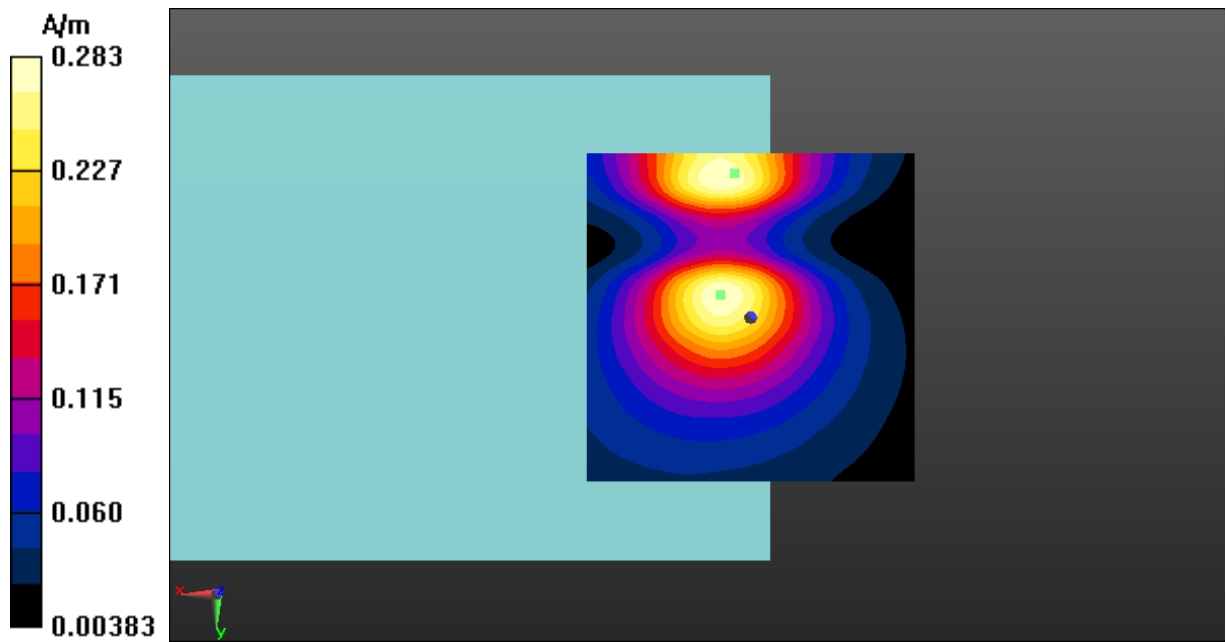

Fig A.10 T-Coil WCDMA Band 5-Y



T-Coil LTE-Band 7 Axial (Ant.0)

Date: 2023-2-9

Electronics: DAE4 Sn786

Medium: Air

Medium parameters used: $\sigma = 0$ S/m, $\epsilon_r = 1$; $\rho = 1$ kg/m³

Communication System: UID 0, LTE_FDD (0) Frequency: 2535 MHz Duty Cycle: 1:1

Probe: AM1DV3 - 3086

z (axial) 4.2mm 50 x 50/ABM Interpolated Signal(x,y,z) (101x101x1): Interpolated grid:

dx=1.000 mm, dy=1.000 mm

Signal Type: Audio File (.wav) 48k_voice_1kHz_1s.wav

Output Gain: 100

Measure Window Start: 300ms

Measure Window Length: 1000ms

BWC applied: 0.16 dB

Device Reference Point: 0, 0, -6.3 mm

Cursor:

ABM1 = -1.58 dBA/m

BWC Factor = 0.16 dB

Location: 6.5, -11, 3.7 mm

z (axial) 4.2mm 50 x 50/ABM Interpolated SNR(x,y,z) (101x101x1): Interpolated grid: dx=1.000 mm, dy=1.000 mm

Signal Type: Audio File (.wav) 48k_voice_1kHz_1s.wav

Output Gain: 100

Measure Window Start: 300ms

Measure Window Length: 1000ms

BWC applied: 0.16 dB

Device Reference Point: 0, 0, -6.3 mm

Cursor:

ABM1/ABM2 = 44.77 dB

ABM1 comp = -1.81 dBA/m

BWC Factor = 0.16 dB

Location: 5, -10, 3.7 mm

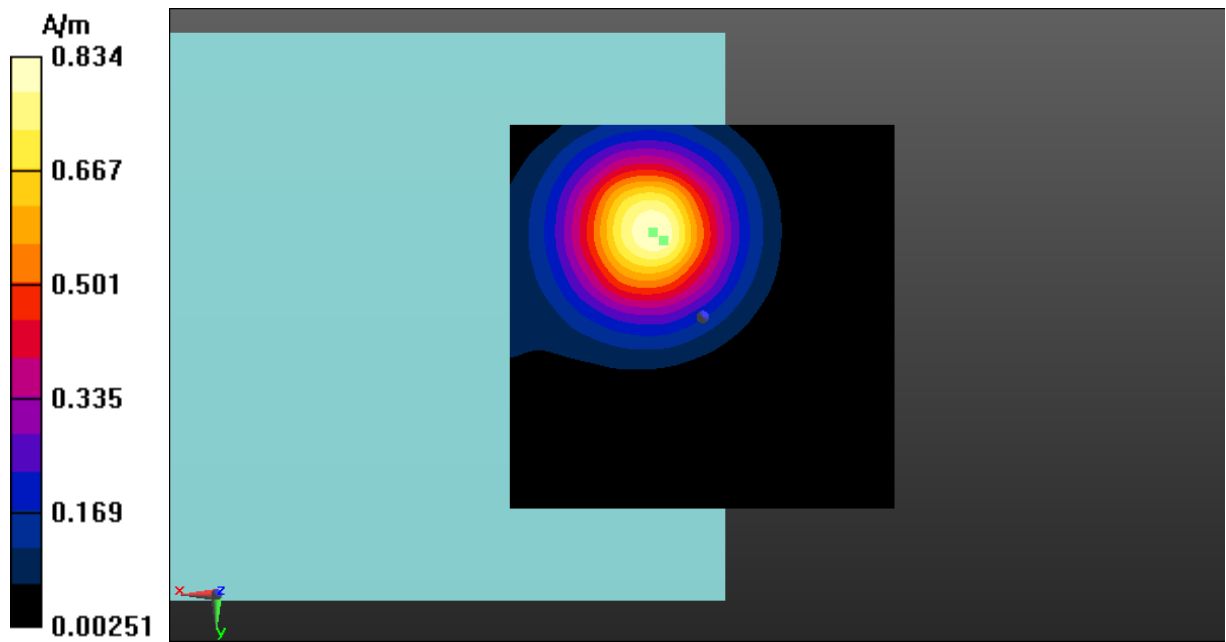

Fig A.11 T-Coil LTE-Band 7-Z



T-Coil LTE-Band 7 Transverse (Ant.0)

Date: 2023-2-9

Electronics: DAE4 Sn786

Medium: Air

Medium parameters used: $\sigma = 0$ S/m, $\epsilon_r = 1$; $\rho = 1$ kg/m³

Communication System: UID 0, LTE_FDD (0) Frequency: 2535 MHz Duty Cycle: 1:1

Probe: AM1DV3 - 3086

y (transversal) 4.2mm 50 x 50/ABM Interpolated Signal(x,y,z) (101x101x1): Interpolated grid:

dx=1.000 mm, dy=1.000 mm

Signal Type: Audio File (.wav) 48k_voice_1kHz_1s.wav

Output Gain: 100

Measure Window Start: 300ms

Measure Window Length: 1000ms

BWC applied: 0.16 dB

Device Reference Point: 0, 0, -6.3 mm

Cursor:

ABM1 = -11.25 dBA/m

BWC Factor = 0.16 dB

Location: 4.5, -3.5, 3.7 mm

y (transversal) 4.2mm 50 x 50/ABM Interpolated SNR(x,y,z) (101x101x1): Interpolated grid:

dx=1.000 mm, dy=1.000 mm

Signal Type: Audio File (.wav) 48k_voice_1kHz_1s.wav

Output Gain: 100

Measure Window Start: 300ms

Measure Window Length: 1000ms

BWC applied: 0.16 dB

Device Reference Point: 0, 0, -6.3 mm

Cursor:

ABM1/ABM2 = 35.69 dB

ABM1 comp = -13.56 dBA/m

BWC Factor = 0.16 dB

Location: -3, -3.5, 3.7 mm

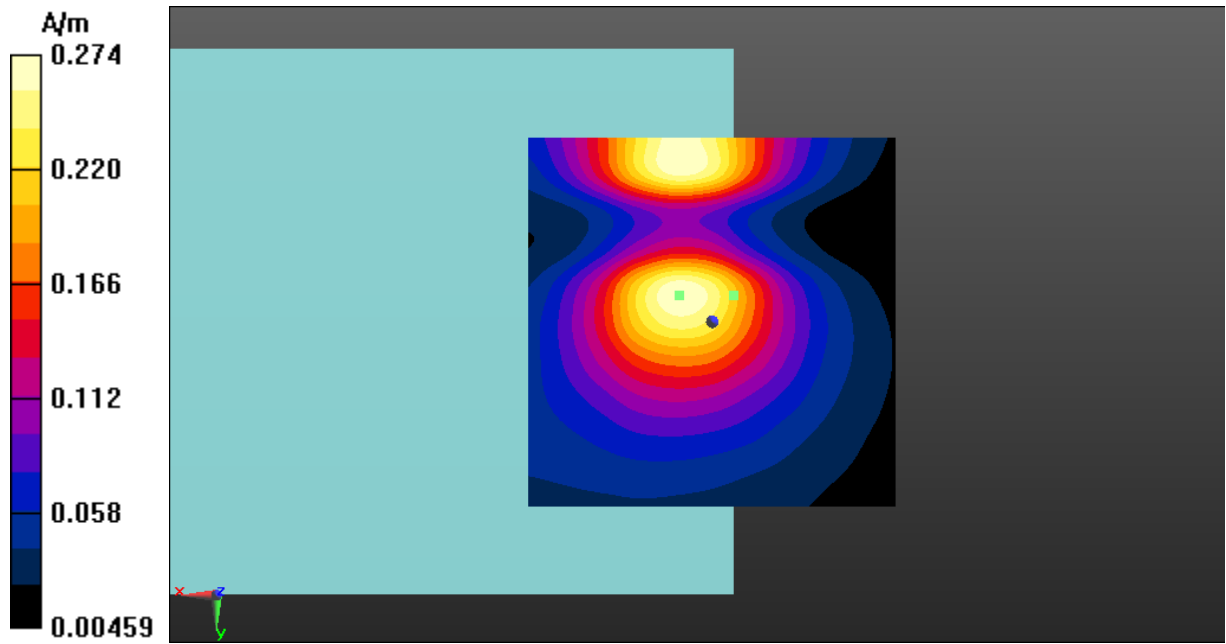

Fig A.11 T-Coil LTE-Band 7-Y



T-Coil LTE-Band 7 Axial (Ant.2)

Date: 2023-2-9

Electronics: DAE4 Sn786

Medium: Air

Medium parameters used: $\sigma = 0$ S/m, $\epsilon_r = 1$; $\rho = 1$ kg/m³

Communication System: UID 0, LTE_FDD (0) Frequency: 2535 MHz Duty Cycle: 1:1

Probe: AM1DV3 - 3086

z (axial) 4.2mm 50 x 50/ABM Interpolated Signal(x,y,z) (101x101x1): Interpolated grid:

dx=1.000 mm, dy=1.000 mm

Signal Type: Audio File (.wav) 48k_voice_1kHz_1s.wav

Output Gain: 100

Measure Window Start: 300ms

Measure Window Length: 1000ms

BWC applied: 0.16 dB

Device Reference Point: 0, 0, -6.3 mm

Cursor:

ABM1 = -1.22 dBA/m

BWC Factor = 0.16 dB

Location: 7, -11, 3.7 mm

z (axial) 4.2mm 50 x 50/ABM Interpolated SNR(x,y,z) (101x101x1): Interpolated grid: dx=1.000 mm, dy=1.000 mm

Signal Type: Audio File (.wav) 48k_voice_1kHz_1s.wav

Output Gain: 100

Measure Window Start: 300ms

Measure Window Length: 1000ms

BWC applied: 0.16 dB

Device Reference Point: 0, 0, -6.3 mm

Cursor:

ABM1/ABM2 = 41.20 dB

ABM1 comp = -1.50 dBA/m

BWC Factor = 0.16 dB

Location: 5, -11, 3.7 mm

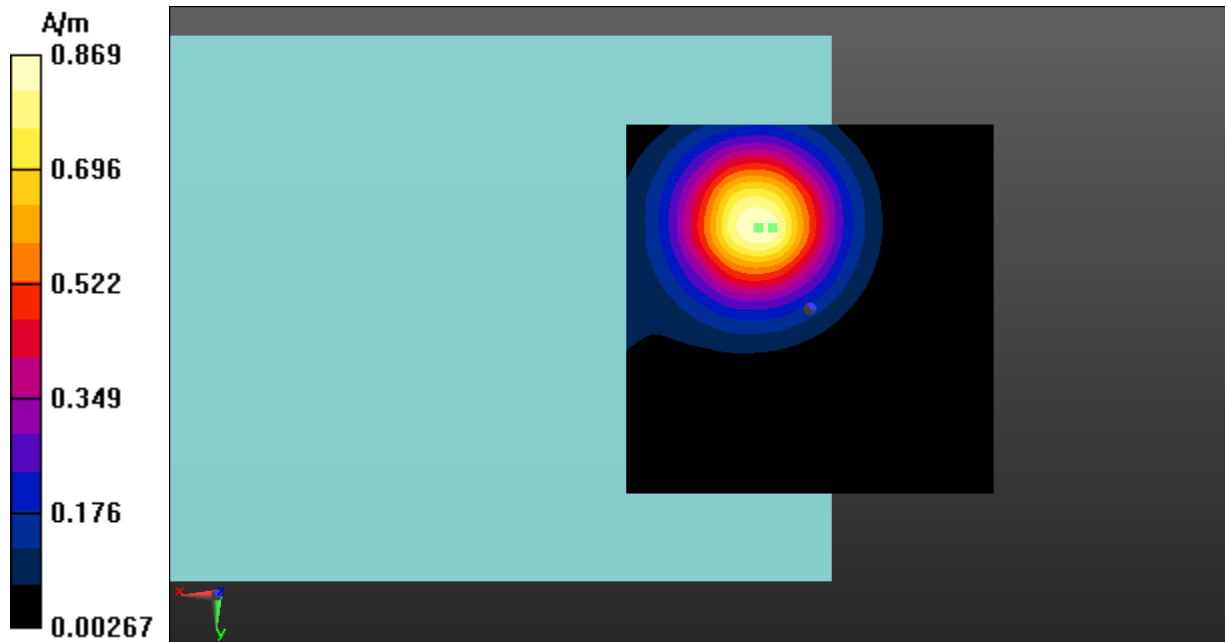

Fig A.12 T-Coil LTE-Band 7-Z



T-Coil LTE-Band 7 Transverse (Ant.2)

Date: 2023-2-9

Electronics: DAE4 Sn786

Medium: Air

Medium parameters used: $\sigma = 0$ S/m, $\epsilon_r = 1$; $\rho = 1$ kg/m³

Communication System: UID 0, LTE_FDD (0) Frequency: 2535 MHz Duty Cycle: 1:1

Probe: AM1DV3 - 3086

y (transversal) 4.2mm 50 x 50/ABM Interpolated Signal(x,y,z) (101x101x1): Interpolated grid:

dx=1.000 mm, dy=1.000 mm

Signal Type: Audio File (.wav) 48k_voice_1kHz_1s.wav

Output Gain: 100

Measure Window Start: 300ms

Measure Window Length: 1000ms

BWC applied: 0.16 dB

Device Reference Point: 0, 0, -6.3 mm

Cursor:

ABM1 = -10.88 dBA/m

BWC Factor = 0.16 dB

Location: 4, -4, 3.7 mm

y (transversal) 4.2mm 50 x 50/ABM Interpolated SNR(x,y,z) (101x101x1): Interpolated grid:

dx=1.000 mm, dy=1.000 mm

Signal Type: Audio File (.wav) 48k_voice_1kHz_1s.wav

Output Gain: 100

Measure Window Start: 300ms

Measure Window Length: 1000ms

BWC applied: 0.16 dB

Device Reference Point: 0, 0, -6.3 mm

Cursor:

ABM1/ABM2 = 31.70 dB

ABM1 comp = -12.29 dBA/m

BWC Factor = 0.16 dB

Location: -1.5, -4, 3.7 mm

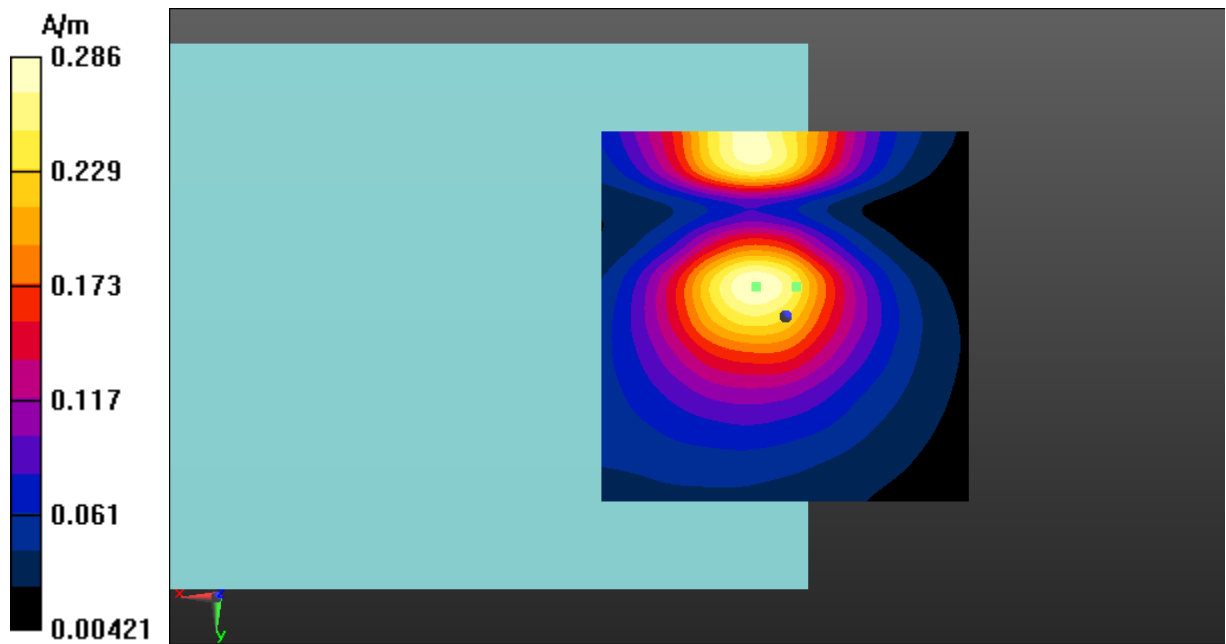

Fig A.12 T-Coil LTE-Band 7-Y



T-Coil LTE-Band 12 Axial (Ant.1)

Date: 2023-2-9

Electronics: DAE4 Sn786

Medium: Air

Medium parameters used: $\sigma = 0$ S/m, $\epsilon_r = 1$; $\rho = 1$ kg/m³

Communication System: UID 0, LTE_FDD (0) Frequency: 707.5 MHz Duty Cycle: 1:1

Probe: AM1DV3 - 3086

z (axial) 4.2mm 50 x 50/ABM Interpolated Signal(x,y,z) (101x101x1): Interpolated grid:

dx=1.000 mm, dy=1.000 mm

Signal Type: Audio File (.wav) 48k_voice_1kHz_1s.wav

Output Gain: 100

Measure Window Start: 300ms

Measure Window Length: 1000ms

BWC applied: 0.16 dB

Device Reference Point: 0, 0, -6.3 mm

Cursor:

ABM1 = -0.89 dBA/m

BWC Factor = 0.16 dB

Location: 6.5, -10, 3.7 mm

z (axial) 4.2mm 50 x 50/ABM Interpolated SNR(x,y,z) (101x101x1): Interpolated grid: dx=1.000 mm, dy=1.000 mm

Signal Type: Audio File (.wav) 48k_voice_1kHz_1s.wav

Output Gain: 100

Measure Window Start: 300ms

Measure Window Length: 1000ms

BWC applied: 0.16 dB

Device Reference Point: 0, 0, -6.3 mm

Cursor:

ABM1/ABM2 = 45.78 dB

ABM1 comp = -2.21 dBA/m

BWC Factor = 0.16 dB

Location: 4, -7.5, 3.7 mm

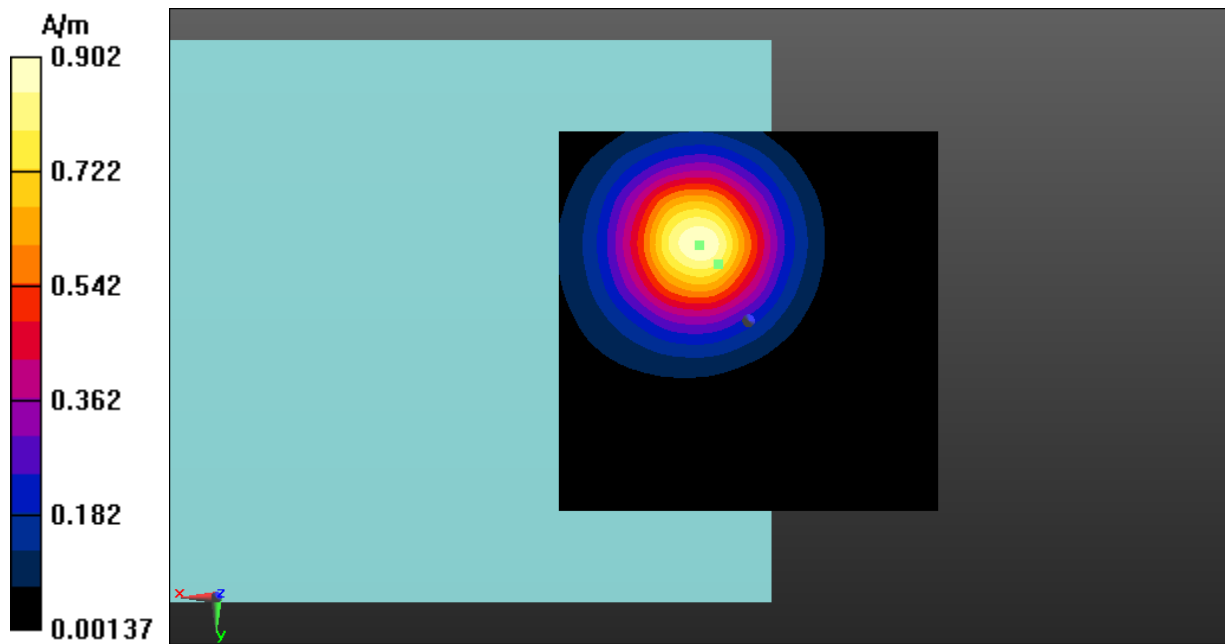

Fig A.13 T-Coil LTE-Band 12-Z



T-Coil LTE-Band 12 Transverse (Ant.1)

Date: 2023-2-9

Electronics: DAE4 Sn786

Medium: Air

Medium parameters used: $\sigma = 0$ S/m, $\epsilon_r = 1$; $\rho = 1$ kg/m³

Communication System: UID 0, LTE_FDD (0) Frequency: 707.5 MHz Duty Cycle: 1:1

Probe: AM1DV3 - 3086

y (transversal) 4.2mm 50 x 50/ABM Interpolated Signal(x,y,z) (101x101x1): Interpolated grid:

dx=1.000 mm, dy=1.000 mm

Signal Type: Audio File (.wav) 48k_voice_1kHz_1s.wav

Output Gain: 100

Measure Window Start: 300ms

Measure Window Length: 1000ms

BWC applied: 0.16 dB

Device Reference Point: 0, 0, -6.3 mm

Cursor:

ABM1 = -10.51 dBA/m

BWC Factor = 0.16 dB

Location: 4.5, -21, 3.7 mm

y (transversal) 4.2mm 50 x 50/ABM Interpolated SNR(x,y,z) (101x101x1): Interpolated grid:

dx=1.000 mm, dy=1.000 mm

Signal Type: Audio File (.wav) 48k_voice_1kHz_1s.wav

Output Gain: 100

Measure Window Start: 300ms

Measure Window Length: 1000ms

BWC applied: 0.16 dB

Device Reference Point: 0, 0, -6.3 mm

Cursor:

ABM1/ABM2 = 37.58 dB

ABM1 comp = -11.76 dBA/m

BWC Factor = 0.16 dB

Location: -0.5, -2, 3.7 mm

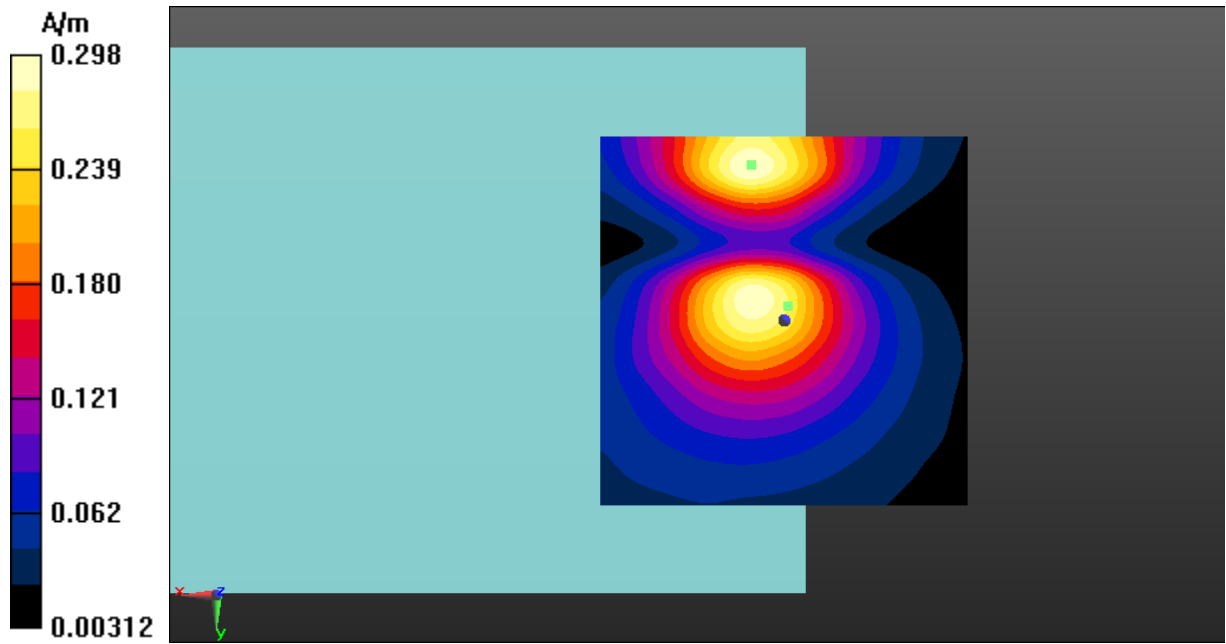

Fig A.13 T-Coil LTE-Band 12-Y



T-Coil LTE-Band 12 Axial (Ant.2)

Date: 2023-2-9

Electronics: DAE4 Sn786

Medium: Air

Medium parameters used: $\sigma = 0$ S/m, $\epsilon_r = 1$; $\rho = 1$ kg/m³

Communication System: UID 0, LTE_FDD (0) Frequency: 707.5 MHz Duty Cycle: 1:1

Probe: AM1DV3 - 3086

z (axial) 4.2mm 50 x 50/ABM Interpolated Signal(x,y,z) (101x101x1): Interpolated grid:

dx=1.000 mm, dy=1.000 mm

Signal Type: Audio File (.wav) 48k_voice_1kHz_1s.wav

Output Gain: 100

Measure Window Start: 300ms

Measure Window Length: 1000ms

BWC applied: 0.16 dB

Device Reference Point: 0, 0, -6.3 mm

Cursor:

ABM1 = -1.42 dBA/m

BWC Factor = 0.16 dB

Location: 7.5, -11, 3.7 mm

z (axial) 4.2mm 50 x 50/ABM Interpolated SNR(x,y,z) (101x101x1): Interpolated grid: dx=1.000

mm, dy=1.000 mm

Signal Type: Audio File (.wav) 48k_voice_1kHz_1s.wav

Output Gain: 100

Measure Window Start: 300ms

Measure Window Length: 1000ms

BWC applied: 0.16 dB

Device Reference Point: 0, 0, -6.3 mm

Cursor:

ABM1/ABM2 = 47.62 dB

ABM1 comp = -2.07 dBA/m

BWC Factor = 0.16 dB

Location: 4.5, -10, 3.7 mm

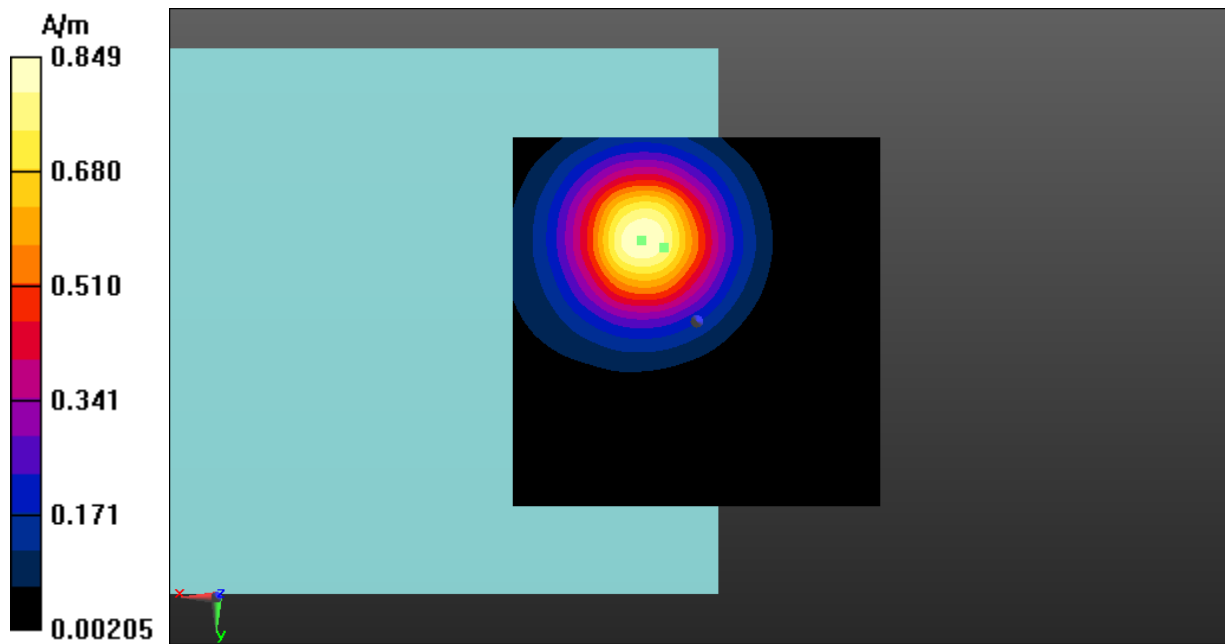

Fig A.14 T-Coil LTE-Band 12-Z



T-Coil LTE-Band 12 Transverse (Ant.2)

Date: 2023-2-9

Electronics: DAE4 Sn786

Medium: Air

Medium parameters used: $\sigma = 0$ S/m, $\epsilon_r = 1$; $\rho = 1$ kg/m³

Communication System: UID 0, LTE_FDD (0) Frequency: 707.5 MHz Duty Cycle: 1:1

Probe: AM1DV3 - 3086

y (transversal) 4.2mm 50 x 50/ABM Interpolated Signal(x,y,z) (101x101x1): Interpolated grid:

dx=1.000 mm, dy=1.000 mm

Signal Type: Audio File (.wav) 48k_voice_1kHz_1s.wav

Output Gain: 100

Measure Window Start: 300ms

Measure Window Length: 1000ms

BWC applied: 0.16 dB

Device Reference Point: 0, 0, -6.3 mm

Cursor:

ABM1 = -11.06 dBA/m

BWC Factor = 0.16 dB

Location: 4, -3.5, 3.7 mm

y (transversal) 4.2mm 50 x 50/ABM Interpolated SNR(x,y,z) (101x101x1): Interpolated grid:

dx=1.000 mm, dy=1.000 mm

Signal Type: Audio File (.wav) 48k_voice_1kHz_1s.wav

Output Gain: 100

Measure Window Start: 300ms

Measure Window Length: 1000ms

BWC applied: 0.16 dB

Device Reference Point: 0, 0, -6.3 mm

Cursor:

ABM1/ABM2 = 37.80 dB

ABM1 comp = -13.04 dBA/m

BWC Factor = 0.16 dB

Location: -2.5, -3, 3.7 mm

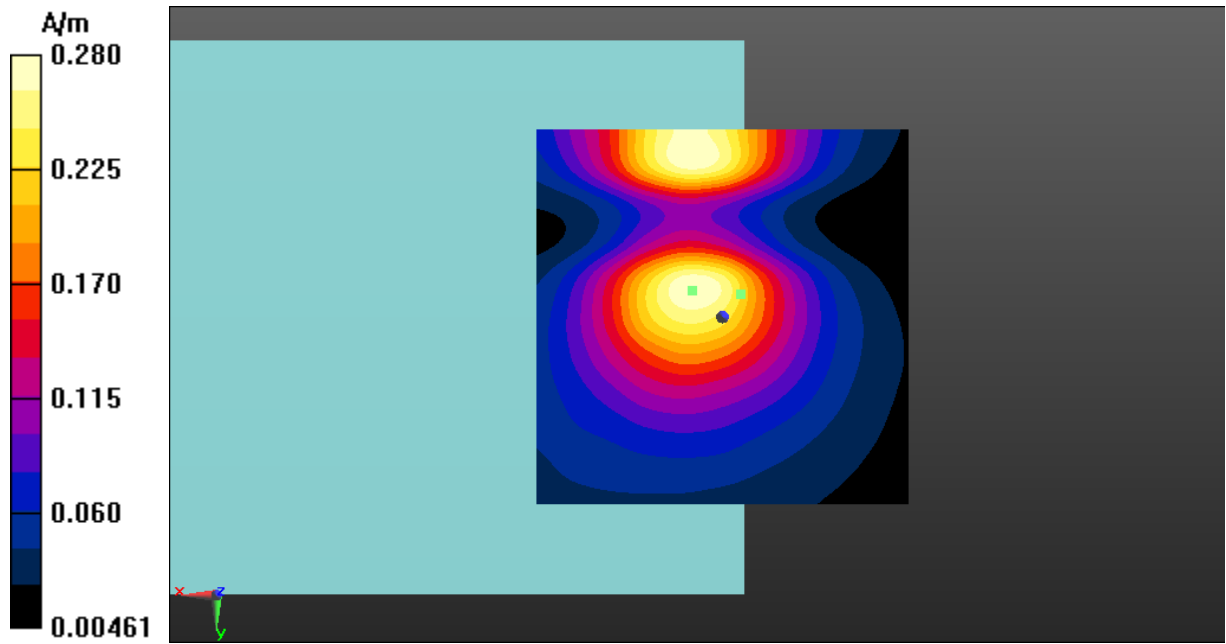

Fig A.14 T-Coil LTE-Band 12-Y



T-Coil LTE-Band 13 Axial (Ant.1)

Date: 2023-2-9

Electronics: DAE4 Sn786

Medium: Air

Medium parameters used: $\sigma = 0$ S/m, $\epsilon_r = 1$; $\rho = 1$ kg/m³

Communication System: UID 0, LTE_FDD (0) Frequency: 782 MHz Duty Cycle: 1:1

Probe: AM1DV3 - 3086

z (axial) 4.2mm 50 x 50/ABM Interpolated Signal(x,y,z) (101x101x1): Interpolated grid:

dx=1.000 mm, dy=1.000 mm

Signal Type: Audio File (.wav) 48k_voice_1kHz_1s.wav

Output Gain: 100

Measure Window Start: 300ms

Measure Window Length: 1000ms

BWC applied: 0.16 dB

Device Reference Point: 0, 0, -6.3 mm

Cursor:

ABM1 = -0.93 dBA/m

BWC Factor = 0.16 dB

Location: 7, -10, 3.7 mm

z (axial) 4.2mm 50 x 50/ABM Interpolated SNR(x,y,z) (101x101x1): Interpolated grid: dx=1.000 mm, dy=1.000 mm

Signal Type: Audio File (.wav) 48k_voice_1kHz_1s.wav

Output Gain: 100

Measure Window Start: 300ms

Measure Window Length: 1000ms

BWC applied: 0.16 dB

Device Reference Point: 0, 0, -6.3 mm

Cursor:

ABM1/ABM2 = 42.36 dB

ABM1 comp = -1.26 dBA/m

BWC Factor = 0.16 dB

Location: 5, -10, 3.7 mm

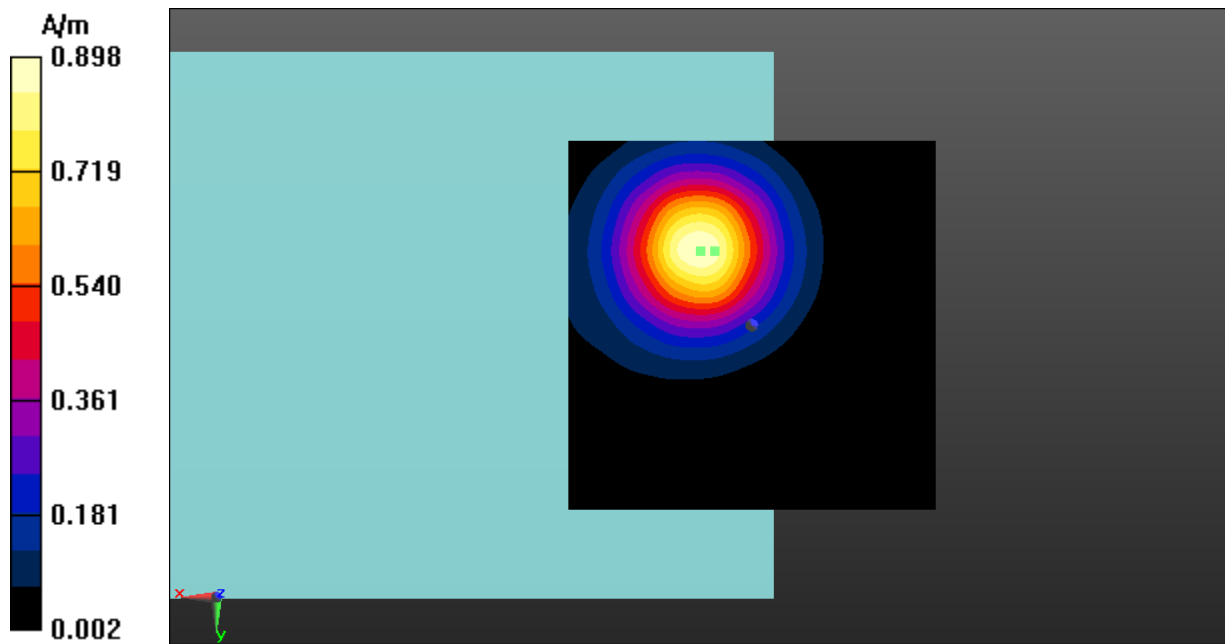

Fig A.15 T-Coil LTE-Band 13-Z



T-Coil LTE-Band 13 Transverse (Ant.1)

Date: 2023-2-9

Electronics: DAE4 Sn786

Medium: Air

Medium parameters used: $\sigma = 0$ S/m, $\epsilon_r = 1$; $\rho = 1$ kg/m³

Communication System: UID 0, LTE_FDD (0) Frequency: 782 MHz Duty Cycle: 1:1

Probe: AM1DV3 - 3086

y (transversal) 4.2mm 50 x 50/ABM Interpolated Signal(x,y,z) (101x101x1): Interpolated grid:

dx=1.000 mm, dy=1.000 mm

Signal Type: Audio File (.wav) 48k_voice_1kHz_1s.wav

Output Gain: 100

Measure Window Start: 300ms

Measure Window Length: 1000ms

BWC applied: 0.16 dB

Device Reference Point: 0, 0, -6.3 mm

Cursor:

ABM1 = -10.66 dBA/m

BWC Factor = 0.16 dB

Location: 4.5, -21, 3.7 mm

y (transversal) 4.2mm 50 x 50/ABM Interpolated SNR(x,y,z) (101x101x1): Interpolated grid:

dx=1.000 mm, dy=1.000 mm

Signal Type: Audio File (.wav) 48k_voice_1kHz_1s.wav

Output Gain: 100

Measure Window Start: 300ms

Measure Window Length: 1000ms

BWC applied: 0.16 dB

Device Reference Point: 0, 0, -6.3 mm

Cursor:

ABM1/ABM2 = 33.16 dB

ABM1 comp = -12.60 dBA/m

BWC Factor = 0.16 dB

Location: -2, -21, 3.7 mm

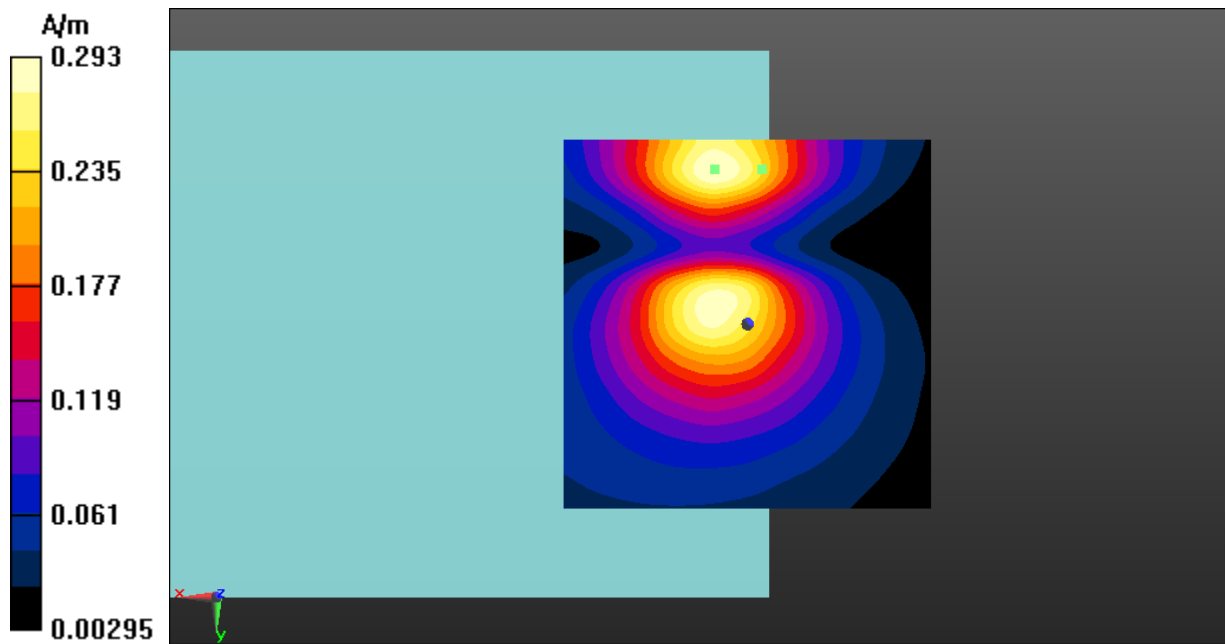

Fig A.15 T-Coil LTE-Band 13-Y



T-Coil LTE-Band 13 Axial (Ant.2)

Date: 2023-2-9

Electronics: DAE4 Sn786

Medium: Air

Medium parameters used: $\sigma = 0$ S/m, $\epsilon_r = 1$; $\rho = 1$ kg/m³

Communication System: UID 0, LTE_FDD (0) Frequency: 782 MHz Duty Cycle: 1:1

Probe: AM1DV3 - 3086

z (axial) 4.2mm 50 x 50/ABM Interpolated Signal(x,y,z) (101x101x1): Interpolated grid:

dx=1.000 mm, dy=1.000 mm

Signal Type: Audio File (.wav) 48k_voice_1kHz_1s.wav

Output Gain: 100

Measure Window Start: 300ms

Measure Window Length: 1000ms

BWC applied: 0.16 dB

Device Reference Point: 0, 0, -6.3 mm

Cursor:

ABM1 = -1.48 dBA/m

BWC Factor = 0.16 dB

Location: 7.5, -11, 3.7 mm

z (axial) 4.2mm 50 x 50/ABM Interpolated SNR(x,y,z) (101x101x1): Interpolated grid: dx=1.000

mm, dy=1.000 mm

Signal Type: Audio File (.wav) 48k_voice_1kHz_1s.wav

Output Gain: 100

Measure Window Start: 300ms

Measure Window Length: 1000ms

BWC applied: 0.16 dB

Device Reference Point: 0, 0, -6.3 mm

Cursor:

ABM1/ABM2 = 46.06 dB

ABM1 comp = -2.24 dBA/m

BWC Factor = 0.16 dB

Location: 4.5, -9.5, 3.7 mm

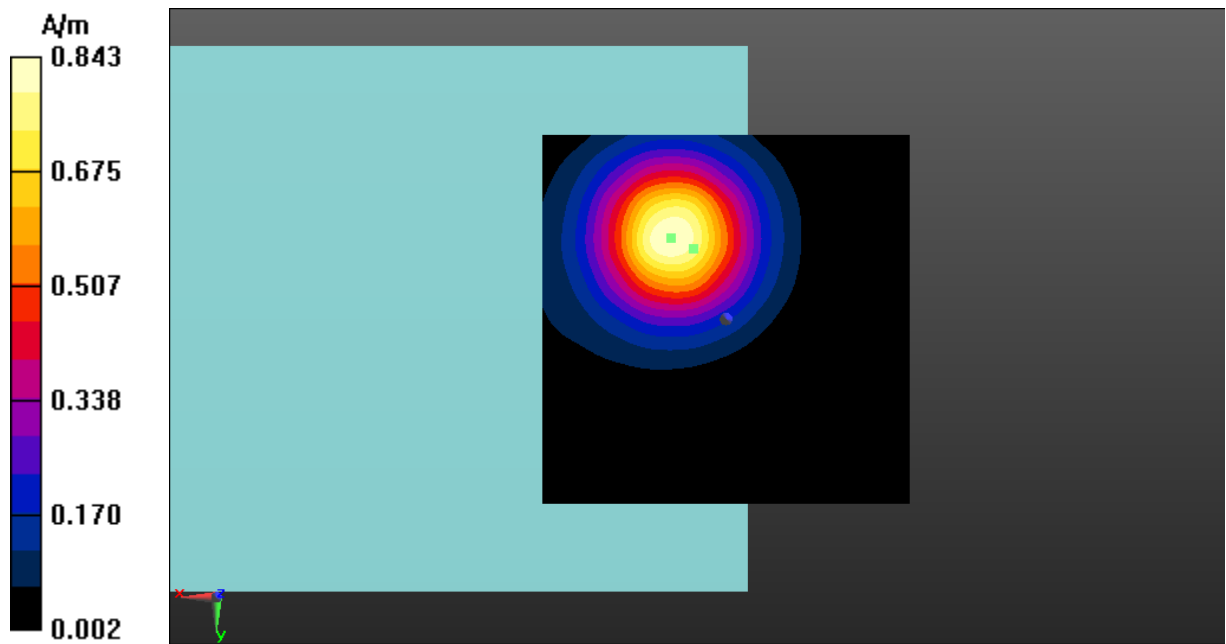

Fig A.16 T-Coil LTE-Band 13-Z



T-Coil LTE-Band 13 Transverse (Ant.2)

Date: 2023-2-9

Electronics: DAE4 Sn786

Medium: Air

Medium parameters used: $\sigma = 0$ S/m, $\epsilon_r = 1$; $\rho = 1$ kg/m³

Communication System: UID 0, LTE_FDD (0) Frequency: 782 MHz Duty Cycle: 1:1

Probe: AM1DV3 - 3086

y (transversal) 4.2mm 50 x 50/ABM Interpolated Signal(x,y,z) (101x101x1): Interpolated grid:

dx=1.000 mm, dy=1.000 mm

Signal Type: Audio File (.wav) 48k_voice_1kHz_1s.wav

Output Gain: 100

Measure Window Start: 300ms

Measure Window Length: 1000ms

BWC applied: 0.16 dB

Device Reference Point: 0, 0, -6.3 mm

Cursor:

ABM1 = -11.06 dBA/m

BWC Factor = 0.16 dB

Location: 4.5, -3.5, 3.7 mm

y (transversal) 4.2mm 50 x 50/ABM Interpolated SNR(x,y,z) (101x101x1): Interpolated grid:

dx=1.000 mm, dy=1.000 mm

Signal Type: Audio File (.wav) 48k_voice_1kHz_1s.wav

Output Gain: 100

Measure Window Start: 300ms

Measure Window Length: 1000ms

BWC applied: 0.16 dB

Device Reference Point: 0, 0, -6.3 mm

Cursor:

ABM1/ABM2 = 37.16 dB

ABM1 comp = -13.52 dBA/m

BWC Factor = 0.16 dB

Location: -3, -1.5, 3.7 mm

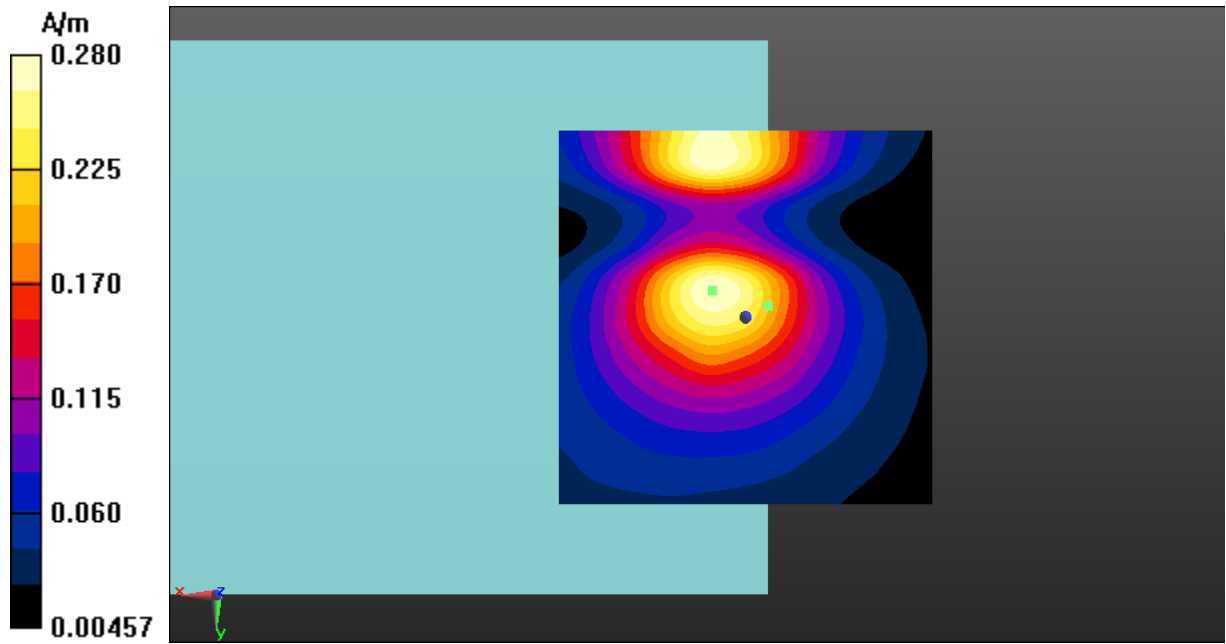

Fig A.16 T-Coil LTE-Band 13-Y



T-Coil LTE-Band 25 Axial (Ant.0)

Date: 2023-2-9

Electronics: DAE4 Sn786

Medium: Air

Medium parameters used: $\sigma = 0$ S/m, $\epsilon_r = 1$; $\rho = 1$ kg/m³

Communication System: UID 0, LTE_FDD (0) Frequency: 1882.5 MHz Duty Cycle: 1:1

Probe: AM1DV3 - 3086

z (axial) 4.2mm 50 x 50/ABM Interpolated Signal(x,y,z) (101x101x1): Interpolated grid:

dx=1.000 mm, dy=1.000 mm

Signal Type: Audio File (.wav) 48k_voice_1kHz_1s.wav

Output Gain: 100

Measure Window Start: 300ms

Measure Window Length: 1000ms

BWC applied: 0.16 dB

Device Reference Point: 0, 0, -6.3 mm

Cursor:

ABM1 = -1.54 dBA/m

BWC Factor = 0.16 dB

Location: 7, -11, 3.7 mm

z (axial) 4.2mm 50 x 50/ABM Interpolated SNR(x,y,z) (101x101x1): Interpolated grid: dx=1.000 mm, dy=1.000 mm

Signal Type: Audio File (.wav) 48k_voice_1kHz_1s.wav

Output Gain: 100

Measure Window Start: 300ms

Measure Window Length: 1000ms

BWC applied: 0.16 dB

Device Reference Point: 0, 0, -6.3 mm

Cursor:

ABM1/ABM2 = 44.39 dB

ABM1 comp = -1.91 dBA/m

BWC Factor = 0.16 dB

Location: 5, -10, 3.7 mm

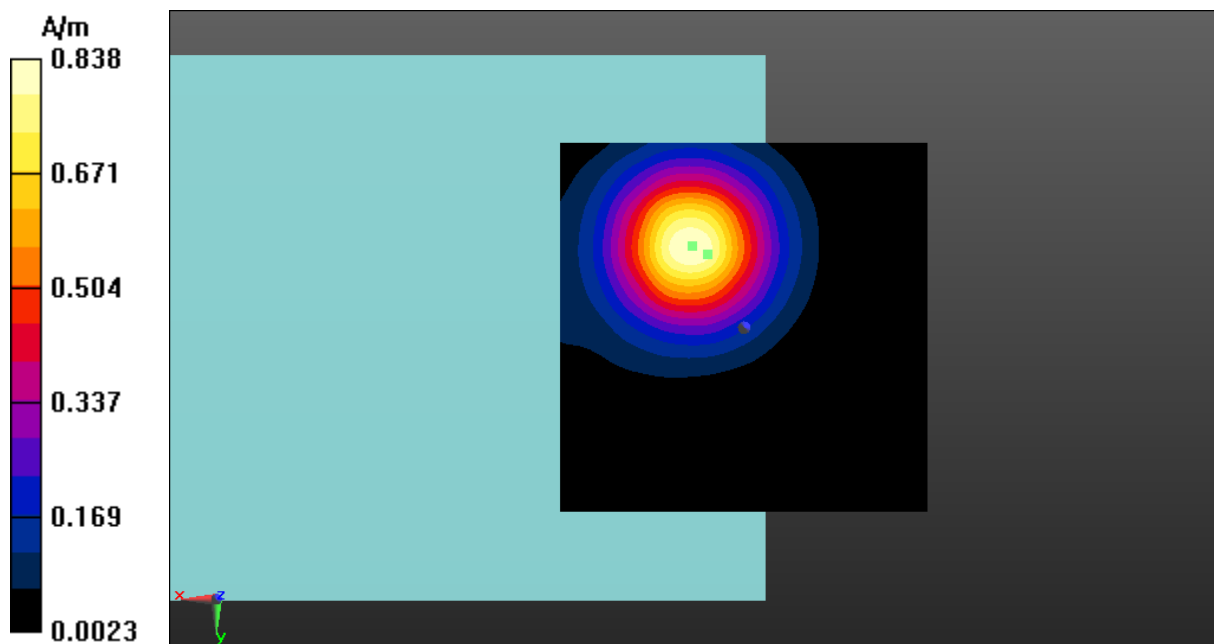

Fig A.17 T-Coil LTE-Band 25-Z



T-Coil LTE-Band 25 Transverse (Ant.0)

Date: 2023-2-9

Electronics: DAE4 Sn786

Medium: Air

Medium parameters used: $\sigma = 0$ S/m, $\epsilon_r = 1$; $\rho = 1$ kg/m³

Communication System: UID 0, LTE_FDD (0) Frequency: 1882.5 MHz Duty Cycle: 1:1

Probe: AM1DV3 - 3086

y (transversal) 4.2mm 50 x 50/ABM Interpolated Signal(x,y,z) (101x101x1): Interpolated grid:

dx=1.000 mm, dy=1.000 mm

Signal Type: Audio File (.wav) 48k_voice_1kHz_1s.wav

Output Gain: 100

Measure Window Start: 300ms

Measure Window Length: 1000ms

BWC applied: 0.16 dB

Device Reference Point: 0, 0, -6.3 mm

Cursor:

ABM1 = -11.11 dBA/m

BWC Factor = 0.16 dB

Location: 4.5, -21.5, 3.7 mm

y (transversal) 4.2mm 50 x 50/ABM Interpolated SNR(x,y,z) (101x101x1): Interpolated grid:

dx=1.000 mm, dy=1.000 mm

Signal Type: Audio File (.wav) 48k_voice_1kHz_1s.wav

Output Gain: 100

Measure Window Start: 300ms

Measure Window Length: 1000ms

BWC applied: 0.16 dB

Device Reference Point: 0, 0, -6.3 mm

Cursor:

ABM1/ABM2 = 35.14 dB

ABM1 comp = -13.15 dBA/m

BWC Factor = 0.16 dB

Location: -2.5, -3, 3.7 mm

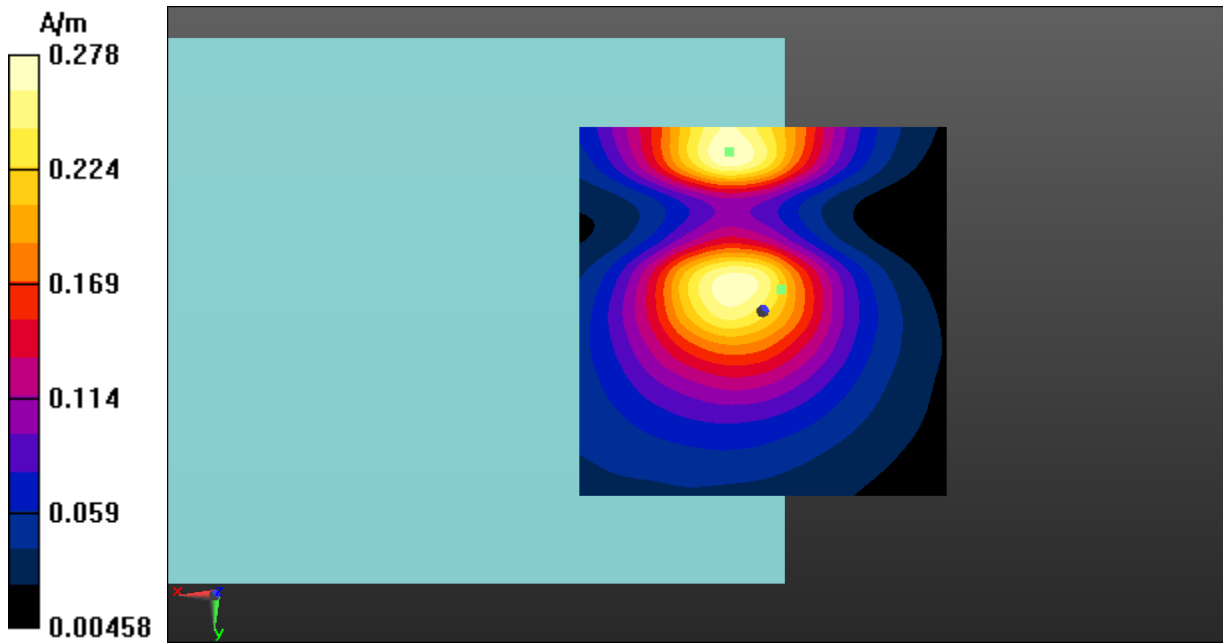

Fig A.17 T-Coil LTE-Band 25-Y



T-Coil LTE-Band 25 Axial (Ant.2)

Date: 2023-2-9

Electronics: DAE4 Sn786

Medium: Air

Medium parameters used: $\sigma = 0$ S/m, $\epsilon_r = 1$; $\rho = 1$ kg/m³

Communication System: UID 0, LTE_FDD (0) Frequency: 1882.5 MHz Duty Cycle: 1:1

Probe: AM1DV3 - 3086

z (axial) 4.2mm 50 x 50/ABM Interpolated Signal(x,y,z) (101x101x1): Interpolated grid:

dx=1.000 mm, dy=1.000 mm

Signal Type: Audio File (.wav) 48k_voice_1kHz_1s.wav

Output Gain: 100

Measure Window Start: 300ms

Measure Window Length: 1000ms

BWC applied: 0.16 dB

Device Reference Point: 0, 0, -6.3 mm

Cursor:

ABM1 = -1.44 dBA/m

BWC Factor = 0.16 dB

Location: 6.5, -11.5, 3.7 mm

z (axial) 4.2mm 50 x 50/ABM Interpolated SNR(x,y,z) (101x101x1): Interpolated grid: dx=1.000

mm, dy=1.000 mm

Signal Type: Audio File (.wav) 48k_voice_1kHz_1s.wav

Output Gain: 100

Measure Window Start: 300ms

Measure Window Length: 1000ms

BWC applied: 0.16 dB

Device Reference Point: 0, 0, -6.3 mm

Cursor:

ABM1/ABM2 = 41.11 dB

ABM1 comp = -1.69 dBA/m

BWC Factor = 0.16 dB

Location: 5, -10.5, 3.7 mm

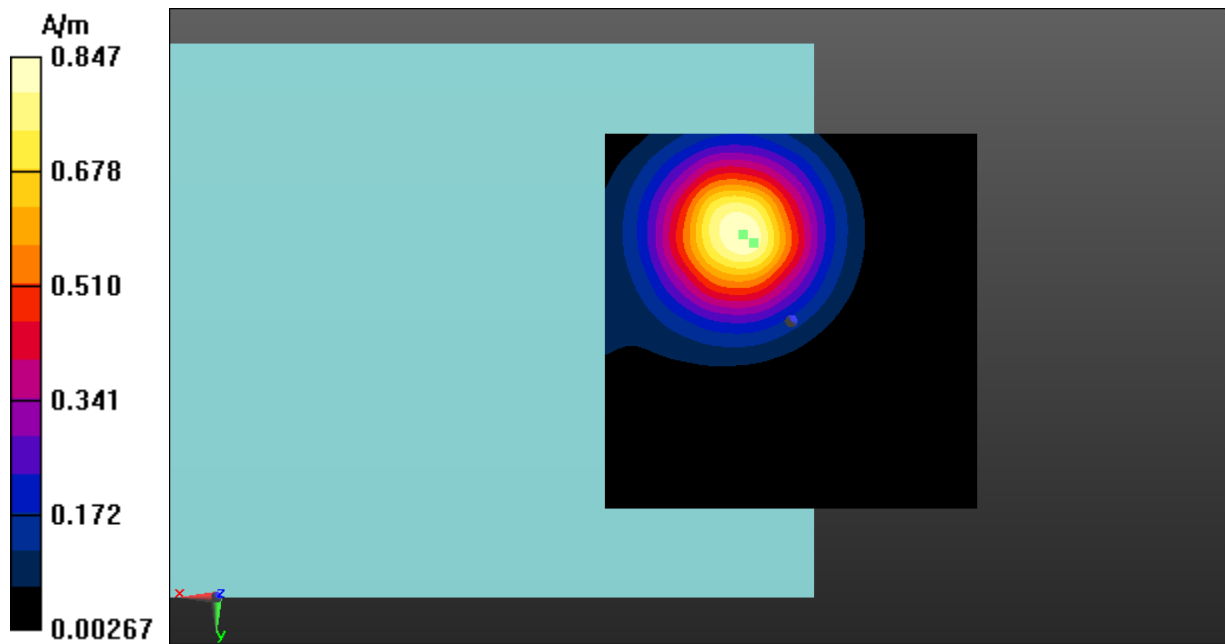

Fig A.18 T-Coil LTE-Band 25-Z



T-Coil LTE-Band 25 Transverse (Ant.2)

Date: 2023-2-9

Electronics: DAE4 Sn786

Medium: Air

Medium parameters used: $\sigma = 0$ S/m, $\epsilon_r = 1$; $\rho = 1$ kg/m³

Communication System: UID 0, LTE_FDD (0) Frequency: 1882.5 MHz Duty Cycle: 1:1

Probe: AM1DV3 - 3086

y (transversal) 4.2mm 50 x 50/ABM Interpolated Signal(x,y,z) (101x101x1): Interpolated grid:

dx=1.000 mm, dy=1.000 mm

Signal Type: Audio File (.wav) 48k_voice_1kHz_1s.wav

Output Gain: 100

Measure Window Start: 300ms

Measure Window Length: 1000ms

BWC applied: 0.16 dB

Device Reference Point: 0, 0, -6.3 mm

Cursor:

ABM1 = -11.00 dBA/m

BWC Factor = 0.16 dB

Location: 4.5, -22, 3.7 mm

y (transversal) 4.2mm 50 x 50/ABM Interpolated SNR(x,y,z) (101x101x1): Interpolated grid:

dx=1.000 mm, dy=1.000 mm

Signal Type: Audio File (.wav) 48k_voice_1kHz_1s.wav

Output Gain: 100

Measure Window Start: 300ms

Measure Window Length: 1000ms

BWC applied: 0.16 dB

Device Reference Point: 0, 0, -6.3 mm

Cursor:

ABM1/ABM2 = 31.40 dB

ABM1 comp = -12.77 dBA/m

BWC Factor = 0.16 dB

Location: -2, -4, 3.7 mm

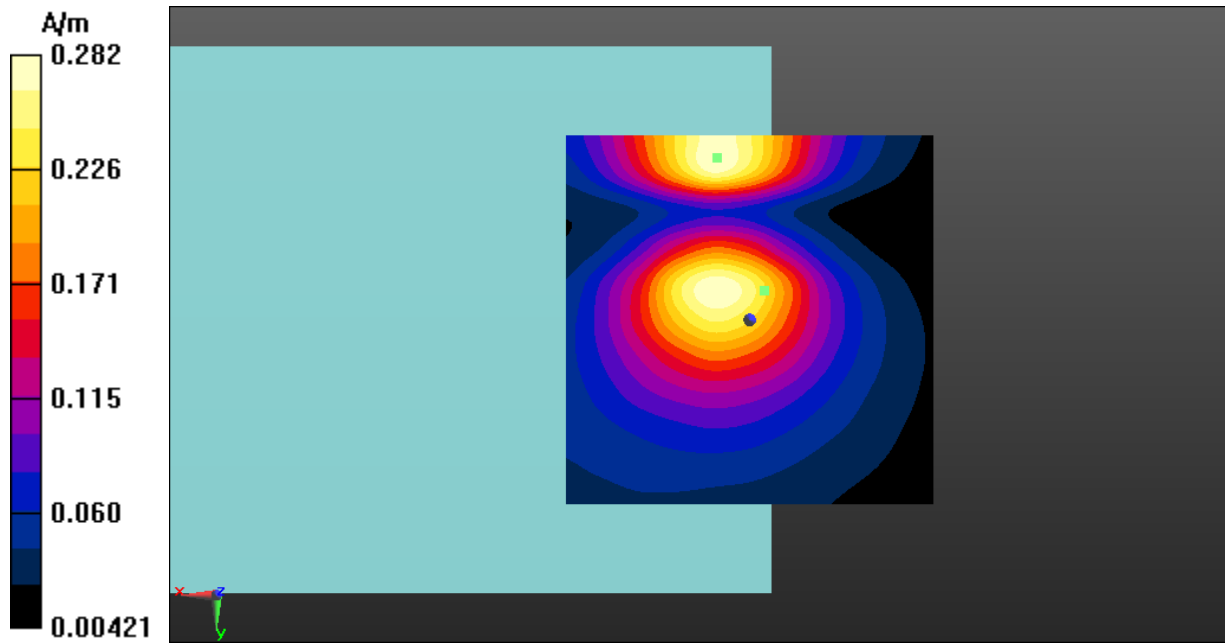

Fig A.18 T-Coil LTE-Band 25-Y



T-Coil LTE-Band 26 Axial (Ant.1)

Date: 2023-2-9

Electronics: DAE4 Sn786

Medium: Air

Medium parameters used: $\sigma = 0$ S/m, $\epsilon_r = 1$; $\rho = 1$ kg/m³

Communication System: UID 0, LTE_FDD (0) Frequency: 831.5 MHz Duty Cycle: 1:1

Probe: AM1DV3 - 3086

z (axial) 4.2mm 50 x 50/ABM Interpolated Signal(x,y,z) (101x101x1): Interpolated grid:

dx=1.000 mm, dy=1.000 mm

Signal Type: Audio File (.wav) 48k_voice_1kHz_1s.wav

Output Gain: 100

Measure Window Start: 300ms

Measure Window Length: 1000ms

BWC applied: 0.16 dB

Device Reference Point: 0, 0, -6.3 mm

Cursor:

ABM1 = -0.82 dBA/m

BWC Factor = 0.16 dB

Location: 7, -10, 3.7 mm

z (axial) 4.2mm 50 x 50/ABM Interpolated SNR(x,y,z) (101x101x1): Interpolated grid: dx=1.000

mm, dy=1.000 mm

Signal Type: Audio File (.wav) 48k_voice_1kHz_1s.wav

Output Gain: 100

Measure Window Start: 300ms

Measure Window Length: 1000ms

BWC applied: 0.16 dB

Device Reference Point: 0, 0, -6.3 mm

Cursor:

ABM1/ABM2 = 46.30 dB

ABM1 comp = -1.18 dBA/m

BWC Factor = 0.16 dB

Location: 5, -9.5, 3.7 mm

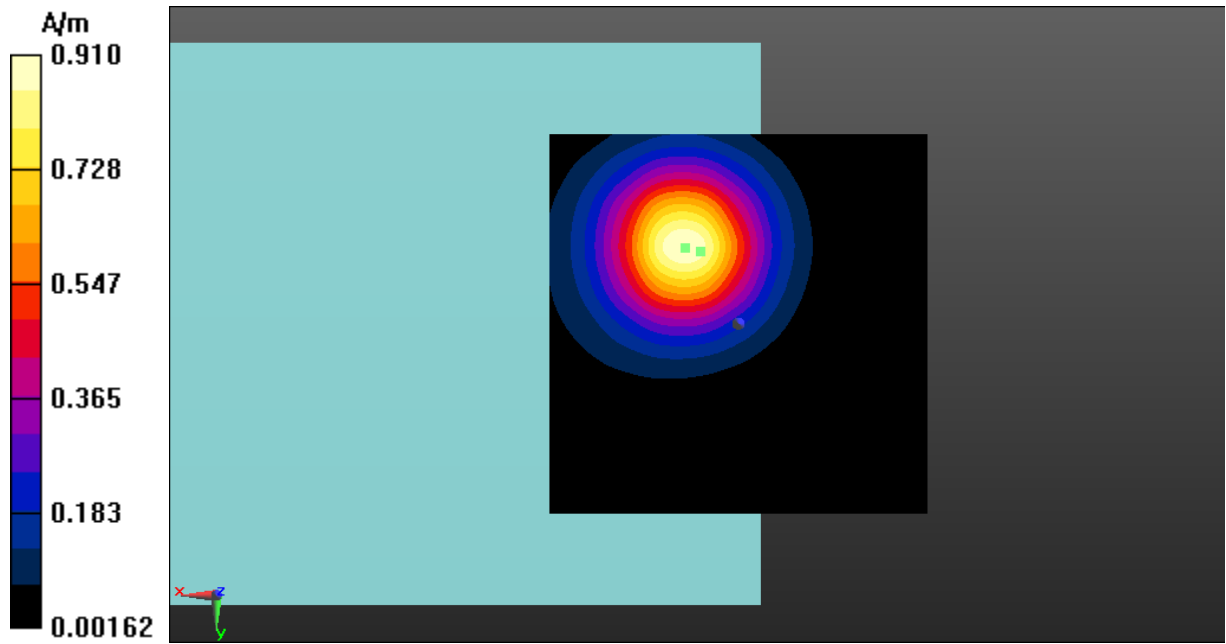

Fig A.19 T-Coil LTE-Band 26-Z



T-Coil LTE-Band 26 Transverse (Ant.1)

Date: 2023-2-9

Electronics: DAE4 Sn786

Medium: Air

Medium parameters used: $\sigma = 0$ S/m, $\epsilon_r = 1$; $\rho = 1$ kg/m³

Communication System: UID 0, LTE_FDD (0) Frequency: 831.5 MHz Duty Cycle: 1:1

Probe: AM1DV3 - 3086

y (transversal) 4.2mm 50 x 50/ABM Interpolated Signal(x,y,z) (101x101x1): Interpolated grid:

dx=1.000 mm, dy=1.000 mm

Signal Type: Audio File (.wav) 48k_voice_1kHz_1s.wav

Output Gain: 100

Measure Window Start: 300ms

Measure Window Length: 1000ms

BWC applied: 0.16 dB

Device Reference Point: 0, 0, -6.3 mm

Cursor:

ABM1 = -10.63 dBA/m

BWC Factor = 0.16 dB

Location: 4.5, -21, 3.7 mm

y (transversal) 4.2mm 50 x 50/ABM Interpolated SNR(x,y,z) (101x101x1): Interpolated grid:

dx=1.000 mm, dy=1.000 mm

Signal Type: Audio File (.wav) 48k_voice_1kHz_1s.wav

Output Gain: 100

Measure Window Start: 300ms

Measure Window Length: 1000ms

BWC applied: 0.16 dB

Device Reference Point: 0, 0, -6.3 mm

Cursor:

ABM1/ABM2 = 36.83 dB

ABM1 comp = -11.81 dBA/m

BWC Factor = 0.16 dB

Location: 0, -1.5, 3.7 mm

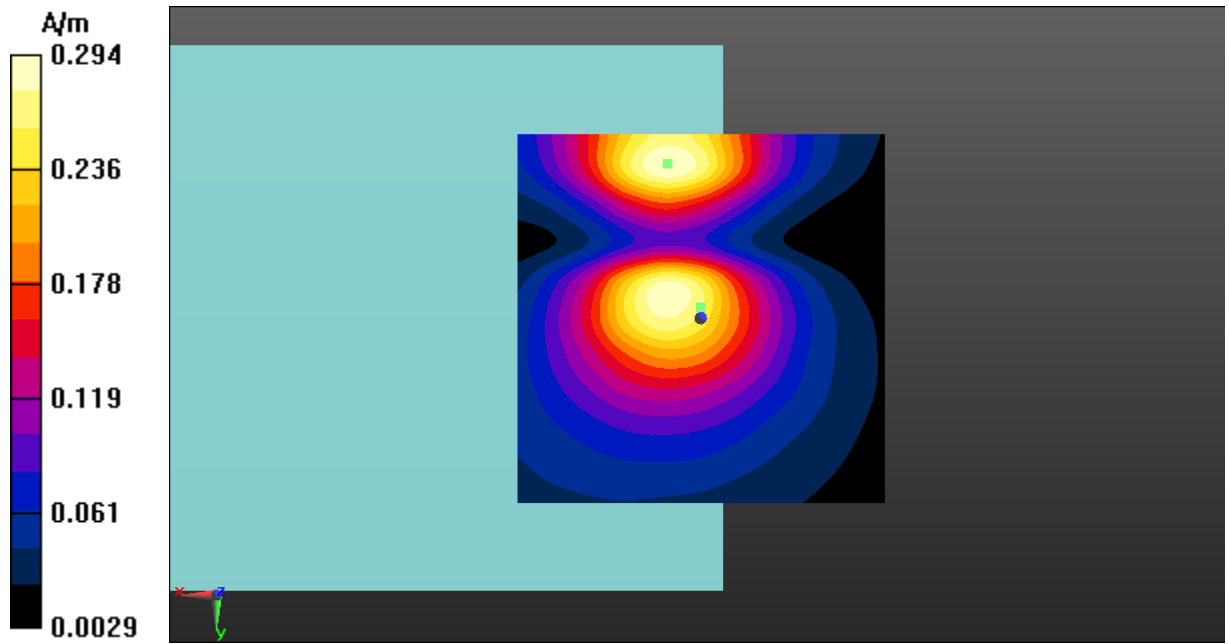

Fig A.19 T-Coil LTE-Band 26-Y



T-Coil LTE-Band 26 Axial (Ant.2)

Date: 2023-2-9

Electronics: DAE4 Sn786

Medium: Air

Medium parameters used: $\sigma = 0$ S/m, $\epsilon_r = 1$; $\rho = 1$ kg/m³

Communication System: UID 0, LTE_FDD (0) Frequency: 831.5 MHz Duty Cycle: 1:1

Probe: AM1DV3 - 3086

z (axial) 4.2mm 50 x 50/ABM Interpolated Signal(x,y,z) (101x101x1): Interpolated grid:

dx=1.000 mm, dy=1.000 mm

Signal Type: Audio File (.wav) 48k_voice_1kHz_1s.wav

Output Gain: 100

Measure Window Start: 300ms

Measure Window Length: 1000ms

BWC applied: 0.16 dB

Device Reference Point: 0, 0, -6.3 mm

Cursor:

ABM1 = -1.37 dBA/m

BWC Factor = 0.16 dB

Location: 7, -11, 3.7 mm

z (axial) 4.2mm 50 x 50/ABM Interpolated SNR(x,y,z) (101x101x1): Interpolated grid: dx=1.000 mm, dy=1.000 mm

Signal Type: Audio File (.wav) 48k_voice_1kHz_1s.wav

Output Gain: 100

Measure Window Start: 300ms

Measure Window Length: 1000ms

BWC applied: 0.16 dB

Device Reference Point: 0, 0, -6.3 mm

Cursor:

ABM1/ABM2 = 45.41 dB

ABM1 comp = -1.85 dBA/m

BWC Factor = 0.16 dB

Location: 4.5, -10, 3.7 mm

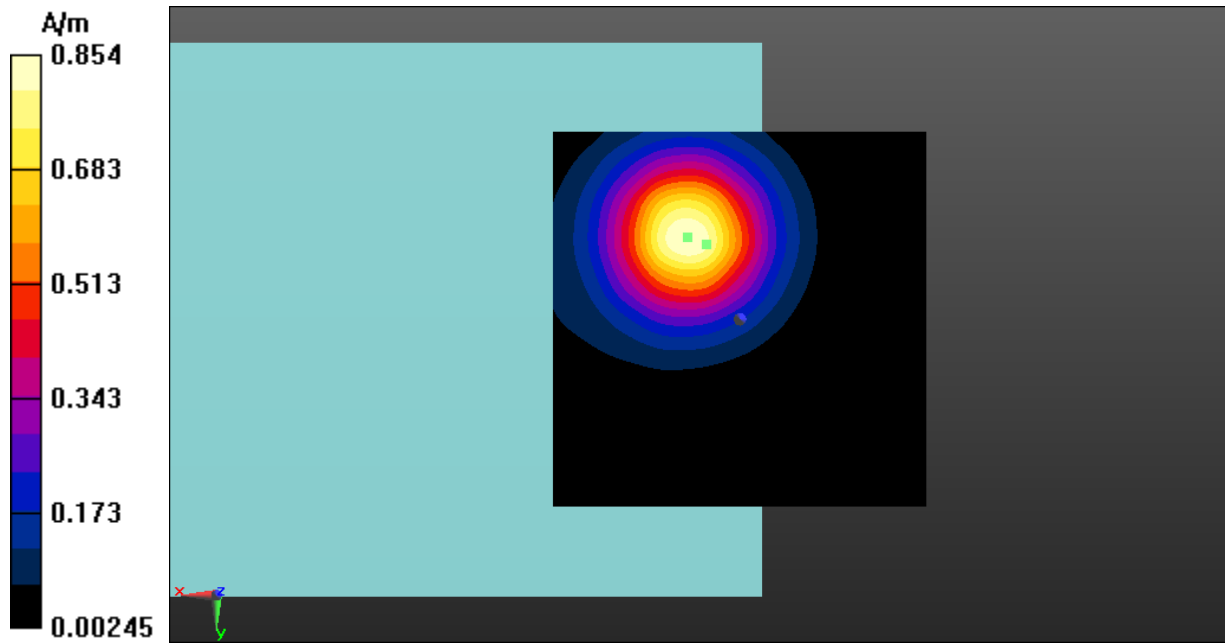

Fig A.20 T-Coil LTE-Band 26-Z



T-Coil LTE-Band 26 Transverse (Ant.2)

Date: 2023-2-9

Electronics: DAE4 Sn786

Medium: Air

Medium parameters used: $\sigma = 0$ S/m, $\epsilon_r = 1$; $\rho = 1$ kg/m³

Communication System: UID 0, LTE_FDD (0) Frequency: 831.5 MHz Duty Cycle: 1:1

Probe: AM1DV3 - 3086

y (transversal) 4.2mm 50 x 50/ABM Interpolated Signal(x,y,z) (101x101x1): Interpolated grid:

dx=1.000 mm, dy=1.000 mm

Signal Type: Audio File (.wav) 48k_voice_1kHz_1s.wav

Output Gain: 100

Measure Window Start: 300ms

Measure Window Length: 1000ms

BWC applied: 0.16 dB

Device Reference Point: 0, 0, -6.3 mm

Cursor:

ABM1 = -11.01 dBA/m

BWC Factor = 0.16 dB

Location: 4, -21.5, 3.7 mm

y (transversal) 4.2mm 50 x 50/ABM Interpolated SNR(x,y,z) (101x101x1): Interpolated grid:

dx=1.000 mm, dy=1.000 mm

Signal Type: Audio File (.wav) 48k_voice_1kHz_1s.wav

Output Gain: 100

Measure Window Start: 300ms

Measure Window Length: 1000ms

BWC applied: 0.16 dB

Device Reference Point: 0, 0, -6.3 mm

Cursor:

ABM1/ABM2 = 38.17 dB

ABM1 comp = -12.72 dBA/m

BWC Factor = 0.16 dB

Location: -2, -2.5, 3.7 mm

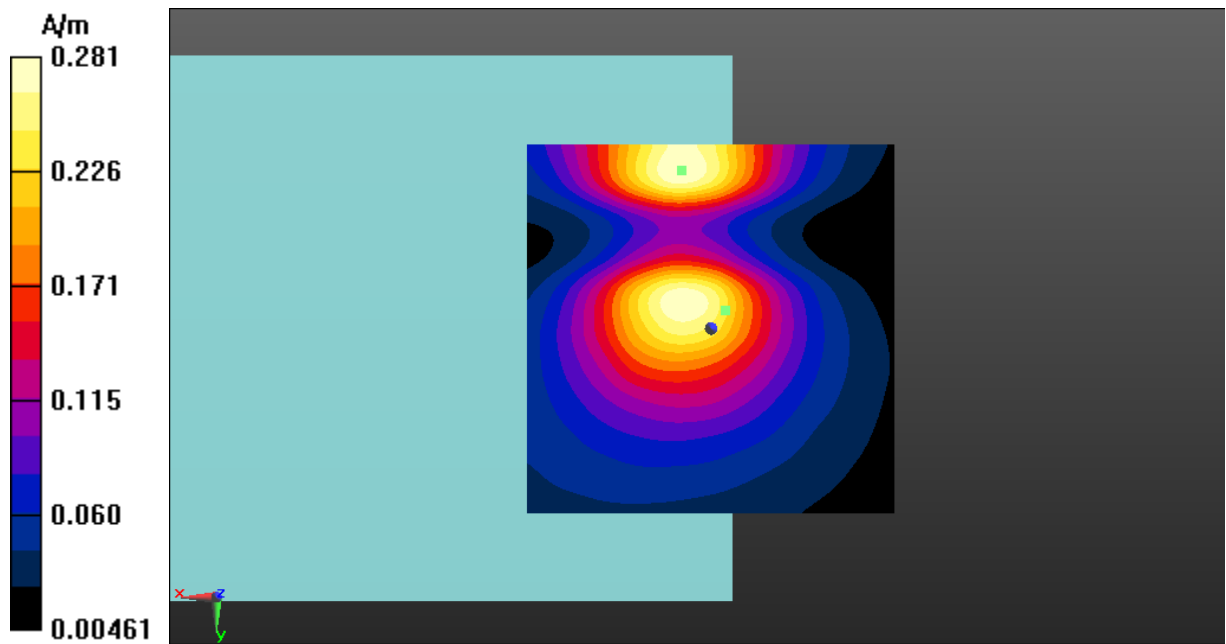

Fig A.20 T-Coil LTE-Band 26-Y



T-Coil LTE-Band 66 Axial (Ant.0)

Date: 2023-2-9

Electronics: DAE4 Sn786

Medium: Air

Medium parameters used: $\sigma = 0$ S/m, $\epsilon_r = 1$; $\rho = 1$ kg/m³

Communication System: UID 0, LTE_FDD (0) Frequency: 1745 MHz Duty Cycle: 1:1

Probe: AM1DV3 - 3086

z (axial) 4.2mm 50 x 50/ABM Interpolated Signal(x,y,z) (101x101x1): Interpolated grid:

dx=1.000 mm, dy=1.000 mm

Signal Type: Audio File (.wav) 48k_voice_1kHz_1s.wav

Output Gain: 100

Measure Window Start: 300ms

Measure Window Length: 1000ms

BWC applied: 0.16 dB

Device Reference Point: 0, 0, -6.3 mm

Cursor:

ABM1 = -1.31 dBA/m

BWC Factor = 0.16 dB

Location: 7, -10.5, 3.7 mm

z (axial) 4.2mm 50 x 50/ABM Interpolated SNR(x,y,z) (101x101x1): Interpolated grid: dx=1.000

mm, dy=1.000 mm

Signal Type: Audio File (.wav) 48k_voice_1kHz_1s.wav

Output Gain: 100

Measure Window Start: 300ms

Measure Window Length: 1000ms

BWC applied: 0.16 dB

Device Reference Point: 0, 0, -6.3 mm

Cursor:

ABM1/ABM2 = 46.46 dB

ABM1 comp = -1.59 dBA/m

BWC Factor = 0.16 dB

Location: 5, -10.5, 3.7 mm

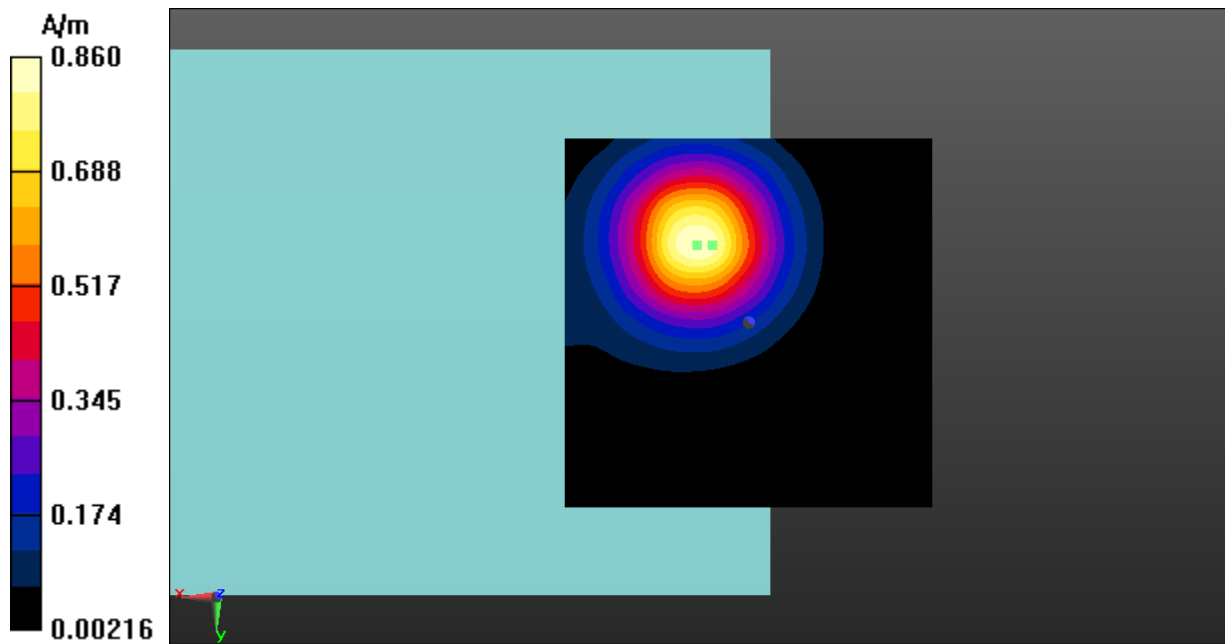

Fig A.21 T-Coil LTE-Band 66-Z



T-Coil LTE-Band 66 Transverse (Ant.0)

Date: 2023-2-9

Electronics: DAE4 Sn786

Medium: Air

Medium parameters used: $\sigma = 0$ S/m, $\epsilon_r = 1$; $\rho = 1$ kg/m³

Communication System: UID 0, LTE_FDD (0) Frequency: 1745 MHz Duty Cycle: 1:1

Probe: AM1DV3 - 3086

y (transversal) 4.2mm 50 x 50/ABM Interpolated Signal(x,y,z) (101x101x1): Interpolated grid:

dx=1.000 mm, dy=1.000 mm

Signal Type: Audio File (.wav) 48k_voice_1kHz_1s.wav

Output Gain: 100

Measure Window Start: 300ms

Measure Window Length: 1000ms

BWC applied: 0.16 dB

Device Reference Point: 0, 0, -6.3 mm

Cursor:

ABM1 = -11.09 dBA/m

BWC Factor = 0.16 dB

Location: 4, -3.5, 3.7 mm

y (transversal) 4.2mm 50 x 50/ABM Interpolated SNR(x,y,z) (101x101x1): Interpolated grid:

dx=1.000 mm, dy=1.000 mm

Signal Type: Audio File (.wav) 48k_voice_1kHz_1s.wav

Output Gain: 100

Measure Window Start: 300ms

Measure Window Length: 1000ms

BWC applied: 0.16 dB

Device Reference Point: 0, 0, -6.3 mm

Cursor:

ABM1/ABM2 = 36.88 dB

ABM1 comp = -12.32 dBA/m

BWC Factor = 0.16 dB

Location: -1, -4, 3.7 mm

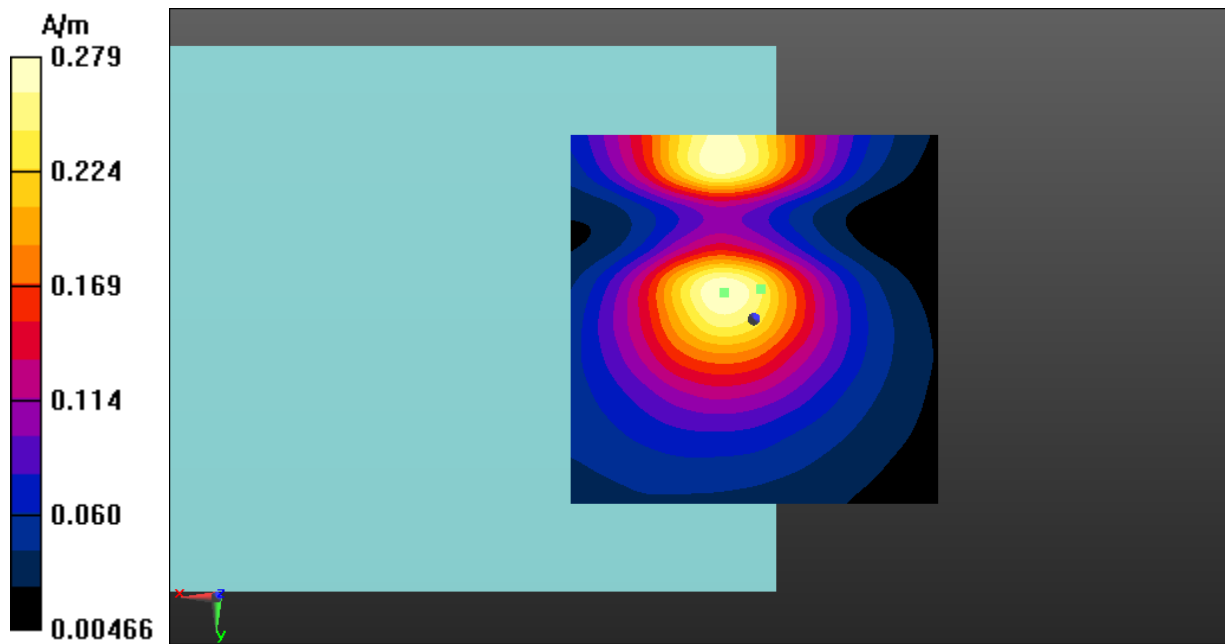

Fig A.21 T-Coil LTE-Band 66-Y



T-Coil LTE-Band 66 Axial (Ant.2)

Date: 2023-2-9

Electronics: DAE4 Sn786

Medium: Air

Medium parameters used: $\sigma = 0$ S/m, $\epsilon_r = 1$; $\rho = 1$ kg/m³

Communication System: UID 0, LTE_FDD (0) Frequency: 1745 MHz Duty Cycle: 1:1

Probe: AM1DV3 - 3086

z (axial) 4.2mm 50 x 50/ABM Interpolated Signal(x,y,z) (101x101x1): Interpolated grid:

dx=1.000 mm, dy=1.000 mm

Signal Type: Audio File (.wav) 48k_voice_1kHz_1s.wav

Output Gain: 100

Measure Window Start: 300ms

Measure Window Length: 1000ms

BWC applied: 0.16 dB

Device Reference Point: 0, 0, -6.3 mm

Cursor:

ABM1 = -1.23 dBA/m

BWC Factor = 0.16 dB

Location: 7.5, -11.5, 3.7 mm

z (axial) 4.2mm 50 x 50/ABM Interpolated SNR(x,y,z) (101x101x1): Interpolated grid: dx=1.000

mm, dy=1.000 mm

Signal Type: Audio File (.wav) 48k_voice_1kHz_1s.wav

Output Gain: 100

Measure Window Start: 300ms

Measure Window Length: 1000ms

BWC applied: 0.16 dB

Device Reference Point: 0, 0, -6.3 mm

Cursor:

ABM1/ABM2 = 41.82 dB

ABM1 comp = -1.58 dBA/m

BWC Factor = 0.16 dB

Location: 5, -12, 3.7 mm

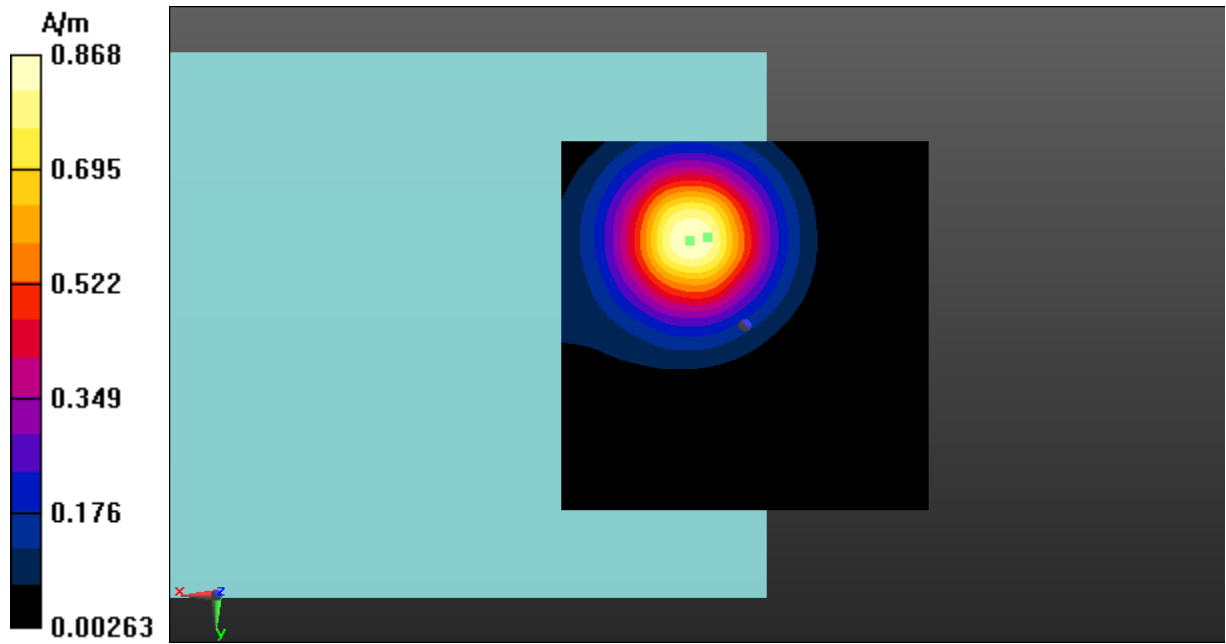

Fig A.22 T-Coil LTE-Band 66-Z



T-Coil LTE-Band 66 Transverse (Ant.2)

Date: 2023-2-9

Electronics: DAE4 Sn786

Medium: Air

Medium parameters used: $\sigma = 0$ S/m, $\epsilon_r = 1$; $\rho = 1$ kg/m³

Communication System: UID 0, LTE_FDD (0) Frequency: 1745 MHz Duty Cycle: 1:1

Probe: AM1DV3 - 3086

y (transversal) 4.2mm 50 x 50/ABM Interpolated Signal(x,y,z) (101x101x1): Interpolated grid:

dx=1.000 mm, dy=1.000 mm

Signal Type: Audio File (.wav) 48k_voice_1kHz_1s.wav

Output Gain: 100

Measure Window Start: 300ms

Measure Window Length: 1000ms

BWC applied: 0.16 dB

Device Reference Point: 0, 0, -6.3 mm

Cursor:

ABM1 = -10.82 dBA/m

BWC Factor = 0.16 dB

Location: 4.5, -4, 3.7 mm

y (transversal) 4.2mm 50 x 50/ABM Interpolated SNR(x,y,z) (101x101x1): Interpolated grid:

dx=1.000 mm, dy=1.000 mm

Signal Type: Audio File (.wav) 48k_voice_1kHz_1s.wav

Output Gain: 100

Measure Window Start: 300ms

Measure Window Length: 1000ms

BWC applied: 0.16 dB

Device Reference Point: 0, 0, -6.3 mm

Cursor:

ABM1/ABM2 = 32.13 dB

ABM1 comp = -12.41 dBA/m

BWC Factor = 0.16 dB

Location: -1.5, -4.5, 3.7 mm

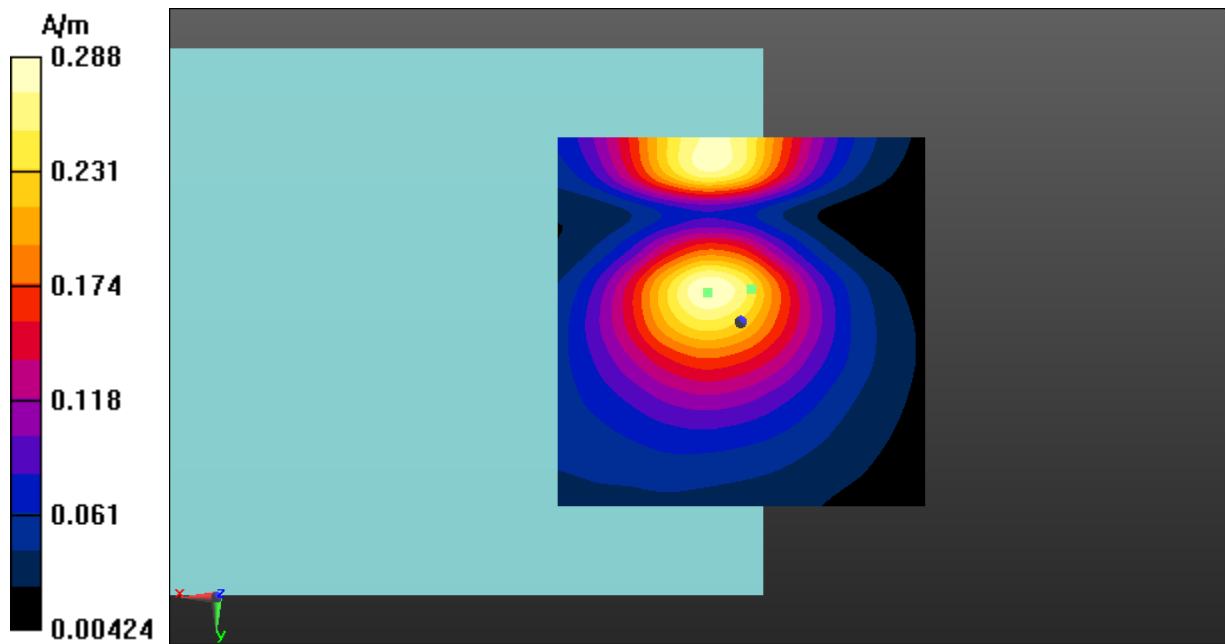

Fig A.22 T-Coil LTE-Band 66-Y



T-Coil LTE-Band 71 Axial (Ant.1)

Date: 2023-2-9

Electronics: DAE4 Sn786

Medium: Air

Medium parameters used: $\sigma = 0$ S/m, $\epsilon_r = 1$; $\rho = 1$ kg/m³

Communication System: UID 0, LTE_FDD (0) Frequency: 680.5 MHz Duty Cycle: 1:1

Probe: AM1DV3 - 3086

z (axial) 4.2mm 50 x 50/ABM Interpolated Signal(x,y,z) (101x101x1): Interpolated grid:

dx=1.000 mm, dy=1.000 mm

Signal Type: Audio File (.wav) 48k_voice_1kHz_1s.wav

Output Gain: 100

Measure Window Start: 300ms

Measure Window Length: 1000ms

BWC applied: 0.16 dB

Device Reference Point: 0, 0, -6.3 mm

Cursor:

ABM1 = -0.98 dBA/m

BWC Factor = 0.16 dB

Location: 7.5, -10, 3.7 mm

z (axial) 4.2mm 50 x 50/ABM Interpolated SNR(x,y,z) (101x101x1): Interpolated grid: dx=1.000 mm, dy=1.000 mm

Signal Type: Audio File (.wav) 48k_voice_1kHz_1s.wav

Output Gain: 100

Measure Window Start: 300ms

Measure Window Length: 1000ms

BWC applied: 0.16 dB

Device Reference Point: 0, 0, -6.3 mm

Cursor:

ABM1/ABM2 = 44.46 dB

ABM1 comp = -0.74 dBA/m

BWC Factor = 0.16 dB

Location: 5, -10.5, 3.7 mm

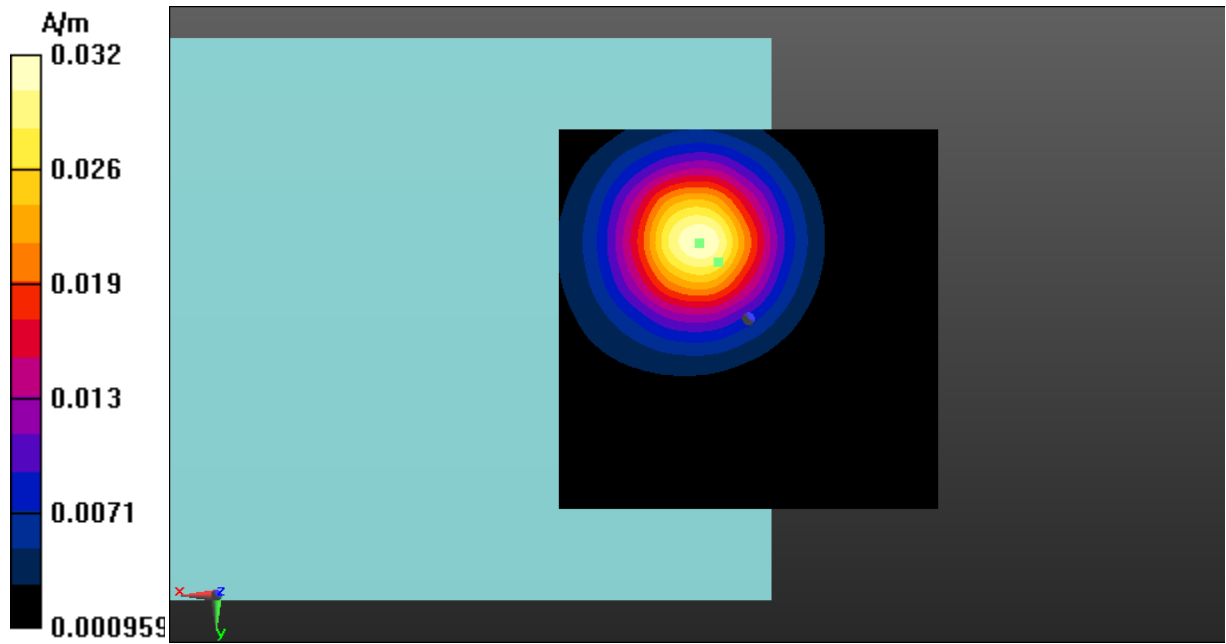

Fig A.23 T-Coil LTE-Band 71-Z



T-Coil LTE-Band 71 Transverse (Ant.1)

Date: 2023-2-9

Electronics: DAE4 Sn786

Medium: Air

Medium parameters used: $\sigma = 0$ S/m, $\epsilon_r = 1$; $\rho = 1$ kg/m³

Communication System: UID 0, LTE_FDD (0) Frequency: 680.5 MHz Duty Cycle: 1:1

Probe: AM1DV3 - 3086

y (transversal) 4.2mm 50 x 50/ABM Interpolated Signal(x,y,z) (101x101x1): Interpolated grid:

dx=1.000 mm, dy=1.000 mm

Signal Type: Audio File (.wav) 48k_voice_1kHz_1s.wav

Output Gain: 100

Measure Window Start: 300ms

Measure Window Length: 1000ms

BWC applied: 0.16 dB

Device Reference Point: 0, 0, -6.3 mm

Cursor:

ABM1 = -9.74 dBA/m

BWC Factor = 0.16 dB

Location: 4.5, -21, 3.7 mm

y (transversal) 4.2mm 50 x 50/ABM Interpolated SNR(x,y,z) (101x101x1): Interpolated grid:

dx=1.000 mm, dy=1.000 mm

Signal Type: Audio File (.wav) 48k_voice_1kHz_1s.wav

Output Gain: 100

Measure Window Start: 300ms

Measure Window Length: 1000ms

BWC applied: 0.16 dB

Device Reference Point: 0, 0, -6.3 mm

Cursor:

ABM1/ABM2 = 33.56 dB

ABM1 comp = -12.24 dBA/m

BWC Factor = 0.16 dB

Location: 0, -21.5, 3.7 mm

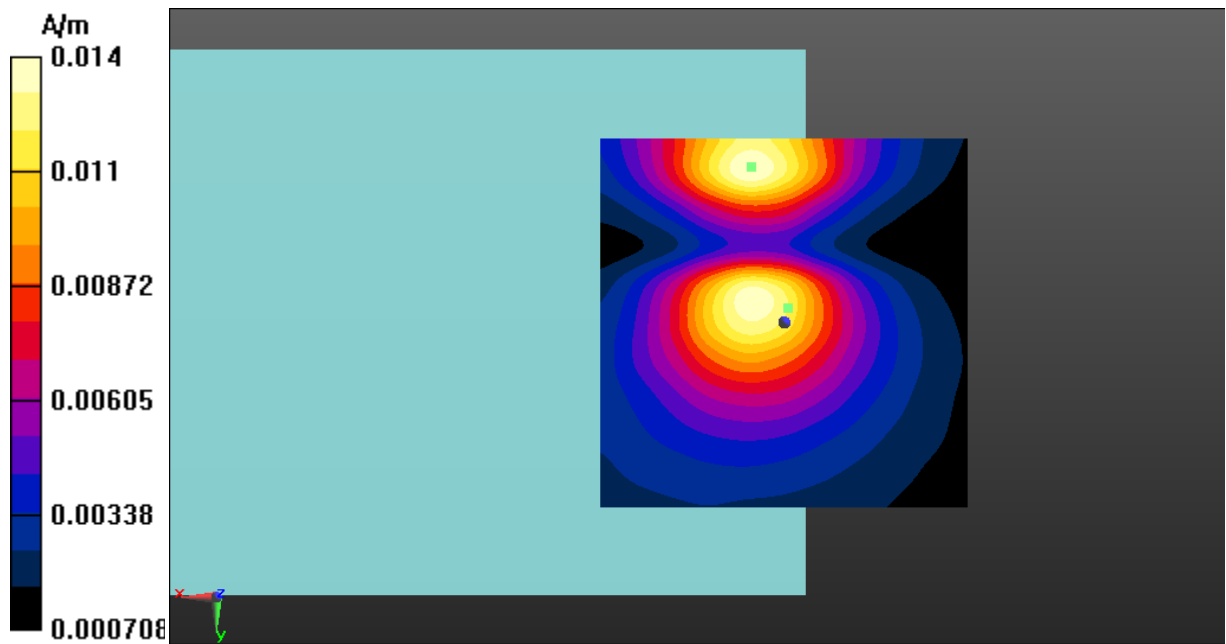

Fig A.23 T-Coil LTE-Band 71-Y



T-Coil LTE-Band 71 Axial (Ant.2)

Date: 2023-2-9

Electronics: DAE4 Sn786

Medium: Air

Medium parameters used: $\sigma = 0$ S/m, $\epsilon_r = 1$; $\rho = 1$ kg/m³

Communication System: UID 0, LTE_FDD (0) Frequency: 680.5 MHz Duty Cycle: 1:1

Probe: AM1DV3 - 3086

z (axial) 4.2mm 50 x 50/ABM Interpolated Signal(x,y,z) (101x101x1): Interpolated grid:

dx=1.000 mm, dy=1.000 mm

Signal Type: Audio File (.wav) 48k_voice_1kHz_1s.wav

Output Gain: 100

Measure Window Start: 300ms

Measure Window Length: 1000ms

BWC applied: 0.16 dB

Device Reference Point: 0, 0, -6.3 mm

Cursor:

ABM1 = -1.24 dBA/m

BWC Factor = 0.16 dB

Location: 7, -10.5, 3.7 mm

z (axial) 4.2mm 50 x 50/ABM Interpolated SNR(x,y,z) (101x101x1): Interpolated grid: dx=1.000

mm, dy=1.000 mm

Signal Type: Audio File (.wav) 48k_voice_1kHz_1s.wav

Output Gain: 100

Measure Window Start: 300ms

Measure Window Length: 1000ms

BWC applied: 0.16 dB

Device Reference Point: 0, 0, -6.3 mm

Cursor:

ABM1/ABM2 = 48.16 dB

ABM1 comp = -1.72 dBA/m

BWC Factor = 0.16 dB

Location: 4.5, -10.5, 3.7 mm

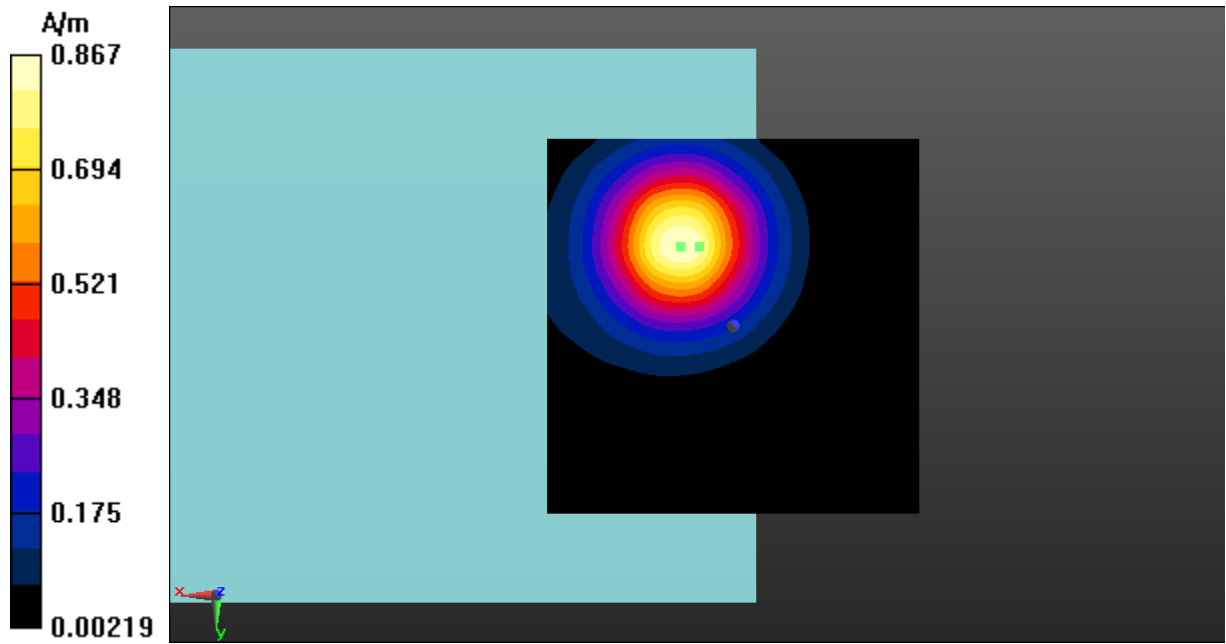

Fig A.24 T-Coil LTE-Band 71-Z



T-Coil LTE-Band 71 Transverse (Ant.2)

Date: 2023-2-9

Electronics: DAE4 Sn786

Medium: Air

Medium parameters used: $\sigma = 0$ S/m, $\epsilon_r = 1$; $\rho = 1$ kg/m³

Communication System: UID 0, LTE_FDD (0) Frequency: 680.5 MHz Duty Cycle: 1:1

Probe: AM1DV3 - 3086

y (transversal) 4.2mm 50 x 50/ABM Interpolated Signal(x,y,z) (101x101x1): Interpolated grid:

dx=1.000 mm, dy=1.000 mm

Signal Type: Audio File (.wav) 48k_voice_1kHz_1s.wav

Output Gain: 100

Measure Window Start: 300ms

Measure Window Length: 1000ms

BWC applied: 0.16 dB

Device Reference Point: 0, 0, -6.3 mm

Cursor:

ABM1 = -10.99 dBA/m

BWC Factor = 0.16 dB

Location: 4.5, -21.5, 3.7 mm

y (transversal) 4.2mm 50 x 50/ABM Interpolated SNR(x,y,z) (101x101x1): Interpolated grid:

dx=1.000 mm, dy=1.000 mm

Signal Type: Audio File (.wav) 48k_voice_1kHz_1s.wav

Output Gain: 100

Measure Window Start: 300ms

Measure Window Length: 1000ms

BWC applied: 0.16 dB

Device Reference Point: 0, 0, -6.3 mm

Cursor:

ABM1/ABM2 = 37.56 dB

ABM1 comp = -13.16 dBA/m

BWC Factor = 0.16 dB

Location: -2.5, -2, 3.7 mm

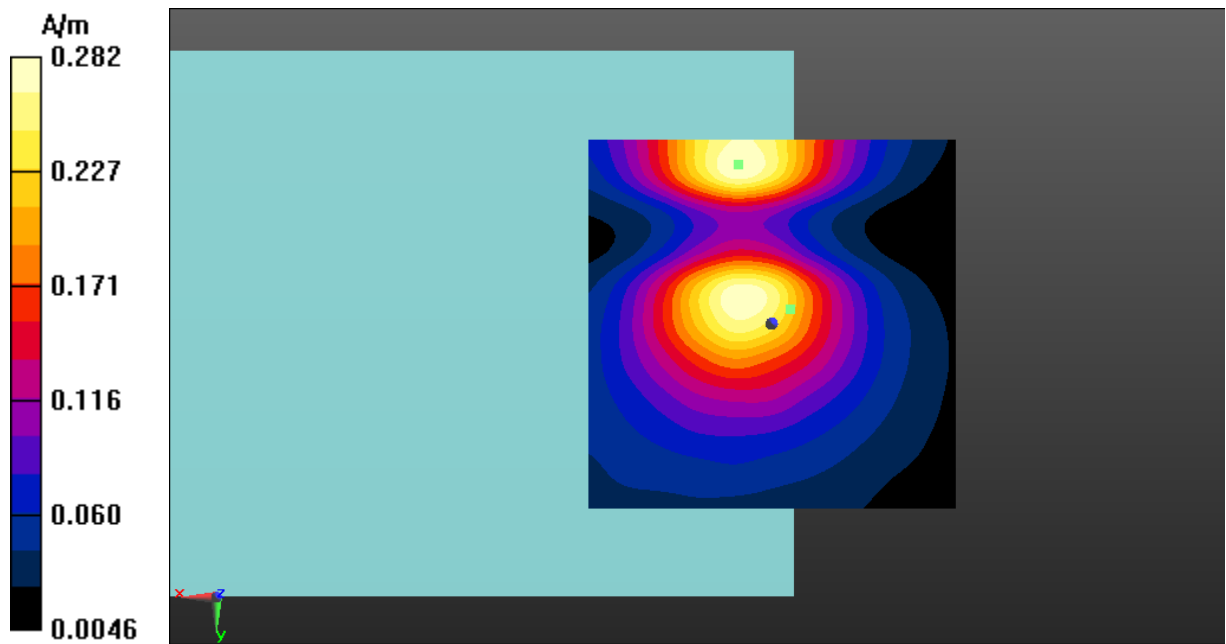

Fig A.24 T-Coil LTE-Band 71-Y



T-Coil LTE-Band 41 PC3 Axial (Ant.0)

Date: 2023-2-10

Electronics: DAE4 Sn786

Medium: Air

Medium parameters used: $\sigma = 0$ S/m, $\epsilon_r = 1$; $\rho = 1$ kg/m³

Communication System: UID 0, LTE_TDD (0) Frequency: 2593 MHz Duty Cycle: 1:1.58

Probe: AM1DV3 - 3086

z (axial) 4.2mm 50 x 50/ABM Interpolated Signal(x,y,z) (101x101x1): Interpolated grid:

dx=1.000 mm, dy=1.000 mm

Signal Type: Audio File (.wav) 48k_voice_1kHz_1s.wav

Output Gain: 100

Measure Window Start: 300ms

Measure Window Length: 1000ms

BWC applied: 0.16 dB

Device Reference Point: 0, 0, -6.3 mm

Cursor:

ABM1 = -1.35 dBA/m

BWC Factor = 0.16 dB

Location: 7.5, -11, 3.7 mm

z (axial) 4.2mm 50 x 50/ABM Interpolated SNR(x,y,z) (101x101x1): Interpolated grid: dx=1.000 mm, dy=1.000 mm

Signal Type: Audio File (.wav) 48k_voice_1kHz_1s.wav

Output Gain: 100

Measure Window Start: 300ms

Measure Window Length: 1000ms

BWC applied: 0.16 dB

Device Reference Point: 0, 0, -6.3 mm

Cursor:

ABM1/ABM2 = 36.10 dB

ABM1 comp = -2.43 dBA/m

BWC Factor = 0.16 dB

Location: 4, -10, 3.7 mm

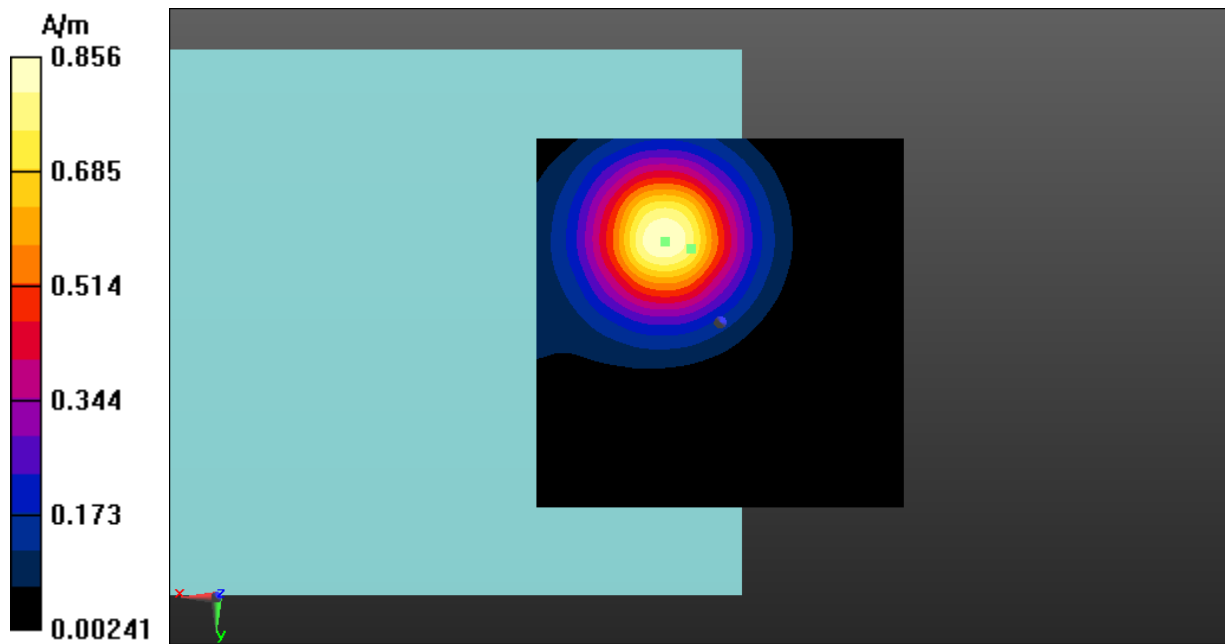

Fig A.25 T-Coil LTE-Band 41 PC3-Z



T-Coil LTE-Band 41 PC3 Axial (Ant.0)

Date: 2023-2-10

Electronics: DAE4 Sn786

Medium: Air

Medium parameters used: $\sigma = 0$ S/m, $\epsilon_r = 1$; $\rho = 1$ kg/m³

Communication System: UID 0, LTE_TDD (0) Frequency: 2593 MHz Duty Cycle: 1:1.58

Probe: AM1DV3 - 3086

y (transversal) 4.2mm 50 x 50/ABM Interpolated Signal(x,y,z) (101x101x1): Interpolated grid:

dx=1.000 mm, dy=1.000 mm

Signal Type: Audio File (.wav) 48k_voice_1kHz_1s.wav

Output Gain: 100

Measure Window Start: 300ms

Measure Window Length: 1000ms

BWC applied: 0.16 dB

Device Reference Point: 0, 0, -6.3 mm

Cursor:

ABM1 = -10.99 dBA/m

BWC Factor = 0.16 dB

Location: 4.5, -4, 3.7 mm

y (transversal) 4.2mm 50 x 50/ABM Interpolated SNR(x,y,z) (101x101x1): Interpolated grid:

dx=1.000 mm, dy=1.000 mm

Signal Type: Audio File (.wav) 48k_voice_1kHz_1s.wav

Output Gain: 100

Measure Window Start: 300ms

Measure Window Length: 1000ms

BWC applied: 0.16 dB

Device Reference Point: 0, 0, -6.3 mm

Cursor:

ABM1/ABM2 = 28.53 dB

ABM1 comp = -15.62 dBA/m

BWC Factor = 0.16 dB

Location: -3.5, 2.5, 3.7 mm

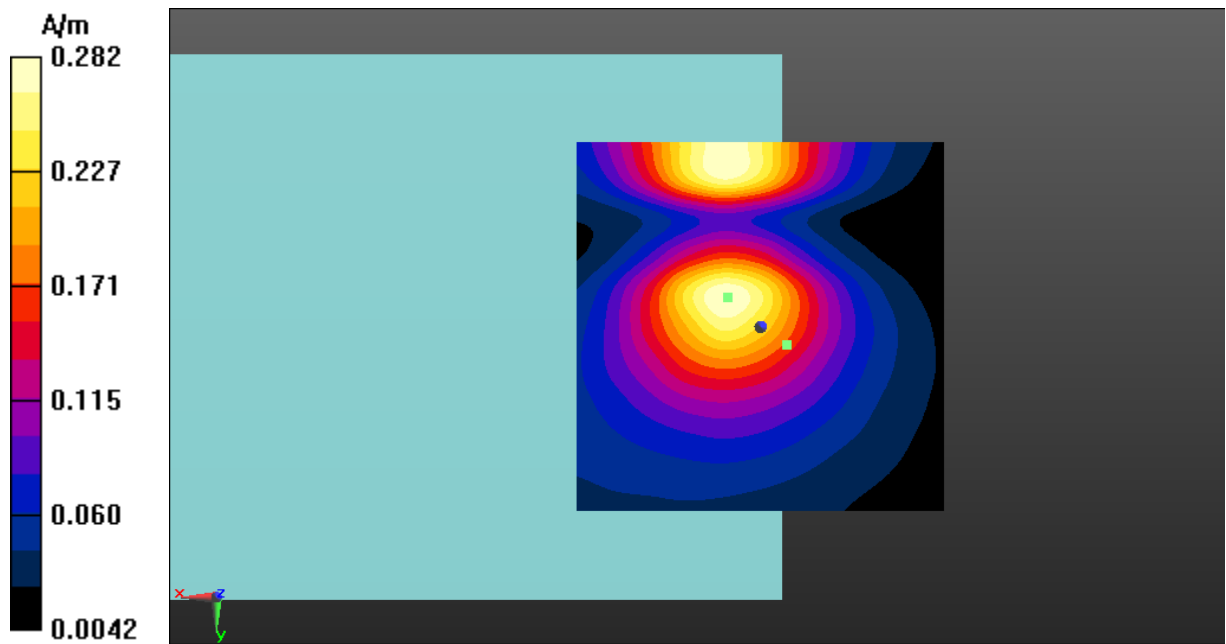

Fig A.25 T-Coil LTE-Band 41 PC3-Y



T-Coil LTE-Band 41 PC3 Axial (Ant.2)

Date: 2023-2-10

Electronics: DAE4 Sn786

Medium: Air

Medium parameters used: $\sigma = 0$ S/m, $\epsilon_r = 1$; $\rho = 1$ kg/m³

Communication System: UID 0, LTE_TDD (0) Frequency: 2593 MHz Duty Cycle: 1:1.58

Probe: AM1DV3 - 3086

z (axial) 4.2mm 50 x 50/ABM Interpolated Signal(x,y,z) (101x101x1): Interpolated grid:

dx=1.000 mm, dy=1.000 mm

Signal Type: Audio File (.wav) 48k_voice_1kHz_1s.wav

Output Gain: 100

Measure Window Start: 300ms

Measure Window Length: 1000ms

BWC applied: 0.16 dB

Device Reference Point: 0, 0, -6.3 mm

Cursor:

ABM1 = -1.00 dBA/m

BWC Factor = 0.16 dB

Location: 7, -10, 3.7 mm

z (axial) 4.2mm 50 x 50/ABM Interpolated SNR(x,y,z) (101x101x1): Interpolated grid: dx=1.000

mm, dy=1.000 mm

Signal Type: Audio File (.wav) 48k_voice_1kHz_1s.wav

Output Gain: 100

Measure Window Start: 300ms

Measure Window Length: 1000ms

BWC applied: 0.16 dB

Device Reference Point: 0, 0, -6.3 mm

Cursor:

ABM1/ABM2 = 34.92 dB

ABM1 comp = -3.80 dBA/m

BWC Factor = 0.16 dB

Location: 2.5, -6.5, 3.7 mm

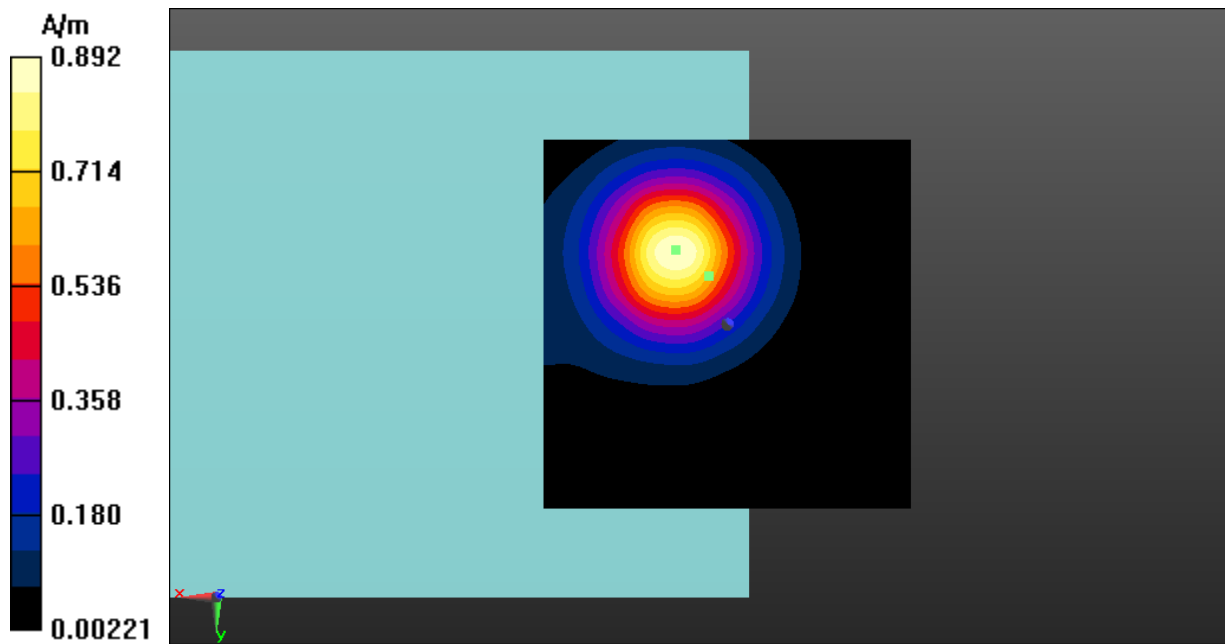

Fig A.26 T-Coil LTE-Band 41 PC3-Z



T-Coil LTE-Band 41 PC3 Axial (Ant.2)

Date: 2023-2-10

Electronics: DAE4 Sn786

Medium: Air

Medium parameters used: $\sigma = 0$ S/m, $\epsilon_r = 1$; $\rho = 1$ kg/m³

Communication System: UID 0, LTE_TDD (0) Frequency: 2593 MHz Duty Cycle: 1:1.58

Probe: AM1DV3 - 3086

y (transversal) 4.2mm 50 x 50/ABM Interpolated Signal(x,y,z) (101x101x1): Interpolated grid:

dx=1.000 mm, dy=1.000 mm

Signal Type: Audio File (.wav) 48k_voice_1kHz_1s.wav

Output Gain: 100

Measure Window Start: 300ms

Measure Window Length: 1000ms

BWC applied: 0.16 dB

Device Reference Point: 0, 0, -6.3 mm

Cursor:

ABM1 = -10.52 dBA/m

BWC Factor = 0.16 dB

Location: 4.5, -20.5, 3.7 mm

y (transversal) 4.2mm 50 x 50/ABM Interpolated SNR(x,y,z) (101x101x1): Interpolated grid:

dx=1.000 mm, dy=1.000 mm

Signal Type: Audio File (.wav) 48k_voice_1kHz_1s.wav

Output Gain: 100

Measure Window Start: 300ms

Measure Window Length: 1000ms

BWC applied: 0.16 dB

Device Reference Point: 0, 0, -6.3 mm

Cursor:

ABM1/ABM2 = 28.08 dB

ABM1 comp = -14.56 dBA/m

BWC Factor = 0.16 dB

Location: -2, 5, 3.7 mm

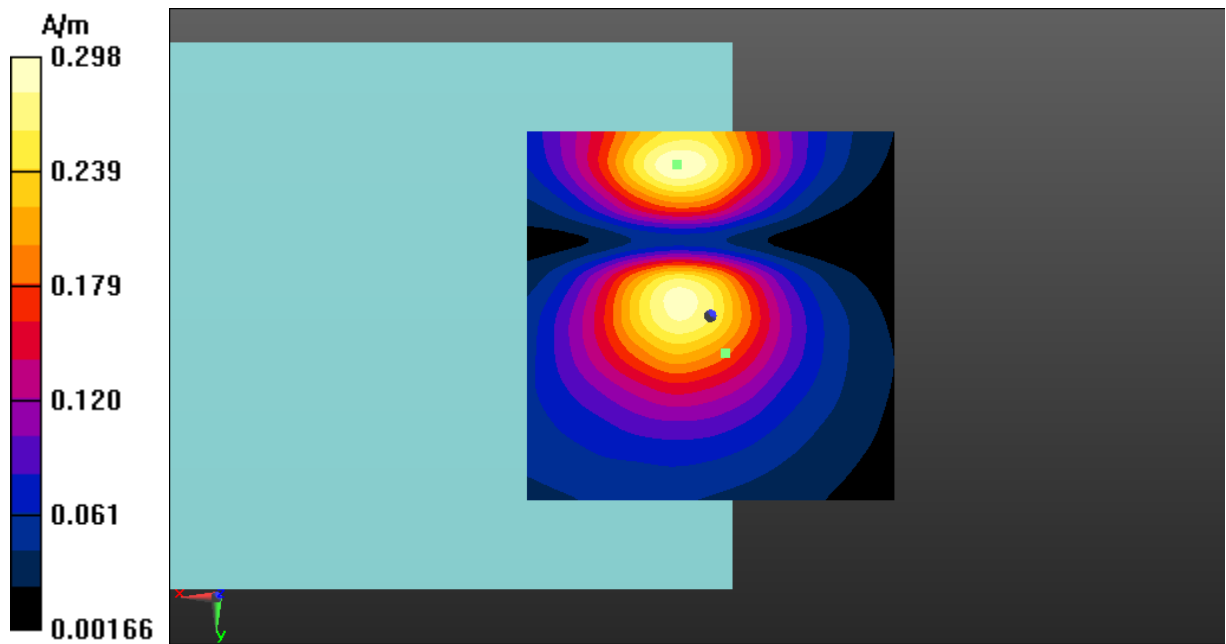

Fig A.26 T-Coil LTE-Band 41 PC3-Y



T-Coil LTE-Band 41 PC2 Axial (Ant.0)

Date: 2023-2-10

Electronics: DAE4 Sn786

Medium: Air

Medium parameters used: $\sigma = 0$ S/m, $\epsilon_r = 1$; $\rho = 1$ kg/m³

Communication System: UID 0, LTE TDD HPUE (0) Frequency: 2593 MHz Duty Cycle: 1:2.31

Probe: AM1DV3 - 3086

z (axial) 4.2mm 50 x 50/ABM Interpolated Signal(x,y,z) (101x101x1): Interpolated grid:

dx=1.000 mm, dy=1.000 mm

Signal Type: Audio File (.wav) 48k_voice_1kHz_1s.wav

Output Gain: 100

Measure Window Start: 300ms

Measure Window Length: 1000ms

BWC applied: 0.16 dB

Device Reference Point: 0, 0, -6.3 mm

Cursor:

ABM1 = -0.06 dBA/m

BWC Factor = 0.16 dB

Location: 6, -11, 3.7 mm

z (axial) 4.2mm 50 x 50/ABM Interpolated SNR(x,y,z) (101x101x1): Interpolated grid: dx=1.000 mm, dy=1.000 mm

Signal Type: Audio File (.wav) 48k_voice_1kHz_1s.wav

Output Gain: 100

Measure Window Start: 300ms

Measure Window Length: 1000ms

BWC applied: 0.16 dB

Device Reference Point: 0, 0, -6.3 mm

Cursor:

ABM1/ABM2 = 35.03 dB

ABM1 comp = -0.87 dBA/m

BWC Factor = 0.16 dB

Location: 3.5, -10, 3.7 mm

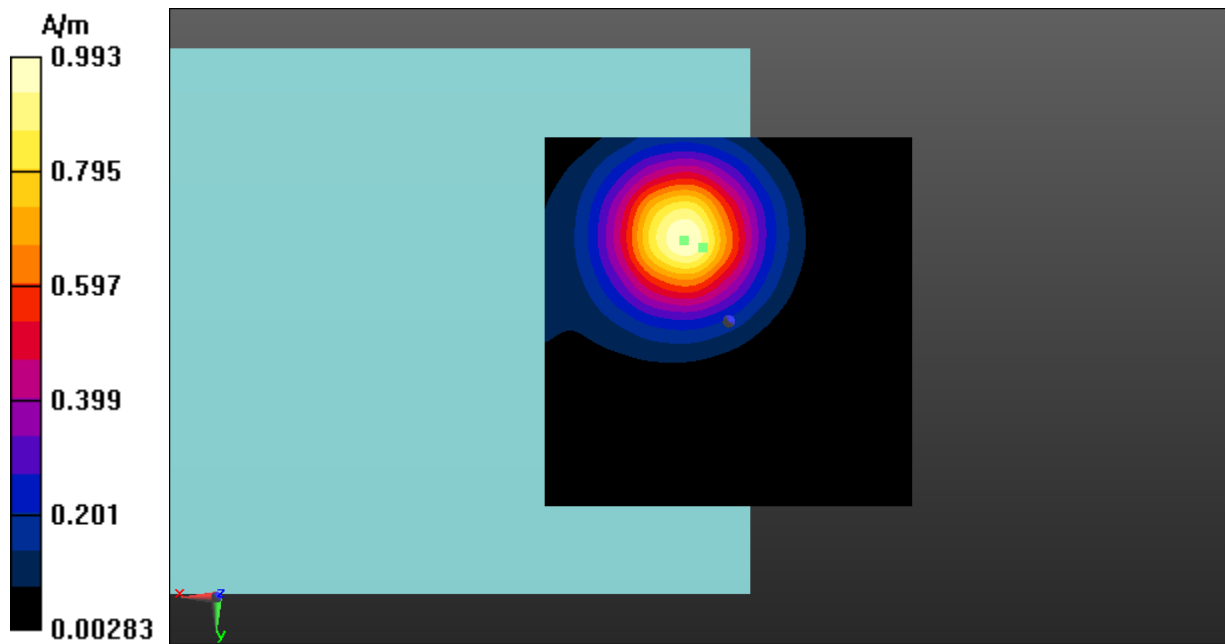

Fig A.27 T-Coil LTE-Band 41 PC2-Z



T-Coil LTE-Band 41 PC2 Axial (Ant.0)

Date: 2023-2-10

Electronics: DAE4 Sn786

Medium: Air

Medium parameters used: $\sigma = 0$ S/m, $\epsilon_r = 1$; $\rho = 1$ kg/m³

Communication System: UID 0, LTE TDD HPUE (0) Frequency: 2593 MHz Duty Cycle: 1:2.31

Probe: AM1DV3 - 3086

y (transversal) 4.2mm 50 x 50/ABM Interpolated Signal(x,y,z) (101x101x1): Interpolated grid:

dx=1.000 mm, dy=1.000 mm

Signal Type: Audio File (.wav) 48k_voice_1kHz_1s.wav

Output Gain: 100

Measure Window Start: 300ms

Measure Window Length: 1000ms

BWC applied: 0.16 dB

Device Reference Point: 0, 0, -6.3 mm

Cursor:

ABM1 = -9.36 dBA/m

BWC Factor = 0.16 dB

Location: 7.5, -19.5, 3.7 mm

y (transversal) 4.2mm 50 x 50/ABM Interpolated SNR(x,y,z) (101x101x1): Interpolated grid:

dx=1.000 mm, dy=1.000 mm

Signal Type: Audio File (.wav) 48k_voice_1kHz_1s.wav

Output Gain: 100

Measure Window Start: 300ms

Measure Window Length: 1000ms

BWC applied: 0.16 dB

Device Reference Point: 0, 0, -6.3 mm

Cursor:

ABM1/ABM2 = 27.86 dB

ABM1 comp = -11.76 dBA/m

BWC Factor = 0.16 dB

Location: 4.5, 5, 3.7 mm

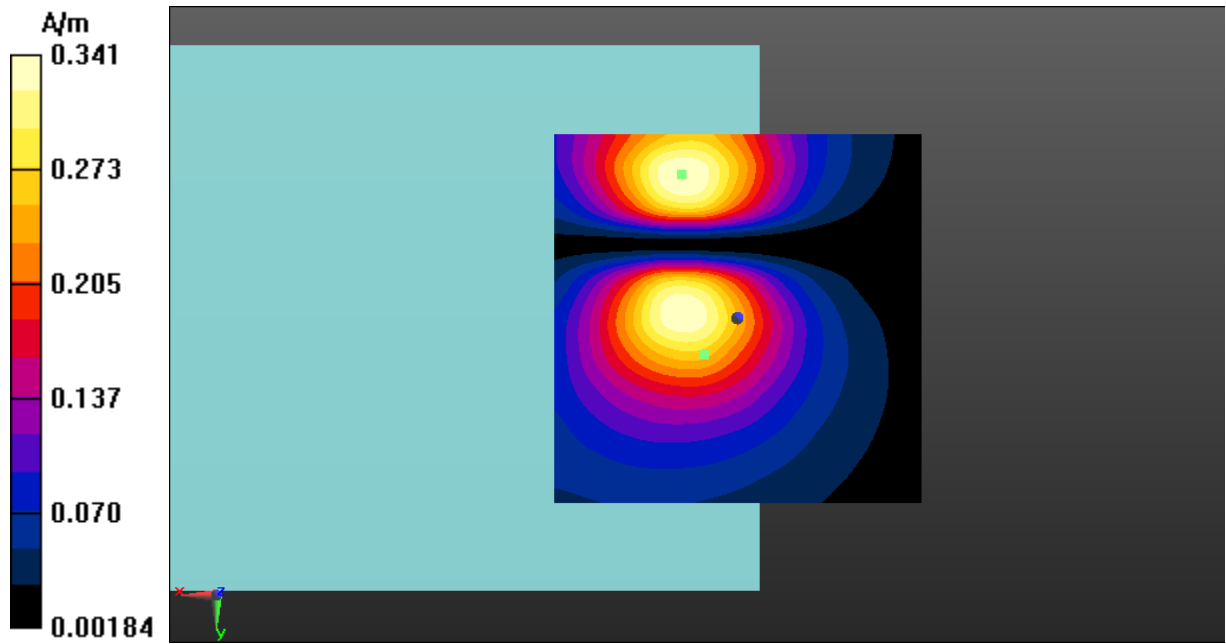

Fig A.27 T-Coil LTE-Band 41 PC2-Y



T-Coil LTE-Band 41 PC2 Axial (Ant.2)

Date: 2023-2-10

Electronics: DAE4 Sn786

Medium: Air

Medium parameters used: $\sigma = 0$ S/m, $\epsilon_r = 1$; $\rho = 1$ kg/m³

Communication System: UID 0, LTE TDD HPUE (0) Frequency: 2593 MHz Duty Cycle: 1:2.31

Probe: AM1DV3 - 3086

z (axial) 4.2mm 50 x 50/ABM Interpolated Signal(x,y,z) (101x101x1): Interpolated grid:

dx=1.000 mm, dy=1.000 mm

Signal Type: Audio File (.wav) 48k_voice_1kHz_1s.wav

Output Gain: 100

Measure Window Start: 300ms

Measure Window Length: 1000ms

BWC applied: 0.16 dB

Device Reference Point: 0, 0, -6.3 mm

Cursor:

ABM1 = -0.11 dBA/m

BWC Factor = 0.16 dB

Location: 6, -11.5, 3.7 mm

z (axial) 4.2mm 50 x 50/ABM Interpolated SNR(x,y,z) (101x101x1): Interpolated grid: dx=1.000

mm, dy=1.000 mm

Signal Type: Audio File (.wav) 48k_voice_1kHz_1s.wav

Output Gain: 100

Measure Window Start: 300ms

Measure Window Length: 1000ms

BWC applied: 0.16 dB

Device Reference Point: 0, 0, -6.3 mm

Cursor:

ABM1/ABM2 = 34.83 dB

ABM1 comp = -1.25 dBA/m

BWC Factor = 0.16 dB

Location: 3, -10, 3.7 mm

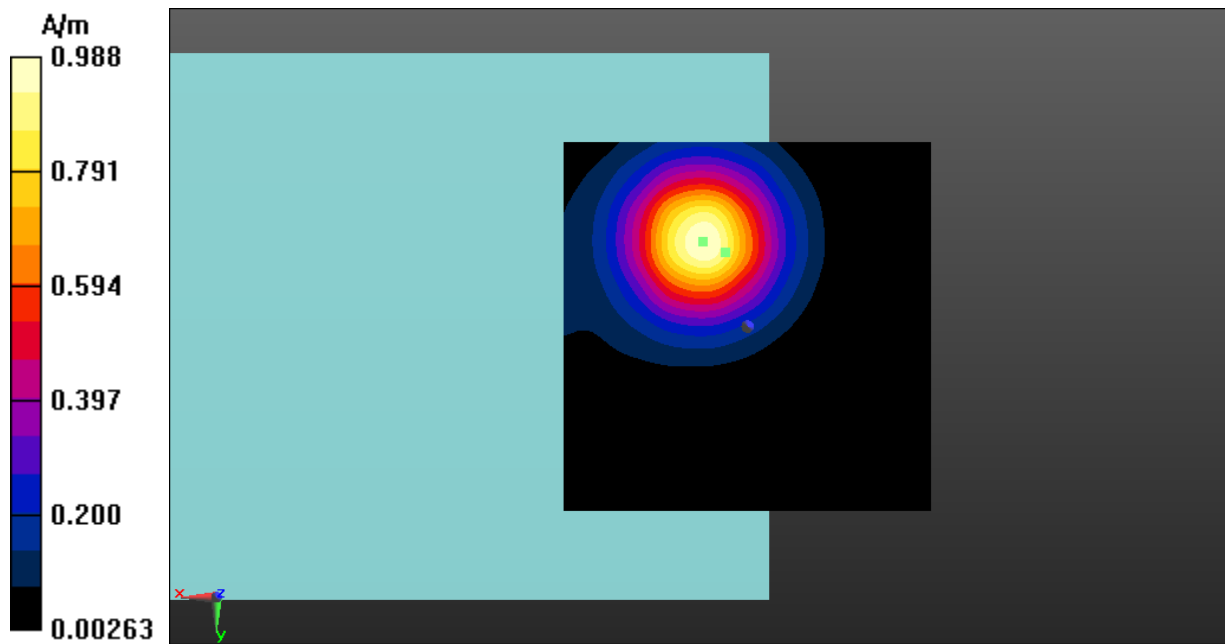

Fig A.28 T-Coil LTE-Band 41 PC2-Z



T-Coil LTE-Band 41 PC2 Axial (Ant.2)

Date: 2023-2-10

Electronics: DAE4 Sn786

Medium: Air

Medium parameters used: $\sigma = 0$ S/m, $\epsilon_r = 1$; $\rho = 1$ kg/m³

Communication System: UID 0, LTE TDD HPUE (0) Frequency: 2593 MHz Duty Cycle: 1:2.31

Probe: AM1DV3 - 3086

y (transversal) 4.2mm 50 x 50/ABM Interpolated Signal(x,y,z) (101x101x1): Interpolated grid:

dx=1.000 mm, dy=1.000 mm

Signal Type: Audio File (.wav) 48k_voice_1kHz_1s.wav

Output Gain: 100

Measure Window Start: 300ms

Measure Window Length: 1000ms

BWC applied: 0.16 dB

Device Reference Point: 0, 0, -6.3 mm

Cursor:

ABM1 = -9.20 dBA/m

BWC Factor = 0.16 dB

Location: 7.5, -0.5, 3.7 mm

y (transversal) 4.2mm 50 x 50/ABM Interpolated SNR(x,y,z) (101x101x1): Interpolated grid:

dx=1.000 mm, dy=1.000 mm

Signal Type: Audio File (.wav) 48k_voice_1kHz_1s.wav

Output Gain: 100

Measure Window Start: 300ms

Measure Window Length: 1000ms

BWC applied: 0.16 dB

Device Reference Point: 0, 0, -6.3 mm

Cursor:

ABM1/ABM2 = 27.51 dB

ABM1 comp = -11.76 dBA/m

BWC Factor = 0.16 dB

Location: 4.5, 5, 3.7 mm

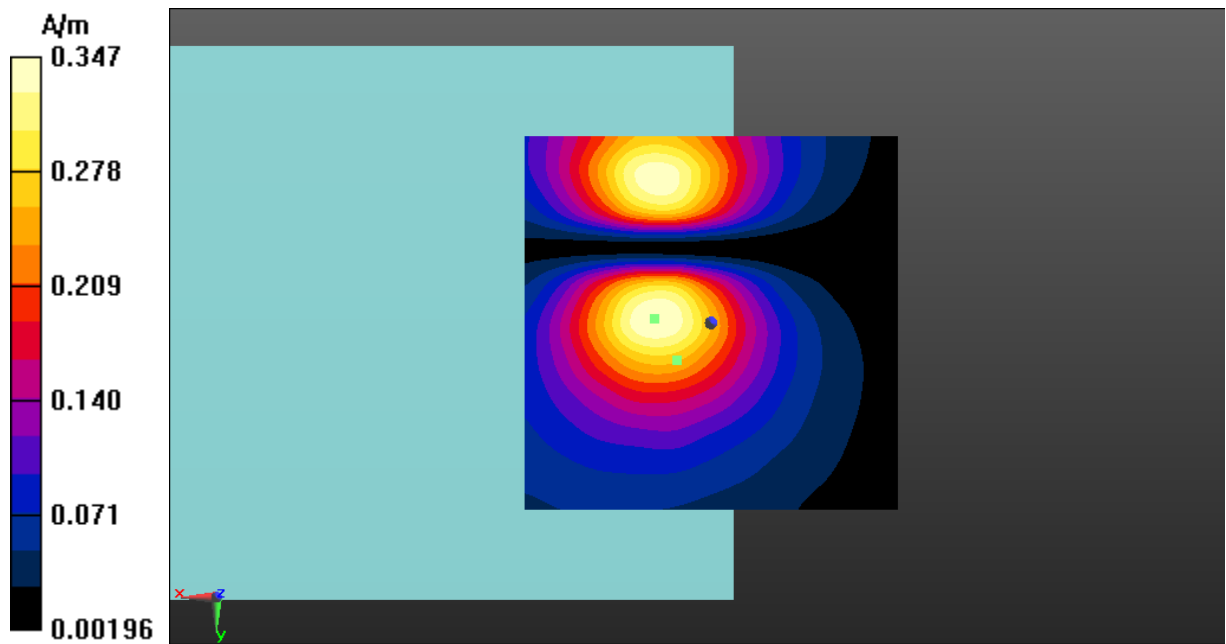

Fig A.28 T-Coil LTE-Band 41 PC2-Y



T-Coil LTE-Band 42 Axial (Ant.0)

Date: 2023-2-10

Electronics: DAE4 Sn786

Medium: Air

Medium parameters used: $\sigma = 0$ S/m, $\epsilon_r = 1$; $\rho = 1$ kg/m³

Communication System: UID 0, LTE_TDD (0) Frequency: 3500 MHz Duty Cycle: 1:1.58

Probe: AM1DV3 - 3086

z (axial) 4.2mm 50 x 50/ABM Interpolated Signal(x,y,z) (101x101x1): Interpolated grid:

dx=1.000 mm, dy=1.000 mm

Signal Type: Audio File (.wav) 48k_voice_1kHz_1s.wav

Output Gain: 100

Measure Window Start: 300ms

Measure Window Length: 1000ms

BWC applied: 0.16 dB

Device Reference Point: 0, 0, -6.3 mm

Cursor:

ABM1 = -0.22 dBA/m

BWC Factor = 0.16 dB

Location: 6.5, -11, 3.7 mm

z (axial) 4.2mm 50 x 50/ABM Interpolated SNR(x,y,z) (101x101x1): Interpolated grid: dx=1.000

mm, dy=1.000 mm

Signal Type: Audio File (.wav) 48k_voice_1kHz_1s.wav

Output Gain: 100

Measure Window Start: 300ms

Measure Window Length: 1000ms

BWC applied: 0.16 dB

Device Reference Point: 0, 0, -6.3 mm

Cursor:

ABM1/ABM2 = 40.25 dB

ABM1 comp = -4.25 dBA/m

BWC Factor = 0.16 dB

Location: 0, -12, 3.7 mm

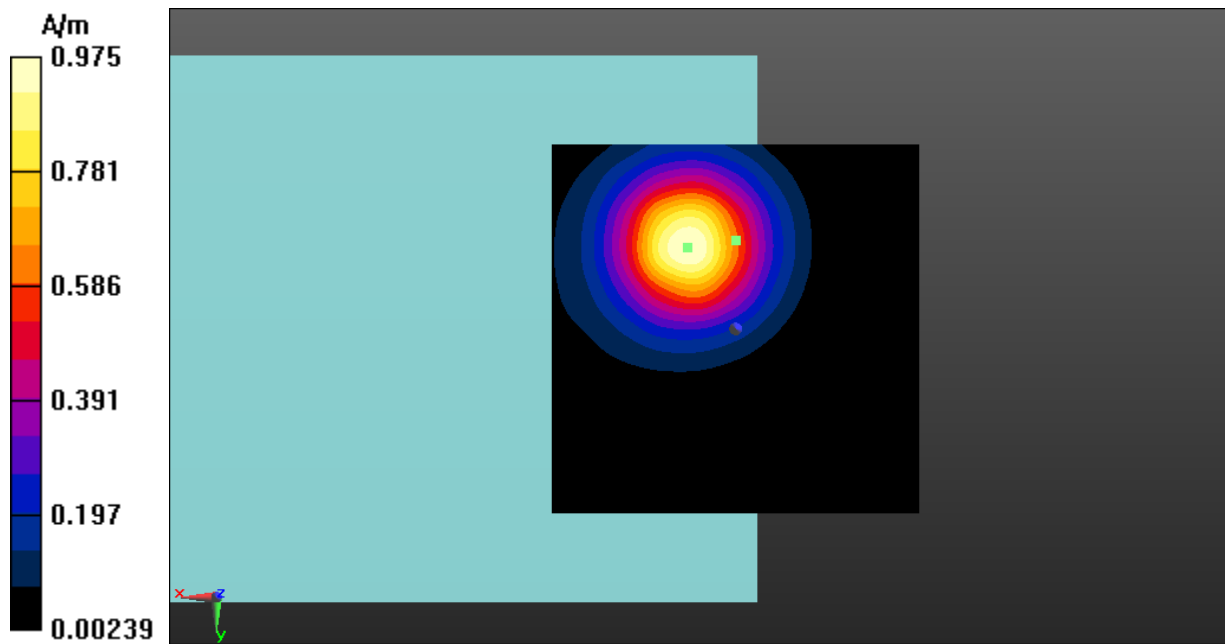

Fig A.29 T-Coil LTE-Band 42-Z



T-Coil LTE-Band 42 Axial (Ant.0)

Date: 2023-2-10

Electronics: DAE4 Sn786

Medium: Air

Medium parameters used: $\sigma = 0$ S/m, $\epsilon_r = 1$; $\rho = 1$ kg/m³

Communication System: UID 0, LTE_TDD (0) Frequency: 3500 MHz Duty Cycle: 1:1.58

Probe: AM1DV3 - 3086

y (transversal) 4.2mm 50 x 50/ABM Interpolated Signal(x,y,z) (101x101x1): Interpolated grid:

dx=1.000 mm, dy=1.000 mm

Signal Type: Audio File (.wav) 48k_voice_1kHz_1s.wav

Output Gain: 100

Measure Window Start: 300ms

Measure Window Length: 1000ms

BWC applied: 0.16 dB

Device Reference Point: 0, 0, -6.3 mm

Cursor:

ABM1 = -9.40 dBA/m

BWC Factor = 0.16 dB

Location: 8, 0, 3.7 mm

y (transversal) 4.2mm 50 x 50/ABM Interpolated SNR(x,y,z) (101x101x1): Interpolated grid:

dx=1.000 mm, dy=1.000 mm

Signal Type: Audio File (.wav) 48k_voice_1kHz_1s.wav

Output Gain: 100

Measure Window Start: 300ms

Measure Window Length: 1000ms

BWC applied: 0.16 dB

Device Reference Point: 0, 0, -6.3 mm

Cursor:

ABM1/ABM2 = 34.66 dB

ABM1 comp = -12.30 dBA/m

BWC Factor = 0.16 dB

Location: 0.5, 3, 3.7 mm

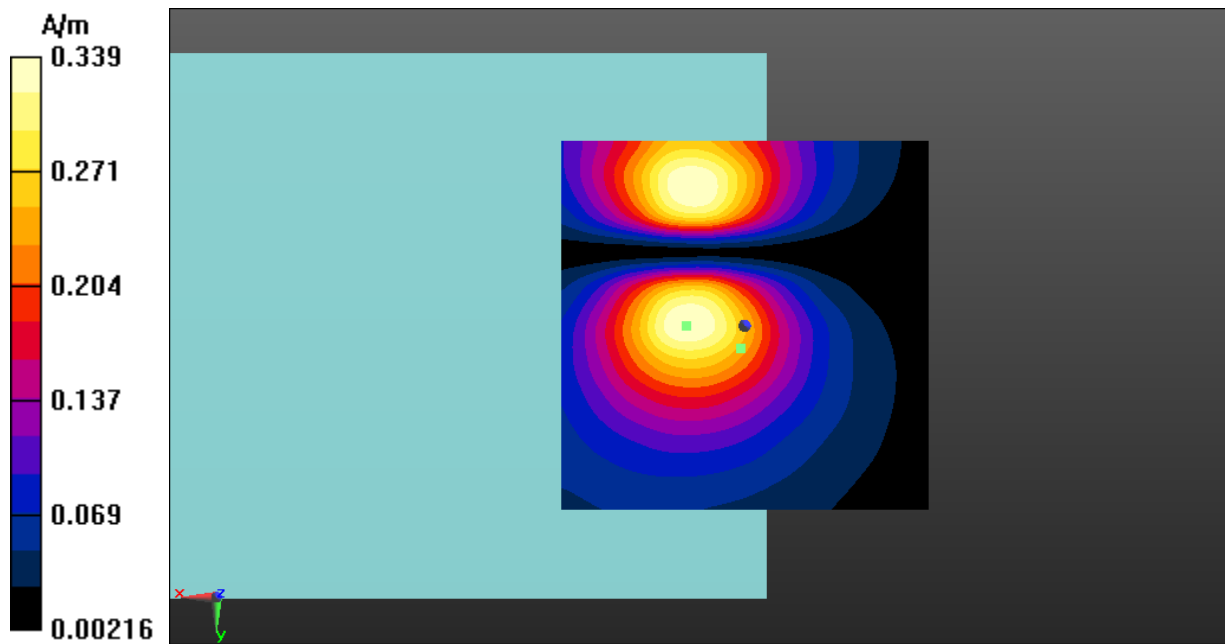

Fig A.29 T-Coil LTE-Band 42-Y



T-Coil LTE-Band 42 Axial (Ant.5)

Date: 2023-2-10

Electronics: DAE4 Sn786

Medium: Air

Medium parameters used: $\sigma = 0$ S/m, $\epsilon_r = 1$; $\rho = 1$ kg/m³

Communication System: UID 0, LTE_TDD (0) Frequency: 3500 MHz Duty Cycle: 1:1.58

Probe: AM1DV3 - 3086

z (axial) 4.2mm 50 x 50/ABM Interpolated Signal(x,y,z) (101x101x1): Interpolated grid:

dx=1.000 mm, dy=1.000 mm

Signal Type: Audio File (.wav) 48k_voice_1kHz_1s.wav

Output Gain: 100

Measure Window Start: 300ms

Measure Window Length: 1000ms

BWC applied: 0.16 dB

Device Reference Point: 0, 0, -6.3 mm

Cursor:

ABM1 = -0.19 dBA/m

BWC Factor = 0.16 dB

Location: 6, -11, 3.7 mm

z (axial) 4.2mm 50 x 50/ABM Interpolated SNR(x,y,z) (101x101x1): Interpolated grid: dx=1.000

mm, dy=1.000 mm

Signal Type: Audio File (.wav) 48k_voice_1kHz_1s.wav

Output Gain: 100

Measure Window Start: 300ms

Measure Window Length: 1000ms

BWC applied: 0.16 dB

Device Reference Point: 0, 0, -6.3 mm

Cursor:

ABM1/ABM2 = 40.65 dB

ABM1 comp = -3.82 dBA/m

BWC Factor = 0.16 dB

Location: 0, -11.5, 3.7 mm

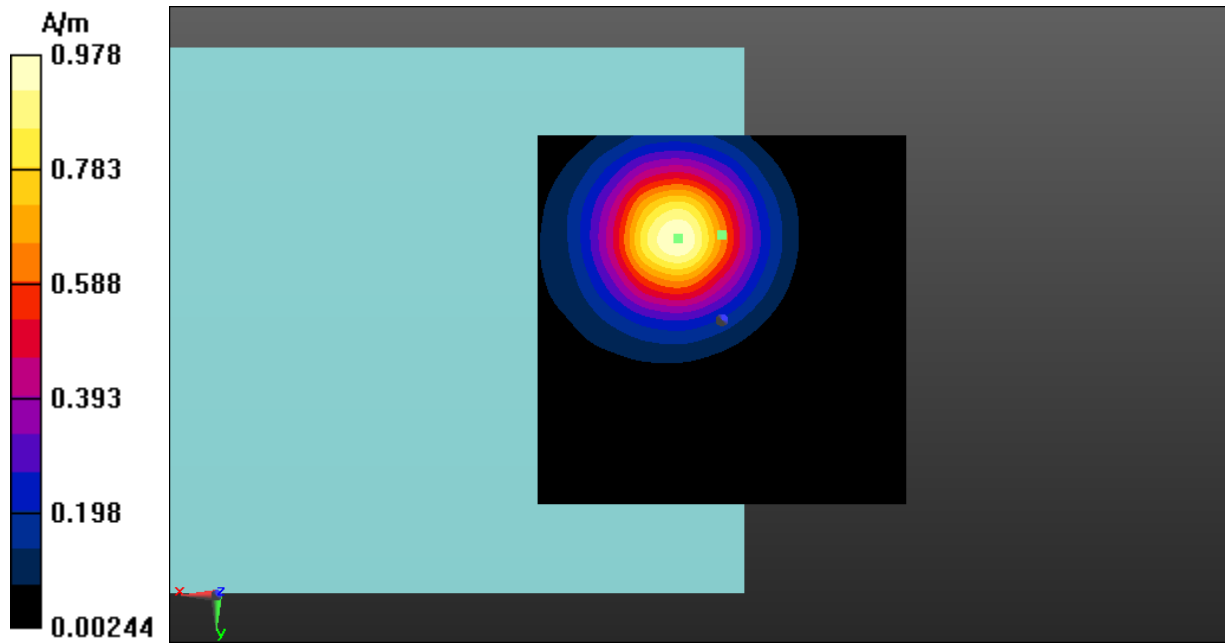

Fig A.30 T-Coil LTE-Band 42-Z



T-Coil LTE-Band 42 Axial (Ant.5)

Date: 2023-2-10

Electronics: DAE4 Sn786

Medium: Air

Medium parameters used: $\sigma = 0$ S/m, $\epsilon_r = 1$; $\rho = 1$ kg/m³

Communication System: UID 0, LTE_TDD (0) Frequency: 3500 MHz Duty Cycle: 1:1.58

Probe: AM1DV3 - 3086

y (transversal) 4.2mm 50 x 50/ABM Interpolated Signal(x,y,z) (101x101x1): Interpolated grid:

dx=1.000 mm, dy=1.000 mm

Signal Type: Audio File (.wav) 48k_voice_1kHz_1s.wav

Output Gain: 100

Measure Window Start: 300ms

Measure Window Length: 1000ms

BWC applied: 0.16 dB

Device Reference Point: 0, 0, -6.3 mm

Cursor:

ABM1 = -9.25 dBA/m

BWC Factor = 0.16 dB

Location: 7, 0, 3.7 mm

y (transversal) 4.2mm 50 x 50/ABM Interpolated SNR(x,y,z) (101x101x1): Interpolated grid:

dx=1.000 mm, dy=1.000 mm

Signal Type: Audio File (.wav) 48k_voice_1kHz_1s.wav

Output Gain: 100

Measure Window Start: 300ms

Measure Window Length: 1000ms

BWC applied: 0.16 dB

Device Reference Point: 0, 0, -6.3 mm

Cursor:

ABM1/ABM2 = 34.82 dB

ABM1 comp = -10.46 dBA/m

BWC Factor = 0.16 dB

Location: 3, 1.5, 3.7 mm

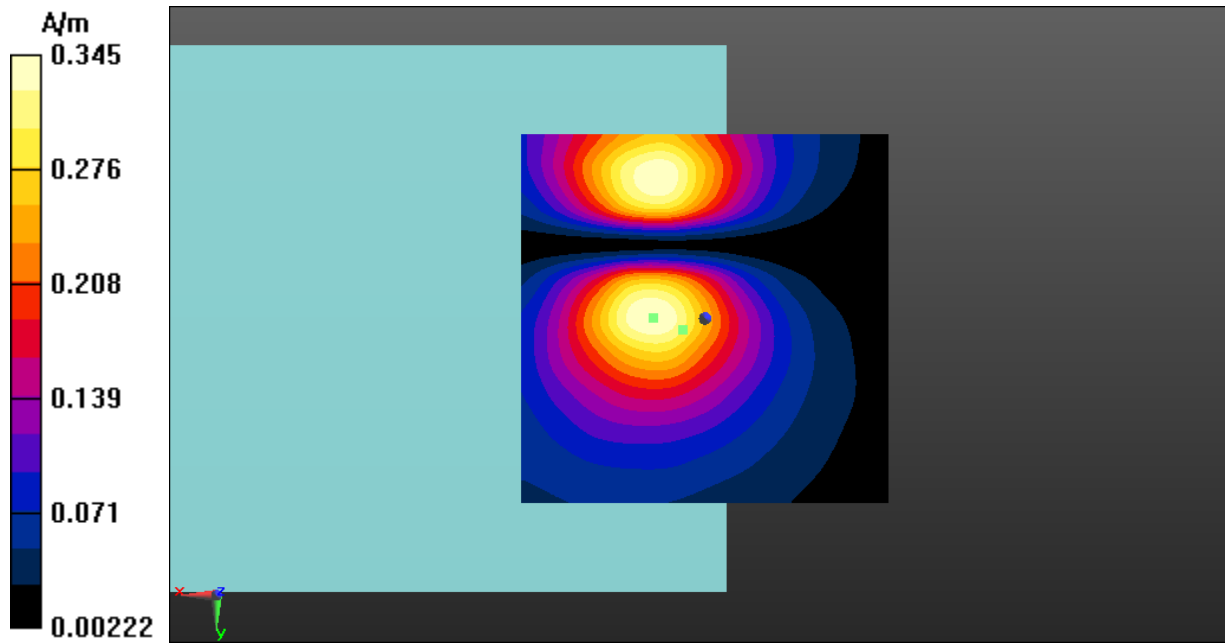

Fig A.30 T-Coil LTE-Band 42-Y



T-Coil LTE-Band 48 Axial (Ant.0)

Date: 2023-2-10

Electronics: DAE4 Sn786

Medium: Air

Medium parameters used: $\sigma = 0$ S/m, $\epsilon_r = 1$; $\rho = 1$ kg/m³

Communication System: UID 0, LTE_TDD (0) Frequency: 3625 MHz Duty Cycle: 1:1.58

Probe: AM1DV3 - 3086

z (axial) 4.2mm 50 x 50/ABM Interpolated Signal(x,y,z) (101x101x1): Interpolated grid:

dx=1.000 mm, dy=1.000 mm

Signal Type: Audio File (.wav) 48k_voice_1kHz_1s.wav

Output Gain: 100

Measure Window Start: 300ms

Measure Window Length: 1000ms

BWC applied: 0.16 dB

Device Reference Point: 0, 0, -6.3 mm

Cursor:

ABM1 = -0.22 dBA/m

BWC Factor = 0.16 dB

Location: 6, -11.5, 3.7 mm

z (axial) 4.2mm 50 x 50/ABM Interpolated SNR(x,y,z) (101x101x1): Interpolated grid: dx=1.000 mm, dy=1.000 mm

Signal Type: Audio File (.wav) 48k_voice_1kHz_1s.wav

Output Gain: 100

Measure Window Start: 300ms

Measure Window Length: 1000ms

BWC applied: 0.16 dB

Device Reference Point: 0, 0, -6.3 mm

Cursor:

ABM1/ABM2 = 41.56 dB

ABM1 comp = -3.80 dBA/m

BWC Factor = 0.16 dB

Location: 0, -12, 3.7 mm

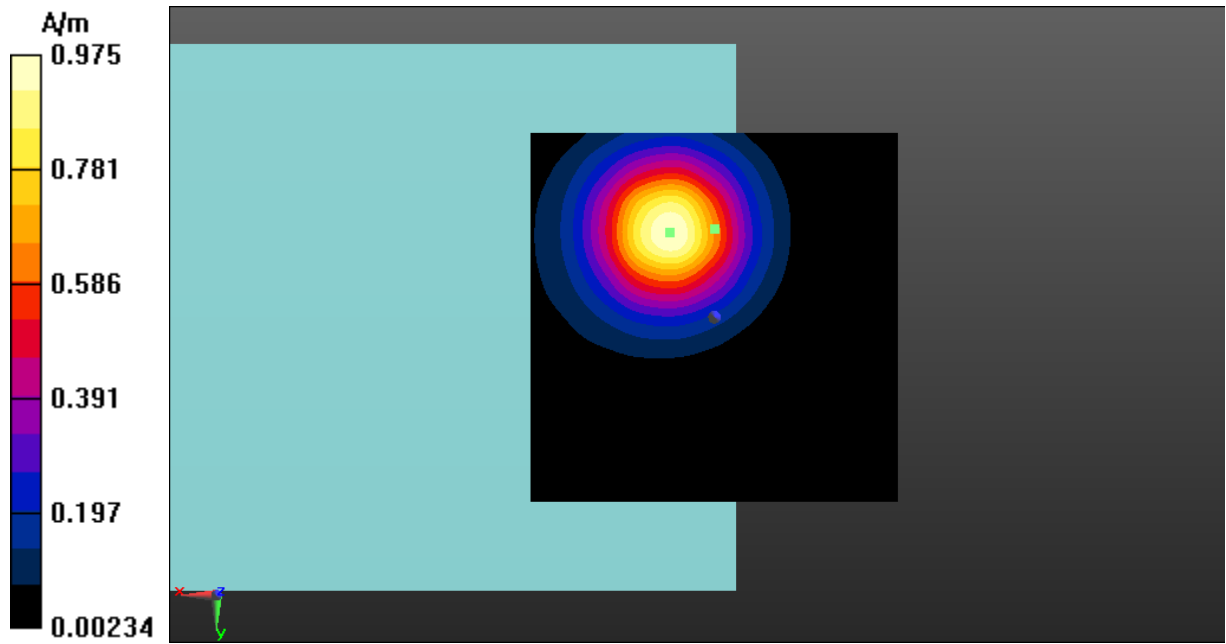

Fig A.31 T-Coil LTE-Band 48-Z



T-Coil LTE-Band 48 Axial (Ant.0)

Date: 2023-2-10

Electronics: DAE4 Sn786

Medium: Air

Medium parameters used: $\sigma = 0$ S/m, $\epsilon_r = 1$; $\rho = 1$ kg/m³

Communication System: UID 0, LTE_TDD (0) Frequency: 3625 MHz Duty Cycle: 1:1.58

Probe: AM1DV3 - 3086

y (transversal) 4.2mm 50 x 50/ABM Interpolated Signal(x,y,z) (101x101x1): Interpolated grid:

dx=1.000 mm, dy=1.000 mm

Signal Type: Audio File (.wav) 48k_voice_1kHz_1s.wav

Output Gain: 100

Measure Window Start: 300ms

Measure Window Length: 1000ms

BWC applied: 0.16 dB

Device Reference Point: 0, 0, -6.3 mm

Cursor:

ABM1 = -9.36 dBA/m

BWC Factor = 0.16 dB

Location: 7, -0.5, 3.7 mm

y (transversal) 4.2mm 50 x 50/ABM Interpolated SNR(x,y,z) (101x101x1): Interpolated grid:

dx=1.000 mm, dy=1.000 mm

Signal Type: Audio File (.wav) 48k_voice_1kHz_1s.wav

Output Gain: 100

Measure Window Start: 300ms

Measure Window Length: 1000ms

BWC applied: 0.16 dB

Device Reference Point: 0, 0, -6.3 mm

Cursor:

ABM1/ABM2 = 35.88 dB

ABM1 comp = -10.11 dBA/m

BWC Factor = 0.16 dB

Location: 3.5, 1, 3.7 mm

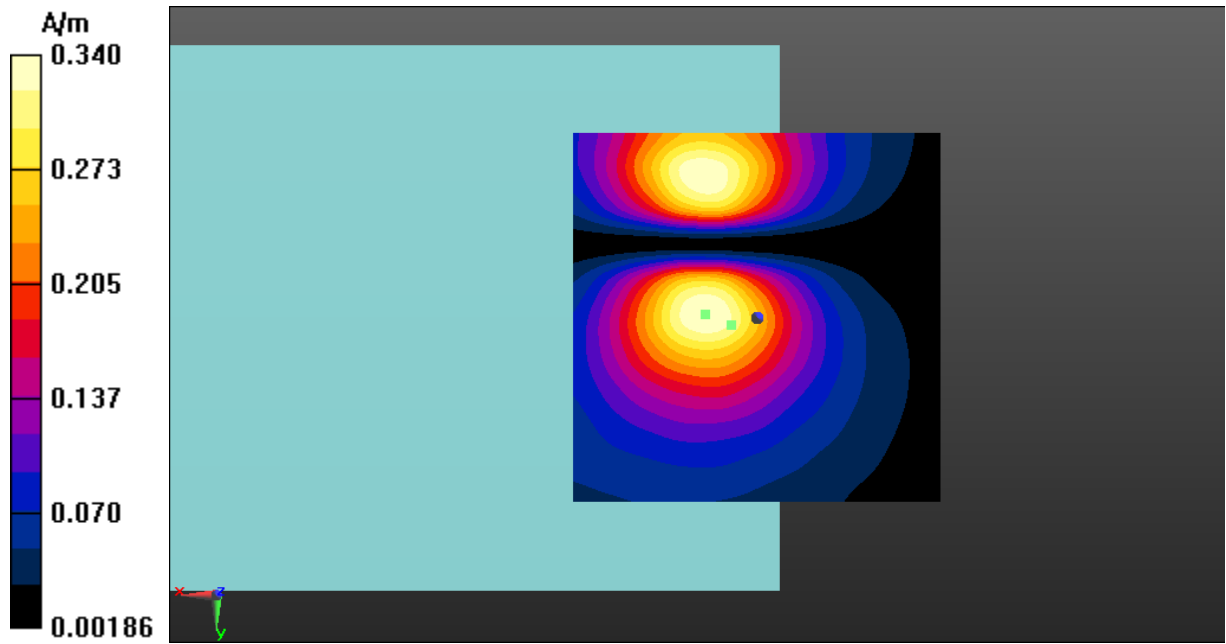

Fig A.31 T-Coil LTE-Band 48-Y



T-Coil LTE-Band 48 Axial (Ant.5)

Date: 2023-2-10

Electronics: DAE4 Sn786

Medium: Air

Medium parameters used: $\sigma = 0$ S/m, $\epsilon_r = 1$; $\rho = 1$ kg/m³

Communication System: UID 0, LTE_TDD (0) Frequency: 3625 MHz Duty Cycle: 1:1.58

Probe: AM1DV3 - 3086

z (axial) 4.2mm 50 x 50/ABM Interpolated Signal(x,y,z) (101x101x1): Interpolated grid:

dx=1.000 mm, dy=1.000 mm

Signal Type: Audio File (.wav) 48k_voice_1kHz_1s.wav

Output Gain: 100

Measure Window Start: 300ms

Measure Window Length: 1000ms

BWC applied: 0.16 dB

Device Reference Point: 0, 0, -6.3 mm

Cursor:

ABM1 = -0.31 dBA/m

BWC Factor = 0.16 dB

Location: 6, -11, 3.7 mm

z (axial) 4.2mm 50 x 50/ABM Interpolated SNR(x,y,z) (101x101x1): Interpolated grid: dx=1.000

mm, dy=1.000 mm

Signal Type: Audio File (.wav) 48k_voice_1kHz_1s.wav

Output Gain: 100

Measure Window Start: 300ms

Measure Window Length: 1000ms

BWC applied: 0.16 dB

Device Reference Point: 0, 0, -6.3 mm

Cursor:

ABM1/ABM2 = 41.32 dB

ABM1 comp = -3.23 dBA/m

BWC Factor = 0.16 dB

Location: 0.5, -11.5, 3.7 mm

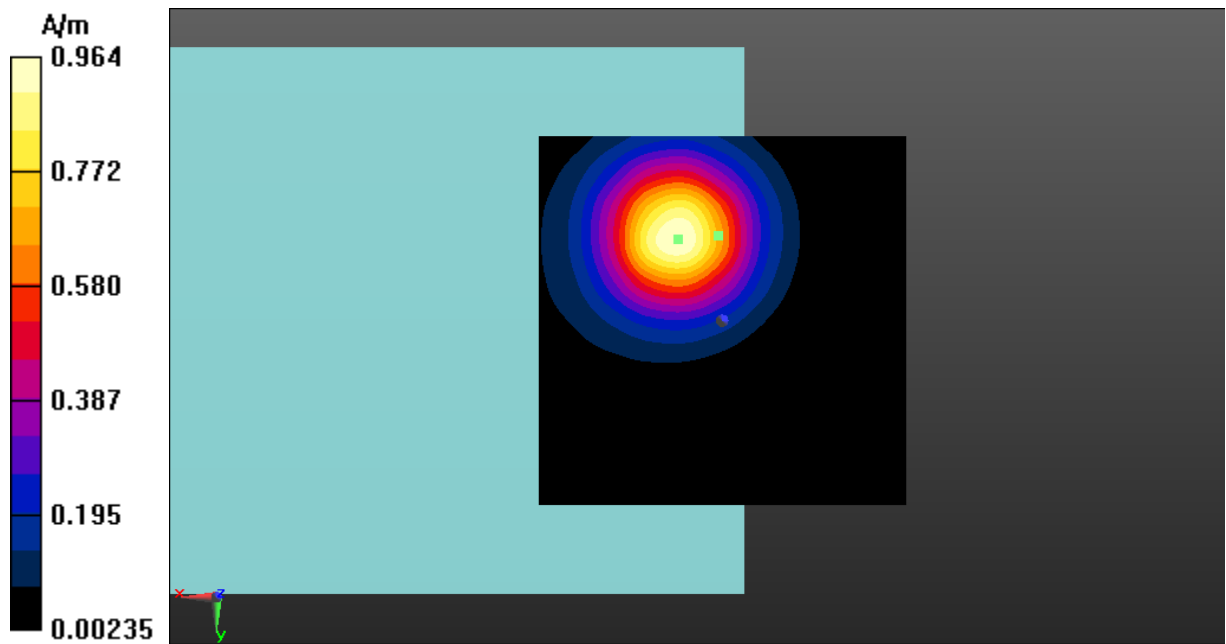

Fig A.32 T-Coil LTE-Band 48-Z



T-Coil LTE-Band 48 Axial (Ant.5)

Date: 2023-2-10

Electronics: DAE4 Sn786

Medium: Air

Medium parameters used: $\sigma = 0$ S/m, $\epsilon_r = 1$; $\rho = 1$ kg/m³

Communication System: UID 0, LTE_TDD (0) Frequency: 3625 MHz Duty Cycle: 1:1.58

Probe: AM1DV3 - 3086

y (transversal) 4.2mm 50 x 50/ABM Interpolated Signal(x,y,z) (101x101x1): Interpolated grid:

dx=1.000 mm, dy=1.000 mm

Signal Type: Audio File (.wav) 48k_voice_1kHz_1s.wav

Output Gain: 100

Measure Window Start: 300ms

Measure Window Length: 1000ms

BWC applied: 0.16 dB

Device Reference Point: 0, 0, -6.3 mm

Cursor:

ABM1 = -9.46 dBA/m

BWC Factor = 0.16 dB

Location: 7, -19.5, 3.7 mm

y (transversal) 4.2mm 50 x 50/ABM Interpolated SNR(x,y,z) (101x101x1): Interpolated grid:

dx=1.000 mm, dy=1.000 mm

Signal Type: Audio File (.wav) 48k_voice_1kHz_1s.wav

Output Gain: 100

Measure Window Start: 300ms

Measure Window Length: 1000ms

BWC applied: 0.16 dB

Device Reference Point: 0, 0, -6.3 mm

Cursor:

ABM1/ABM2 = 35.71 dB

ABM1 comp = -11.07 dBA/m

BWC Factor = 0.16 dB

Location: 2, 1, 3.7 mm

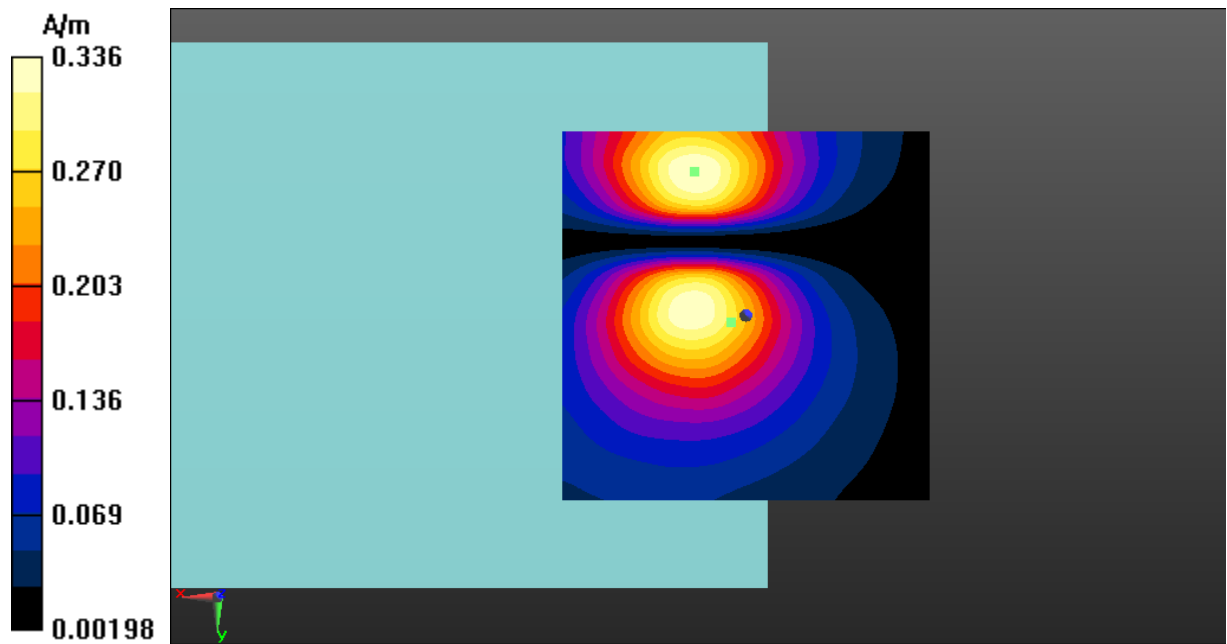

Fig A.32 T-Coil LTE-Band 48-Y



T-Coil WLAN 2.4GHz Axial

Date: 2023-1-20

Electronics: DAE4 Sn786

Medium: Air

Medium parameters used: $\sigma = 0$ S/m, $\epsilon_r = 1$; $\rho = 1$ kg/m³

Communication System: UID 0, WLAN (0) Frequency: 2437 MHz Duty Cycle: 1:1

Probe: AM1DV3 - 3086

z (axial) 4.2mm 50 x 50/ABM Interpolated Signal(x,y,z) (101x101x1): Interpolated grid:

dx=1.000 mm, dy=1.000 mm

Signal Type: Audio File (.wav) 48k_voice_1kHz_1s.wav

Output Gain: 100

Measure Window Start: 300ms

Measure Window Length: 1000ms

BWC applied: 0.16 dB

Device Reference Point: 0, 0, -6.3 mm

Cursor:

ABM1 = -4.00 dBA/m

BWC Factor = 0.16 dB

Location: 9, -10, 3.7 mm

z (axial) 4.2mm 50 x 50/ABM Interpolated SNR(x,y,z) (101x101x1): Interpolated grid: dx=1.000

mm, dy=1.000 mm

Signal Type: Audio File (.wav) 48k_voice_1kHz_1s.wav

Output Gain: 100

Measure Window Start: 300ms

Measure Window Length: 1000ms

BWC applied: 0.16 dB

Device Reference Point: 0, 0, -6.3 mm

Cursor:

ABM1/ABM2 = 43.18 dB

ABM1 comp = -5.59 dBA/m

BWC Factor = 0.16 dB

Location: 4.5, -15, 3.7 mm

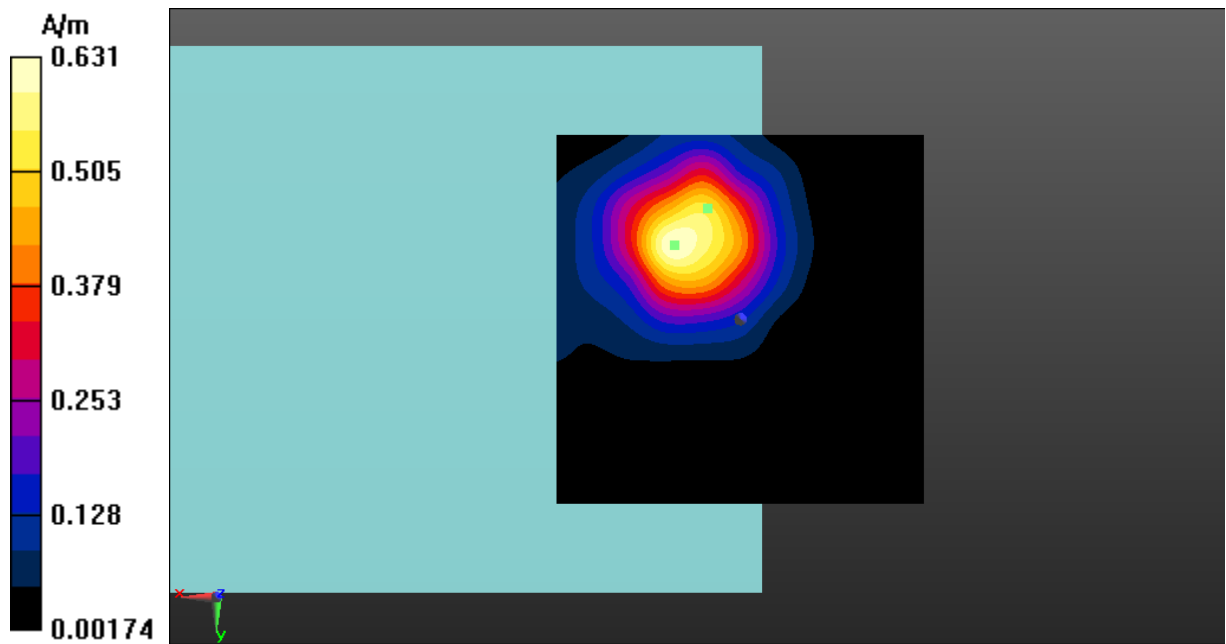

Fig A.33 T-Coil WLAN 2.4GHz-Z



T-Coil WLAN 2.4GHz Transverse

Date: 2023-1-20

Electronics: DAE4 Sn786

Medium: Air

Medium parameters used: $\sigma = 0$ S/m, $\epsilon_r = 1$; $\rho = 1$ kg/m³

Communication System: UID 0, WLAN (0) Frequency: 2437 MHz Duty Cycle: 1:1

Probe: AM1DV3 - 3086

y (transversal) 4.2mm 50 x 50/ABM Interpolated Signal(x,y,z) (101x101x1): Interpolated grid:

dx=1.000 mm, dy=1.000 mm

Signal Type: Audio File (.wav) 48k_voice_1kHz_1s.wav

Output Gain: 100

Measure Window Start: 300ms

Measure Window Length: 1000ms

BWC applied: 0.16 dB

Device Reference Point: 0, 0, -6.3 mm

Cursor:

ABM1 = -12.75 dBA/m

BWC Factor = 0.16 dB

Location: 7, -20, 3.7 mm

y (transversal) 4.2mm 50 x 50/ABM Interpolated SNR(x,y,z) (101x101x1): Interpolated grid:

dx=1.000 mm, dy=1.000 mm

Signal Type: Audio File (.wav) 48k_voice_1kHz_1s.wav

Output Gain: 100

Measure Window Start: 300ms

Measure Window Length: 1000ms

BWC applied: 0.16 dB

Device Reference Point: 0, 0, -6.3 mm

Cursor:

ABM1/ABM2 = 39.99 dB

ABM1 comp = -12.75 dBA/m

BWC Factor = 0.16 dB

Location: 7, -20, 3.7 mm

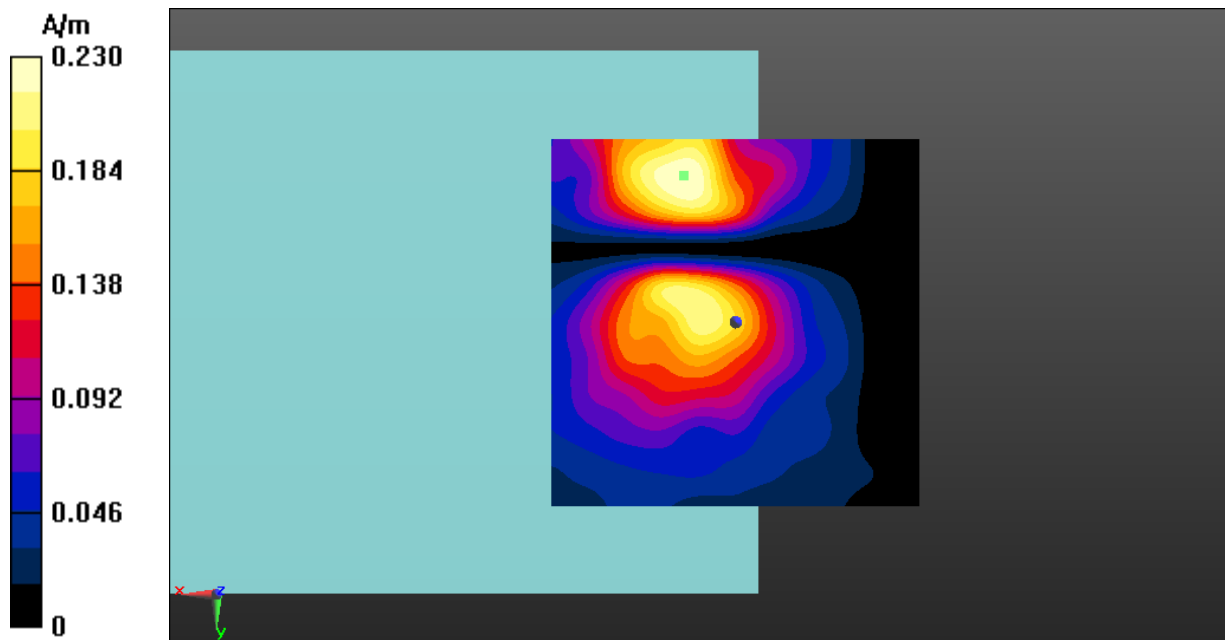

Fig A.33 T-Coil WLAN 2.4GHz-Y



T-Coil WLAN 5.2GHz Axial

Date: 2023-1-20

Electronics: DAE4 Sn786

Medium: Air

Medium parameters used: $\sigma = 0$ S/m, $\epsilon_r = 1$; $\rho = 1$ kg/m³

Communication System: UID 0, WLAN 5G (0) Frequency: 5200 MHz Duty Cycle: 1:1

Probe: AM1DV3 - 3086

z (axial) 4.2mm 50 x 50/ABM Interpolated Signal(x,y,z) (101x101x1): Interpolated grid:

dx=1.000 mm, dy=1.000 mm

Signal Type: Audio File (.wav) 48k_voice_1kHz_1s.wav

Output Gain: 100

Measure Window Start: 300ms

Measure Window Length: 1000ms

BWC applied: 0.16 dB

Device Reference Point: 0, 0, -6.3 mm

Cursor:

ABM1 = -3.78 dBA/m

BWC Factor = 0.16 dB

Location: 5.5, -10.5, 3.7 mm

z (axial) 4.2mm 50 x 50/ABM Interpolated SNR(x,y,z) (101x101x1): Interpolated grid: dx=1.000 mm, dy=1.000 mm

Signal Type: Audio File (.wav) 48k_voice_1kHz_1s.wav

Output Gain: 100

Measure Window Start: 300ms

Measure Window Length: 1000ms

BWC applied: 0.16 dB

Device Reference Point: 0, 0, -6.3 mm

Cursor:

ABM1/ABM2 = 41.85 dB

ABM1 comp = -4.00 dBA/m

BWC Factor = 0.16 dB

Location: 4.5, -11, 3.7 mm

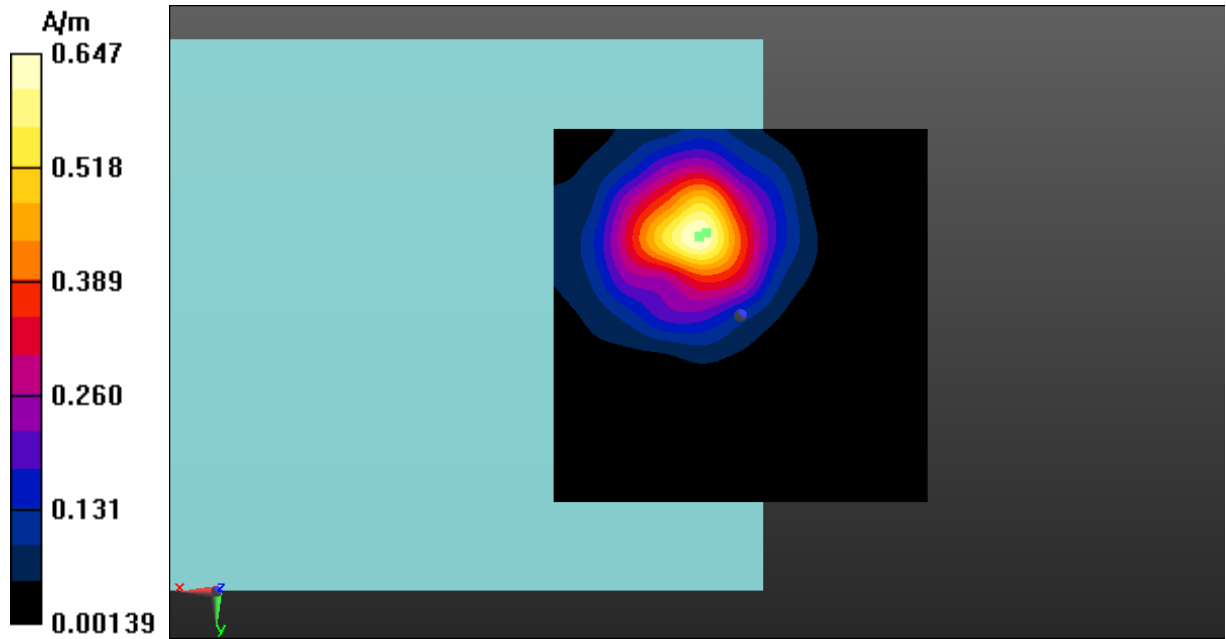

Fig A.34 T-Coil WLAN 5.2GHz-Z



T-Coil WLAN 5.2GHz Transverse

Date: 2023-1-20

Electronics: DAE4 Sn786

Medium: Air

Medium parameters used: $\sigma = 0$ S/m, $\epsilon_r = 1$; $\rho = 1$ kg/m³

Communication System: UID 0, WLAN 5G (0) Frequency: 5200 MHz Duty Cycle: 1:1

Probe: AM1DV3 - 3086

y (transversal) 4.2mm 50 x 50/ABM Interpolated Signal(x,y,z) (101x101x1): Interpolated grid:

dx=1.000 mm, dy=1.000 mm

Signal Type: Audio File (.wav) 48k_voice_1kHz_1s.wav

Output Gain: 100

Measure Window Start: 300ms

Measure Window Length: 1000ms

BWC applied: 0.16 dB

Device Reference Point: 0, 0, -6.3 mm

Cursor:

ABM1 = -12.17 dBA/m

BWC Factor = 0.16 dB

Location: 7, -19.5, 3.7 mm

y (transversal) 4.2mm 50 x 50/ABM Interpolated SNR(x,y,z) (101x101x1): Interpolated grid:

dx=1.000 mm, dy=1.000 mm

Signal Type: Audio File (.wav) 48k_voice_1kHz_1s.wav

Output Gain: 100

Measure Window Start: 300ms

Measure Window Length: 1000ms

BWC applied: 0.16 dB

Device Reference Point: 0, 0, -6.3 mm

Cursor:

ABM1/ABM2 = 36.63 dB

ABM1 comp = -12.44 dBA/m

BWC Factor = 0.16 dB

Location: 4.5, -20, 3.7 mm

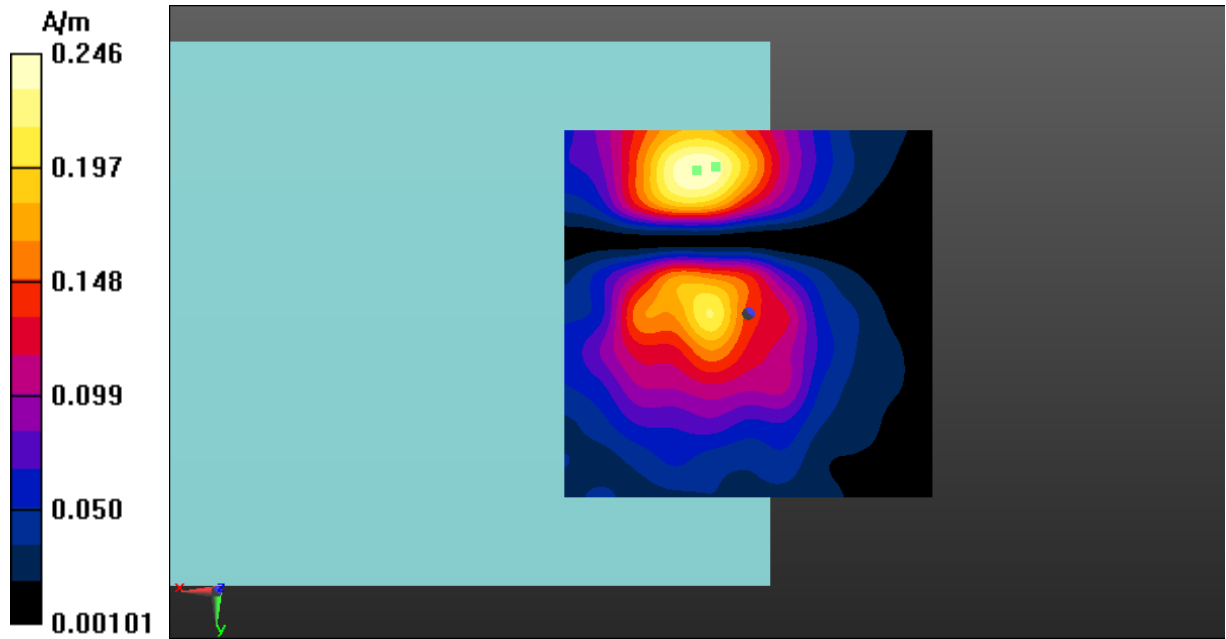

Fig A.34 T-Coil WLAN 5.2GHz-Y



T-Coil WLAN 5.3GHz Axial

Date: 2023-1-20

Electronics: DAE4 Sn786

Medium: Air

Medium parameters used: $\sigma = 0$ S/m, $\epsilon_r = 1$; $\rho = 1$ kg/m³

Communication System: UID 0, WLAN 5G (0) Frequency: 5280 MHz Duty Cycle: 1:1

Probe: AM1DV3 - 3086

z (axial) 4.2mm 50 x 50/ABM Interpolated Signal(x,y,z) (101x101x1): Interpolated grid:

dx=1.000 mm, dy=1.000 mm

Signal Type: Audio File (.wav) 48k_voice_1kHz_1s.wav

Output Gain: 100

Measure Window Start: 300ms

Measure Window Length: 1000ms

BWC applied: 0.16 dB

Device Reference Point: 0, 0, -6.3 mm

Cursor:

ABM1 = -4.00 dBA/m

BWC Factor = 0.16 dB

Location: 9.5, -11, 3.7 mm

z (axial) 4.2mm 50 x 50/ABM Interpolated SNR(x,y,z) (101x101x1): Interpolated grid: dx=1.000

mm, dy=1.000 mm

Signal Type: Audio File (.wav) 48k_voice_1kHz_1s.wav

Output Gain: 100

Measure Window Start: 300ms

Measure Window Length: 1000ms

BWC applied: 0.16 dB

Device Reference Point: 0, 0, -6.3 mm

Cursor:

ABM1/ABM2 = 43.19 dB

ABM1 comp = -6.93 dBA/m

BWC Factor = 0.16 dB

Location: 4.5, -5, 3.7 mm

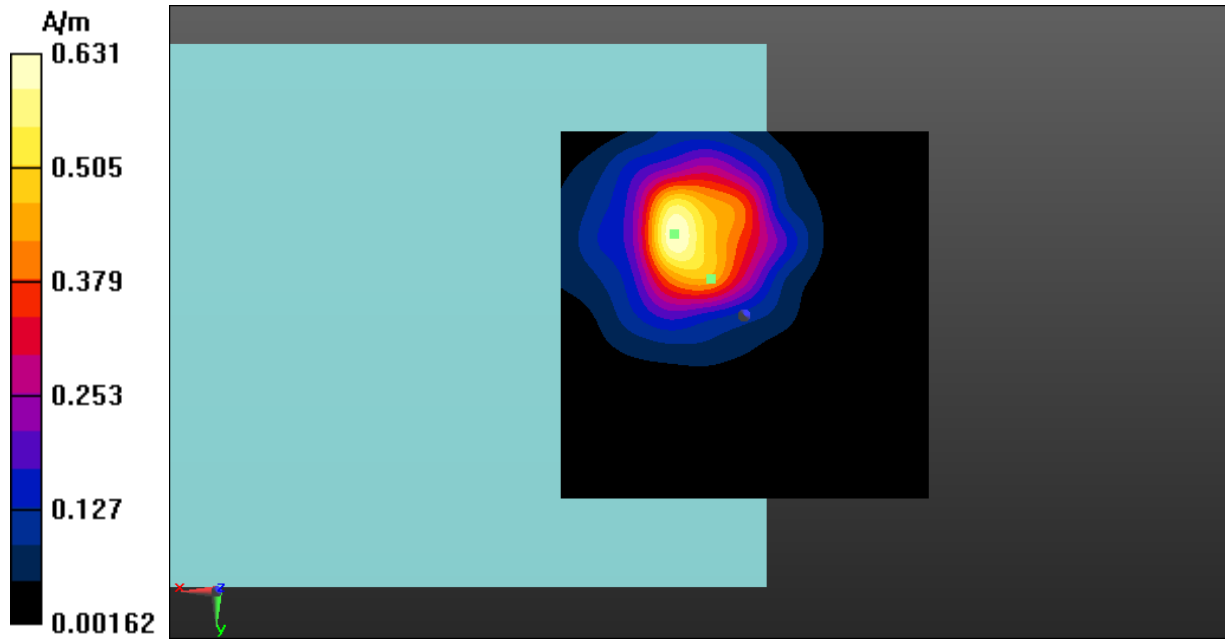

Fig A.35 T-Coil WLAN 5.3GHz-Z



T-Coil WLAN 5.3GHz Transverse

Date: 2023-1-20

Electronics: DAE4 Sn786

Medium: Air

Medium parameters used: $\sigma = 0$ S/m, $\epsilon_r = 1$; $\rho = 1$ kg/m³

Communication System: UID 0, WLAN 5G (0) Frequency: 5280 MHz Duty Cycle: 1:1

Probe: AM1DV3 - 3086

y (transversal) 4.2mm 50 x 50/ABM Interpolated Signal(x,y,z) (101x101x1): Interpolated grid:

dx=1.000 mm, dy=1.000 mm

Signal Type: Audio File (.wav) 48k_voice_1kHz_1s.wav

Output Gain: 100

Measure Window Start: 300ms

Measure Window Length: 1000ms

BWC applied: 0.16 dB

Device Reference Point: 0, 0, -6.3 mm

Cursor:

ABM1 = -12.19 dBA/m

BWC Factor = 0.16 dB

Location: 6, 0, 3.7 mm

y (transversal) 4.2mm 50 x 50/ABM Interpolated SNR(x,y,z) (101x101x1): Interpolated grid:

dx=1.000 mm, dy=1.000 mm

Signal Type: Audio File (.wav) 48k_voice_1kHz_1s.wav

Output Gain: 100

Measure Window Start: 300ms

Measure Window Length: 1000ms

BWC applied: 0.16 dB

Device Reference Point: 0, 0, -6.3 mm

Cursor:

ABM1/ABM2 = 35.45 dB

ABM1 comp = -15.09 dBA/m

BWC Factor = 0.16 dB

Location: 0, 0, 3.7 mm

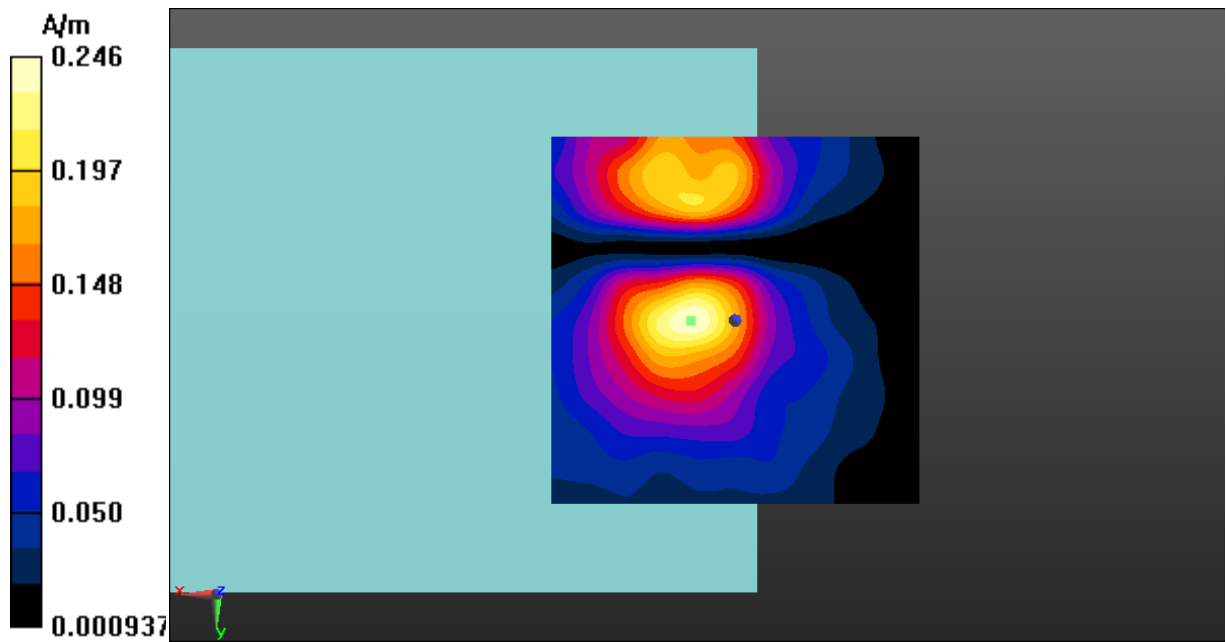

Fig A.35 T-Coil WLAN 5.3GHz-Y



T-Coil WLAN 5.5GHz Axial

Date: 2023-1-20

Electronics: DAE4 Sn786

Medium: Air

Medium parameters used: $\sigma = 0$ S/m, $\epsilon_r = 1$; $\rho = 1$ kg/m³

Communication System: UID 0, WLAN 5G (0) Frequency: 5620 MHz Duty Cycle: 1:1

Probe: AM1DV3 - 3086

z (axial) 4.2mm 50 x 50/ABM Interpolated Signal(x,y,z) (101x101x1): Interpolated grid:

dx=1.000 mm, dy=1.000 mm

Signal Type: Audio File (.wav) 48k_voice_1kHz_1s.wav

Output Gain: 100

Measure Window Start: 300ms

Measure Window Length: 1000ms

BWC applied: 0.16 dB

Device Reference Point: 0, 0, -6.3 mm

Cursor:

ABM1 = -3.33 dBA/m

BWC Factor = 0.16 dB

Location: 6, -10.5, 3.7 mm

z (axial) 4.2mm 50 x 50/ABM Interpolated SNR(x,y,z) (101x101x1): Interpolated grid: dx=1.000

mm, dy=1.000 mm

Signal Type: Audio File (.wav) 48k_voice_1kHz_1s.wav

Output Gain: 100

Measure Window Start: 300ms

Measure Window Length: 1000ms

BWC applied: 0.16 dB

Device Reference Point: 0, 0, -6.3 mm

Cursor:

ABM1/ABM2 = 47.39 dB

ABM1 comp = -3.41 dBA/m

BWC Factor = 0.16 dB

Location: 5, -10.5, 3.7 mm

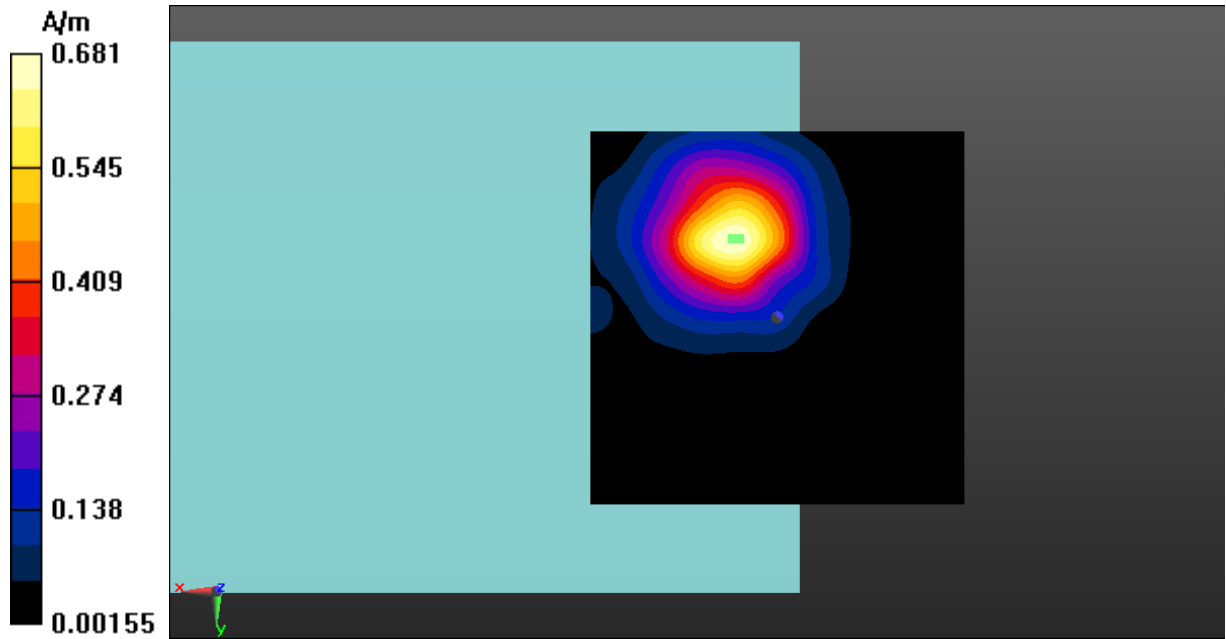

Fig A.36 T-Coil WLAN 5.5GHz-Z



T-Coil WLAN 5.5GHz Transverse

Date: 2023-1-20

Electronics: DAE4 Sn786

Medium: Air

Medium parameters used: $\sigma = 0$ S/m, $\epsilon_r = 1$; $\rho = 1$ kg/m³

Communication System: UID 0, WLAN 5G (0) Frequency: 5620 MHz Duty Cycle: 1:1

Probe: AM1DV3 - 3086

y (transversal) 4.2mm 50 x 50/ABM Interpolated Signal(x,y,z) (101x101x1): Interpolated grid:

dx=1.000 mm, dy=1.000 mm

Signal Type: Audio File (.wav) 48k_voice_1kHz_1s.wav

Output Gain: 100

Measure Window Start: 300ms

Measure Window Length: 1000ms

BWC applied: 0.16 dB

Device Reference Point: 0, 0, -6.3 mm

Cursor:

ABM1 = -12.02 dBA/m

BWC Factor = 0.16 dB

Location: 10, -20, 3.7 mm

y (transversal) 4.2mm 50 x 50/ABM Interpolated SNR(x,y,z) (101x101x1): Interpolated grid:

dx=1.000 mm, dy=1.000 mm

Signal Type: Audio File (.wav) 48k_voice_1kHz_1s.wav

Output Gain: 100

Measure Window Start: 300ms

Measure Window Length: 1000ms

BWC applied: 0.16 dB

Device Reference Point: 0, 0, -6.3 mm

Cursor:

ABM1/ABM2 = 37.21 dB

ABM1 comp = -12.49 dBA/m

BWC Factor = 0.16 dB

Location: 4.5, 1, 3.7 mm

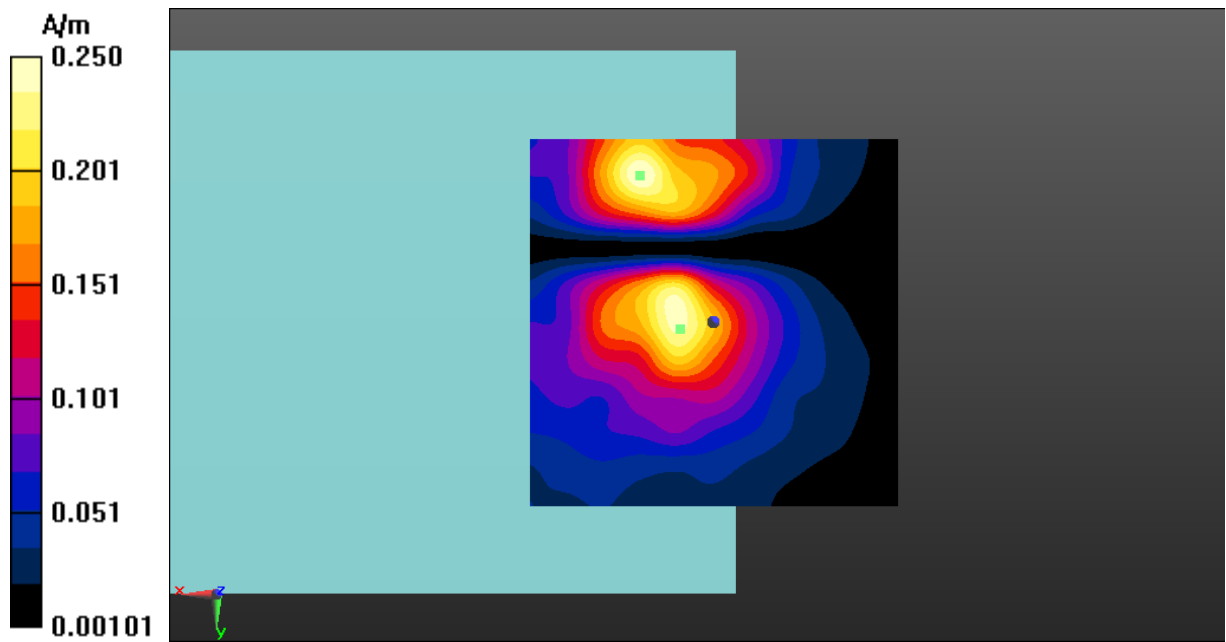

Fig A.36 T-Coil WLAN 5.5GHz-Y



T-Coil WLAN 5.8GHz Axial

Date: 2023-1-20

Electronics: DAE4 Sn786

Medium: Air

Medium parameters used: $\sigma = 0$ S/m, $\epsilon_r = 1$; $\rho = 1$ kg/m³

Communication System: UID 0, WLAN 5G (0) Frequency: 5785 MHz Duty Cycle: 1:1

Probe: AM1DV3 - 3086

z (axial) 4.2mm 50 x 50/ABM Interpolated Signal(x,y,z) (101x101x1): Interpolated grid:

dx=1.000 mm, dy=1.000 mm

Signal Type: Audio File (.wav) 48k_voice_1kHz_1s.wav

Output Gain: 100

Measure Window Start: 300ms

Measure Window Length: 1000ms

BWC applied: 0.16 dB

Device Reference Point: 0, 0, -6.3 mm

Cursor:

ABM1 = -4.60 dBA/m

BWC Factor = 0.16 dB

Location: 5.5, -10.5, 3.7 mm

z (axial) 4.2mm 50 x 50/ABM Interpolated SNR(x,y,z) (101x101x1): Interpolated grid: dx=1.000 mm, dy=1.000 mm

Signal Type: Audio File (.wav) 48k_voice_1kHz_1s.wav

Output Gain: 100

Measure Window Start: 300ms

Measure Window Length: 1000ms

BWC applied: 0.16 dB

Device Reference Point: 0, 0, -6.3 mm

Cursor:

ABM1/ABM2 = 45.77 dB

ABM1 comp = -4.70 dBA/m

BWC Factor = 0.16 dB

Location: 4.5, -10.5, 3.7 mm

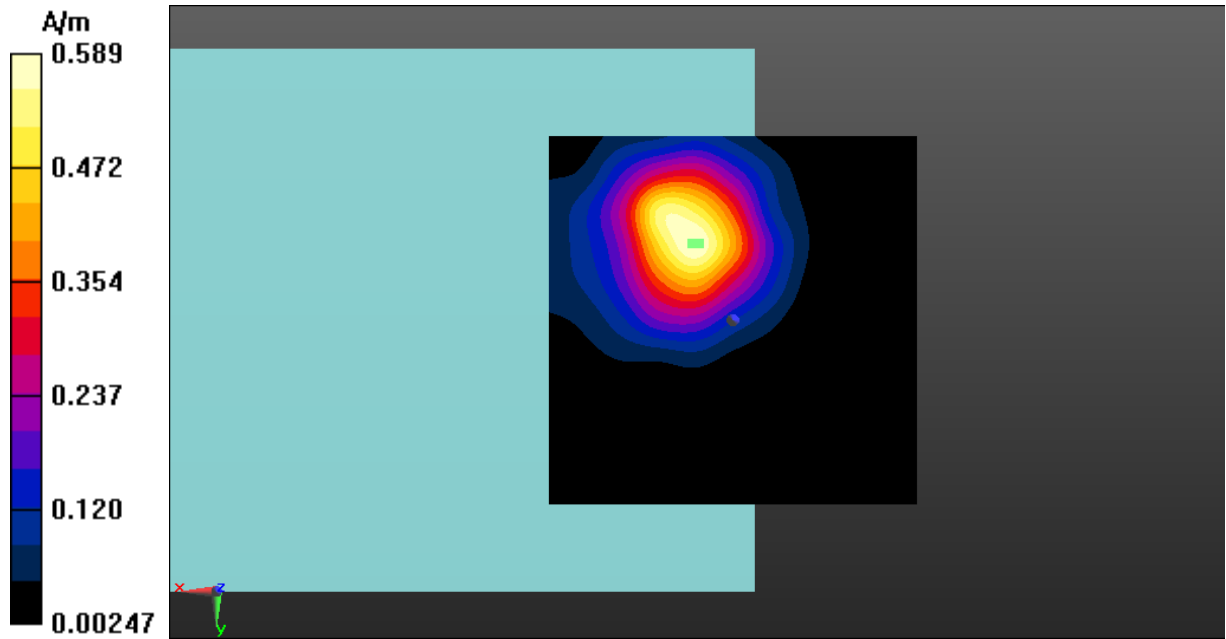

Fig A.37 T-Coil WLAN 5.8GHz-Z



T-Coil WLAN 5.8GHz Transverse

Date: 2023-1-20

Electronics: DAE4 Sn786

Medium: Air

Medium parameters used: $\sigma = 0$ S/m, $\epsilon_r = 1$; $\rho = 1$ kg/m³

Communication System: UID 0, WLAN 5G (0) Frequency: 5785 MHz Duty Cycle: 1:1

Probe: AM1DV3 - 3086

y (transversal) 4.2mm 50 x 50/ABM Interpolated Signal(x,y,z) (101x101x1): Interpolated grid:

dx=1.000 mm, dy=1.000 mm

Signal Type: Audio File (.wav) 48k_voice_1kHz_1s.wav

Output Gain: 100

Measure Window Start: 300ms

Measure Window Length: 1000ms

BWC applied: 0.16 dB

Device Reference Point: 0, 0, -6.3 mm

Cursor:

ABM1 = -12.24 dBA/m

BWC Factor = 0.16 dB

Location: 6, -0.5, 3.7 mm

y (transversal) 4.2mm 50 x 50/ABM Interpolated SNR(x,y,z) (101x101x1): Interpolated grid:

dx=1.000 mm, dy=1.000 mm

Signal Type: Audio File (.wav) 48k_voice_1kHz_1s.wav

Output Gain: 100

Measure Window Start: 300ms

Measure Window Length: 1000ms

BWC applied: 0.16 dB

Device Reference Point: 0, 0, -6.3 mm

Cursor:

ABM1/ABM2 = 35.41 dB

ABM1 comp = -15.80 dBA/m

BWC Factor = 0.16 dB

Location: 0.5, -3, 3.7 mm

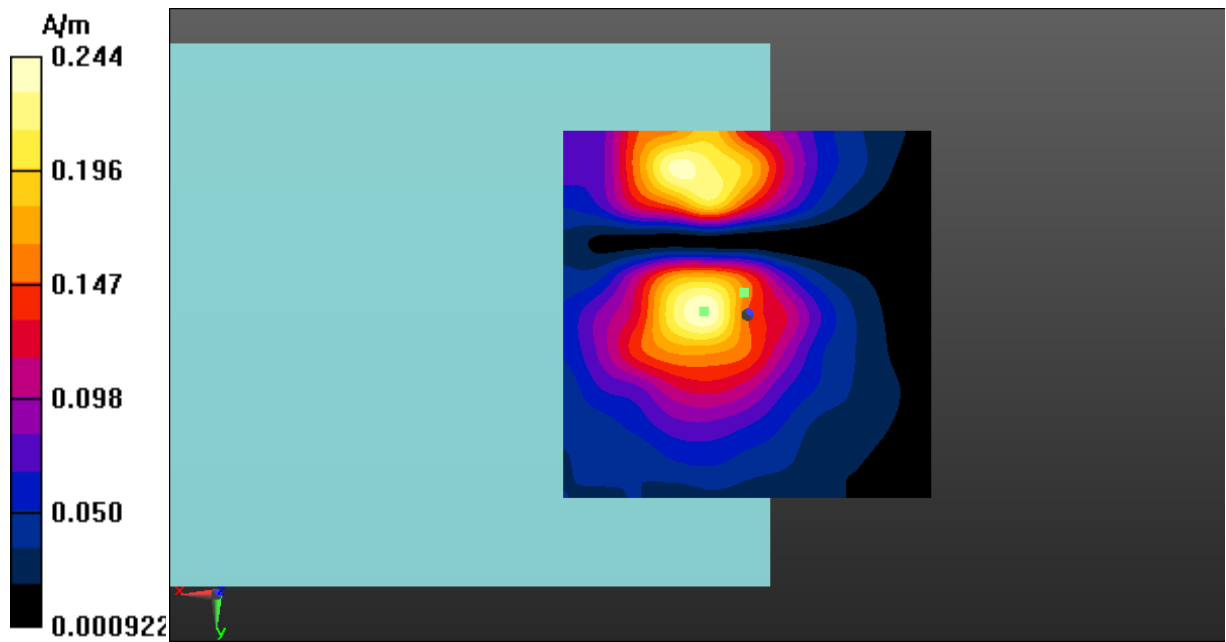

Fig A.37 T-Coil WLAN 5.8GHz-Y



T-Coil (Google Duo) GSM 850 Axial (Ant.2)

Date: 2023-2-12

Electronics: DAE4 Sn786

Medium: Air

Medium parameters used: $\sigma = 0$ S/m, $\epsilon_r = 1$; $\rho = 1$ kg/m³

Communication System: UID 0, EDGE 3TX (0) Frequency: 836.6 MHz Duty Cycle: 1:2.67

Probe: AM1DV3 - 3086

z (axial) 4.2mm 50 x 50/ABM Interpolated Signal(x,y,z) (101x101x1): Interpolated grid:

dx=1.000 mm, dy=1.000 mm

Signal Type: Audio File (.wav) 48k_voice_1kHz_1s.wav

Output Gain: 100

Measure Window Start: 300ms

Measure Window Length: 1000ms

BWC applied: 0.16 dB

Device Reference Point: 0, 0, -6.3 mm

Cursor:

ABM1 = 11.49 dBA/m

BWC Factor = 0.16 dB

Location: 6.5, -10, 3.7 mm

z (axial) 4.2mm 50 x 50/ABM Interpolated SNR(x,y,z) (101x101x1): Interpolated grid: dx=1.000 mm, dy=1.000 mm

Signal Type: Audio File (.wav) 48k_voice_1kHz_1s.wav

Output Gain: 100

Measure Window Start: 300ms

Measure Window Length: 1000ms

BWC applied: 0.16 dB

Device Reference Point: 0, 0, -6.3 mm

Cursor:

ABM1/ABM2 = 55.98 dB

ABM1 comp = 11.37 dBA/m

BWC Factor = 0.16 dB

Location: 5.5, -10.5, 3.7 mm

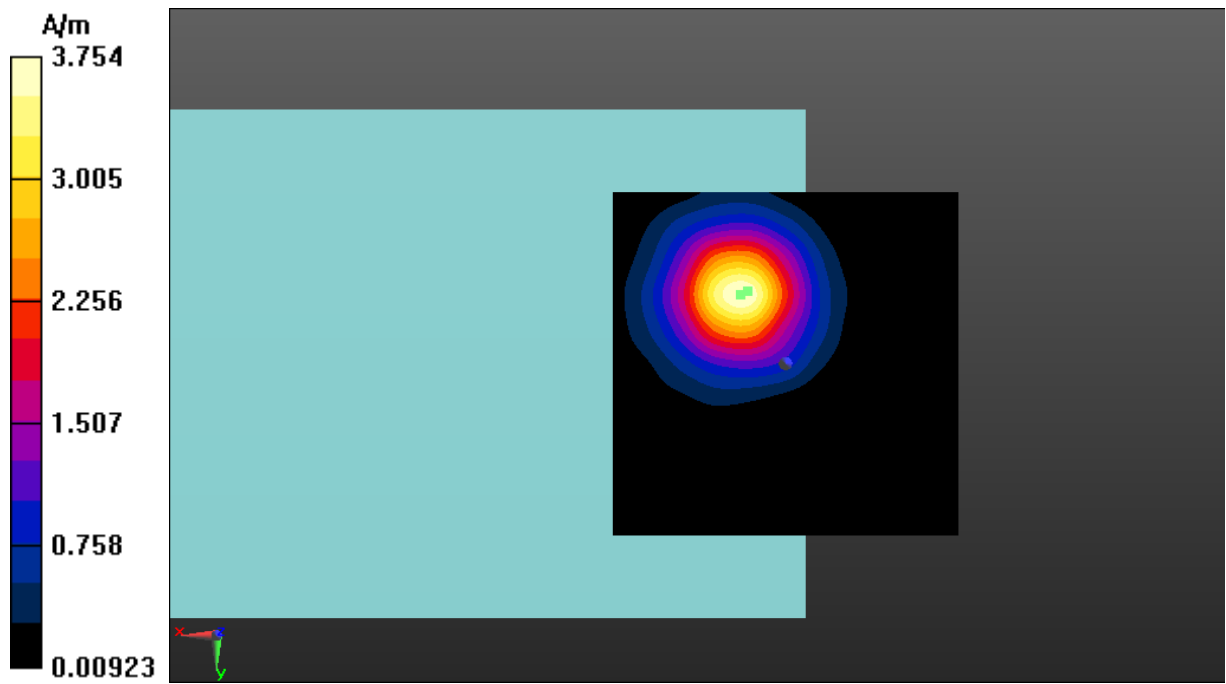

Fig A.38 T-Coil GSM 850-Z



T-Coil (Google Duo) GSM 850 Transverse (Ant.2)

Date: 2023-2-12

Electronics: DAE4 Sn786

Medium: Air

Medium parameters used: $\sigma = 0$ S/m, $\epsilon_r = 1$; $\rho = 1$ kg/m³

Communication System: UID 0, EDGE 3TX (0) Frequency: 836.6 MHz Duty Cycle: 1:2.67

Probe: AM1DV3 - 3086

y (transversal) 4.2mm 50 x 50/ABM Interpolated Signal(x,y,z) (101x101x1): Interpolated grid:

dx=1.000 mm, dy=1.000 mm

Signal Type: Audio File (.wav) 48k_voice_1kHz_1s.wav

Output Gain: 100

Measure Window Start: 300ms

Measure Window Length: 1000ms

BWC applied: 0.16 dB

Device Reference Point: 0, 0, -6.3 mm

Cursor:

ABM1 = 3.14 dBA/m

BWC Factor = 0.16 dB

Location: 2, -20.5, 3.7 mm

y (transversal) 4.2mm 50 x 50/ABM Interpolated SNR(x,y,z) (101x101x1): Interpolated grid:

dx=1.000 mm, dy=1.000 mm

Signal Type: Audio File (.wav) 48k_voice_1kHz_1s.wav

Output Gain: 100

Measure Window Start: 300ms

Measure Window Length: 1000ms

BWC applied: 0.16 dB

Device Reference Point: 0, 0, -6.3 mm

Cursor:

ABM1/ABM2 = 49.82 dB

ABM1 comp = 2.76 dBA/m

BWC Factor = 0.16 dB

Location: 0, -20.5, 3.7 mm

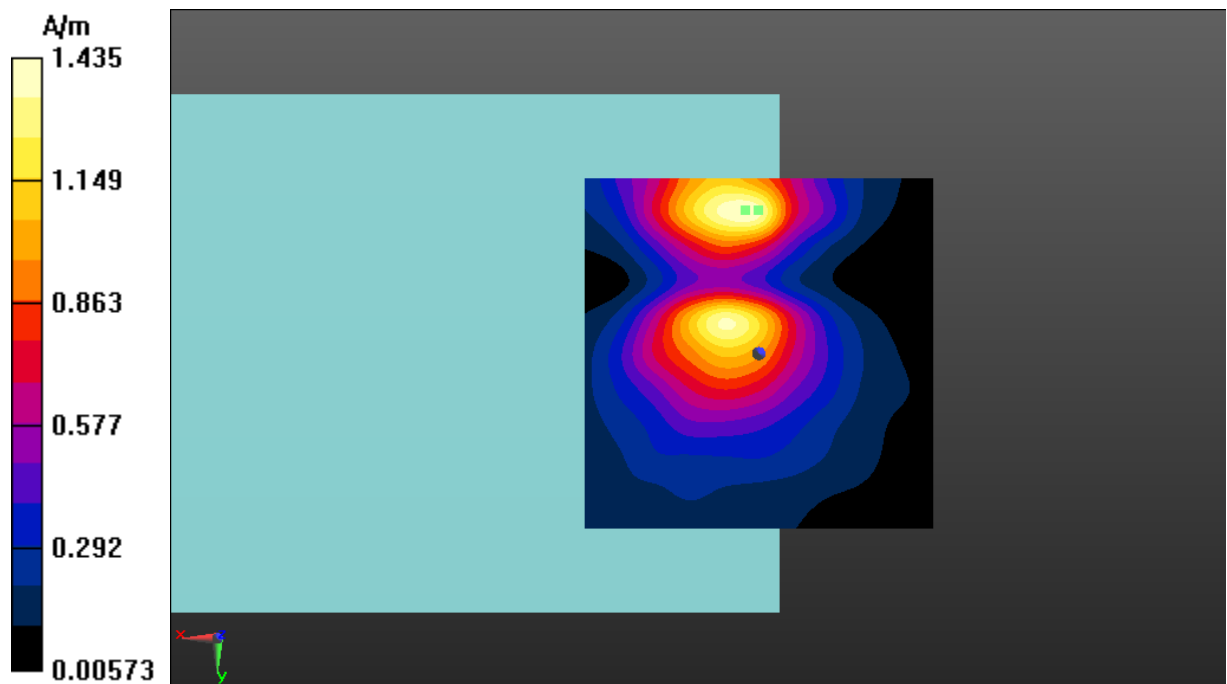

Fig A.38 T-Coil GSM 850-Y



T-Coil (Google Duo) WCDMA Band 5 Axial (Ant.1)

Date: 2023-2-12

Electronics: DAE4 Sn786

Medium: Air

Medium parameters used: $\sigma = 0$ S/m, $\epsilon_r = 1$; $\rho = 1$ kg/m³

Communication System: UID 0, WCDMA (0) Frequency: 836.4 MHz Duty Cycle: 1:1

Probe: AM1DV3 - 3086

z (axial) 4.2mm 50 x 50/ABM Interpolated Signal(x,y,z) (101x101x1): Interpolated grid:

dx=1.000 mm, dy=1.000 mm

Signal Type: Audio File (.wav) 48k_voice_1kHz_1s.wav

Output Gain: 100

Measure Window Start: 300ms

Measure Window Length: 1000ms

BWC applied: 0.16 dB

Device Reference Point: 0, 0, -6.3 mm

Cursor:

ABM1 = 3.04 dBA/m

BWC Factor = 0.16 dB

Location: 6, -10, 3.7 mm

z (axial) 4.2mm 50 x 50/ABM Interpolated SNR(x,y,z) (101x101x1): Interpolated grid: dx=1.000 mm, dy=1.000 mm

Signal Type: Audio File (.wav) 48k_voice_1kHz_1s.wav

Output Gain: 100

Measure Window Start: 300ms

Measure Window Length: 1000ms

BWC applied: 0.16 dB

Device Reference Point: 0, 0, -6.3 mm

Cursor:

ABM1/ABM2 = 46.95 dB

ABM1 comp = 2.90 dBA/m

BWC Factor = 0.16 dB

Location: 5, -10.5, 3.7 mm

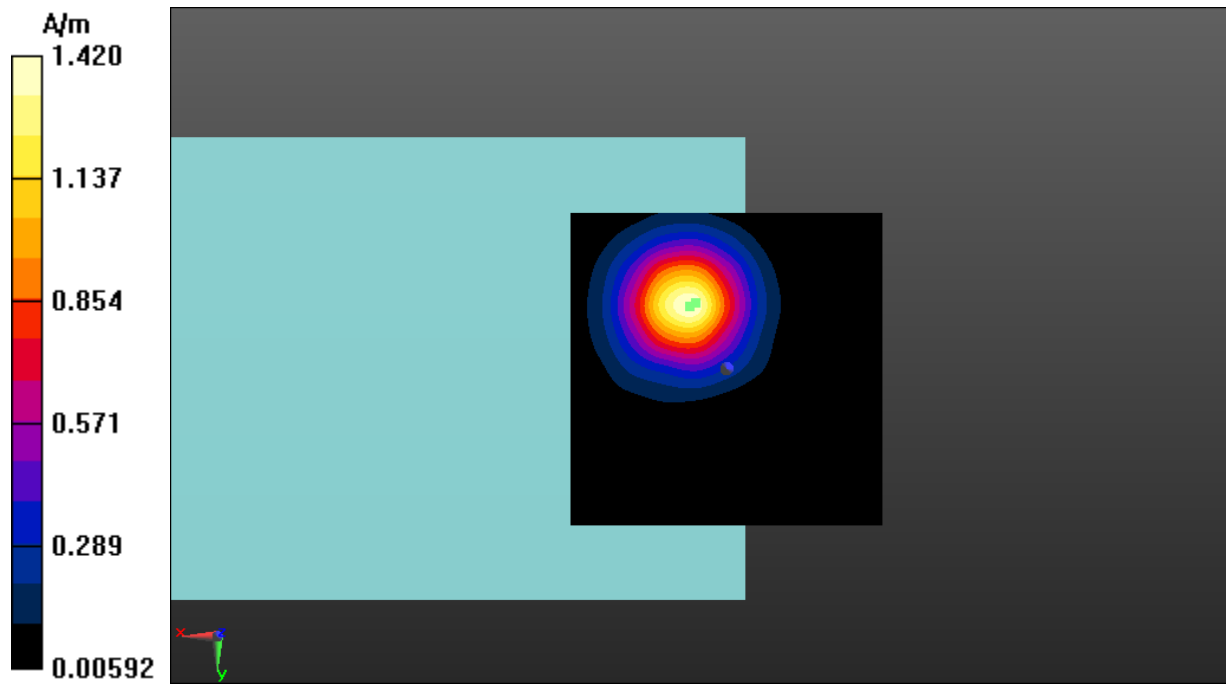

Fig A.39 T-Coil WCDMA Band 5-Z



T-Coil (Google Duo) WCDMA Band 5 Transverse (Ant.1)

Date: 2023-2-12

Electronics: DAE4 Sn786

Medium: Air

Medium parameters used: $\sigma = 0$ S/m, $\epsilon_r = 1$; $\rho = 1$ kg/m³

Communication System: UID 0, WCDMA (0) Frequency: 836.4 MHz Duty Cycle: 1:1

Probe: AM1DV3 - 3086

y (transversal) 4.2mm 50 x 50/ABM Interpolated Signal(x,y,z) (101x101x1): Interpolated grid:

dx=1.000 mm, dy=1.000 mm

Signal Type: Audio File (.wav) 48k_voice_1kHz_1s.wav

Output Gain: 100

Measure Window Start: 300ms

Measure Window Length: 1000ms

BWC applied: 0.16 dB

Device Reference Point: 0, 0, -6.3 mm

Cursor:

ABM1 = -5.72 dBA/m

BWC Factor = 0.16 dB

Location: 5, -20, 3.7 mm

y (transversal) 4.2mm 50 x 50/ABM Interpolated SNR(x,y,z) (101x101x1): Interpolated grid:

dx=1.000 mm, dy=1.000 mm

Signal Type: Audio File (.wav) 48k_voice_1kHz_1s.wav

Output Gain: 100

Measure Window Start: 300ms

Measure Window Length: 1000ms

BWC applied: 0.16 dB

Device Reference Point: 0, 0, -6.3 mm

Cursor:

ABM1/ABM2 = 40.02 dB

ABM1 comp = -7.74 dBA/m

BWC Factor = 0.16 dB

Location: 0, -20.5, 3.7 mm

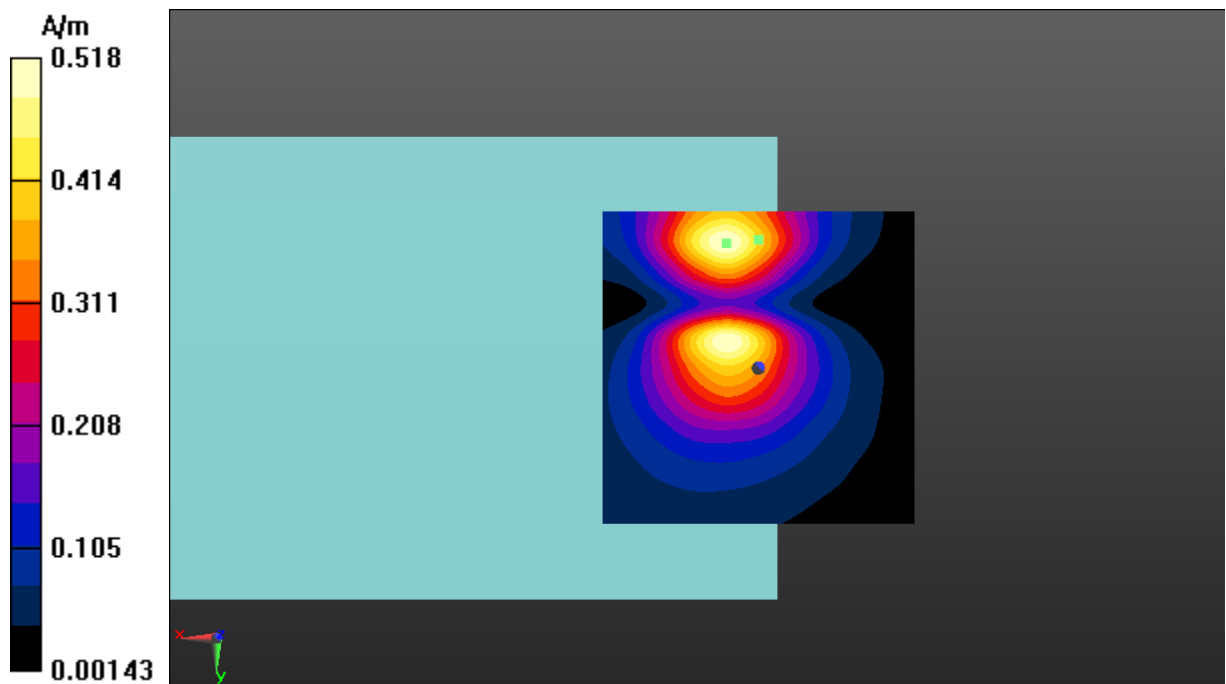

Fig A.39 T-Coil WCDMA Band 5-Y



T-Coil (Google Duo) LTE-Band 41 PC2 Axial (Ant.2)

Date: 2023-2-12

Electronics: DAE4 Sn786

Medium: Air

Medium parameters used: $\sigma = 0$ S/m, $\epsilon_r = 1$; $\rho = 1$ kg/m³

Communication System: UID 0, LTE TDD HPUE (0) Frequency: 2593 MHz Duty Cycle: 1:2.31

Probe: AM1DV3 - 3086

z (axial) 4.2mm 50 x 50/ABM Interpolated Signal(x,y,z) (101x101x1): Interpolated grid:

dx=1.000 mm, dy=1.000 mm

Signal Type: Audio File (.wav) 48k_voice_1kHz_1s.wav

Output Gain: 100

Measure Window Start: 300ms

Measure Window Length: 1000ms

BWC applied: 0.15 dB

Device Reference Point: 0, 0, -6.3 mm

Cursor:

ABM1 = 3.35 dBA/m

BWC Factor = 0.15 dB

Location: 5.5, -11, 3.7 mm

z (axial) 4.2mm 50 x 50/ABM Interpolated SNR(x,y,z) (101x101x1): Interpolated grid: dx=1.000

mm, dy=1.000 mm

Signal Type: Audio File (.wav) 48k_voice_1kHz_1s.wav

Output Gain: 100

Measure Window Start: 300ms

Measure Window Length: 1000ms

BWC applied: 0.15 dB

Device Reference Point: 0, 0, -6.3 mm

Cursor:

ABM1/ABM2 = 42.15 dB

ABM1 comp = 3.03 dBA/m

BWC Factor = 0.15 dB

Location: 5, -9.5, 3.7 mm

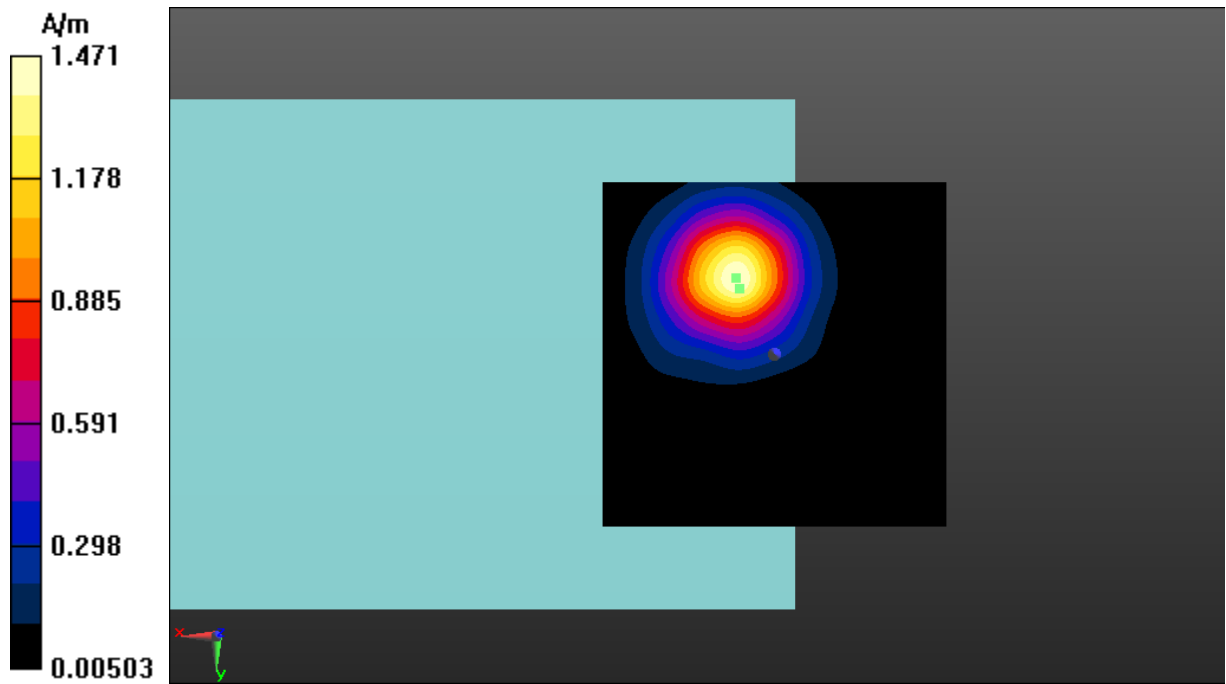

Fig A.40 T-Coil LTE-Band 41 PC2-Z



T-Coil (Google Duo) LTE-Band 41 PC2 Axial (Ant.2)

Date: 2023-2-12

Electronics: DAE4 Sn786

Medium: Air

Medium parameters used: $\sigma = 0$ S/m, $\epsilon_r = 1$; $\rho = 1$ kg/m³

Communication System: UID 0, LTE TDD HPUE (0) Frequency: 2593 MHz Duty Cycle: 1:2.31

Probe: AM1DV3 - 3086

y (transversal) 4.2mm 50 x 50/ABM Interpolated Signal(x,y,z) (101x101x1): Interpolated grid:

dx=1.000 mm, dy=1.000 mm

Signal Type: Audio File (.wav) 48k_voice_1kHz_1s.wav

Output Gain: 100

Measure Window Start: 300ms

Measure Window Length: 1000ms

BWC applied: 0.15 dB

Device Reference Point: 0, 0, -6.3 mm

Cursor:

ABM1 = -5.47 dBA/m

BWC Factor = 0.15 dB

Location: 5, -4, 3.7 mm

y (transversal) 4.2mm 50 x 50/ABM Interpolated SNR(x,y,z) (101x101x1): Interpolated grid:

dx=1.000 mm, dy=1.000 mm

Signal Type: Audio File (.wav) 48k_voice_1kHz_1s.wav

Output Gain: 100

Measure Window Start: 300ms

Measure Window Length: 1000ms

BWC applied: 0.15 dB

Device Reference Point: 0, 0, -6.3 mm

Cursor:

ABM1/ABM2 = 33.40 dB

ABM1 comp = -8.54 dBA/m

BWC Factor = 0.15 dB

Location: -1.5, -19.5, 3.7 mm

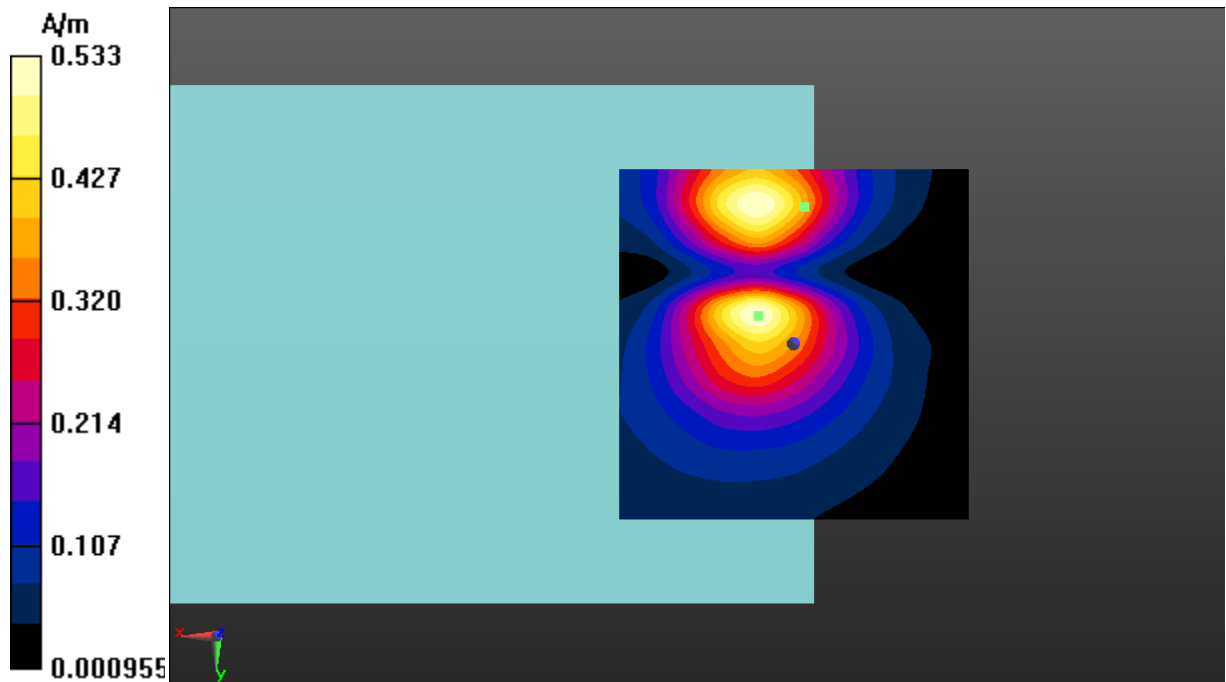

Fig A.40 T-Coil LTE-Band 41 PC2-Y



T-Coil (Google Duo) LTE-Band 71 Axial (Ant.2)

Date: 2023-2-12

Electronics: DAE4 Sn786

Medium: Air

Medium parameters used: $\sigma = 0$ S/m, $\epsilon_r = 1$; $\rho = 1$ kg/m³

Communication System: UID 0, LTE_FDD (0) Frequency: 680.5 MHz Duty Cycle: 1:1

Probe: AM1DV3 - 3086

z (axial) 4.2mm 50 x 50/ABM Interpolated Signal(x,y,z) (101x101x1): Interpolated grid:

dx=1.000 mm, dy=1.000 mm

Signal Type: Audio File (.wav) 48k_voice_1kHz_1s.wav

Output Gain: 100

Measure Window Start: 300ms

Measure Window Length: 1000ms

BWC applied: 0.16 dB

Device Reference Point: 0, 0, -6.3 mm

Cursor:

ABM1 = 5.74 dBA/m

BWC Factor = 0.16 dB

Location: 7.5, -10, 3.7 mm

z (axial) 4.2mm 50 x 50/ABM Interpolated SNR(x,y,z) (101x101x1): Interpolated grid: dx=1.000 mm, dy=1.000 mm

Signal Type: Audio File (.wav) 48k_voice_1kHz_1s.wav

Output Gain: 100

Measure Window Start: 300ms

Measure Window Length: 1000ms

BWC applied: 0.16 dB

Device Reference Point: 0, 0, -6.3 mm

Cursor:

ABM1/ABM2 = 50.89 dB

ABM1 comp = 5.47 dBA/m

BWC Factor = 0.16 dB

Location: 6, -11, 3.7 mm

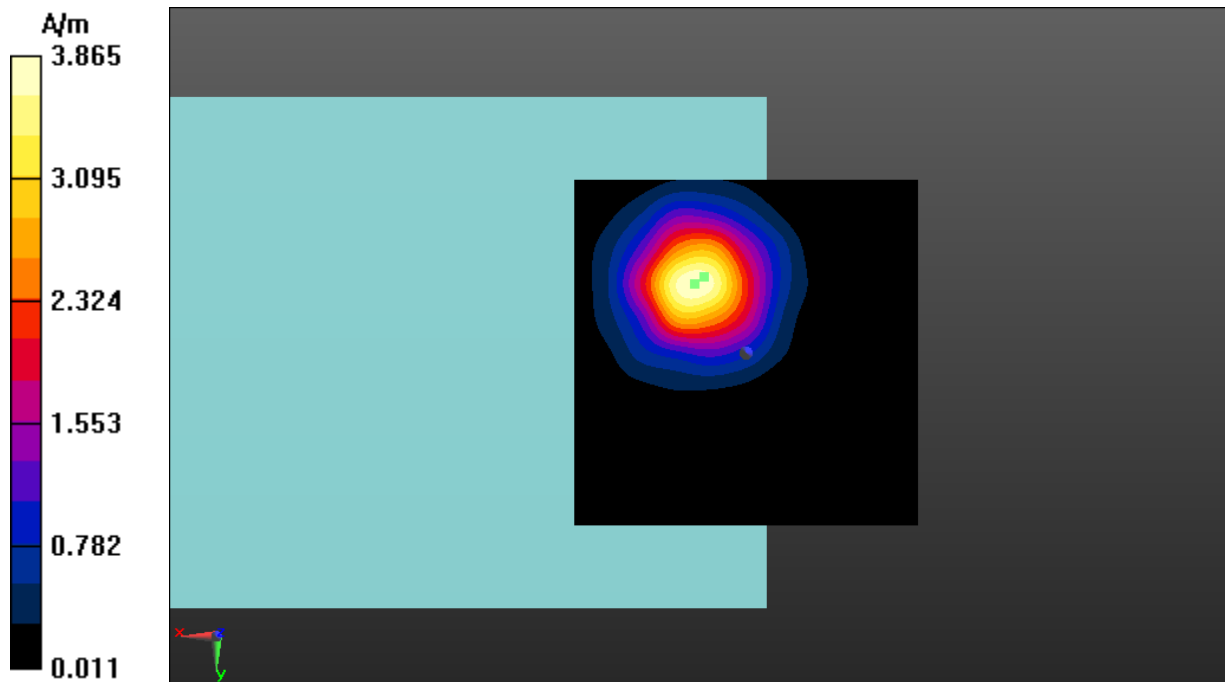

Fig A.41 T-Coil LTE-Band 71-Z



T-Coil (Google Duo) LTE-Band 71 Transverse (Ant.2)

Date: 2023-2-12

Electronics: DAE4 Sn786

Medium: Air

Medium parameters used: $\sigma = 0$ S/m, $\epsilon_r = 1$; $\rho = 1$ kg/m³

Communication System: UID 0, LTE_FDD (0) Frequency: 680.5 MHz Duty Cycle: 1:1

Probe: AM1DV3 - 3086

y (transversal) 4.2mm 50 x 50/ABM Interpolated Signal(x,y,z) (101x101x1): Interpolated grid:

dx=1.000 mm, dy=1.000 mm

Signal Type: Audio File (.wav) 48k_voice_1kHz_1s.wav

Output Gain: 100

Measure Window Start: 300ms

Measure Window Length: 1000ms

BWC applied: 0.16 dB

Device Reference Point: 0, 0, -6.3 mm

Cursor:

ABM1 = -4.11 dBA/m

BWC Factor = 0.16 dB

Location: 5, -4.5, 3.7 mm

y (transversal) 4.2mm 50 x 50/ABM Interpolated SNR(x,y,z) (101x101x1): Interpolated grid:

dx=1.000 mm, dy=1.000 mm

Signal Type: Audio File (.wav) 48k_voice_1kHz_1s.wav

Output Gain: 100

Measure Window Start: 300ms

Measure Window Length: 1000ms

BWC applied: 0.16 dB

Device Reference Point: 0, 0, -6.3 mm

Cursor:

ABM1/ABM2 = 43.52 dB

ABM1 comp = -4.84 dBA/m

BWC Factor = 0.16 dB

Location: 2, -20.5, 3.7 mm

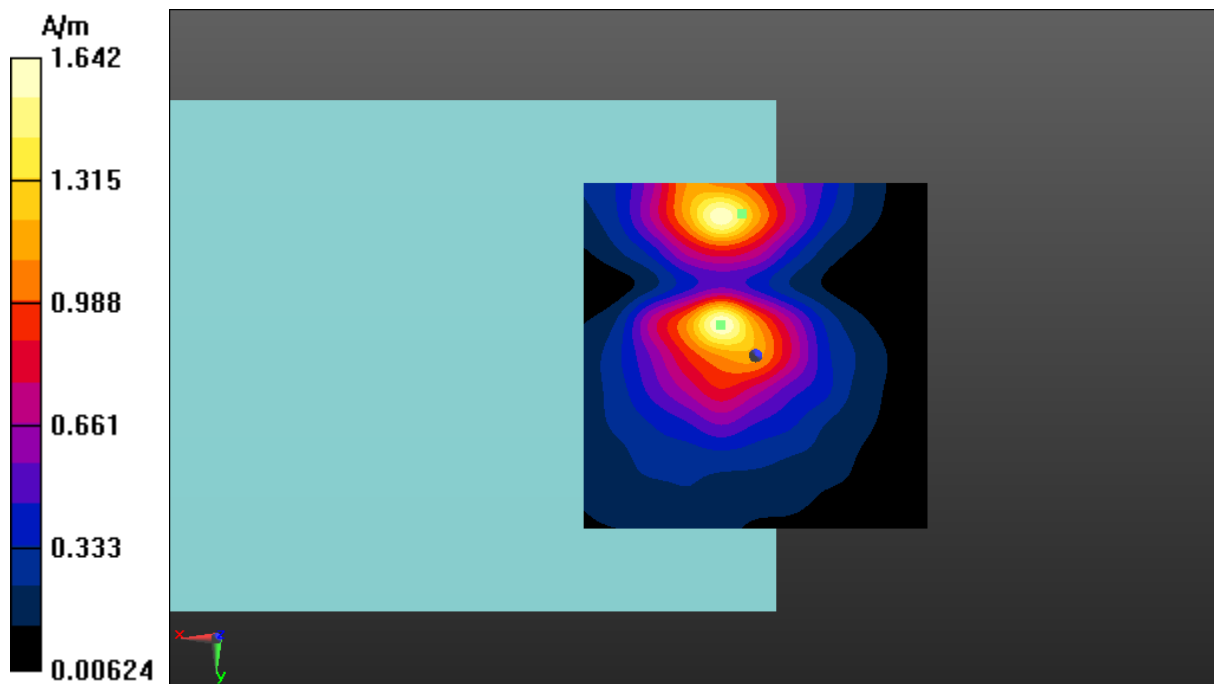

Fig A.41 T-Coil LTE-Band 41-Y



T-Coil (Google Duo) WLAN 2.4GHz Axial

Date: 2023-2-12

Electronics: DAE4 Sn786

Medium: Air

Medium parameters used: $\sigma = 0$ S/m, $\epsilon_r = 1$; $\rho = 1$ kg/m³

Communication System: UID 0, WLAN (0) Frequency: 2437 MHz Duty Cycle: 1:1

Probe: AM1DV3 - 3086

z (axial) 4.2mm 50 x 50/ABM Interpolated Signal(x,y,z) (101x101x1): Interpolated grid:

dx=1.000 mm, dy=1.000 mm

Signal Type: Audio File (.wav) 48k_voice_1kHz_1s.wav

Output Gain: 100

Measure Window Start: 300ms

Measure Window Length: 1000ms

BWC applied: 0.15 dB

Device Reference Point: 0, 0, -6.3 mm

Cursor:

ABM1 = -0.04 dBA/m

BWC Factor = 0.15 dB

Location: 7, -10.5, 3.7 mm

z (axial) 4.2mm 50 x 50/ABM Interpolated SNR(x,y,z) (101x101x1): Interpolated grid: dx=1.000

mm, dy=1.000 mm

Signal Type: Audio File (.wav) 48k_voice_1kHz_1s.wav

Output Gain: 100

Measure Window Start: 300ms

Measure Window Length: 1000ms

BWC applied: 0.15 dB

Device Reference Point: 0, 0, -6.3 mm

Cursor:

ABM1/ABM2 = 45.39 dB

ABM1 comp = -0.35 dBA/m

BWC Factor = 0.15 dB

Location: 5, -11, 3.7 mm

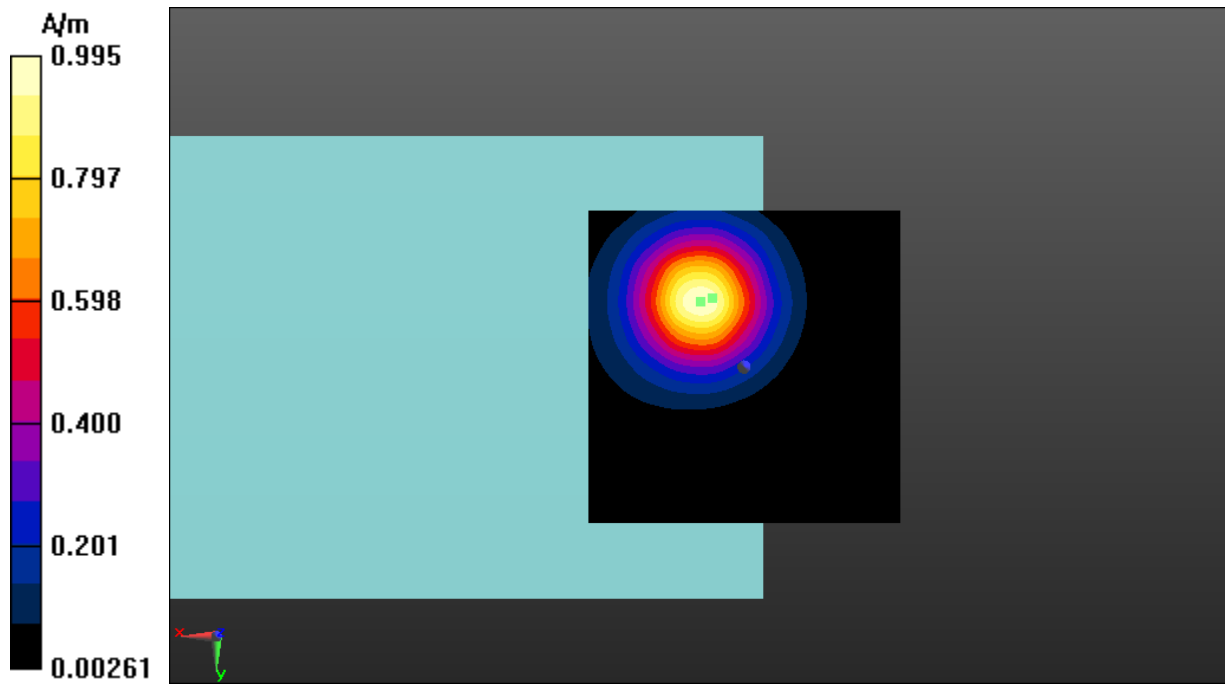

Fig A.42 T-Coil WLAN 2.4GHz-Z



T-Coil (Google Duo) WLAN 2.4GHz Transverse

Date: 2023-2-12

Electronics: DAE4 Sn786

Medium: Air

Medium parameters used: $\sigma = 0$ S/m, $\epsilon_r = 1$; $\rho = 1$ kg/m³

Communication System: UID 0, WLAN (0) Frequency: 2437 MHz Duty Cycle: 1:1

Probe: AM1DV3 - 3086

y (transversal) 4.2mm 50 x 50/ABM Interpolated Signal(x,y,z) (101x101x1): Interpolated grid:

dx=1.000 mm, dy=1.000 mm

Signal Type: Audio File (.wav) 48k_voice_1kHz_1s.wav

Output Gain: 100

Measure Window Start: 300ms

Measure Window Length: 1000ms

BWC applied: 0.15 dB

Device Reference Point: 0, 0, -6.3 mm

Cursor:

ABM1 = -9.44 dBA/m

BWC Factor = 0.15 dB

Location: 7, 0, 3.7 mm

y (transversal) 4.2mm 50 x 50/ABM Interpolated SNR(x,y,z) (101x101x1): Interpolated grid:

dx=1.000 mm, dy=1.000 mm

Signal Type: Audio File (.wav) 48k_voice_1kHz_1s.wav

Output Gain: 100

Measure Window Start: 300ms

Measure Window Length: 1000ms

BWC applied: 0.15 dB

Device Reference Point: 0, 0, -6.3 mm

Cursor:

ABM1/ABM2 = 34.93 dB

ABM1 comp = -11.42 dBA/m

BWC Factor = 0.15 dB

Location: 0.5, -20, 3.7 mm

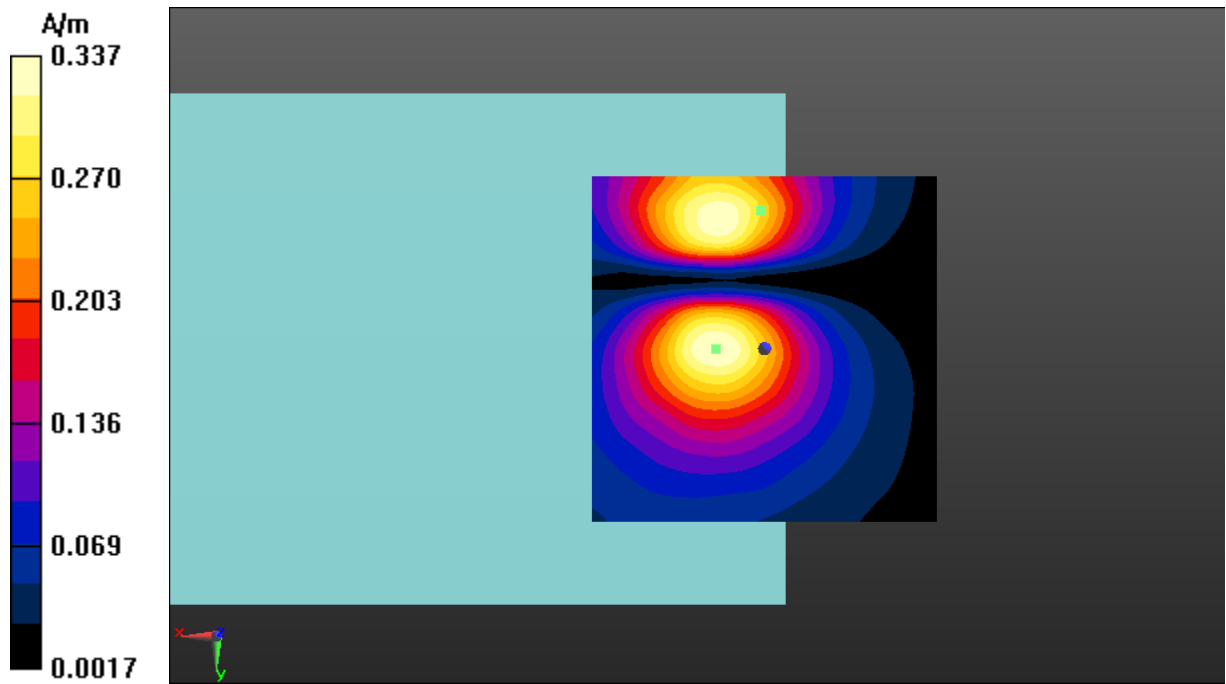

Fig A.42 T-Coil WLAN 2.4GHz-Y



T-Coil (Google Duo) WLAN 5.8GHz Axial

Date: 2023-2-12

Electronics: DAE4 Sn786

Medium: Air

Medium parameters used: $\sigma = 0$ S/m, $\epsilon_r = 1$; $\rho = 1$ kg/m³

Communication System: UID 0, WLAN 5G (0) Frequency: 5785 MHz Duty Cycle: 1:1

Probe: AM1DV3 - 3086

z (axial) 4.2mm 50 x 50/ABM Interpolated Signal(x,y,z) (101x101x1): Interpolated grid:

dx=1.000 mm, dy=1.000 mm

Signal Type: Audio File (.wav) 48k_voice_1kHz_1s.wav

Output Gain: 100

Measure Window Start: 300ms

Measure Window Length: 1000ms

BWC applied: 0.16 dB

Device Reference Point: 0, 0, -6.3 mm

Cursor:

ABM1 = -0.12 dBA/m

BWC Factor = 0.16 dB

Location: 7, -10.5, 3.7 mm

z (axial) 4.2mm 50 x 50/ABM Interpolated SNR(x,y,z) (101x101x1): Interpolated grid: dx=1.000 mm, dy=1.000 mm

Signal Type: Audio File (.wav) 48k_voice_1kHz_1s.wav

Output Gain: 100

Measure Window Start: 300ms

Measure Window Length: 1000ms

BWC applied: 0.16 dB

Device Reference Point: 0, 0, -6.3 mm

Cursor:

ABM1/ABM2 = 43.70 dB

ABM1 comp = -0.29 dBA/m

BWC Factor = 0.16 dB

Location: 5.5, -10.5, 3.7 mm

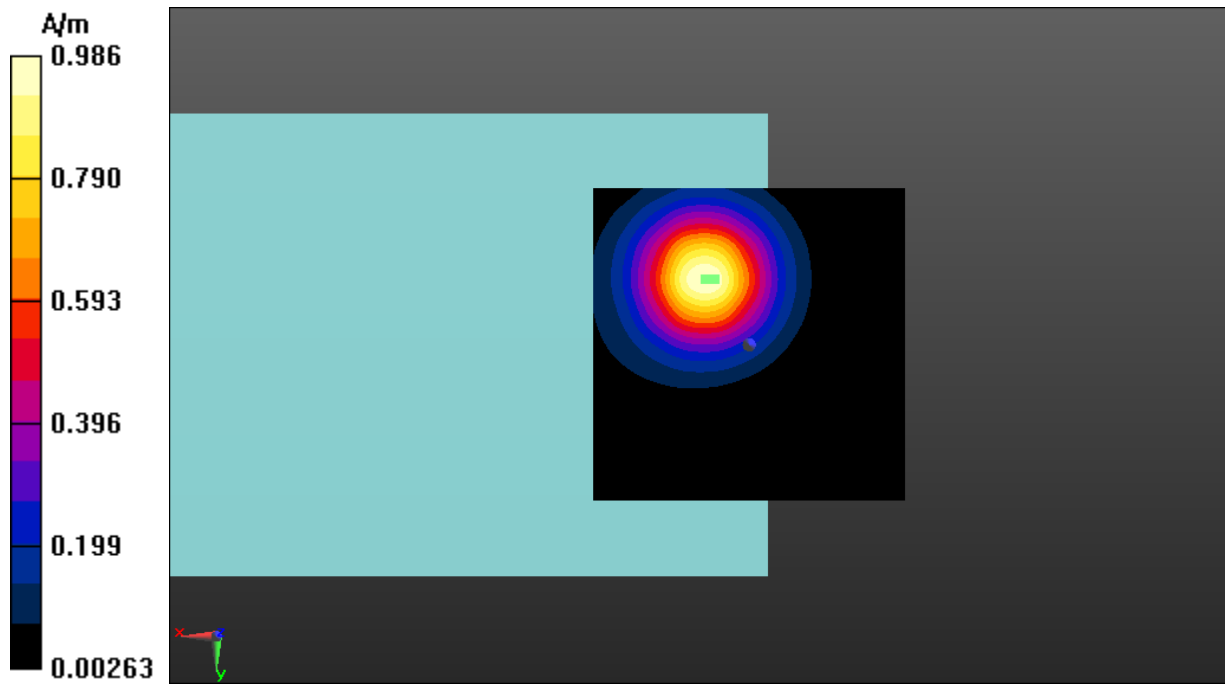

Fig A.43 T-Coil WLAN 5.8GHz-Z



T-Coil (Google Duo) WLAN 5.8GHz Transverse

Date: 2023-2-12

Electronics: DAE4 Sn786

Medium: Air

Medium parameters used: $\sigma = 0$ S/m, $\epsilon_r = 1$; $\rho = 1$ kg/m³

Communication System: UID 0, WLAN 5G (0) Frequency: 5785 MHz Duty Cycle: 1:1

Probe: AM1DV3 - 3086

y (transversal) 4.2mm 50 x 50/ABM Interpolated Signal(x,y,z) (101x101x1): Interpolated grid:

dx=1.000 mm, dy=1.000 mm

Signal Type: Audio File (.wav) 48k_voice_1kHz_1s.wav

Output Gain: 100

Measure Window Start: 300ms

Measure Window Length: 1000ms

BWC applied: 0.16 dB

Device Reference Point: 0, 0, -6.3 mm

Cursor:

ABM1 = -9.38 dBA/m

BWC Factor = 0.16 dB

Location: 6.5, -19.5, 3.7 mm

y (transversal) 4.2mm 50 x 50/ABM Interpolated SNR(x,y,z) (101x101x1): Interpolated grid:

dx=1.000 mm, dy=1.000 mm

Signal Type: Audio File (.wav) 48k_voice_1kHz_1s.wav

Output Gain: 100

Measure Window Start: 300ms

Measure Window Length: 1000ms

BWC applied: 0.16 dB

Device Reference Point: 0, 0, -6.3 mm

Cursor:

ABM1/ABM2 = 33.86 dB

ABM1 comp = -11.54 dBA/m

BWC Factor = 0.16 dB

Location: 0.5, 0.5, 3.7 mm

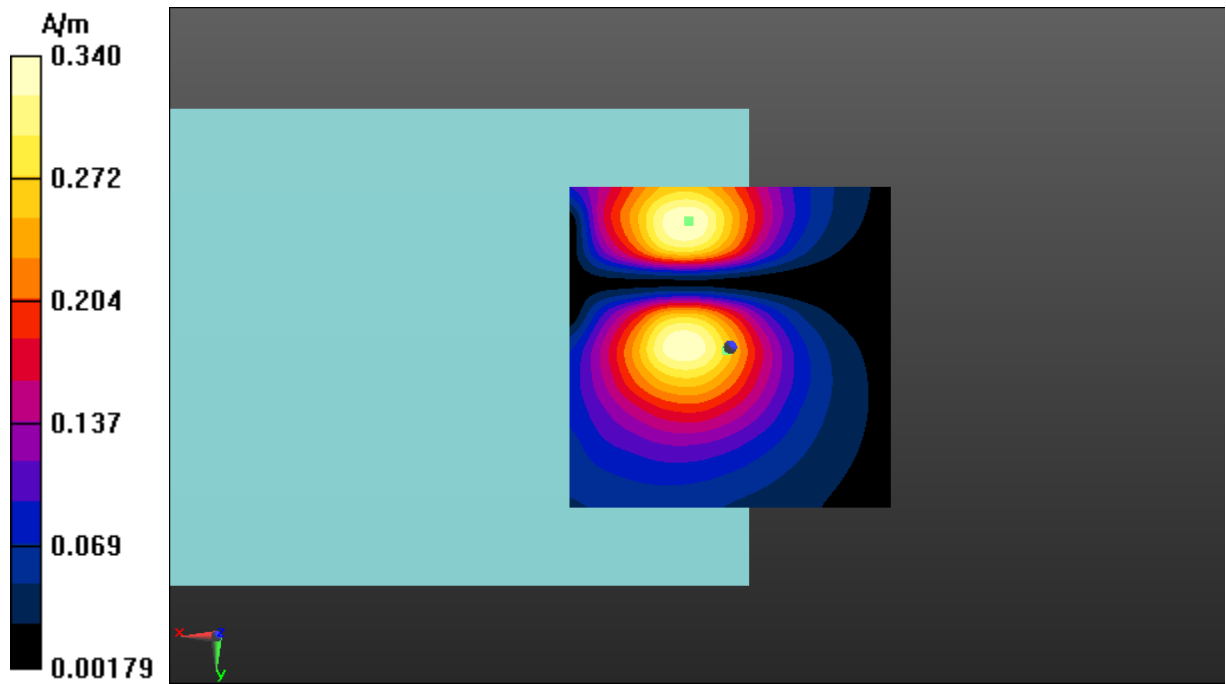

Fig A.43 T-Coil WLAN 5.8GHz-Y

ANNEX B: Frequency Response Curves

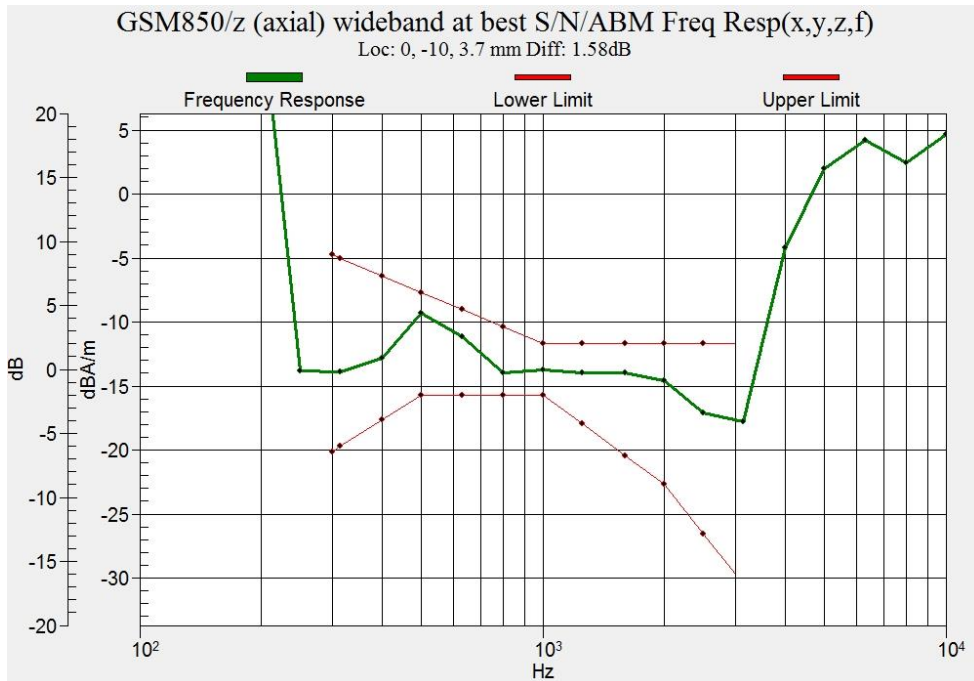

Figure B.1 Frequency Response of GSM850 (Ant.1)

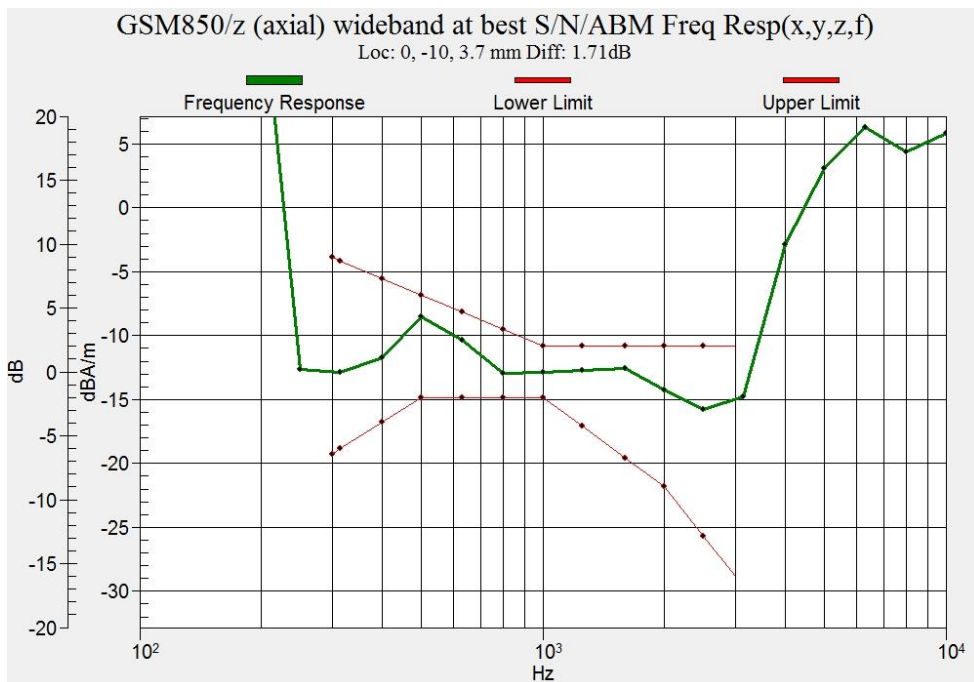

Figure B.2 Frequency Response of GSM850 (Ant.2)

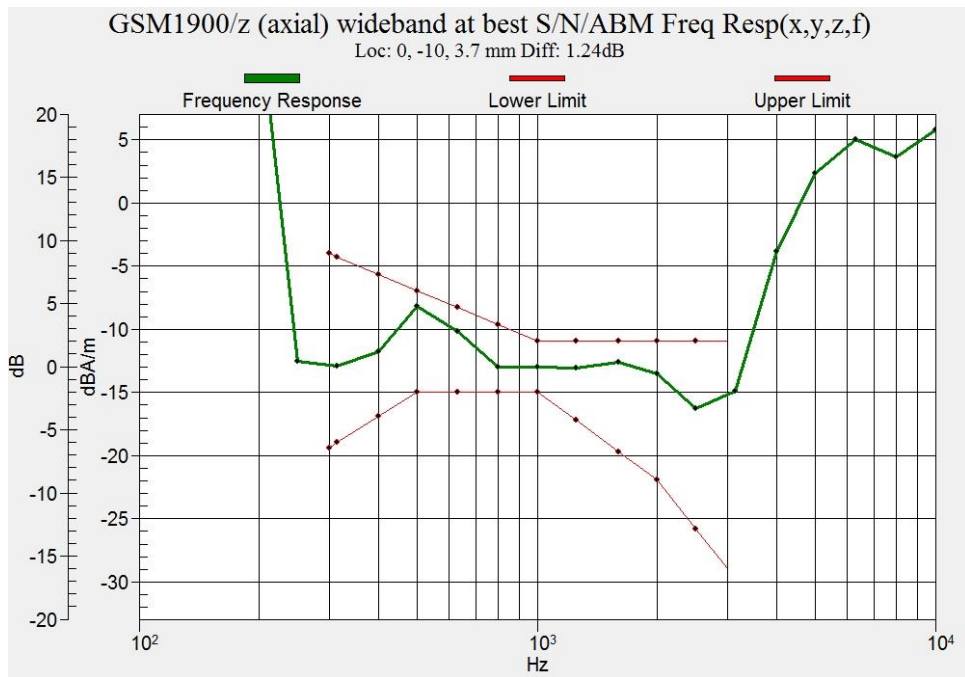

Figure B.3 Frequency Response of GSM1900 (Ant.0)

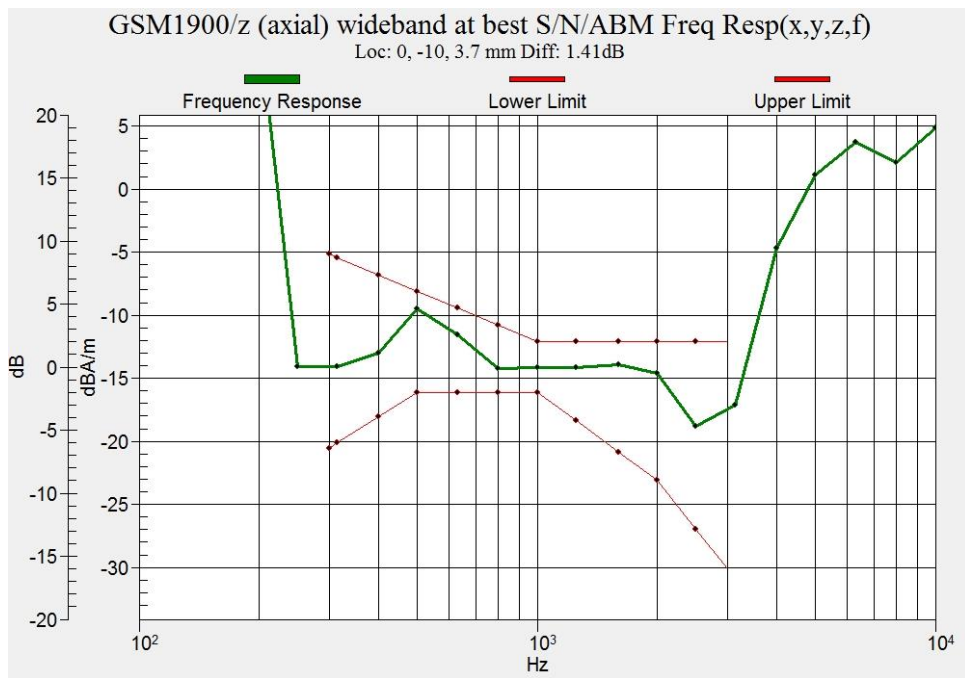

Figure B.4 Frequency Response of GSM1900 (Ant.2)

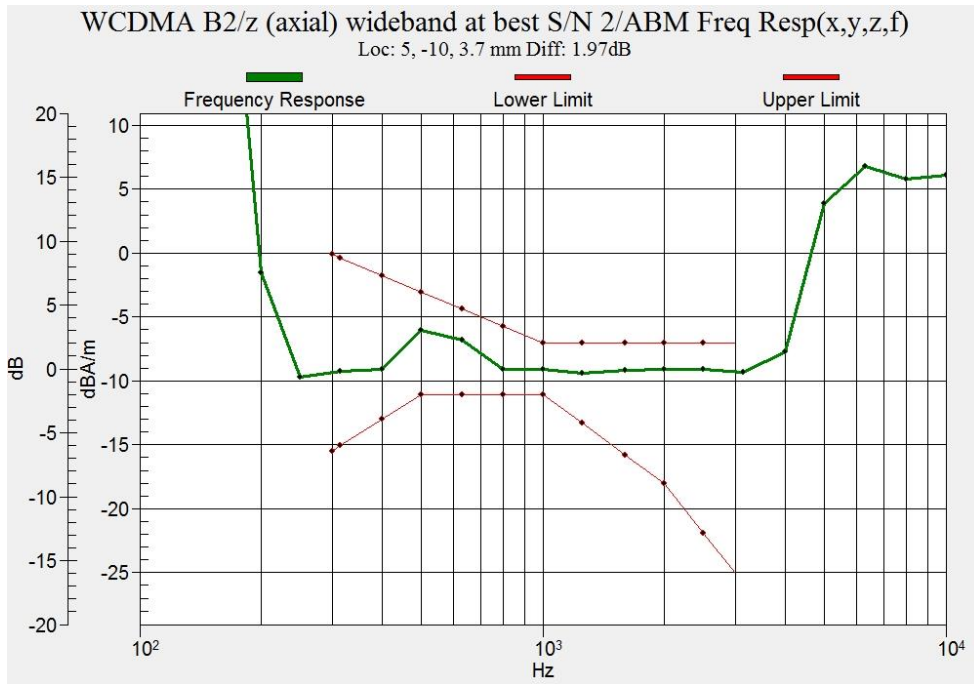

Figure B.5 Frequency Response of WCDMA Band 2 (Ant.0)

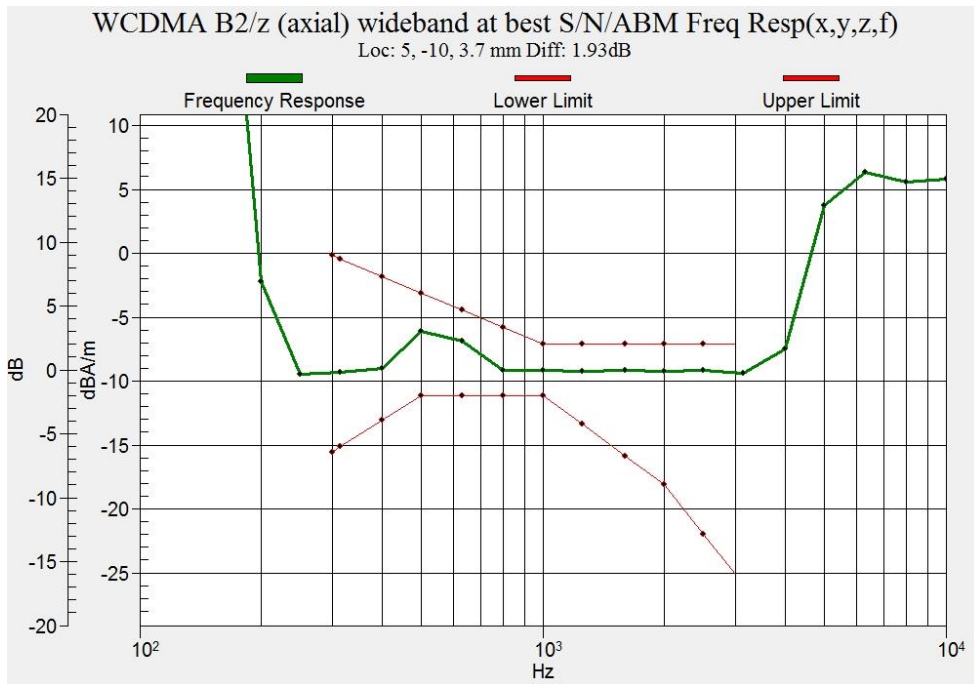

Figure B.6 Frequency Response of WCDMA Band 2 (Ant.2)

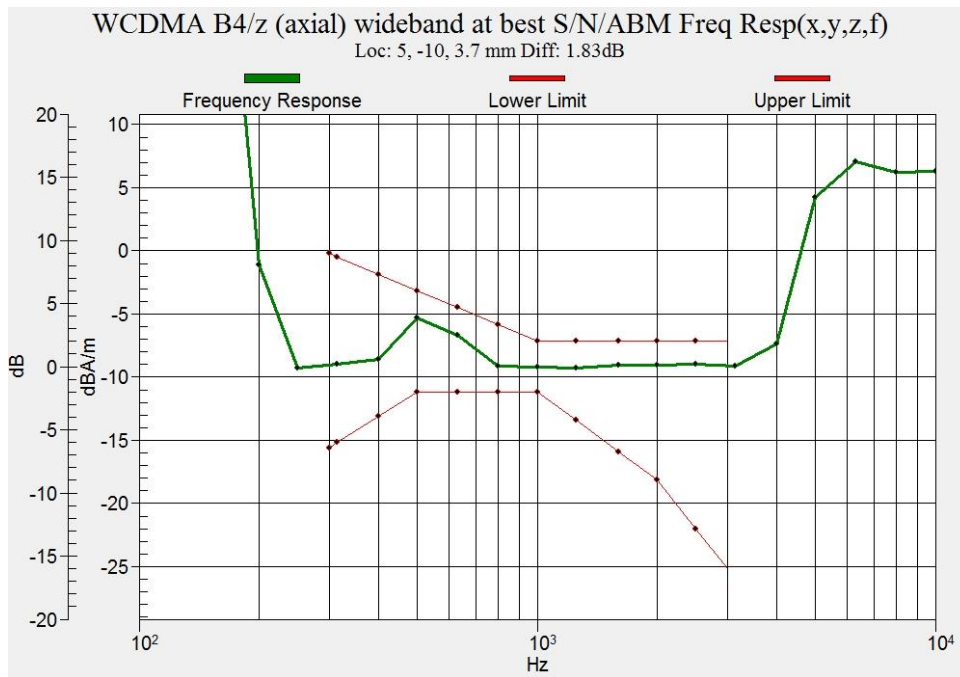

Figure B.7 Frequency Response of WCDMA Band 4 (Ant.0)

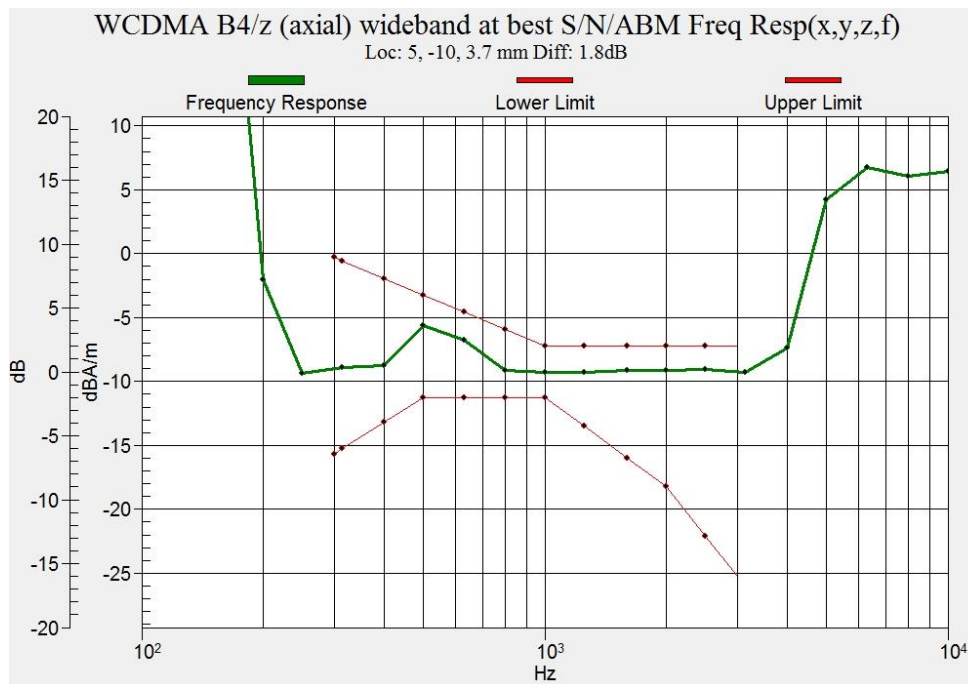

Figure B.8 Frequency Response of WCDMA Band 4 (Ant.2)

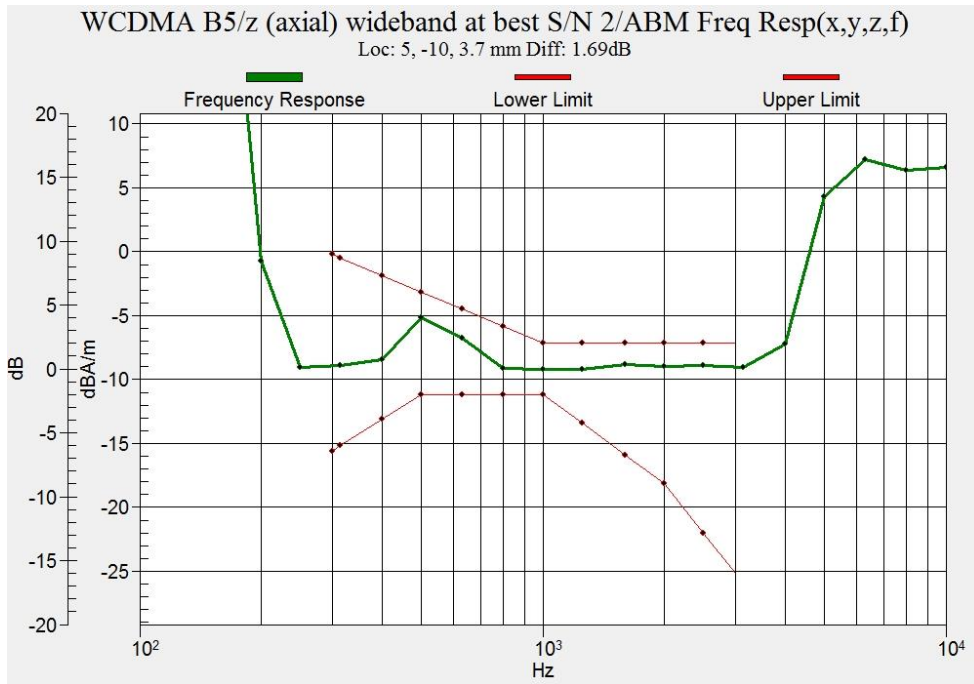

Figure B.9 Frequency Response of WCDMA Band 5 (Ant.1)

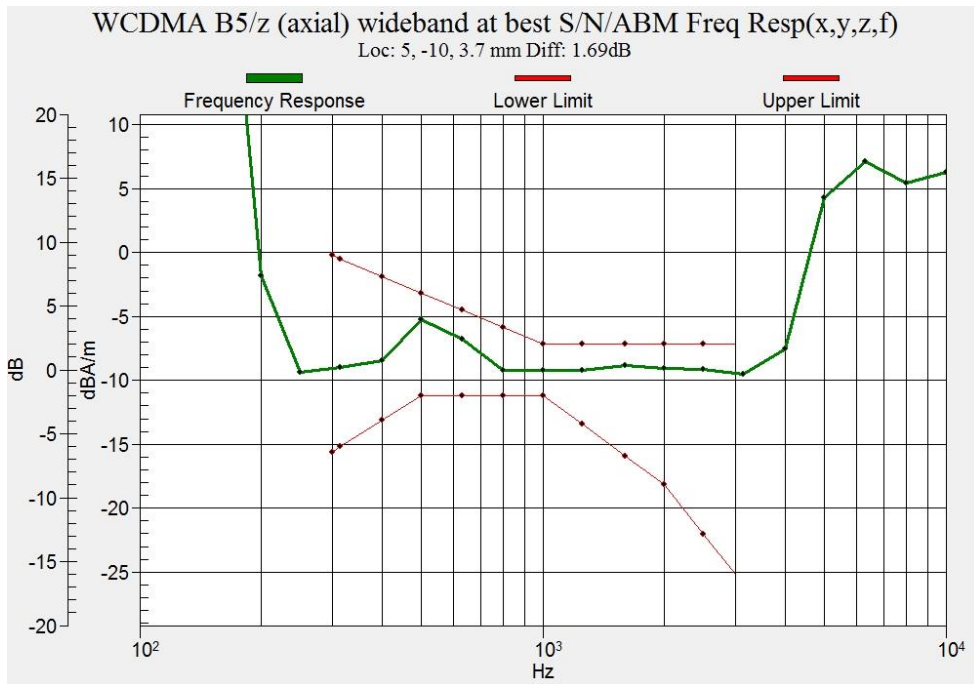

Figure B.10 Frequency Response of WCDMA Band 5 (Ant.2)

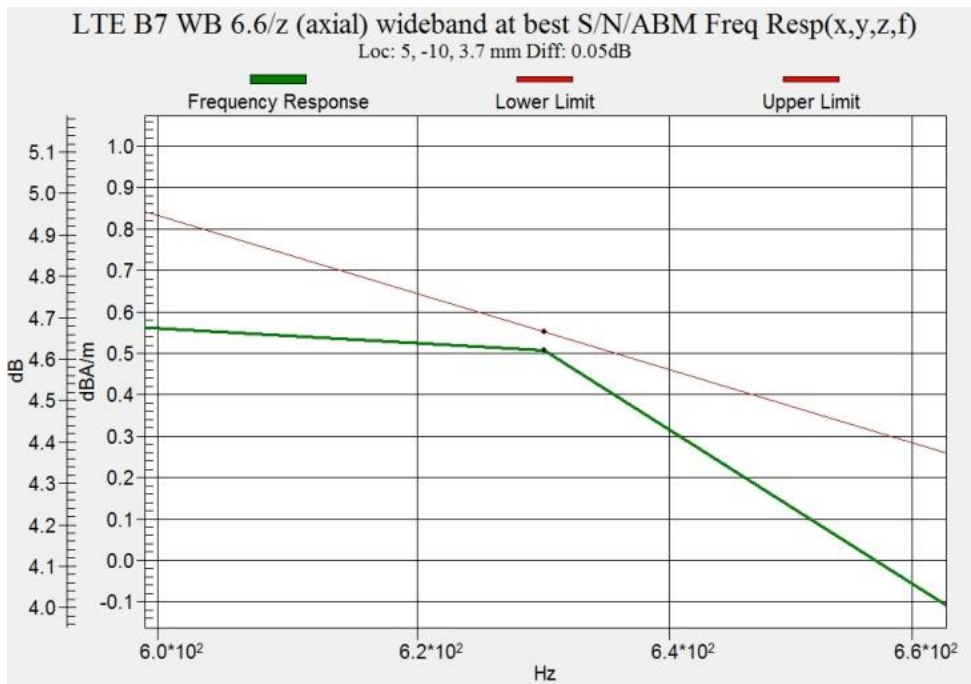
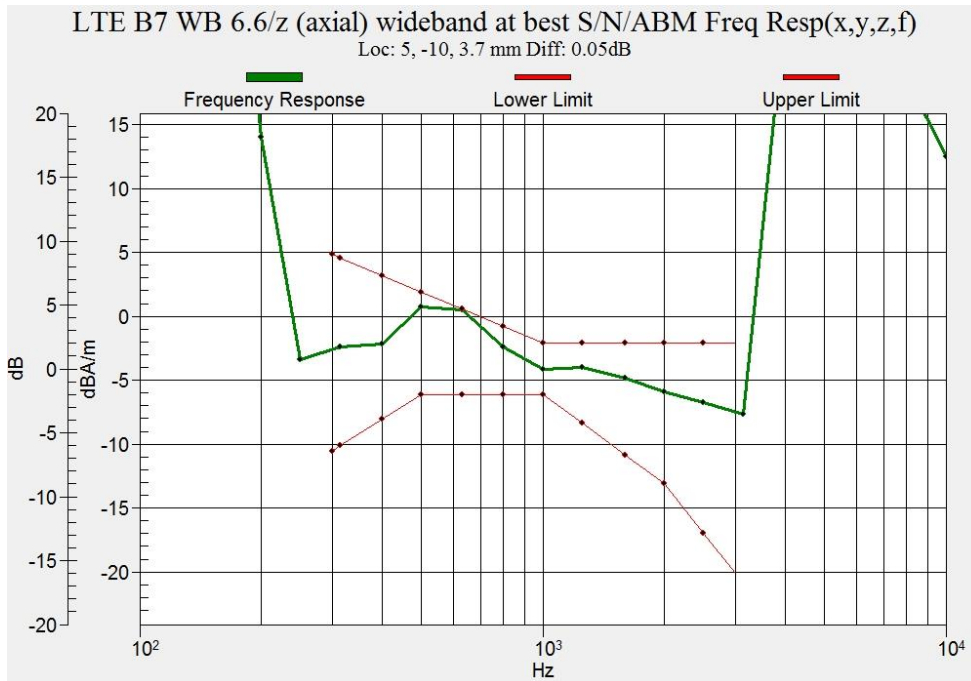

Figure B.11 Frequency Response of LTE Band 7 (Ant.0)

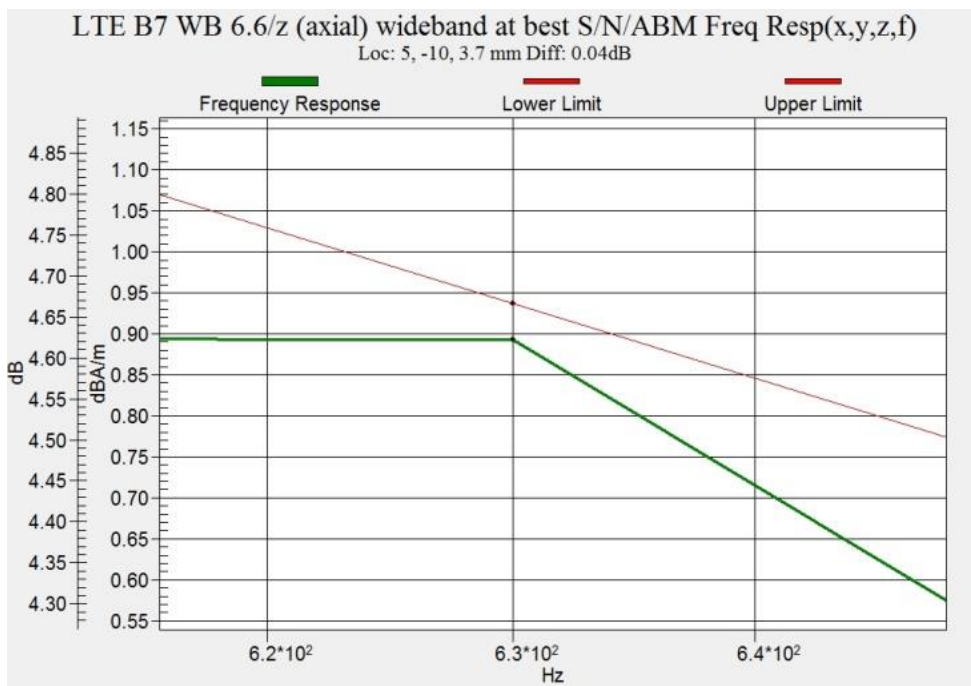
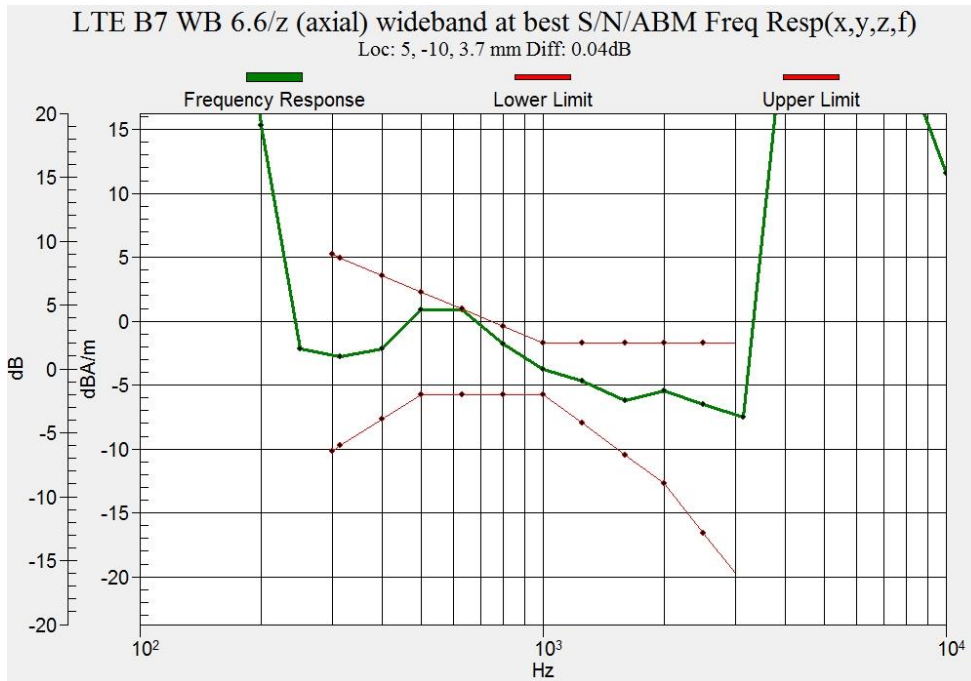

Figure B.12 Frequency Response of LTE Band 7 (Ant.2)

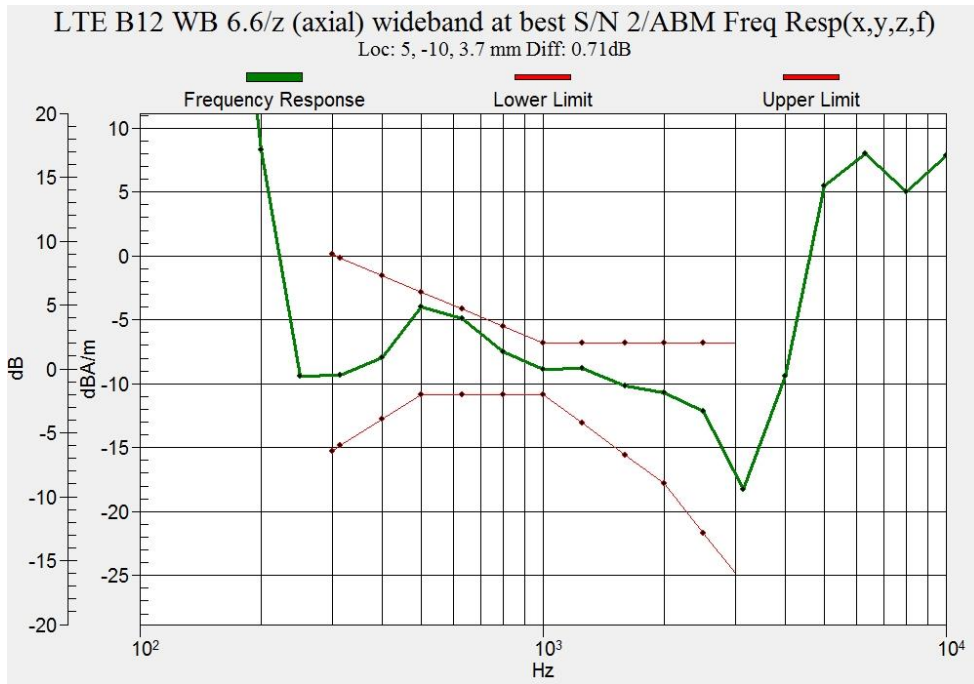

Figure B.13 Frequency Response of LTE Band 12 (Ant.1)

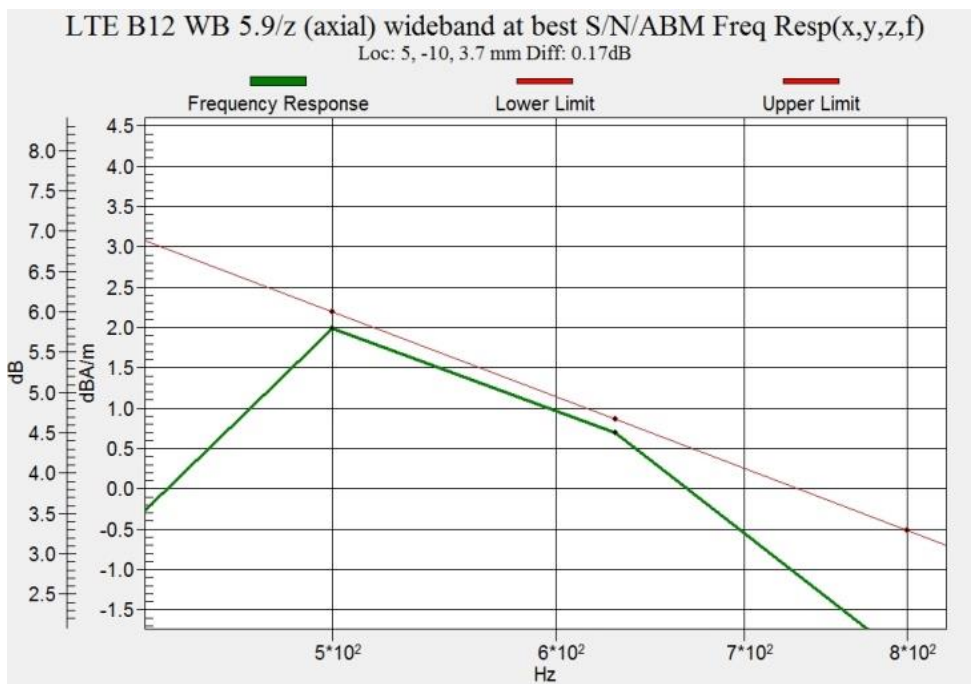

Figure B.14 Frequency Response of LTE Band 12 (Ant.2)

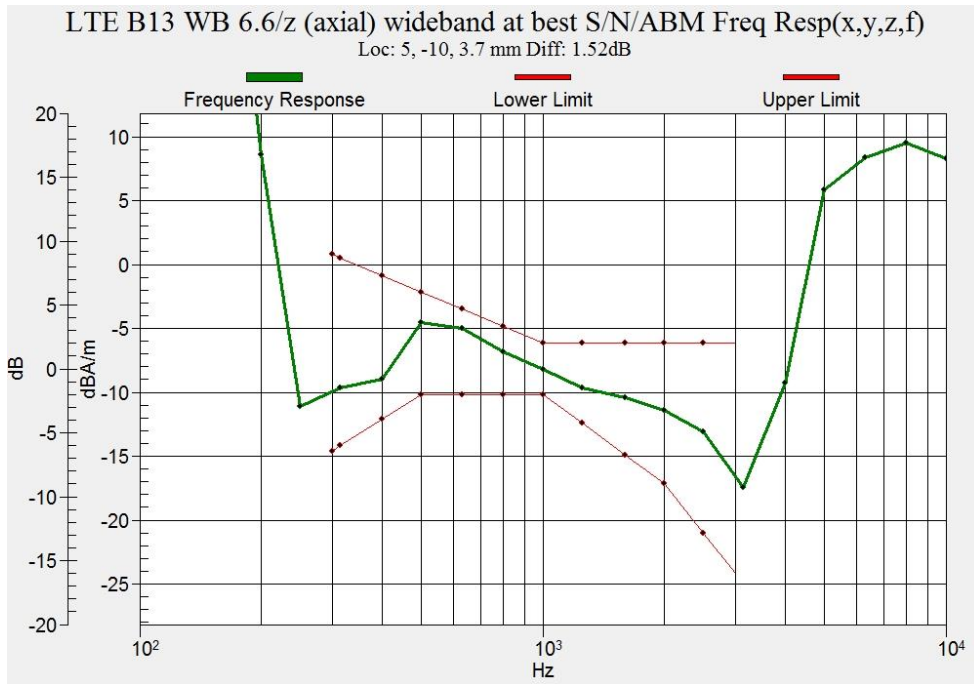

Figure B.15 Frequency Response of LTE Band 13 (Ant.1)

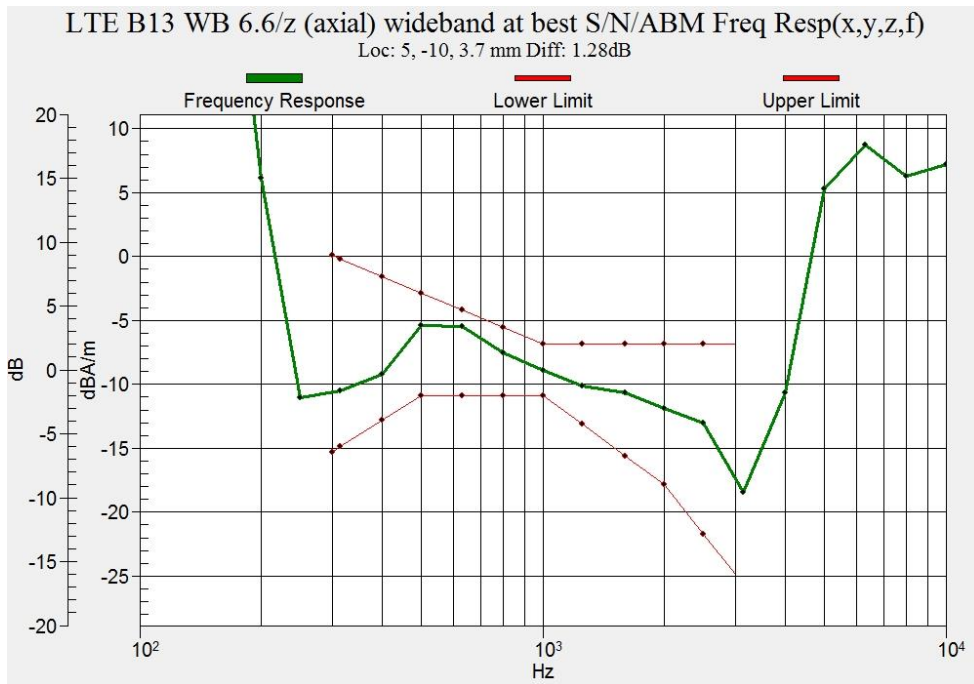

Figure B.16 Frequency Response of LTE Band 13 (Ant.2)

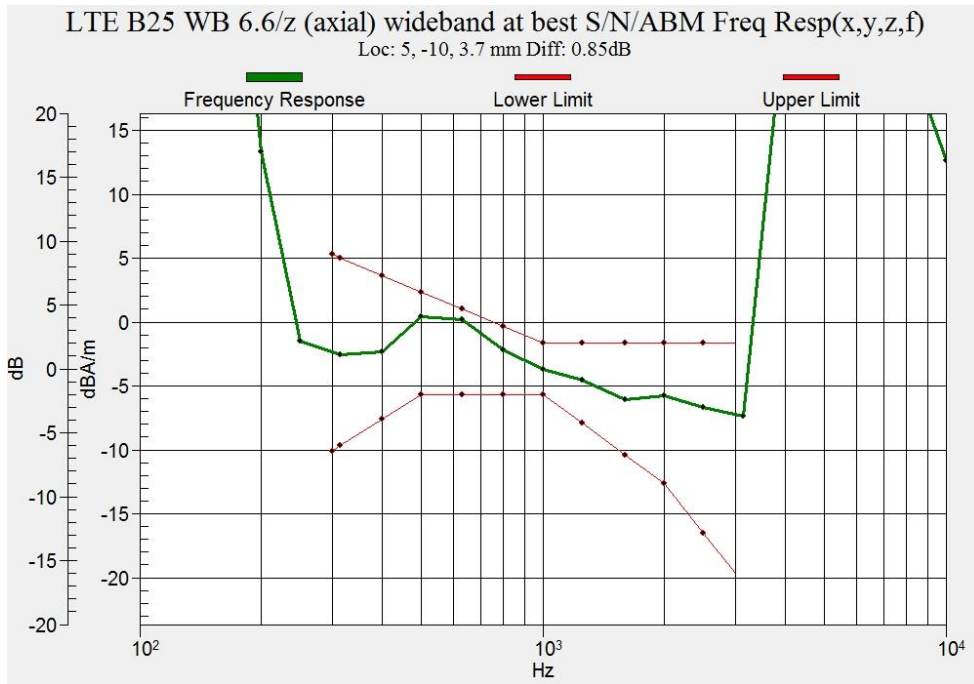

Figure B.17 Frequency Response of LTE Band 25 (Ant.0)

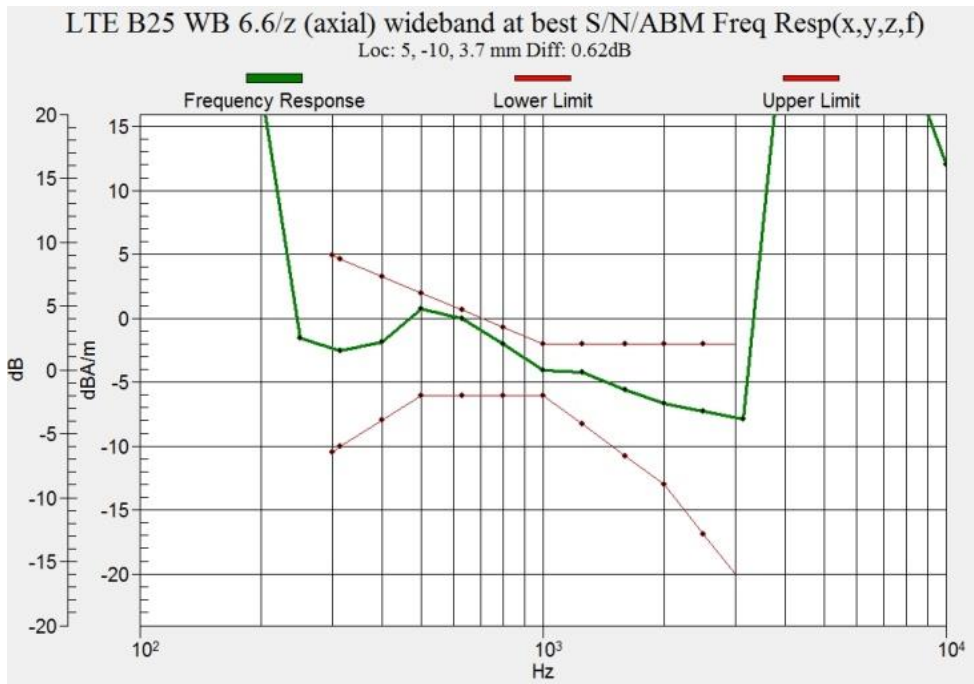

Figure B.18 Frequency Response of LTE Band 25 (Ant.2)

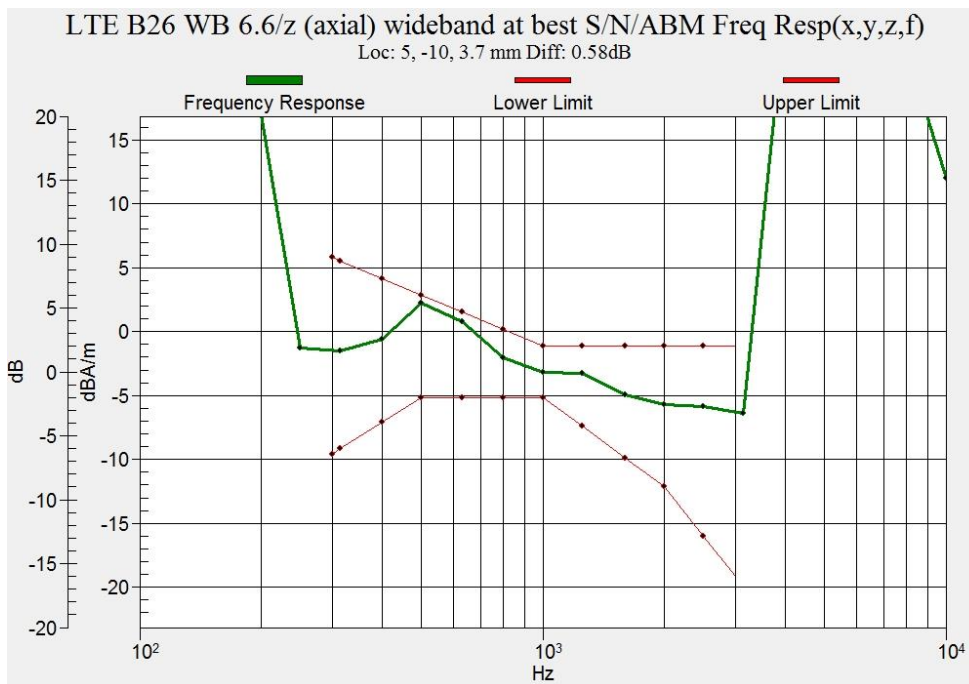

Figure B.19 Frequency Response of LTE Band 26 (Ant.1)

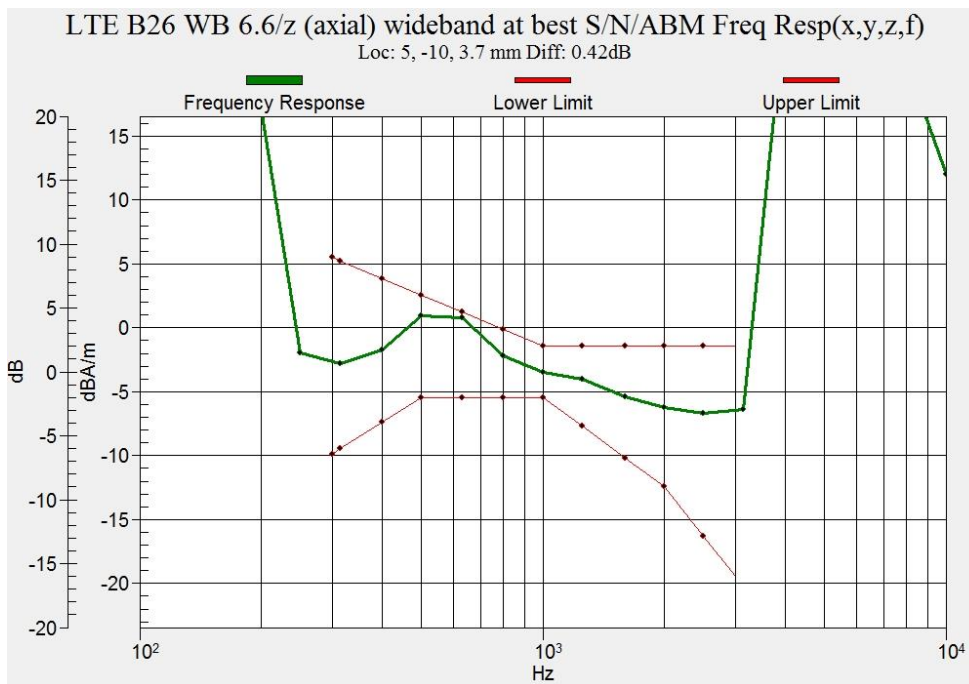

Figure B.20 Frequency Response of LTE Band 26 (Ant.2)

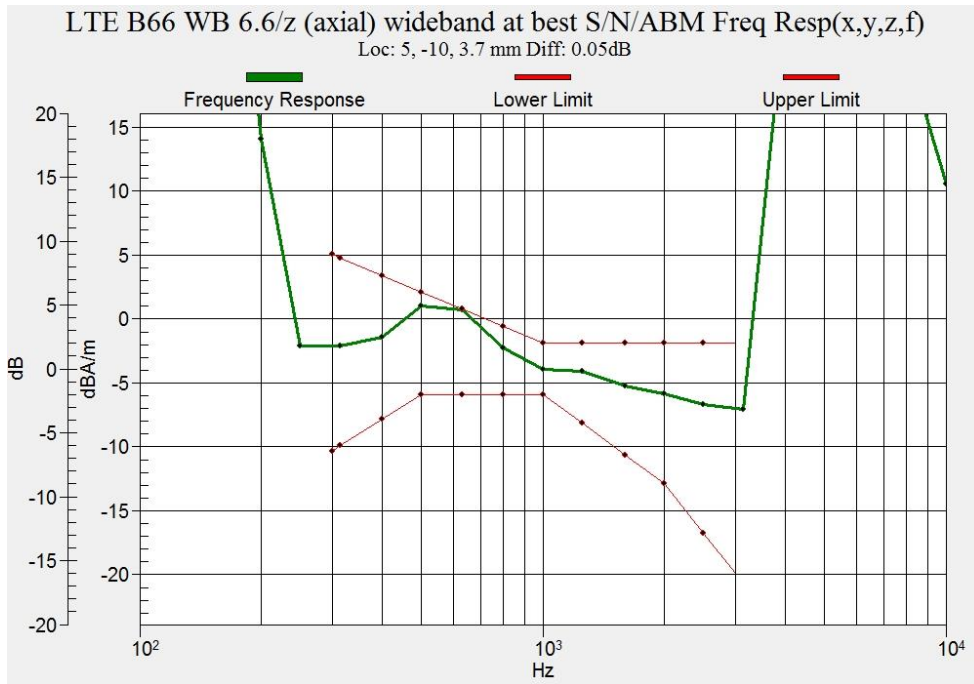

Figure B.21 Frequency Response of LTE Band 66 (Ant.0)

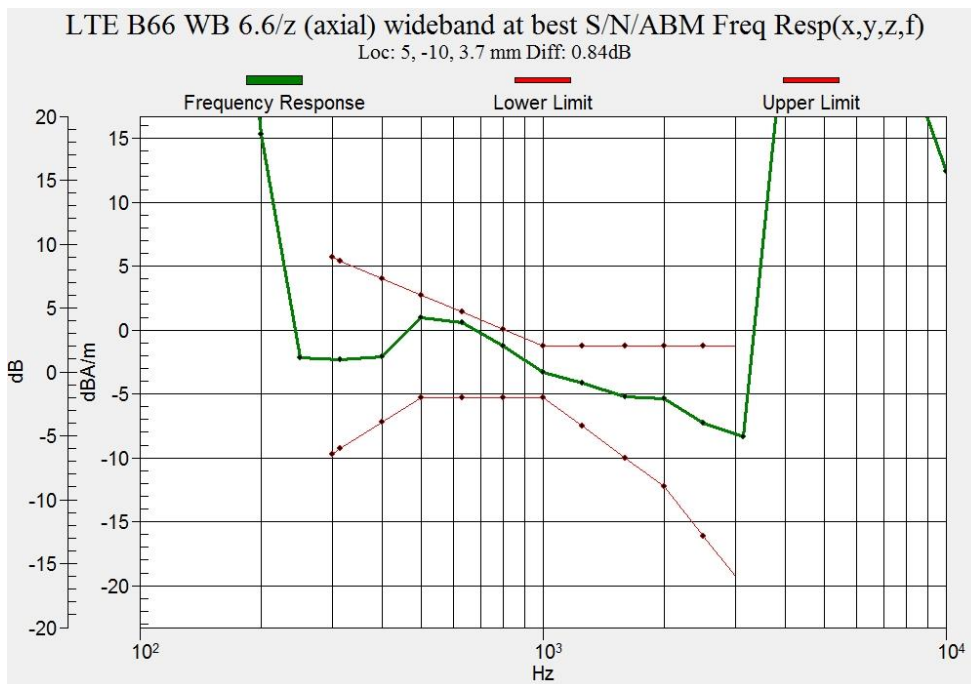

Figure B.22 Frequency Response of LTE Band 66 (Ant.2)



Figure B.23 Frequency Response of LTE Band 71 (Ant.1)