



Test Report No.: W7L-P22030013RF03



FCC TEST REPORT (PART 27)

| | |
|------------|---------------------------------------------|
| Applicant: | HMD Global Oy |
| Address: | Bertel Jungin aukio 9, 02600 Espoo, Finland |

| | |
|---------------------------|---------------------------------------------|
| Manufacturer or Supplier: | HMD Global Oy |
| Address: | Bertel Jungin aukio 9, 02600 Espoo, Finland |
| Product: | GSM/WCDMA/LTE Mobile Phone |
| Brand Name: | NOKIA |
| Model Name: | TA-1469 |
| FCC ID: | 2AJOTTA-1469 |
| Date of tests: | Mar. 28, 2022 ~ Apr. 11, 2022 |

The tests have been carried out according to the requirements of the following standard:

- FCC Part 27 ANSI/TIA/EIA-603-D
- FCC Part 2 ANSI/TIA/EIA-603-E ANSI C63.26-2015

CONCLUSION: The submitted sample was found to COMPLY with the test requirement

| | |
|--------------------------------------------------------|----------------------------------------------------|
| Prepared by Simon Wang Engineer / Mobile Department | Approved by Luke Lu Manager / Mobile Department |
| | |
| Date: Apr. 11, 2022 | Date: Apr. 11, 2022 |

This report is governed by, and incorporates by reference, CPS Conditions of Service as posted at the date of issuance of this report at <http://www.bureauveritas.com/home/about-us/our-business/cps/about-us/terms-conditions> and is intended for your exclusive use. Any copying or replication of this report to or for any other person or entity, or use of our name or trademark, is permitted only with our prior written permission. This report sets forth our findings solely with respect to the test samples identified herein. The results set forth in this report are not indicative or representative of the quality or characteristics of the lot from which a test sample was taken or any similar or identical product unless specifically and expressly noted. Our report includes all of the tests requested by you and the results thereof based upon the information that you provided to us. Measurement uncertainty is only provided upon request for accredited tests. You have 60 days from date of issuance of this report to notify us of any material error or omission caused by our negligence or if you require measurement uncertainty; provided, however, that such notice shall be in writing and shall specifically address the issue you wish to raise. A failure to raise such issue within the prescribed time shall constitute your unqualified acceptance of the completeness of this report, the tests conducted and the correctness of the report contents.



TABLE OF CONTENTS

| | |
|----------------------------------------------------------------|-----------|
| RELEASE CONTROL RECORD | 4 |
| 1 SUMMARY OF TEST RESULTS | 5 |
| 1.1 MEASUREMENT UNCERTAINTY | 6 |
| 1.2 TEST SITE AND INSTRUMENTS | 7 |
| 2 GENERAL INFORMATION | 8 |
| 2.1 GENERAL DESCRIPTION OF EUT..... | 8 |
| 2.2 CONFIGURATION OF SYSTEM UNDER TEST | 10 |
| 2.3 DESCRIPTION OF SUPPORT UNITS | 11 |
| 2.4 TEST ITEM AND TEST CONFIGURATION | 11 |
| 2.5 GENERAL DESCRIPTION OF APPLIED STANDARDS | 14 |
| 3 TEST TYPES AND RESULTS | 15 |
| 3.1 OUTPUT POWER MEASUREMENT | 15 |
| 3.1.1 LIMITS OF OUTPUT POWER MEASUREMENT | 15 |
| 3.1.2 TEST PROCEDURES | 15 |
| 3.1.3 TEST SETUP..... | 16 |
| 3.1.4 TEST RESULTS | 17 |
| 3.2 FREQUENCY STABILITY MEASUREMENT | 23 |
| 3.2.1 LIMITS OF FREQUENCY STABILITY MEASUREMENT | 23 |
| 3.2.2 TEST PROCEDURE..... | 23 |
| 3.2.3 TEST SETUP | 23 |
| 3.2.4 TEST RESULTS | 24 |
| 3.3 OCCUPIED BANDWIDTH MEASUREMENT | 25 |
| 3.3.1 LIMITS OF OCCUPIED BANDWIDTH MEASUREMENT | 25 |
| 3.3.2 TEST SETUP | 25 |
| 3.3.3 TEST PROCEDURES | 25 |
| 3.3.4 TEST RESULTS | 26 |
| 3.4 BAND EDGE MEASUREMENT..... | 27 |
| 3.4.1 LIMITS OF BAND EDGE MEASUREMENT | 27 |
| 3.4.2 TEST SETUP | 27 |
| 3.4.3 TEST PROCEDURES | 27 |
| 3.4.4 TEST RESULTS | 29 |
| 3.5 CONDUCTED SPURIOUS EMISSIONS..... | 30 |
| 3.5.1 LIMITS OF CONDUCTED SPURIOUS EMISSIONS MEASUREMENT | 30 |
| 3.5.2 TEST PROCEDURE | 30 |
| 3.5.3 TEST SETUP | 30 |
| 3.5.4 TEST RESULTS | 31 |
| 3.6 RADIATED EMISSION MEASUREMENT | 32 |
| 3.6.1 LIMITS OF RADIATED EMISSION MEASUREMENT | 32 |
| 3.6.2 TEST PROCEDURES | 32 |
| 3.6.3 DEVIATION FROM TEST STANDARD | 32 |
| 3.6.4 TEST SETUP | 33 |
| 3.6.5 TEST RESULTS | 35 |
| 3.7 PEAK TO AVERAGE RATIO | 49 |
| 3.7.1 LIMITS OF PEAK TO AVERAGE RATIO MEASUREMENT | 49 |
| 3.7.2 TEST SETUP | 49 |
| 3.7.3 TEST PROCEDURES | 49 |
| 3.7.4 TEST RESULTS | 50 |
| 4 INFORMATION ON THE TESTING LABORATORIES | 51 |



**BUREAU
VERITAS**

Test Report No.: W7L-P22030013RF03

5 MODIFICATIONS RECORDERS FOR ENGINEERING CHANGES TO THE EUT BY THE LAB... 52

APPENDIX 53

PEAK-TO-AVERAGE RATIO(CCDF)..... 53

 TEST RESULT 53

 TEST GRAPHS 55

26DB BANDWIDTH AND OCCUPIED BANDWIDTH 72

 TEST RESULT 72

 TEST GRAPHS 73

BAND EDGE 82

 TEST RESULT 82

 TEST GRAPHS 83

CONDUCTED SPURIOUS EMISSION..... 94

 TEST RESULT 94

 TEST GRAPHS 95

FREQUENCY STABILITY112

 TEST RESULT112



Test Report No.: W7L-P22030013RF03

RELEASE CONTROL RECORD

| ISSUE NO. | REASON FOR CHANGE | DATE ISSUED |
|-------------------|-------------------|---------------|
| W7L-P22030013RF03 | Original release | Apr. 11, 2022 |



1 SUMMARY OF TEST RESULTS

The EUT has been tested according to the following specifications:

| APPLIED STANDARD: FCC PART 27 & PART 2 | | |
|----------------------------------------|--------------------------------------------------|------------|
| STANDARD SECTION | TEST TYPE AND LIMIT | RESULT |
| §2.1046 | Conducted Output Power | Compliance |
| §27.50(h)(2) | Equivalent Isotropically Radiated Power (Band 7) | Compliance |
| §2.1055 §27.54 | Frequency Stability | Compliance |
| §2.1049 | Occupied Bandwidth | Compliance |
| §2.1051 §27.53(m)(4)(6) | Conducted Band Edge Measurements (Band 7) | Compliance |
| §2.1051 §27.53(m)(4)(6) | Conducted Spurious Emissions (Band 7) | Compliance |
| §2.1053 §27.53(m)(4)(6) | Radiated Spurious Emissions (Band 7) | Compliance |

1.1 MEASUREMENT UNCERTAINTY

Where relevant, the following measurement uncertainty levels have been estimated for tests performed on the EUT as specified in CISPR 16-4-2:

| MEASUREMENT | UNCERTAINTY |
|----------------------------------------------------|-------------|
| Frequency Stability | ±76.97Hz |
| Radiated emissions & Radiated Power (30MHz~1GMHz) | ±4.98dB |
| Radiated emissions & Radiated Power (1GMHz ~6GMHz) | ±4.70dB |
| Radiated emissions (6GMHz ~18GMHz) | ±4.60dB |
| Radiated emissions (18GMHz ~40GMHz) | ±4.12dB |
| Conducted emissions | ±4.01dB |
| Occupied Channel Bandwidth | ±43.58KHz |
| Conducted Output power | ±2.06dB |
| Band Edge Measurements | ±4.70dB |

This uncertainty represents an expanded uncertainty expressed at approximately the 95% confidence level using a coverage factor of k=2.

1.2 TEST SITE AND INSTRUMENTS

| Equipment | Manufacturer | Model No. | Serial No. | Last Cal. | Next Cal. |
|---------------------------------------------|------------------|---------------------------------|-------------------------------------|-------------|-------------|
| MXE EMI Receiver | KEYSIGHT | N9038A-544 | MY54450026 | Apr. 22,21 | Apr. 21,22 |
| EXA Signal Analyzer | KEYSIGHT | N9010A-544 | MY54510355 | Jun. 03,21 | Jun. 02,22 |
| Loop Antenna | Schwarzbeck | FMZB 1519B | 00173 | Sep.05,21 | Sep.04,22 |
| Bilog Antenna | ETS-LINDGRE N | 3143B | 00161964 | Feb. 24,22 | Feb. 23,23 |
| Horn Antenna | ETS-LINDGRE N | 3117 | 00168692 | Mar. 06,22 | Mar. 05,23 |
| Horn Antenna (18GHz-40GHz) | N/A | QWH-SL-18-40-K- SG/QMS-00361 | 15433 | Aug. 25, 21 | Aug. 24, 22 |
| Radio Communication Analyzer | ANRITSU | MT8820C | 6201465426 | Feb. 15,22 | Feb. 14,23 |
| Signal Pre-Amplifier | EMSI | EMC 9135 | 980249 | Jun. 02,21 | Jun. 01,22 |
| Signal Pre-Amplifier | EMSI | EMC 012645B | 980257 | Jun. 03,21 | Jun. 02,22 |
| Signal Pre-Amplifier | EMSI | EMC 184045B | 980259 | Apr. 22,21 | Apr. 21,22 |
| 3m Semi-anechoic Chamber | ETS-LINDGRE N | 9m*6m*6m | Euroshieldpn- CT0001143-121 6 | May. 19,20 | May. 18,23 |
| Test Software | E3 | V 9.160323 | N/A | N/A | N/A |
| Test Software | ADT | ADT_Radiated_V 7.6.15.9.2 | N/A | N/A | N/A |
| 10dB Attenuator | JFW/USA | 50HF-010-SMA | 1505 | Jun. 03,21 | Jun. 02,22 |
| Power Meter | Anritsu | N1914A | MY52180044 | Feb.19,22 | Feb.18,23 |
| Power Sensor | Agilent | E9304A H18 | MY52050011 | Feb.20,22 | Feb.19,23 |
| Temperature Chamber | ESPEC | SH-242 | 93000855 | Jun. 02,21 | Jun. 01,22 |
| MXG Analog Microvave Signal Generator | KEYSIGHT | N5183A | MY50143024 | Mar. 04,22 | Mar. 03,23 |
| Power Divider | MCLI/USA | PS2-15 | 24880 | N/A | N/A |

- NOTE:**
1. The calibration interval of the above test instruments is 12 months or 36 months and the calibrations are traceable to CEPREI/CHINA, GRGT/CHINA and NIM/CHINA.
 2. The test was performed in 3m Semi-anechoic Chamber and RF Oven Room.
 3. The horn antenna is used only for the measurement of emission frequency above 1GHz if tested.
 4. The FCC Site Registration No. is 525120; The Designation No. is CN1171.

2 GENERAL INFORMATION

2.1 GENERAL DESCRIPTION OF EUT

| | | |
|------------------------------|---------------------------------------------------------------|-----------------------|
| PRODUCT | GSM/WCDMA/LTE Mobile Phone | |
| BRAND NAME | NOKIA | |
| MODEL NAME | TA-1469 | |
| NOMINAL VOLTAGE | 5.0Vdc(adapter or host equipment) 3.8Vdc (Li-ion, battery) | |
| MODULATION TECHNOLOGY | LTE | QPSK, 16QAM |
| FREQUENCY RAN | LTE Band 7 Channel Bandwidth: 5MHz | 2502.5MHz ~ 2567.5MHz |
| | LTE Band 7 Channel Bandwidth: 10MHz | 2505MHz ~ 2565MHz |
| | LTE Band 7 Channel Bandwidth: 15MHz | 2507.5MHz ~ 2562.5MHz |
| | LTE Band 7 Channel Bandwidth: 20MHz | 2510MHz ~ 2560MHz |
| MAX. EIRP POWER | LTE Band 7 Channel Bandwidth: 5MHz | 334.97mW |
| | LTE Band 7 Channel Bandwidth: 10MHz | 334.2mW |
| | LTE Band 7 Channel Bandwidth: 15MHz | 337.29mW |
| | LTE Band 7 Channel Bandwidth: 20MHz | 338.84mW |
| EMISSION DESIGNATOR | LTE Band 7 Channel Bandwidth: 5MHz | QPSK: 4M50G7D |
| | | 16QAM: 4M50W7D |
| | LTE Band 7 Channel Bandwidth: 10MHz | QPSK:8M98G7D |
| | | 16QAM: 8M98W7D |
| | LTE Band 7 Channel Bandwidth: 15MHz | QPSK: 13M5G7D |
| | | 16QAM: 13M5W7D |
| | LTE Band 7 Channel Bandwidth: 20MHz | QPSK: 18M0G7D |
| | | 16QAM: 18M0W7D |
| ANTENNA TYPE | Fixed Internal Antenna with 2 dBi gain for LTE7 | |
| HW VERSION | FF618-MB-V0.2 | |



**BUREAU
VERITAS**

Test Report No.: W7L-P22030013RF03

| | |
|----------------------------|------------------------|
| SW VERSION | 0.2214.11.06 |
| I/O PORTS | Refer to user's manual |
| CABLE SUPPLIED | N/A |
| EXTREME TEMPERATURE | -10-55 °C |
| EXTREME VOLTAGE | 3.38V - 4.35V |

NOTE:

1. For a more detailed features description, please refer to the manufacturer's specifications or the user's manual.
2. For the test results, the EUT had been tested with all conditions. But only the worst case was shown in test report.

List of Accessory:

| ACCESSORIES | BRAND | MANUFACTURER | MODEL | SPECIFICATION |
|--------------------|--------------|--------------------------------------------------------|--------------|----------------------------------------------|
| Battery | NOKIA | HuNan ADF Alternative Energy Technology Co., Ltd | BL-L4E | Capacity: 3.80 Vdc, 1450mAh |
| AC Adapter | NOKIA | Shenzhen Baijunda Electronic Co., Ltd | AC-18U | I/P: 100-240Vac, 0.1A, O/P: 5.0Vdc, 0.55A |

2.2 CONFIGURATION OF SYSTEM UNDER TEST FOR RADIATION EMISSION TEST

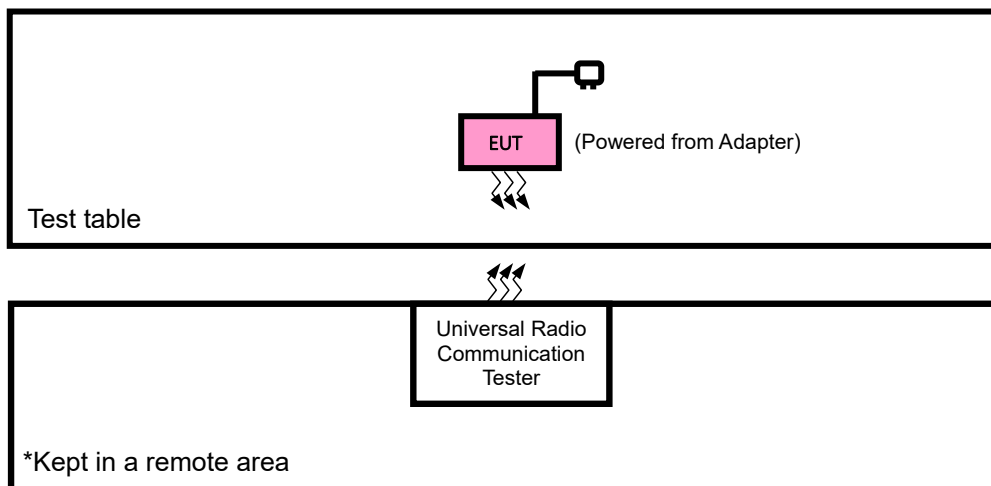

2.3 DESCRIPTION OF SUPPORT UNITS

The EUT has been tested as an independent unit together with other necessary accessories or support units. The following support units or accessories were used to form a representative test configuration during the tests.

| NO. | PRODUCT | BRAND | MODEL NO. | SERIAL NO. | FCC ID |
|-----|----------------------------|---------------|-----------|------------|--------|
| 1 | DC source | LONG WEI | PS-6403D | 010934269 | N/A |
| 2 | Base station R&S CMW500 | Rohde&Schwarz | CMW500 | 153084 | N/A |

| NO. | SIGNAL CABLE DESCRIPTION OF THE ABOVE SUPPORT UNITS |
|-----|-----------------------------------------------------|
| 1 | DC Line: Unshielded, Detachable 1.8m |

2.4 TEST ITEM AND TEST CONFIGURATION

Pre-Scan has been conducted to determine the worst-case mode from all possible combinations between available modulations, data rates, XYZ axis and antenna ports. The worst case was found when positioned on Y-plane for EIRP and X-axis for radiated emission. Following channel(s) was (were) selected for the final test as listed below:

| EUT CONFIGURE MODE | DESCRIPTION |
|--------------------|-----------------------------------------|
| A | EUT + Adapter + USB Cable with LTE link |
| B | EUT + Battery with LTE link |

LTE BAND 7 MODE

| EUT CONFIGURE MODE | TEST ITEM | AVAILABLE CHANNEL | TESTED CHANNEL | CHANNEL BANDWIDT H | MODULATION | MODE | | |
|--------------------|---------------------|-------------------|-----------------------|--------------------|---------------------|----------------------|-------------|--------------------|
| A | EIRP | 20775 to 21425 | 20775, 21100, 21425 | 5MHz | QPSK, 16QAM | 1 RB / 0 RB Offset | | |
| | | 20800 to 21400 | 20800, 21100, 21400 | 10MHz | QPSK, 16QAM | 1 RB / 0RB Offset | | |
| | | 20825 to 21375 | 20825, 21100, 21375 | 15MHz | QPSK, 16QAM | 1 RB / 0 RB Offset | | |
| | | 20850 to 21350 | 20850, 21100, 21350 | 20MHz | QPSK, 16QAM | 1 RB / 0 RB Offset | | |
| B | FREQUENCY STABILITY | 20775 to 21425 | 20775, 21100, 21425 | 5MHz | QPSK, 16QAM | 25 RB / 0 RB Offset | | |
| | | 20800 to 21400 | 20800, 21100, 21400 | 10MHz | QPSK, 16QAM | 50 RB / 0 RB Offset | | |
| | | 20825 to 21375 | 20825, 21100, 21375 | 15MHz | QPSK, 16QAM | 75 RB / 0 RB Offset | | |
| | | 20850 to 21350 | 20850, 21100, 21350 | 20MHz | QPSK, 16QAM | 100 RB / 0 RB Offset | | |
| A | OCCUPIED BANDWIDTH | 20775 to 21425 | 20775, 21100, 21425 | 5MHz | QPSK, 16QAM | 25 RB / 0 RB Offset | | |
| | | 20800 to 21400 | 20800, 21100, 21400 | 10MHz | QPSK, 16QAM | 50 RB / 0 RB Offset | | |
| | | 20825 to 21375 | 20825, 21100, 21375 | 15MHz | QPSK, 16QAM | 75 RB / 0 RB Offset | | |
| | | 20850 to 21350 | 20850, 21100, 21350 | 20MHz | QPSK, 16QAM | 100 RB / 0 RB Offset | | |
| A | BAND EDGE | 20775 to 21425 | 20775 | 5MHz | QPSK, 16QAM | 1 RB / 0 RB Offset | | |
| | | | 21425 | 5MHz | QPSK, 16QAM | 25 RB / 0 RB Offset | | |
| | | 20800 to 21400 | 20800 | 10MHz | QPSK, 16QAM | 1 RB / 24 RB Offset | | |
| | | | 21400 | 10MHz | QPSK, 16QAM | 25 RB / 0 RB Offset | | |
| | | 20825 to 21375 | 20825 | 15MHz | QPSK, 16QAM | 1 RB / 0 RB Offset | | |
| | | | 21375 | 15MHz | QPSK, 16QAM | 75 RB / 0 RB Offset | | |
| | | 20850 to 21350 | 20850 | 20MHz | QPSK, 16QAM | 1 RB / 74 RB Offset | | |
| | | | 21350 | 20MHz | QPSK, 16QAM | 75 RB / 0 RB Offset | | |
| | | A | CONDCUDE TED EMISSION | 20775 to 21425 | 20775, 21100, 21425 | 5MHz | QPSK, 16QAM | 1 RB / 0 RB Offset |
| | | | | 20800 to 21400 | 20800, 21100, 21400 | 10MHz | QPSK, 16QAM | 1 RB / 0RB Offset |
| | | | | 20825 to 21375 | 20825, 21100, 21375 | 15MHz | QPSK, 16QAM | 1 RB / 0 RB Offset |
| | | | | 20850 to 21350 | 20850, 21100, 21350 | 20MHz | QPSK, 16QAM | 1 RB / 0 RB Offset |
| A | RADIATED EMISSION | 20775 to 21425 | 21100 | 5MHz | QPSK | 1 RB / 0 RB Offset | | |
| | | 20800 to 21400 | 20800, 21100, 21400 | 10MHz | QPSK | 1 RB / 0 RB Offset | | |
| | | 20825 to 21375 | 21100 | 15MHz | QPSK | 1 RB / 0 RB Offset | | |
| | | 20850 to 21350 | 21100 | 20MHz | QPSK | 1 RB / 0 RB Offset | | |

Note: This device was tested under all bandwidths, RB configurations and modulations. The worst case was found in QPSK modulation.



Test Report No.: W7L-P22030013RF03

TEST CONDITION:

| TEST ITEM | ENVIRONMENTAL CONDITIONS | INPUT POWER | TESTED BY |
|-----------------------|--------------------------|--------------------|-----------|
| ERP&EIRP | 23deg. C, 70%RH | DC 5V By Adapter | Jace Hu |
| FREQUENCY STABILITY | 23deg. C, 70%RH | DC 3.8V By Battery | James Fu |
| OCCUPIED BANDWIDTH | 23deg. C, 70%RH | DC 5V By Adapter | James Fu |
| BAND EDGE | 23deg. C, 70%RH | DC 5V By Adapter | James Fu |
| CONDCUDED EMISSION | 23deg. C, 70%RH | DC 5V By Adapter | James Fu |
| RADIATED EMISSION | 23deg. C, 70%RH | DC 5V By Adapter | Jace Hu |
| PEAK TO AVERAGE RATIO | 23deg. C, 70%RH | DC 5V By Adapter | James Fu |



Test Report No.: W7L-P22030013RF03

2.5 GENERAL DESCRIPTION OF APPLIED STANDARDS

The EUT is a RF product. According to the specifications of the manufacturer, it must comply with the requirements of the following standards:

FCC 47 CFR Part 2

FCC 47 CFR Part 27

KDB 971168 D01 Power Meas License Digital Systems v03r01

ANSI/TIA/EIA-603-D

ANSI/TIA/EIA-603-E

ANSI C63.26-2015

NOTE: All test items have been performed and recorded as per the above standards.

3 TEST TYPES AND RESULTS

3.1 OUTPUT POWER MEASUREMENT

3.1.1 LIMITS OF OUTPUT POWER MEASUREMENT

The radiated peak output power shall be according to the specific rule Part 27.50(h)(2) that “User stations are limited to 2 watts” and 27.50(i) specific that “Peak transmit power must be measure over any interval of continuous transmission using instrumentation calibration in terms of rms-equivalent voltage.”

3.1.2 TEST PROCEDURES

EIRP MEASUREMENT:

Per KDB 971168 D01 Power Meas License Digital Systems v03r01 or subclause 5.2.5.5 of ANSI C63.26-2015, the relevant equation for determining the ERP or EIRP from the conducted RF output power measured using the guidance provided above is:

$$\text{ERP or EIRP} = P_{\text{Meas}} + G_{\text{T}} - L_{\text{c}}$$

Where:

ERP or EIRP = effective radiated power or equivalent isotropically radiated power, respectively
(expressed in the same units as P_{Meas} , typically dBW or dBm);

P_{Meas} = measured transmitter output power or PSD, in dBm or dBW;

G_{T} = gain of the transmitting antenna, in dBd (ERP) or dBi (EIRP);

L_{c} = signal attenuation in the connecting cable between the transmitter and antenna, in dB.

CONDUCTED POWER MEASUREMENT:

- a. The EUT was set up for the maximum power with LTE link data modulation and link up with simulator.
- b. Set the EUT to transmit under low, middle and high channel and record the power level shown on simulator.



Test Report No.: W7L-P22030013RF03

3.1.3 TEST SETUP

CONDUCTED POWER MEASUREMENT:

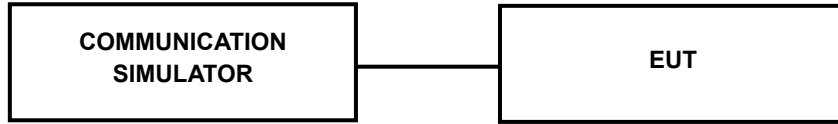

For the actual test configuration, please refer to the attached file (Test Setup Photo).

3.1.4 TEST RESULTS

AVERAGE CONDUCTED OUTPUT POWER (dBm)

LTE Band 7

| Band/BW | Modulation | RB Size | RB Offset | Low CH 20775 | Mid CH 21100 | High CH 21425 | MPR |
|---------|------------|---------|-----------|-------------------------|-----------------------|-------------------------|-----|
| | | | | Frequency 2502.5 MHz | Frequency 2535 MHz | Frequency 2567.5 MHz | |
| 7/5 | QPSK | 1 | 0 | 23.19 | 23.15 | 22.98 | 0 |
| | | 1 | 12 | 23.19 | 23.11 | 22.98 | 0 |
| | | 1 | 24 | 23.25 | 23.20 | 23.08 | 0 |
| | | 12 | 0 | 22.11 | 22.08 | 21.89 | 1 |
| | | 12 | 6 | 22.08 | 22.13 | 21.90 | 1 |
| | | 12 | 13 | 22.22 | 22.19 | 22.04 | 1 |
| | | 25 | 0 | 22.06 | 22.08 | 21.86 | 1 |
| | 16QAM | 1 | 0 | 22.41 | 22.41 | 22.25 | 1 |
| | | 1 | 12 | 22.27 | 22.31 | 22.09 | 1 |
| | | 1 | 24 | 22.42 | 22.34 | 22.21 | 1 |
| | | 12 | 0 | 21.24 | 21.24 | 21.03 | 2 |
| | | 12 | 6 | 21.24 | 21.26 | 21.03 | 2 |
| | | 12 | 13 | 21.23 | 21.23 | 21.07 | 2 |
| | | 25 | 0 | 21.28 | 21.25 | 21.08 | 2 |



Test Report No.: W7L-P22030013RF03

| Band/BW | Modulation | RB Size | RB Offset | Low CH 20800 | Mid CH 21100 | High CH 21400 | MPR |
|---------|------------|---------|-----------|--------------------|--------------------|--------------------|-----|
| | | | | Frequency 2505 MHz | Frequency 2535 MHz | Frequency 2565 MHz | |
| 7/ 10 | QPSK | 1 | 0 | 23.16 | 23.18 | 22.98 | 0 |
| | | 1 | 24 | 23.19 | 23.11 | 22.99 | 0 |
| | | 1 | 49 | 23.22 | 23.24 | 23.04 | 0 |
| | | 25 | 0 | 22.12 | 22.07 | 21.92 | 1 |
| | | 25 | 12 | 22.14 | 22.07 | 21.90 | 1 |
| | | 25 | 25 | 22.20 | 22.16 | 22.03 | 1 |
| | | 50 | 0 | 22.11 | 22.08 | 21.83 | 1 |
| | 16QAM | 1 | 0 | 22.41 | 22.38 | 22.21 | 1 |
| | | 1 | 24 | 22.32 | 22.27 | 22.12 | 1 |
| | | 1 | 49 | 22.42 | 22.35 | 22.18 | 1 |
| | | 25 | 0 | 21.26 | 21.22 | 21.09 | 2 |
| | | 25 | 12 | 21.28 | 21.20 | 21.08 | 2 |
| | | 25 | 25 | 21.22 | 21.24 | 21.04 | 2 |
| | | 50 | 0 | 21.32 | 21.24 | 21.12 | 2 |



Test Report No.: W7L-P22030013RF03

| Band/BW | Modulation | RB Size | RB Offset | Low CH 20825 | Mid CH 21100 | High CH 21375 | MPR |
|---------|------------|---------|-----------|----------------------|--------------------|----------------------|-----|
| | | | | Frequency 2507.5 MHz | Frequency 2535 MHz | Frequency 2562.5 MHz | |
| 7/ 15 | QPSK | 1 | 0 | 23.23 | 23.18 | 22.95 | 0 |
| | | 1 | 37 | 23.17 | 23.16 | 22.94 | 0 |
| | | 1 | 74 | 23.28 | 23.27 | 23.05 | 0 |
| | | 36 | 0 | 22.09 | 22.08 | 21.93 | 1 |
| | | 36 | 19 | 22.15 | 22.12 | 21.90 | 1 |
| | | 36 | 39 | 22.18 | 22.17 | 22.03 | 1 |
| | | 75 | 0 | 22.11 | 22.06 | 21.88 | 1 |
| | 16QAM | 1 | 0 | 22.45 | 22.45 | 22.21 | 1 |
| | | 1 | 37 | 22.31 | 22.28 | 22.12 | 1 |
| | | 1 | 74 | 22.38 | 22.40 | 22.20 | 1 |
| | | 36 | 0 | 21.30 | 21.22 | 21.10 | 2 |
| | | 36 | 19 | 21.22 | 21.24 | 21.04 | 2 |
| | | 36 | 39 | 21.27 | 21.22 | 21.07 | 2 |
| | | 75 | 0 | 21.33 | 21.27 | 21.05 | 2 |



Test Report No.: W7L-P22030013RF03

| Band/BW | Modulation | RB Size | RB Offset | Low CH 20850 | Mid CH 21100 | High CH 21350 | MPR |
|---------|------------|---------|-----------|--------------------|--------------------|--------------------|-----|
| | | | | Frequency 2510 MHz | Frequency 2535 MHz | Frequency 2560 MHz | |
| 7/ 20 | QPSK | 1 | 0 | 23.22 | 23.24 | 23.03 | 0 |
| | | 1 | 50 | 23.19 | 23.21 | 23.00 | 0 |
| | | 1 | 99 | 22.38 | 23.30 | 23.09 | 0 |
| | | 50 | 0 | 22.13 | 22.15 | 21.94 | 1 |
| | | 50 | 25 | 22.14 | 22.16 | 21.95 | 1 |
| | | 50 | 50 | 22.24 | 22.26 | 22.05 | 1 |
| | | 100 | 0 | 22.10 | 22.12 | 21.91 | 1 |
| | 16QAM | 1 | 0 | 22.46 | 22.48 | 22.27 | 1 |
| | | 1 | 50 | 22.33 | 22.35 | 22.14 | 1 |
| | | 1 | 99 | 22.42 | 22.44 | 22.23 | 1 |
| | | 50 | 0 | 21.30 | 21.32 | 21.11 | 2 |
| | | 50 | 25 | 21.28 | 21.30 | 21.09 | 2 |
| | | 50 | 50 | 21.28 | 21.30 | 21.09 | 2 |
| | | 100 | 0 | 21.32 | 21.34 | 21.13 | 2 |



Test Report No.: W7L-P22030013RF03

EIRP

LTE BAND 7

CHANNEL BANDWIDTH: 5MHz QPSK

| Channel | Frequency (MHz) | Conducted Power (dBm) | G _T -L _c (dB) | EIRP (dBm) | EIRP (mW) | Limit (W) |
|---------|-----------------|-----------------------|-------------------------------------|------------|---------------|-----------|
| 20775 | 2502.5 | 23.25 | 2 | 25.25 | 334.97 | 2 |
| 21100 | 2535.0 | 23.2 | 2 | 25.2 | 331.13 | 2 |
| 21425 | 2567.5 | 23.08 | 2 | 25.08 | 322.11 | 2 |

CHANNEL BANDWIDTH: 5MHz 16QAM

| Channel | Frequency (MHz) | Conducted Power (dBm) | G _T -L _c (dB) | EIRP (dBm) | EIRP (mW) | Limit (W) |
|---------|-----------------|-----------------------|-------------------------------------|------------|-----------|-----------|
| 20775 | 2502.5 | 22.42 | 2 | 24.42 | 276.69 | 2 |
| 21100 | 2535.0 | 22.41 | 2 | 24.41 | 276.06 | 2 |
| 21425 | 2567.5 | 22.25 | 2 | 24.25 | 266.07 | 2 |

CHANNEL BANDWIDTH: 10MHz QPSK

| Channel | Frequency (MHz) | Conducted Power (dBm) | G _T -L _c (dB) | EIRP (dBm) | EIRP (mW) | Limit (W) |
|---------|-----------------|-----------------------|-------------------------------------|------------|--------------|-----------|
| 20800 | 2505.0 | 23.22 | 2 | 25.22 | 332.66 | 2 |
| 21100 | 2535.0 | 23.24 | 2 | 25.24 | 334.2 | 2 |
| 21400 | 2565.0 | 23.04 | 2 | 25.04 | 319.15 | 2 |

CHANNEL BANDWIDTH: 10MHz 16QAM

| Channel | Frequency (MHz) | Conducted Power (dBm) | G _T -L _c (dB) | EIRP (dBm) | EIRP (mW) | Limit (W) |
|---------|-----------------|-----------------------|-------------------------------------|------------|-----------|-----------|
| 20800 | 2505.0 | 22.42 | 2 | 24.42 | 276.69 | 2 |
| 21100 | 2535.0 | 22.38 | 2 | 24.38 | 274.16 | 2 |
| 21400 | 2565.0 | 22.21 | 2 | 24.21 | 263.63 | 2 |

CHANNEL BANDWIDTH: 15MHz QPSK

| Channel | Frequency (MHz) | Conducted Power (dBm) | G _T -L _c (dB) | EIRP (dBm) | EIRP (mW) | Limit (W) |
|---------|-----------------|-----------------------|-------------------------------------|------------|---------------|-----------|
| 20825 | 2507.5 | 23.28 | 2 | 25.28 | 337.29 | 2 |
| 21100 | 2535.0 | 23.27 | 2 | 25.27 | 336.51 | 2 |
| 21375 | 2562.5 | 23.05 | 2 | 25.05 | 319.89 | 2 |

CHANNEL BANDWIDTH: 15MHz 16QAM

| Channel | Frequency (MHz) | Conducted Power (dBm) | G _T -L _c (dB) | EIRP (dBm) | EIRP (mW) | Limit (W) |
|---------|-----------------|-----------------------|-------------------------------------|------------|-----------|-----------|
| 20825 | 2507.5 | 22.45 | 2 | 24.45 | 278.61 | 2 |
| 21100 | 2535.0 | 22.45 | 2 | 24.45 | 278.61 | 2 |
| 21375 | 2562.5 | 22.21 | 2 | 24.21 | 263.63 | 2 |

CHANNEL BANDWIDTH: 20MHz QPSK

| Channel | Frequency (MHz) | Conducted Power (dBm) | G _T -L _c (dB) | EIRP (dBm) | EIRP (mW) | Limit (W) |
|---------|-----------------|-----------------------|-------------------------------------|------------|---------------|-----------|
| 20850 | 2510.0 | 23.22 | 2 | 25.22 | 332.66 | 2 |
| 21100 | 2535.0 | 23.3 | 2 | 25.3 | 338.84 | 2 |
| 21350 | 2560.0 | 23.09 | 2 | 25.09 | 322.85 | 2 |

CHANNEL BANDWIDTH: 20MHz 16QAM

| Channel | Frequency (MHz) | Conducted Power (dBm) | G _T -L _c (dB) | EIRP (dBm) | EIRP (mW) | Limit (W) |
|---------|-----------------|-----------------------|-------------------------------------|------------|-----------|-----------|
| 20850 | 2510.0 | 22.46 | 2 | 24.46 | 279.25 | 2 |
| 21100 | 2535.0 | 22.48 | 2 | 24.48 | 280.54 | 2 |
| 21350 | 2560.0 | 22.27 | 2 | 24.27 | 267.3 | 2 |

3.2 FREQUENCY STABILITY MEASUREMENT

3.2.1 LIMITS OF FREQUENCY STABILITY MEASUREMENT

The frequency stability shall be sufficient to ensure that the fundamental emissions stay within the authorized bands of operation.

3.2.2 TEST PROCEDURE

- a. Device is placed at the oven room. The oven room could control the temperatures and humidity. Power warm up is at least 15 min and power applied should perform before recording frequency error.
- b. EUT is connected the external power supply to control the DC input power. The test voltage range is from minimum to maximum working voltage. Each step shall be record the frequency error rate.
- c. The temperature range step is 10 degrees in this test items. All temperature levels shall be hold the $\pm 0.5^{\circ}\text{C}$ during the measurement testing. The each temperature step shall be at least 0.5 hours, consider the EUT could be test under the stability condition.

NOTE: The frequency error was recorded frequency error from the communication simulator.

3.2.3 TEST SETUP

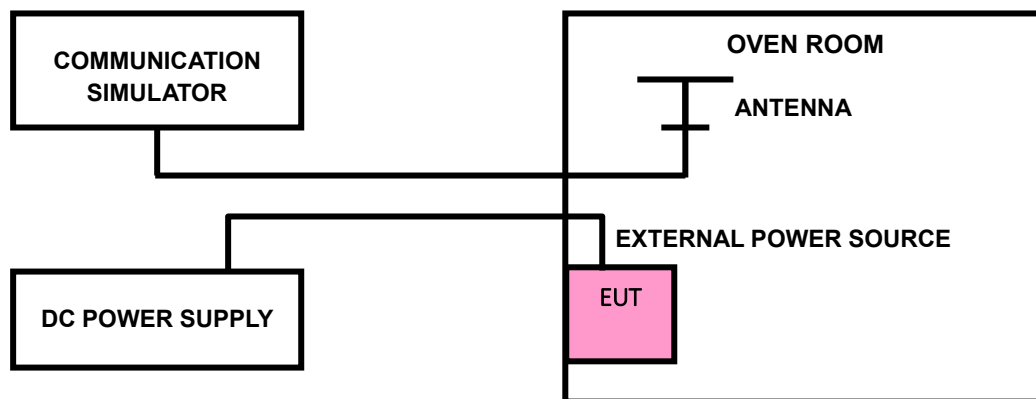



Test Report No.: W7L-P22030013RF03

3.2.4 TEST RESULTS

Please Refer to Appendix Of this test report.

3.3 OCCUPIED BANDWIDTH MEASUREMENT

3.3.1 LIMITS OF OCCUPIED BANDWIDTH MEASUREMENT

The width of a frequency band such that, below the lower and above the upper frequency limits, the mean powers emitted are each equal to a specified percentage 0.5 % of the total mean power of a given emission.

3.3.2 TEST SETUP

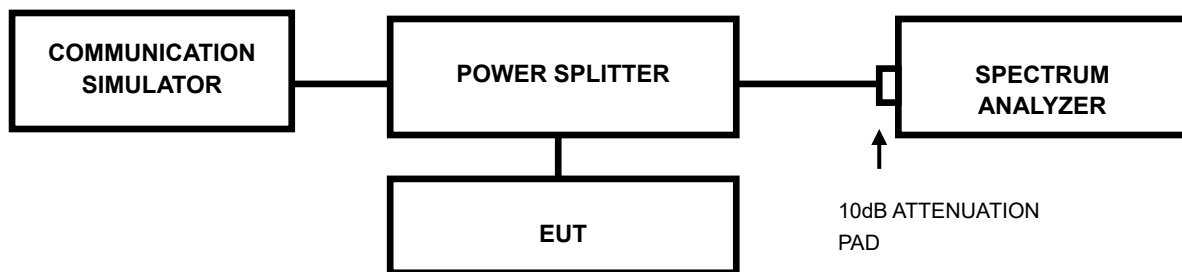

3.3.3 TEST PROCEDURES

- The conducted occupied bandwidth used the power splitter via EUT RF power connector between simulation base station and spectrum analyzer.
- Use OBW measurement function of Spectrum analyzer to measure 99 % occupied bandwidth.



Test Report No.: W7L-P22030013RF03

3.3.4 TEST RESULTS

Please Refer to Appendix Of this test report.

3.4 BAND EDGE MEASUREMENT

3.4.1 LIMITS OF BAND EDGE MEASUREMENT

According to FCC 27.53(m)(4) specified that For mobile digital stations, the attenuation factor shall be not less than $40 + 10 \log (P)$ dB on all frequencies between the channel edge and 5 megahertz from the channel edge, $43 + 10 \log (P)$ dB on all frequencies between 5 megahertz and X megahertz from the channel edge, and $55 + 10 \log (P)$ dB on all frequencies more than X megahertz from the channel edge, where X is the greater of 6 megahertz or the actual emission bandwidth as defined in paragraph (m)(6) of this section. In addition, the attenuation factor shall not be less that $43 + 10 \log (P)$ dB on all frequencies between 2490.5 MHz and 2496 MHz and $55 + 10 \log (P)$ dB at or below 2490.5 MHz. Mobile Satellite Service licensees operating on frequencies below 2495 MHz may also submit a documented interference complaint against BRS licensees operating on channel BRS Channel 1 on the same terms and conditions as adjacent channel BRS or EBS licensees. For mobile digital stations, in the 1 megahertz bands immediately outside and adjacent to the frequency block a resolution bandwidth of at least two percent may be employed.

3.4.2 TEST SETUP

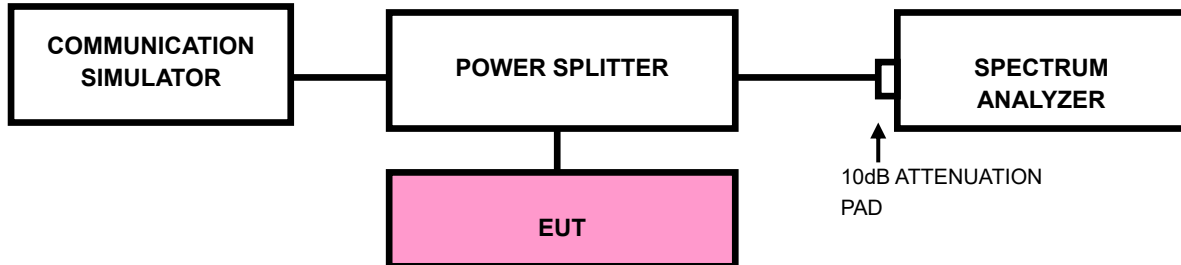

3.4.3 TEST PROCEDURES

- a. All measurements were done at low and high operational frequency range.
- b. The center frequency of spectrum is the band edge frequency and span is 1~5 MHz.
RBW of the spectrum is 10kHz and VBW of the spectrum is 30kHz (LTE bandwidth for (1.4M/3M/5M/10M/15M/20M)1RB/0RB&1RB/MAXRB).
- c. The center frequency of spectrum is the band edge frequency and span is 10MHz.
RBW of the spectrum is 100kHz and VBW of the spectrum is 300kHz (WCDMA).



**BUREAU
VERITAS**

Test Report No.: W7L-P22030013RF03

- d. The center frequency of spectrum is the band edge frequency and span is 1~5 MHz. RBW of the spectrum is $\geq 1\% \cdot \text{EBW}$ kHz and VBW of the spectrum is $3 \cdot \text{RBW}$ kHz. (LTE bandwidth 1.4M/3M/5M/10M/15M/20MHz).

- e. Record the max trace plot into the test report.



Test Report No.: W7L-P22030013RF03

3.4.4 TEST RESULTS

Please Refer to Appendix Of this test report.

3.5 CONDUCTED SPURIOUS EMISSIONS

3.5.1 LIMITS OF CONDUCTED SPURIOUS EMISSIONS MEASUREMENT

For: LTE Band7

The power of any emission outside a licensee's frequency block shall be attenuated below the transmitter power (P) by at least $55 + 10 \log_{10}(P)$ dB. The limit of emission is equal to -25dBm.

3.5.2 TEST PROCEDURE

- a. The EUT makes a phone call to the communication simulator. All measurements were done at low, middle and high operational frequency range.
- b. Measuring frequency range is from 9kHz up to a frequency including its 10th harmonic. 10dB attenuation pad is connected with spectrum. RBW=1MHz and VBW=3MHz is used for conducted emission measurement.

3.5.3 TEST SETUP

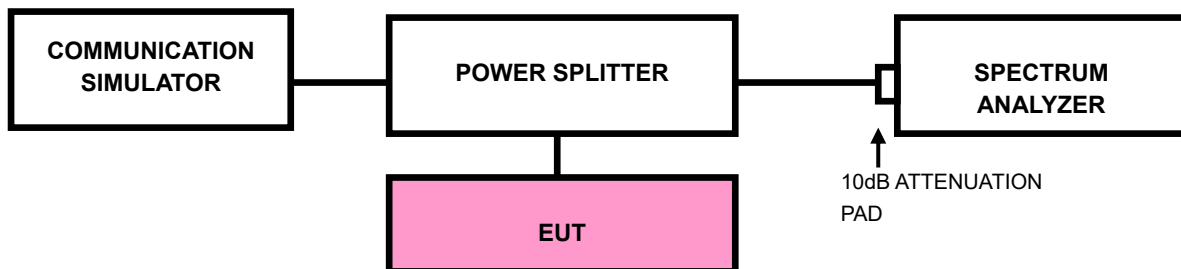



**BUREAU
VERITAS**

Test Report No.: W7L-P22030013RF03

3.5.4 TEST RESULTS

NOTE : The 9K~30MHz amplitude of spurious emissions attenuated more than 20 dB below the permissible value is not required in the report.

Please Refer to Appendix Of this test report.



Test Report No.: W7L-P22030013RF03

3.6 RADIATED EMISSION MEASUREMENT

3.6.1 LIMITS OF RADIATED EMISSION MEASUREMENT

For: LTE Band7

The power of any emission outside a licensee's frequency block shall be attenuated below the transmitter power (P) by at least $55 + 10 \log_{10}(P)$ dB. The limit of emission is equal to -25dBm.

3.6.2 TEST PROCEDURES

- a. Substitution method is used for E.I.R.P measurement. In the semi-anechoic chamber, EUT placed on the 0.8m height of Turn Table, rotated the table around 360 degrees to search the maximum radiation power and receiver antenna shall be rotated vertical and horizontal polarization and moved height from 1m to 4m to find the maximum polar radiated power. The "Read Value" is the spectrum reading the maximum power value.
- b. The substitution horn antenna is substituted for EUT at the same position and signals generator export the CW signal to the substitution antenna via a TX cable. Rotated the Turn Table and moved receiving antenna to find the maximum radiation power. Adjust output power level of S.G to get a Value of spectrum reading equal to "Read Value " of step a. Record the power level of S.G.
- c. EIRP = Output power level of S.G – TX cable loss + Antenna gain of substitution horn.
- d. E.R.P power can be calculated form E.I.R.P power by subtracting the gain of dipole, $E.R.P \text{ power} = E.I.P.R \text{ power} - 2.15\text{dBi}$.

NOTE: The resolution bandwidth of spectrum analyzer is 1 MHz and the video bandwidth is 3 MHz.

3.6.3 DEVIATION FROM TEST STANDARD

No deviation

3.6.4 TEST SETUP

< Frequency Range below 30MHz >

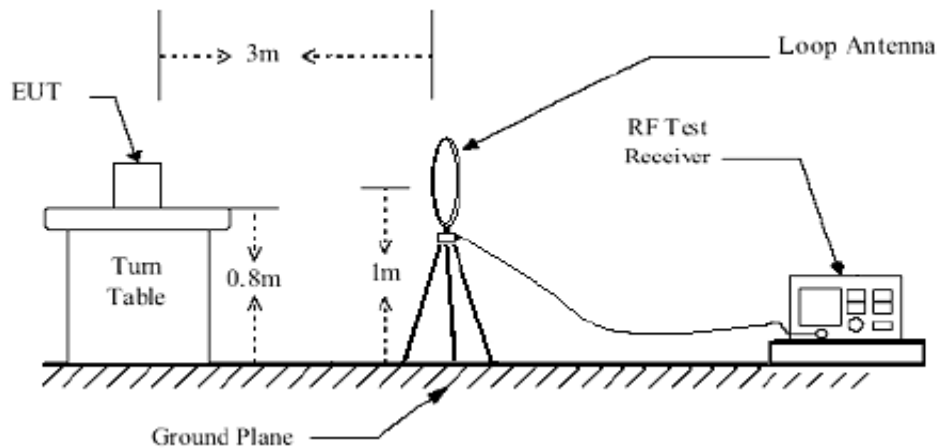

< Frequency Range 30MHz~1GHz >

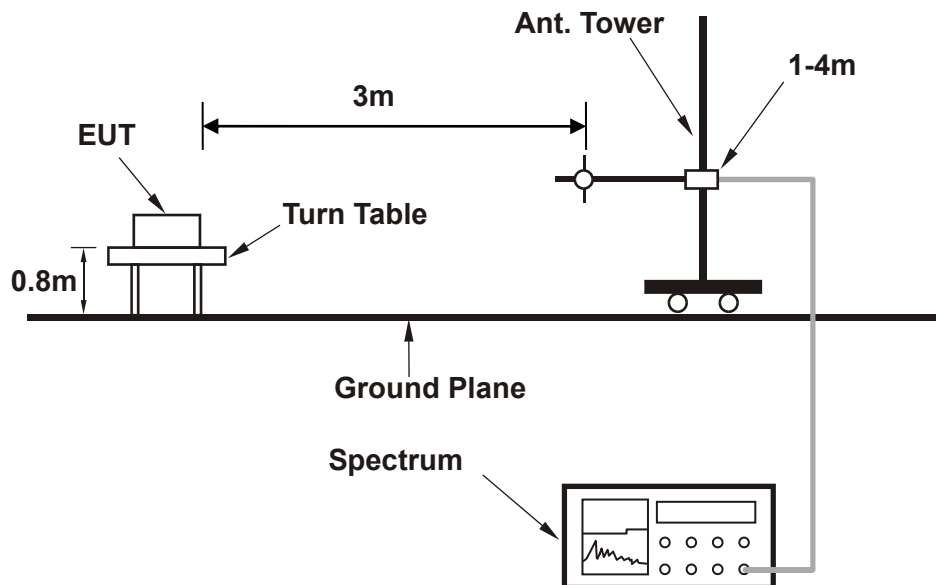

<Frequency Range above 1GHz>

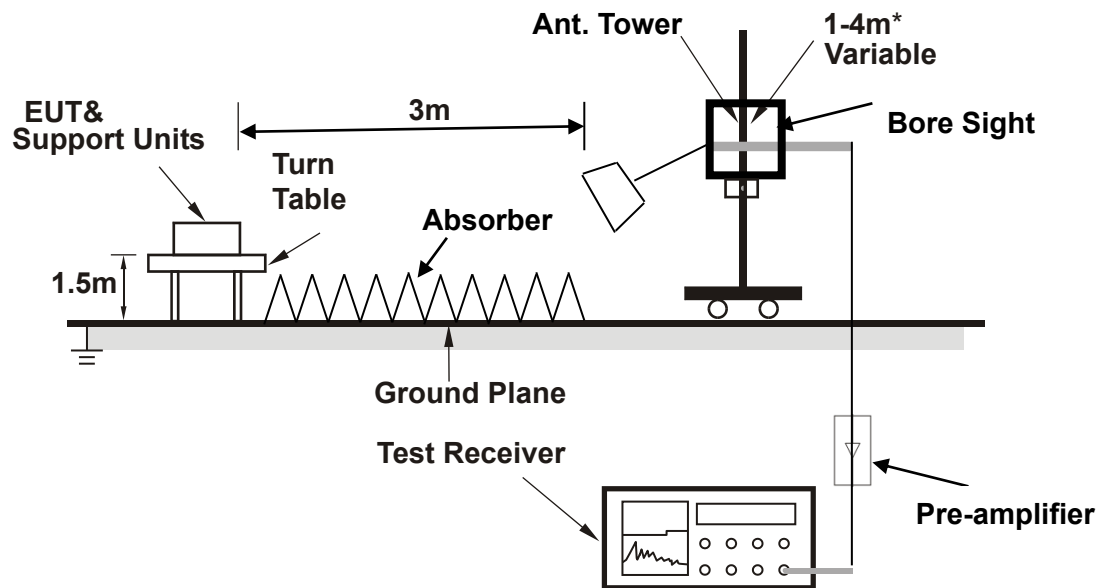

Note: Above 1G is a directional antenna depends on the EUT height and the antenna 3dB beamwidth both, refer to section 7.3 of CISPR 16-2-3.

For the actual test configuration, please refer to the attached file (Test Setup Photo).



Test Report No.: W7L-P22030013RF03

3.6.5 TEST RESULTS

NOTE : The 9K~30MHz amplitude of spurious emissions attenuated more than 20 dB below the permissible value is not required in the report.

BELOW 1GHz WORST-CASE DATA

30 MHz – 1GHz data:

LTE Band 7

CHANNEL BANDWIDTH: 5MHz / QPSK

| | | | |
|----------------------------------------------------------------|------------------|-----------------|---------------|
| MODE | TX channel 21425 | FREQUENCY RANGE | Below 1000MHz |
| ENVIRONMENTAL CONDITIONS | 23deg. C, 70%RH | INPUT POWER | AC 120V/60HZ |
| TESTED BY | Jace Hu | | |
| ANTENNA POLARITY & TEST DISTANCE: HORIZONTAL AT 3 M | | | |

| | Freq | Level | Read Level | Limit Line | Over Limit | Factor | Remark | Pol/Phase |
|---|-----------|--------|------------|------------|------------|--------|--------|------------|
| | MHz | dBm/m | dBm | dBm/m | dB | dB/m | | |
| 1 | PP 84.320 | -56.11 | -47.86 | -25.00 | -31.11 | -8.25 | Peak | Horizontal |
| 2 | 166.770 | -73.48 | -55.25 | -25.00 | -48.48 | -18.23 | Peak | Horizontal |
| 3 | 207.510 | -70.49 | -53.40 | -25.00 | -45.49 | -17.09 | Peak | Horizontal |
| 4 | 312.270 | -72.06 | -58.66 | -25.00 | -47.06 | -13.40 | Peak | Horizontal |
| 5 | 422.850 | -71.76 | -61.32 | -25.00 | -46.76 | -10.44 | Peak | Horizontal |
| 6 | 650.800 | -67.54 | -60.54 | -25.00 | -42.54 | -7.00 | Peak | Horizontal |

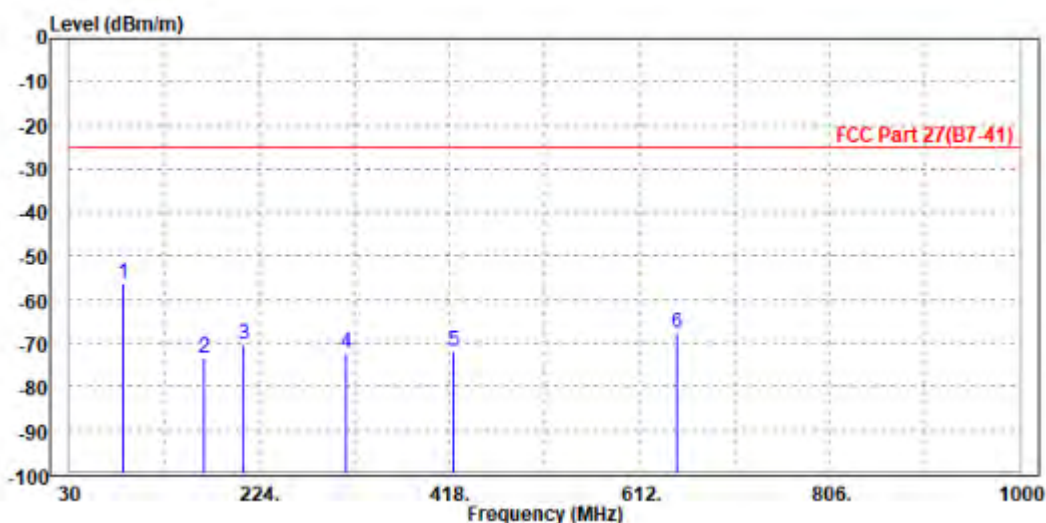



Test Report No.: W7L-P22030013RF03

| | | | |
|--------------------------------------------------------------|------------------|-----------------|---------------|
| MODE | TX channel 21425 | FREQUENCY RANGE | Below 1000MHz |
| ENVIRONMENTAL CONDITIONS | 23deg. C, 70%RH | INPUT POWER | AC 120V/60HZ |
| TESTED BY | Jace Hu | | |
| ANTENNA POLARITY & TEST DISTANCE: VERTICAL AT 3 M | | | |

| | Freq | Level | Read Level | Limit Line | Over Limit | Factor | Remark | Pol/Phase |
|------|---------|--------|------------|------------|------------|--------|--------|-----------|
| | MHz | dBm/m | dBm | dBm/m | dB | dB/m | | |
| 1 PP | 45.520 | -35.04 | -31.70 | -25.00 | -10.04 | -3.34 | Peak | Vertical |
| 2 | 85.290 | -57.37 | -46.97 | -25.00 | -32.37 | -10.40 | Peak | Vertical |
| 3 | 125.060 | -66.59 | -54.38 | -25.00 | -41.59 | -12.21 | Peak | Vertical |
| 4 | 203.630 | -66.28 | -55.58 | -25.00 | -41.28 | -10.70 | Peak | Vertical |
| 5 | 297.720 | -73.99 | -62.69 | -25.00 | -48.99 | -11.30 | Peak | Vertical |
| 6 | 754.590 | -67.74 | -62.04 | -25.00 | -42.74 | -5.70 | Peak | Vertical |

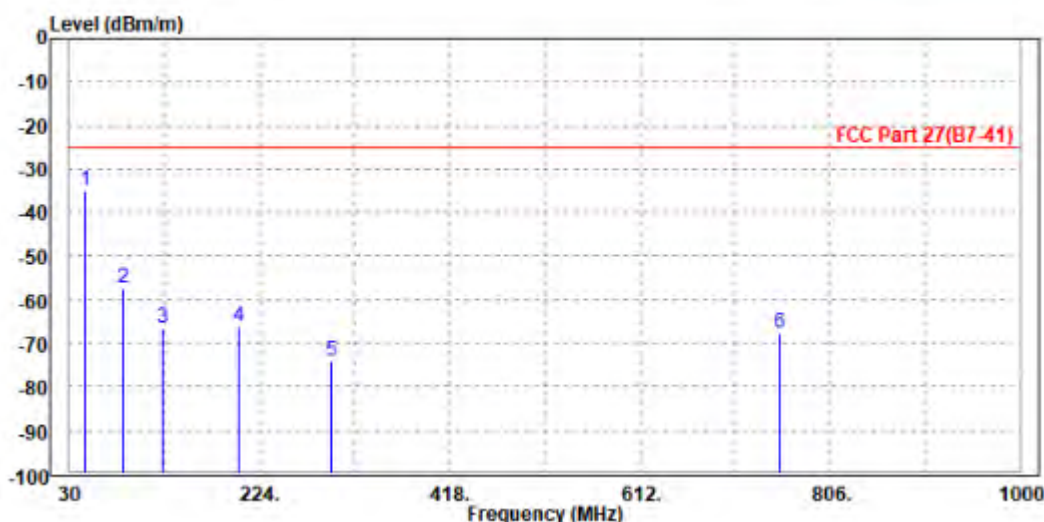



BUREAU VERITAS

Test Report No.: W7L-P22030013RF03

ABOVE 1GHz

Note: For higher frequency, the emission is too low to be detected.

LTE Band 7

CHANNEL BANDWIDTH: 5MHz / QPSK

| | | | |
|-----------------------------------------------------|------------------|-----------------|---------------|
| MODE | TX channel 21100 | FREQUENCY RANGE | Above 1000MHz |
| ENVIRONMENTAL CONDITIONS | 23deg. C, 70%RH | INPUT POWER | AC 120V/60HZ |
| TESTED BY | Jace Hu | | |
| ANTENNA POLARITY & TEST DISTANCE: HORIZONTAL AT 3 M | | | |

| | Freq | Level | Read Level | Limit Line | Over Limit | Factor | Remark | Pol/Phase |
|---|-------------|--------|------------|------------|------------|--------|--------|------------|
| | MHz | dBm/m | dBm | dBm/m | dB | dB/m | | |
| 1 | PP 5082.000 | -49.24 | -58.01 | -25.00 | -24.24 | 8.77 | Peak | Horizontal |
| 2 | 7605.000 | -49.83 | -61.23 | -25.00 | -24.83 | 11.40 | Peak | Horizontal |

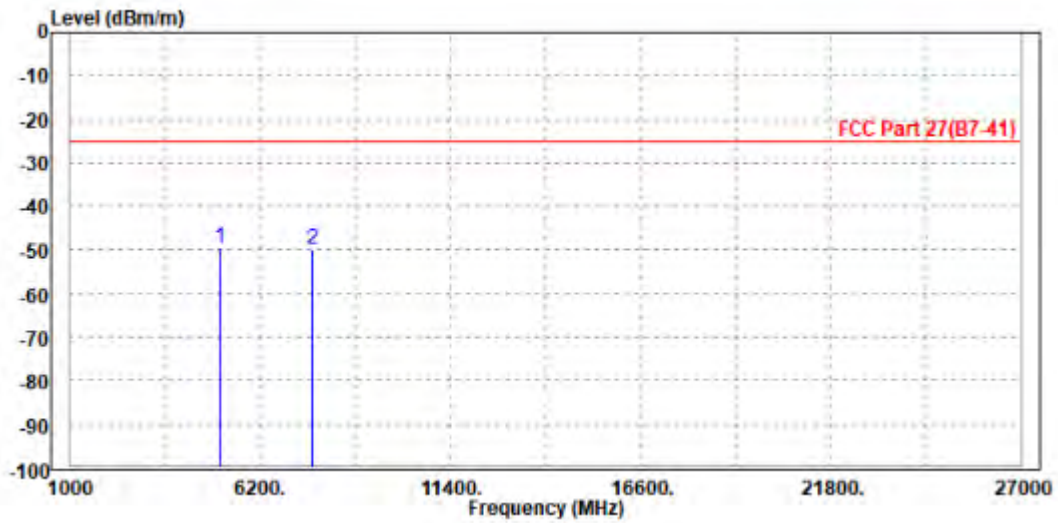



Test Report No.: W7L-P22030013RF03

| | | | |
|--------------------------------------------------------------|------------------|------------------------|---------------|
| MODE | TX channel 21100 | FREQUENCY RANGE | Above 1000MHz |
| ENVIRONMENTAL CONDITIONS | 23deg. C, 70%RH | INPUT POWER | AC 120V/60HZ |
| TESTED BY | Jace Hu | | |
| ANTENNA POLARITY & TEST DISTANCE: VERTICAL AT 3 M | | | |

| | Freq | Level | Read Level | Limit Line | Over Limit | Factor | Remark | Pol/Phase |
|---|-------------|--------|------------|------------|------------|--------|--------|-----------|
| | MHz | dBm/m | dBm | dBm/m | dB | dB/m | | |
| 1 | PP 5070.000 | -48.58 | -58.45 | -25.00 | -23.58 | 9.87 | Peak | Vertical |
| 2 | 7604.000 | -49.90 | -62.68 | -25.00 | -24.90 | 12.78 | Peak | Vertical |

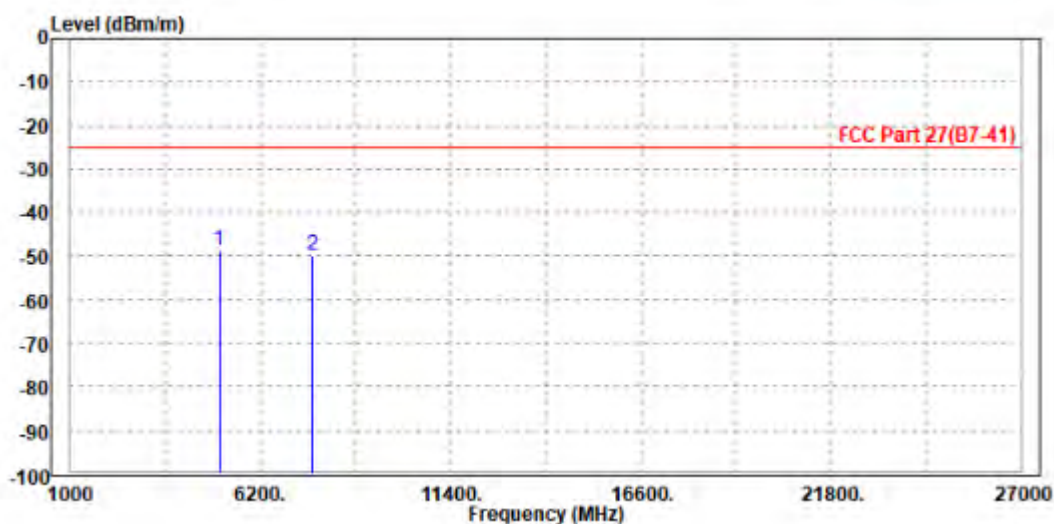



Test Report No.: W7L-P22030013RF03

CHANNEL BANDWIDTH: 10MHz / QPSK

| | | | |
|----------------------------------------------------------------|------------------|-----------------|---------------|
| MODE | TX channel 21100 | FREQUENCY RANGE | Above 1000MHz |
| ENVIRONMENTAL CONDITIONS | 23deg. C, 70%RH | INPUT POWER | AC 120V/60HZ |
| TESTED BY | Jace Hu | | |
| ANTENNA POLARITY & TEST DISTANCE: HORIZONTAL AT 3 M | | | |

| | Freq | Level | Read Level | Limit Line | Over Limit | Factor | Remark | Pol/Phase |
|---|-------------|--------|------------|------------|------------|--------|--------|------------|
| | MHz | dBm/m | dBm | dBm/m | dB | dB/m | | |
| 1 | PP 5082.000 | -47.58 | -56.35 | -25.00 | -22.58 | 8.77 | Peak | Horizontal |
| 2 | 7605.000 | -50.06 | -61.46 | -25.00 | -25.06 | 11.40 | Peak | Horizontal |

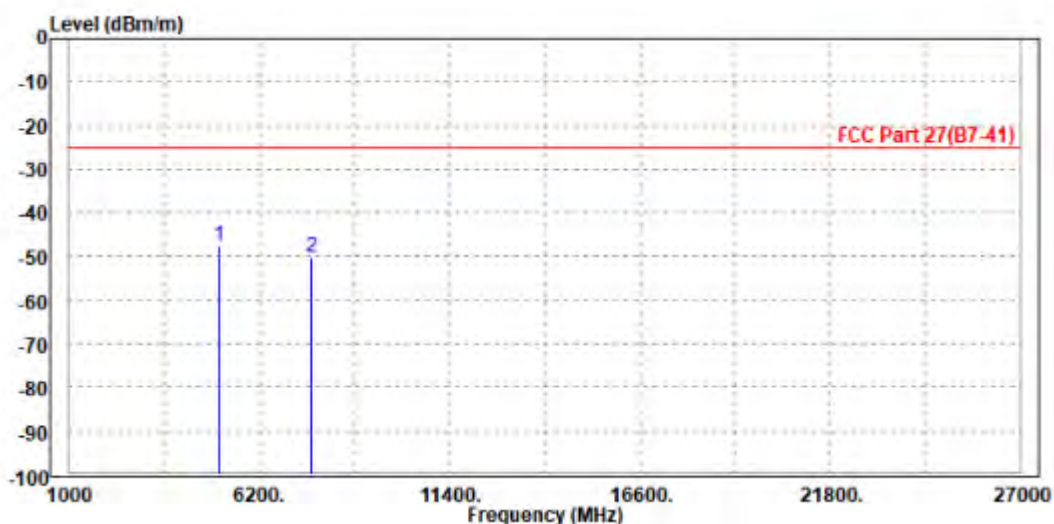



Test Report No.: W7L-P22030013RF03

| | | | |
|--------------------------------------------------------------|------------------|------------------------|---------------|
| MODE | TX channel 21100 | FREQUENCY RANGE | Above 1000MHz |
| ENVIRONMENTAL CONDITIONS | 23deg. C, 70%RH | INPUT POWER | AC 120V/60HZ |
| TESTED BY | Jace Hu | | |
| ANTENNA POLARITY & TEST DISTANCE: VERTICAL AT 3 M | | | |

| | Freq | Level | Read Level | Limit Line | Over Limit | Factor | Remark | Pol/Phase |
|---|-------------|--------|------------|------------|------------|--------|--------|-----------|
| | MHz | dBm/m | dBm | dBm/m | dB | dB/m | | |
| 1 | PP 5070.000 | -48.42 | -58.29 | -25.00 | -23.42 | 9.87 | Peak | Vertical |
| 2 | 7604.000 | -49.12 | -61.90 | -25.00 | -24.12 | 12.78 | Peak | Vertical |

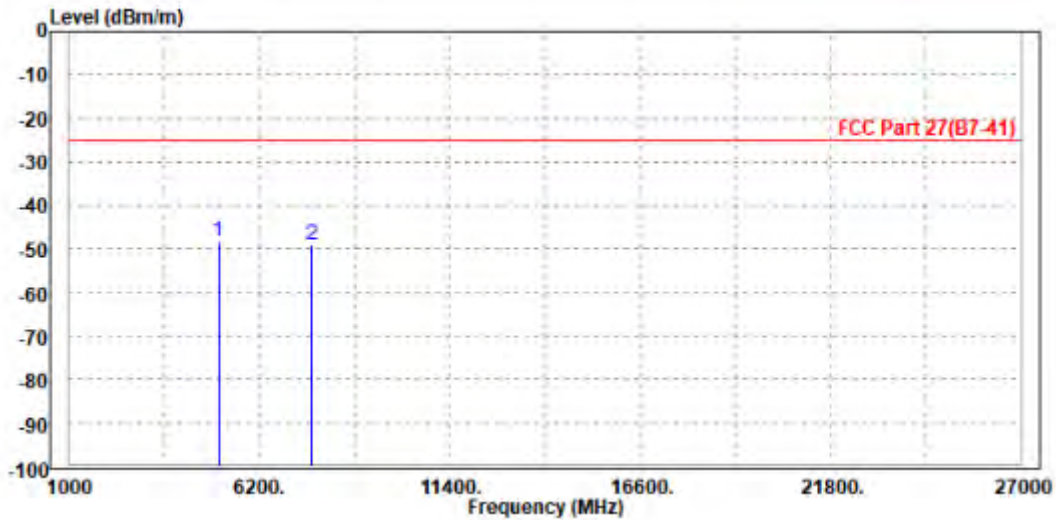



BUREAU VERITAS

Test Report No.: W7L-P22030013RF03

CHANNEL BANDWIDTH: 15MHz / QPSK

CH20825

| | | | |
|----------------------------------------------------------------|------------------|-----------------|---------------|
| MODE | TX channel 20825 | FREQUENCY RANGE | Above 1000MHz |
| ENVIRONMENTAL CONDITIONS | 23deg. C, 70%RH | INPUT POWER | AC 120V/60HZ |
| TESTED BY | Jace Hu | | |
| ANTENNA POLARITY & TEST DISTANCE: HORIZONTAL AT 3 M | | | |

| | Freq | Level | Read Level | Limit Line | Over Limit | Factor | Remark | Pol/Phase |
|---|-------------|--------|------------|------------|------------|--------|--------|------------|
| | MHz | dBm/m | dBm | dBm/m | dB | dB/m | | |
| 1 | PP 5004.000 | -49.65 | -58.19 | -25.00 | -24.65 | 8.54 | Peak | Horizontal |
| 2 | 7522.500 | -50.01 | -61.38 | -25.00 | -25.01 | 11.37 | Peak | Horizontal |

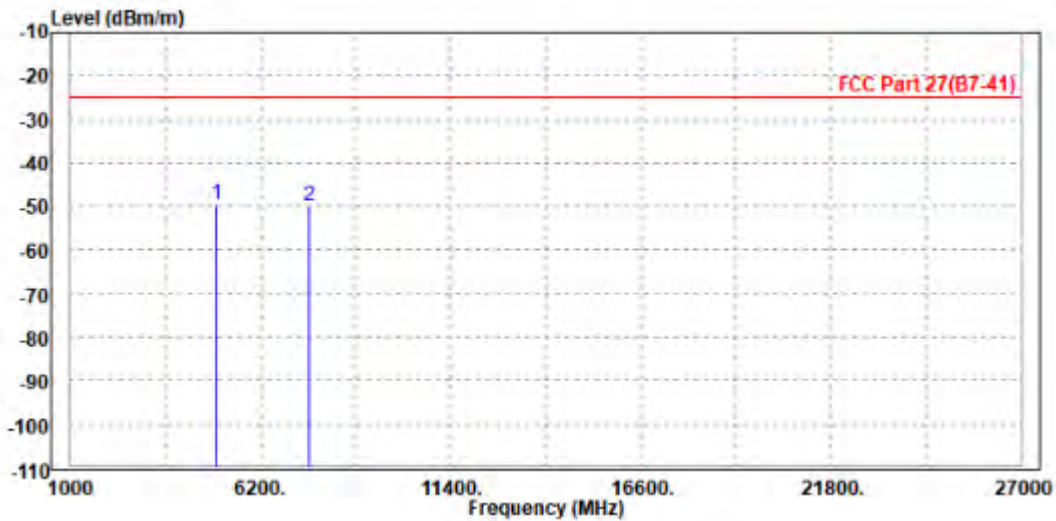



Test Report No.: W7L-P22030013RF03

| | | | |
|--------------------------------------------------------------|------------------|------------------------|---------------|
| MODE | TX channel 20825 | FREQUENCY RANGE | Above 1000MHz |
| ENVIRONMENTAL CONDITIONS | 23deg. C, 70%RH | INPUT POWER | AC 120V/60HZ |
| TESTED BY | Jace Hu | | |
| ANTENNA POLARITY & TEST DISTANCE: VERTICAL AT 3 M | | | |

| | Freq | Level | Read Level | Limit Line | Over Limit | Factor | Remark | Pol/Phase |
|---|-------------|--------|------------|------------|------------|--------|--------|-----------|
| | MHz | dBm/m | dBm | dBm/m | dB | dB/m | | |
| 1 | PP 5015.000 | -48.21 | -58.10 | -25.00 | -23.21 | 9.89 | Peak | Vertical |
| 2 | 7526.000 | -48.25 | -61.00 | -25.00 | -23.25 | 12.75 | Peak | Vertical |

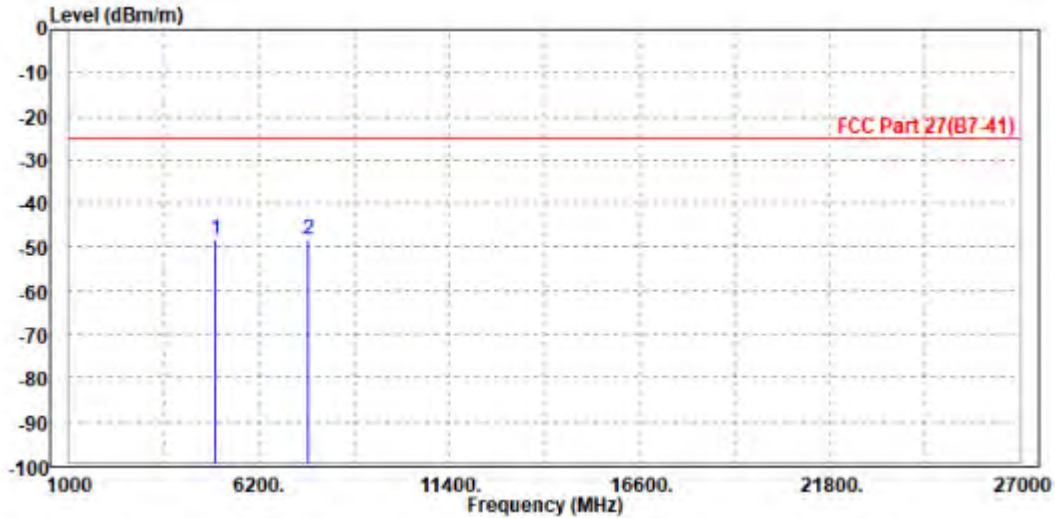



**BUREAU
VERITAS**

Test Report No.: W7L-P22030013RF03

CH21100

| | | | |
|----------------------------------------------------------------|------------------|------------------------|---------------|
| MODE | TX channel 21100 | FREQUENCY RANGE | Above 1000MHz |
| ENVIRONMENTAL CONDITIONS | 23deg. C, 70%RH | INPUT POWER | AC 120V/60HZ |
| TESTED BY | Jace Hu | | |
| ANTENNA POLARITY & TEST DISTANCE: HORIZONTAL AT 3 M | | | |

| | Freq | Level | Read Level | Limit Line | Over Limit | Factor | Remark | Pol/Phase |
|---|-------------|--------|------------|------------|------------|--------|--------|------------|
| | MHz | dBm/m | dBm | dBm/m | dB | dB/m | | |
| 1 | PP 5082.000 | -47.58 | -56.35 | -25.00 | -22.58 | 8.77 | Peak | Horizontal |
| 2 | 7605.000 | -50.06 | -61.46 | -25.00 | -25.06 | 11.40 | Peak | Horizontal |

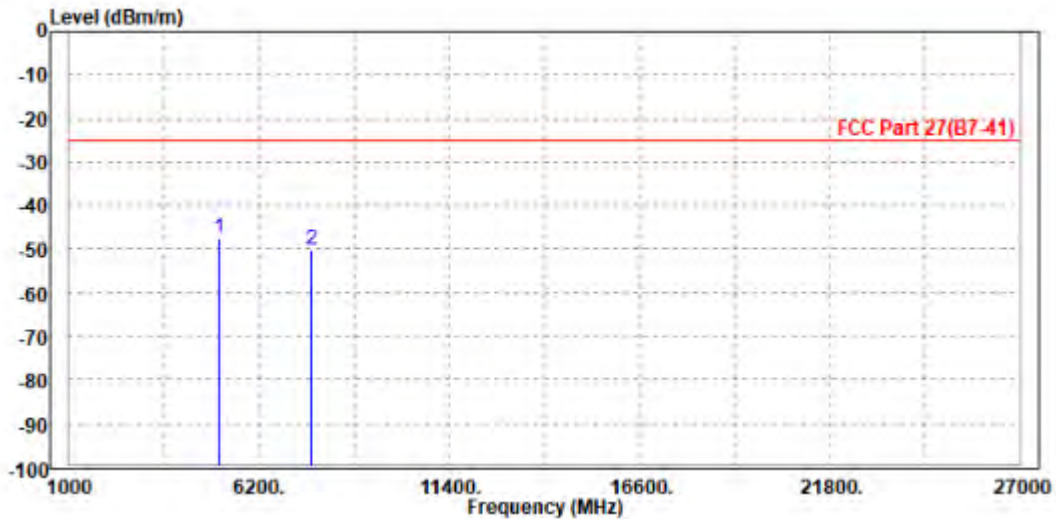



Test Report No.: W7L-P22030013RF03

| | | | |
|--------------------------------------------------------------|------------------|------------------------|---------------|
| MODE | TX channel 21100 | FREQUENCY RANGE | Above 1000MHz |
| ENVIRONMENTAL CONDITIONS | 23deg. C, 70%RH | INPUT POWER | AC 120V/60HZ |
| TESTED BY | Jace Hu | | |
| ANTENNA POLARITY & TEST DISTANCE: VERTICAL AT 3 M | | | |

| | Freq | Level | Read Level | Limit Line | Over Limit | Factor | Remark | Pol/Phase |
|---|-------------|--------|------------|------------|------------|--------|--------|-----------|
| | MHz | dBm/m | dBm | dBm/m | dB | dB/m | | |
| 1 | PP 5070.000 | -48.42 | -58.29 | -25.00 | -23.42 | 9.87 | Peak | Vertical |
| 2 | 7604.000 | -49.12 | -61.90 | -25.00 | -24.12 | 12.78 | Peak | Vertical |

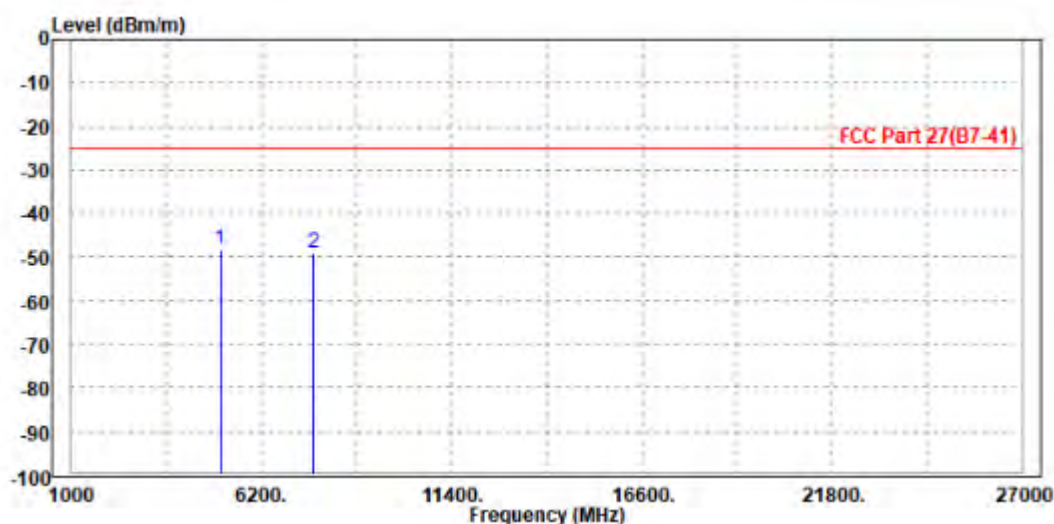



BUREAU VERITAS

Test Report No.: W7L-P22030013RF03

CH21375

| | | | |
|-----------------------------------------------------|------------------|-----------------|---------------|
| MODE | TX channel 21375 | FREQUENCY RANGE | Above 1000MHz |
| ENVIRONMENTAL CONDITIONS | 23deg. C, 70%RH | INPUT POWER | AC 120V/60HZ |
| TESTED BY | Jace Hu | | |
| ANTENNA POLARITY & TEST DISTANCE: HORIZONTAL AT 3 M | | | |

| | Freq | Level | Read Level | Limit Line | Over Limit | Factor | Remark | Pol/Phase |
|------|----------|--------|------------|------------|------------|--------|--------|------------|
| | MHz | dBm/m | dBm | dBm/m | dB | dB/m | | |
| 1 PP | 5134.000 | -49.46 | -58.39 | -25.00 | -24.46 | 8.93 | Peak | Horizontal |
| 2 | 7687.500 | -49.74 | -61.18 | -25.00 | -24.74 | 11.44 | Peak | Horizontal |

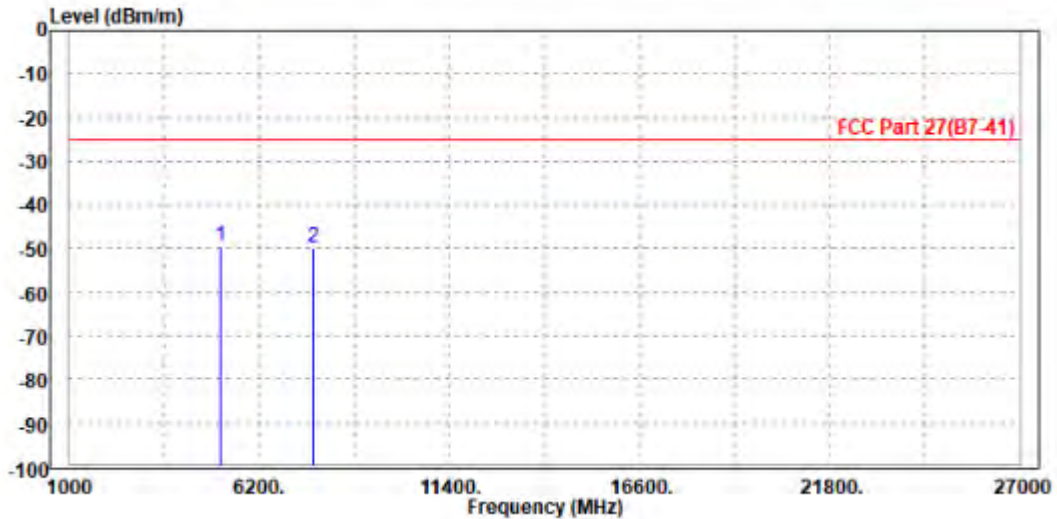



Test Report No.: W7L-P22030013RF03

| | | | |
|--------------------------------------------------------------|------------------|------------------------|---------------|
| MODE | TX channel 21375 | FREQUENCY RANGE | Above 1000MHz |
| ENVIRONMENTAL CONDITIONS | 23deg. C, 70%RH | INPUT POWER | AC 120V/60HZ |
| TESTED BY | Jace Hu | | |
| ANTENNA POLARITY & TEST DISTANCE: VERTICAL AT 3 M | | | |

| | Freq | Level | Read Level | Limit Line | Over Limit | Factor | Remark | Pol/Phase |
|---|-------------|--------|------------|------------|------------|--------|--------|-----------|
| | MHz | dBm/m | dBm | dBm/m | dB | dB/m | | |
| 1 | PP 5134.000 | -47.97 | -57.82 | -25.00 | -22.97 | 9.85 | Peak | Vertical |
| 2 | 7687.500 | -48.43 | -61.24 | -25.00 | -23.43 | 12.81 | Peak | Vertical |

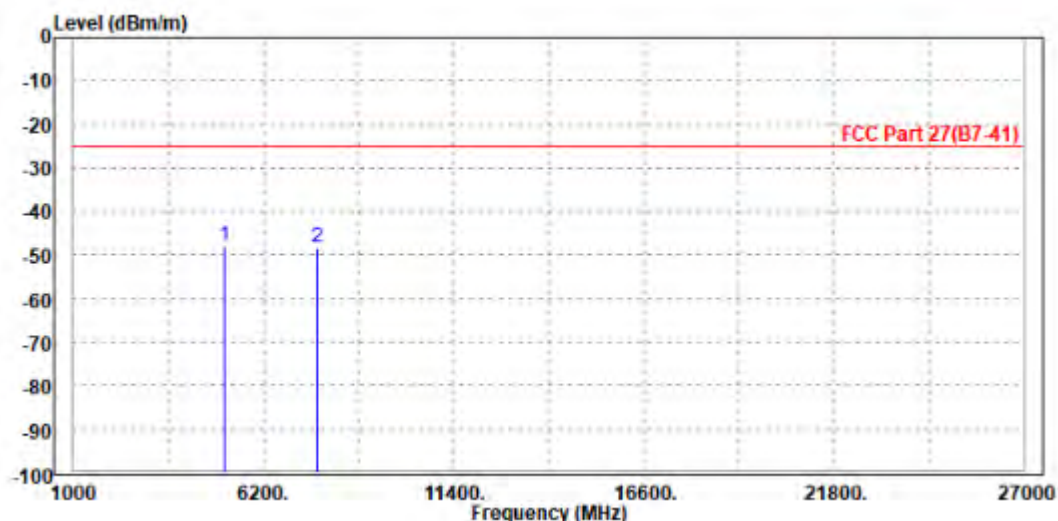



BUREAU
VERITAS

Test Report No.: W7L-P22030013RF03

CHANNEL BANDWIDTH: 20MHz / QPSK

| | | | |
|-----------------------------------------------------|------------------|-----------------|---------------|
| MODE | TX channel 21100 | FREQUENCY RANGE | Above 1000MHz |
| ENVIRONMENTAL CONDITIONS | 23deg. C, 70%RH | INPUT POWER | AC 120V/60HZ |
| TESTED BY | Jace Hu | | |
| ANTENNA POLARITY & TEST DISTANCE: HORIZONTAL AT 3 M | | | |

| | Freq | Level | Read Level | Limit Line | Over Limit | Factor | Remark | Pol/Phase |
|---|-------------|--------|------------|------------|------------|--------|--------|------------|
| | MHz | dBm/m | dBm | dBm/m | dB | dB/m | | |
| 1 | PP 5082.000 | -49.70 | -58.47 | -25.00 | -24.70 | 8.77 | Peak | Horizontal |
| 2 | 7605.000 | -50.29 | -61.69 | -25.00 | -25.29 | 11.40 | Peak | Horizontal |

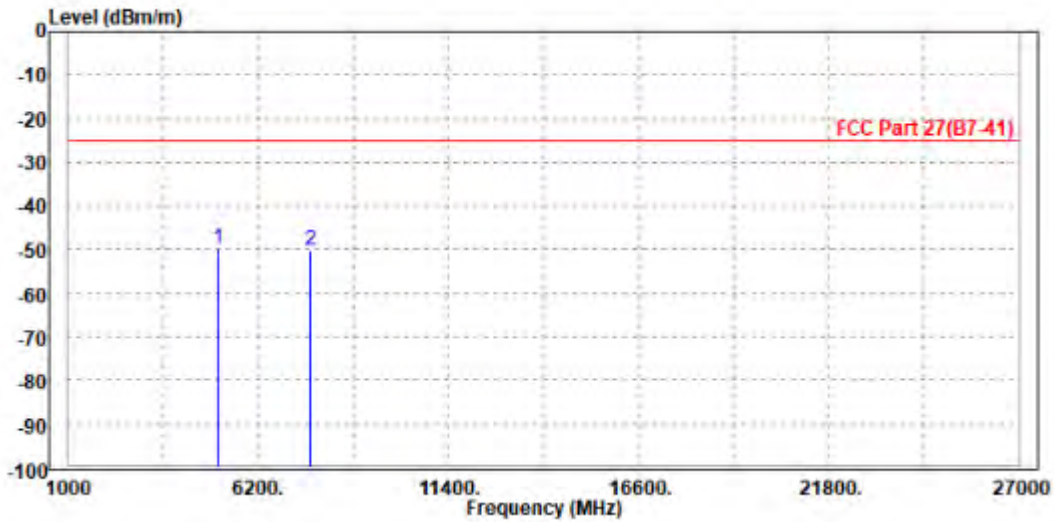



Test Report No.: W7L-P22030013RF03

| | | | |
|--------------------------------------------------------------|------------------|------------------------|---------------|
| MODE | TX channel 21100 | FREQUENCY RANGE | Above 1000MHz |
| ENVIRONMENTAL CONDITIONS | 23deg. C, 70%RH | INPUT POWER | AC 120V/60HZ |
| TESTED BY | Jace Hu | | |
| ANTENNA POLARITY & TEST DISTANCE: VERTICAL AT 3 M | | | |

| | Freq | Level | Read Level | Limit Line | Over Limit | Factor | Remark | Pol/Phase |
|---|-------------|--------|------------|------------|------------|--------|--------|-----------|
| | MHz | dBm/m | dBm | dBm/m | dB | dB/m | | |
| 1 | PP 5082.000 | -47.77 | -57.64 | -25.00 | -22.77 | 9.87 | Peak | Vertical |
| 2 | 7605.000 | -48.66 | -61.44 | -25.00 | -23.66 | 12.78 | Peak | Vertical |

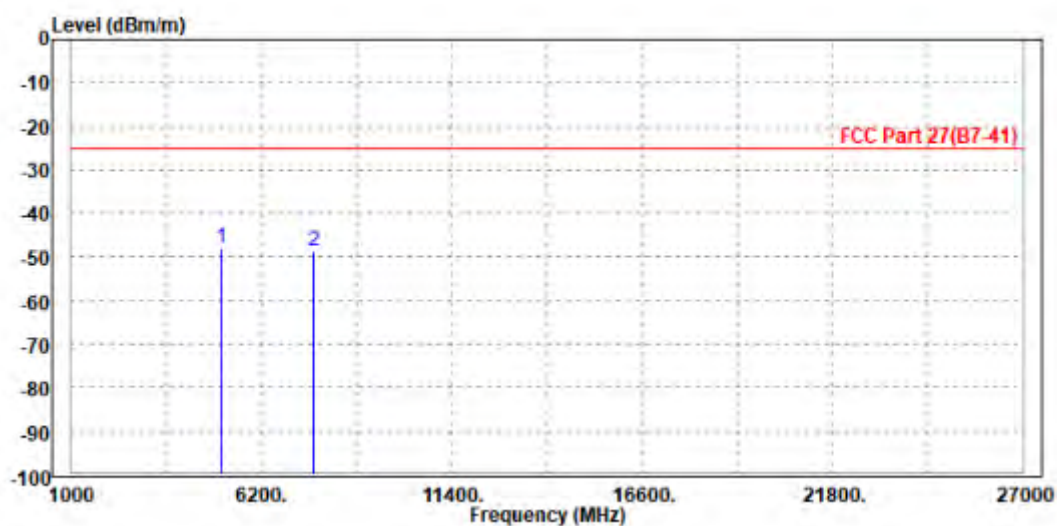

3.7 PEAK TO AVERAGE RATIO

3.7.1 LIMITS OF PEAK TO AVERAGE RATIO MEASUREMENT

In measuring transmissions in this band using an average power technique, the peak to-average ratio (PAR) of the transmission may not exceed 13 dB

3.7.2 TEST SETUP

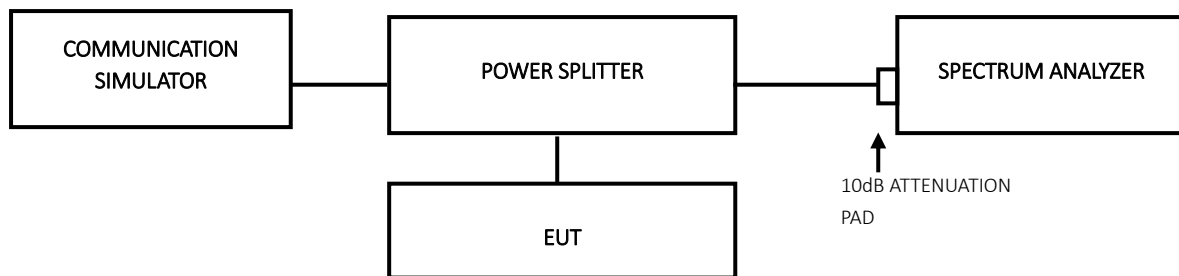

3.7.3 TEST PROCEDURES

1. Set resolution/measurement bandwidth \geq signal's occupied bandwidth;
2. Set the number of counts to a value that stabilizes the measured CCDF curve;
3. Record the maximum PAPR level associated with a probability of 0.1%.



Test Report No.: W7L-P22030013RF03

3.7.4 TEST RESULTS

Please Refer to Appendix Of this test report.



Test Report No.: W7L-P22030013RF03

4 INFORMATION ON THE TESTING LABORATORIES

We, BV 7LAYERS COMMUNICATIONS TECHNOLOGY (SHENZHEN) CO., LTD., were founded in 2015 to provide our best service in EMC, Radio, Telecom and Safety consultation. Our laboratories are accredited and approved according to ISO/IEC 17025.

If you have any comments, please feel free to contact us at the following:

Shenzhen EMC/RF Lab:

Tel: +86-755-88696566

Fax: +86-755-88696577

Email: customerservice.sw@bureauveritas.com

Web Site: www.adt.com.tw

The address and road map of all our labs can be found in our web site also.



Test Report No.: W7L-P22030013RF03

5 MODIFICATIONS RECORDERS FOR ENGINEERING CHANGES TO THE EUT BY THE LAB

No any modifications are made to the EUT by the lab during the test.



Appendix

PEAK-TO-AVERAGE RATIO(CCDF)

Test Result

| Band | Bandwidth | Modulation | Channel | RB Configuration | Result(dB) | Limit(dB) | Verdict |
|-------|-----------|------------|---------|------------------|------------|-----------|---------|
| Band7 | 5MHz | QPSK | 20775 | 1RB#0 | 5.00 | 13 | PASS |
| Band7 | 5MHz | QPSK | 20775 | 25RB#0 | 5.59 | 13 | PASS |
| Band7 | 5MHz | QPSK | 21100 | 1RB#0 | 5.22 | 13 | PASS |
| Band7 | 5MHz | QPSK | 21100 | 25RB#0 | 5.67 | 13 | PASS |
| Band7 | 5MHz | QPSK | 21425 | 1RB#0 | 4.74 | 13 | PASS |
| Band7 | 5MHz | QPSK | 21425 | 25RB#0 | 5.59 | 13 | PASS |
| Band7 | 5MHz | 16QAM | 20775 | 1RB#0 | 6.02 | 13 | PASS |
| Band7 | 5MHz | 16QAM | 20775 | 25RB#0 | 6.33 | 13 | PASS |
| Band7 | 5MHz | 16QAM | 21100 | 1RB#0 | 5.90 | 13 | PASS |
| Band7 | 5MHz | 16QAM | 21100 | 25RB#0 | 6.43 | 13 | PASS |
| Band7 | 5MHz | 16QAM | 21425 | 1RB#0 | 5.87 | 13 | PASS |
| Band7 | 5MHz | 16QAM | 21425 | 25RB#0 | 6.30 | 13 | PASS |
| Band7 | 10MHz | QPSK | 20800 | 1RB#0 | 5.16 | 13 | PASS |
| Band7 | 10MHz | QPSK | 20800 | 50RB#0 | 5.80 | 13 | PASS |
| Band7 | 10MHz | QPSK | 21100 | 1RB#0 | 5.32 | 13 | PASS |
| Band7 | 10MHz | QPSK | 21100 | 50RB#0 | 5.86 | 13 | PASS |
| Band7 | 10MHz | QPSK | 21400 | 1RB#0 | 5.10 | 13 | PASS |
| Band7 | 10MHz | QPSK | 21400 | 50RB#0 | 5.71 | 13 | PASS |
| Band7 | 10MHz | 16QAM | 20800 | 1RB#0 | 5.29 | 13 | PASS |
| Band7 | 10MHz | 16QAM | 20800 | 50RB#0 | 6.44 | 13 | PASS |
| Band7 | 10MHz | 16QAM | 21100 | 1RB#0 | 5.75 | 13 | PASS |
| Band7 | 10MHz | 16QAM | 21100 | 50RB#0 | 6.44 | 13 | PASS |
| Band7 | 10MHz | 16QAM | 21400 | 1RB#0 | 5.03 | 13 | PASS |
| Band7 | 10MHz | 16QAM | 21400 | 50RB#0 | 6.37 | 13 | PASS |
| Band7 | 15MHz | QPSK | 20825 | 1RB#0 | 5.07 | 13 | PASS |
| Band7 | 15MHz | QPSK | 20825 | 75RB#0 | 6.05 | 13 | PASS |
| Band7 | 15MHz | QPSK | 21100 | 1RB#0 | 5.32 | 13 | PASS |
| Band7 | 15MHz | QPSK | 21100 | 75RB#0 | 6.05 | 13 | PASS |
| Band7 | 15MHz | QPSK | 21375 | 1RB#0 | 5.18 | 13 | PASS |
| Band7 | 15MHz | QPSK | 21375 | 75RB#0 | 5.94 | 13 | PASS |
| Band7 | 15MHz | 16QAM | 20825 | 1RB#0 | 5.87 | 13 | PASS |
| Band7 | 15MHz | 16QAM | 20825 | 75RB#0 | 6.50 | 13 | PASS |
| Band7 | 15MHz | 16QAM | 21100 | 1RB#0 | 6.00 | 13 | PASS |
| Band7 | 15MHz | 16QAM | 21100 | 75RB#0 | 6.49 | 13 | PASS |
| Band7 | 15MHz | 16QAM | 21375 | 1RB#0 | 5.36 | 13 | PASS |
| Band7 | 15MHz | 16QAM | 21375 | 75RB#0 | 6.42 | 13 | PASS |
| Band7 | 20MHz | QPSK | 20850 | 1RB#0 | 4.99 | 13 | PASS |
| Band7 | 20MHz | QPSK | 20850 | 100RB#0 | 5.74 | 13 | PASS |
| Band7 | 20MHz | QPSK | 21100 | 1RB#0 | 5.23 | 13 | PASS |
| Band7 | 20MHz | QPSK | 21100 | 100RB#0 | 5.80 | 13 | PASS |
| Band7 | 20MHz | QPSK | 21350 | 1RB#0 | 5.14 | 13 | PASS |
| Band7 | 20MHz | QPSK | 21350 | 100RB#0 | 5.68 | 13 | PASS |
| Band7 | 20MHz | 16QAM | 20850 | 1RB#0 | 5.72 | 13 | PASS |



BUREAU
VERITAS

Test Report No.: W7L-P22030013RF03

| | | | | | | | |
|-------|-------|-------|-------|---------|------|----|------|
| Band7 | 20MHz | 16QAM | 20850 | 100RB#0 | 6.49 | 13 | PASS |
| Band7 | 20MHz | 16QAM | 21100 | 1RB#0 | 5.87 | 13 | PASS |
| Band7 | 20MHz | 16QAM | 21100 | 100RB#0 | 6.46 | 13 | PASS |
| Band7 | 20MHz | 16QAM | 21350 | 1RB#0 | 5.80 | 13 | PASS |
| Band7 | 20MHz | 16QAM | 21350 | 100RB#0 | 6.42 | 13 | PASS |

Test Graphs

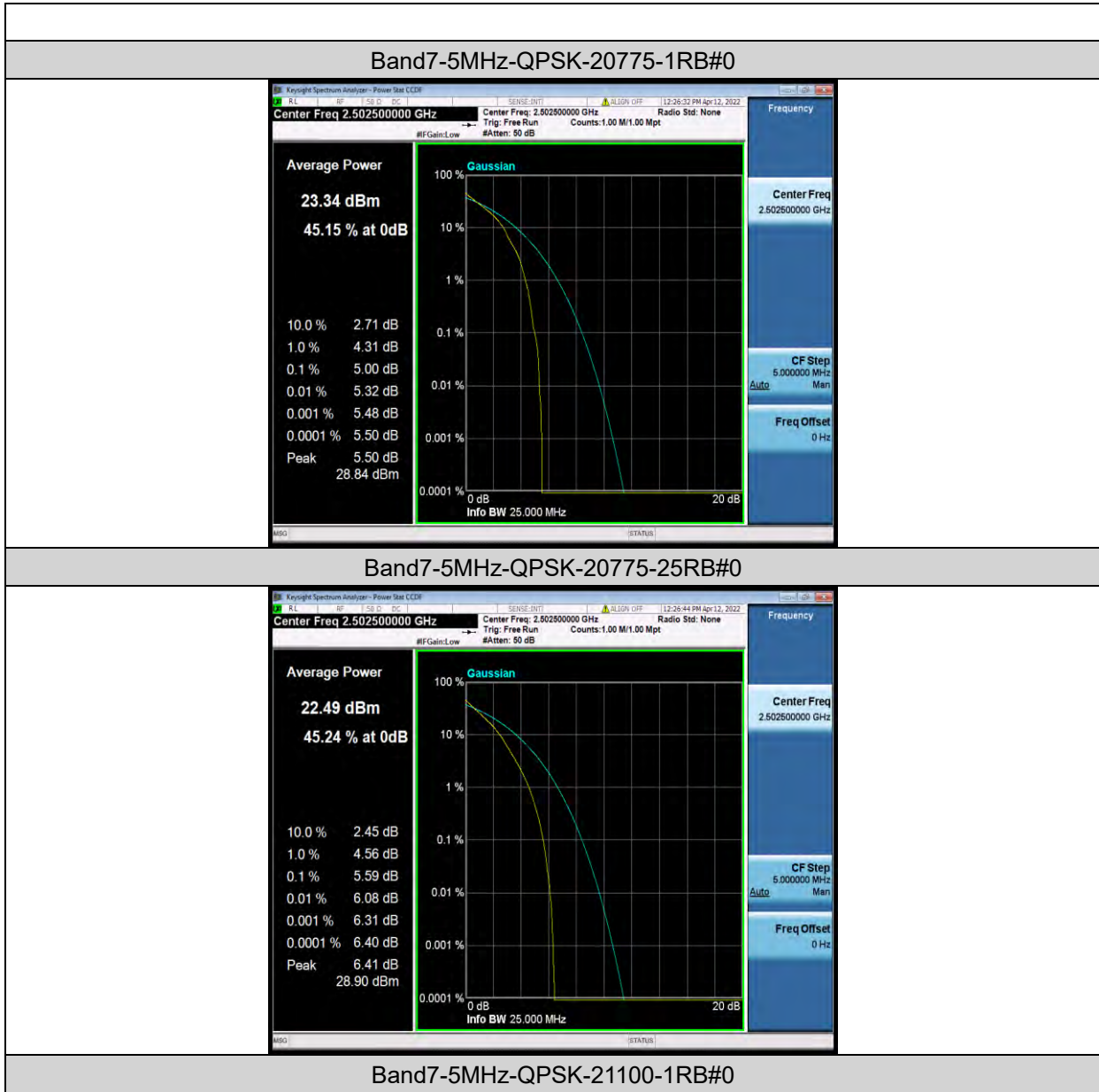



BUREAU VERITAS

Test Report No.: W7L-P22030013RF03

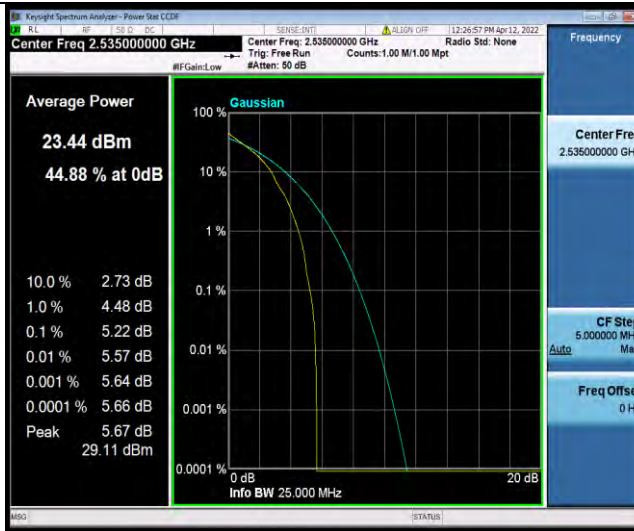

Band7-5MHz-QPSK-21100-25RB#0



Band7-5MHz-QPSK-21425-1RB#0

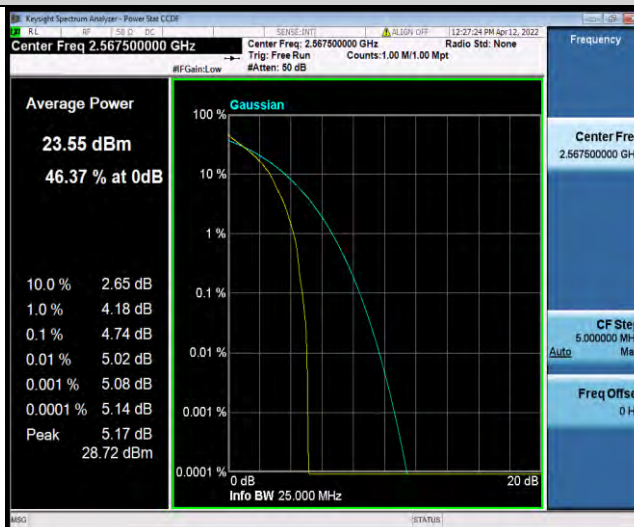

Band7-5MHz-QPSK-21425-25RB#0



BUREAU VERITAS

Test Report No.: W7L-P22030013RF03



Band7-5MHz-16QAM-20775-1RB#0



Band7-5MHz-16QAM-20775-25RB#0

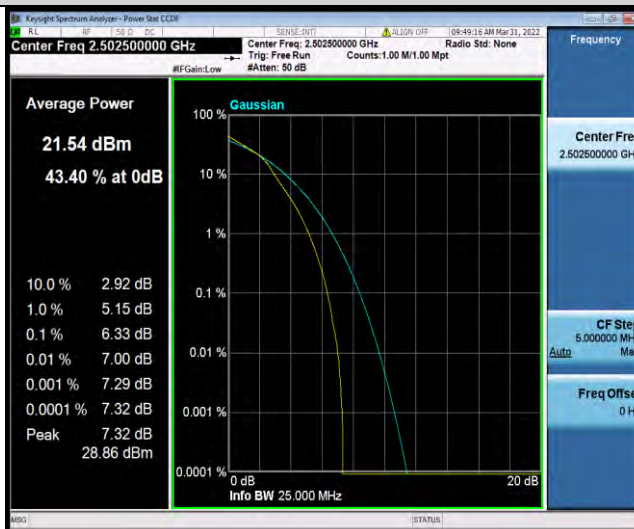

Band7-5MHz-16QAM-21100-1RB#0



BUREAU VERITAS

Test Report No.: W7L-P22030013RF03



Band7-5MHz-16QAM-21100-25RB#0

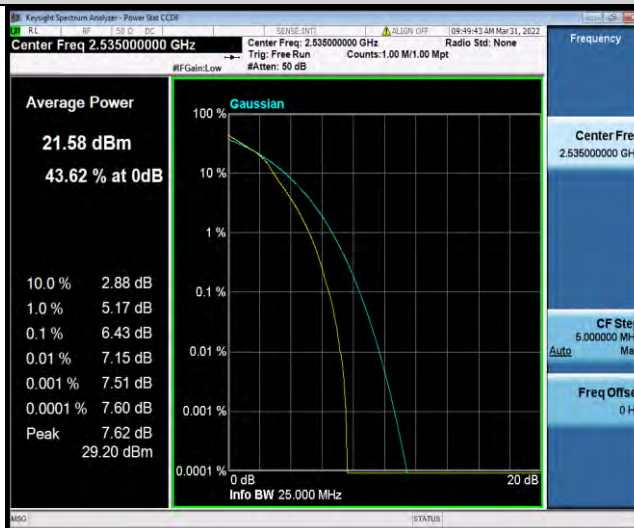

Band7-5MHz-16QAM-21425-1RB#0

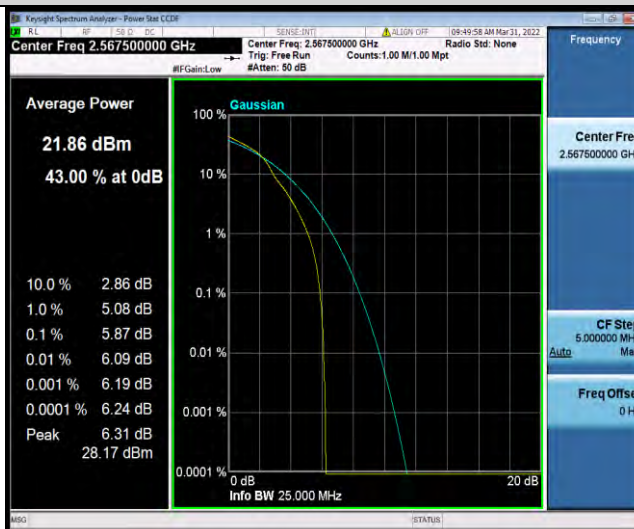

Band7-5MHz-16QAM-21425-25RB#0



BUREAU VERITAS

Test Report No.: W7L-P22030013RF03



Band7-10MHz-QPSK-20800-1RB#0



Band7-10MHz-QPSK-20800-50RB#0

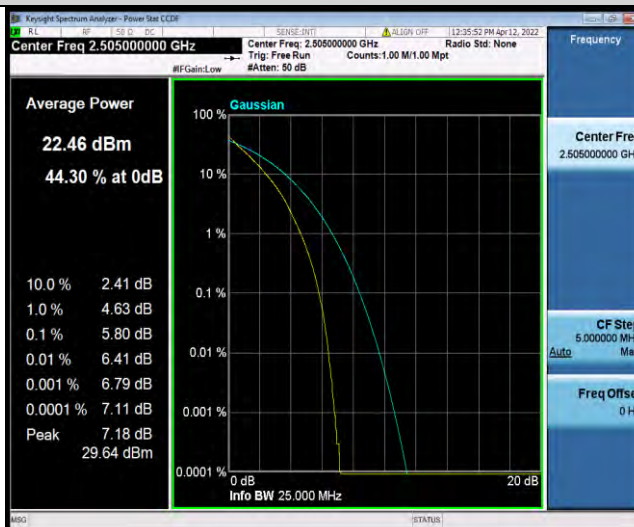

Band7-10MHz-QPSK-21100-1RB#0



BUREAU VERITAS

Test Report No.: W7L-P22030013RF03



Band7-10MHz-QPSK-21100-50RB#0

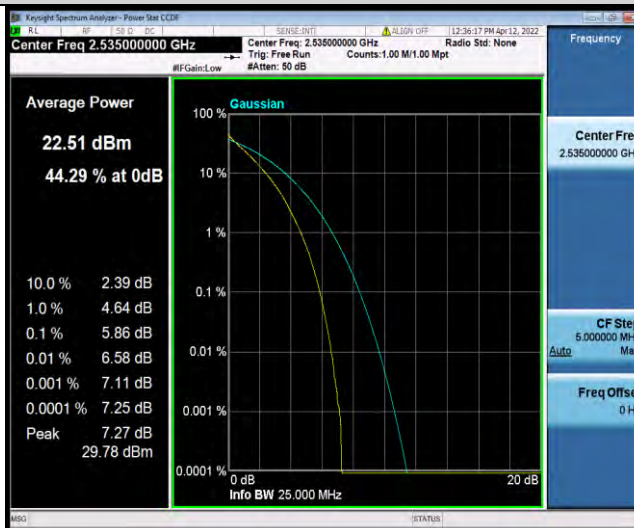

Band7-10MHz-QPSK-21400-1RB#0

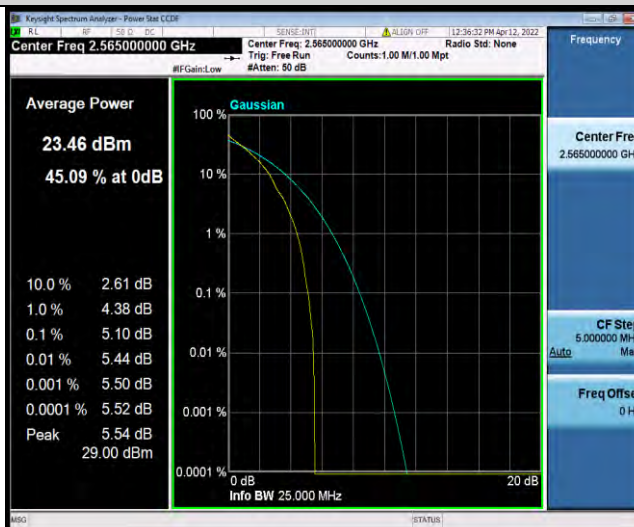

Band7-10MHz-QPSK-21400-50RB#0



BUREAU VERITAS

Test Report No.: W7L-P22030013RF03

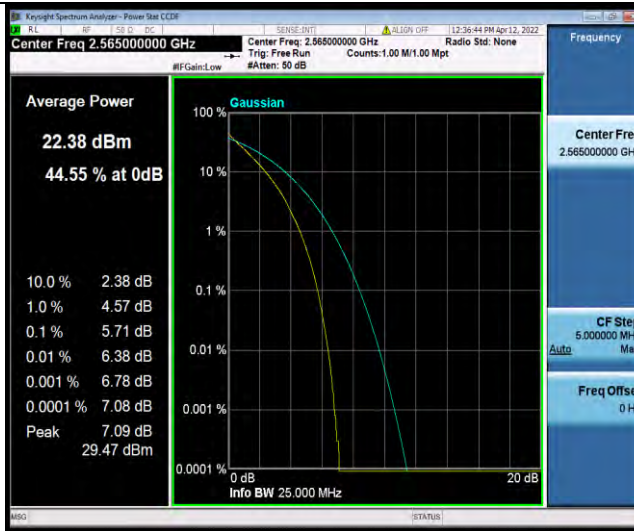

Band7-10MHz-16QAM-20800-1RB#0

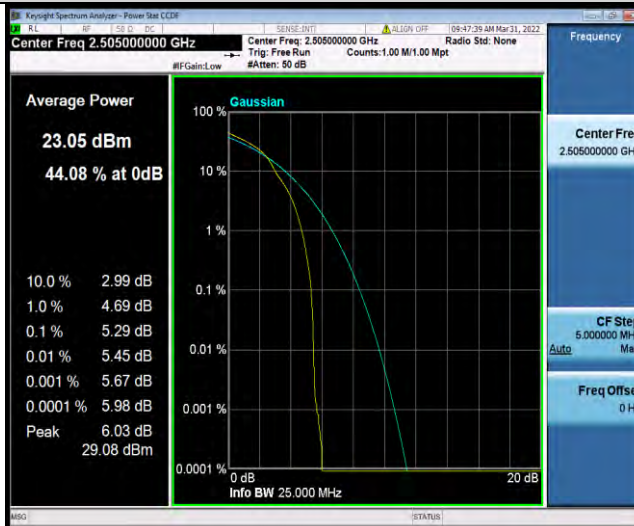

Band7-10MHz-16QAM-20800-50RB#0

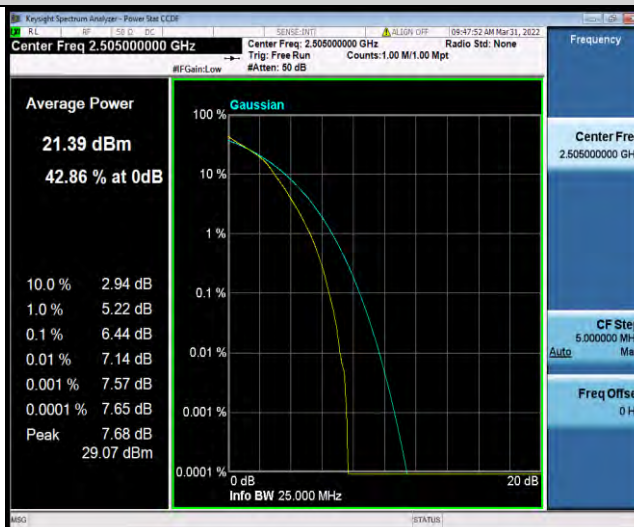

Band7-10MHz-16QAM-21100-1RB#0



BUREAU VERITAS

Test Report No.: W7L-P22030013RF03



Band7-10MHz-16QAM-21100-50RB#0

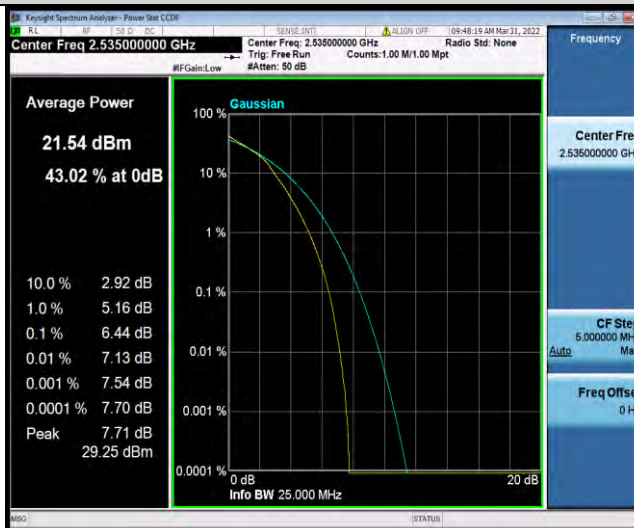

Band7-10MHz-16QAM-21400-1RB#0

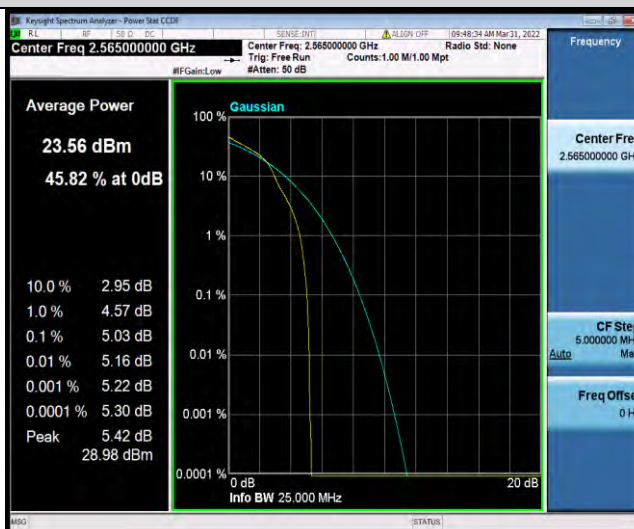

Band7-10MHz-16QAM-21400-50RB#0



BUREAU VERITAS

Test Report No.: W7L-P22030013RF03

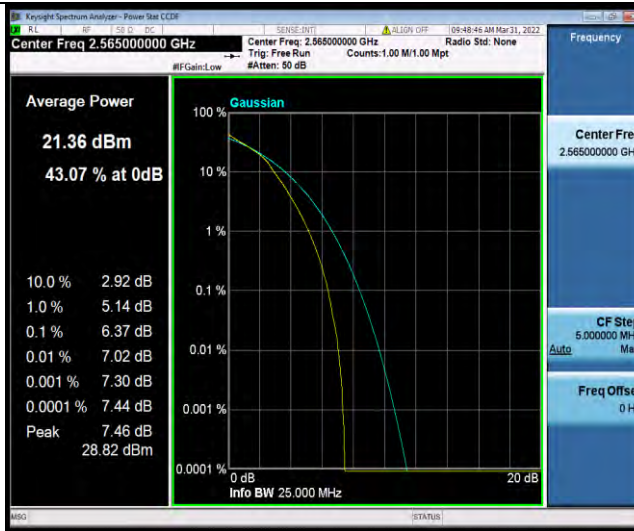

Band7-15MHz-QPSK-20825-1RB#0

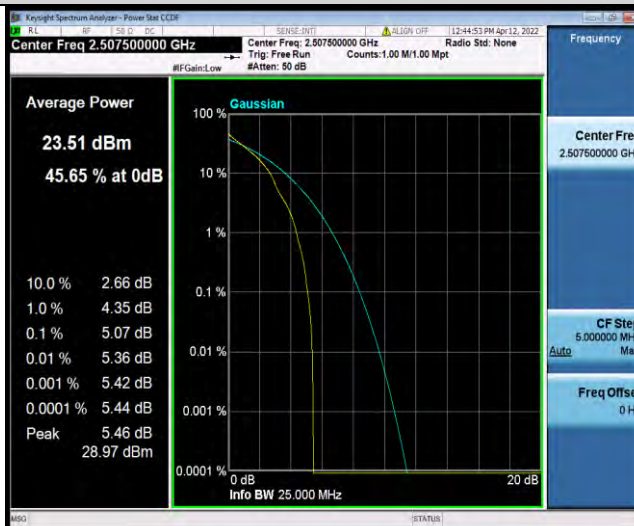

Band7-15MHz-QPSK-20825-75RB#0



Band7-15MHz-QPSK-21100-1RB#0



BUREAU VERITAS

Test Report No.: W7L-P22030013RF03

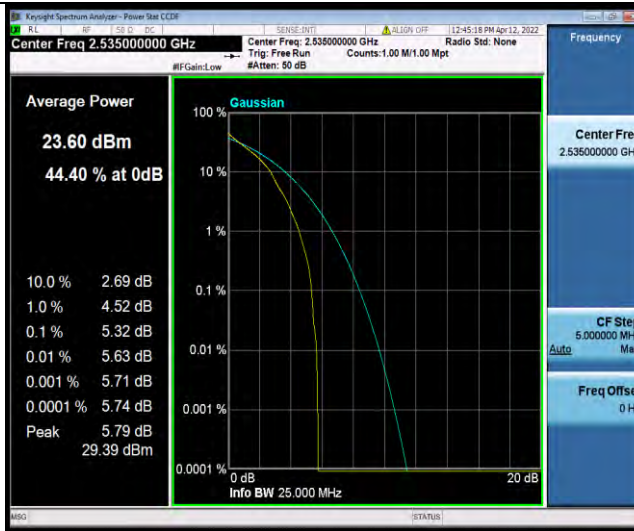

Band7-15MHz-QPSK-21100-75RB#0

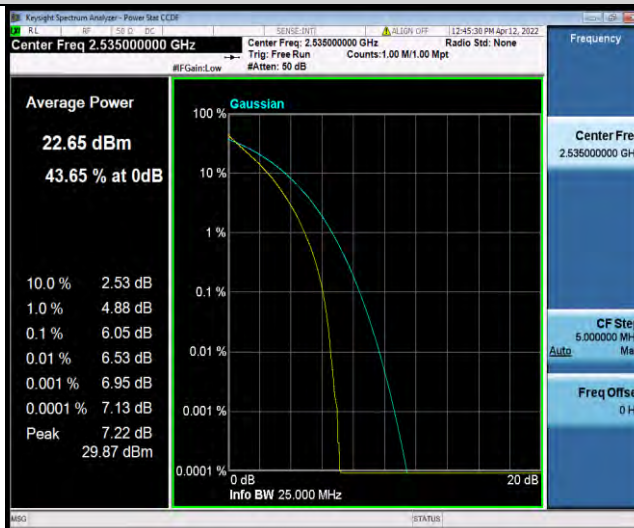

Band7-15MHz-QPSK-21375-1RB#0

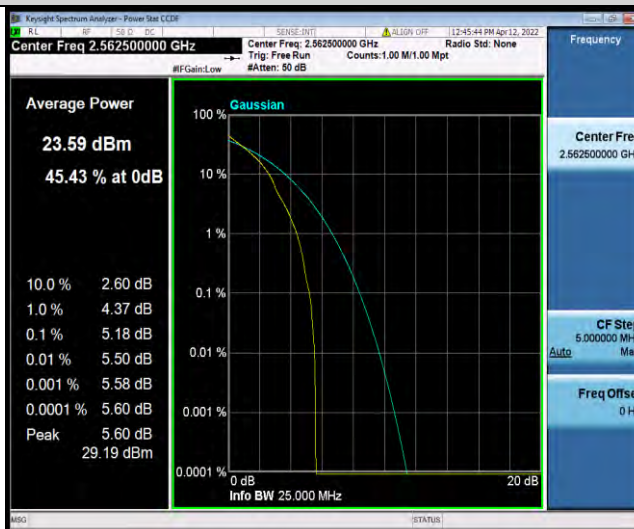

Band7-15MHz-QPSK-21375-75RB#0



BUREAU VERITAS

Test Report No.: W7L-P22030013RF03



Band7-15MHz-16QAM-20825-1RB#0



Band7-15MHz-16QAM-20825-75RB#0

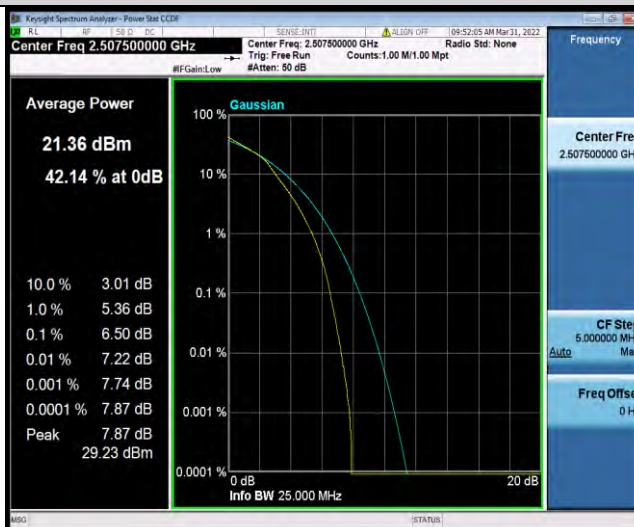

Band7-15MHz-16QAM-21100-1RB#0



BUREAU VERITAS

Test Report No.: W7L-P22030013RF03



Band7-15MHz-16QAM-21100-75RB#0

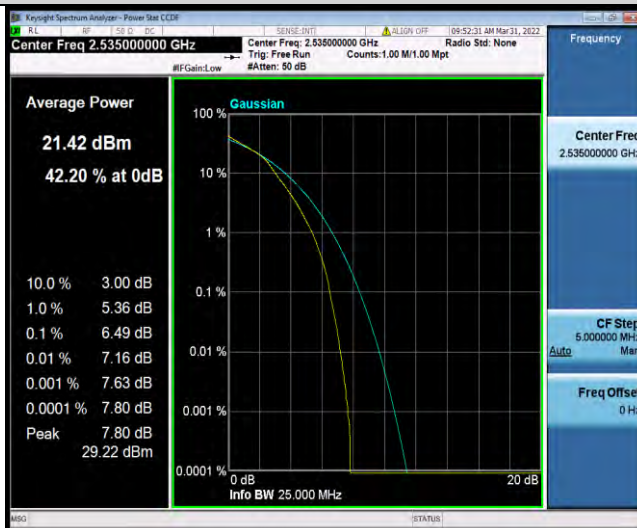

Band7-15MHz-16QAM-21375-1RB#0

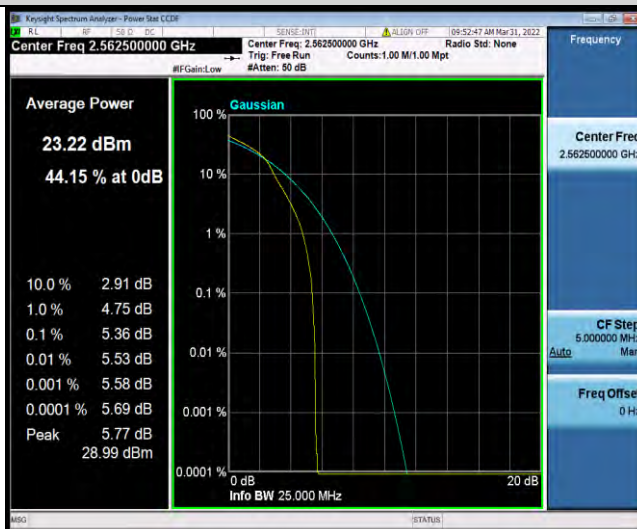

Band7-15MHz-16QAM-21375-75RB#0



BUREAU VERITAS

Test Report No.: W7L-P22030013RF03

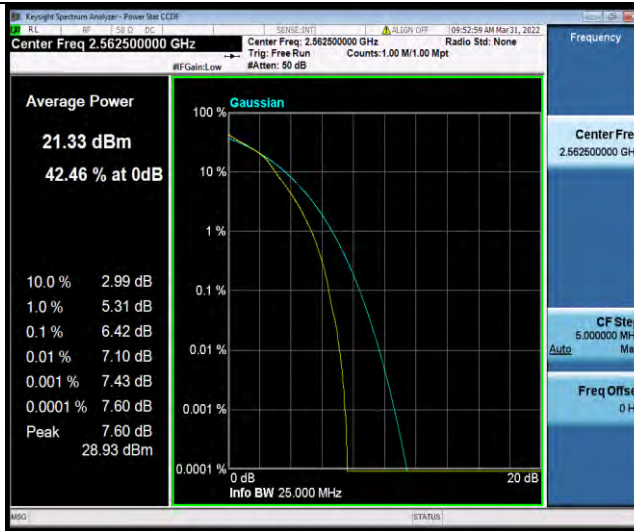

Band7-20MHz-QPSK-20850-1RB#0

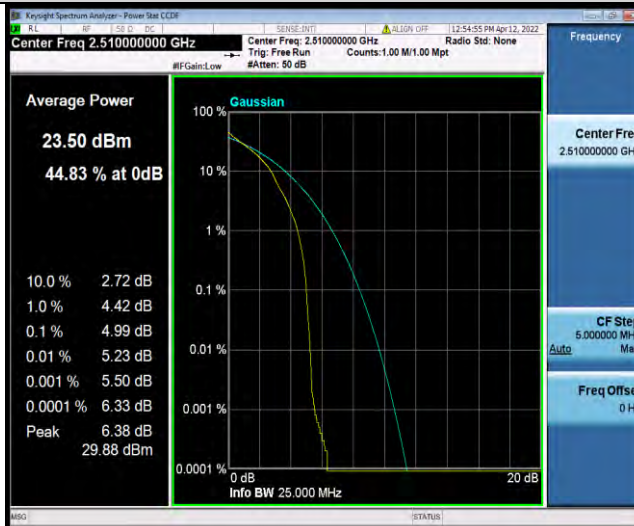

Band7-20MHz-QPSK-20850-100RB#0

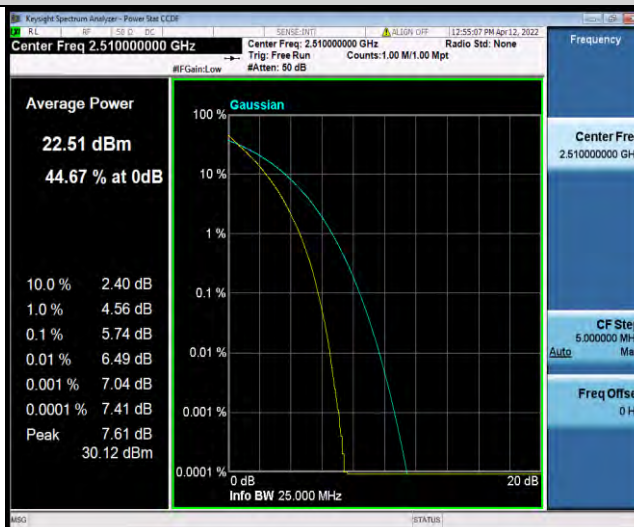

Band7-20MHz-QPSK-21100-1RB#0



BUREAU VERITAS

Test Report No.: W7L-P22030013RF03



Band7-20MHz-QPSK-21100-100RB#0

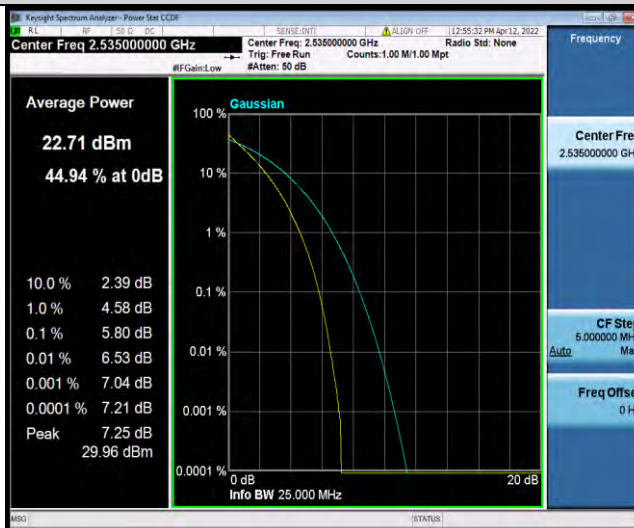

Band7-20MHz-QPSK-21350-1RB#0

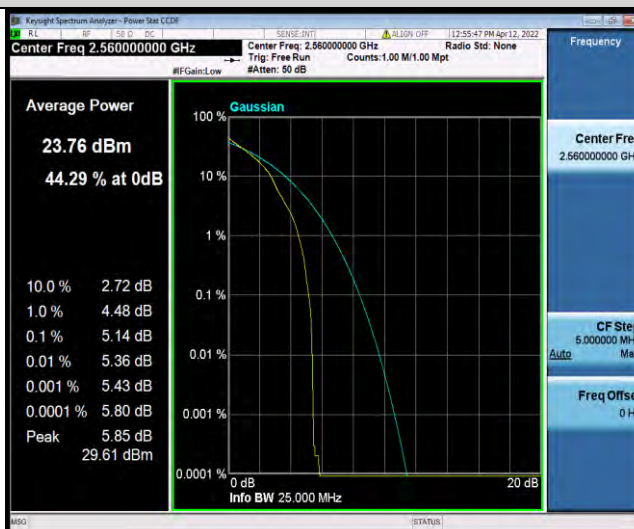

Band7-20MHz-QPSK-21350-100RB#0



BUREAU VERITAS

Test Report No.: W7L-P22030013RF03

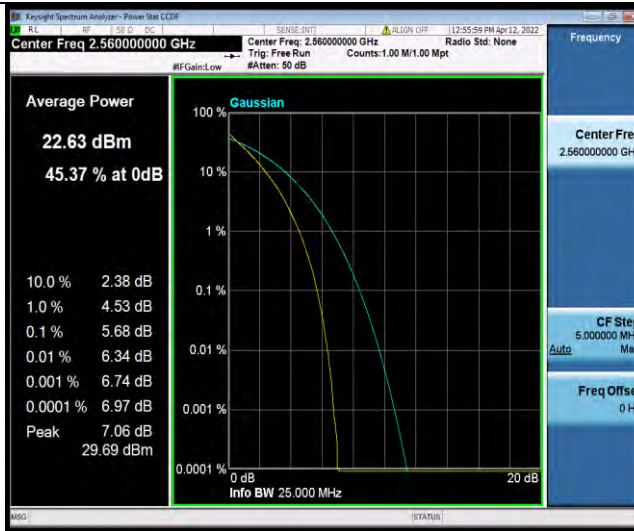

Band7-20MHz-16QAM-20850-1RB#0



Band7-20MHz-16QAM-20850-100RB#0

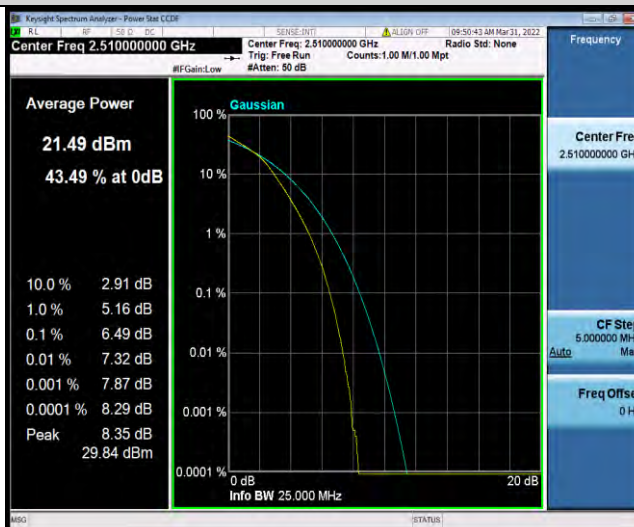

Band7-20MHz-16QAM-21100-1RB#0



BUREAU VERITAS

Test Report No.: W7L-P22030013RF03



Band7-20MHz-16QAM-21100-100RB#0

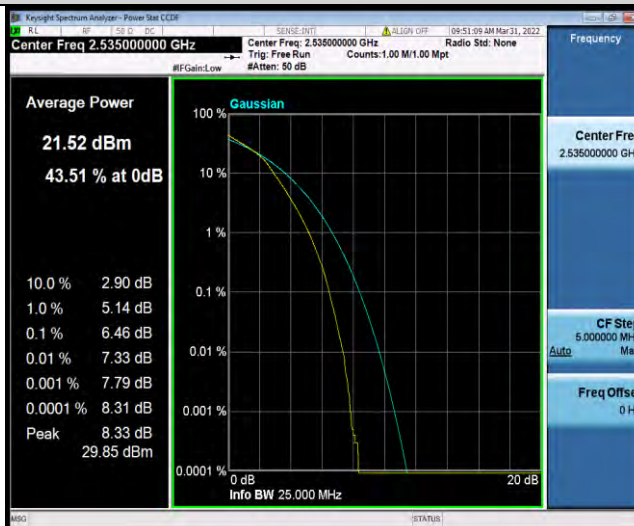

Band7-20MHz-16QAM-21350-1RB#0

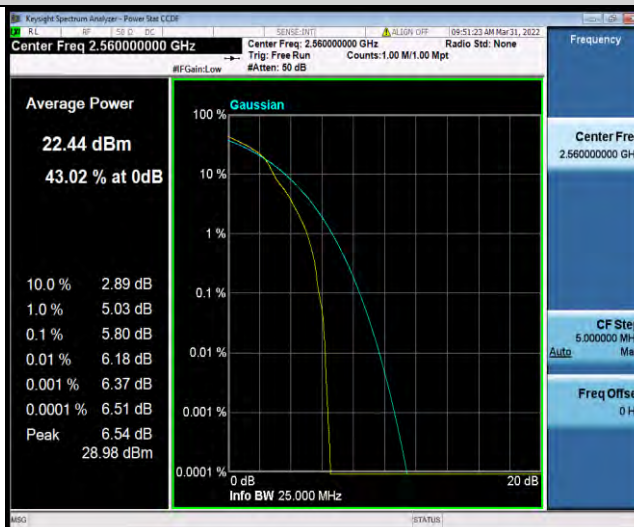

Band7-20MHz-16QAM-21350-100RB#0



BUREAU
VERITAS

Test Report No.: W7L-P22030013RF03





Test Report No.: W7L-P22030013RF03

26DB BANDWIDTH AND OCCUPIED BANDWIDTH

Test Result

| Band | Bandwidth | Modulation | Channel | RB Configuration | Occupied Bandwidth (MHz) | 26dB Bandwidth (MHz) | Verdict |
|-------|-----------|------------|---------|------------------|--------------------------|----------------------|---------|
| Band7 | 5MHz | QPSK | 20775 | 25RB#0 | 4.4988 | 4.864 | PASS |
| Band7 | 5MHz | QPSK | 21100 | 25RB#0 | 4.4908 | 4.876 | PASS |
| Band7 | 5MHz | QPSK | 21425 | 25RB#0 | 4.4986 | 4.879 | PASS |
| Band7 | 5MHz | 16QAM | 20775 | 25RB#0 | 4.4998 | 4.876 | PASS |
| Band7 | 5MHz | 16QAM | 21100 | 25RB#0 | 4.4961 | 4.898 | PASS |
| Band7 | 5MHz | 16QAM | 21425 | 25RB#0 | 4.5037 | 4.872 | PASS |
| Band7 | 10MHz | QPSK | 20800 | 50RB#0 | 8.9812 | 9.565 | PASS |
| Band7 | 10MHz | QPSK | 21100 | 50RB#0 | 8.9830 | 9.579 | PASS |
| Band7 | 10MHz | QPSK | 21400 | 50RB#0 | 8.9734 | 9.572 | PASS |
| Band7 | 10MHz | 16QAM | 20800 | 50RB#0 | 8.9747 | 9.602 | PASS |
| Band7 | 10MHz | 16QAM | 21100 | 50RB#0 | 8.9822 | 9.597 | PASS |
| Band7 | 10MHz | 16QAM | 21400 | 50RB#0 | 8.9803 | 9.599 | PASS |
| Band7 | 15MHz | QPSK | 20825 | 75RB#0 | 13.468 | 14.33 | PASS |
| Band7 | 15MHz | QPSK | 21100 | 75RB#0 | 13.454 | 14.30 | PASS |
| Band7 | 15MHz | QPSK | 21375 | 75RB#0 | 13.477 | 14.29 | PASS |
| Band7 | 15MHz | 16QAM | 20825 | 75RB#0 | 13.456 | 14.31 | PASS |
| Band7 | 15MHz | 16QAM | 21100 | 75RB#0 | 13.460 | 14.35 | PASS |
| Band7 | 15MHz | 16QAM | 21375 | 75RB#0 | 13.461 | 14.31 | PASS |
| Band7 | 20MHz | QPSK | 20850 | 100RB#0 | 17.975 | 18.98 | PASS |
| Band7 | 20MHz | QPSK | 21100 | 100RB#0 | 17.964 | 19.04 | PASS |
| Band7 | 20MHz | QPSK | 21350 | 100RB#0 | 17.961 | 19.03 | PASS |
| Band7 | 20MHz | 16QAM | 20850 | 100RB#0 | 17.958 | 19.04 | PASS |
| Band7 | 20MHz | 16QAM | 21100 | 100RB#0 | 17.978 | 19.02 | PASS |
| Band7 | 20MHz | 16QAM | 21350 | 100RB#0 | 17.977 | 19.02 | PASS |



Test Report No.: W7L-P22030013RF03

Test Graphs





BUREAU VERITAS

Test Report No.: W7L-P22030013RF03

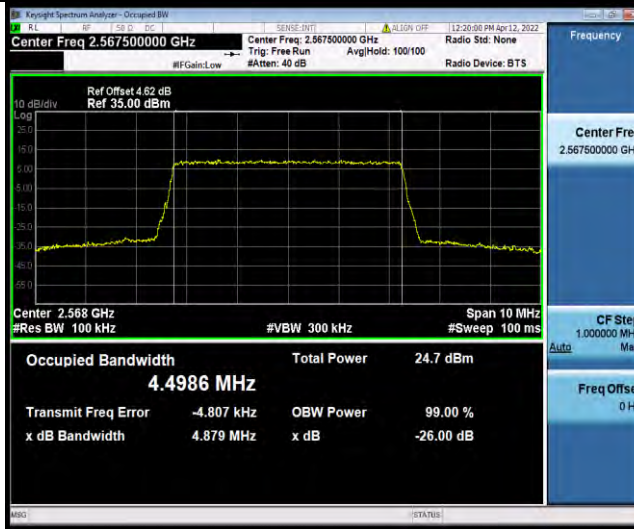

Band7-5MHz-16QAM-20775-25RB#0



Band7-5MHz-16QAM-21100-25RB#0

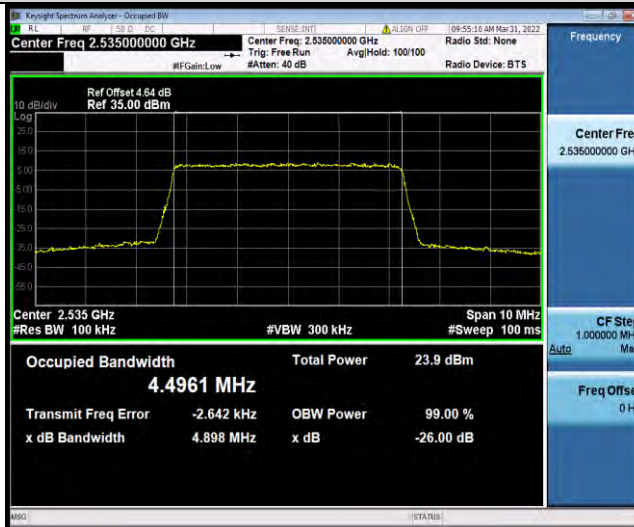

Band7-5MHz-16QAM-21425-25RB#0



BUREAU VERITAS

Test Report No.: W7L-P22030013RF03

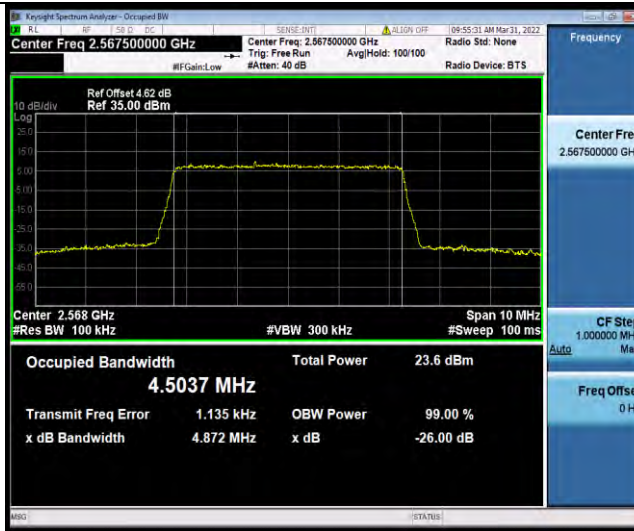

Band7-10MHz-QPSK-20800-50RB#0



Band7-10MHz-QPSK-21100-50RB#0



Band7-10MHz-QPSK-21400-50RB#0



BUREAU VERITAS

Test Report No.: W7L-P22030013RF03



Band7-10MHz-16QAM-20800-50RB#0



Band7-10MHz-16QAM-21100-50RB#0



Band7-10MHz-16QAM-21400-50RB#0



BUREAU VERITAS

Test Report No.: W7L-P22030013RF03



Band7-15MHz-QPSK-20825-75RB#0

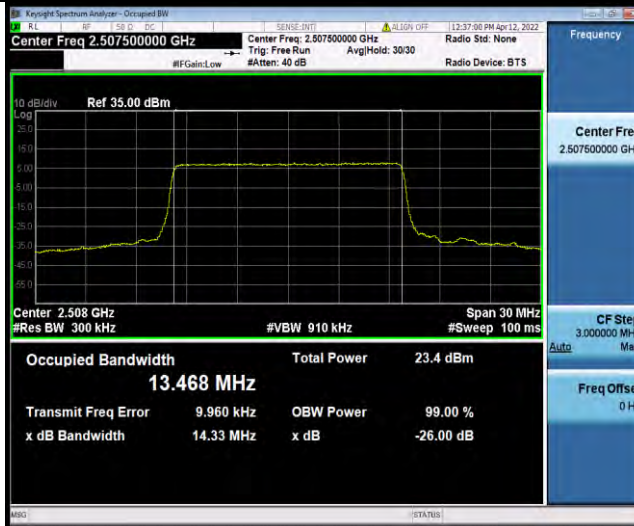

Band7-15MHz-QPSK-21100-75RB#0

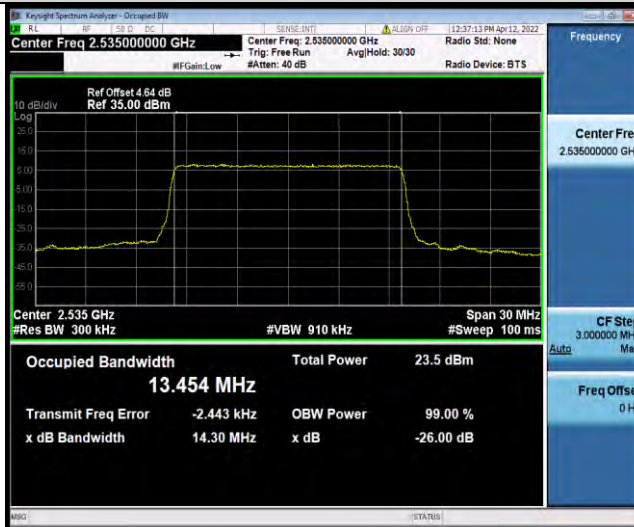

Band7-15MHz-QPSK-21375-75RB#0



BUREAU VERITAS

Test Report No.: W7L-P22030013RF03

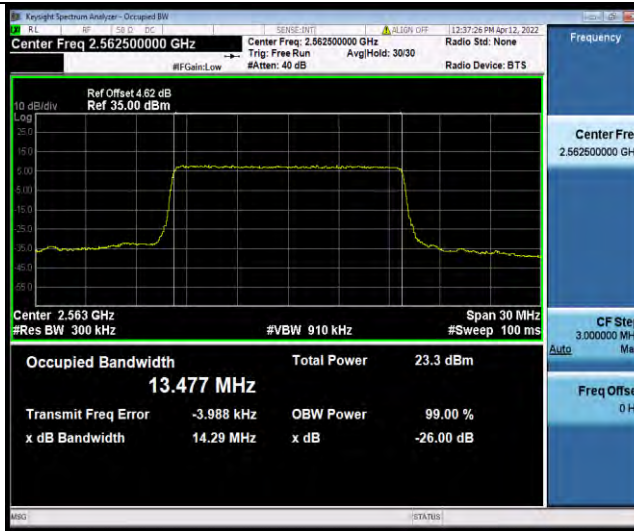

Band7-15MHz-16QAM-20825-75RB#0



Band7-15MHz-16QAM-21100-75RB#0



Band7-15MHz-16QAM-21375-75RB#0