

VARIANT FCC TEST REPORT (PART 24)

Applicant:	HMD Global Oy
Address:	Bertel Jungin aukio 9, 02600 Espoo, Finland

Manufacturer or Supplier:	HMD Global Oy
Address:	Bertel Jungin aukio 9, 02600 Espoo, Finland
Product:	Multi-band GSM/WCDMA/LTE phone with Bluetooth&WLAN
Brand Name:	NOKIA
Model Name:	TA-1401
FCC ID:	2AJOTTA-1401
Date of tests:	Nov. 25, 2021 ~ Oct. 10, 2022

The tests have been carried out according to the requirements of the following standard:

- FCC PART 24, Subpart E**
 FCC PART 2
 ANSI/TIA/EIA-603-D
 ANSI/TIA/EIA-603-E
 ANSI C63.26-2015

CONCLUSION: The submitted sample was found to COMPLY with the test requirement

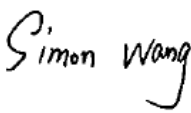
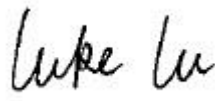
Prepared by Simon Wang Engineer / Mobile Department	Approved by Luke Lu Manager / Mobile Department
	
Date: Oct. 10, 2022	Date: Oct. 10, 2022

This report is governed by, and incorporates by reference, the Conditions of Testing as posted at the date of issuance of this report at <http://www.bureauveritas.com/home/about-us/our-business/cps/about-us/terms-conditions/> and is intended for your exclusive use. Any copying or replication of this report to or for any other person or entity, or use of our name or trademark, is permitted only with our prior written permission. This report sets forth our findings solely with respect to the test samples identified herein. The results set forth in this report are not indicative or representative of the quality or characteristics of the lot from which a test sample was taken or any similar or identical product unless specifically and expressly noted. Our report includes all of the tests requested by you and the results thereof based upon the information that you provided to us. Measurement uncertainty is only provided upon request for accredited tests. Statements of conformity are based on simple acceptance criteria without taking measurement uncertainty into account, unless otherwise requested in writing. You have 60 days from date of issuance of this report to notify us of any material error or omission caused by our negligence or if you require measurement uncertainty; provided, however, that such notice shall be in writing and shall specifically address the issue you wish to raise. A failure to raise such issue within the prescribed time shall constitute your unqualified acceptance of the completeness of this report, the tests conducted and the correctness of the report contents.



TABLE OF CONTENTS

RELEASE CONTROL RECORD	4
1 SUMMARY OF TEST RESULTS	5
1.1 MEASUREMENT UNCERTAINTY	5
1.2 TEST SITE AND INSTRUMENTS	6
2 GENERAL INFORMATION	8
2.1 GENERAL DESCRIPTION OF EUT	8
2.2 CONFIGURATION OF SYSTEM UNDER TEST	10
2.3 DESCRIPTION OF SUPPORT UNITS	11
2.4 TEST ITEM AND TEST CONFIGURATION.....	11
2.5 EUT OPERATING CONDITIONS	12
2.6 GENERAL DESCRIPTION OF APPLIED STANDARDS	12
3 TEST TYPES AND RESULTS	13
3.1 OUTPUT POWER MEASUREMENT	13
3.1.1 LIMITS OF OUTPUT POWER MEASUREMENT	13
3.1.2 TEST PROCEDURES	13
3.1.3 TEST SETUP	14
3.1.4 TEST RESULTS	14
3.2 FREQUENCY STABILITY MEASUREMENT	16
3.2.1 LIMITS OF FREQUENCY STABILITY MEASUREMENT	16
3.2.2 TEST PROCEDURE	16
3.2.3 TEST SETUP	16
3.2.4 TEST RESULTS	17
3.3 OCCUPIED BANDWIDTH MEASUREMENT	18
3.3.1 TEST PROCEDURES	18
3.3.2 TEST SETUP	18
3.3.3 TEST PROCEDURES	18
3.3.4 TEST RESULTS	19
3.4 BAND EDGE MEASUREMENTC	20
3.4.1 LIMITS OF BAND EDGE MEASUREMENT	20
3.4.2 TEST SETUP	20
3.4.3 TEST PROCEDURES	21
3.4.4. TEST RESULTS	22
3.5 CONDUCTED SPURIOUS EMISSIONS.....	23
3.5.1 LIMITS OF CONDUCTED SPURIOUS EMISSIONS MEASUREMENT	23
3.5.2 TEST PROCEDURE	23
3.5.3 TEST SETUP	23
3.5.4 TEST RESULTS	24
3.6 RADIATED EMISSION MEASUREMENT	25
3.6.1 LIMITS OF RADIATED EMISSION MEASUREMENT	25
3.6.2 TEST PROCEDURES	25



**BUREAU
VERITAS**

Test Report No.: W7L-P22090015-1RF05

3.6.3 DEVIATION FROM TEST STANDARD 25

3.6.4 TEST SETUP 26

3.6.5 TEST RESULTS 28

3.7 PEAK TO AVERAGE RATIO 42

3.7.1 LIMITS OF PEAK TO AVERAGE RATIO MEASUREMENT 42

3.7.2 TEST SETUP 42

3.7.3 TEST PROCEDURES 42

3.7.4 TEST RESULTS 43

4 INFORMATION ON THE TESTING LABORATORIES 44

5 MODIFICATIONS RECORDERS FOR ENGINEERING CHANGES TO THE EUT BY THE LAB..... 45

6 APPENDIX 46

APPENDIX A: EFFECTIVE (ISOTROPIC) RADIATED POWER OUTPUT DATA 46

TEST RESULT 46

APPENDIX B: PEAK-TO-AVERAGE RATIO(CCDF)..... 47

TEST RESULT 47

TEST GRAPHS 48

APPENDIX C: 26DB BANDWIDTH AND OCCUPIED BANDWIDTH..... 51

TEST RESULT 51

TEST GRAPHS 52

APPENDIX D: BAND EDGE..... 55

TEST RESULT 55

TEST GRAPHS 55

APPENDIX E: CONDUCTED SPURIOUS EMISSION..... 57

TEST RESULT 57

TEST GRAPHS 58

APPENDIX F: FREQUENCY STABILITY 65

TEST RESULT 65



Test Report No.: W7L-P22090015-1RF05

RELEASE CONTROL RECORD

ISSUE NO.	REASON FOR CHANGE	DATE ISSUED
W7L-P21100018-4RF05	Original release	Dec. 17, 2021
W7L-P22090015-1RF05	Based on the original product changing the packaging factory of the chip and software version, removed Aohai_A829US adapter, BRL_CB - 36A USB cable, Saibao_CB - 12A USB cable, LEADER_HS-34 earphone, added Saibao_AC-2A USB cable. The new sample verify Power and RSE worst case (GSM 1900), other test data is copied from the original test report W7L-P21100018-4RF05.	Oct. 10, 2022

1 SUMMARY OF TEST RESULTS

The EUT has been tested according to the following specifications:

APPLIED STANDARD: FCC Part 24 & Part 2		
STANDARD SECTION	TEST TYPE	RESULT
§2.1046	Conducted Output Power	Compliance
§24.232	Equivalent Isotropic Radiated Power	Compliance
§2.1055 §24.235	Frequency Stability	Compliance
§2.1049 §24.238(b)	Occupied Bandwidth	Compliance
§24.232(d)	Peak to average ratio	Compliance
§24.238(b)	Band Edge Measurements	Compliance
§2.1051 §24.238	Conducted Spurious Emissions	Compliance
§2.1053 §24.238	Radiated Spurious Emissions	Compliance

Note: Except the data of RSE and power, other data please refer to APPENDIX.

1.1 MEASUREMENT UNCERTAINTY

Where relevant, the following measurement uncertainty levels have been estimated for tests performed on the EUT as specified in CISPR 16-4-2:

MEASUREMENT	UNCERTAINTY
Frequency Stability	± 76.97Hz
Radiated emissions & Radiated Power (30MHz~1GMHz)	±4.98dB
Radiated emissions & Radiated Power (1GMHz ~6GMHz)	±4.70dB
Radiated emissions (6GMHz ~18GMHz)	±4.60dB
Radiated emissions (18GMHz ~40GMHz)	±4.12dB
Conducted emissions	±4.01dB
Occupied Channel Bandwidth	±43.58KHz
Conducted Output power	±2.06dB
Band Edge Measurements	±4.70dB
Peak to average ratio	±0.76dB

This uncertainty represents an expanded uncertainty expressed at approximately the 95% confidence level using a coverage factor of k=2.



1.2 TEST SITE AND INSTRUMENTS

Equipment	Manufacturer	Model No.	Serial No.	Last Cal.	Next Cal.
MXE EMI Receiver	KEYSIGHT	N9038A-544	MY54450026	Apr. 22,21	Apr. 21,22
MXE EMI Receiver	KEYSIGHT	N9038A-544	MY54450026	Apr. 21,22	Apr. 20,23
EXA Signal Analyzer	KEYSIGHT	N9010A-544	MY54510355	Jun. 03,21	Jun. 02,22
EXA Signal Analyzer	KEYSIGHT	N9010A-544	MY54510355	Jun. 02,22	Jun. 01,23
Bilog Antenna 2	ETS-LINDGREN	3143B	00161965	Mar. 05,21	Mar. 04,22
Bilog Antenna 2	ETS-LINDGREN	3143B	00161965	Mar. 04,22	Mar. 03,23
Horn Antenna 1	ETS-LINDGREN	3117	00168728	Aug. 19,21	Aug. 18,22
Horn Antenna 1	ETS-LINDGREN	3117	00168728	Aug. 18,22	Aug. 17,23
Horn Antenna 2	ETS-LINDGREN	3117	00168692	Apr. 02,21	Apr. 01,22
Horn Antenna 2	ETS-LINDGREN	3117	00168692	Apr. 01,22	Mar. 31,23
Horn Antenna (18GHz-40GHz)	N/A	QWH-SL-18-40-K-SG/QMS-00361	15433	Aug. 25, 21	Aug. 24, 22
Horn Antenna (18GHz-40GHz)	N/A	QWH-SL-18-40-K-SG/QMS-00361	15433	Aug. 24, 22	Aug. 23, 23
Radio Communication Analyzer	ANRITSU	MT8820C	6201465426	Feb. 25,21	Feb. 24,22
Radio Communication Analyzer	ANRITSU	MT8820C	6201465426	Feb. 24,22	Feb. 23,23
Signal Pre-Amplifier	EMSI	EMC 9135	980249	Jun. 02,21	Jun. 01,22
Signal Pre-Amplifier	EMSI	EMC 9135	980249	Jun. 01,22	May. 31,23
Signal Pre-Amplifier	EMSI	EMC 012645B	980257	Jun. 03,21	Jun. 02,22
Signal Pre-Amplifier	EMSI	EMC 012645B	980257	Jun. 02,22	Jun. 01,23
Signal Pre-Amplifier	EMSI	EMC 184045B	980259	Apr. 22,21	Apr. 21,22
Signal Pre-Amplifier	EMSI	EMC 184045B	980259	Apr. 21,22	Apr. 20,23
3m Semi-anechoic Chamber	ETS-LINDGREN	9m*6m*6m	Euroshieldpn-CT0001143-1216	May. 19,20	May. 18,23
Test Software	E3	V 9.160323	N/A	N/A	N/A
Test Software	ADT	ADT_Radiated_V 7.6.15.9.2	N/A	N/A	N/A
10dB Attenuator	JFW/USA	50HF-010-SMA	1505	Jun. 03,21	Jun. 02,22
10dB Attenuator	JFW/USA	50HF-010-SMA	1505	Jun. 02,22	Jun. 01,23
Power Meter	Anritsu	ML2495A	1506002	Apr. 07,21	Apr. 06,22
Power Meter	Anritsu	ML2495A	1506002	Apr. 06,22	Apr. 05,23
Power Sensor	Anritsu	MA2411B	1339352	May. 07,21	May. 06,22
Power Sensor	Anritsu	MA2411B	1339352	May. 06,22	May. 05,23
Temperature Chamber	ESPEC	SH-242	93000855	Jun. 02,21	Jun. 01,22
Temperature Chamber	ESPEC	SH-242	93000855	Jun. 01,22	May. 31,23
MXG Analog Microvave Signal Generator	KEYSIGHT	N5183A	MY50143024	Mar. 05,21	Mar. 04,22
MXG Analog Microvave	KEYSIGHT	N5183A	MY50143024	Mar. 04,22	Mar. 03,23



**BUREAU
VERITAS**

Test Report No.: W7L-P22090015-1RF05

Signal Generator					
Power Divider	MCLI/USA	PS2-15	24880	N/A	N/A

- NOTE:**
1. The calibration interval of the above test instruments is 12 months or 36 months and the calibrations are traceable to CEPREI/CHINA, GRGT/CHINA and NIM/CHINA.
 2. The test was performed in 3m Semi-anechoic Chamber and RF Oven Room.
 3. The horn antenna is used only for the measurement of emission frequency above 1GHz if tested.
 4. The FCC Site Registration No. is 525120; The Designation No. is CN1171.



2 GENERAL INFORMATION

2.1 GENERAL DESCRIPTION OF EUT

PRODUCT	Multi-band GSM/WCDMA/LTE phone with Bluetooth&WLAN	
BRAND NAME	NOKIA	
MODEL NAME	TA-1401	
NOMINAL VOLTAGE	5.0Vdc(adapter or host equipment) 3.85Vdc (Li-ion, battery)	
MODULATION TYPE	GSM/GPRS: GMSK EDGE: 8PSK	
FREQUENCY RANGE	GSM/GPRS/EDGE	1850.2MHz ~ 1909.8MHz
MAX. EIRP POWER	GSM/GPRS	1091.44mW
	EDGE	520.00mW
EMISSION DESIGNATOR	GSM/GPRS	243KGXW
	EDGE	252KG7W
ANTENNA TYPE	Fixed Internal Antenna with 0.9dBi gain for GSM1900	
HW VERSION	19655-1-11M12	
SW VERSION	00WW_1_520	
I/O PORTS	Refer to user's manual	
CABLE SUPPLIED	USB1 cable: unshielded without ferrite, 1.0meter USB2 cable: unshielded without ferrite, 1.0meter Earphone1: non-shielded cable, with w/o ferrite core, 1.2 meter	
EXTREME TEMPERATURE	0-40 °C	
EXTREME VOLTAGE	3.5V - 4.4V	

NOTE:

- For a more detailed features description, please refer to the manufacturer's specifications or the user's manual.
- The EUT incorporates a SISO function. Physically, the EUT provides one completed transmitter and one receiver.

MODULATION MODE	TX FUNCTION
GSM/GPRS/EDGE	1TX/1RX

- For the test results, the EUT had been tested with all conditions. But only the worst case was shown in test report.



**BUREAU
VERITAS**

Test Report No.: W7L-P22090015-1RF05

List of Accessory:

ACCESSORIES	BRAND	MANUFACTURER	MODEL	SPECIFICATION
Battery	Nokia	Hunan Gaoyuan Battery Co., Ltd.	WT341	Capacity: 3.85 Vdc, 4900mAh
AC Adapter 1	Nokia	ShenZhenBaiJunDa ElectronicCO.,LTD.	AD-010U	I/P: 100-240Vac, 0.35A, O/P: 5.0Vdc, 2.0A
AC Adapter 2	Nokia	SHENZHEN TIANYIN ELECTRONICS CO., LTD.	CH-21U	I/P: 100-240Vac, 0.3A, O/P: 5.0Vdc, 2.0A
AC Adapter 3	Nokia	YuTong Electronics(HuiZhou) Co.,Ltd	PA-US5V2A-036	I/P: 100-240Vac, 0.5A, O/P: 5.0Vdc, 2.0A
Earphone 1	Nokia	Guangdong Wivtak Technology Co., Ltd.	HS-34	Signal Line, 1.2meter
USB Cable 1	Nokia	HUIZHOU WASHIN ELECTRONICS CO.,LTD	CB-36A	Signal Line, 1.0meter
USB Cable 2	Nokia	Saibao(Jiangi) Communication Industial Co.,Ltd	AC-2A	Signal Line, 1.0meter



2.2 CONFIGURATION OF SYSTEM UNDER TEST

FOR RADIATION EMISSION TEST

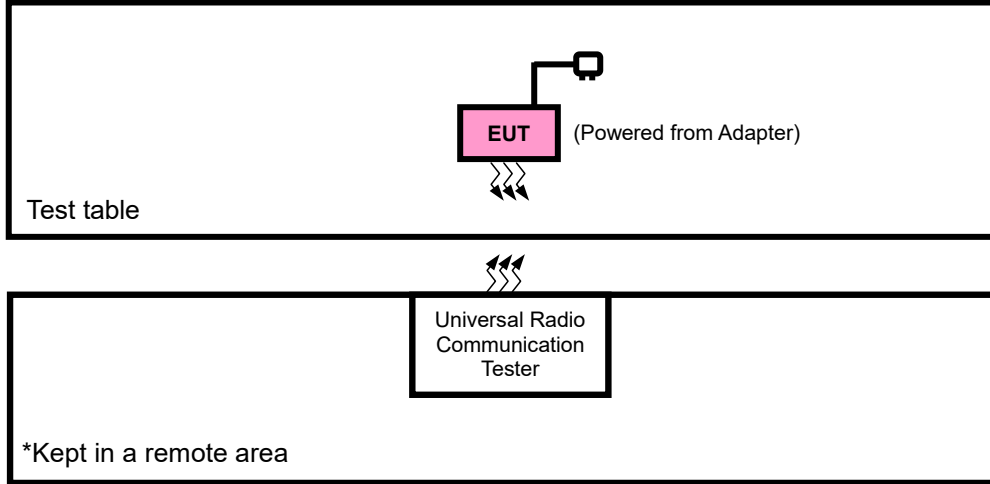



2.3 DESCRIPTION OF SUPPORT UNITS

The EUT has been tested as an independent unit together with other necessary accessories or support units. The following support units or accessories were used to form a representative test configuration during the tests.

NO.	PRODUCT	BRAND	MODEL NO.	SERIAL NO.	FCC ID
1	DC source	Kikusui/JP	PMX18-5A	0000001	N/A

NO.	SIGNAL CABLE DESCRIPTION OF THE ABOVE SUPPORT UNITS
1	DC Line: Unshielded, Detachable 1.0m

2.4 TEST ITEM AND TEST CONFIGURATION

Pre-Scan has been conducted to determine the worst-case mode from all possible combinations between available modulations, data rates, XYZ axis and antenna ports. The worst case in EIRP and radiated emission was found when positioned on X-plane for GSM/EDGE. Following channel(s) was (were) selected for the final test as listed below:

EUT CONFIGURE MODE	DESCRIPTION
A	EUT + Adapter with GSM

GSM MODE

EUT CONFIGURE MODE	TEST ITEM	AVAILABLE CHANNEL	TESTED CHANNEL	MODE
A	EIRP	512 to 810	512, 661, 810	GSM, EDGE
A	FREQUENCY STABILITY	512 to 810	512, 661, 810	GSM, EDGE
A	OCCUPIED BANDWIDTH	512 to 810	512, 661, 810	GSM, EDGE
A	PEAK TO AVERAGE RATIO	512 to 810	512, 661, 810	GSM, EDGE
A	BAND EDGE	512 to 810	512, 810	GSM, EDGE
A	CONDUCTED EMISSION	512 to 810	512, 661, 810	GSM, EDGE
A	RADIATED EMISSION	512 to 810	512, 661, 810	GSM, EDGE



TEST CONDITION:

TEST ITEM	ENVIRONMENTAL CONDITIONS	INPUT POWER	TESTED BY
EIRP	25deg. C, 57%RH	DC 5V By Adapter	Jace Hu
FREQUENCY STABILITY	23deg. C, 61%RH	3.85V By Battery	James Fu
OCCUPIED BANDWIDTH	23deg. C, 61%RH	DC5V By Adapter	James Fu
PEAK TO AVERAGE RATIO	23deg. C, 61%RH	DC 5V By Adapter	James Fu
BAND EDGE	23deg. C, 61%RH	DC5V By Adapter	James Fu
CONDCUDED EMISSION	23deg. C, 61%RH	DC5V By Adapter	James Fu
RADIATED EMISSION	23deg. C, 70%RH	DC5V By Adapter	Jace Hu

2.5 EUT OPERATING CONDITIONS

The EUT makes a call to the communication simulator. The communication simulator station system controlled a EUT to export maximum output power under transmission mode and specific channel frequency

2.6 GENERAL DESCRIPTION OF APPLIED STANDARDS

The EUT is a RF product. According to the specifications of the manufacturer, it must comply with the requirements of the following standards:

FCC 47 CFR Part 2

FCC 47 CFR Part 24

KDB 971168 D01 Power Meas License Digital Systems v03r01

ANSI/TIA/EIA-603-D

ANSI/TIA/EIA-603-E

ANSI C63.26-2015

NOTE: All test items have been performed and recorded as per the above standards.



3 TEST TYPES AND RESULTS

3.1 OUTPUT POWER MEASUREMENT

3.1.1 LIMITS OF OUTPUT POWER MEASUREMENT

Mobile and portable stations are limited to 2 watts EIRP.

3.1.2 TEST PROCEDURES

EIRP MEASUREMENT:

Per KDB 971168 D01 Power Meas License Digital Systems v03r01 or subclause 5.2.5.5 of ANSI C63.26-2015, the relevant equation for determining the ERP or EIRP from the conducted RF output power measured using the guidance provided above is:

$$\text{ERP or EIRP} = P_{\text{Meas}} + G_{\text{T}} - L_{\text{C}}$$

Where:

ERP or EIRP = effective radiated power or equivalent isotropically radiated power, respectively

(expressed in the same units as P_{Meas} , typically dBW or dBm);

P_{Meas} = measured transmitter output power or PSD, in dBm or dBW;

G_{T} = gain of the transmitting antenna, in dBd (ERP) or dBi (EIRP);

L_{C} = signal attenuation in the connecting cable between the transmitter and antenna, in dB.

CONDUCTED POWER MEASUREMENT:

The EUT was set up for the maximum power with WCDMA link data modulation and link up with simulator. Set the EUT to transmit under low, middle and high channel and record the power level shown on simulator.



3.1.3 TEST SETUP

EIRP / ERP Measurement:

CONDUCTED POWER MEASUREMENT:

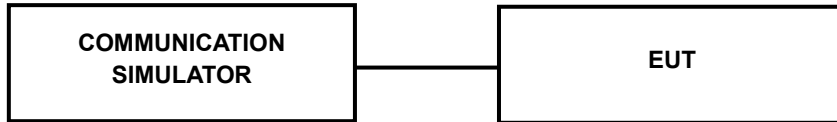

3.1.4 TEST RESULTS

CONDUCTED OUTPUT POWER (dBm)

Band	GSM1900		
	512	661	810
Channel	1850.2	1880	1909.8
Frequency	1850.2	1880	1909.8
GSM (GMSK, 1Tx-slot)	29.47	29.40	29.30
GPRS (GMSK, 1Tx-slot)	29.48	29.41	29.31
GPRS (GMSK, 2Tx-slot)	27.65	27.51	27.42
GPRS (GMSK, 3Tx-slot)	25.57	25.44	25.32
GPRS (GMSK, 4Tx-slot)	23.39	23.28	23.15
EDGE (8PSK, 1Tx-slot)	26.26	26.03	25.96
EDGE (8PSK, 2Tx-slot)	26.04	25.87	25.73
EDGE (8PSK, 3Tx-slot)	23.45	23.33	23.46
EDGE (8PSK, 4Tx-slot)	21.32	21.44	21.40



**BUREAU
VERITAS**

Test Report No.: W7L-P22090015-1RF05

EIRP POWER (dBm)

GSM

Channel	Frequency (MHz)	Conducted Power (dBm)	G _{T-Lc} (dB)	EIRP (dBm)	EIRP (mW)	Limit (W)
512	1850.2	29.48	0.9	30.38	1091.44	2
661	1880.0	29.41	0.9	30.31	1073.99	2
810	1909.8	29.31	0.9	30.21	1049.54	2

EDGE

Channel	Frequency (MHz)	Conducted Power (dBm)	G _{T-Lc} (dB)	EIRP (dBm)	EIRP (mW)	Limit (W)
512	1850.2	26.26	0.9	27.16	520.00	2
661	1880.0	26.03	0.9	26.93	493.17	2
810	1909.8	25.96	0.9	26.86	485.29	2



3.2 FREQUENCY STABILITY MEASUREMENT

3.2.1 LIMITS OF FREQUENCY STABILITY MEASUREMENT

The frequency stability shall be sufficient to ensure that the fundamental emission stays within the authorized frequency block.

3.2.2 TEST PROCEDURE

- a. Device is placed at the oven room. The oven room could control the temperatures and humidity. Power warm up is at least 15 min and power applied should perform before recording frequency error.
- b. EUT is connected the external power supply to control the DC input power. The test voltage range is from minimum to maximum working voltage. Each step shall be record the frequency error rate.
- c. The temperature range step is 10 degrees in this test items. All temperature levels shall be hold the $\pm 0.5^{\circ}\text{C}$ during the measurement testing. The each temperature step shall be at least 0.5 hours, consider the EUT could be test under the stability condition.

NOTE: The frequency error was recorded frequency error from the communication simulator.

3.2.3 TEST SETUP

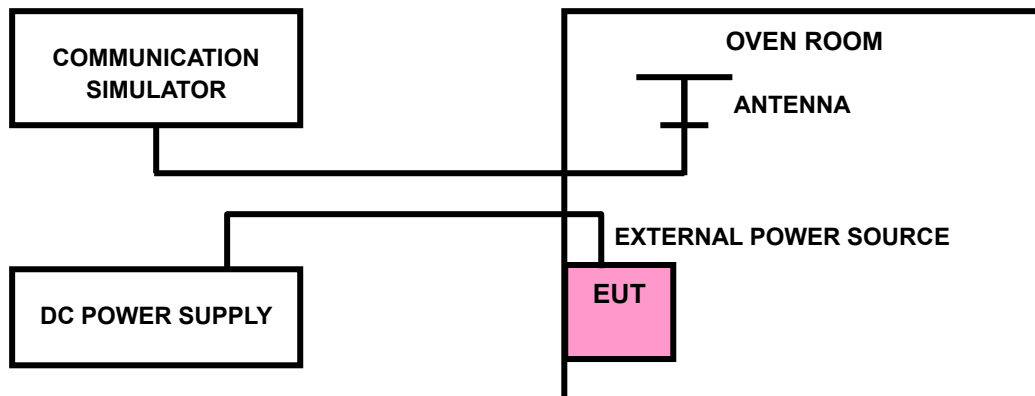



**BUREAU
VERITAS**

Test Report No.: W7L-P22090015-1RF05

3.2.4 TEST RESULTS

Please Refer to Appendix Of this test report.



3.3 OCCUPIED BANDWIDTH MEASUREMENT

3.3.1 TEST PROCEDURES

The EUT makes a call to the communication simulator. All measurements were done at low, middle and high operational frequency range. The communication simulator station system controlled a EUT to export maximum output power under transmission mode and specific channel frequency. Use OBW measurement function of Spectrum analyzer to measure 99 % occupied bandwidth.

3.3.2 TEST SETUP

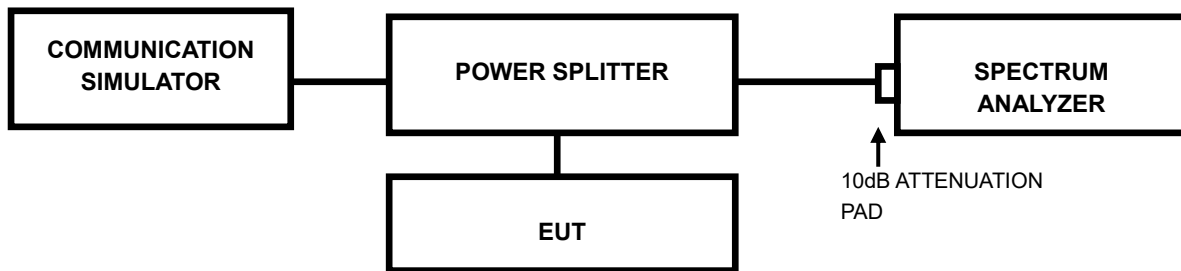

3.3.3 TEST PROCEDURES

- The conducted occupied bandwidth used the power splitter via EUT RF power connector between simulation base station and spectrum analyzer.
- Use OBW measurement function of Spectrum analyzer to measure 99 % occupied bandwidth.



Test Report No.: W7L-P22090015-1RF05

3.3.4 TEST RESULTS

Please Refer to Appendix Of this test report.



3.4 BAND EDGE MEASUREMENTC

3.4.1 LIMITS OF BAND EDGE MEASUREMENT

Power of any emission outside of the authorized operating frequency ranges must be attenuated below the transmitting power (P) by a factor of at least $43 + 10 \log(P)$ dB. In the 1 MHz bands immediately outside and adjacent to the frequency block a resolution bandwidth of at least one percent of the emission bandwidth of the fundamental emission of the transmitter may be employed.

3.4.2 TEST SETUP

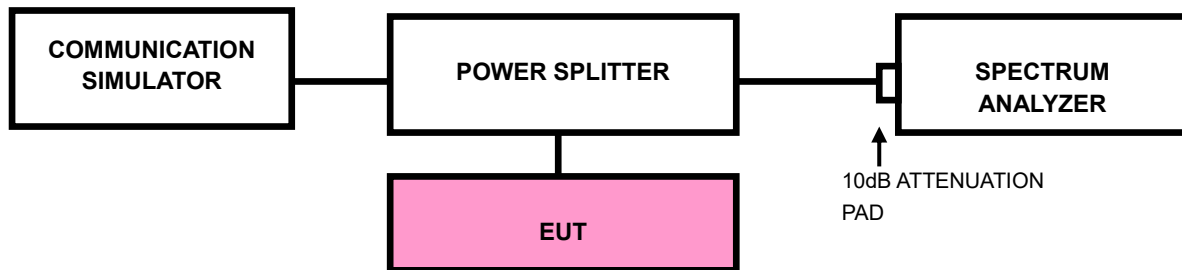



Test Report No.: W7L-P22090015-1RF05

3.4.3 TEST PROCEDURES

- a. All measurements were done at low and high operational frequency range.
- b. The center frequency of spectrum is the band edge frequency and span is 1.5 MHz. RBW of the spectrum is 10kHz and VBW of the spectrum is 30kHz (GSM/GPRS/EDGE).
- c. Record the max trace plot into the test report.



**BUREAU
VERITAS**

Test Report No.: W7L-P22090015-1RF05

3.4.4. TEST RESULTS

Please Refer to Appendix Of this test report.



3.5 CONDUCTED SPURIOUS EMISSIONS

3.5.1 LIMITS OF CONDUCTED SPURIOUS EMISSIONS MEASUREMENT

The power of any emission outside of the authorized operating frequency ranges must be attenuated below the transmitting power (P) by a factor of at least $43 + 10 \log(P)$ dB. The emission limit equal to -13dBm .

3.5.2 TEST PROCEDURE

- a. The EUT makes a phone call to the communication simulator. All measurements were done at low, middle and high operational frequency range.
- b. Measuring frequency range is from 30 MHz to 19.1GHz. 10dB attenuation pad is connected with spectrum. RBW=1MHz and VBW=3MHz is used for conducted emission measurement.

3.5.3 TEST SETUP

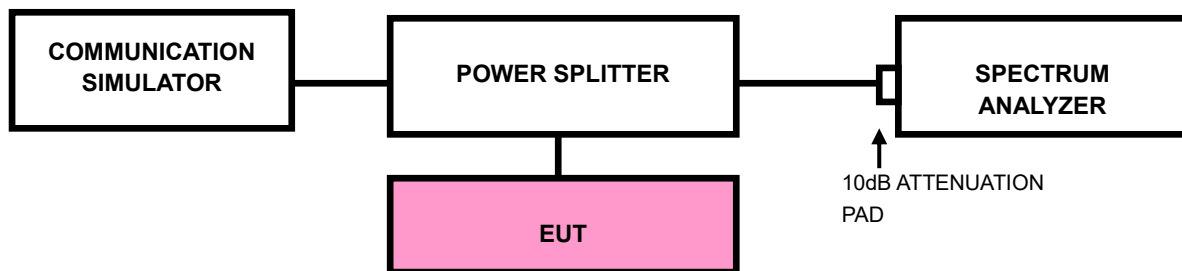



**BUREAU
VERITAS**

Test Report No.: W7L-P22090015-1RF05

3.5.4 TEST RESULTS

Please Refer to Appendix Of this test report.



3.6 RADIATED EMISSION MEASUREMENT

3.6.1 LIMITS OF RADIATED EMISSION MEASUREMENT

The power of any emission outside of the authorized operating frequency ranges must be attenuated below the transmitting power (P) by a factor of at least $43 + 10 \log(P)$ dB. The emission limit equal to -13dBm .

3.6.2 TEST PROCEDURES

- a. Substitution method is used for E.I.R.P measurement. In the semi-anechoic chamber, EUT placed on the 0.8m height of Turn Table, rotated the table around 360 degrees to search the maximum radiation power and receiver antenna shall be rotated vertical and horizontal polarization and moved height from 1m to 4m to find the maximum polar radiated power. The "Read Value" is the spectrum reading the maximum power value.
- b. The substitution horn antenna is substituted for EUT at the same position and signals generator export the CW signal to the substitution antenna via a TX cable. Rotated the Turn Table and moved receiving antenna to find the maximum radiation power. Adjust output power level of S.G to get a Value of spectrum reading equal to "Read Value" of step a. Record the power level of S.G
- c. $\text{EIRP} = \text{Output power level of S.G} - \text{TX cable loss} + \text{Antenna gain of substitution horn}$.

NOTE: The resolution bandwidth and video bandwidth of test receiver/spectrum analyzer is 1MHz/3MHz.

3.6.3 DEVIATION FROM TEST STANDARD

No deviation



3.6.4 TEST SETUP

< Frequency Range below 30MHz >

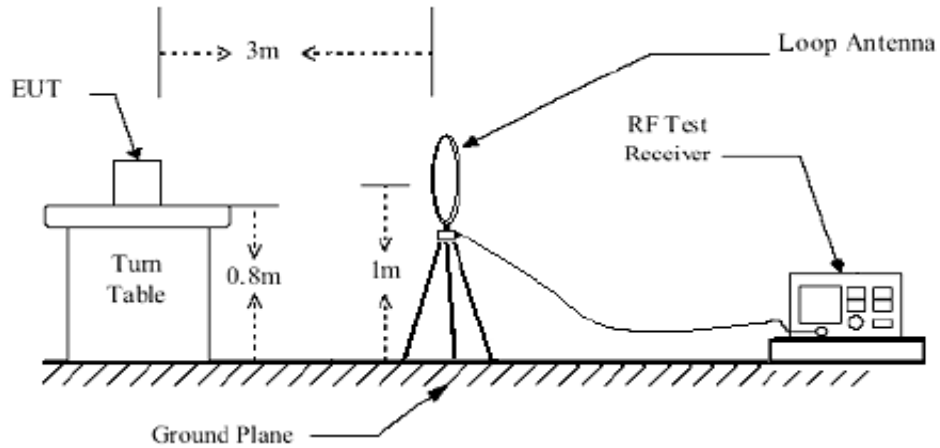

< Frequency Range 30MHz~1GHz >

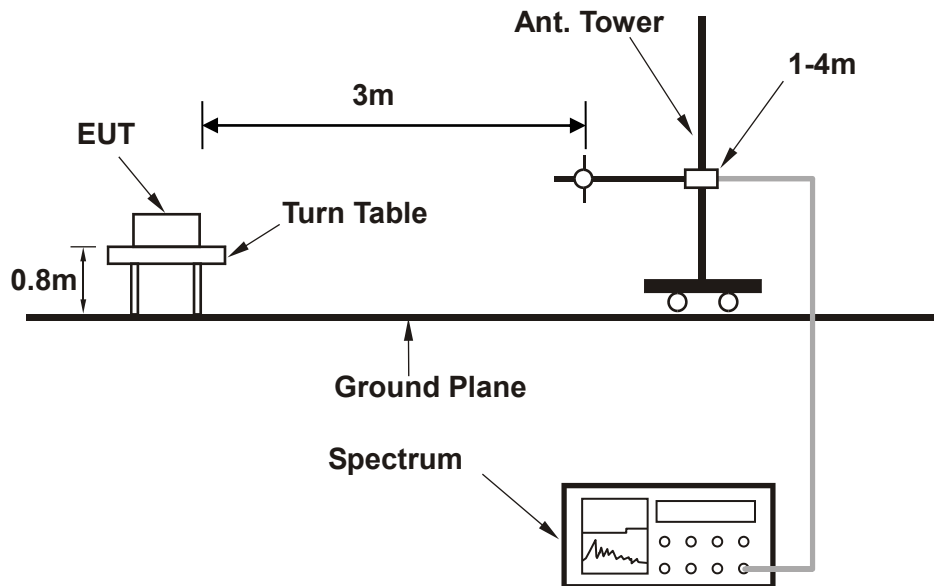

<Frequency Range above 1GHz>

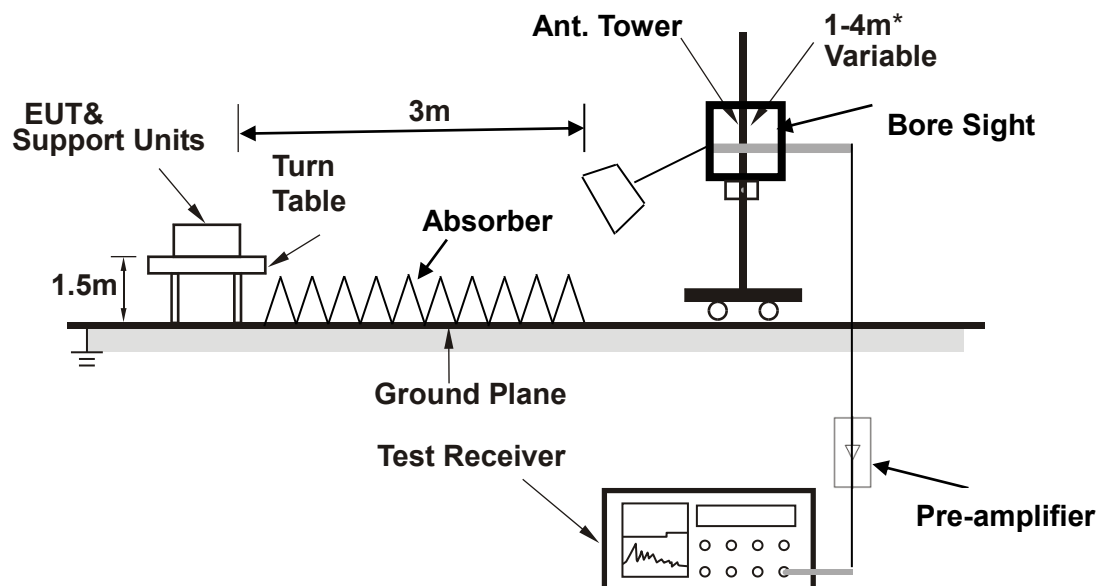

Note: Above 1G is a directional antenna

Depends on the EUT height and the antenna 3dB beamwidth both, refer to section 7.3 of CISPR 16-2-3.

For the actual test configuration, please refer to the attached file (Test Setup Photo).



3.6.5 TEST RESULTS

NOTE : The 9K~30MHz amplitude of spurious emissions attenuated more than 20 dB below the permissible value is not required in the report.

BELOW 1GHz WORST-CASE DATA

30 MHz – 1GHz data:

GSM 1900

CHANNEL BANDWIDTH: channel 512~810

MODE	TX channel 661	FREQUENCY RANGE	Below 1000MHz
ENVIRONMENTAL CONDITIONS	23deg. C, 70%RH	INPUT POWER	AC 120V/60Hz
TESTED BY	Jace Hu		
ANTENNA POLARITY & TEST DISTANCE: HORIZONTAL AT 3 M			

	Freq	Level	Read Level	Limit Line	Over Limit	Factor	Remark	Pol/Phase	
	MHz	dBm/m	dBm	dBm/m	dB	dB/m			
1	PP	56.190	-54.05	-35.97	-13.00	-41.05	-18.08	Peak	Horizontal
2		89.170	-71.87	-50.88	-13.00	-58.87	-20.99	Peak	Horizontal
3		172.590	-60.48	-43.64	-13.00	-47.48	-16.84	Peak	Horizontal
4		276.380	-59.75	-47.76	-13.00	-46.75	-11.99	Peak	Horizontal
5		307.420	-60.95	-48.67	-13.00	-47.95	-12.28	Peak	Horizontal
6		377.260	-68.45	-57.87	-13.00	-55.45	-10.58	Peak	Horizontal

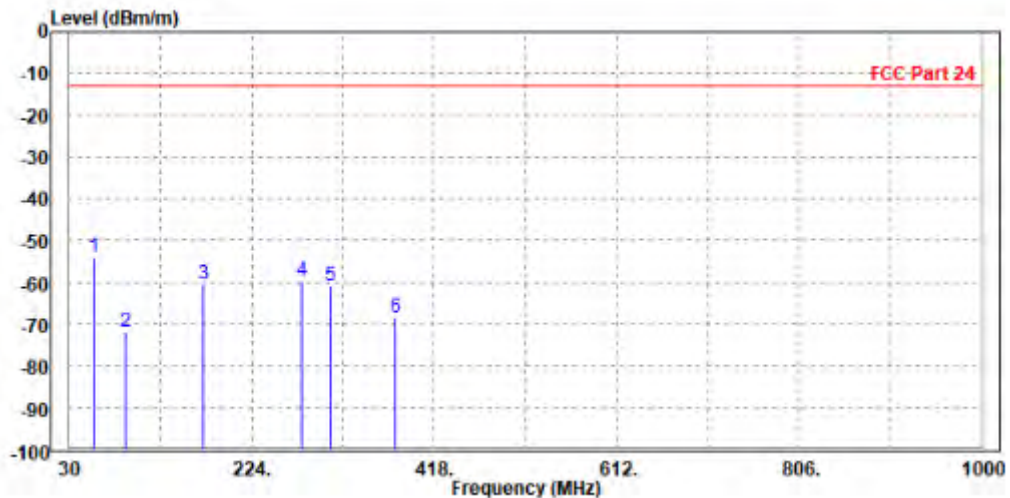



**BUREAU
VERITAS**

Test Report No.: W7L-P22090015-1RF05

MODE	TX channel 661	FREQUENCY RANGE	Below 1000MHz
ENVIRONMENTAL CONDITIONS	23deg. C, 70%RH	INPUT POWER	AC 120V/60Hz
TESTED BY	Jace Hu		
ANTENNA POLARITY & TEST DISTANCE: VERTICAL AT 3 M			

	Freq	Level	Read Level	Limit Line	Over Limit	Factor	Remark	Pol/Phase
	MHz	dBm/m	dBm	dBm/m	dB	dB/m		
1	30.970	-61.62	-44.29	-13.00	-48.62	-17.33	Peak	Vertical
2	55.220	-57.12	-32.79	-13.00	-44.12	-24.33	Peak	Vertical
3	100.810	-58.19	-51.49	-13.00	-45.19	-6.70	Peak	Vertical
4	164.830	-68.68	-51.47	-13.00	-55.68	-17.21	Peak	Vertical
5	208.480	-67.95	-50.68	-13.00	-54.95	-17.27	Peak	Vertical
6	309.360	-59.31	-48.66	-13.00	-46.31	-10.65	Peak	Vertical

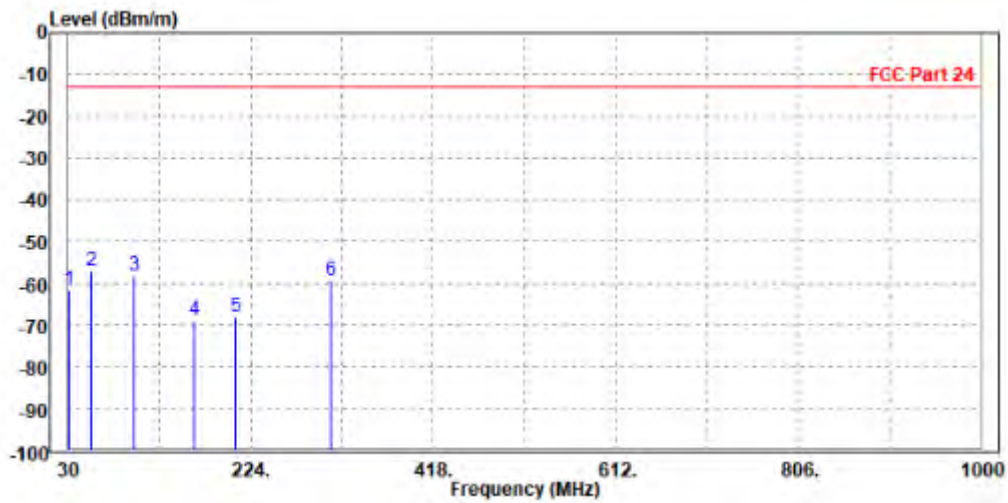



ABOVE 1GHz DATA

Note: For higher frequency, the emission is too low to be detected.

WORST-CASE DATA

GSM 1900

CH 512

MODE	TX channel 512	FREQUENCY RANGE	Above 1000MHz
ENVIRONMENTAL CONDITIONS	23deg. C, 70%RH	INPUT POWER	AC 120V/60Hz
TESTED BY	Jace Hu		
ANTENNA POLARITY & TEST DISTANCE: HORIZONTAL AT 3 M			

	Freq	Level	Read Level	Limit Line	Over Limit	Factor	Remark	Pol/Phase
	MHz	dBm/m	dBm	dBm/m	dB	dB/m		
1	3700.400	-49.59	-57.43	-13.00	-36.59	7.84	Peak	Horizontal
2 PP	5560.000	-39.33	-49.92	-13.00	-26.33	10.59	Peak	Horizontal

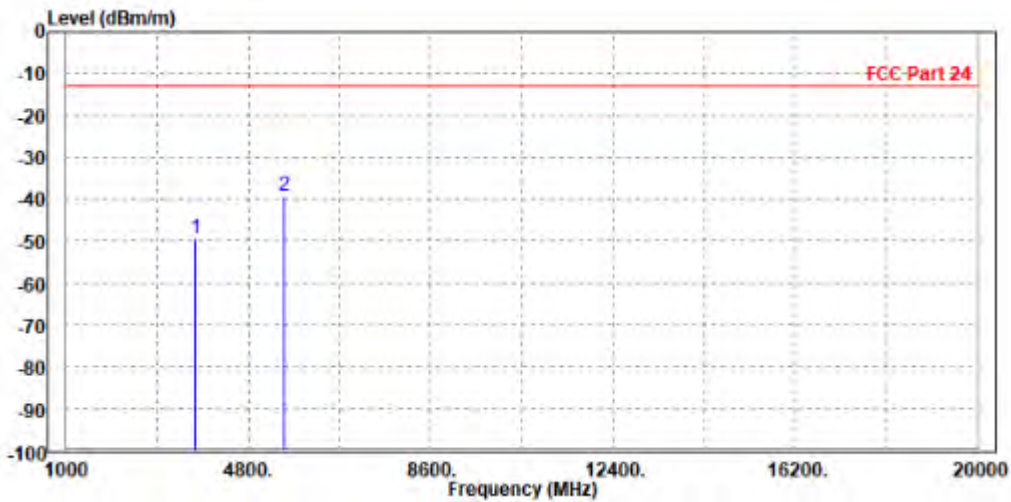



**BUREAU
VERITAS**

Test Report No.: W7L-P22090015-1RF05

MODE	TX channel 512	FREQUENCY RANGE	Above 1000MHz
ENVIRONMENTAL CONDITIONS	23deg. C, 70%RH	INPUT POWER	AC 120V/60Hz
TESTED BY	Jace Hu		
ANTENNA POLARITY & TEST DISTANCE: VERTICAL AT 3 M			

	Freq	Level	Read Level	Limit Line	Over Limit	Factor	Remark	Pol/Phase
	MHz	dBm/m	dBm	dBm/m	dB	dB/m		
1	3698.000	-50.13	-57.74	-13.00	-37.13	7.61	Peak	Vertical
2 PP	5550.600	-43.07	-53.94	-13.00	-30.07	10.87	Peak	Vertical

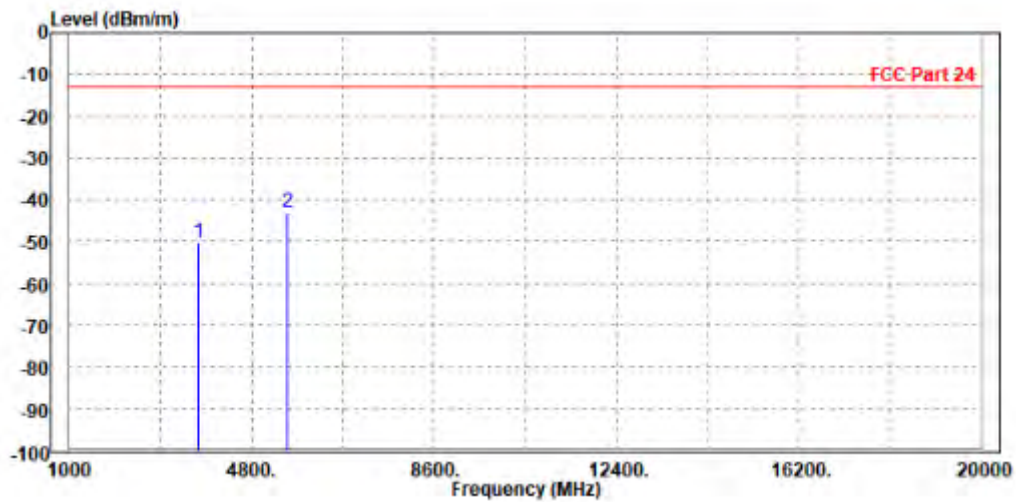



**BUREAU
VERITAS**

Test Report No.: W7L-P22090015-1RF05

CH 661

MODE	TX channel 661	FREQUENCY RANGE	Above 1000MHz
ENVIRONMENTAL CONDITIONS	23deg. C, 70%RH	INPUT POWER	AC 120V/60Hz
TESTED BY	Jace Hu		
ANTENNA POLARITY & TEST DISTANCE: HORIZONTAL AT 3 M			

	Freq	Level	Read Level	Limit Line	Over Limit	Factor	Remark	Pol/Phase
	MHz	dBm/m	dBm	dBm/m	dB	dB/m		
1	3755.000	-52.62	-60.60	-13.00	-39.62	7.98	Peak	Horizontal
2 PP	5640.000	-38.73	-49.47	-13.00	-25.73	10.74	Peak	Horizontal

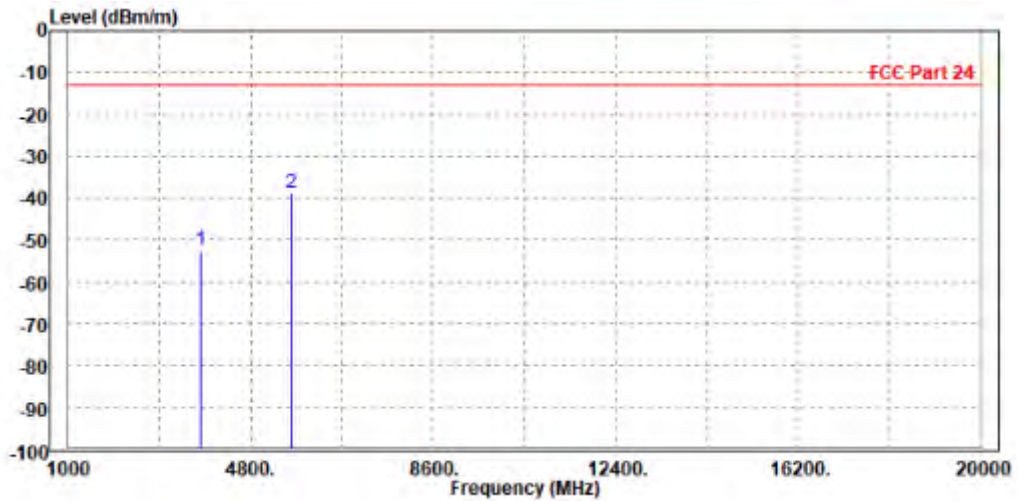



**BUREAU
VERITAS**

Test Report No.: W7L-P22090015-1RF05

MODE	TX channel 661	FREQUENCY RANGE	Above 1000MHz
ENVIRONMENTAL CONDITIONS	23deg. C, 70%RH	INPUT POWER	AC 120V/60Hz
TESTED BY	Jace Hu		
ANTENNA POLARITY & TEST DISTANCE: VERTICAL AT 3 M			

	Freq	Level	Read Level	Limit Line	Over Limit	Factor	Remark	Pol/Phase
	MHz	dBm/m	dBm	dBm/m	dB	dB/m		
1	3760.000	-50.04	-57.74	-13.00	-37.04	7.70	Peak	Vertical
2 PP	5636.000	-36.02	-47.14	-13.00	-23.02	11.12	Peak	Vertical

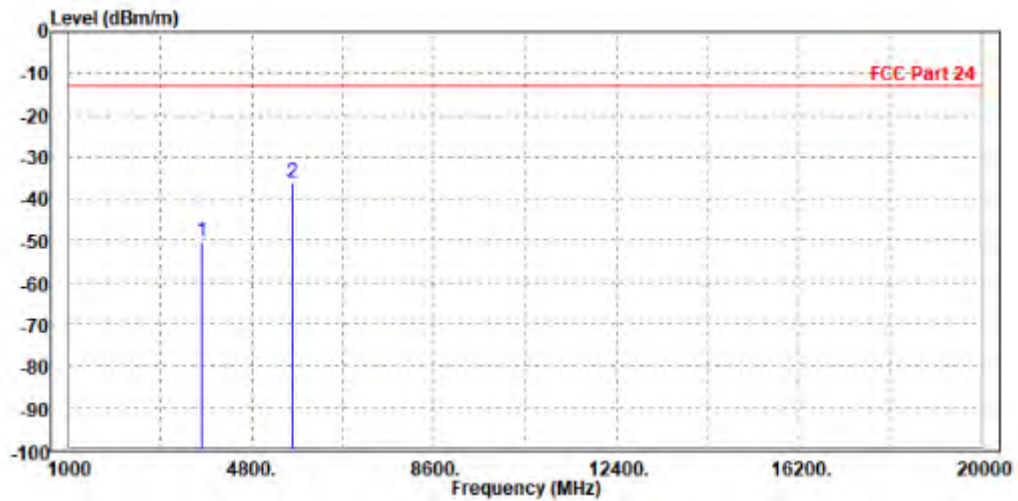



**BUREAU
VERITAS**

Test Report No.: W7L-P22090015-1RF05

CH 810

MODE	TX channel 810	FREQUENCY RANGE	Above 1000MHz
ENVIRONMENTAL CONDITIONS	23deg. C, 70%RH	INPUT POWER	AC 120V/60Hz
TESTED BY	Jace Hu		
ANTENNA POLARITY & TEST DISTANCE: HORIZONTAL AT 3 M			

	Freq	Level	Read Level	Limit Line	Over Limit	Factor	Remark	Pol/Phase
	MHz	dBm/m	dBm	dBm/m	dB	dB/m		
1	3812.000	-52.13	-60.25	-13.00	-39.13	8.12	Peak	Horizontal
2 PP	5729.400	-39.13	-50.04	-13.00	-26.13	10.91	Peak	Horizontal

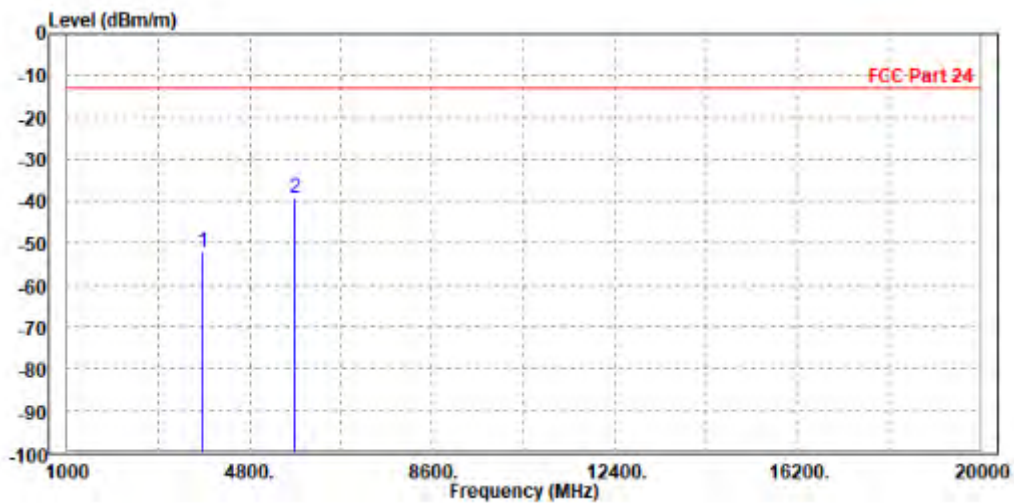



**BUREAU
VERITAS**

Test Report No.: W7L-P22090015-1RF05

MODE	TX channel 810	FREQUENCY RANGE	Above 1000MHz
ENVIRONMENTAL CONDITIONS	23deg. C, 70%RH	INPUT POWER	AC 120V/60Hz
TESTED BY	Jace Hu		
ANTENNA POLARITY & TEST DISTANCE: VERTICAL AT 3 M			

	Freq	Level	Read Level	Limit Line	Over Limit	Factor	Remark	Pol/Phase
	MHz	dBm/m	dBm	dBm/m	dB	dB/m		
1	3819.600	-50.96	-58.74	-13.00	-37.96	7.78	Peak	Vertical
2 PP	5731.000	-37.85	-49.24	-13.00	-24.85	11.39	Peak	Vertical

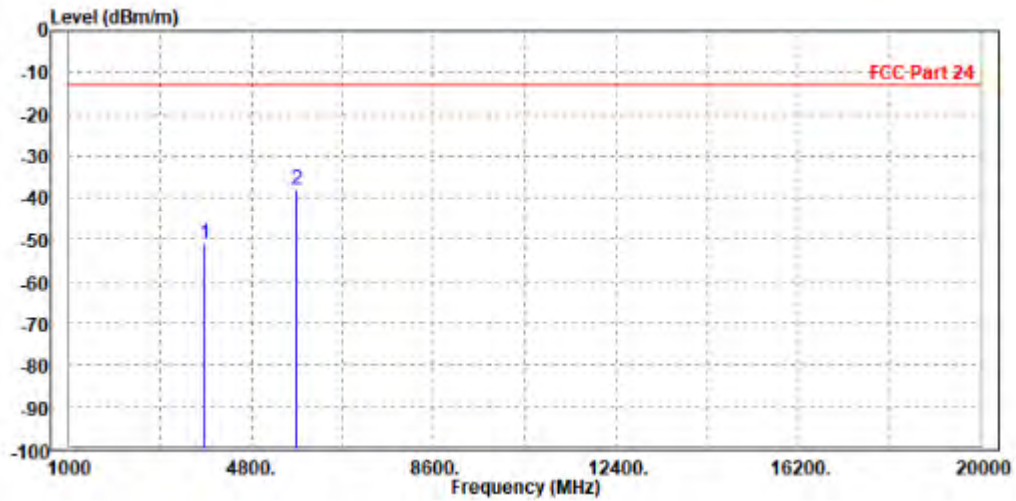



**BUREAU
VERITAS**

Test Report No.: W7L-P22090015-1RF05

EDGE 1900

CH 512

MODE	TX channel 512	FREQUENCY RANGE	Above 1000MHz
ENVIRONMENTAL CONDITIONS	23deg. C, 70%RH	INPUT POWER	AC 120V/60Hz
TESTED BY	Jace Hu		
ANTENNA POLARITY & TEST DISTANCE: HORIZONTAL AT 3 M			

	Freq	Level	Read Level	Limit Line	Over Limit	Factor	Remark	Pol/Phase
	MHz	dBm/m	dBm	dBm/m	dB	dB/m		
1	PP 3698.000	-47.73	-56.51	-13.00	-34.73	8.78	Peak	Horizontal
2	5550.600	-49.64	-59.83	-13.00	-36.64	10.19	Peak	Horizontal

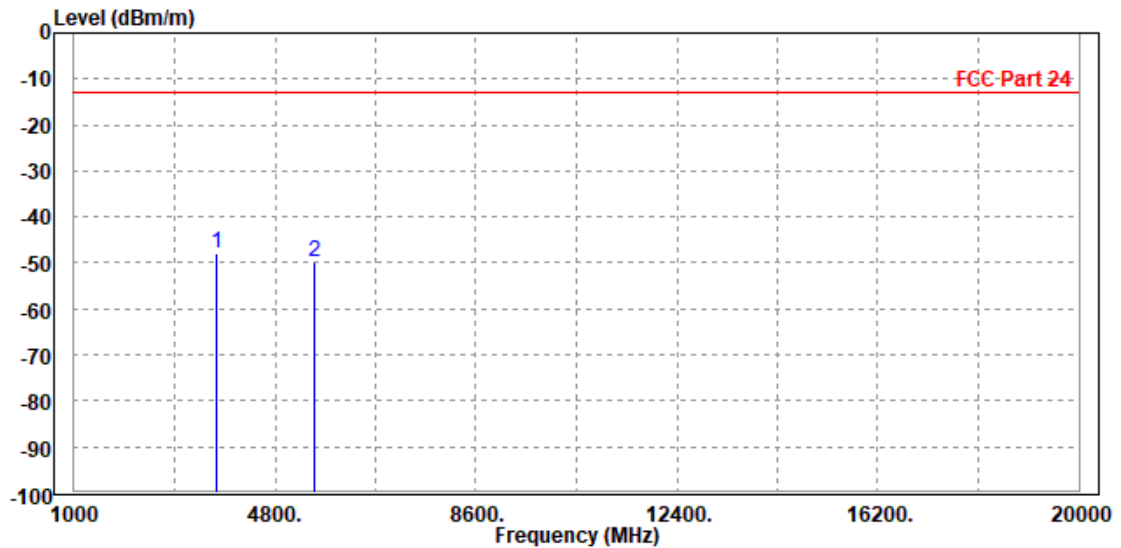



**BUREAU
VERITAS**

Test Report No.: W7L-P22090015-1RF05

MODE	TX channel 512	FREQUENCY RANGE	Above 1000MHz
ENVIRONMENTAL CONDITIONS	23deg. C, 70%RH	INPUT POWER	AC 120V/60Hz
TESTED BY	Jace Hu		
ANTENNA POLARITY & TEST DISTANCE: VERTICAL AT 3 M			

			Read	Limit	Over			
	Freq	Level	Level	Line	Limit	Factor	Remark	Pol/Phase
	MHz	dBm/m	dBm	dBm/m	dB	dB/m		
1	PP 3698.000	-48.90	-58.15	-13.00	-35.90	9.25	Peak	Vertical
2	5550.600	-49.89	-59.79	-13.00	-36.89	9.90	Peak	Vertical

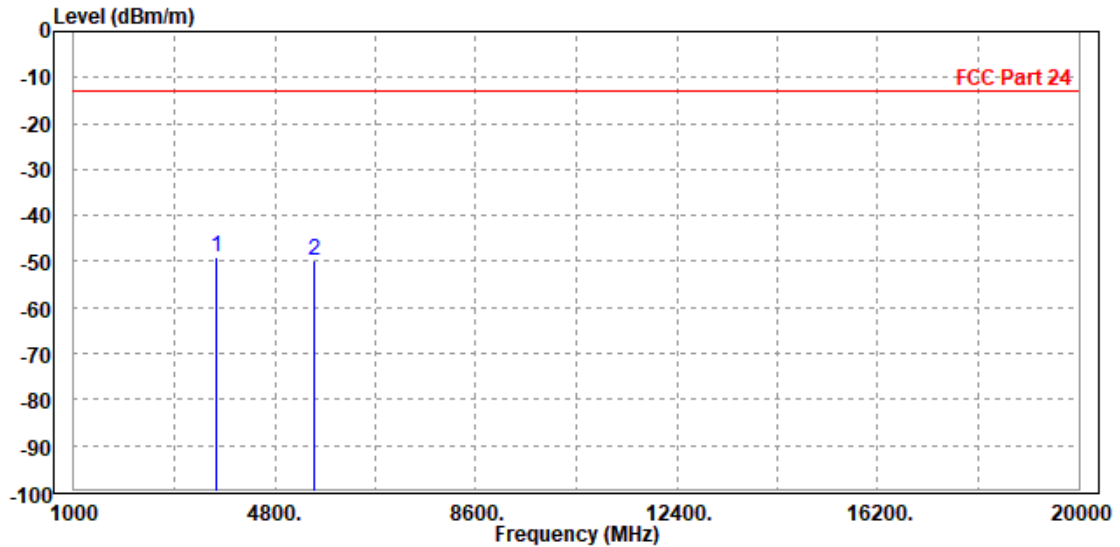



**BUREAU
VERITAS**

Test Report No.: W7L-P22090015-1RF05

CH 661

MODE	TX channel 661	FREQUENCY RANGE	Above 1000MHz
ENVIRONMENTAL CONDITIONS	23deg. C, 70%RH	INPUT POWER	AC 120V/60Hz
TESTED BY	Jace Hu		
ANTENNA POLARITY & TEST DISTANCE: HORIZONTAL AT 3 M			

	Freq	Level	Read Level	Limit Line	Over Limit	Factor	Remark	Pol/Phase
	MHz	dBm/m	dBm	dBm/m	dB	dB/m		
1	PP 3755.000	-47.03	-55.88	-13.00	-34.03	8.85	Peak	Horizontal
2	5640.000	-48.28	-58.76	-13.00	-35.28	10.48	Peak	Horizontal

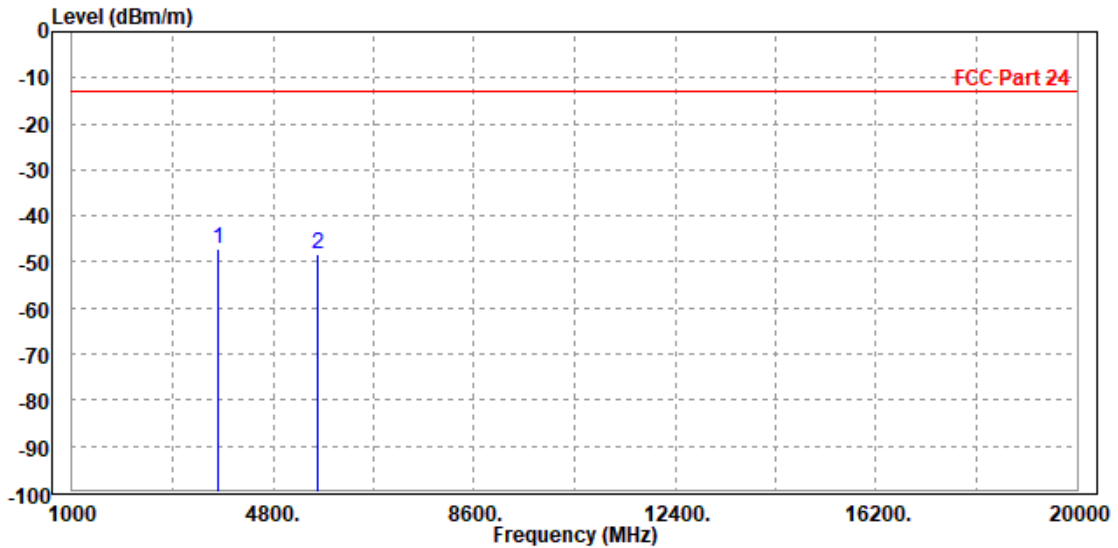



**BUREAU
VERITAS**

Test Report No.: W7L-P22090015-1RF05

MODE	TX channel 661	FREQUENCY RANGE	Above 1000MHz
ENVIRONMENTAL CONDITIONS	23deg. C, 70%RH	INPUT POWER	AC 120V/60Hz
TESTED BY	Jace Hu		
ANTENNA POLARITY & TEST DISTANCE: VERTICAL AT 3 M			

	Freq	Level	Read Level	Limit Line	Over Limit	Factor	Remark	Pol/Phase
	MHz	dBm/m	dBm	dBm/m	dB	dB/m		
1	PP 3755.000	-48.59	-57.86	-13.00	-35.59	9.27	Peak	Vertical
2	5640.000	-49.21	-59.46	-13.00	-36.21	10.25	Peak	Vertical

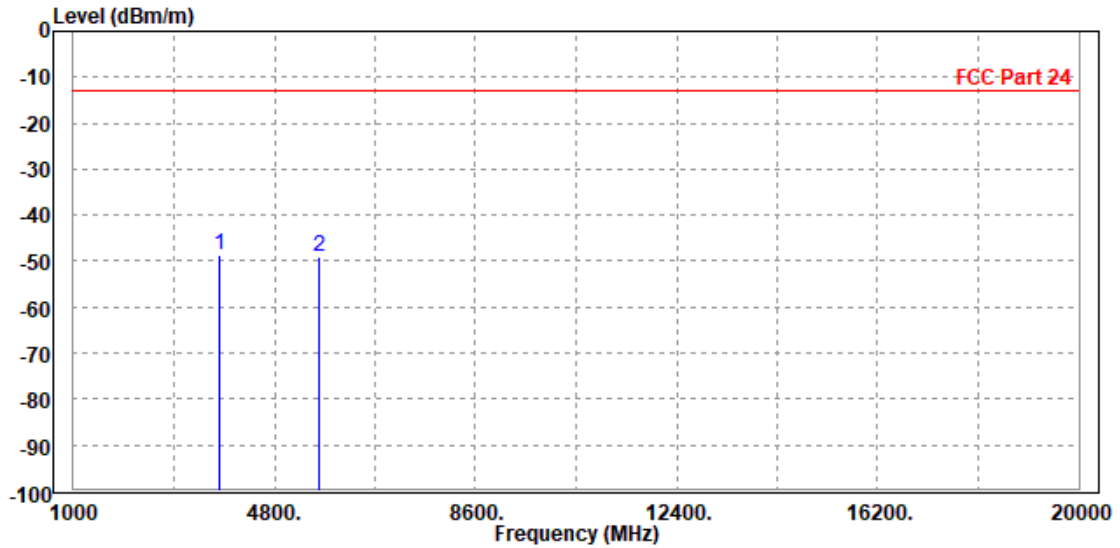



**BUREAU
VERITAS**

Test Report No.: W7L-P22090015-1RF05

CH 810

MODE	TX channel 810	FREQUENCY RANGE	Above 1000MHz
ENVIRONMENTAL CONDITIONS	23deg. C, 70%RH	INPUT POWER	AC 120V/60Hz
TESTED BY	Jace Hu		
ANTENNA POLARITY & TEST DISTANCE: HORIZONTAL AT 3 M			

	Freq	Level	Read Level	Limit Line	Over Limit	Factor	Remark	Pol/Phase
	MHz	dBm/m	dBm	dBm/m	dB	dB/m		
1	3819.600	-48.37	-57.28	-13.00	-35.37	8.91	Peak	Horizontal
2 PP	5729.400	-46.72	-57.50	-13.00	-33.72	10.78	Peak	Horizontal

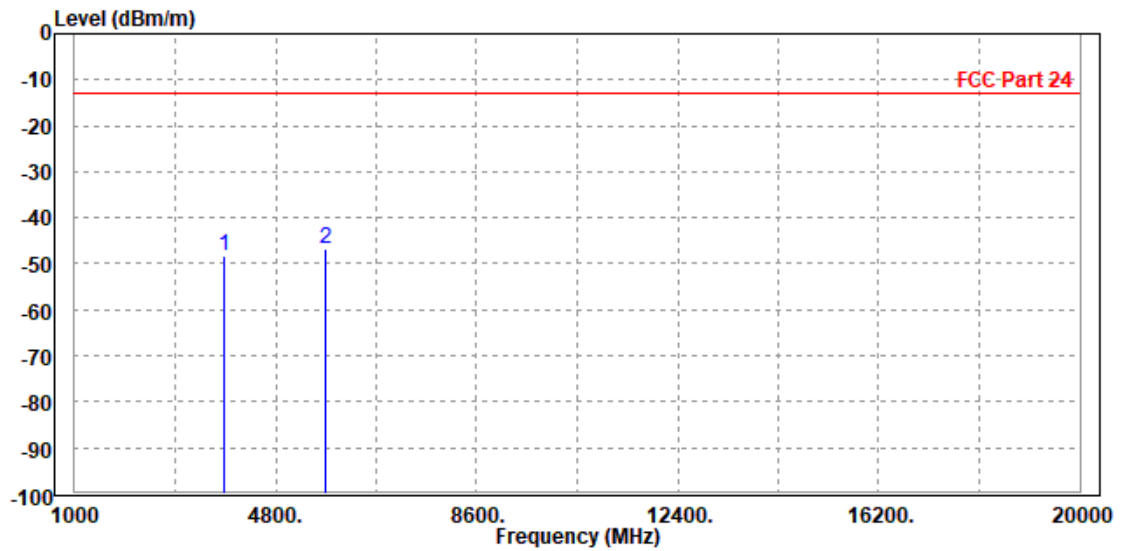



**BUREAU
VERITAS**

Test Report No.: W7L-P22090015-1RF05

MODE	TX channel 810	FREQUENCY RANGE	Above 1000MHz
ENVIRONMENTAL CONDITIONS	23deg. C, 70%RH	INPUT POWER	AC 120V/60Hz
TESTED BY	Jace Hu		
ANTENNA POLARITY & TEST DISTANCE: VERTICAL AT 3 M			

	Freq	Level	Read Level	Limit Line	Over Limit	Factor	Remark	Pol/Phase
	MHz	dBm/m	dBm	dBm/m	dB	dB/m		
1	3819.600	-48.24	-57.53	-13.00	-35.24	9.29	Peak	Vertical
2 PP	5729.400	-47.52	-58.11	-13.00	-34.52	10.59	Peak	Vertical

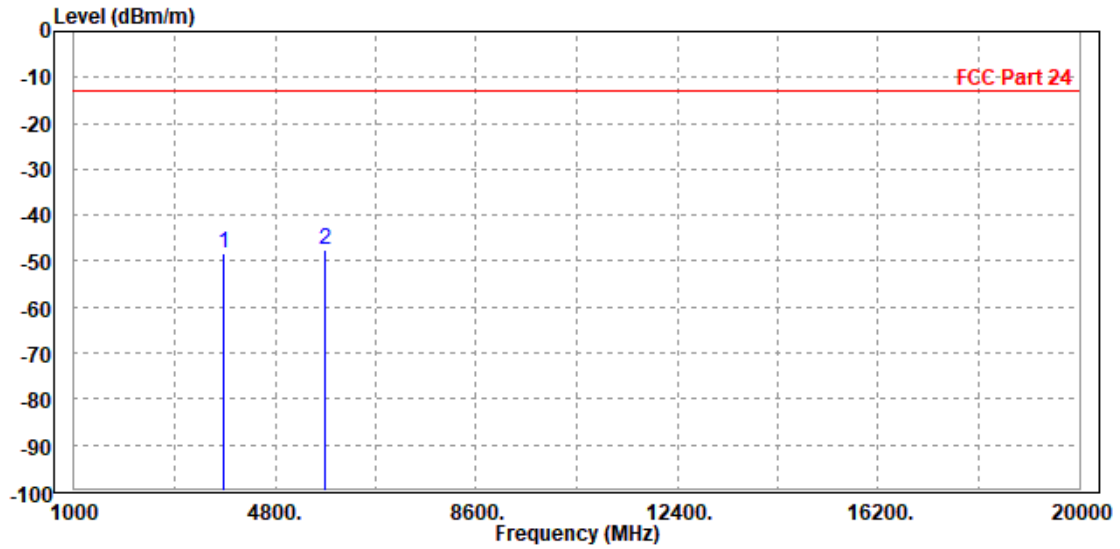



3.7 PEAK TO AVERAGE RATIO

3.7.1 LIMITS OF PEAK TO AVERAGE RATIO MEASUREMENT

In measuring transmissions in this band using an average power technique, the peak to-average ratio (PAR) of the transmission may not exceed 13 dB

3.7.2 TEST SETUP

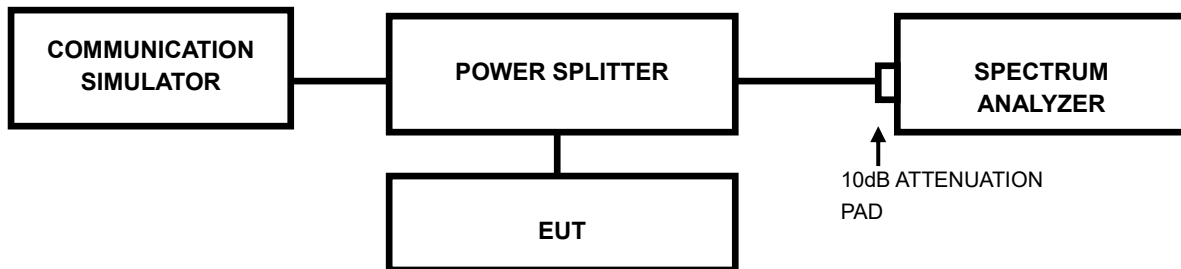

3.7.3 TEST PROCEDURES

1. Set resolution/measurement bandwidth \geq signal's occupied bandwidth;
2. Set the number of counts to a value that stabilizes the measured CCDF curve;
3. Record the maximum PAPR level associated with a probability of 0.1%.



BUREAU
VERITAS

Test Report No.: W7L-P22090015-1RF05

3.7.4 TEST RESULTS

Please Refer to Appendix Of this test report.



Test Report No.: W7L-P22090015-1RF05

4 INFORMATION ON THE TESTING LABORATORIES

We, BV 7LAYERS COMMUNICATIONS TECHNOLOGY (SHENZHEN) CO. LTD., were founded in 2015 to provide our best service in EMC, Radio, Telecom and Safety consultation. Our laboratories are accredited and approved according to ISO/IEC 17025.

If you have any comments, please feel free to contact us at the following:

Shenzhen EMC/RF Lab:

Tel: +86-755-88696566

Fax: +86-755-88696577

Email: customerservice.sw@bureauveritas.com

Web Site: www.adt.com.tw

The address and road map of all our labs can be found in our web site also.



Test Report No.: W7L-P22090015-1RF05

5 MODIFICATIONS RECORDERS FOR ENGINEERING CHANGES TO THE EUT BY THE LAB

No any modifications are made to the EUT by the lab during the test.



6 Appendix

APPENDIX A: EFFECTIVE (ISOTROPIC) RADIATED POWER OUTPUT DATA

Test Result

Band	Channel	ERP/EIRP(dBm)	Limit(dBm)	Verdict
GSM1900	512	28.65	33	PASS
GSM1900	661	28.76	33	PASS
GSM1900	810	28.75	33	PASS

Band	Channel	Slot	Power(dBm)	Limit(dBm)	Verdict
EGPRS1900	512	1	25.42	33	PASS
EGPRS1900	512	2	25.14	33	PASS
EGPRS1900	512	3	22.91	33	PASS
EGPRS1900	512	4	20.78	33	PASS
EGPRS1900	661	1	25.44	33	PASS
EGPRS1900	661	2	25.34	33	PASS
EGPRS1900	661	3	23.27	33	PASS
EGPRS1900	661	4	21.57	33	PASS
EGPRS1900	810	1	24.83	33	PASS
EGPRS1900	810	2	24.93	33	PASS
EGPRS1900	810	3	22.52	33	PASS
EGPRS1900	810	4	21.06	33	PASS



Test Report No.: W7L-P22090015-1RF05

APPENDIX B: PEAK-TO-AVERAGE RATIO(CCDF)

Test Result

Band	Channel	Result(dB)	Limit(dB)	Verdict
GSM1900	512	2.6	13	PASS
GSM1900	661	2.6	13	PASS
GSM1900	810	2.61	13	PASS
EGPRS1900	512	5.37	13	PASS
EGPRS1900	661	5.24	13	PASS
EGPRS1900	810	5.29	13	PASS



BUREAU
VERITAS

Test Report No.: W7L-P22090015-1RF05

Test Graphs





BUREAU VERITAS

Test Report No.: W7L-P22090015-1RF05

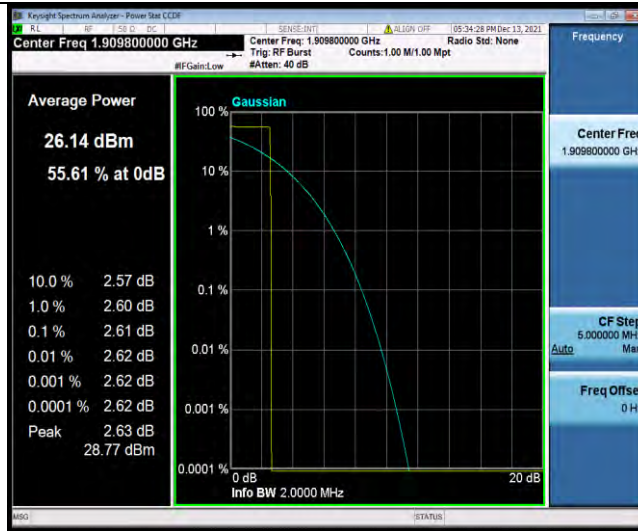

EGPRS1900-512-2

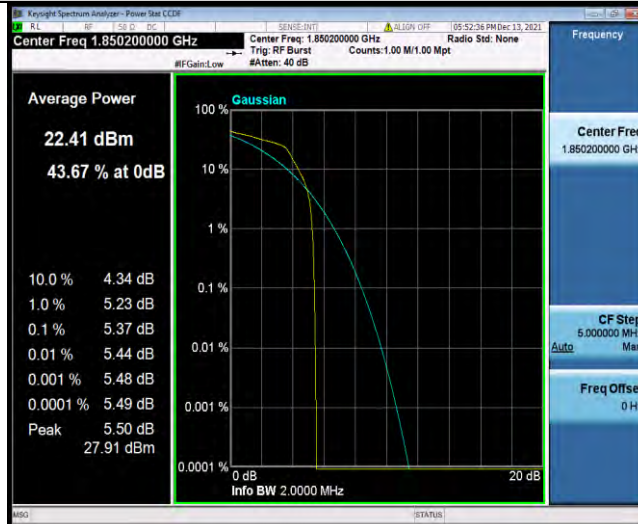

EGPRS1900-661-2



EGPRS1900-810-2



BUREAU
VERITAS

Test Report No.: W7L-P22090015-1RF05

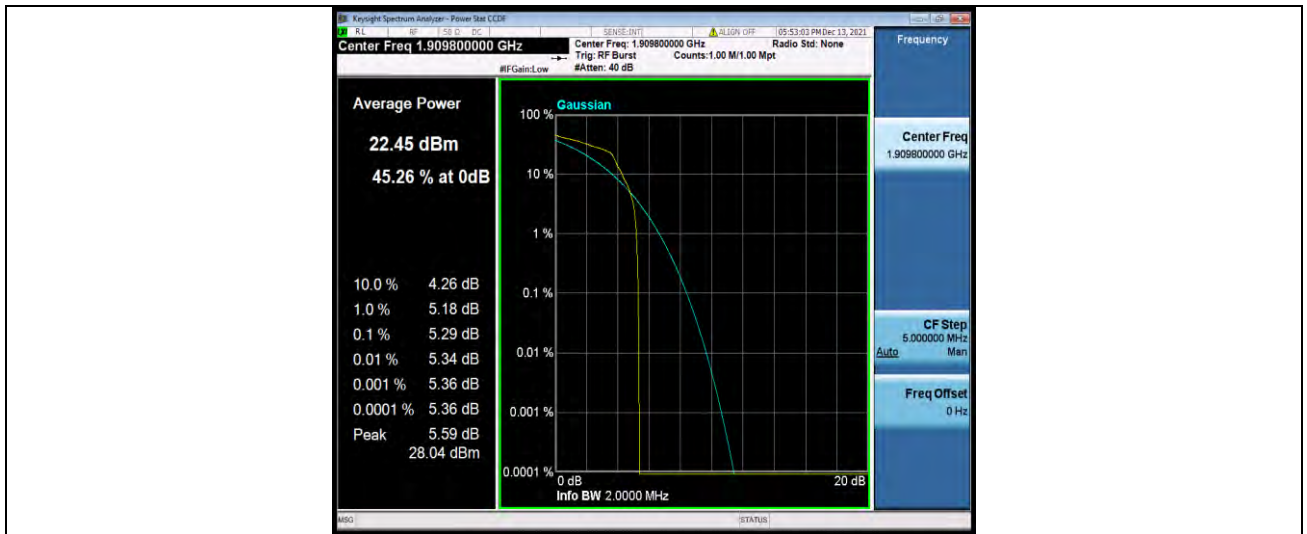



**BUREAU
VERITAS**

Test Report No.: W7L-P22090015-1RF05

APPENDIX C: 26DB BANDWIDTH AND OCCUPIED BANDWIDTH

Test Result

Band	Channel	Occupied Bandwidth (MHz)	26dB Bandwidth (MHz)	Limit (MHz)	Verdict
GSM1900	512	0.24164	0.3070	---	PASS
GSM1900	661	0.24259	0.2981	---	PASS
GSM1900	810	0.24199	0.3172	---	PASS
EGPRS1900	512	0.25231	0.3145	---	PASS
EGPRS1900	661	0.25090	0.3197	---	PASS
EGPRS1900	810	0.24471	0.3103	---	PASS



BUREAU
VERITAS

Test Report No.: W7L-P22090015-1RF05

Test Graphs

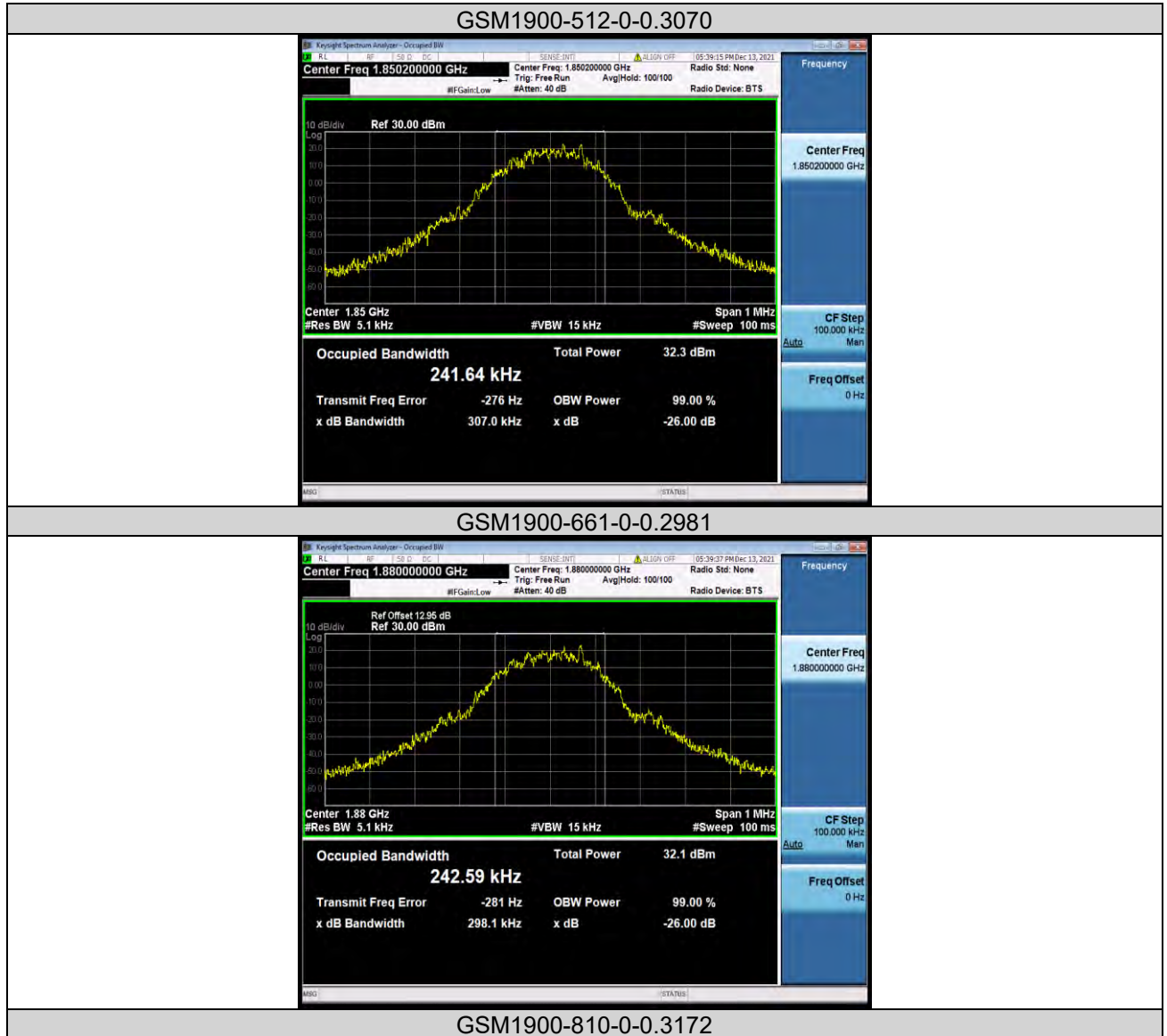



BUREAU VERITAS

Test Report No.: W7L-P22090015-1RF05

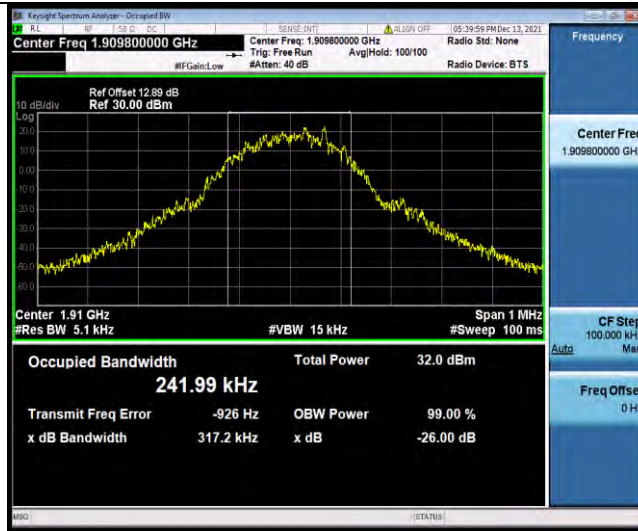

EGPRS1900-512-2-0.3145

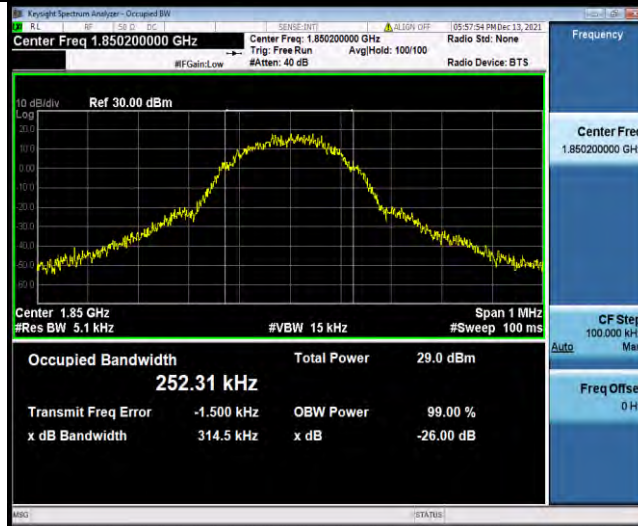

EGPRS1900-661-2-0.3197

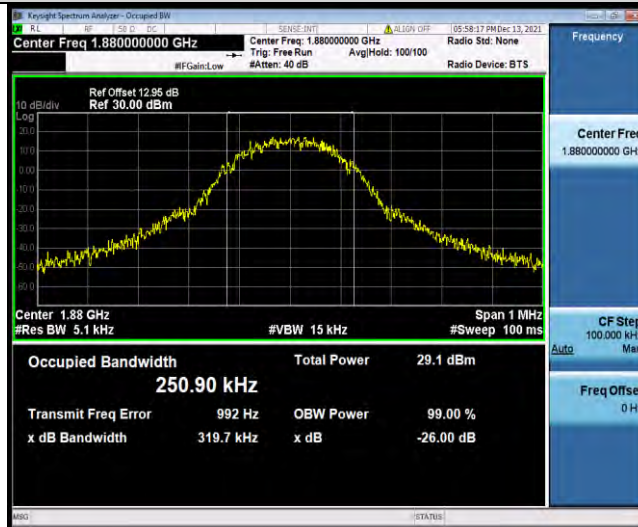

EGPRS1900-810-2-0.3103



**BUREAU
VERITAS**

Test Report No.: W7L-P22090015-1RF05

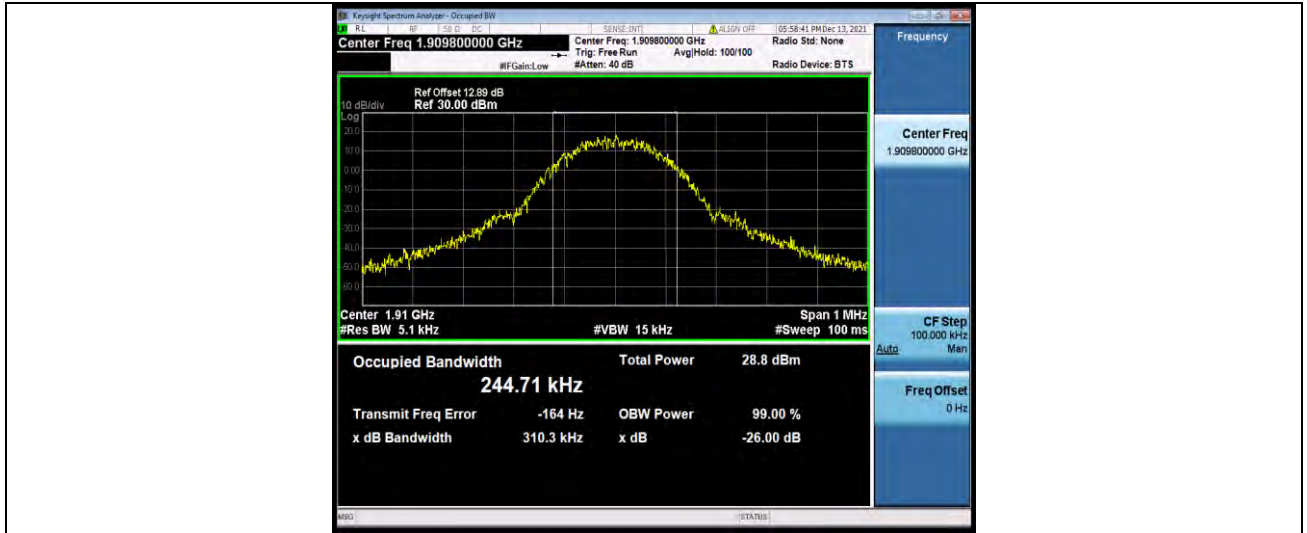

APPENDIX D: BAND EDGE

Test Result

Band	Channel	Freq (MHz)	Result (dBm)	Limit(dBm)	Verdict
GSM1900	512	1849.99	-16.57	-13	PASS
GSM1900	810	1910.02	-15.26	-13	PASS
EGPRS1900	512	1849.98	-18.76	-13	PASS
EGPRS1900	810	1910.02	-21.14	-13	PASS

Test Graphs

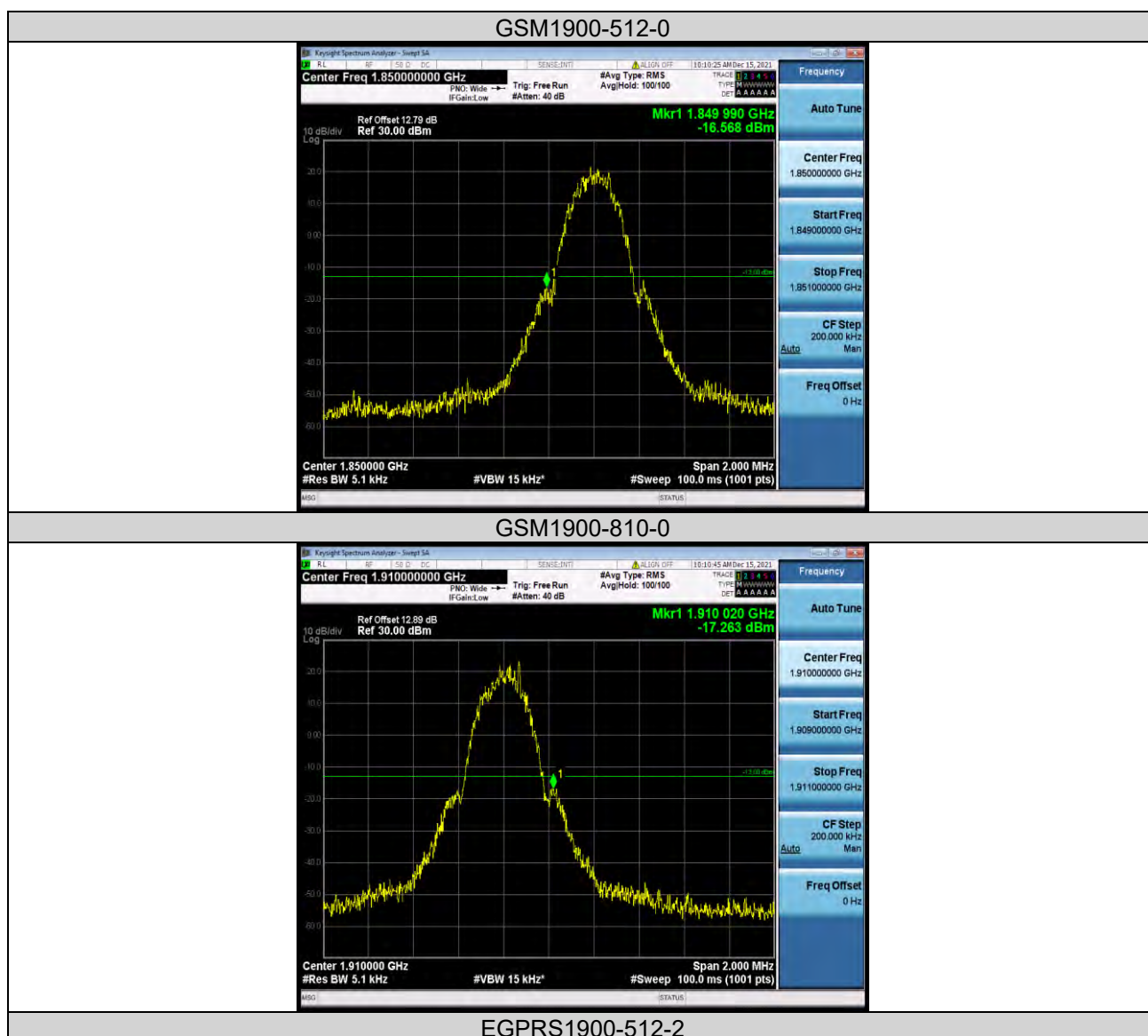



BUREAU VERITAS

Test Report No.: W7L-P22090015-1RF05

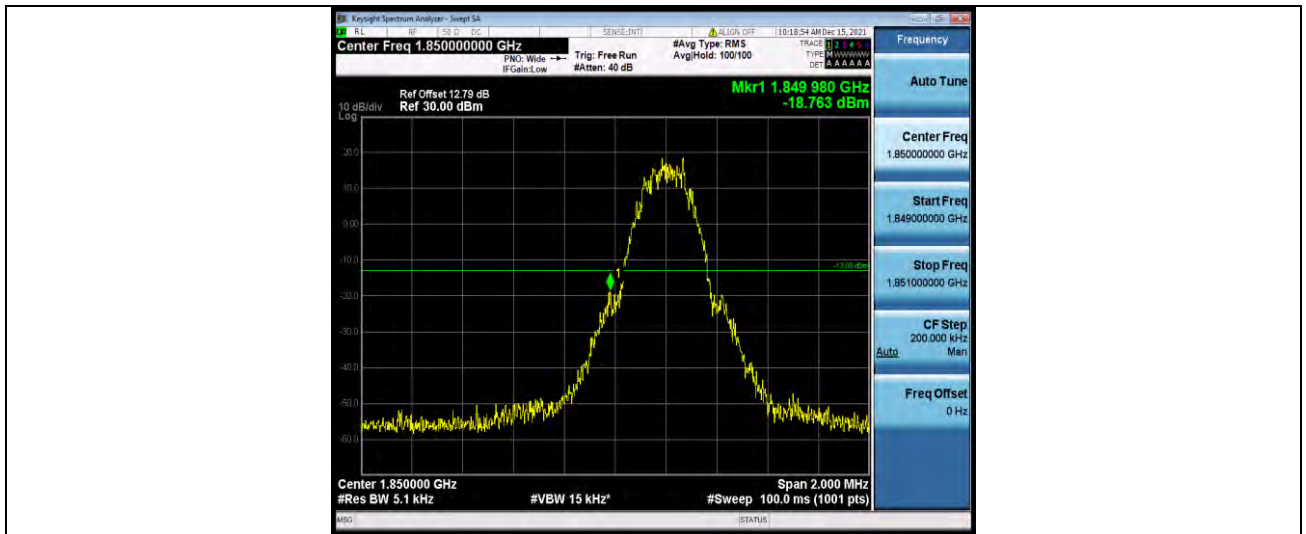

EGPRS1900-810-2

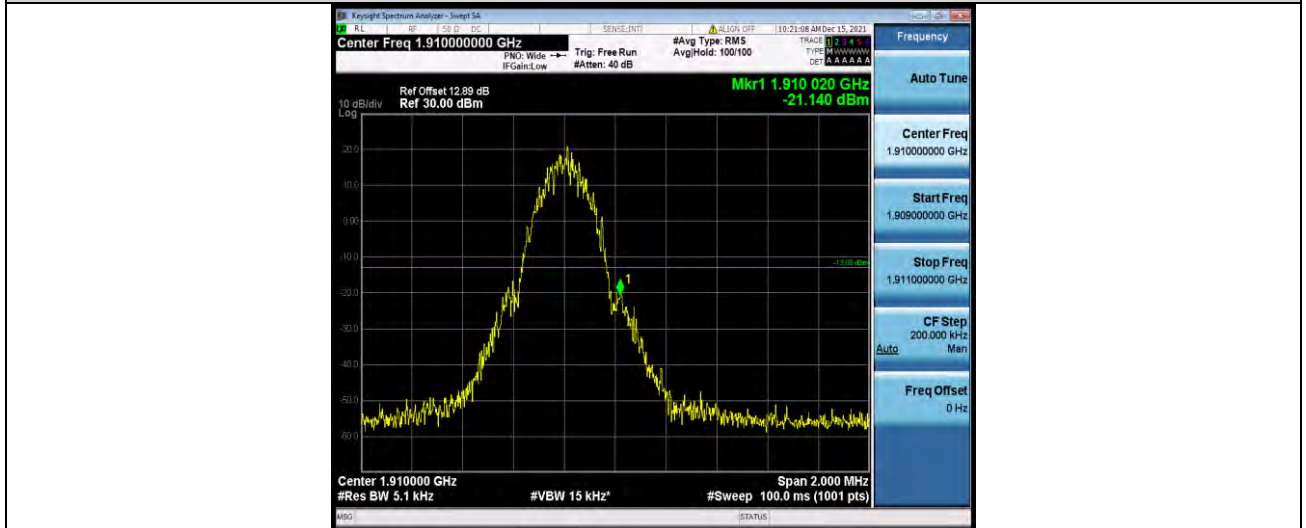



APPENDIX E: CONDUCTED SPURIOUS EMISSION

Test Result

Band	Channel	Frequency Range(MHz)	Max.Freq. (MHz)	Result (dBm)	Limit (dBm)	Verdict
GSM1900	512	30~1000MHz	889.39	-48.14	-13	PASS
GSM1900	512	1000~3000MHz	2636.8	-46.34	-13	PASS
GSM1900	512	3000~20000MHz	19117.7	-43.23	-13	PASS
GSM1900	661	30~1000MHz	870.51	-48.14	-13	PASS
GSM1900	661	1000~3000MHz	2633.13	-46.39	-13	PASS
GSM1900	661	3000~20000MHz	19374.97	-43.21	-13	PASS
GSM1900	810	30~1000MHz	919.91	-48	-13	PASS
GSM1900	810	1000~3000MHz	2649.47	-46.36	-13	PASS
GSM1900	810	3000~20000MHz	19058.2	-43.24	-13	PASS
EGPRS1900	512	30~1000MHz	883.41	-47.42	-13	PASS
EGPRS1900	512	1000~3000MHz	2640.93	-46.37	-13	PASS
EGPRS1900	512	3000~20000MHz	19108.63	-43.23	-13	PASS
EGPRS1900	661	30~1000MHz	941.9	-47.31	-13	PASS
EGPRS1900	661	1000~3000MHz	2622.87	-46.34	-13	PASS
EGPRS1900	661	3000~20000MHz	19108.07	-43.25	-13	PASS
EGPRS1900	810	30~1000MHz	392.52	-47.41	-13	PASS
EGPRS1900	810	1000~3000MHz	2628.07	-46.37	-13	PASS
EGPRS1900	810	3000~20000MHz	19129.6	-43.31	-13	PASS



BUREAU
VERITAS

Test Report No.: W7L-P22090015-1RF05

Test Graphs

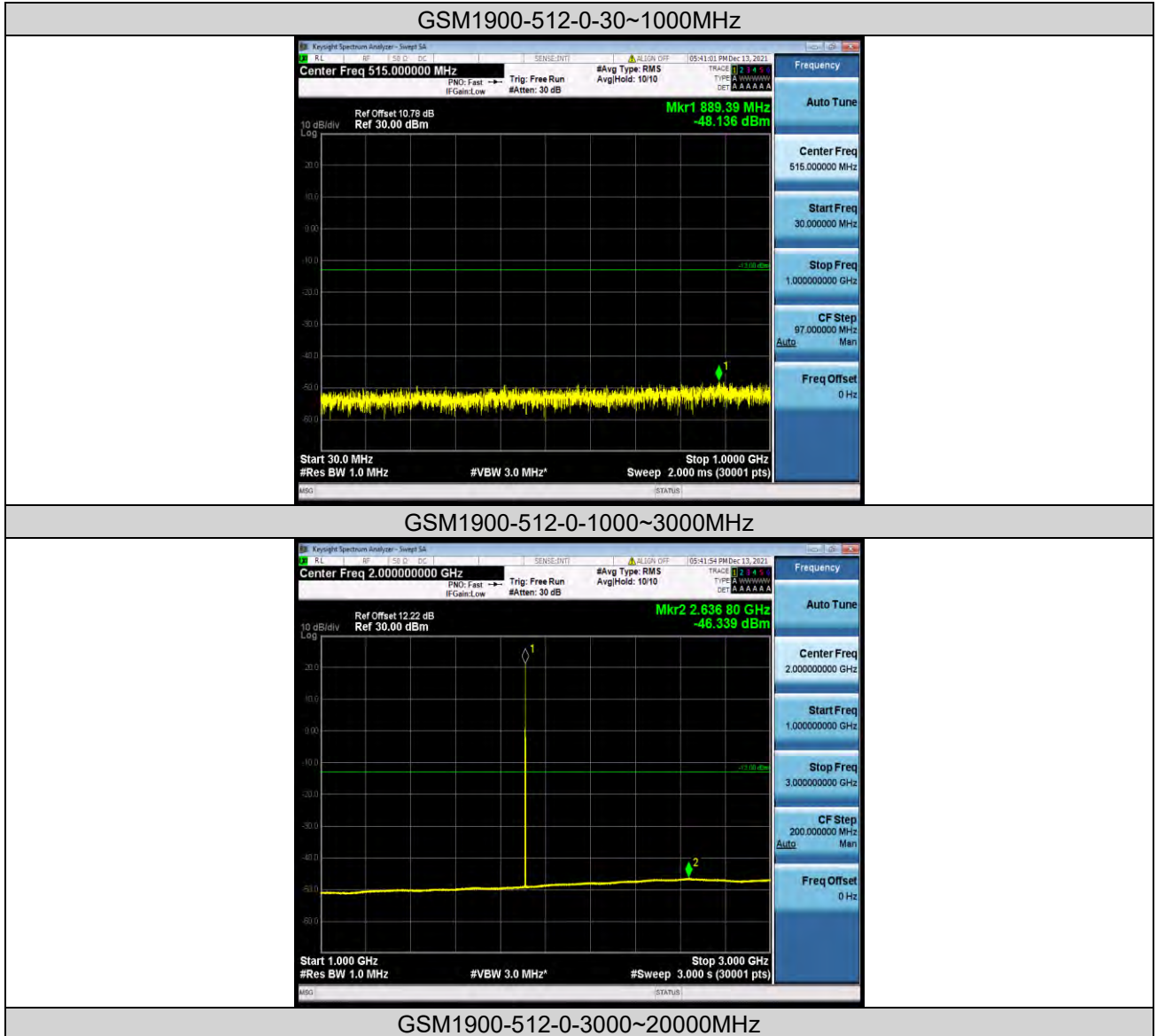



BUREAU VERITAS

Test Report No.: W7L-P22090015-1RF05



GSM1900-661-0-30~1000MHz



GSM1900-661-0-1000~3000MHz



GSM1900-661-0-3000~20000MHz



BUREAU VERITAS

Test Report No.: W7L-P22090015-1RF05



GSM1900-810-0-30~1000MHz

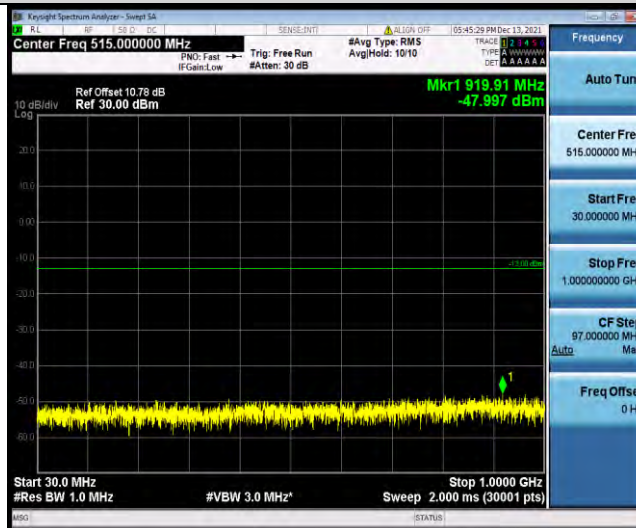

GSM1900-810-0-1000~3000MHz



GSM1900-810-0-3000~20000MHz



BUREAU VERITAS

Test Report No.: W7L-P22090015-1RF05

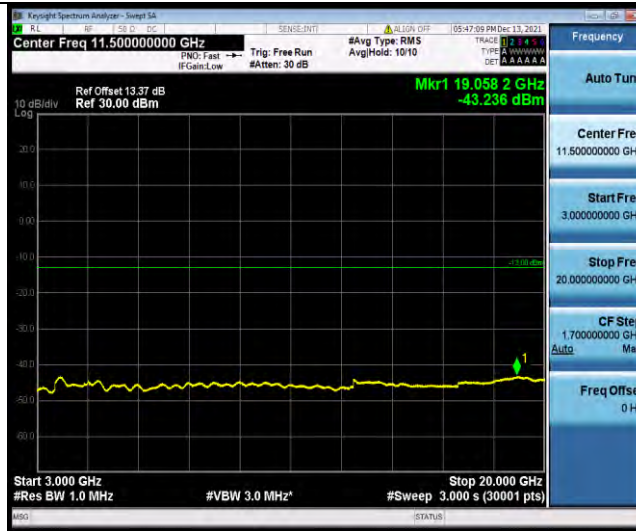

EGPRS1900-512-2-30~1000MHz

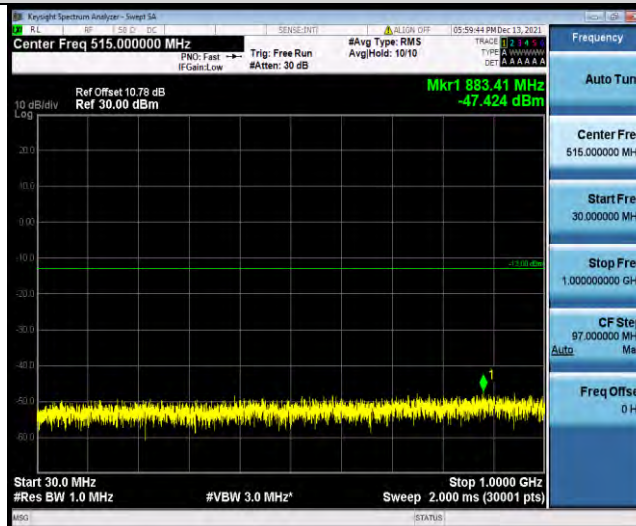

EGPRS1900-512-2-1000~3000MHz



EGPRS1900-512-2-3000~20000MHz



BUREAU VERITAS

Test Report No.: W7L-P22090015-1RF05



EGPRS1900-661-2-30~1000MHz

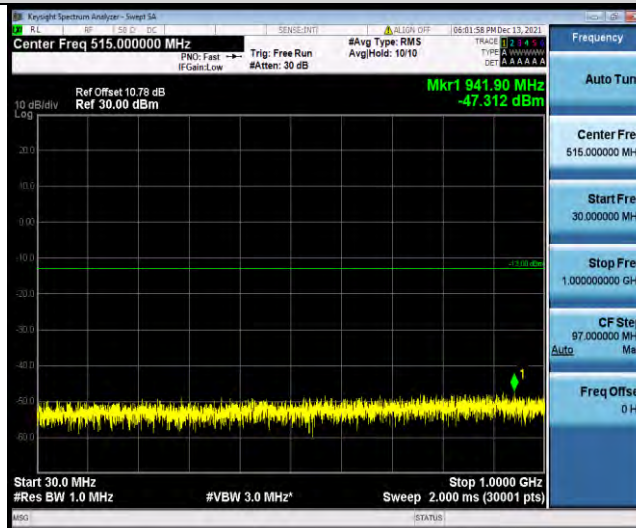

EGPRS1900-661-2-1000~3000MHz



EGPRS1900-661-2-3000~20000MHz

BV 7Layers Communications Technology (Shenzhen) Co., Ltd

No.B102, Dazu Chuangxin Mansion, North of Beihuan Avenue, North Area, Hi-Tech Industrial Park, Nanshan District, Shenzhen, Guangdong, China

Tel: +86 755 8869 6566
Fax: +86 755 8869 6577

Email: customerservice.sw@bureauveritas.com



BUREAU VERITAS

Test Report No.: W7L-P22090015-1RF05



EGPRS1900-810-2-30~1000MHz

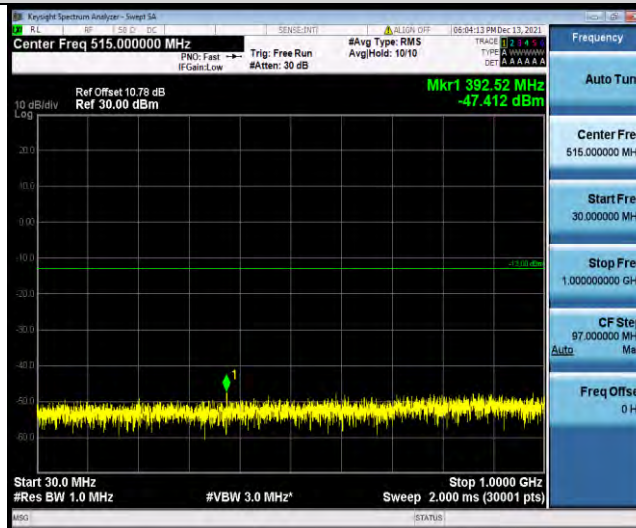

EGPRS1900-810-2-1000~3000MHz



EGPRS1900-810-2-3000~20000MHz



BUREAU
VERITAS

Test Report No.: W7L-P22090015-1RF05

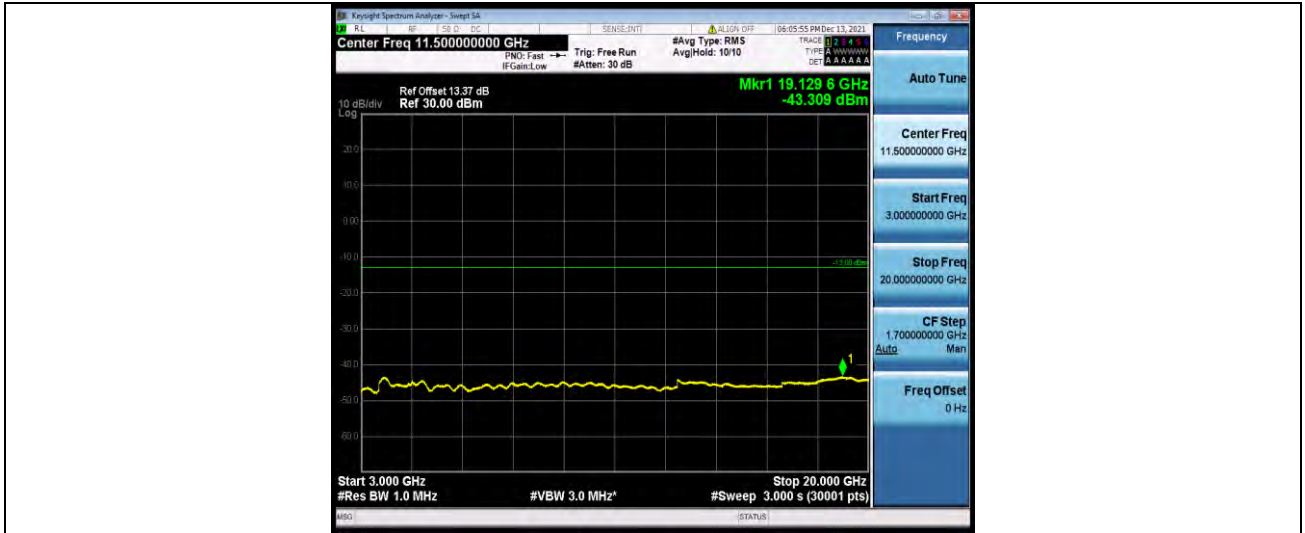

BV 7Layers Communications Technology
(Shenzhen) Co., Ltd

No.B102, Dazu Chuangxin Mansion, North of Beihuan
Avenue, North Area, Hi-Tech Industrial Park, Nanshan
District, Shenzhen, Guangdong, China

Tel: +86 755 8869 6566
Fax: +86 755 8869 6577
Email: customerservice.sw@bureauveritas.com



APPENDIX F: FREQUENCY STABILITY

Test Result

Voltage							
Band	Channel	Voltage [Vdc]	Temperature (°C)	Deviation (Hz)	Deviation (ppm)	Limit (ppm)	Verdict
GSM1900	512	VL	NT	0.55	0.000297	±2.5	PASS
GSM1900	512	VN	NT	5.07	0.002740	±2.5	PASS
GSM1900	512	VH	NT	3.94	0.002129	±2.5	PASS
GSM1900	661	VL	NT	1.84	0.000979	±2.5	PASS
GSM1900	661	VN	NT	4.94	0.002628	±2.5	PASS
GSM1900	661	VH	NT	2.36	0.001255	±2.5	PASS
GSM1900	810	VL	NT	-10.53	-0.005514	±2.5	PASS
GSM1900	810	VN	NT	-1.94	-0.001016	±2.5	PASS
GSM1900	810	VH	NT	3.29	0.001723	±2.5	PASS
EGPRS1900	512	VL	NT	8.33	0.004502	±2.5	PASS
EGPRS1900	512	VN	NT	-3.75	-0.002027	±2.5	PASS
EGPRS1900	512	VH	NT	-6.72	-0.003632	±2.5	PASS
EGPRS1900	661	VL	NT	0.84	0.000447	±2.5	PASS
EGPRS1900	661	VN	NT	3.68	0.001957	±2.5	PASS
EGPRS1900	661	VH	NT	3.13	0.001665	±2.5	PASS
EGPRS1900	810	VL	NT	5.84	0.003058	±2.5	PASS
EGPRS1900	810	VN	NT	13.24	0.006933	±2.5	PASS
EGPRS1900	810	VH	NT	5.20	0.002723	±2.5	PASS

Temperature							
Band	Channel	Voltage [Vdc]	Temperature (°C)	Deviation (Hz)	Deviation (ppm)	Limit (ppm)	Verdict
GSM1900	512	NV	-30	-9.10	-0.004918	±2.5	PASS
GSM1900	512	NV	-20	-7.33	-0.003962	±2.5	PASS
GSM1900	512	NV	-10	-1.61	-0.000870	±2.5	PASS
GSM1900	512	NV	0	4.20	0.002270	±2.5	PASS
GSM1900	512	NV	10	-1.65	-0.000892	±2.5	PASS
GSM1900	512	NV	20	3.71	0.002005	±2.5	PASS
GSM1900	512	NV	30	8.98	0.004854	±2.5	PASS
GSM1900	512	NV	40	8.10	0.004378	±2.5	PASS
GSM1900	512	NV	50	3.10	0.001675	±2.5	PASS
GSM1900	661	NV	-30	1.97	0.001048	±2.5	PASS
GSM1900	661	NV	-20	11.11	0.005910	±2.5	PASS
GSM1900	661	NV	-10	13.59	0.007229	±2.5	PASS
GSM1900	661	NV	0	18.60	0.009894	±2.5	PASS
GSM1900	661	NV	10	10.75	0.005718	±2.5	PASS
GSM1900	661	NV	20	7.88	0.004191	±2.5	PASS
GSM1900	661	NV	30	-11.11	-0.005910	±2.5	PASS
GSM1900	661	NV	40	8.94	0.004755	±2.5	PASS
GSM1900	661	NV	50	-2.16	-0.001149	±2.5	PASS



GSM1900	810	NV	-30	-5.46	-0.002859	±2.5	PASS
GSM1900	810	NV	-20	-7.46	-0.003906	±2.5	PASS
GSM1900	810	NV	-10	0.84	0.000440	±2.5	PASS
GSM1900	810	NV	0	4.68	0.002451	±2.5	PASS
GSM1900	810	NV	10	2.78	0.001456	±2.5	PASS
GSM1900	810	NV	20	0.61	0.000319	±2.5	PASS
GSM1900	810	NV	30	8.43	0.004414	±2.5	PASS
GSM1900	810	NV	40	7.10	0.003718	±2.5	PASS
GSM1900	810	NV	50	-0.10	-0.000052	±2.5	PASS
EGPRS1900	512	NV	-30	-8.14	-0.004400	±2.5	PASS
EGPRS1900	512	NV	-20	7.07	0.003821	±2.5	PASS
EGPRS1900	512	NV	-10	-5.81	-0.003140	±2.5	PASS
EGPRS1900	512	NV	0	0.32	0.000173	±2.5	PASS
EGPRS1900	512	NV	10	-2.13	-0.001151	±2.5	PASS
EGPRS1900	512	NV	20	5.71	0.003086	±2.5	PASS
EGPRS1900	512	NV	30	4.55	0.002459	±2.5	PASS
EGPRS1900	512	NV	40	1.52	0.000822	±2.5	PASS
EGPRS1900	512	NV	50	8.78	0.004745	±2.5	PASS
EGPRS1900	661	NV	-30	5.62	0.002989	±2.5	PASS
EGPRS1900	661	NV	-20	-1.19	-0.000633	±2.5	PASS
EGPRS1900	661	NV	-10	2.36	0.001255	±2.5	PASS
EGPRS1900	661	NV	0	8.62	0.004585	±2.5	PASS
EGPRS1900	661	NV	10	-13.37	-0.007112	±2.5	PASS
EGPRS1900	661	NV	20	-7.20	-0.003830	±2.5	PASS
EGPRS1900	661	NV	30	-5.91	-0.003144	±2.5	PASS
EGPRS1900	661	NV	40	-1.65	-0.000878	±2.5	PASS
EGPRS1900	661	NV	50	1.36	0.000723	±2.5	PASS
EGPRS1900	810	NV	-30	4.75	0.002487	±2.5	PASS
EGPRS1900	810	NV	-20	-7.26	-0.003801	±2.5	PASS
EGPRS1900	810	NV	-10	-5.39	-0.002822	±2.5	PASS
EGPRS1900	810	NV	0	-0.10	-0.000052	±2.5	PASS
EGPRS1900	810	NV	10	8.23	0.004309	±2.5	PASS
EGPRS1900	810	NV	20	11.20	0.005864	±2.5	PASS
EGPRS1900	810	NV	30	3.52	0.001843	±2.5	PASS
EGPRS1900	810	NV	40	4.13	0.002163	±2.5	PASS
EGPRS1900	810	NV	50	-2.00	-0.001047	±2.5	PASS

---END---