



# NFC TEST REPORT

No.I21Z61147-IOT01

for

**HMD Global Oy**

**Smart Phone**

**TA-1399**

**FCC ID : 2AJOTTA-1399**

with

**Hardware Version: V1.0**

**Software Version: 04US\_0\_033**

**Issued Date: 2021-09-03**

**Note:**

The test results in this test report relate only to the devices specified in this report. This report shall not be reproduced except in full without the written approval of CTTL.

The report must not be used by the client to claim product certification, approval, or endorsement by NVLAP, NIST, or any agency of the U.S.Government.

**Test Laboratory:**

**CTTL-Telecommunication Technology Labs, CAICT**

No. 52, Huayuan North Road, Haidian District, Beijing, P. R. China 100191.

Tel:+86(0)10-62304633-2512, Fax:+86(0)10-62304633-2504

Email: [cttl\\_terminals@caict.ac.cn](mailto:cttl_terminals@caict.ac.cn), website: [www.caict.ac.cn](http://www.caict.ac.cn)



## **REPORT HISTORY**

<b>Report Number</b>	<b>Revision</b>	<b>Description</b>	<b>Issue Date</b>
I21Z61147-IOT01	Rev.0	1st edition	2021-09-03

## **CONTENTS**

<b>1. TEST LABORATORY .....</b>	<b>4</b>
<b>1.1. INTRODUCTION &amp; ACCREDITATION.....</b>	<b>4</b>
<b>1.2. TESTING LOCATION .....</b>	<b>4</b>
<b>1.3. TESTING ENVIRONMENT.....</b>	<b>5</b>
<b>1.4. PROJECT DATA .....</b>	<b>5</b>
<b>1.5. SIGNATURE.....</b>	<b>5</b>
<b>2. CLIENT INFORMATION.....</b>	<b>5</b>
<b>2.1. APPLICANT INFORMATION.....</b>	<b>6</b>
<b>2.2. MANUFACTURER INFORMATION.....</b>	<b>6</b>
<b>3. EQUIPMENT UNDER TEST (EUT) AND ANCILLARY EQUIPMENT (AE) .....</b>	<b>5</b>
<b>3.1. ABOUT EUT .....</b>	<b>7</b>
<b>3.2. INTERNAL IDENTIFICATION OF EUT .....</b>	<b>7</b>
<b>3.3. INTERNAL IDENTIFICATION OF AE .....</b>	<b>7</b>
<b>3.4. EUT SET-UPS.....</b>	<b>8</b>
<b>4. REFERENCE DOCUMENTS .....</b>	<b>9</b>
<b>4.1. DOCUMENTS SUPPLIED BY APPLICANT .....</b>	<b>9</b>
<b>4.2. REFERENCE DOCUMENTS FOR TESTING.....</b>	<b>9</b>
<b>5. TEST RESULTS .....</b>	<b>9</b>
<b>5.1. SUMMARY OF TEST RESULTS .....</b>	<b>10</b>
<b>5.2. STATEMENTS.....</b>	<b>11</b>
<b>6. TEST FACILITIES UTILIZED .....</b>	<b>12</b>
<b>7. MEASUREMENT UNCERTAINTY .....</b>	<b>13</b>
<b>ANNEX A: EUT PARAMETERS.....</b>	<b>14</b>
<b>ANNEX B: DETAILED TEST RESULTS.....</b>	<b>15</b>
<b>ANNEX C: PERSONS INVOLVED IN THIS TESTING .....</b>	<b>30</b>
<b>ANNEX D: ACCREDITATION CERTIFICATE .....</b>	<b>32</b>



## **1. Test Laboratory**

### **1.1. Introduction & Accreditation**

**Telecommunication Technology Labs, CAICT** is an ISO/IEC 17025:2017 accredited test laboratory under NATIONAL VOLUNTARY LABORATORY ACCREDITATION PROGRAM (NVLAP) with lab code 600118-0, and is also an FCC accredited test laboratory (CN5017), and ISED accredited test laboratory (ISED#: 24849). The detail accreditation scope can be found on NVLAP website.

### **1.2. Testing Location**

Location 1: CTTL(BDA)

Address: No. 18A, Kangding Street, Beijing Economic-Technology Development Area, Beijing, P. R. China 100176

Location 2: CTTL(huayuan North Road)

Address: No. 52, Huayuan North Road, Haidian District, Beijing, P. R. China 100191

### 1.3. Testing Environment

Normal Temperature: 15-35°C  
Extreme Temperature: -20/+50°C  
Normal Relative Humidity: 20-75%  
Normal Air Pressure: 86Kpa-106Kpa

### 1.4. Project data

Testing Start Date: 2021-08-17  
Testing End Date: 2021-08-31

### 1.5. Signature



---

Zhou Bin  
(Prepared this test report)



---

Zhang Qiang  
(Reviewed this test report)



---

Zhu Liang  
(Approved this test report)



## **2. Client Information**

### **2.1. Applicant Information**

Company Name: HMD Global Oy  
Address: Bertel Jungin aukio 9,02600 Espoo, Finland  
Contact: Rosario Casillo  
Email: rosario.casillo@hmdglobal.com  
Telephone: +393 316272922  
Fax: /

### **2.2. Manufacturer Information**

Company Name: HMD Global Oy  
Address: Bertel Jungin aukio 9,02600 Espoo, Finland  
Contact: Rosario Casillo  
Email: rosario.casillo@hmdglobal.com  
Telephone: +393 316272922  
Fax: /

### 3. Equipment Under Test (EUT) and Ancillary Equipment (AE)

#### 3.1. About EUT

Description	Smart Phone
Model name/HVIN	TA-1399
Brand Name	Nokia
FCC ID	2AJOTTA-1399
GSM Frequency Bands	GSM 850/900/1800/1900
UMTS Frequency Bands	FDD I/ II/ V/ VIII
LTE Frequency Bands	FDD 1/2/3/4/5/7/8/12/13/17/20/25/26/66/71 TDD 38/39/40/41
5G NR	N 25/41/66/71
Operating Temperature	-10/+55°C
Nominal Voltage	3.8V
Extreme High Voltage	4.2V
Extreme Low Voltage	3.65V

#### 3.2. Internal Identification of EUT

EUT ID*	IMEI/SNI	HW Version	SW Version	Date of receipt
64a	354773220009801	V1.0	04US_0_020	2021-07-26
78a	354773220011310	V1.0	04US_0_020	2021-07-26

\*EUT ID: is used to identify the test sample in the lab internally.

#### 3.3. Internal Identification of AE

AE ID*	Description	SN	Note
AE1	Battery	/	AE1
AE2	Adapter	/	AE2
AE3	USB Cable	/	AE3

AE1

Model	/
Manufacturer	TIANJIN LISHEN BATTERY JOINT-STOCK CO.,LTD.

Capacitance 4370mAh  
 Nominal voltage 3.87V

AE2

Model 1-CHUSQ302-097  
 Manufacturer HUIZHOU PUAN ELECTRONICS CO.,LTD  
 Length /

AE3

Model /  
 Manufacturer Huizhou Washin Electronics Co.,Ltd  
 Length /

\*AE ID: is used to identify the ancillary equipment in the lab internally.

**3.4. EUT Set-ups**

**Table 1: Eut Set-ups**

EUT Set-up No.	Combination of EUT and AE	Remarks
Set.NFC01	64a + AE1 + AE2 + AE3 + NFC Card	--
Set.NFC02	64a + AE1 + NFC Card	--
Set.NFC03	78a	--

The Transmit State of NFC: the NFC function is on. The EUT will transmit the NFC data and command continuously during the test.

The Transmit state without modulation: The EUT will transmit the CW signal at the operating frequency.



## **4. Reference Documents**

### **4.1. Documents supplied by applicant**

EUT parameters, referring to Annex A for detailed information, are supplied by the client or manufacturer, which are the bases of testing.

### **4.2. Reference Documents for testing**

The following documents listed in this section are referred for testing.

<b>Reference</b>	<b>Title</b>	<b>Version</b>
CFR 47 Part 2	Part 2 — Frequency Allocations and Radio Treaty Matters; General Rules and Regulations.	2019
CFR 47 Part 15	Part 15 — Radio Frequency Devices.  Subpart C — Intentional Radiators.  § 15.35 Measurement detector functions and bandwidths.  § 15.207 Conducted limits.  § 15.209 Radiated emission limits, general requirements.  § 15.215 Additional provisions to the general radiated emission limitations.  § 15.225 Operation within the band 13.110–14.010 MHz.	2019
ANSI C63.10	American National Standard of Procedures for Compliance  Testing of Unlicensed Wireless Devices	2013

## 5. Test Results

### 5.1. Summary of Test Results

**Table 2: Summary of Test Results**

No	Test Cases	Clause in Regulation	Section in This Report	Verdict
1	Electric Field Strength of Fundamental Emissions	CFR 47 § 15.225(a)	B.1	P,Set. NFC02
2	Electric Field Strength of Outside the Allocated Bands	CFR 47 § 15.225(b) CFR 47 § 15.225(c)		P,Set. NFC02
3	Electric Field Radiated Emissions	CFR 47 § 15.209	B.2	P,Set. NFC01
		CFR 47 § 15.225(d)	B.3	P,Set. NFC01
4	Frequency Tolerance	CFR 47 § 15.225(e)	B.4	P,Set. NFC03
5	20dB Bandwidth	CFR 47 § 15.215(c)	B.5	P,Set. NFC03
6	Conducted Emissions	CFR 47 § 15.207	B.6	P,Set. NFC01
The measurement is carried out according to ANSI C63.10. See <b>ANNEX B</b> for details.				

Note: All combinations were tested, and only the worst results are shown in this report.

#### **Test Conditions:**

For this report, all the test cases listed above were tested under normal Temperature, Voltage, humidity and Air Pressure except the Frequency Tolerance test case. The specific conditions of Frequency Tolerance test case are listed in section B.4.3

**See Table 3 for terms for result verdict:**

**Table 3 Terms for result verdict**

P	Pass, The EUT complies with the essential requirements in the standard.
NP	Not Perform, The test was not performed by CTTL
NA	Not Applicable, The test was not applicable

F	Fail, The EUT does not comply with the essential requirements in the standard
---	---

## 5.2. Statements

The test cases listed in Section 5.1 of this report for the EUT specified in Section 3 were performed by CTTL according to the reference documents in Section 4.

The EUT meets all applicable requirements of the regulations and standards in Section 4.2

## 6. Test Facilities Utilized

Table 4: Test Facilities Utilized

NO.	NAME	TYPE	SERIES NUMBER	PRODUCER	CAL. DUE DATE	CAL. INTERVAL
1.	Spectrum Analyzer	RSA3408A	B010277	Tektronix	2021-10-23	1 Year
2.	Climatic chamber	SH242	93008658	ESPEC	2022-01-22	1 Year
3.	LISN	ENV216	101459	Rohde & Schwarz	2022-02-22	1 Year
4.	Test Receiver	ESU26	1100766	Rohde & Schwarz	2022-02-23	1 Year
5.	Test Receiver	ESU26	1100376	Rohde & Schwarz	2021-10-04	1 Year
6.	H-field Antenna	HFH2-Z2	829324	Rohde & Schwarz	2021-12-10	1 Year
7.	Test Receiver	ESU26	100235	Rohde & Schwarz	2022-02-23	1 Year
8.	BiLog Antenna	VULB9163	482	Schwarzbeck	2021-11-04	1 year

## 7. Measurement Uncertainty

Table 5: Measurement Uncertainty

Item	Uncertainty
Frequency Tolerance	$U = 77 \text{ Hz, } k=2$
20dB Bandwidth	$U = 77 \text{ Hz, } k=2$
Radiated Emissions (<30MHz)	$U = 5.82 \text{ dB, } k=2$
Radiated Emissions ( $\geq 30\text{MHz}$ )	$U = 5.84 \text{ dB, } k=2$
Conducted emission	$U = 3.1 \text{ dB, } k=2$



## **ANNEX A: EUT parameters**

/

## **ANNEX B: Detailed Test Results**

### **B.1. Electric Field Strength of Fundamental and Outside the Allocated bands**

#### **B.1.1. Reference**

See Clause 4, Clause 5 of ANSI C63.10-2013 generally.

#### **B.1.2. Measurement Methods**

The transmitter carrier output levels (E-Field) from the EUT are measured in a semi-anechoic chamber. The EUT is placed on a non-conductive stand of 80cm high, and at a measurement distance of 3m from the receiving antenna. The center of the receiving loop antenna is 1.0 meter above the ground. The E-field is measured with a shielded loop antenna connected to a measurement receiver. Detected E-field was maximized by rotating the EUT through 360° and adjusting the receiving antenna polarizations. The maximization processes were repeated with the EUT positioned respectively in its three orthogonal axes. The measurements were performed with the peak detector and if required, the quasi-peak detector.

The measurement bandwidth is:

**Table B-1: Measurement bandwidth**

Frequency of Emission (MHz)	RBW/VBW
12.56-14.56	10/30 kHz

The E-field measured at 3m is calculated as:

$$\text{E-field (dB}\mu\text{V/m)} = \text{Rx (dB}\mu\text{V)} + \text{Cable Loss (dB)} + \text{AF@3m (dB/m)}$$

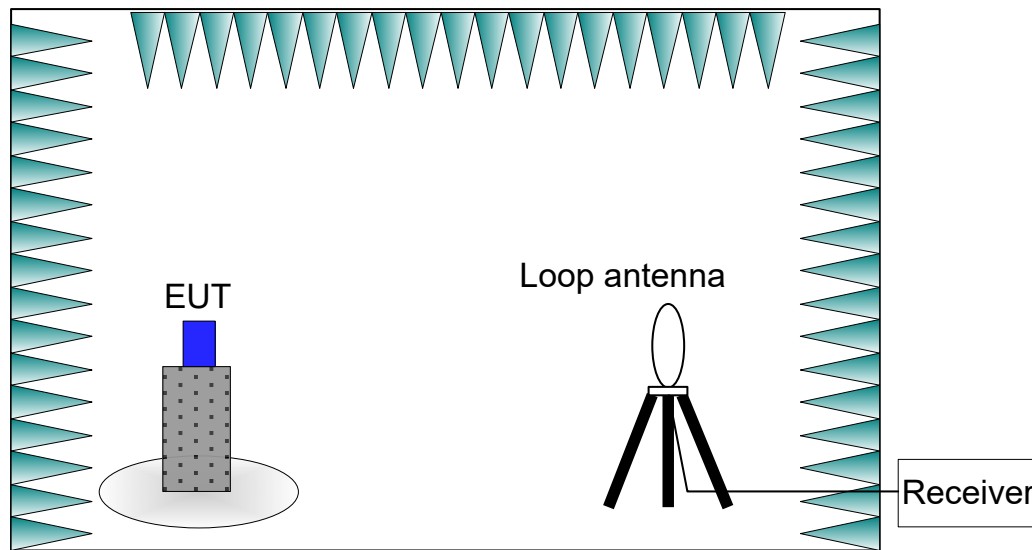

**Figure B-1: Measurement Setup**

### B.1.3. EUT Operating Mode and Test Conditions

The measurement of EUT is carried out under the transmit state of NFC(See 3.4).

The EUT is powered by a travel adapter.

All possible configurations were investigated and only the worst case is reported.

During the measurements, the ambient temperature of the electromagnetic anechoic chamber is in the range of 15 ~ 25 °C.

### B.1.4. Limits

**Table B-2: Limits**

Frequency Range (MHz)	E-field Strength Limit @ 30 m ( $\mu\text{V/m}$ )	E-field Strength Limit @ 3 m ( $\text{dB}\mu\text{V/m}$ )
13.560 $\pm$ 0.007	+15,848	124
13.410 to 13.553 13.567 to 13.710	+334	90
13.110 to 13.410 13.710 to 14.010	+106	81



Note: Where the limits have been defined at one distance, and a signal level measured at another, the limits have been extrapolated using the following formula:

$$\text{Extrapolation(dB)} = 40\log_{10}(\text{Measurement Distance}/\text{Specification Distance})$$

### B.1.5. Measurement Results

Measurement results of normal conditions see Figure B-2 for different set-ups of EUT. The results displayed take into account applicable antenna factors and cable losses.

**Conclusions:** Set.NFC02, **PASS.**

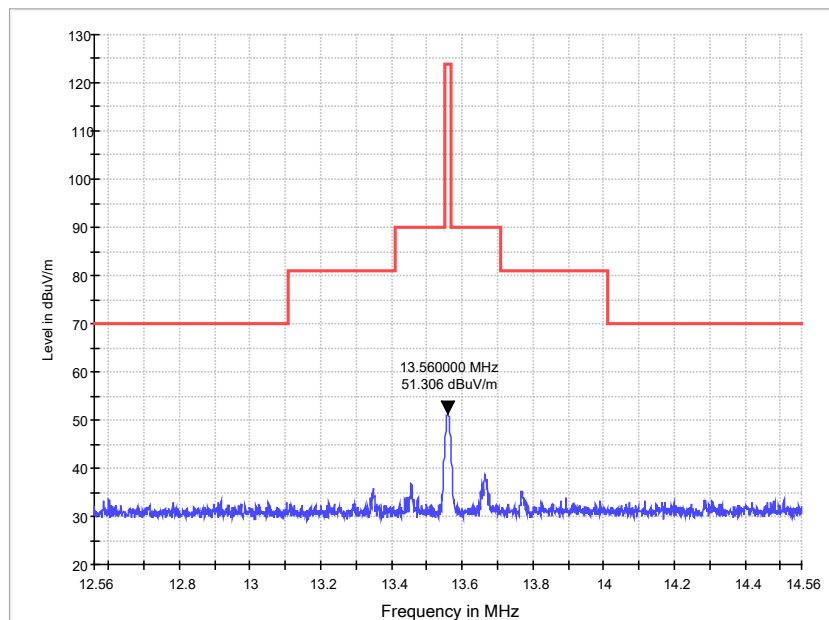

**Figure B-2: Measurement results for Electric Field Strength of Fundamental and Outside the Allocated bands**

## **B.2. Electric Field Radiated Emissions (< 30MHz)**

### **B.2.1. Reference**

See Clause 6.4 of ANSI C63.10-2013 specifically.

See Clause 4 and Clause 5 of ANSI C63.10-2013 generally.

### **B.2.2. Measurement Methods**

The transmitter carrier output levels (E-Field) from the EUT are measured in a semi-anechoic

chamber. The EUT is placed on a non-conductive stand of 80cm high, and at a measurement distance of 3m from the receiving antenna. The center of the receiving loop antenna is 1.0 meter above the ground. The E-field is measured with a shielded loop antenna connected to a measurement receiver. Detected E-field was maximized by rotating the EUT through 360° and adjusting the receiving antenna polarizations. The maximization processes were repeated with the EUT positioned respectively in its three orthogonal axes. The measurements were performed with the peak detector and if required, the quasi-peak detector.

The measurement bandwidth is:

**Table B-3: Measurement bandwidth**

Frequency of Emission (MHz)	RBW/VBW
0.009-0.15	100/300 Hz
0.15-30	10/30 kHz

The E-field measured at 3m is calculated as:

$$\text{E-field (dB}\mu\text{V/m)} = \text{Rx (dB}\mu\text{V)} + \text{Cable Loss (dB)} + \text{AF@3m (dB/m)}$$

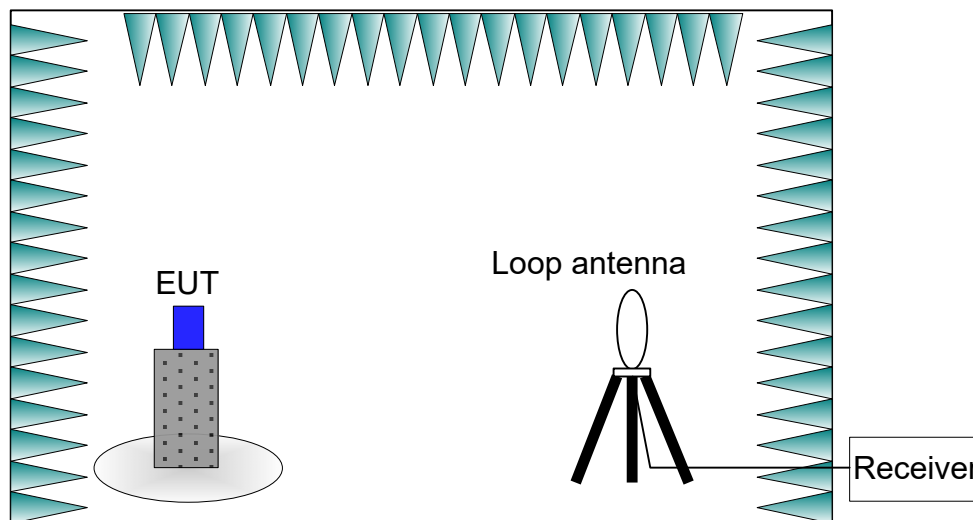

**Figure B-3: Measurement Setup**

### B.2.3. EUT Operating Mode and Test Conditions

The measurement of EUT is carried out under the transmit state of NFC(See 3.4).

The EUT is powered by a travel adapter.

All possible configurations were investigated and only the worst case is reported.

During the measurements, the ambient temperature of the electromagnetic anechoic chamber is in the range of 15 ~ 25 °C.

#### B.2.4. Limits

Table B-4: Limits

Frequency Range (MHz)	E-field Strength Limit @ 30m (mV/m)	E-field Strength Limit @ 3m (dB $\mu$ V/m)
0.009-0.490	2400/F(kHz)	129-94
0.490-1.705	24000/F(kHz)	74-63
1.705-30	30	70

Note: Where the limits have been defined at one distance, and a signal level measured at another, the limits have been extrapolated using the following formula:  
Extrapolation(dB) =  $40\log_{10}(\text{Measurement Distance}/\text{Specification Distance})$

#### B.2.5. Measurement Results

Measurement results of normal conditions see Figure B-4 for different set-ups of EUT. The results displayed take into account applicable antenna factors and cable losses.

**Conclusions:** Set.NFC01, **PASS**.

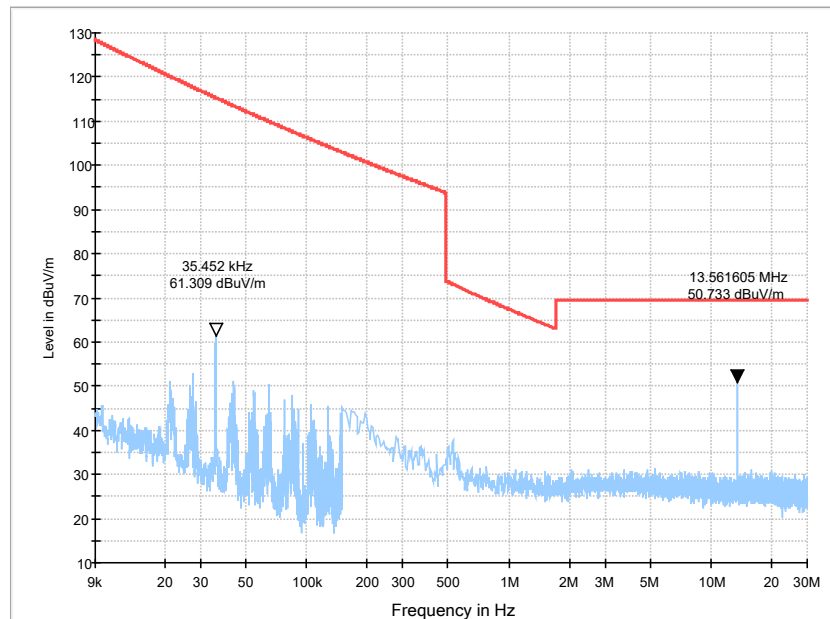

**Figure B-4: Measurement results for Electric Field Radiated Emissions (< 30MHz)**

### **B.3. Electric Field Radiated Emissions ( $\geq 30\text{MHz}$ )**

#### **B.3.1. Reference**

See Clause 6.5 of ANSI C63.10-2013 specifically.

See Clause 4 and Clause 5 of ANSI C63.10-2013 generally.

#### **B.3.2. Measurement Methods**

The electric field radiated emissions from the EUT are measured in a semi-anechoic chamber. The EUT is placed on a non-conductive stand of 80cm high, and at a measurement distance of 3m from the receiving antenna. The receiving antennas connected to a measurement receiver. In order to search for maximum field strength emitted from the EUT, the receiving antenna can be moved between the height of 1.0 m to 4.0 m. Detected E-field was maximized at each frequency by rotating the EUT through 360° and adjusting the receiving antenna positions for both vertical and horizontal antenna polarizations. The maximization processes were repeated with the EUT positioned respectively in its three orthogonal axes. The measurements were performed with the peak detector and if required, the quasi-peak detector.

The measurement bandwidth is:

**Table B-5: Measurement bandwidth**

Frequency of Emission (MHz)	RBW/VBW
30-1000	120kHz

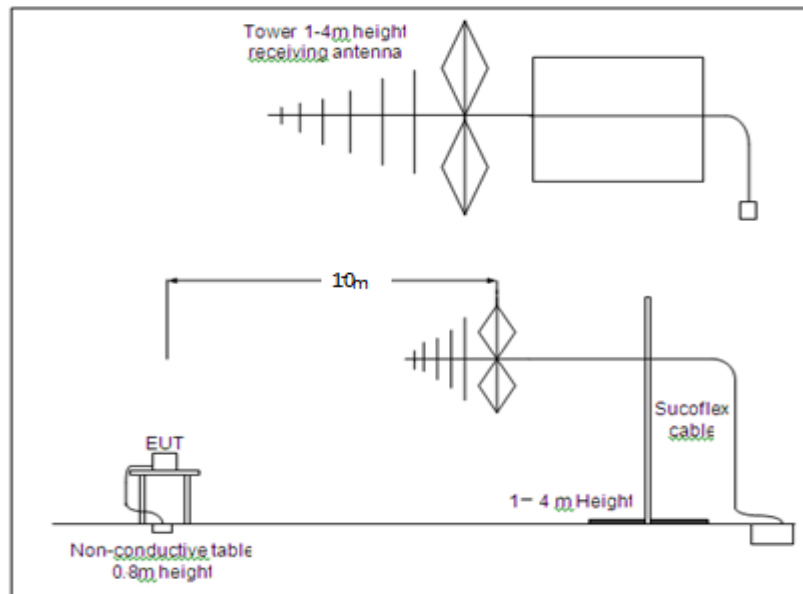

**Figure B-5: Measurement Setup**

### B.3.3. EUT Operating Mode and Test Conditions

The measurement of EUT is carried out under the transmit state of NFC(See 3.4).

The EUT had been connected to a travel adapter.

All possible configurations were investigated and only the worst case is reported.

During the measurements, the ambient temperature of the electromagnetic anechoic chamber is in the range of 15 ~ 25 °C.

### B.3.4. Limits

**Table B-6: Limits**

Frequency Range (MHz)	E-field Strength Limit @ 3m (mV/m)	E-field Strength Limit @ 3m (dBμV/m)	E-field Strength Limit @ 10m (dBμV/m)
30-88	100	40	30

88-216	150	43.5	33.5
216-960	200	46	36
960-1000	500	54	44

### B.3.5. Measurement Results

A "reference path loss" is established and the ARpl is the attenuation of "reference path loss". It includes the antenna factor of receive antenna and the path loss.

The measurement results are obtained as described below:

Measurement Result = Receiver Reading + Antenna Factor + Cable loss

Measurement results of normal conditions see Figure B-6 for different set-ups of EUT. The results displayed take into account applicable antenna factors and cable losses.

**Conclusions:** Set.NFC01, **PASS.**

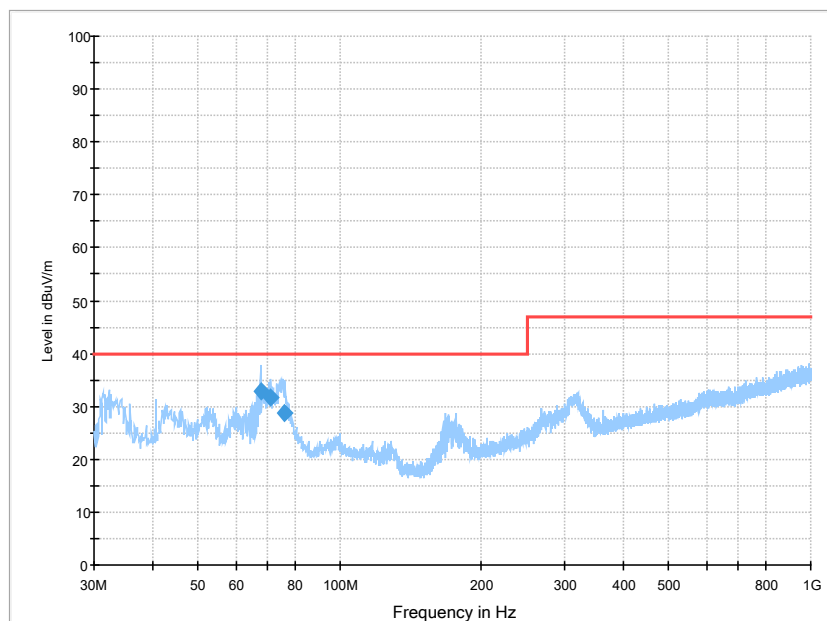

**Figure B-6: Measurement results for Electric Field Radiated Emissions (≥30MHz)**

### Final\_Result

Frequency (MHz)	QuasiPeak (dBuV/m)	Height (cm)	Polarization	Azimuth (deg)	Corr. (dB)	Margin (dB)	Limit (dBuV/m)
67.733000	32.8	100.0	V	240.0	-3.7	7.2	40.0
71.322000	31.7	125.0	V	194.0	-4.8	8.3	40.0
76.075000	28.7	125.0	V	195.0	-5.9	11.3	40.0

## **B.4. Frequency Tolerance**

### **B.4.1. Reference**

See Clause 6.8 of ANSI C63.10-2013 specifically.

See Clause 4 and Clause 5 of ANSI C63.10-2013 generally.

### **B.4.2. Measurement Methods**

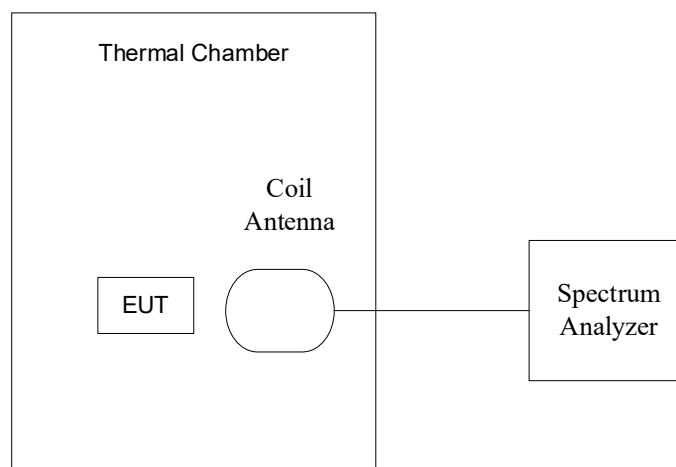

**Figure B-7: Measurement Setup**

The transmitter output signal was picked up by coil antenna connected to the spectrum analyzer. The center frequency was measured with 30Hz RBW and 1kHz span.

During the test, the EUT was placed in a thermal chamber until thermal balance and lasting appropriate time.

### **B.4.3. EUT Operating Mode and Test Conditions**

The measurement of EUT was carried out under the transmit state of without modulation(See 3.4).

EUT had not been connected to a travel adapter. The frequency stability was measured with the different voltage and temperature combinations:

- a) The nominal voltage 3.8V(See 3.1)was used and the temperature was varied from -20°C to +50°C in 10°C increments using an environmental chamber.
- b) The 20°C was used and the voltages were 3.65V, 3.8V and 4.2V (The extreme low voltage , the nominal voltage and the extreme high voltage defined in section 3.1).

The details were as following:

**Table B-7: Combinations of Voltage and Temperature**

Test items	Voltage	Temperature
Frequency stability with respect to ambient temperature	3.8V	-20°C
		-10°C
		0°C
		10°C
		20°C
		30°C
		40°C
		50°C
Frequency stability when varying supply voltage	3.65V	20°C
	3.8V	
	4.2V	

#### B.4.4. Test Layouts

See B.4.2.

#### B.4.5. Limits

The frequency tolerance of the carrier signal shall be maintained within +/- 0.01% of the operating frequency.

#### B.4.6. Measurement Results

Measurement results see Table B-8 for different test conditions.

**Conclusions:** Set.NFC03, **PASS.**



**Table B-8: Measurement results for Frequency Tolerance**

Temperature	Voltage	Frequency (MHz)			
		Startup	2 Min Later	5 Min Later	10 Min Later
-20°C	3.8V	13.560071250	13.560070625	13.560065625	13.560063125
-10°C	3.8V	13.560071875	13.560070625	13.560069375	13.560068125
0°C	3.8V	13.560068125	13.560066875	13.560065625	13.560643750
10°C	3.8V	13.560043125	13.560041875	13.560040625	13.560038125
20°C	3.8V	13.560028125	13.560020625	13.560019375	13.560018750
30°C	3.8V	13.559970625	13.559969375	13.559965625	13.559964375
40°C	3.8V	13.559949375	13.559939375	13.559926875	13.559925625
50°C	3.8V	13.559914375	13.559910625	13.559909375	13.559906875
20°C	3.65V	13.559956875	13.559969375	13.559975625	13.559986875
20°C	4.2V	13.559958125	13.559970625	13.559983125	13.559989375

Temperature	Voltage	Frequency Error (%)			
		Startup	2 Min Later	5 Min Later	10 Min Later
-20°C	3.8V	0.001	0.001	0.001	0.001
-10°C	3.8V	0.001	0.001	0.001	0.001
0°C	3.8V	0.001	0.001	0.001	0.001
10°C	3.8V	0.000	0.000	0.000	0.000
20°C	3.8V	0.000	0.000	0.000	0.000
30°C	3.8V	0.000	0.000	0.000	0.000
40°C	3.8V	0.000	0.000	0.000	0.000
50°C	3.8V	-0.001	-0.001	-0.001	-0.001
20°C	3.65V	0.000	0.000	0.000	0.000
20°C	4.2V	0.000	0.000	0.000	0.000

#### **B.4.7. Measurement Uncertainty**

Measurement uncertainty:  $U = 77 \text{ Hz}$ ,  $k=2$

### **B.5. 20dB Bandwidth**

#### **B.5.1. Reference**

See Clause 6.9 of ANSI C63.10-2013 specifically.

See Clause 4 and Clause 5 of ANSI C63.10-2013 generally.

#### **B.5.2. Measurement Methods**

The transmitter output signal was picked up by coil antenna connected to the spectrum analyzer. The bandwidth of the center frequency was measured with 140Hz RBW, 420Hz VBW and 14kHz span.

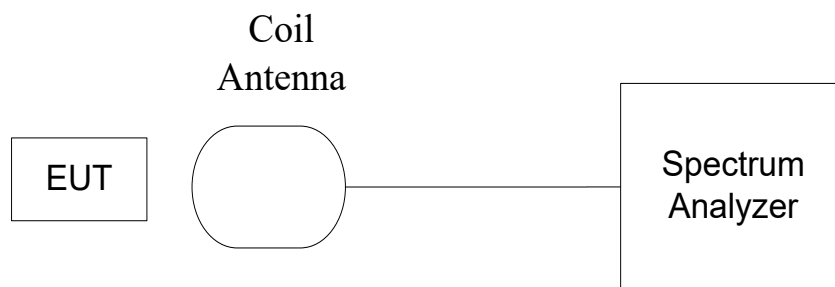

**Figure B-8: Measurement Setup**

#### **B.5.3. EUT Operating Mode and Test Conditions**

The measurement of EUT was carried out under the transmit state of NFC (See 3.4).

EUT had not been connected to a travel adapter.

During the measurements, the ambient temperature was in the range of 15 ~ 25 °C.

#### **B.5.4. Test Layouts**

See B.5.2.

### B.5.5. Limits

The 20dB bandwidth shall be less than 80% of the permitted frequency band. For 13.56 MHz NFC, the permitted frequency band is 14kHz, so the limit is 11.2 kHz.

### B.5.6. Measurement Results

Measurement results see Figure B-9.

**Conclusions:** Set.NFC03, **PASS**.

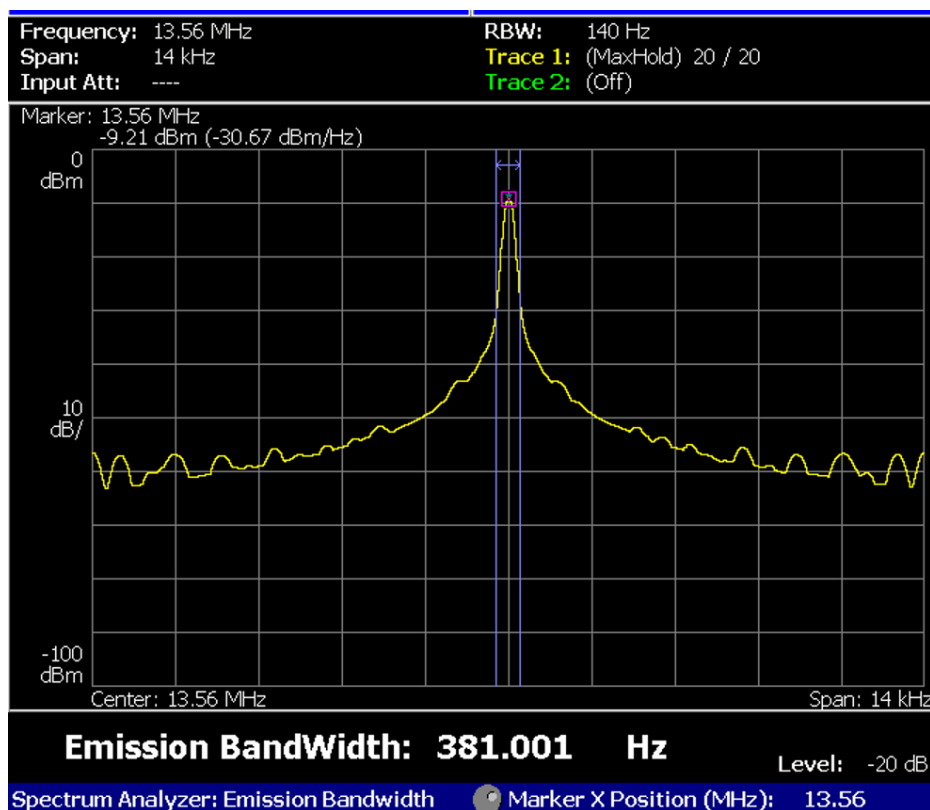

Figure B-9: Measurement results for 20dB Bandwidth

### B.5.7. Measurement Uncertainty

Measurement uncertainty:  $U = 77$  Hz,  $k=2$

## B.6. Conducted emission

### B.6.1. Reference

See Clause 6.2 of ANSI C63.10-2013 specifically.

See Clause 4 and Clause 5 of ANSI C63.10-2013 generally.

### B.6.2. Measurement Methods

The conducted emissions from the AC port of the EUT are measured in a shielding room. The EUT is connected to a Line Impedance Stabilization Network (LISN). An overview sweep with peak detection was performed. The measurements were performed with a quasi-peak detector and if required, an average detector.

The conducted emission measurements were made with the following detector of the test receiver:

Quasi-Peak / Average Detector.

The measurement bandwidth is:

**Table B-9: Measurement Bandwidth**

Frequency of Emission (MHz)	RBW/VBW
0.15-30	9kHz

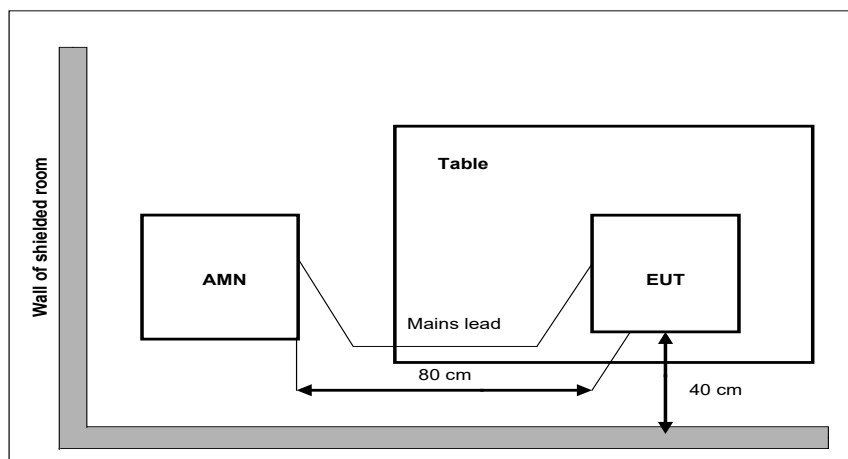

**Figure B-10: Measurement Setup**

### B.6.3. EUT Operating Mode and Test Conditions

The measurement of EUT is carried out under the transmit state of NFC(See 3.4).

The EUT is powered by a travel adapter.

All possible configurations were investigated and only the worst case is reported.

During the measurements, the ambient temperature is in the range of 15 ~ 25 °C.

### B.6.4. Limits

Table B-10: Limits

Frequency range (MHz)	Quasi-peak Limit (dB $\mu$ V)	Average Limit (dB $\mu$ V)
0.15 to 0.5	66 to 56	56 to 46
0.5 to 5	56	46
5 to 30	60	50

### B.6.5. Measurement Results

Measurement Result = Receiver Reading + Voltage deviation factor + Cable loss

Measurement results see Figure B-11.

Conclusions: Set.NFC01, **PASS**.

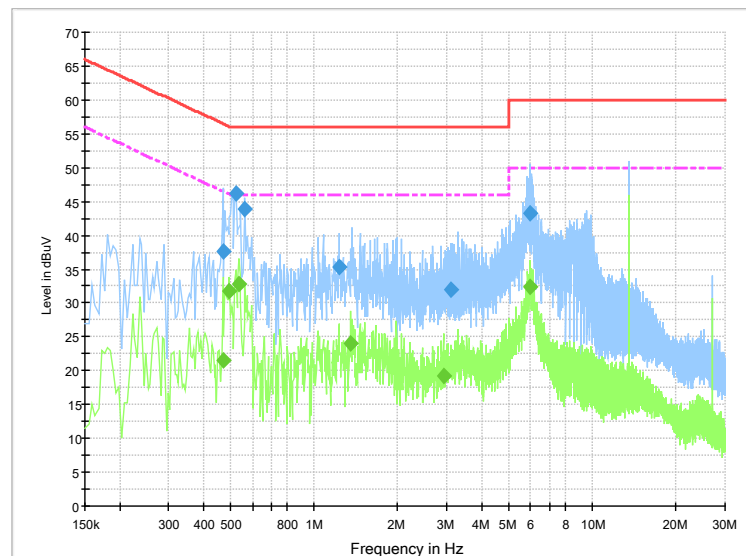

Figure B-11: Measurement results for Conducted Emission(NFC01-2)

### Final Result 1

Frequency (MHz)	QuasiPeak (dBuV)	Meas. Time	Bandwidth (kHz)	Filter	Line	Corr. (dB)	Margin (dB)	Limit (dBuV)
0.469500	37.6	5000.0	9.000	On	N	19.8	19.0	56.5
0.523500	46.2	5000.0	9.000	On	L1	19.8	9.8	56.0
0.564000	43.9	5000.0	9.000	On	L1	19.8	12.1	56.0
1.230000	35.4	5000.0	9.000	On	L1	19.7	20.6	56.0
3.106500	32.0	5000.0	9.000	On	L1	19.7	24.0	56.0
5.982000	43.3	5000.0	9.000	On	L1	19.7	16.7	60.0

## Final Result 2

Frequency (MHz)	Average (dBuV)	Meas. Time	Bandwidth (kHz)	Filter	Line	Corr. (dB)	Margin (dB)	Limit (dBuV)
0.469500	21.5	5000.0	9.000	On	N	19.8	25.1	46.5
0.496500	31.8	5000.0	9.000	On	N	19.8	14.3	46.1
0.537000	32.8	5000.0	9.000	On	N	19.8	13.2	46.0
1.351500	24.1	5000.0	9.000	On	N	19.6	21.9	46.0
2.913000	19.2	5000.0	9.000	On	L1	19.7	26.8	46.0
5.986500	32.4	5000.0	9.000	On	L1	19.7	17.6	50.0

## **ANNEX C: Persons involved in this testing**

**Table C-1: Persons involved**

<b>Test Item</b>	<b>Tester</b>
20dB Bandwidth	Zhou Bin
Frequency Tolerance	Zhou Bin
Electric Field Strength of Fundamental and Outside the Allocated bands	Li Zongliang
Electric Field Radiated Emissions (< 30MHz)	Li Zongliang
Electric Field Radiated Emissions (≥30MHz)	Li Zongliang
Conducted Emissions	Guo Qian

## ANNEX D: Accreditation Certificate

<p>United States Department of Commerce National Institute of Standards and Technology</p>  	
<hr/> <b>Certificate of Accreditation to ISO/IEC 17025:2017</b> <hr/>	
NVLAP LAB CODE: 600118-0	
<b>Telecommunication Technology Labs, CAICT</b> Beijing China	
<i>is accredited by the National Voluntary Laboratory Accreditation Program for specific services, listed on the Scope of Accreditation, for:</i>	
<b>Electromagnetic Compatibility &amp; Telecommunications</b>	
<i>This laboratory is accredited in accordance with the recognized International Standard ISO/IEC 17025:2017. This accreditation demonstrates technical competence for a defined scope and the operation of a laboratory quality management system (refer to joint ISO-ILAC-IAF Communique dated January 2009).</i>	
<hr/> 2020-09-29 through 2021-09-30 Effective Dates	 For the National Voluntary Laboratory Accreditation Program

\*\*\*END OF REPORT\*\*\*