



FCC RF Test Report

APPLICANT : HMD Global Oy
EQUIPMENT : Smart Phone
BRAND NAME : NOKIA
MODEL NAME : TA-1243, TA-1251
FCC ID : 2AJOTTA-1243
STANDARD : 47 CFR Part 2, 22, 24, 27
CLASSIFICATION : PCS Licensed Transmitter Held to Ear (PCE)

The product was received on May 12, 2020 and completely tested on Aug. 11, 2020. We, Sporton International (Kunshan) Inc., would like to declare that the tested sample has been evaluated in accordance with the procedures given in ANSI C63.26-2015 and shown compliance with the applicable technical standards.

The test results in this report apply exclusively to the tested model / sample. Without written approval of Sporton International (Kunshan) Inc., the test report shall not be reproduced except in full.

Reviewed by: Jason Jia / Supervisor

Approved by: James Huang / Manager



Sporton International (Kunshan) Inc.

**No. 1098, Pengxi North Road, Kunshan Economic Development Zone Jiangsu Province 215300
People's Republic of China**



TABLE OF CONTENTS

REVISION HISTORY... 3
SUMMARY OF TEST RESULT ... 4
1 GENERAL DESCRIPTION ... 5
1.1 Applicant ... 5
1.2 Manufacturer ... 5
1.3 Product Feature of Equipment Under Test ... 5
1.4 Product Specification of Equipment Under Test ... 6
1.5 Modification of EUT ... 6
1.6 Maximum ERP/EIRP Power, Frequency Tolerance, and Emission Designator ... 7
1.7 Testing Location ... 13
1.8 Test Software ... 13
1.9 Applicable Standards ... 13
2 TEST CONFIGURATION OF EQUIPMENT UNDER TEST ... 14
2.1 Test Mode ... 14
2.2 Connection Diagram of Test System ... 16
2.3 Support Unit used in test configuration and system ... 17
2.4 Measurement Results Explanation Example ... 17
2.5 Frequency List of Low/Middle/High Channels ... 18
3 CONDUCTED TEST ITEMS ... 21
3.1 Measuring Instruments ... 21
3.2 Test Setup ... 21
3.3 Test Result of Conducted Test ... 21
3.4 Conducted Output Power and ERP/EIRP ... 22
3.5 Peak-to-Average Ratio ... 23
3.6 Occupied Bandwidth ... 24
3.7 Conducted Band Edge ... 25
3.8 Conducted Spurious Emission ... 27
3.9 Frequency Stability ... 28
4 RADIATED TEST ITEMS ... 29
4.1 Measuring Instruments ... 29
4.2 Test Setup ... 29
4.3 Test Result of Radiated Test ... 29
4.4 Radiated Spurious Emission ... 30
5 LIST OF MEASURING EQUIPMENT ... 31
6 UNCERTAINTY OF EVALUATION ... 32
APPENDIX A. TEST RESULTS OF CONDUCTED TEST
APPENDIX B. TEST RESULTS OF RADIATED TEST
APPENDIX C. TEST SETUP PHOTOGRAPHS



SUMMARY OF TEST RESULT

Report Section	FCC Rule	Description	Limit	Result	Remark
3.4	§2.1046	Conducted Output Power	Reporting Only	PASS	-
	§22.913(a)(5)	Effective Radiated Power (5G NR n5)	ERP < 7 Watt		
	§27.50(c)(10)	Effective Radiated Power (5G NR n71)	ERP < 3 Watt		
	§24.232(c) §27.50(h)(2)	Equivalent Isotropic Radiated Power (5G NR n2) (5G NR n38) (5G NR n41)	EIRP < 2Watt		
	§27.50(d)(4)	Equivalent Isotropic Radiated Power (5G NR n66)	EIRP < 1Watt		
3.5	§24.232(d)	Peak-to-Average Ratio	<13 dB	PASS	-
3.6	§2.1049	Occupied Bandwidth	Reporting Only	PASS	-
3.7	§2.1051 §22.917(a) §24.238(a) §27.53(g)	Conducted Band Edge Measurement (5G NR n2) (5G NR n5) (5G NR n66) (5G NR n71)	< 43+10log ₁₀ (P[Watts])	PASS	-
	§27.53(m)(4)	Conducted Band Edge Measurement (5G NR n38) (5G NR n41)	§27.53(m)(4)		
3.8	§2.1051 §22.917(a) §24.238(a) §27.53(g)	Conducted Spurious Emission (5G NR n2) (5G NR n5) (5G NR n66) (5G NR n71)	< 43+10log ₁₀ (P[Watts])	PASS	-
	§2.1051 §27.53(m)(4)	Conducted Spurious Emission (5G NR n38) (5G NR n41)	< 55+10log ₁₀ (P[Watts])		
3.9	§2.1055 §22.355	Frequency Stability Temperature & Voltage	< 2.5 ppm for Part 22	PASS	-
	§2.1055 §24.235 §27.54		Within Authorized Band		
4.4	§2.1053 §22.917(a) §24.238(a) §27.53(g)	Radiated Spurious Emission (5G NR n2) (5G NR n5) (5G NR n66) (5G NR n71)	< 43+10log ₁₀ (P[Watts])	PASS	Under limit 32.45 dB at 10340.000 MHz
	§2.1053 §27.53(m)(4)	Radiated Spurious Emission (5G NR n38) (5G NR n41)	< 55+10log ₁₀ (P[Watts])		



1 General Description

1.1 Applicant

HMD Global Oy
Bertel Jungin aukio 9, 02600 Espoo, Finland

1.2 Manufacturer

HMD Global Oy
Bertel Jungin aukio 9, 02600 Espoo, Finland

1.3 Product Feature of Equipment Under Test

Product Feature	
Equipment	Smart Phone
Brand Name	NOKIA
Model Name	TA-1243, TA-1251
FCC ID	2AJOTTA-1243
EUT supports Radios application	GSM/WCDMA/LTE/5G NR/NFC WLAN 2.4GHz 802.11b/g/n HT20 WLAN 5GHz 802.11a/n HT20/HT40 WLAN 5GHz 802.11ac VHT20/VHT40/VHT80 Bluetooth BR/EDR/LE FM Receiver and GNSS
IMEI Code	Conducted : N/A Radiation : 353137110023325/353137110023333
HW Version	HW03
SW Version	00WW_0_180
EUT Stage	Identical Prototype

Remark:

1. Only 5G NR bands are tested in this report, all the other RF bands are tested in the other reports separately.
2. 5G NR n2/n41 supports SA and NSA mode, other 5G NR supports NSA mode only. According to the maximum power between SA and NSA mode, SA covers NSA mode, we choose SA mode to test all test items of 5G NR n2/n41. For NSA mode of 5G NR n5/n38/n66/n71, we only show the combination of the maximum power among all EN-DC combinations in the report.
3. 5G NR supports CP-OFDM and DFT-s-OFDM modulation, DFT-s-OFDM power is higher than CP-OFDM, so only DFT-s-OFDM modulation is perform for all test.
4. 5G NR n41 supports HPUE.



1.4 Product Specification of Equipment Under Test

Standards-related Product Specification	
Tx Frequency	5G NR n2: 1852.5 MHz ~ 1907.5 MHz 5G NR n5: 826.5 MHz ~ 846.5 MHz 5G NR n38 : 2580MHz ~ 2610MHz 5G NR n41: 2506.02 MHz ~ 2679.99 MHz 5G NR n66: 1712.5 MHz ~ 1777.5 MHz 5G NR n71: 665.5 MHz ~ 695.5MHz
Rx Frequency	5G NR n2: 1932.5 MHz ~ 1987.5 MHz 5G NR n5: 871.5 MHz ~ 891.5 MHz 5G NR n38 : 2580MHz ~ 2610MHz 5G NR n41: 2506.02 MHz ~ 2679.99 MHz 5G NR n66: 2112.5 MHz~ 2197.5 MHz 5G NR n71: 619.5 MHz ~ 649.5MHz
Bandwidth	n2, n5, n66, n71: 5MHz / 10MHz / 15MHz / 20MHz n38 : 20MHz n41 : 20MHz / 40MHz / 50MHz / 60MHz / 80MHz / 90MHz / 100MHz
SCS	FDD: 15KHz TDD: 30KHz
Antenna Gain	n2 / n5 : -1.10 dBi n38 / n41 : -0.30 dBi n66 : -2.50 dBi n71 : -3.70 dBi
Type of Modulation	CP-OFDM: QPSK / 16QAM / 64QAM / 256QAM DFT-s-OFDM: PI/2 BPSK / QPSK / 16QAM / 64QAM / 256QAM

1.5 Modification of EUT

No modifications are made to the EUT during all test items.



1.6 Maximum ERP/EIRP Power, Frequency Tolerance, and Emission Designator

5G NR n2		PI/2 BPSK		QPSK	
BW (MHz)	Frequency Range (MHz)	Emission Designator (99%OBW)	Maximum EIRP(W)	Emission Designator (99%OBW)	Maximum EIRP(W)
5	1852.5 ~ 1907.5	4M50F9W	0.1892	4M50G7D	0.1875
10	1855.0 ~ 1905.0	9M09F9W	0.1950	9M05G7D	0.1897
15	1857.5 ~ 1902.5	13M5F9W	0.1991	13M5G7D	0.1950
20	1860.0 ~ 1900.0	18M6F9W	0.2023	18M3G7D	0.1945
Frequency Tolerance (ppm)		0.0020			

5G NR n2		16QAM		64QAM	
BW (MHz)	Frequency Range (MHz)	Emission Designator (99%OBW)	Maximum EIRP(W)	Emission Designator (99%OBW)	Maximum EIRP(W)
5	1852.5 ~ 1907.5	4M50W7D	0.1489	4M54W7D	0.1057
10	1855.0 ~ 1905.0	9M05W7D	0.1496	9M01W7D	0.1069
15	1857.5 ~ 1902.5	13M5W7D	0.1545	13M5W7D	0.1114
20	1860.0 ~ 1900.0	18M6W7D	0.1459	18M3W7D	0.1086
Frequency Tolerance (ppm)		-			

5G NR n2		256QAM	
BW (MHz)	Frequency Range (MHz)	Emission Designator (99%OBW)	Maximum EIRP(W)
5	1852.5 ~ 1907.5	4M51W7D	0.0647
10	1855.0 ~ 1905.0	9M07W7D	0.0656
15	1857.5 ~ 1902.5	13M5W7D	0.0681
20	1860.0 ~ 1900.0	18M5W7D	0.0681
Frequency Tolerance (ppm)		-	



5G NR n5 (EN DC_7A-n5A)		PI/2 BPSK		QPSK	
BW (MHz)	Frequency Range (MHz)	Emission Designator (99%OBW)	Maximum EIRP(W)	Emission Designator (99%OBW)	Maximum EIRP(W)
5	826.5 ~ 846.5	4M48F9W	0.1069	4M51G7D	0.1045
10	829.0 ~ 844.0	9M07F9W	0.1072	9M03G7D	0.1054
15	831.5 ~ 841.5	13M5F9W	0.1064	13M5G7D	0.1045
20	834.0 ~ 839.0	18M4F9W	0.1107	18M3G7D	0.1072
Frequency Tolerance (ppm)		0.0048			

5G NR n5 (EN DC_7A-n5A)		16QAM		64QAM	
BW (MHz)	Frequency Range (MHz)	Emission Designator (99%OBW)	Maximum EIRP(W)	Emission Designator (99%OBW)	Maximum EIRP(W)
5	826.5 ~ 846.5	4M50W7D	0.0853	4M53W7D	0.0597
10	829.0 ~ 844.0	9M05W7D	0.0854	9M05W7D	0.0589
15	831.5 ~ 841.5	13M5W7D	0.0843	13M5W7D	0.0607
20	834.0 ~ 839.0	18M3W7D	0.0838	18M3W7D	0.0594
Frequency Tolerance (ppm)		-			

5G NR n5 (EN DC_7A-n5A)		256QAM	
BW (MHz)	Frequency Range (MHz)	Emission Designator (99%OBW)	Maximum EIRP(W)
5	826.5 ~ 846.5	4M49W7D	0.0373
10	829.0 ~ 844.0	9M05W7D	0.0372
15	831.5 ~ 841.5	13M5W7D	0.0377
20	834.0 ~ 839.0	18M4W7D	0.0368
Frequency Tolerance (ppm)		-	



5G NR n38 (EN DC_71A-n38A)		PI/2 BPSK		QPSK	
BW (MHz)	Frequency Range (MHz)	Emission Designator (99%OBW)	Maximum EIRP(W)	Emission Designator (99%OBW)	Maximum EIRP(W)
20	2580.00 ~ 2610.00	18M7F9W	0.2203	18M6G7D	0.2173
Frequency Tolerance (ppm)		0.0032			

5G NR n38 (EN DC_71A-n38A)		16QAM		64QAM	
BW (MHz)	Frequency Range (MHz)	Emission Designator (99%OBW)	Maximum EIRP(W)	Emission Designator (99%OBW)	Maximum EIRP(W)
20	2580.00 ~ 2610.00	18M4W7D	0.1774	18M3W7D	0.1253
Frequency Tolerance (ppm)		-			

5G NR n38 (EN DC_7A-n5A)		256QAM			
BW (MHz)	Frequency Range (MHz)	Emission Designator (99%OBW)		Maximum EIRP(W)	
20	2580.00 ~ 2610.00	18M5W7D		0.1233	
Frequency Tolerance (ppm)		-			

5G NR n41		PI/2 BPSK		QPSK	
BW (MHz)	Frequency Range (MHz)	Emission Designator (99%OBW)	Maximum EIRP(W)	Emission Designator (99%OBW)	Maximum EIRP(W)
20	2506.02 ~ 2679.99	18M7F9W	0.2655	18M6G7D	0.2704
40	2516.01 ~ 2670.00	36M1F9W	0.2831	36M0G7D	0.2999
50	2521.02 ~ 2664.99	45M9F9W	0.2698	46M0G7D	0.2742
60	2526.00 ~ 2659.98	58M6F9W	0.2972	58M7G7D	0.3020
80	2536.02 ~ 2649.99	77M5F9W	0.2831	88M9G7D	0.2799
90	2541.00 ~ 2644.98	86M7F9W	0.2825	98M3G7D	0.2938
100	2546.01 ~ 2640.00	96M7F9W	0.2704	96M9G7D	0.2897
Frequency Tolerance (ppm)		0.0026			



5G NR n41		16QAM		64QAM	
BW (MHz)	Frequency Range (MHz)	Emission Designator (99%OBW)	Maximum EIRP(W)	Emission Designator (99%OBW)	Maximum EIRP(W)
20	2506.02 ~ 2679.99	18M5W7D	0.2618	18M5W7D	0.2547
40	2516.01 ~ 2670.00	36M0W7D	0.2825	36M0W7D	0.2301
50	2521.02 ~ 2664.99	45M9W7D	0.2466	46M0W7D	0.2153
60	2526.00 ~ 2659.98	59M1W7D	0.2858	58M9W7D	0.2518
80	2536.02 ~ 2649.99	77M5W7D	0.2754	77M8W7D	0.2564
90	2541.00 ~ 2644.98	87M0W7D	0.2673	86M7W7D	0.2377
100	2546.01 ~ 2640.00	96M7W7D	0.2618	97M3W7D	0.2421
Frequency Tolerance (ppm)		-			

5G NR n41		256QAM	
BW (MHz)	Frequency Range (MHz)	Emission Designator (99%OBW)	Maximum EIRP(W)
20	2506.02 ~ 2679.99	18M4W7D	0.1500
40	2516.01 ~ 2670.00	35M9W7D	0.1500
50	2521.02 ~ 2664.99	46M0W7D	0.1466
60	2526.00 ~ 2659.98	59M0W7D	0.1578
80	2536.02 ~ 2649.99	77M4W7D	0.1469
90	2541.00 ~ 2644.98	86M7W7D	0.1462
100	2546.01 ~ 2640.00	97M1W7D	0.1439
Frequency Tolerance (ppm)		-	



5G NR n66 (EN DC_5A-n66A)		PI/2 BPSK		QPSK	
BW (MHz)	Frequency Range (MHz)	Emission Designator (99%OBW)	Maximum EIRP(W)	Emission Designator (99%OBW)	Maximum EIRP(W)
5	1712.5 ~ 1777.5	4M50F9W	0.1514	4M51G7D	0.1507
10	1715.0 ~ 1775.0	9M07F9W	0.1567	9M05G7D	0.1542
15	1717.5 ~ 1772.5	13M5F9W	0.1552	13M5G7D	0.1535
20	1720.0 ~ 1770.0	18M4F9W	0.1585	18M4G7D	0.1570
Frequency Tolerance (ppm)		0.0026			

5G NR n66 (EN DC_5A-n66A)		16QAM		64QAM	
BW (MHz)	Frequency Range (MHz)	Emission Designator (99%OBW)	Maximum EIRP(W)	Emission Designator (99%OBW)	Maximum EIRP(W)
5	1712.5 ~ 1777.5	4M51W7D	0.1355	4M53W7D	0.1028
10	1715.0 ~ 1775.0	9M05W7D	0.1393	9M07W7D	0.1035
15	1717.5 ~ 1772.5	13M5W7D	0.1349	13M5W7D	0.1062
20	1720.0 ~ 1770.0	18M4W7D	0.1393	18M3W7D	0.1067
Frequency Tolerance (ppm)		-			

5G NR n66 (EN DC_5A-n66A)		256QAM	
BW (MHz)	Frequency Range (MHz)	Emission Designator (99%OBW)	Maximum EIRP(W)
5	1712.5 ~ 1777.5	4M48W7D	0.0661
10	1715.0 ~ 1775.0	9M07W7D	0.0665
15	1717.5 ~ 1772.5	13M5W7D	0.0662
20	1720.0 ~ 1770.0	18M4W7D	0.0676
Frequency Tolerance (ppm)		-	



5G NR n71 (EN DC_66A-n71A)		PI/2 BPSK		QPSK	
BW (MHz)	Frequency Range (MHz)	Emission Designator (99%OBW)	Maximum ERP(W)	Emission Designator (99%OBW)	Maximum ERP(W)
5	665.5 ~ 695.5	4M49F9W	0.0524	4M50G7D	0.0521
10	668.0 ~ 693.0	9M07F9W	0.0526	9M03G7D	0.0524
15	670.5 ~ 690.5	13M5F9W	0.0546	13M5G7D	0.0532
20	673.0 ~ 688.0	18M3F9W	0.0553	18M6G7D	0.0541
Frequency Tolerance (ppm)		0.0032			

5G NR n71 (EN DC_66A-n71A)		16QAM		64QAM	
BW (MHz)	Frequency Range (MHz)	Emission Designator (99%OBW)	Maximum ERP(W)	Emission Designator (99%OBW)	Maximum ERP(W)
5	665.5 ~ 695.5	4M51W7D	0.0430	4M50W7D	0.0312
10	668.0 ~ 693.0	9M07W7D	0.0423	9M03W7D	0.0304
15	670.5 ~ 690.5	13M5W7D	0.0433	13M5W7D	0.0307
20	673.0 ~ 688.0	18M3W7D	0.0404	18M4W7D	0.0300
Frequency Tolerance (ppm)		-			

5G NR n71 (EN DC_66A-n71A)		256QAM	
BW (MHz)	Frequency Range (MHz)	Emission Designator (99%OBW)	Maximum EIRP(W)
5	665.5 ~ 695.5	4M50W7D	0.0200
10	668.0 ~ 693.0	9M07W7D	0.0200
15	670.5 ~ 690.5	13M5W7D	0.0204
20	673.0 ~ 688.0	18M4W7D	0.0205
Frequency Tolerance (ppm)		-	



1.7 Testing Location

Sporton International (Kunshan) Inc. is accredited to ISO/IEC 17025:2017 by American Association for Laboratory Accreditation with Certificate Number 5145.02.

Test Firm	Sporton International (Kunshan) Inc.		
Test Site Location	No. 1098, Pengxi North Road, Kunshan Economic Development Zone Jiangsu Province 215300 People's Republic of China TEL : +86-512-57900158 FAX : +86-512-57900958		
Test Site No.	Sporton Site No.	FCC Designation No.	FCC Test Firm Registration No.
	03CH04-KS TH01-KS	CN1257	314309

1.8 Test Software

Item	Site	Manufacture	Name	Version
1.	03CH04-KS	AUDIX	E3	6.2009-8-24a

1.9 Applicable Standards

According to the specifications of the manufacturer, the EUT must comply with the requirements of the following standards:

- ♦ 47 CFR Part 2, 22, 24, 27
- ♦ ANSI C63.26-2015
- ♦ FCC KDB 971168 D01 Power Meas License Digital Systems v03r01
- ♦ FCC KDB 412172 D01 Determining ERP and EIRP v01r01

Remark:

All test items were verified and recorded according to the standards and without any deviation during the test.



2 Test Configuration of Equipment Under Test

2.1 Test Mode

Antenna port conducted and radiated test items are performed according to KDB 971168 D01 Power Meas License Digital Systems v03r01 with maximum output power.

For radiated measurement, pre-scanned in three orthogonal panels, X, Y, Z. The worst cases (Y plane) were recorded in this report.

The device is investigated from 30MHz to 10 times of fundamental signal for radiated spurious emission test under different RB size/offset and modulations in exploratory test. Subsequently, only the worst case emissions are reported.

Orthogonal Planes of EUT	X Plane	Y Plane	Z Plane
			

Test Items	5G NR	Bandwidth (MHz)						Modulation				RB #			Test Channel				
		5	10	15	20	50-90	100	PI/2 BPSK	QPSK	16QAM	64QAM	256QAM	1	Half	Full	L	M	H	
Max. Output Power	n2	v	v	v	v	-	-	v	v	v	v	v	v		v	v	v	v	
	n5	v	v	v	v	-	-	v	v	v	v	v	v	v		v	v	v	v
	n38	-	-	-	v	-	-	v	v	v	v	v	v	v		v	v	v	v
	n41	-	-	-	v	v	v	v	v	v	v	v	v	v		v	v	v	v
	n66	v	v	v	v	-	-	v	v	v	v	v	v	v		v	v	v	v
	n71	v	v	v	v	-	-	v	v	v	v	v	v	v		v	v	v	v
Peak-to-Average Ratio	n2				v	-	-	v	v	v	v	v			v	v	v	v	
	n5				v	-	-	v	v	v	v	v			v	v	v	v	
	n38	-	-	-		-	-	v	v	v	v	v			v	v	v	v	
	n41	-	-	-			v	v	v	v	v	v			v	v	v	v	
	n66				v	-	-	v	v	v	v	v			v	v	v	v	
	n71				v	-	-	v	v	v	v	v			v	v	v	v	
26dB and 99% Bandwidth	n2	v	v	v	v	-	-	v	v	v	v	v			v	v	v	v	
	n5	v	v	v	v	-	-	v	v	v	v	v			v	v	v	v	
	n38	-	-	-	v	-	-	v	v	v	v	v			v	v	v	v	
	n41	-	-	-	v	v	v	v	v	v	v	v			v	v	v	v	
	n66	v	v	v	v	-	-	v	v	v	v	v			v	v	v	v	
	n71	v	v	v	v	-	-	v	v	v	v	v			v	v	v	v	



Test Items	Band	Bandwidth (MHz)						Modulation					RB #			Test Channel			
		5	10	15	20	50-90	100	PI/2 BPSK	QPSK	16QAM	64QAM	256QAM	1	Half	Full	L	M	H	
Conducted Band Edge	n2	v	v	v	v	-	-	v	v	v	v	v	v		v	v		v	
	n5	v	v	v	v	-	-	v	v	v	v	v	v		v	v		v	
	n38	-	-	-	v	-	-	v	v	v	v	v	v		v	v		v	
	n41	-	-	-	v	v	v	v	v	v	v	v	v		v	v		v	
	n66	v	v	v	v	-	-	v	v	v	v	v	v		v	v		v	
	n71	v	v	v	v	-	-	v	v	v	v	v	v		v	v		v	
Conducted Spurious Emission	n2	v	v		v	-	-	v	v	v	v	v	v			v	v	v	
	n5	v	v		v	-	-	v	v	v	v	v	v			v	v	v	
	n38	-	-	-	v	-	-	v	v	v	v	v	v			v	v	v	
	n41	-	-	-	v	v	v	v	v	v	v	v	v			v	v	v	
	n66	v	v		v	-	-	v	v	v	v	v	v			v	v	v	
	n71	v	v		v	-	-	v	v	v	v	v	v			v	v	v	
Frequency Stability	n2				v	-	-	v							v		v		
	n5				v	-	-	v							v		v		
	n38	-	-	-	v	-	-	v							v		v		
	n41	-	-	-	v			v							v		v		
	n66				v	-	-	v							v		v		
	n71				v	-	-	v							v		v		
E.R.P / E.I.R.P	n2	v	v		v	-	-	v	v	v	v	v	v		v	v	v	v	
	n5	v	v		v	-	-	v	v	v	v	v	v		v	v	v	v	
	n38	-	-	-	v	-	-	v	v	v	v	v	v		v	v	v	v	
	n41	-	-	-	v	v	v	v	v	v	v	v	v		v	v	v	v	
	n66	v	v		v	-	-	v	v	v	v	v	v		v	v	v	v	
	n71	v	v		v	-	-	v	v	v	v	v	v		v	v	v	v	
Radiated Spurious Emission	n2	Worst Case																v	
	n5	Worst Case																v	
	n38	Worst Case																v	
	n41	Worst Case																v	
	n66	Worst Case																v	
	n71	Worst Case																v	
Note	1. The mark "v" means that this configuration is chosen for testing 2. The mark "-" means that this bandwidth is not supported. 3. The device is investigated from 30MHz to 10 times of fundamental signal for radiated spurious emission test under																		

different RB size/offset and modulations in exploratory test. Subsequently, only the worst case emissions are reported.

2.2 Connection Diagram of Test System

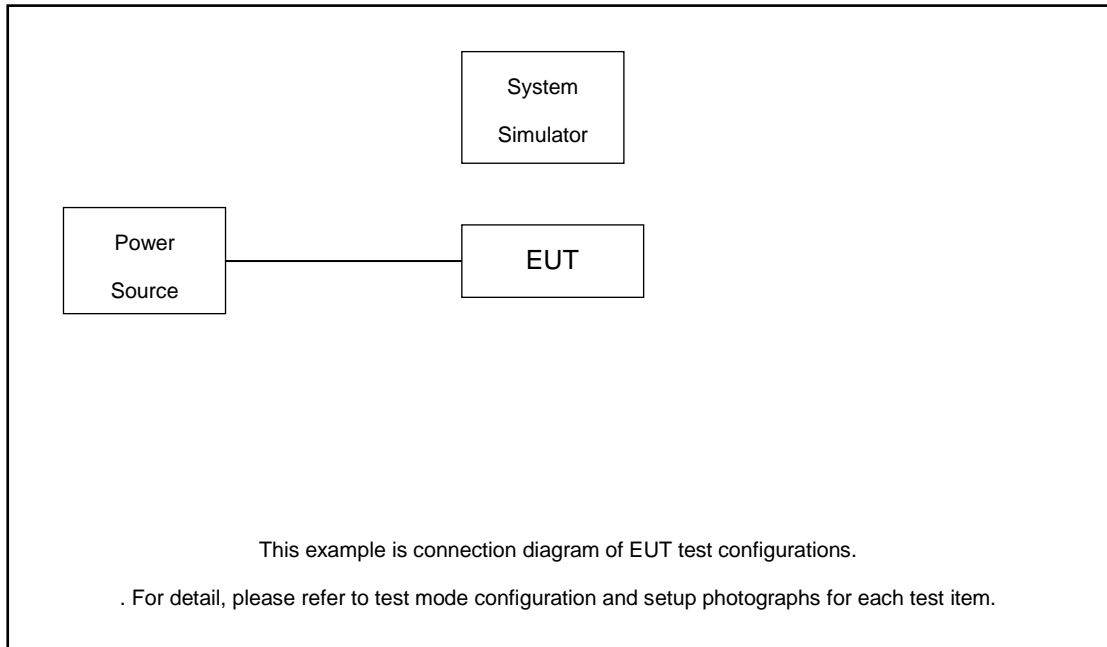



2.3 Support Unit used in test configuration and system

Item	Equipment	Trade Name	Model No.	FCC ID	Data Cable	Power Cord
1.	DC Power Supply	GW	GPS-3030D	N/A	N/A	Unshielded, 1.8 m
2.	LTE Base Station	Anritsu	MT8821C	N/A	N/A	Unshielded, 1.8 m
3.	NR Base Station	Anritsu	MT8000A	N/A	N/A	Unshielded, 1.8 m
4.	Fixture	INTEL	NGFF Card Carrier	N/A	N/A	N/A

2.4 Measurement Results Explanation Example

For all conducted test items:

The offset level is set in the spectrum analyzer to compensate the RF cable loss and attenuator factor between EUT conducted output port and spectrum analyzer. With the offset compensation, the spectrum analyzer reading level is exactly the EUT RF output level.

The spectrum analyzer offset is derived from RF cable loss and attenuator factor.

$$\text{Offset} = \text{RF cable loss.}$$

Following shows an offset computation example with cable loss 5.5 dB.

Example :

$$\begin{aligned} \text{Offset(dB)} &= \text{RF cable loss(dB)}. \\ &= 5.5 \text{ (dB)} \end{aligned}$$



2.5 Frequency List of Low/Middle/High Channels

5G NR n2 Channel and Frequency List				
BW [MHz]	Channel/Frequency(MHz)	Lowest	Middle	Highest
20	Channel	372000	376000	380000
	Frequency	1860	1880	1900
15	Channel	371500	376000	380500
	Frequency	1857.5	1880	1902.5
10	Channel	371000	376000	381000
	Frequency	1855	1880	1905
5	Channel	370500	376000	381500
	Frequency	1852.5	1880	1907.5

5G NR n5 Channel and Frequency List				
BW [MHz]	Channel/Frequency(MHz)	Lowest	Middle	Highest
20	Channel	166800	167300	167800
	Frequency	834	836.5	839
15	Channel	166300	167300	168300
	Frequency	831.5	836.5	841.5
10	Channel	165800	167300	168800
	Frequency	829	836.5	844
5	Channel	165300	167300	169300
	Frequency	826.5	836.5	846.5

5G NR n38 Channel and Frequency List				
BW [MHz]	Channel/Frequency(MHz)	Lowest	Middle	Highest
20	Channel	516000	519000	522000
	Frequency	2580	2595	2610



5G NR n41 Channel and Frequency List				
BW [MHz]	Channel/Frequency(MHz)	Lowest	Middle	Highest
100	Channel	509202	518598	528000
	Frequency	2546.01	2592.99	2640
90	Channel	508200	518598	528996
	Frequency	2541	2592.99	2644.98
80	Channel	507204	518598	529998
	Frequency	2536.02	2592.99	2649.99
60	Channel	505200	518598	531996
	Frequency	2526	2592.99	2659.98
50	Channel	504204	518598	532998
	Frequency	2521.02	2592.99	2664.99
40	Channel	503202	518598	534000
	Frequency	2516.01	2592.99	2670
20	Channel	501204	518598	535998
	Frequency	2506.02	2592.99	2679.99

5G NR n66 Channel and Frequency List				
BW [MHz]	Channel/Frequency(MHz)	Lowest	Middle	Highest
20	Channel	344000	349000	354000
	Frequency	1720	1745	1770
15	Channel	343500	349000	354500
	Frequency	1717.5	1745	1772.5
10	Channel	343000	349000	355000
	Frequency	1715	1745	1775
5	Channel	342500	349000	355500
	Frequency	1712.5	1745	1777.5



5G NR n71 Channel and Frequency List				
BW [MHz]	Channel/Frequency(MHz)	Lowest	Middle	Highest
20	Channel	134600	136100	137600
	Frequency	673	680.5	688
15	Channel	134100	136100	138100
	Frequency	670.5	680.5	690.5
10	Channel	133600	136100	138600
	Frequency	668	680.5	693
5	Channel	133100	136100	139100
	Frequency	665.5	680.5	695.5

3 Conducted Test Items

3.1 Measuring Instruments

See list of measuring instruments of this test report.

3.2 Test Setup

3.2.1 Conducted Output Power



3.2.2 Peak-to-Average Ratio, Occupied Bandwidth ,Conducted Band-Edge and Conducted Spurious Emission



3.2.3 Frequency Stability

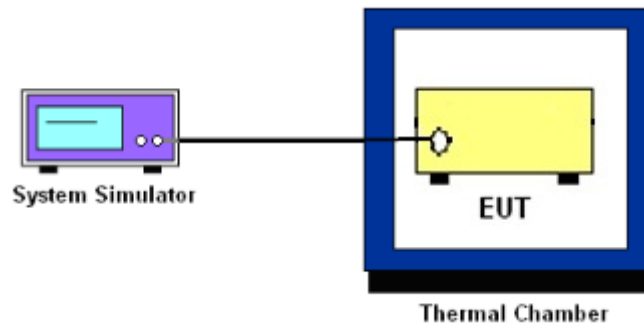

3.3 Test Result of Conducted Test

Please refer to Appendix A.



3.4 Conducted Output Power and ERP/EIRP

3.4.1 Description of the Conducted Output Power Measurement and ERP/EIRP Measurement

A system simulator was used to establish communication with the EUT. Its parameters were set to force the EUT transmitting at maximum output power. The measured power in the radio frequency on the transmitter output terminals shall be reported.

The ERP of mobile transmitters must not exceed 7 Watts for 5G NR n5.

The ERP of mobile transmitters must not exceed 3 Watts for 5G NR n71.

The EIRP of mobile transmitters must not exceed 2 Watts for 5G NR n2 and n38 and n41.

The EIRP of mobile transmitters must not exceed 1 Watts for 5G NR n66.

According to KDB 412172 D01 Power Approach,

$EIRP = P_T + G_T - L_C$, $ERP = EIRP - 2.15$, where

P_T = transmitter output power in dBm

G_T = gain of the transmitting antenna in dBi

L_C = signal attenuation in the connecting cable between the transmitter and antenna in dB

3.4.2 Test Procedures

1. The testing follows ANSI C63.26 Section 5.2
2. The transmitter output port was connected to the system simulator.
3. Set EUT at maximum power through the system simulator.
4. Select lowest, middle, and highest channels for each band and different modulation.
5. Measure and record the power level from the system simulator.



3.5 Peak-to-Average Ratio

3.5.1 Description of the PAR Measurement

Power Complementary Cumulative Distribution Function (CCDF) curves provide a means for characterizing the power peaks of a digitally modulated signal on a statistical basis. A CCDF curve depicts the probability of the peak signal amplitude exceeding the average power level. Most contemporary measurement instrumentation include the capability to produce CCDF curves for an input signal provided that the instrument's resolution bandwidth can be set wide enough to accommodate the entire input signal bandwidth. In measuring transmissions in this band using an average power technique, the peak-to-average ratio (PAR) of the transmission may not exceed 13 dB.

3.5.2 Test Procedures

1. The testing follows ANSI C63.26 Section 5.2.3.4 (CCDF).
2. The EUT was connected to spectrum and system simulator via a power divider.
3. Set the CCDF (Complementary Cumulative Distribution Function) option in spectrum analyzer.
4. The highest RF powers were measured and recorded the maximum PAPR level associated with a probability of 0.1 %.
5. Record the deviation as Peak to Average Ratio.



3.6 Occupied Bandwidth

3.6.1 Description of Occupied Bandwidth Measurement

The occupied bandwidth is the width of a frequency band such that, below the lower and above the upper frequency limits, the mean powers emitted are each equal to a specified percentage 0.5% of the total mean transmitted power.

The 26 dB emission bandwidth is defined as the frequency range between two points, one above and one below the carrier frequency, at which the spectral density of the emission is attenuated 26 dB below the maximum in-band spectral density of the modulated signal. Spectral density (power per unit bandwidth) is to be measured with a detector of resolution bandwidth equal to approximately 1.0% of the emission bandwidth.

3.6.2 Test Procedures

1. The testing follows ANSI C63.26 Section 5.4
2. The EUT was connected to spectrum analyzer and system simulator via a power divider.
3. The spectrum analyzer center frequency is set to the nominal EUT channel center frequency. The span range for the spectrum analyzer shall be between two and five times the anticipated OBW.
4. The nominal resolution bandwidth (RBW) shall be in the range of 1 to 5 % of the anticipated OBW, and the VBW shall be at least 3 times the RBW.
5. Set the detection mode to peak, and the trace mode to max hold.
6. Determine the reference value: Set the EUT to transmit a modulated signal. Allow the trace to stabilize. Set the spectrum analyzer marker to the highest level of the displayed trace.
(this is the reference value)
7. Determine the “-26 dB down amplitude” as equal to (Reference Value – X).
8. Place two markers, one at the lowest and the other at the highest frequency of the envelope of the spectral display such that each marker is at or slightly below the “-X dB down amplitude” determined in step 6. If a marker is below this “-X dB down amplitude” value it shall be placed as close as possible to this value. The OBW is the positive frequency difference between the two markers.
9. Use the 99 % power bandwidth function of the spectrum analyzer and report the measured bandwidth.



3.7 Conducted Band Edge

3.7.1 Description of Conducted Band Edge Measurement

22.917(a)

For operations in the 824 – 849 MHz band, the FCC limit is $43 + 10\log_{10}(P[\text{Watts}])$ dB below the transmitter power P(Watts) in a 100kHz bandwidth. However, in the 1MHz bands immediately outside and adjacent to the licensee's frequency block, a resolution bandwidth of at least one percent of the emission bandwidth of the fundamental emission of the transmitter may be employed.

24.238 (a)

For operations in the 1850-1910 and 1930-1990 MHz band, the FCC limit is $43 + 10\log_{10}(P[\text{Watts}])$ dB below the transmitter power P(Watts) in a 1MHz bandwidth. However, in the 1 MHz bands immediately outside and adjacent to the frequency block a resolution bandwidth of at least one percent of the emission bandwidth of the fundamental emission of the transmitter may be employed.

27.53 (g)

For operations in the 600MHz band and 698 -746 MHz band, the FCC limit is $43 + 10\log_{10}(P[\text{Watts}])$ dB below the transmitter power P(Watts) in a 100 kHz bandwidth. However, in the 100 kilohertz bands immediately outside and adjacent to a licensee's frequency block, a resolution bandwidth of at least 30 kHz may be employed.

27.53(m)(4)

For mobile digital stations, the attenuation factor shall be not less than $40 + 10 \log (P)$ dB on all frequencies between the channel edge and 5 megahertz from the channel edge, $43 + 10 \log (P)$ dB on all frequencies between 5 megahertz and X megahertz from the channel edge, and $55 + 10 \log (P)$ dB on all frequencies more than X megahertz from the channel edge, where X is the greater of 6 megahertz or the actual emission bandwidth as defined in paragraph (m)(6) of this section. In addition, the attenuation factor shall not be less that $43 + 10 \log (P)$ dB on all frequencies between 2490.5 MHz and 2496 MHz and $55 + 10 \log (P)$ dB at or below 2490.5 MHz. Mobile Satellite Service licensees operating on frequencies below 2495 MHz may also submit a documented interference complaint against BRS licensees operating on channel BRS Channel 1 on the same terms and conditions as adjacent channel BRS or EBS licensees.



3.7.2 Test Procedures

1. The testing follows ANSI C63.26 section 5.7
2. The EUT was connected to spectrum analyzer and system simulator via a power divider.
3. The band edges of low and high channels for the highest RF powers were measured.
4. Set RBW \geq 1% EBW in the 1MHz band immediately outside and adjacent to the band edge.
5. Beyond the 1 MHz band from the band edge, RBW=1MHz was used.
6. Set spectrum analyzer with RMS detector.
7. The RF fundamental frequency should be excluded against the limit line in the operating frequency band.
8. Checked that all the results comply with the emission limit line.

Example:

The limit line is derived from $43 + 10\log(P)$ dB below the transmitter power P(Watts)
= P(W)- [43 + 10log(P)] (dB)
= [30 + 10log(P)] (dBm) - [43 + 10log(P)] (dB) = -13dBm.

9. For 5G NR n38, n41, the other 40 dB, and 55 dB have additionally applied same calculation above.



3.8 Conducted Spurious Emission

3.8.1 Description of Conducted Spurious Emission Measurement

The power of any emission outside of the authorized operating frequency ranges must be lower than the transmitter power (P) by a factor of at least $43 + 10 \log (P)$ dB.

For 5G NR n38, n41:

The power of any emission outside of the authorized operating frequency ranges must be lower than the transmitter power (P) by a factor of at least $55 + 10 \log (P)$ dB.

It is measured by means of a calibrated spectrum analyzer and scanned from 30 MHz up to a frequency including its 10th harmonic.

3.8.2 Test Procedures

1. The testing follows ANSI C63.26 section 5.7
2. The EUT was connected to spectrum analyzer and system simulator via a power divider.
3. The RF output of EUT was connected to the spectrum analyzer by RF cable and attenuator. The path loss was compensated to the results for each measurement.
4. The middle channel for the highest RF power within the transmitting frequency was measured.
5. The conducted spurious emission for the whole frequency range was taken.
6. Make the measurement with the spectrum analyzer's RBW = 1MHz, VBW = 3MHz.
7. Set spectrum analyzer with RMS detector.
8. Taking the record of maximum spurious emission.
9. The RF fundamental frequency should be excluded against the limit line in the operating frequency band.
10. The limit line is derived from $43 + 10\log(P)$ dB below the transmitter power P(Watts)
 $= P(W) - [43 + 10\log(P)]$ (dB)
 $= [30 + 10\log(P)]$ (dBm) - $[43 + 10\log(P)]$ (dB)
 $= -13$ dBm.
11. For 5G NR n38, n41
The limit line is derived from $55 + 10\log(P)$ dB below the transmitter power P(Watts)
 $= P(W) - [55 + 10\log(P)]$ (dB)
 $= [30 + 10\log(P)]$ (dBm) - $[55 + 10\log(P)]$ (dB)
 $= -25$ dBm.



3.9 Frequency Stability

3.9.1 Description of Frequency Stability Measurement

The frequency stability shall be measured by variation of ambient temperature and variation of primary supply voltage to ensure that the fundamental emission stays within the authorized frequency block. The frequency stability of the transmitter shall be maintained within $\pm 0.00025\%$ ($\pm 2.5\text{ppm}$) of the center frequency.

3.9.2 Test Procedures for Temperature Variation

1. The testing follows ANSI C63.26 section 5.6.4
2. The EUT was set up in the thermal chamber and connected with the system simulator.
3. With power OFF, the temperature was decreased to -30°C and the EUT was stabilized before testing. Power was applied and the maximum change in frequency was recorded within one minute.
4. With power OFF, the temperature was raised in 10°C step up to 50°C . The EUT was stabilized at each step for at least half an hour. Power was applied and the maximum frequency change was recorded within one minute.

3.9.3 Test Procedures for Voltage Variation

1. The testing follows ANSI C63.26 section 5.6.5
2. The EUT was placed in a temperature chamber at $20\pm 5^{\circ}\text{C}$ and connected with the system simulator.
3. The power supply voltage to the EUT was varied from 85% to 115% of the nominal value for other than hand carried battery equipment.
4. For hand carried, battery powered equipment, reduce the primary ac or dc supply voltage to the battery operating end point, which shall be specified by the manufacturer.
5. The variation in frequency was measured for the worst case.

4 Radiated Test Items

4.1 Measuring Instruments

See list of measuring instruments of this test report.

4.2 Test Setup

4.2.1 For radiated test from 30MHz to 1GHz

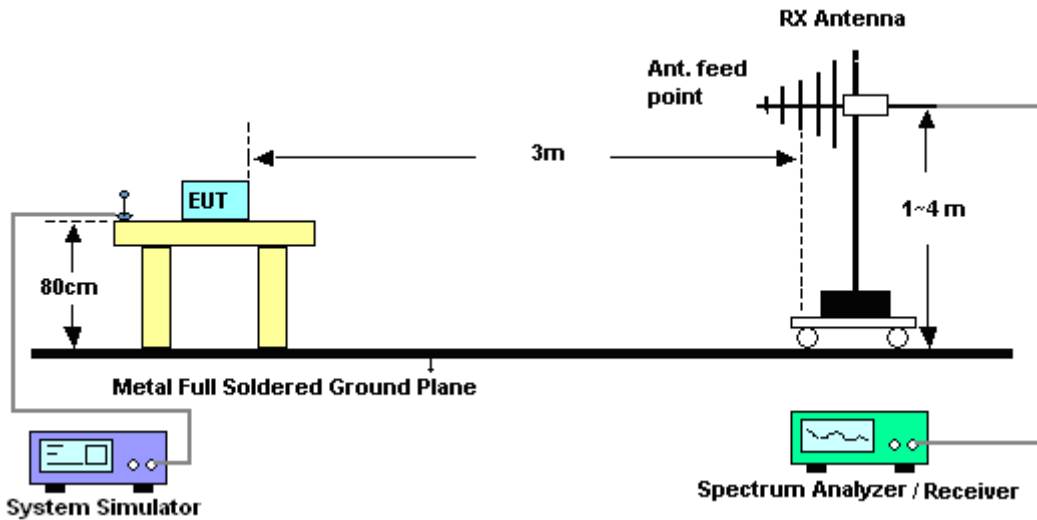

4.2.2 For radiated test above 1GHz

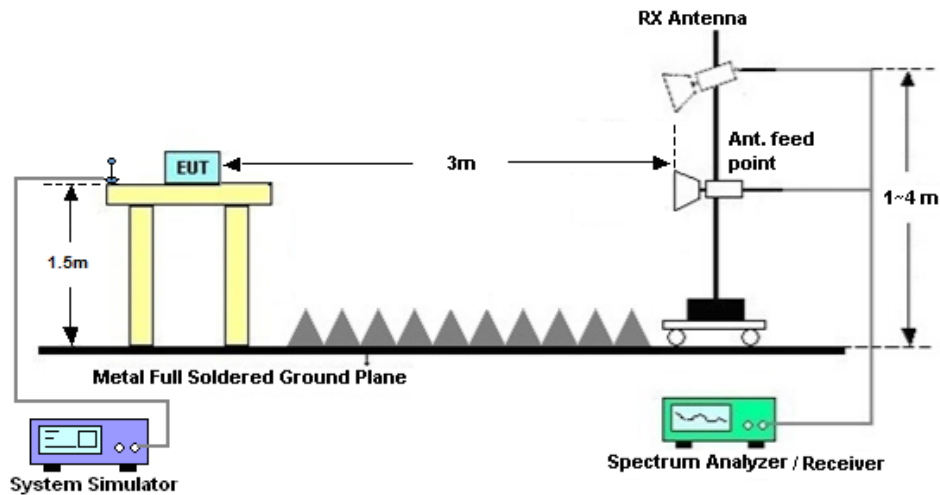

4.3 Test Result of Radiated Test

Please refer to Appendix B.



4.4 Radiated Spurious Emission

4.4.1 Description of Radiated Spurious Emission

The radiated spurious emission was measured by substitution method according to ANSI C63.26. The power of any emission outside of the authorized operating frequency ranges must be attenuated below the transmitter power (P) by a factor of at least $43 + 10 \log (P)$ dB.

For 5G NR n38, n41

The power of any emission outside of the authorized operating frequency ranges must be attenuated below the transmitter power (P) by a factor of at least $55 + 10 \log (P)$ dB.

The spectrum is scanned from 30 MHz up to a frequency including its 10th harmonic.

4.4.2 Test Procedures

1. The testing follows ANSI C63.26 Section 5.5
2. The EUT was placed on a turntable with 0.8 meter height for frequency below 1GHz and 1.5 meter height for frequency above 1GHz respectively above ground.
3. The EUT was set 3 meters from the receiving antenna mounted on the antenna tower.
4. The table was rotated 360 degrees to determine the position of the highest spurious emission.
5. The height of the receiving antenna is varied between 1m to 4m to search the maximum spurious emission for both horizontal and vertical polarizations.
6. During the measurement, the system simulator parameters were set to force the EUT transmitting at maximum output power.
7. Make the measurement with the spectrum analyzer's RBW = 1MHz, VBW = 3MHz, taking the record of maximum spurious emission.
8. A horn antenna was substituted in place of the EUT and was driven by a signal generator.
9. Tune the output power of signal generator to the same emission level with EUT maximum spurious emission.
10. $EIRP (dBm) = S.G. Power - Tx Cable Loss + Tx Antenna Gain$
11. $ERP (dBm) = EIRP - 2.15$
12. The RF fundamental frequency should be excluded against the limit line in the operating frequency band.

The limit line is derived from $43 + 10\log(P)$ dB below the transmitter power P(Watts)
 $= P(W) - [43 + 10\log(P)] (dB)$
 $= [30 + 10\log(P)] (dBm) - [43 + 10\log(P)] (dB)$
 $= -13dBm.$

13. For 5G NR n38, n41:

The limit line is derived from $55 + 10\log(P)$ dB below the transmitter power P(Watts)The limit line is derived from $55 + 10\log(P)$ dB below the transmitter power P(Watts)



5 List of Measuring Equipment

Instrument	Manufacturer	Model No.	Serial No.	Characteristics	Calibration Date	Test Date	Due Date	Remark
Spectrum Analyzer	R&S	FSV40	101040	10Hz~40GHz	Nov. 02, 2019	Jun. 29, 2020~ Jul. 31, 2020	Nov. 01, 2020	Conducted (TH01-KS)
Thermal Chamber	Ten Billion	TTC-B3S	TBN-960502	-40~+150°C	Oct. 28, 2019	Jun. 29, 2020~ Jul. 31, 2020	Oct. 27, 2020	Conducted (TH01-KS)
EXA Spectrum Analyzer	Keysight	N9010A	MY55150244	10Hz-44G,MAX 30dB	Apr. 15, 2020	Jun. 28, 2020~ Aug. 11, 2020	Apr. 14, 2021	Radiation (03CH04-KS)
Bilog Antenna	TeseQ	CBL6111D	49922	30MHz-1GHz	Jan. 02, 2020	Jun. 28, 2020~ Aug. 11, 2020	Jan. 03, 2021	Radiation (03CH04-KS)
Horn Antenna	Schwarzbeck	BBHA9120D	1356	1GHz~18GHz	Apr. 20, 2020	Jun. 28, 2020~ Aug. 11, 2020	Apr. 19, 2021	Radiation (03CH04-KS)
SHF-EHF Horn	Com-power	AH-840	101115	18GHz~40GHz	Nov. 10, 2019	Jun. 28, 2020~ Aug. 11, 2020	Nov. 09, 2020	Radiation (03CH04-KS)
Amplifier	SONOMA	310N	187289	9KHz-1GHz	Jan. 02, 2020	Jun. 28, 2020~ Aug. 11, 2020	Jan. 03, 2021	Radiation (03CH04-KS)
Amplifier	MITEQ	EM18G40G GA	060728	18~40GHz	Jan. 08, 2020	Jun. 28, 2020~ Aug. 11, 2020	Jan. 07, 2021	Radiation (03CH04-KS)
high gain Amplifier	MITEQ	AMF-7D-00 101800-30-1 QP	2025788	1Ghz-18Ghz	Jan. 02, 2020	Jun. 28, 2020~ Aug. 11, 2020	Jan. 03, 2021	Radiation (03CH04-KS)
Amplifier	Keysight	83017A	MY57280106	500MHz~26.5GHz	Oct. 15, 2019	Jun. 28, 2020~ Aug. 11, 2020	Oct. 14, 2020	Radiation (03CH04-KS)
AC Power Source	Chroma	61601	F104090004	N/A	NCR	Jun. 28, 2020~ Aug. 11, 2020	NCR	Radiation (03CH04-KS)
Turn Table	ChamPro	EM 1000-T	060762-T	0~360 degree	NCR	Jun. 28, 2020~ Aug. 11, 2020	NCR	Radiation (03CH04-KS)
Antenna Mast	ChamPro	EM 1000-A	060762-A	1 m~4 m	NCR	Jun. 28, 2020~ Aug. 11, 2020	NCR	Radiation (03CH04-KS)

NCR: No Calibration Required



6 Uncertainty of Evaluation

The measurement uncertainties shown below were calculated in accordance with the requirements of ANSI 63.26-2015. All the measurement uncertainty value were shown with a coverage K=2 to indicate 95% level of confidence. The measurement data show herein meets or exceeds the CISPR measurement uncertainty values specified in CISPR 16-4-2 and can be compared directly to specified limit to determine compliance.

Uncertainty of Radiated Emission Measurement (30 MHz ~ 1000 MHz)

Measuring Uncertainty for a Level of Confidence of 95% (U = 2Uc(y))	3.3dB
---	-------

Uncertainty of Radiated Emission Measurement (1 GHz ~ 18 GHz)

Measuring Uncertainty for a Level of Confidence of 95% (U = 2Uc(y))	2.8dB
---	-------

Uncertainty of Radiated Emission Measurement (18 GHz ~ 40 GHz)

Measuring Uncertainty for a Level of Confidence of 95% (U = 2Uc(y))	2.8dB
---	-------



Appendix A. Test Results of Conducted Test

Conducted Output Power(Average power and EIRP)



5G NR n2

Peak-to-Average Ratio

Mode	FR1 n2 / 20MHz / DFT-S OFDM				
Mod.	PI/2 BPSK	QPSK	16QAM	64QAM	Limit: 13dB
RB Size	Full RB	Full RB	Full RB	Full RB	Result
Lowest CH	3.74	4.26	5.45	5.86	PASS
Middle CH	3.62	4.26	5.48	5.91	
Highest CH	3.94	4.58	5.68	6.06	
Mode	FR1 n2 / 20MHz / DFT-S OFDM				
Mod.	256QAM				Limit: 13dB
RB Size	Full RB				Result
Lowest CH	6.43				PASS
Middle CH	6.43				
Highest CH	6.41				
Mode	FR1 n2 / 20MHz / DFT-S OFDM				
Mod.	PI/2 BPSK	QPSK	16QAM	64QAM	Limit: 13dB
RB Size	1 RB0	1 RB0	1 RB0	1 RB0	Result
Lowest CH	4.43	4.20	4.99	6.14	PASS
Middle CH	4.58	4.29	5.07	6.03	
Highest CH	4.23	3.88	4.64	5.77	
Mode	FR1 n2 / 20MHz / DFT-S OFDM				
Mod.	256QAM				Limit: 13dB
RB Size	1 RB0				Result
Lowest CH	7.10				PASS
Middle CH	6.43				
Highest CH	6.46				



FR1 n2 / 20MHz / DFT-S OFDM

PI/2 BPSK

QPSK

Lowest Channel / Full RB

Lowest Channel / Full RB

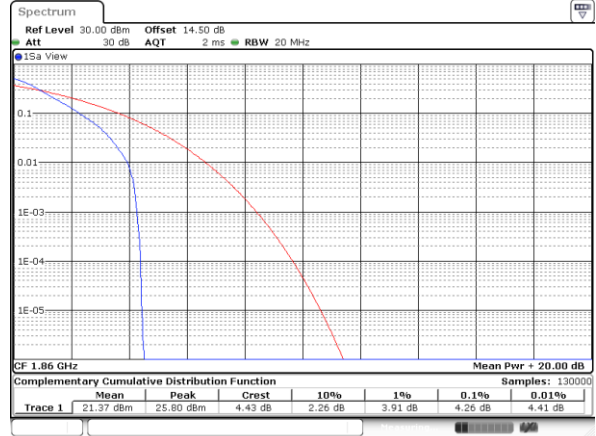
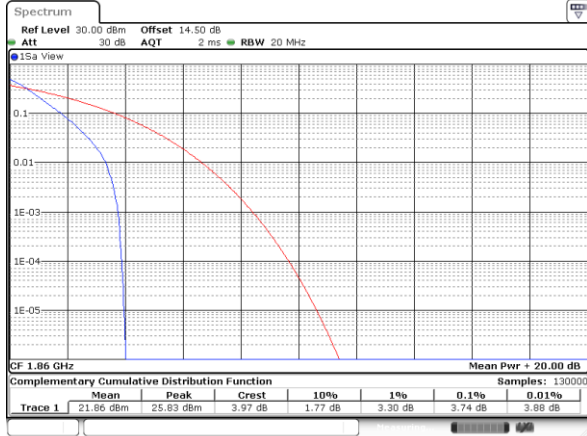

Date: 31 JUL 2020 05:38:22

Date: 31 JUL 2020 05:37:02

Middle Channel / Full RB

Middle Channel / Full RB

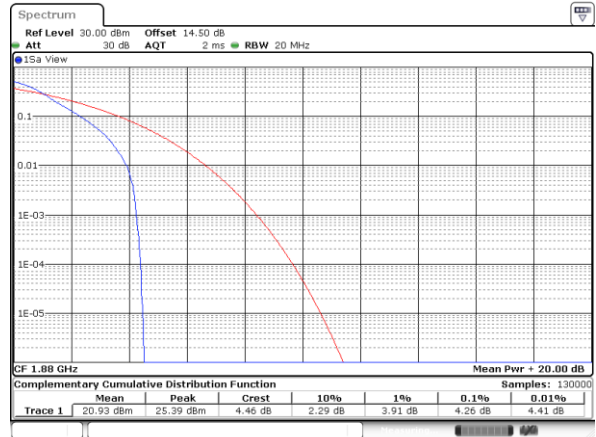
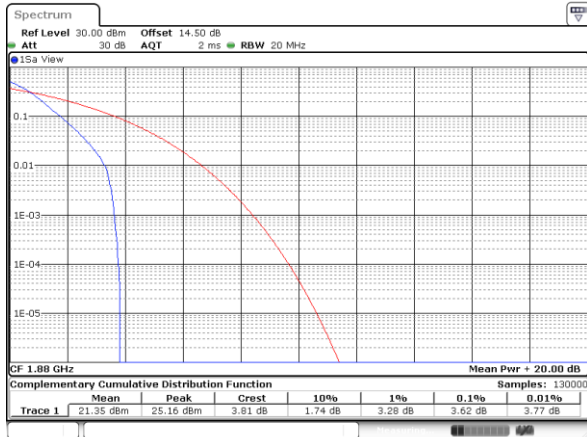

Date: 31 JUL 2020 05:32:55

Date: 31 JUL 2020 05:33:06

Highest Channel / Full RB

Highest Channel / Full RB

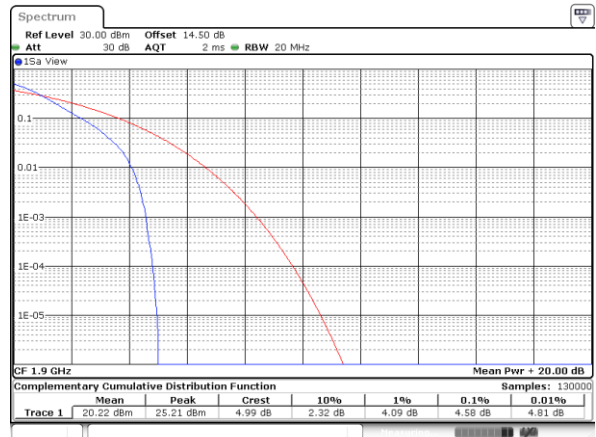
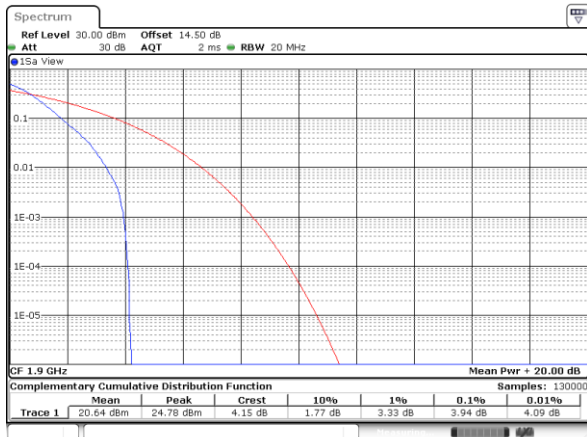

Date: 31 JUL 2020 05:32:17

Date: 31 JUL 2020 05:31:46



FR1 n2 / 20MHz / DFT-S OFDM

16QAM

64QAM

Lowest Channel / Full RB

Lowest Channel / Full RB

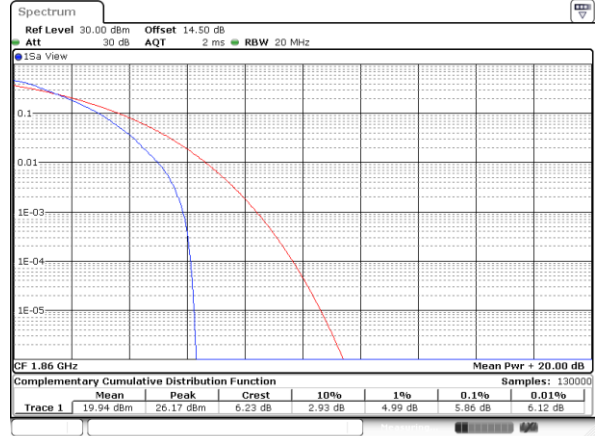
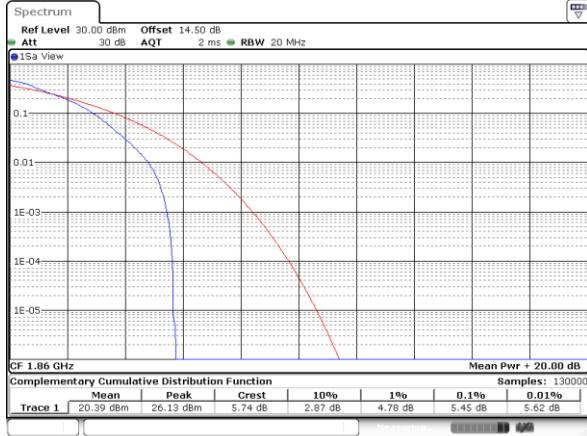

Date: 31 JUL 2020 05:36:52

Date: 31 JUL 2020 05:36:40

Middle Channel / Full RB

Middle Channel / Full RB

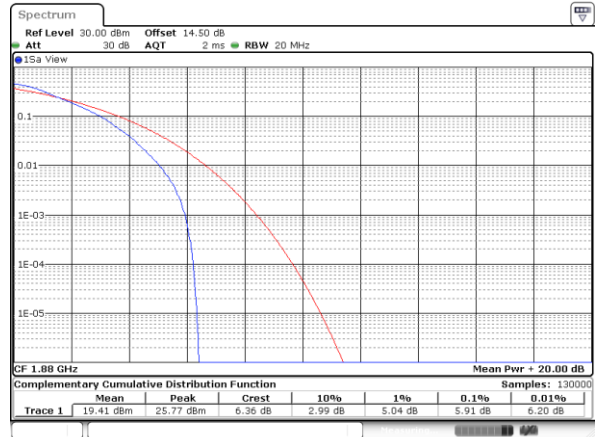
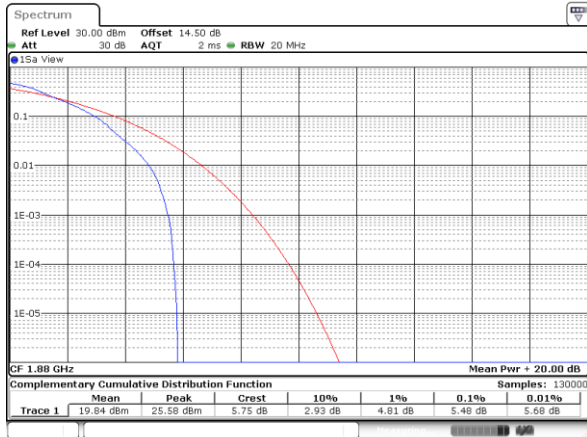

Date: 31 JUL 2020 05:33:19

Date: 31 JUL 2020 05:33:34

Highest Channel / Full RB

Highest Channel / Full RB

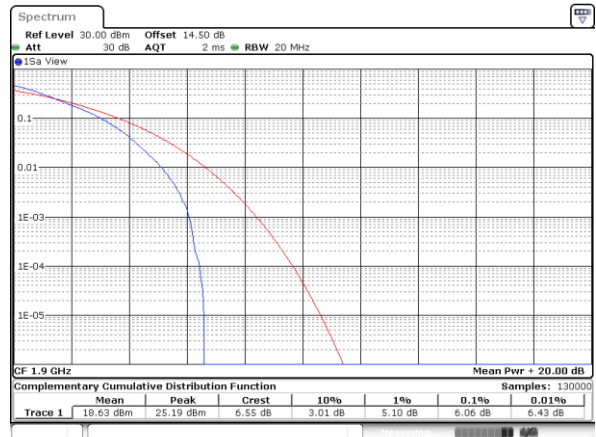
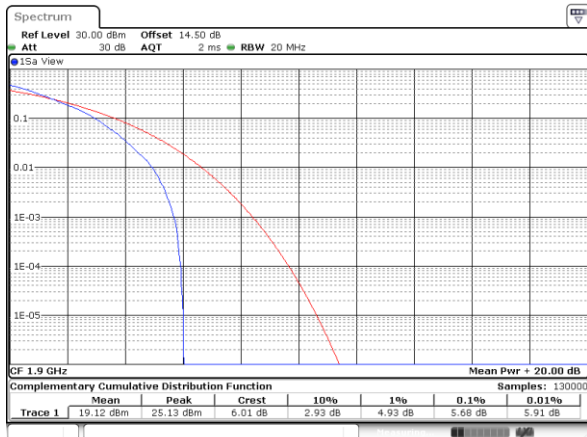

Date: 31 JUL 2020 05:31:36

Date: 31 JUL 2020 05:30:43

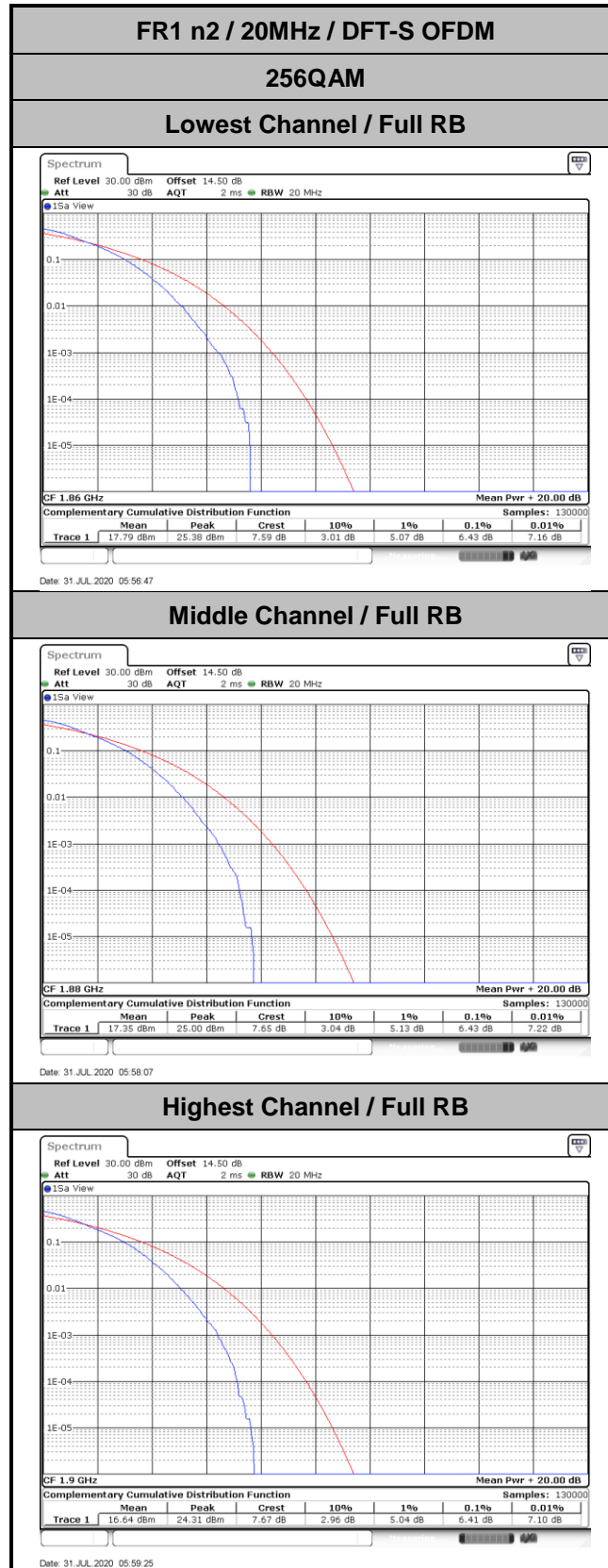



FR1 n2 / 20MHz / DFT-S OFDM

PI/2 BPSK

QPSK

Lowest Channel / 1RB0

Lowest Channel / 1RB0

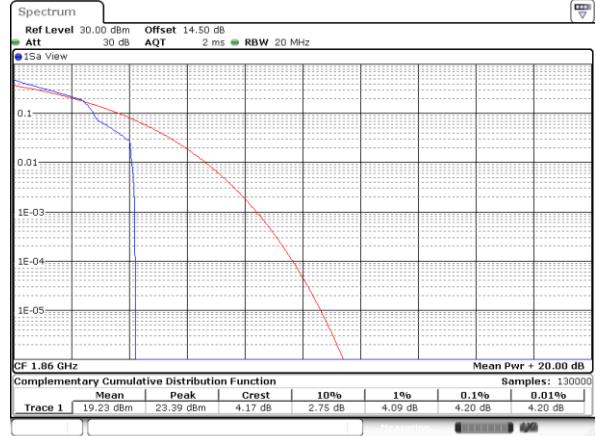
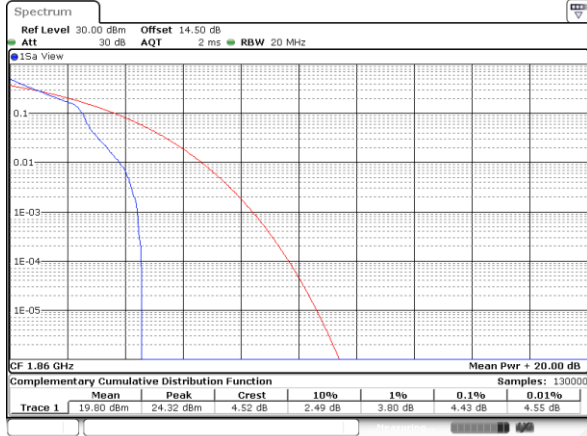

Date: 31 JUL 2020 05:35:16

Date: 31 JUL 2020 05:35:27

Middle Channel / 1RB0

Middle Channel / 1RB0

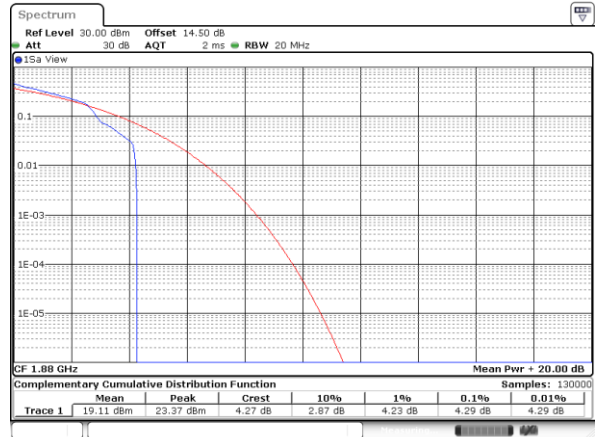
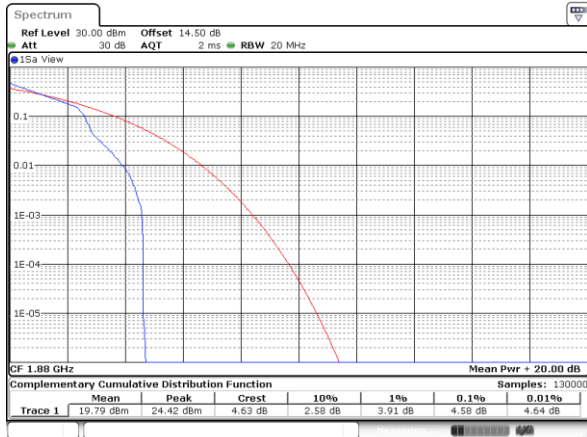

Date: 31 JUL 2020 05:34:21

Date: 31 JUL 2020 05:34:11

Highest Channel / 1RB0

Highest Channel / 1RB0

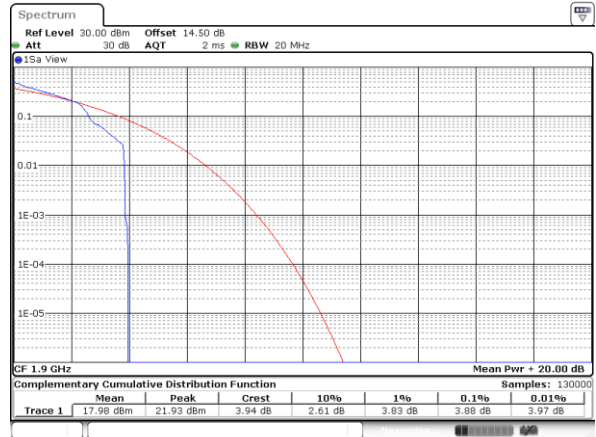
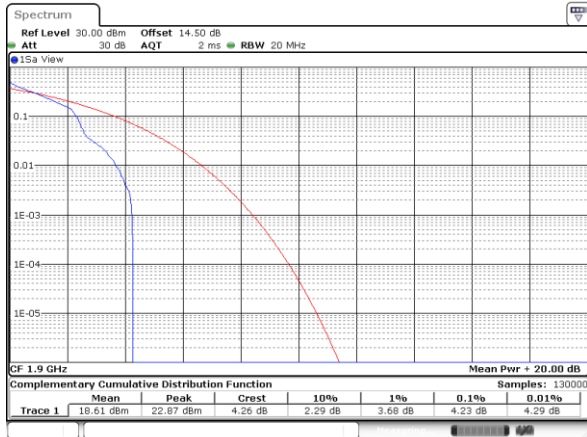

Date: 31 JUL 2020 05:32:06

Date: 31 JUL 2020 05:31:55



FR1 n2 / 20MHz / DFT-S OFDM

16QAM

64QAM

Lowest Channel / 1RB0

Lowest Channel / 1RB0

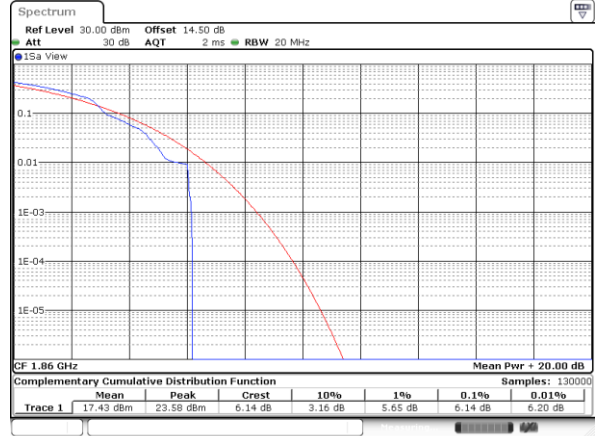

Date: 31 JUL 2020 05:35:41

Date: 31 JUL 2020 05:35:53

Middle Channel / 1RB0

Middle Channel / 1RB0

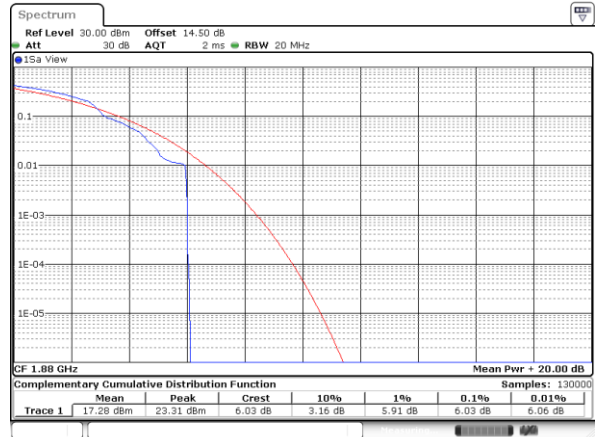
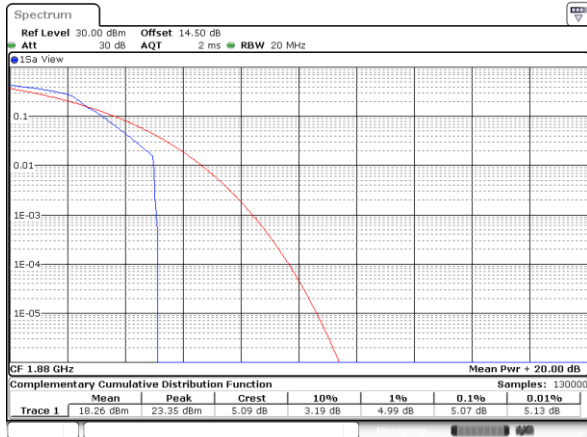

Date: 31 JUL 2020 05:34:00

Date: 31 JUL 2020 05:33:46

Highest Channel / 1RB0

Highest Channel / 1RB0

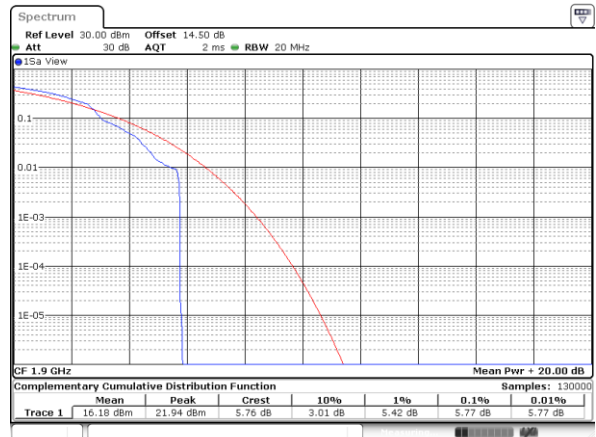
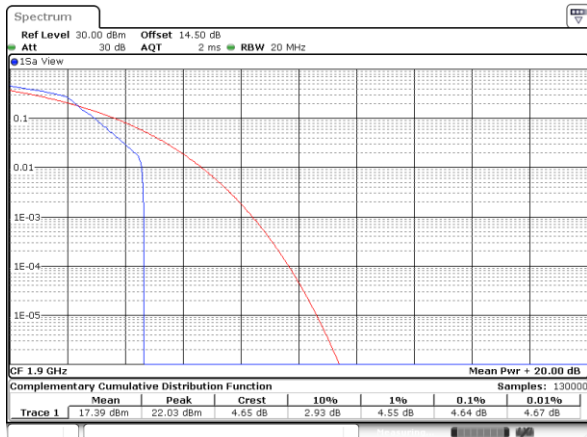

Date: 31 JUL 2020 05:31:21

Date: 31 JUL 2020 05:31:05

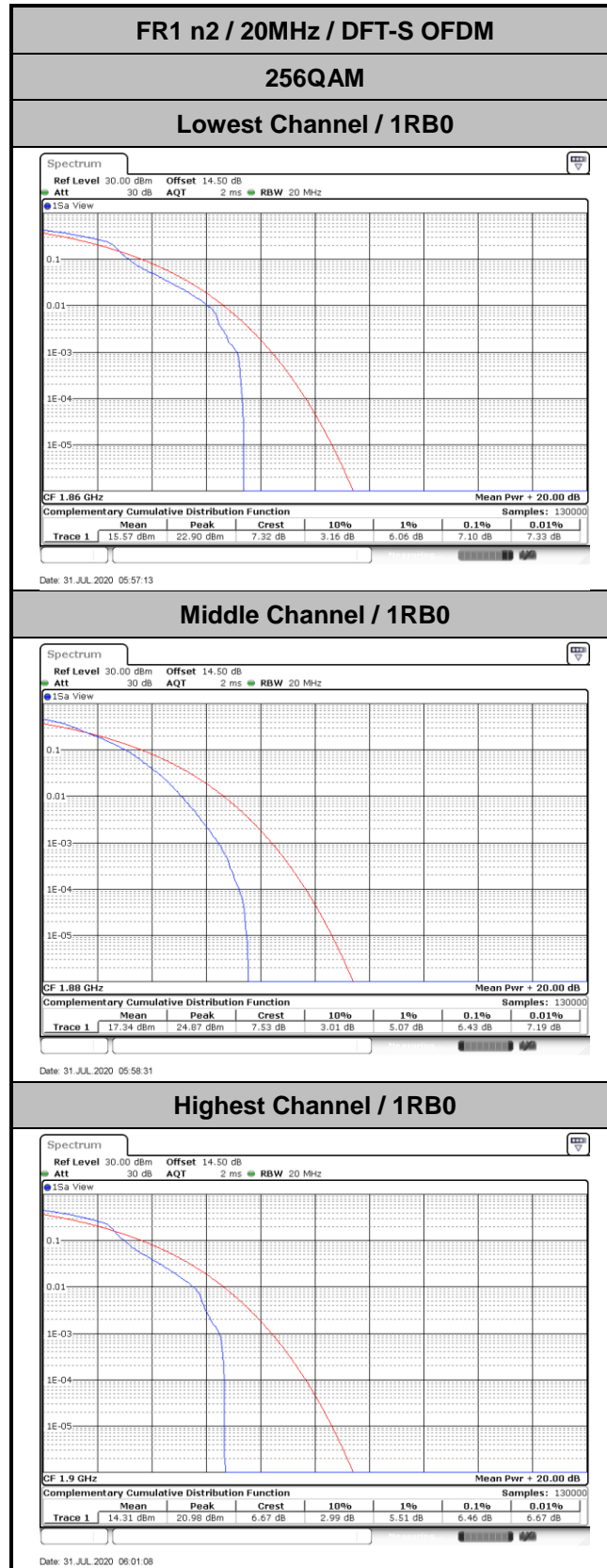



26dB Bandwidth

Mode	FR1 n2 : 26dB BW(MHz) / DFT-S OFDM							
BW	5MHz		10MHz		15MHz		20MHz	
Mod.	PI /2 BPSK	QPSK	PI /2 BPSK	QPSK	PI /2 BPSK	QPSK	PI /2 BPSK	QPSK
Lowest CH	5.15	5.09	9.97	9.81	14.27	14.30	20.18	20.26
Middle CH	5.19	5.17	9.65	9.65	14.36	14.54	20.18	20.18
Highest CH	5.15	4.94	9.85	9.81	14.45	14.51	20.06	20.18
Mode	FR1 n2 : 26dB BW(MHz) / DFT-S OFDM							
BW	5MHz		10MHz		15MHz		20MHz	
Mod.	16QAM	64QAM	16QAM	64QAM	16QAM	64QAM	16QAM	64QAM
Lowest CH	5.21	5.16	9.87	10.01	14.27	14.39	20.14	20.10
Middle CH	4.97	5.11	10.01	9.77	14.36	14.48	20.22	20.22
Highest CH	5.03	5.18	9.71	9.83	14.45	14.39	20.26	20.18
Mode	FR1 n2 : 26dB BW(MHz) / DFT-S OFDM							
BW	5MHz		10MHz		15MHz		20MHz	
Mod.	256QAM		256QAM		256QAM		256QAM	
Lowest CH	5.27		9.73		14.42		20.18	
Middle CH	5.07		9.77		14.48		20.26	
Highest CH	5.14		9.89		14.45		20.26	

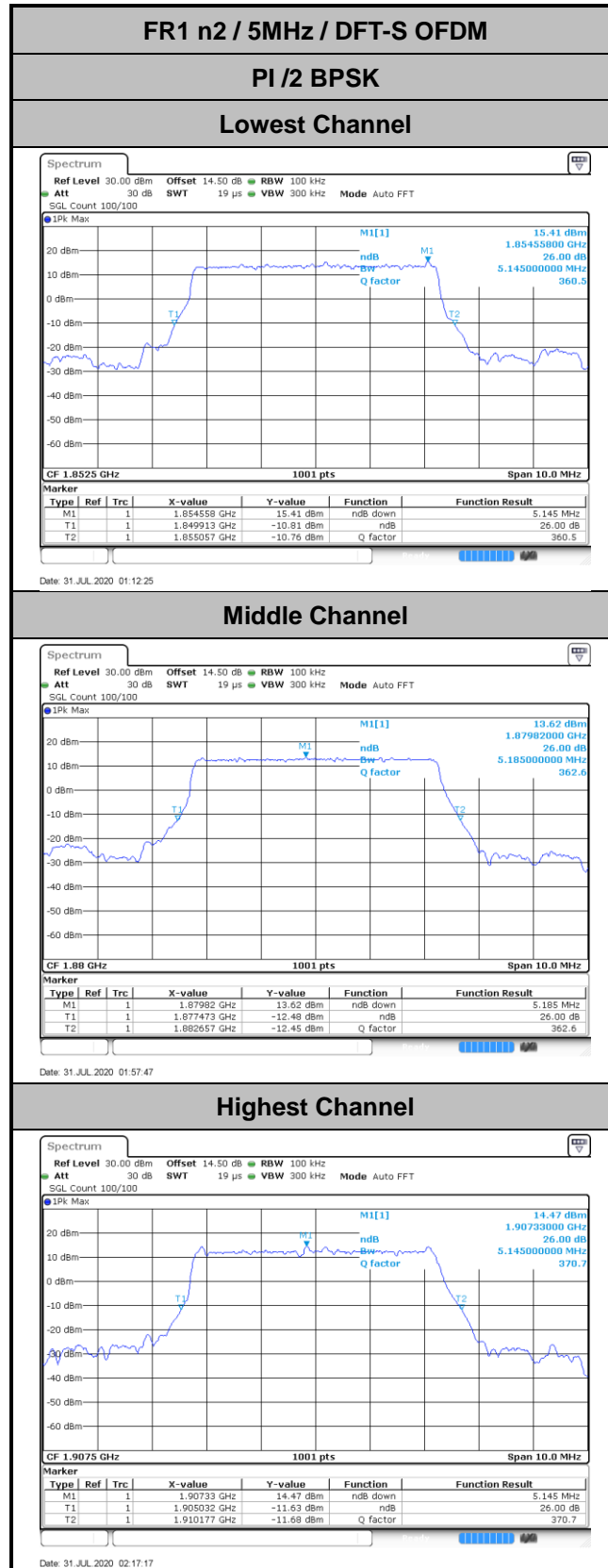



FR1 n2 / 5MHz / DFT-S OFDM

QPSK

16QAM

Lowest Channel

Lowest Channel

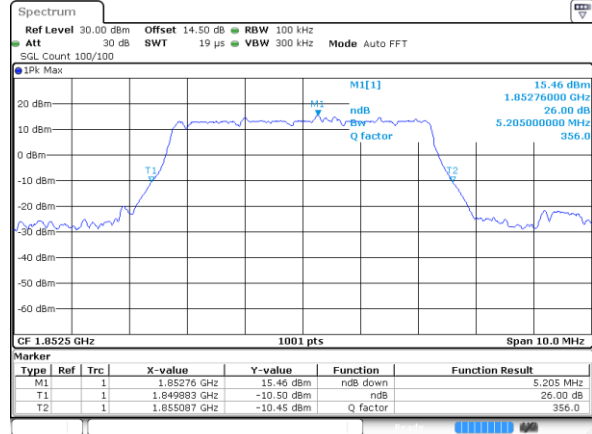
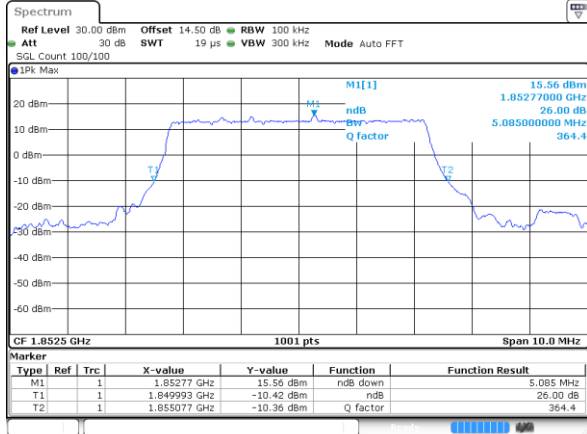

Date: 31 JUL 2020 01:14:20

Date: 31 JUL 2020 01:15:56

Middle Channel

Middle Channel

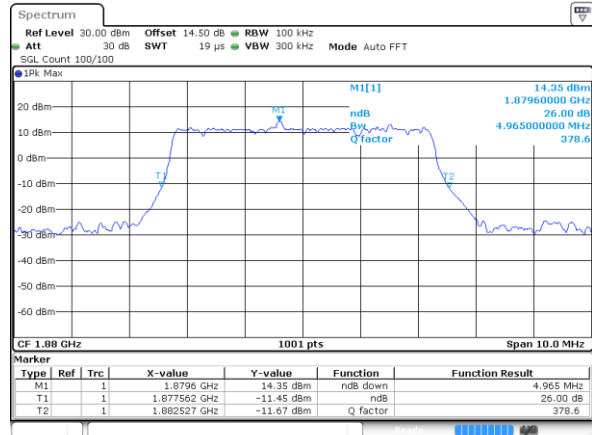
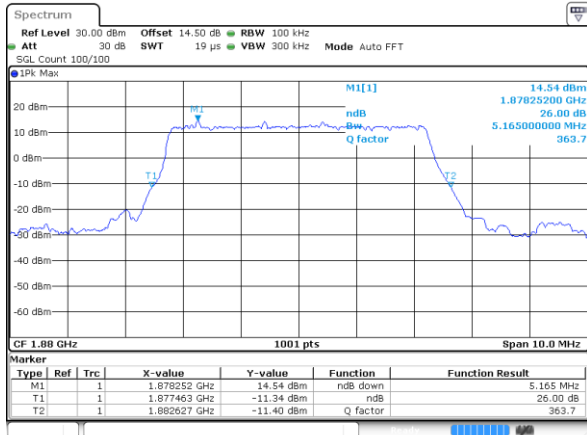

Date: 31 JUL 2020 01:58:08

Date: 31 JUL 2020 01:58:33

Highest Channel

Highest Channel

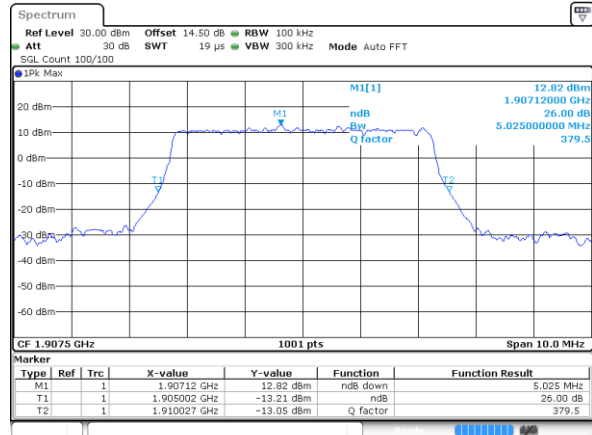
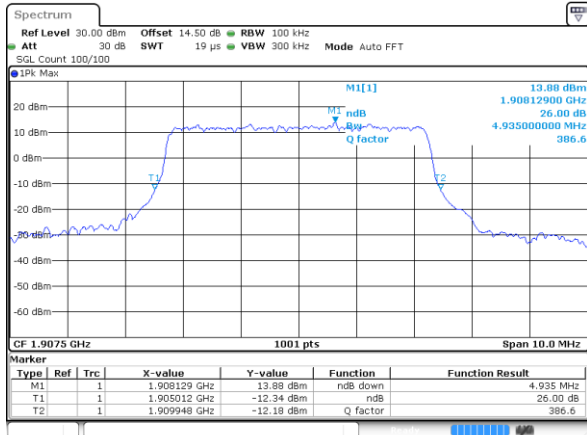

Date: 31 JUL 2020 02:19:10

Date: 31 JUL 2020 02:19:33



FR1 n2 / 5MHz / DFT-S OFDM

64QAM

256QAM

Lowest Channel

Lowest Channel

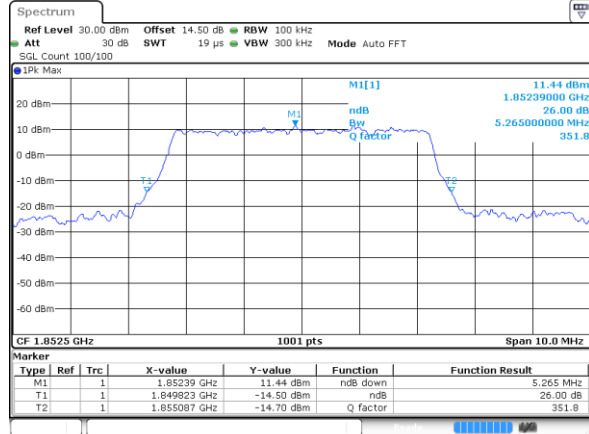
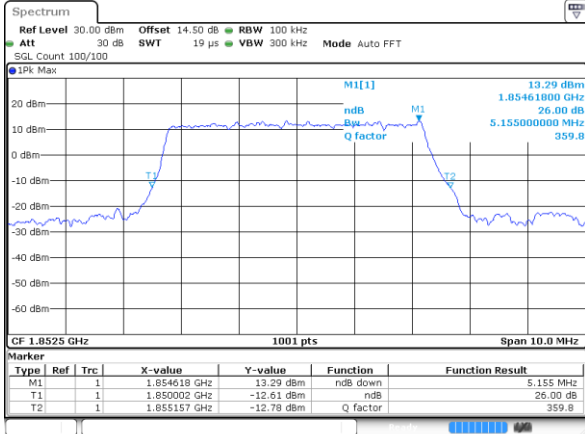

Date: 31 JUL 2020 01:17:44

Date: 31 JUL 2020 01:56:09

Middle Channel

Middle Channel

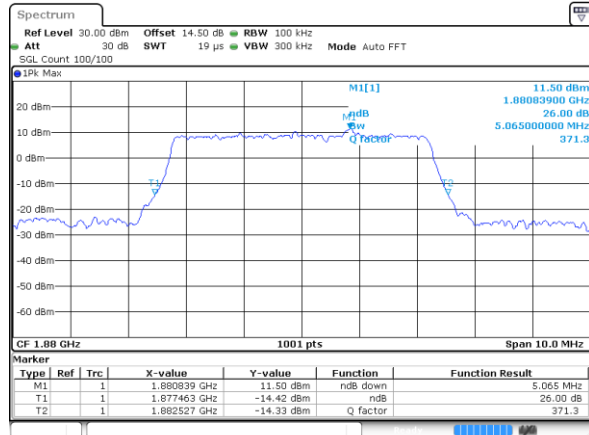
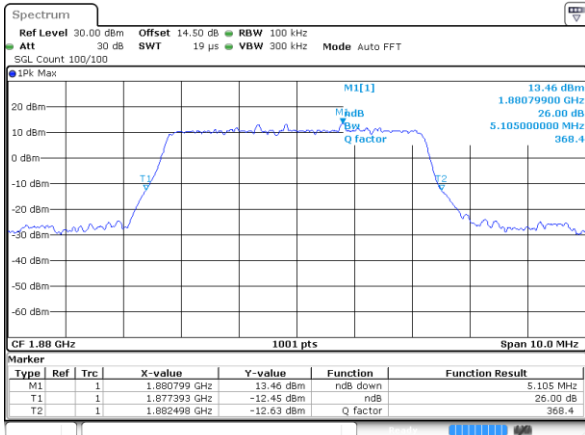

Date: 31 JUL 2020 01:58:52

Date: 31 JUL 2020 01:59:59

Highest Channel

Highest Channel

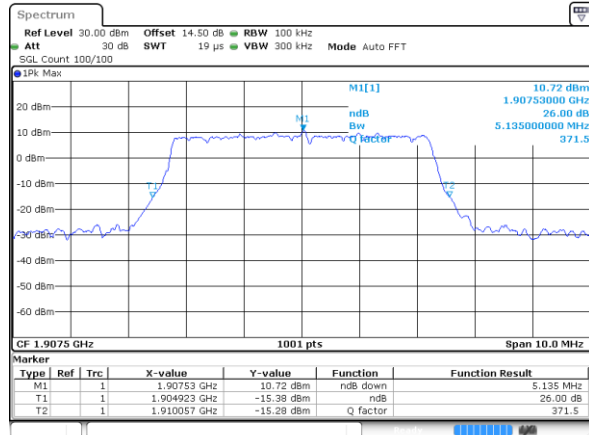
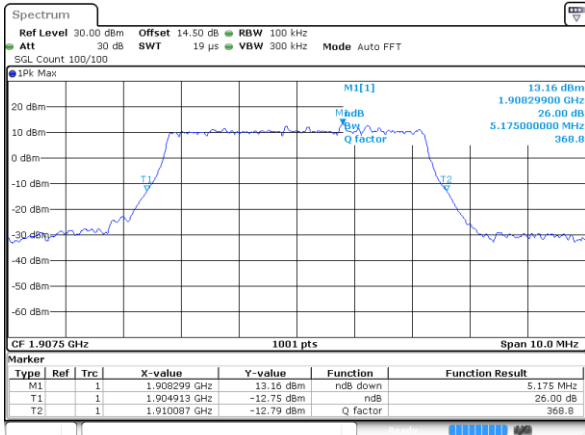

Date: 31 JUL 2020 02:21:23

Date: 31 JUL 2020 02:24:45

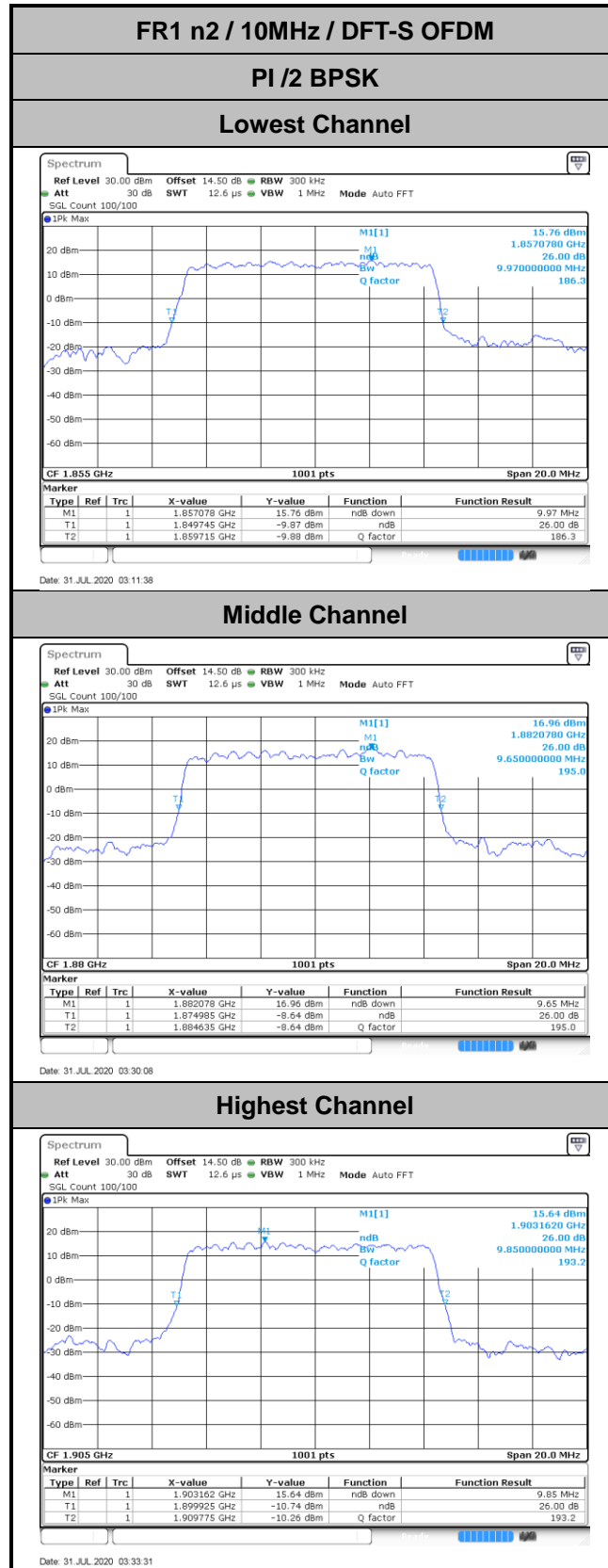



FR1 n2 / 10MHz / DFT-S OFDM

QPSK

16QAM

Lowest Channel

Lowest Channel

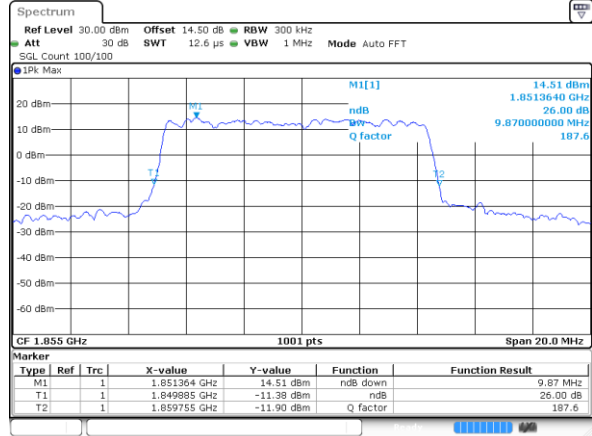
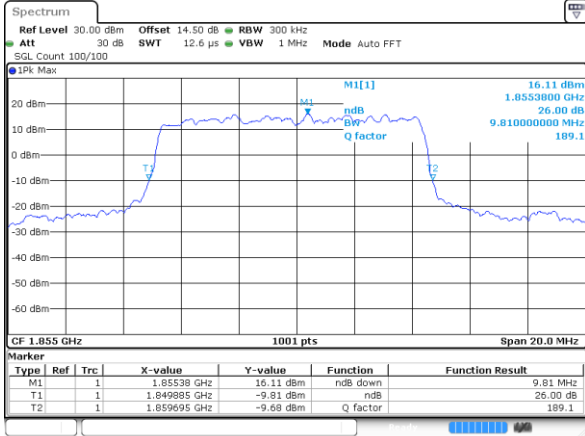

Date: 31 JUL 2020 03:14:16

Date: 31 JUL 2020 03:14:51

Middle Channel

Middle Channel

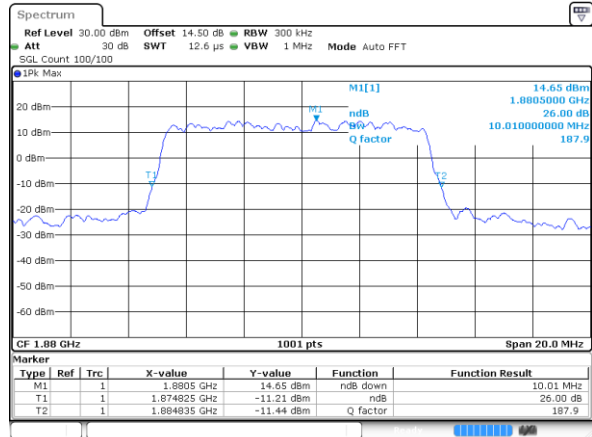
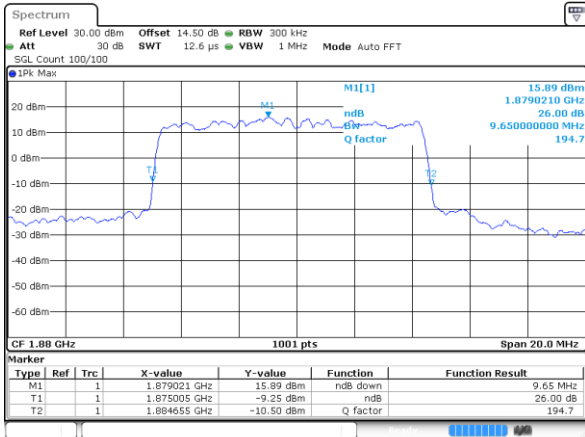

Date: 31 JUL 2020 03:30:25

Date: 31 JUL 2020 03:30:43

Highest Channel

Highest Channel

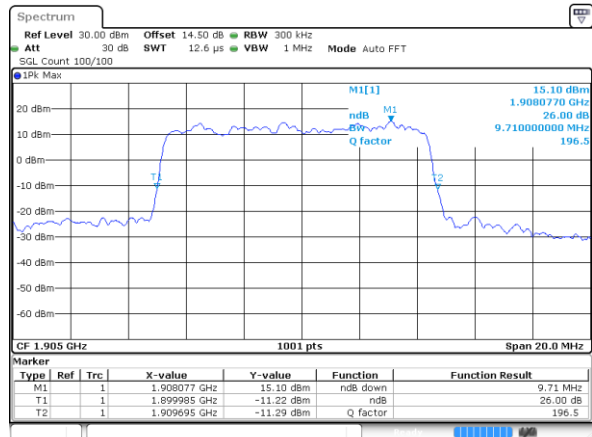
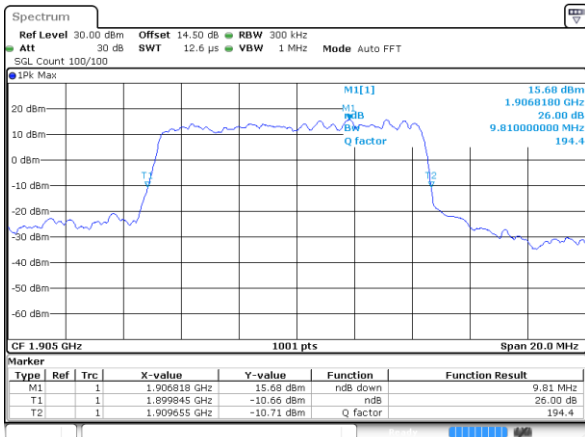

Date: 31 JUL 2020 03:35:35

Date: 31 JUL 2020 03:36:38



FR1 n2 / 10MHz / DFT-S OFDM

64QAM

256QAM

Lowest Channel

Lowest Channel

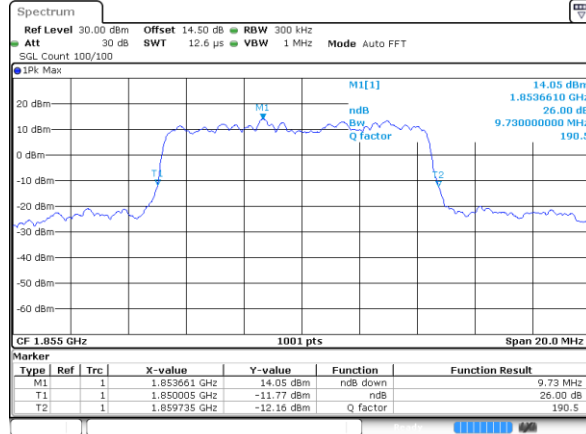
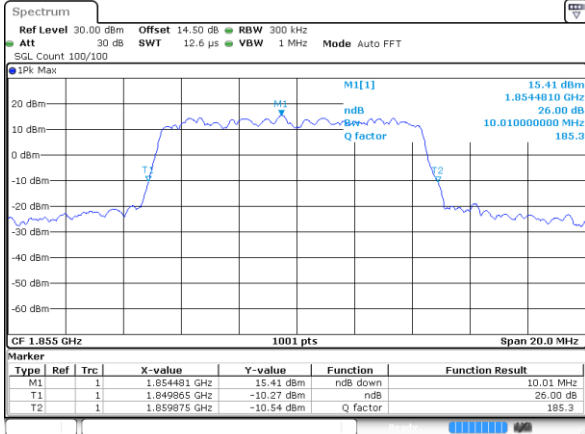

Date: 31 JUL 2020 03:16:19

Date: 31 JUL 2020 03:18:07

Middle Channel

Middle Channel

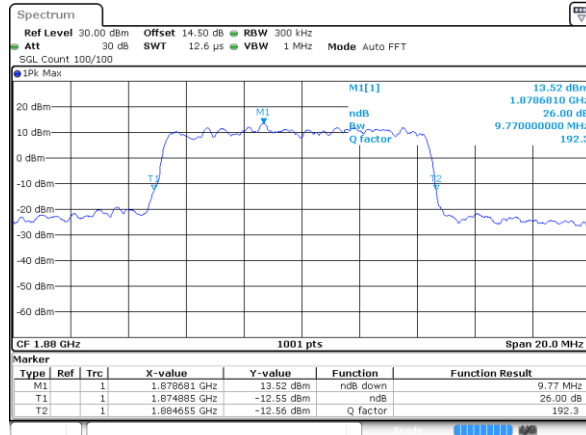
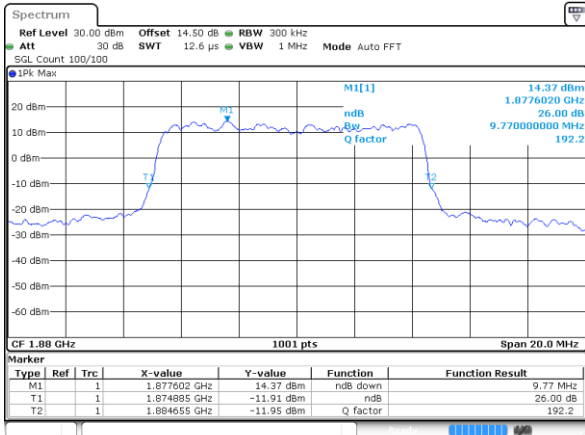

Date: 31 JUL 2020 03:30:59

Date: 31 JUL 2020 03:31:41

Highest Channel

Highest Channel

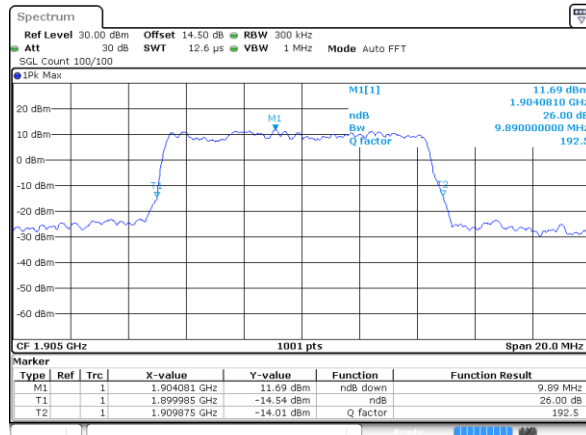
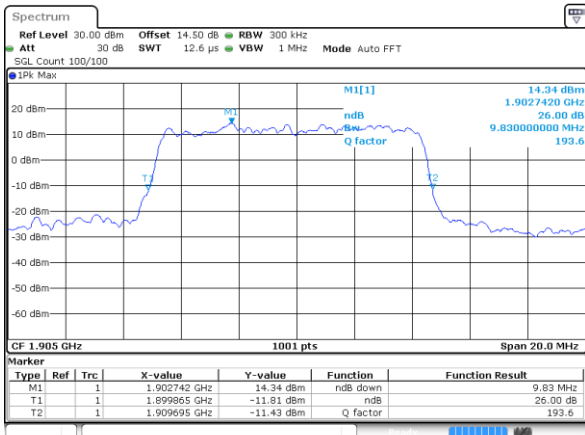

Date: 31 JUL 2020 03:50:46

Date: 31 JUL 2020 04:33:32

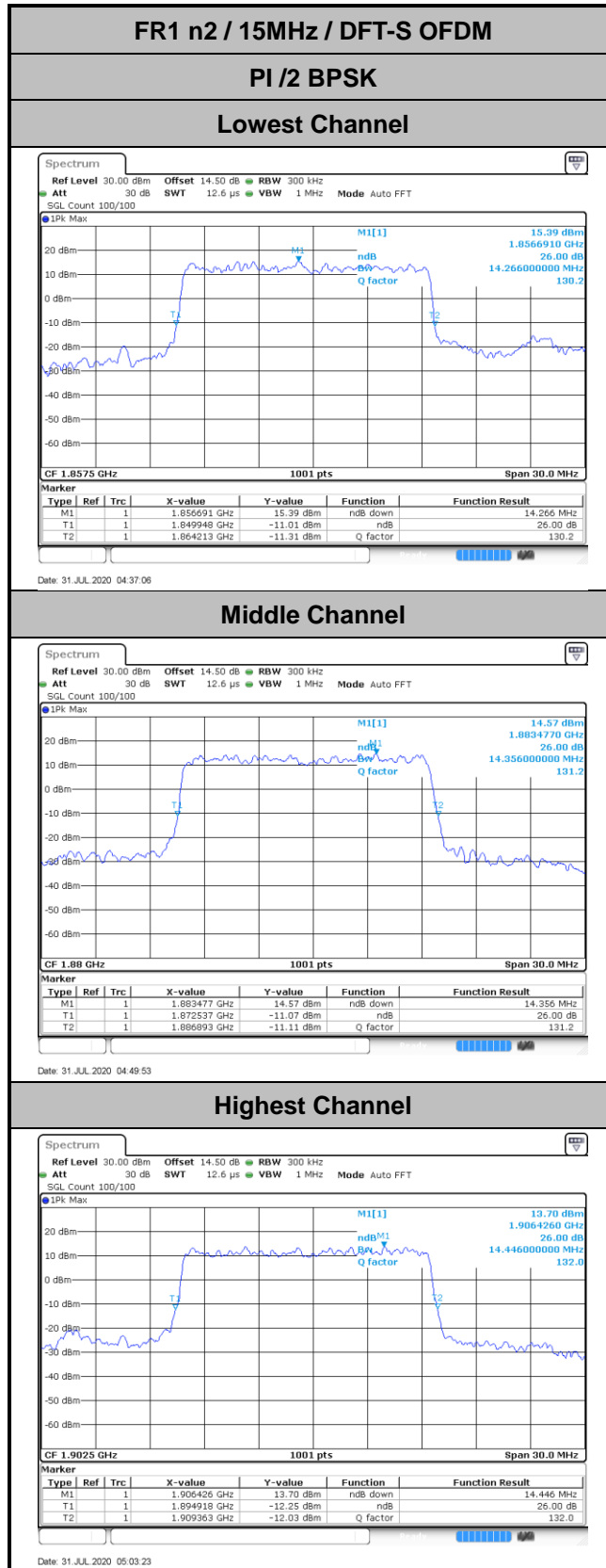



FR1 n2 / 15MHz / DFT-S OFDM

QPSK

16QAM

Lowest Channel

Lowest Channel

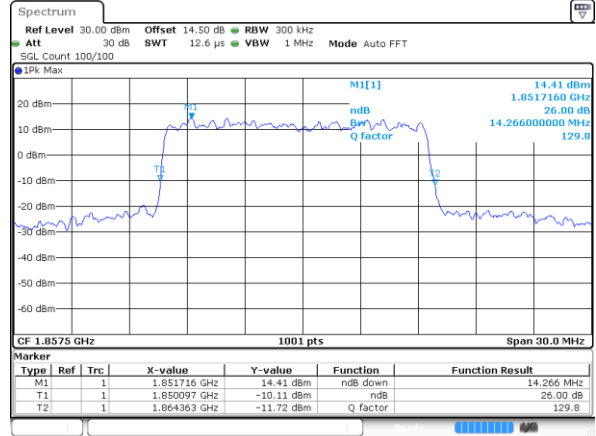
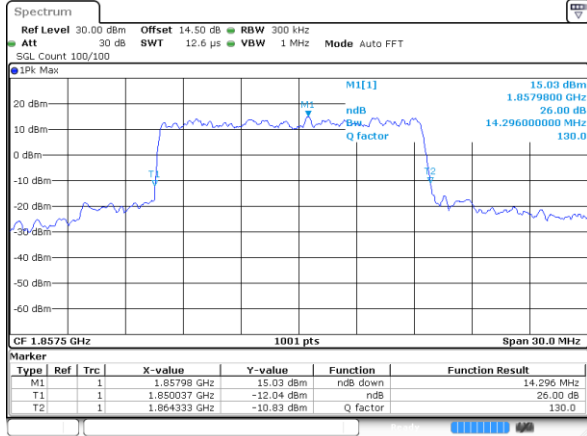

Date: 31 JUL 2020 04:38:33

Date: 31 JUL 2020 04:39:04

Middle Channel

Middle Channel

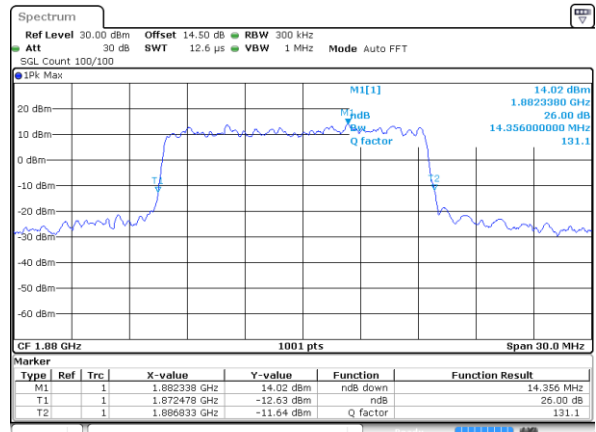
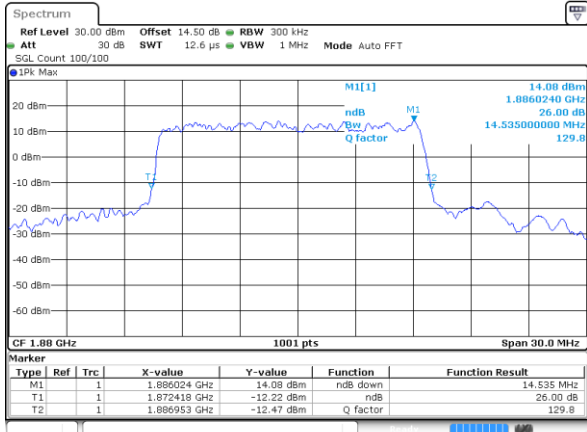

Date: 31 JUL 2020 04:50:11

Date: 31 JUL 2020 04:50:31

Highest Channel

Highest Channel

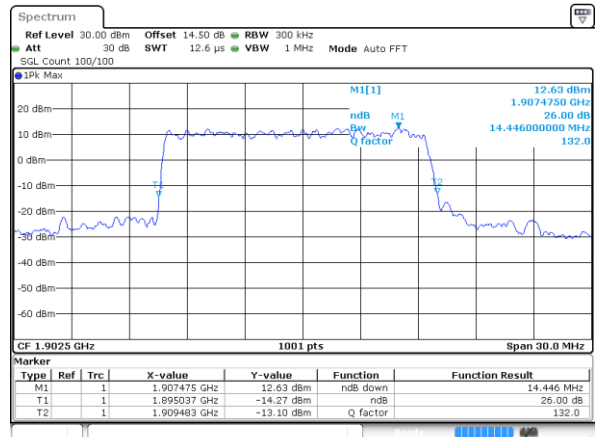
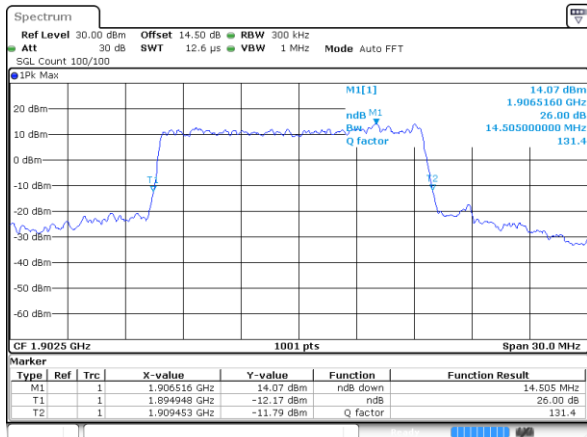

Date: 31 JUL 2020 05:04:56

Date: 31 JUL 2020 05:05:25



FR1 n2 / 15MHz / DFT-S OFDM

64QAM

256QAM

Lowest Channel

Lowest Channel

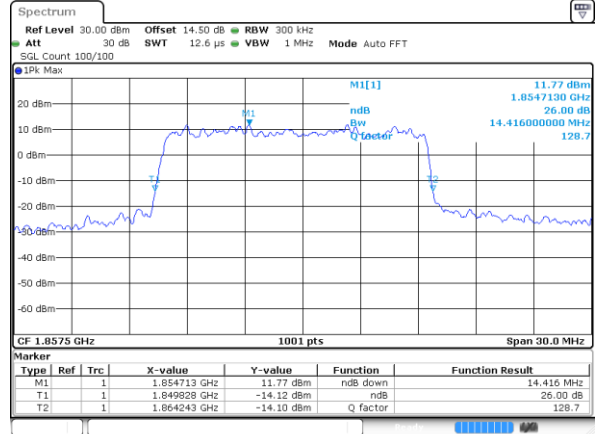
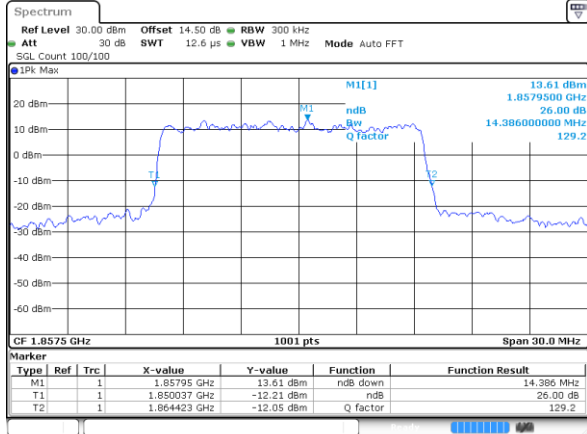

Date: 31 JUL 2020 04:40:13

Date: 31 JUL 2020 04:41:28

Middle Channel

Middle Channel

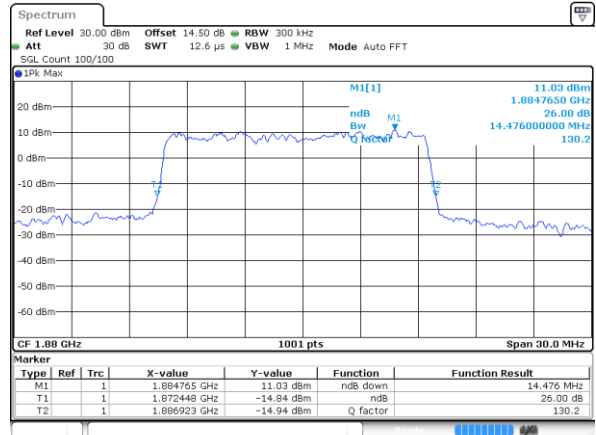
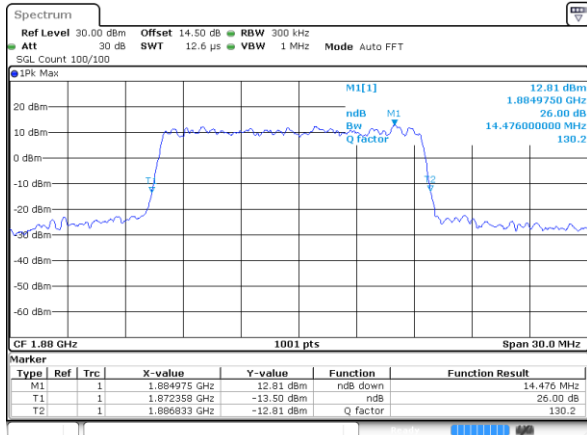

Date: 31 JUL 2020 04:51:12

Date: 31 JUL 2020 04:52:47

Highest Channel

Highest Channel

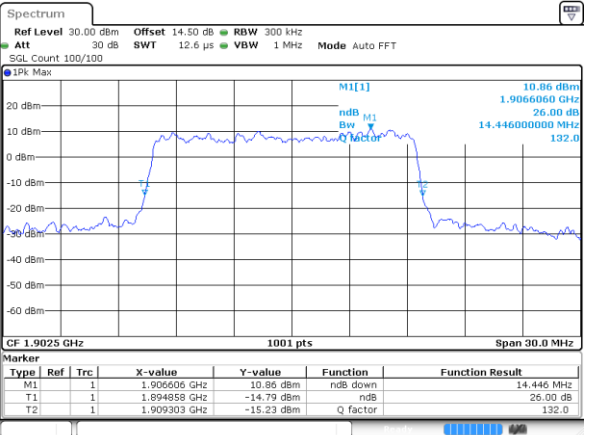
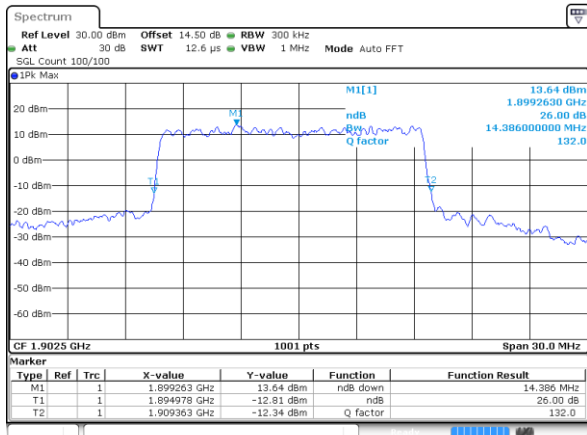

Date: 31 JUL 2020 05:20:46

Date: 31 JUL 2020 04:53:40

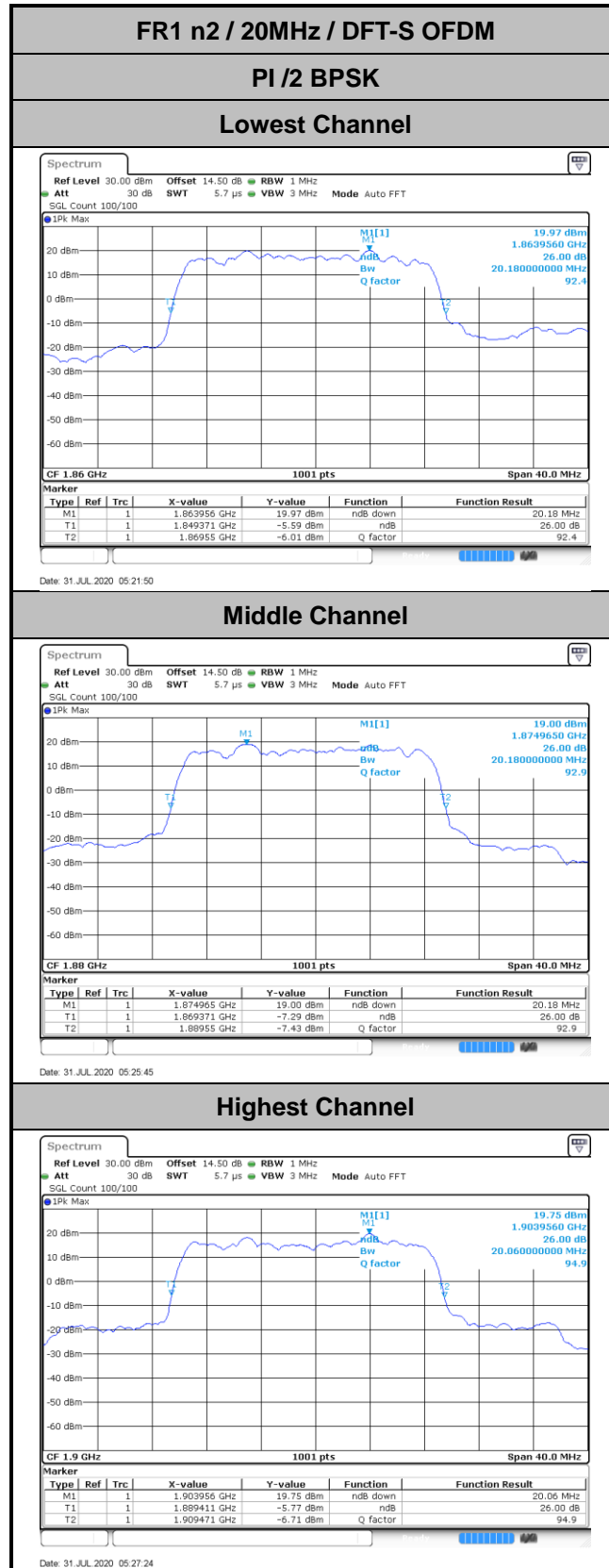



FR1 n2 / 20MHz / DFT-S OFDM

QPSK

16QAM

Lowest Channel

Lowest Channel

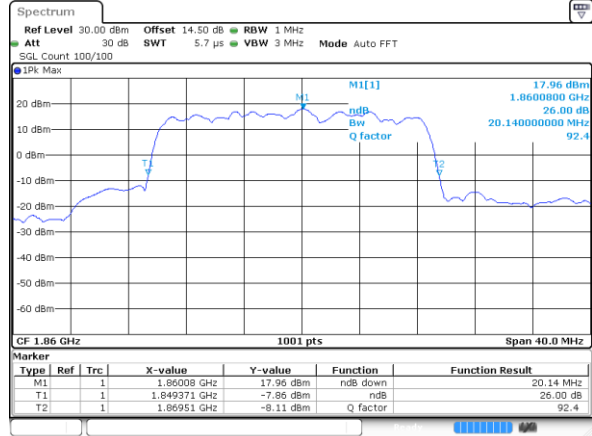
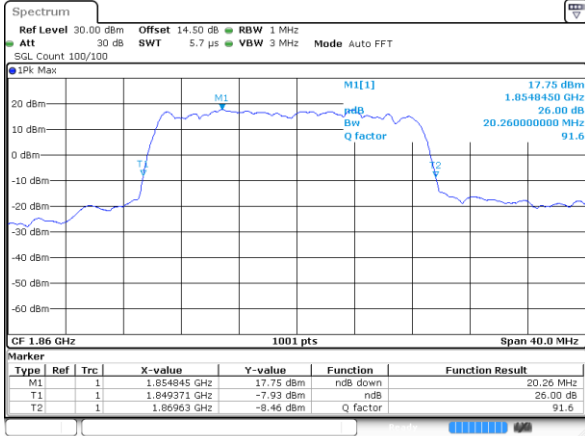

Date: 31 JUL 2020 05:23:19

Date: 31 JUL 2020 05:23:52

Middle Channel

Middle Channel

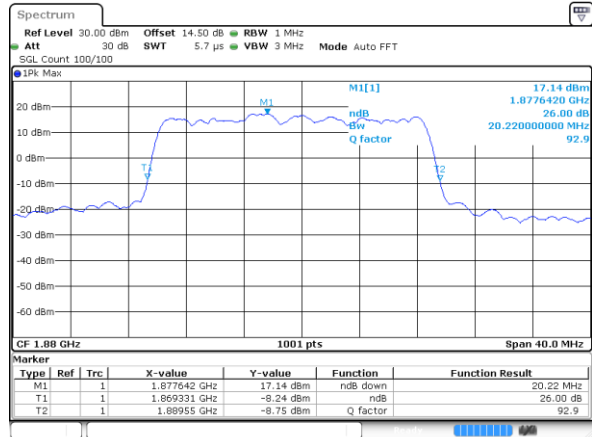
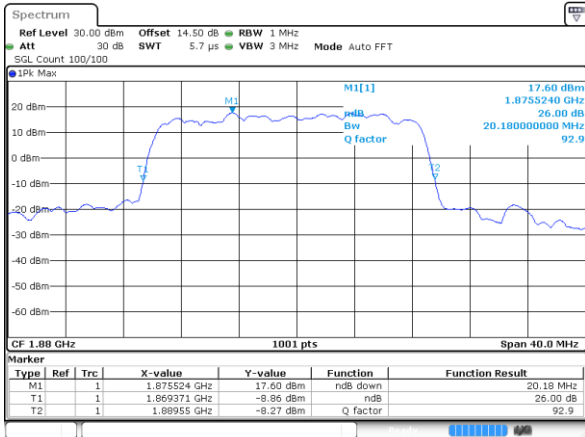

Date: 31 JUL 2020 05:26:02

Date: 31 JUL 2020 05:26:19

Highest Channel

Highest Channel

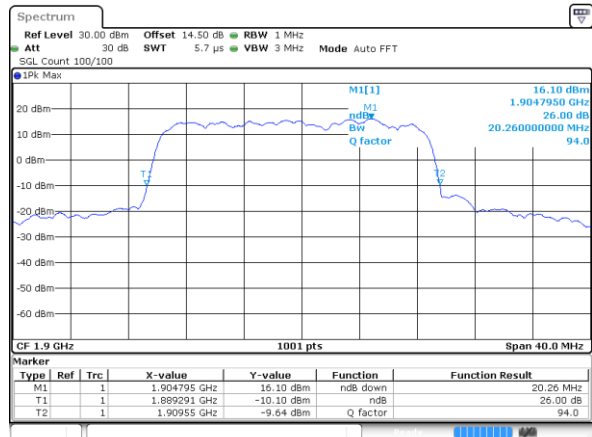
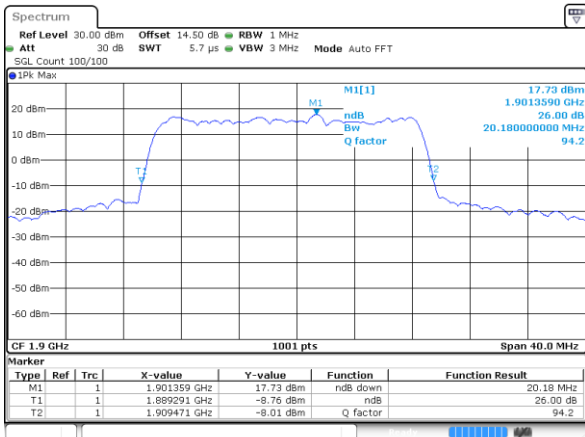

Date: 31 JUL 2020 05:28:52

Date: 31 JUL 2020 05:29:16



FR1 n2 / 20MHz / DFT-S OFDM

64QAM

256QAM

Lowest Channel

Lowest Channel

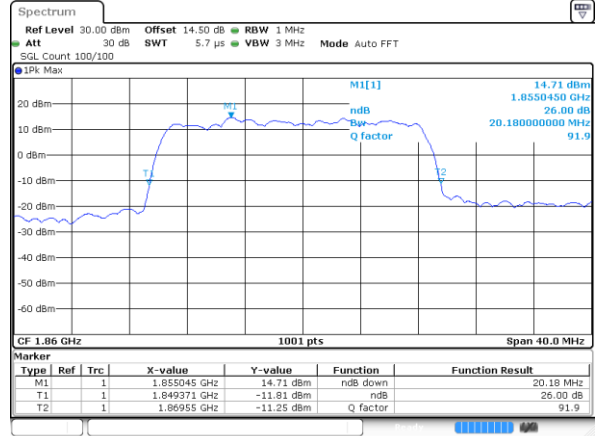
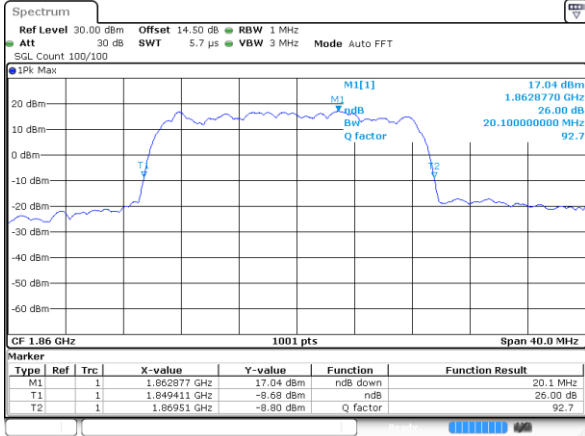

Date: 31 JUL 2020 05:24:53

Date: 31 JUL 2020 05:56:35

Middle Channel

Middle Channel

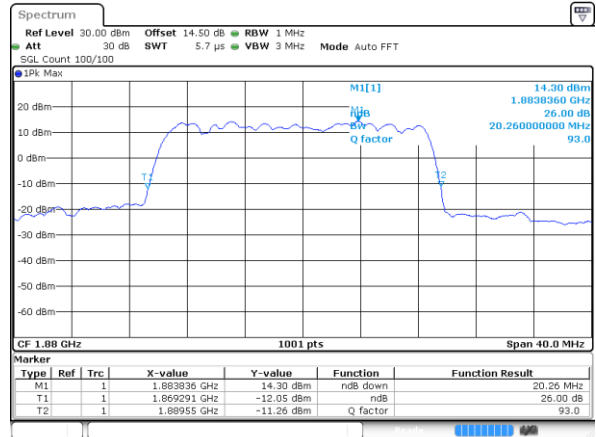
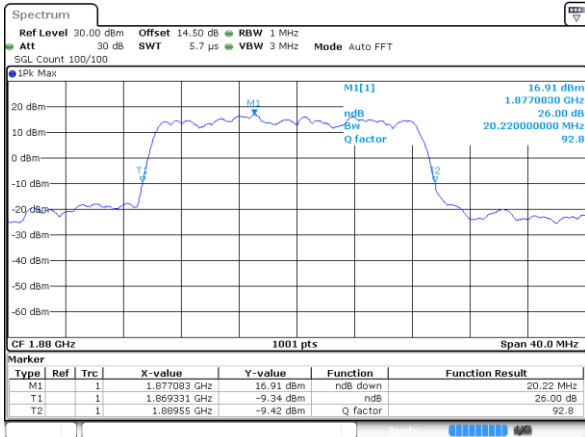

Date: 31 JUL 2020 05:26:37

Date: 31 JUL 2020 05:58:21

Highest Channel

Highest Channel

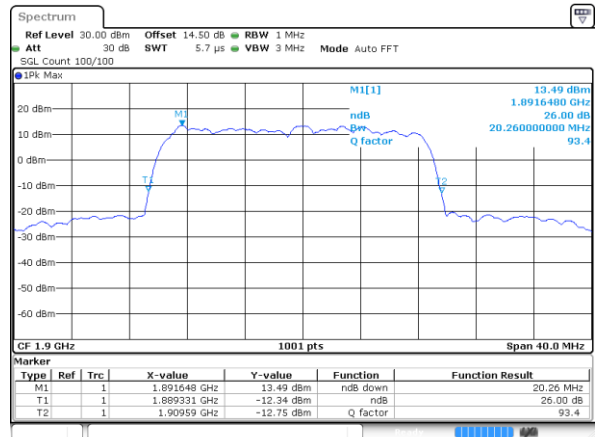
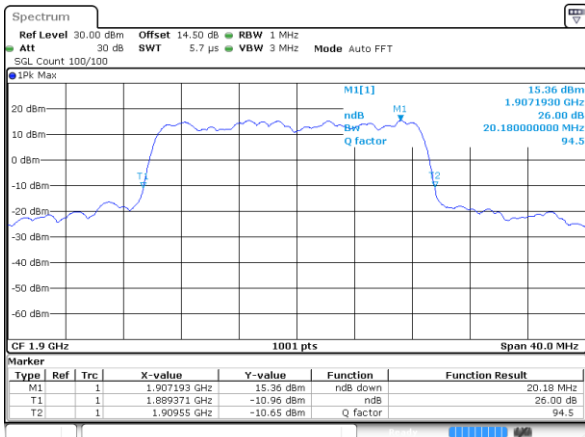

Date: 31 JUL 2020 05:30:23

Date: 31 JUL 2020 05:59:38



Occupied Bandwidth

Mode	FR1 n2 : 99%OBW(MHz) / DFT-S OFDM							
BW	5MHz		10MHz		15MHz		20MHz	
Mod.	PI/2 BPSK		PI/2 BPSK		PI/2 BPSK		PI/2 BPSK	
Lowest CH	4.49		9.03		13.52		18.58	
Middle CH	4.47		9.03		13.46		18.38	
Highest CH	4.50		9.09		13.49		18.38	
Mode	FR1 n2 : 99%OBW (MHz) / DFT-S OFDM							
BW	5MHz		10MHz		15MHz		20MHz	
Mod.	QPSK	16QAM	QPSK	16QAM	QPSK	16QAM	QPSK	16QAM
Lowest CH	4.50	4.50	9.05	9.05	13.52	13.46	18.34	18.58
Middle CH	4.50	4.48	9.05	9.03	13.46	13.46	18.30	18.42
Highest CH	4.50	4.48	9.05	9.05	13.49	13.49	18.26	18.38
Mode	FR1 n2 : 99%OBW (MHz) / DFT-S OFDM							
BW	5MHz		10MHz		15MHz		20MHz	
Mod.	64QAM	256QAM	64QAM	256QAM	64QAM	256QAM	64QAM	256QAM
Lowest CH	4.49	4.51	9.01	9.03	13.46	13.40	18.34	18.34
Middle CH	4.54	4.47	9.01	9.03	13.49	13.46	18.26	18.42
Highest CH	4.50	4.47	8.97	9.07	13.49	13.49	18.34	18.50

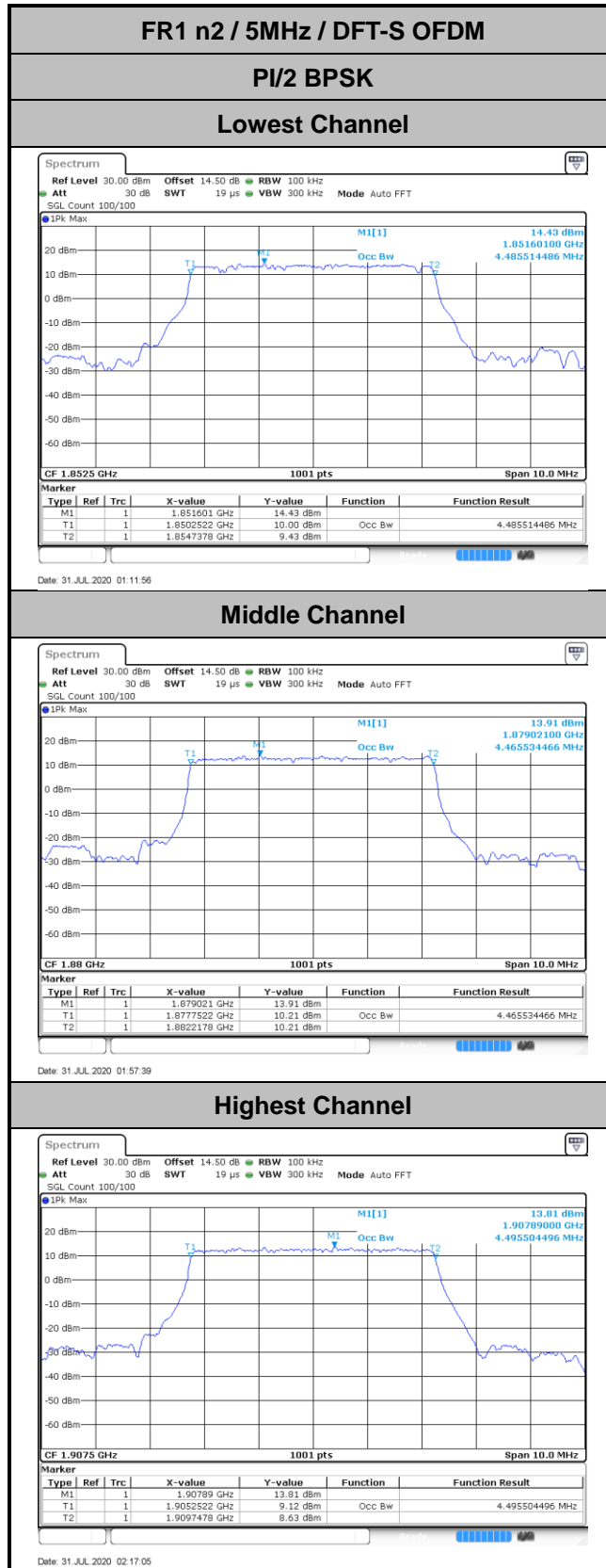



FR1 n2 / 5MHz / DFT-S OFDM

QPSK

16QAM

Lowest Channel

Lowest Channel

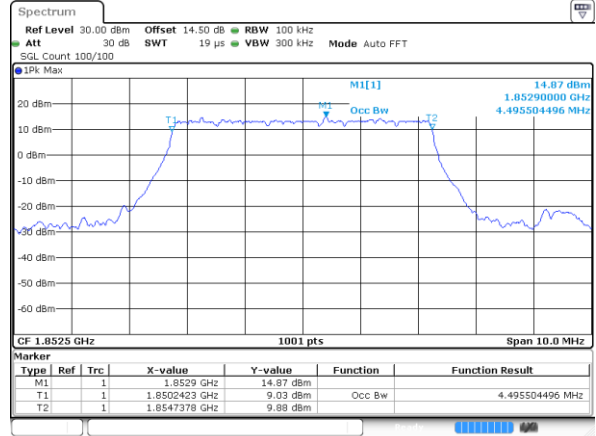
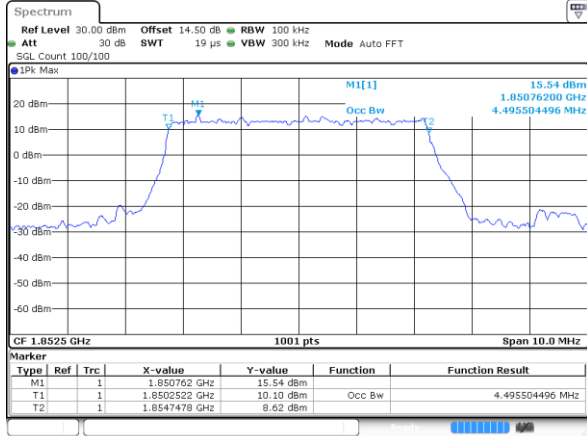

Date: 31 JUL 2020 01:14:12

Date: 31 JUL 2020 01:15:50

Middle Channel

Middle Channel

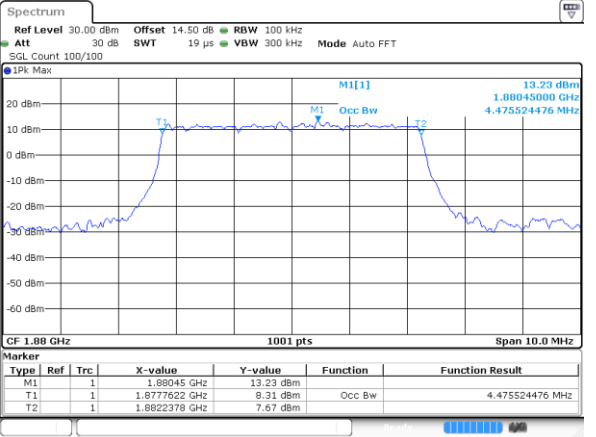
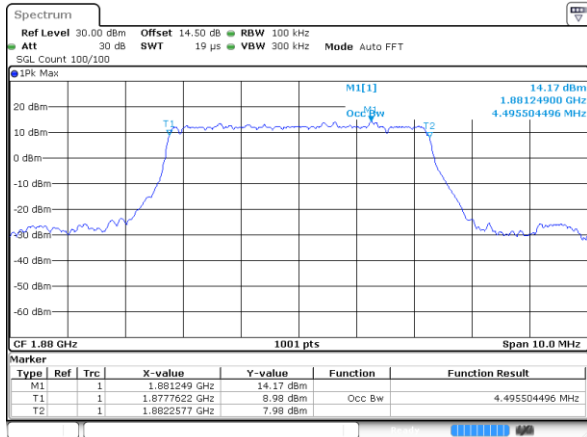

Date: 31 JUL 2020 01:58:02

Date: 31 JUL 2020 01:58:24

Highest Channel

Highest Channel

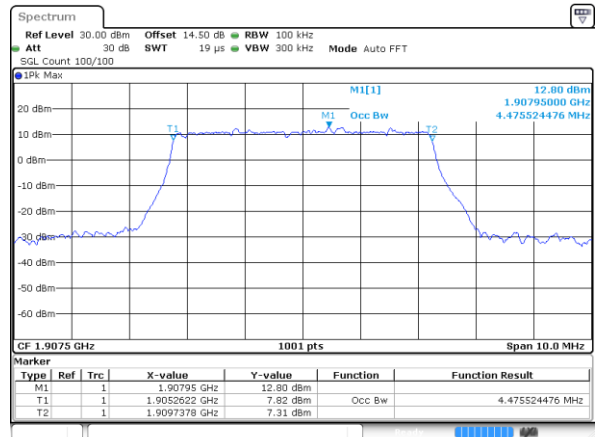
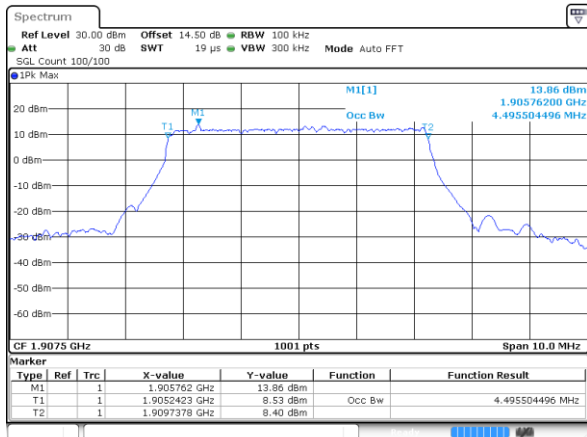

Date: 31 JUL 2020 02:19:16

Date: 31 JUL 2020 02:19:26



FR1 n2 / 5MHz / DFT-S OFDM

64QAM

256QAM

Lowest Channel

Lowest Channel

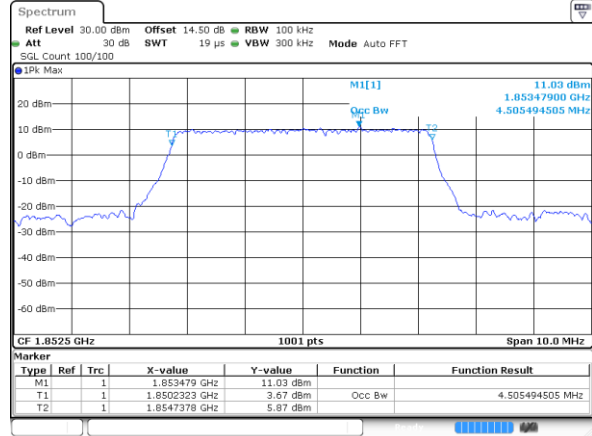
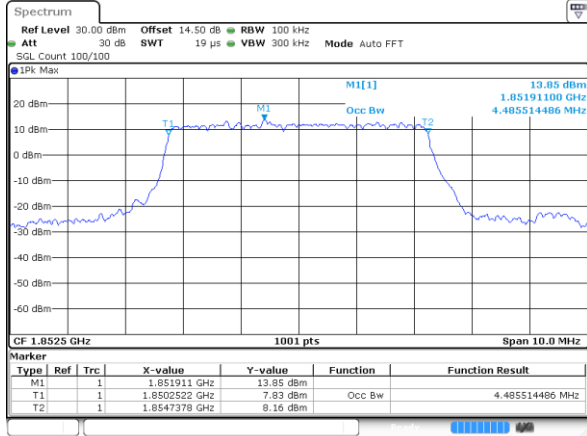

Date: 31 JUL 2020 01:17:50

Date: 31 JUL 2020 01:55:40

Middle Channel

Middle Channel

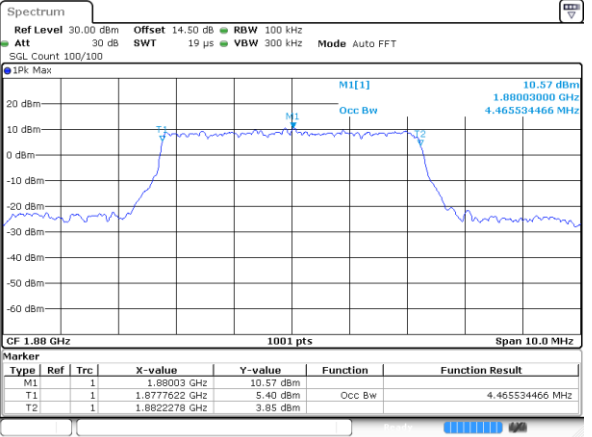
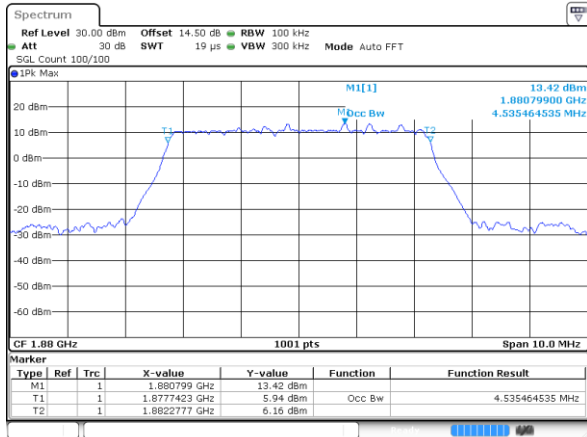

Date: 31 JUL 2020 01:58:45

Date: 31 JUL 2020 01:59:54

Highest Channel

Highest Channel

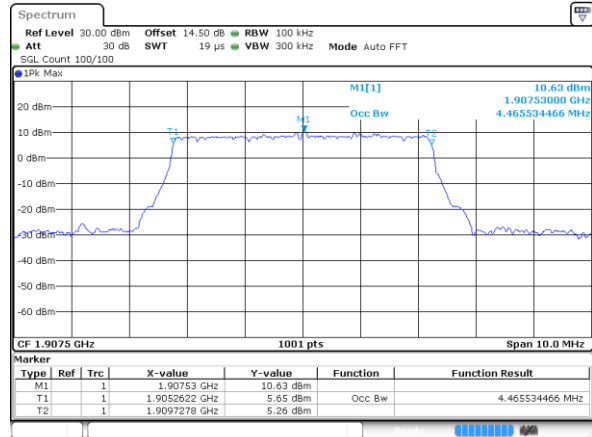
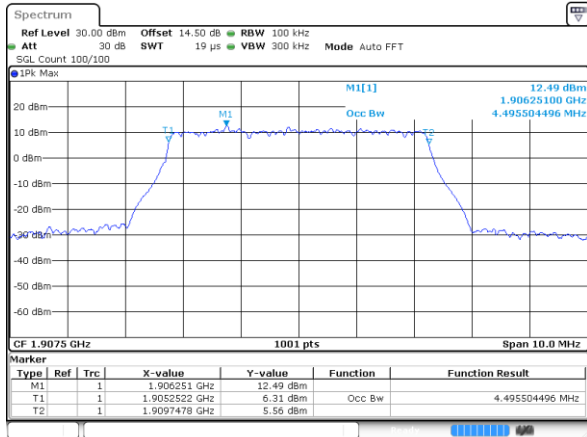

Date: 31 JUL 2020 02:26:04

Date: 31 JUL 2020 02:24:39

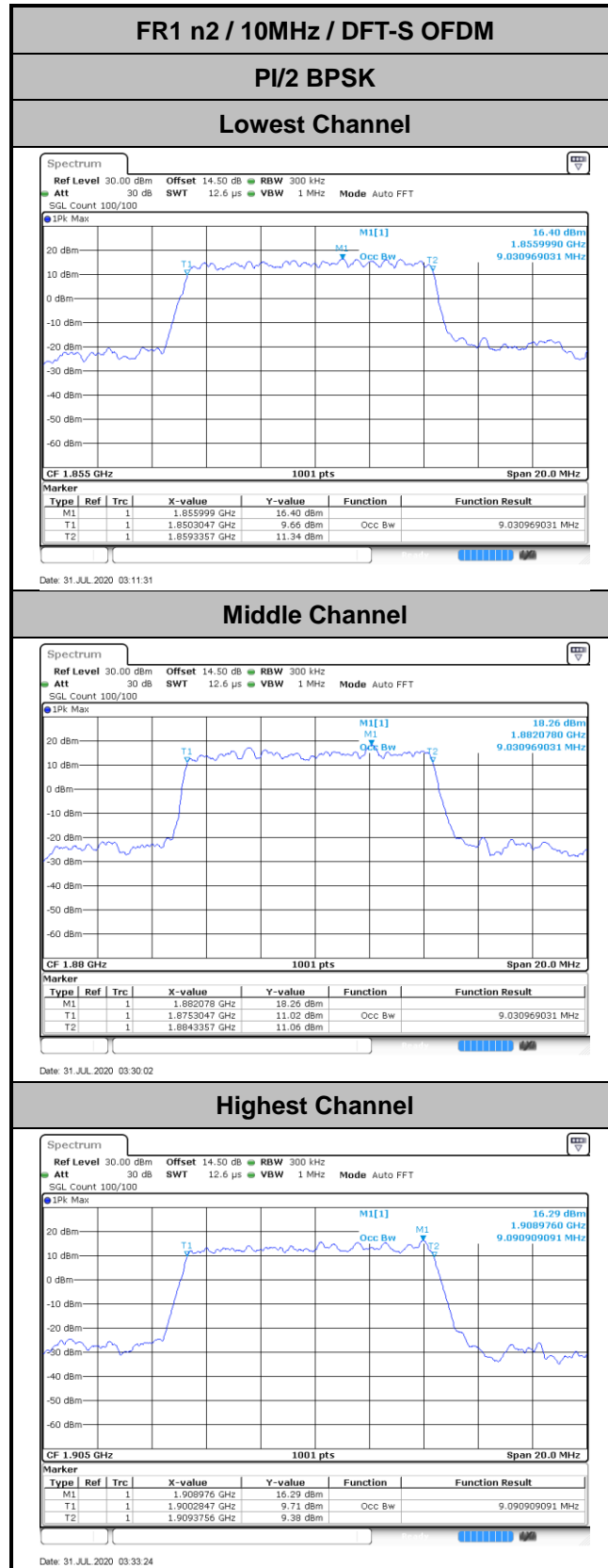



FR1 n2 / 10MHz / DFT-S OFDM

QPSK

16QAM

Lowest Channel

Lowest Channel

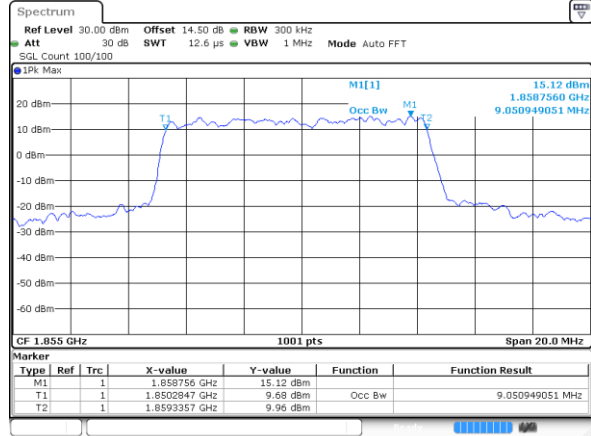
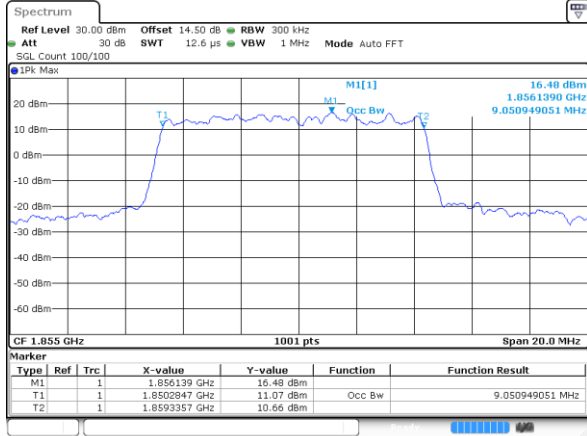

Date: 31 JUL 2020 03:14:23

Date: 31 JUL 2020 03:14:38

Middle Channel

Middle Channel

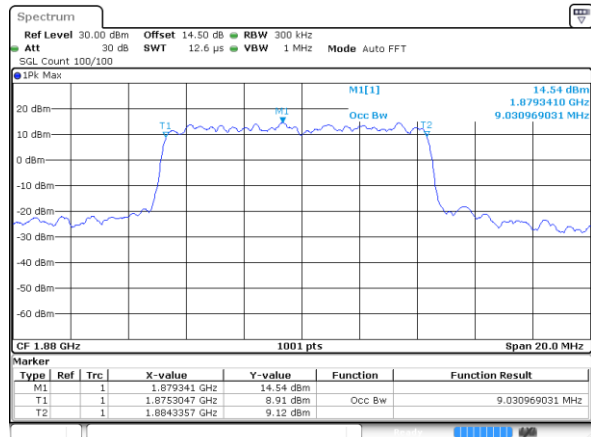
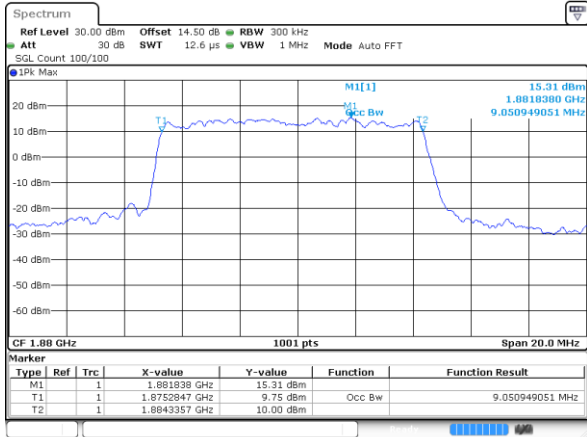

Date: 31 JUL 2020 03:30:20

Date: 31 JUL 2020 03:30:36

Highest Channel

Highest Channel

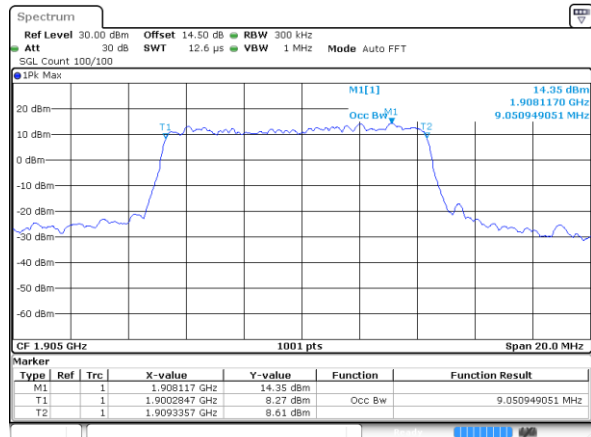
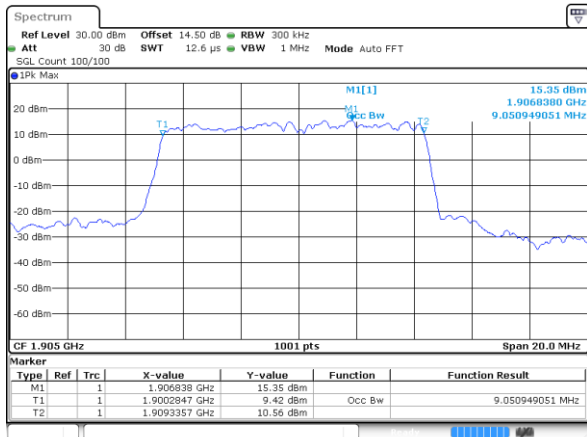

Date: 31 JUL 2020 03:35:26

Date: 31 JUL 2020 03:36:31