

01_GSM850_GPRS (1 Tx slot)_Left Cheek_Ch189

Communication System: GSM850; Frequency: 836.4 MHz; Duty Cycle: 1:8.3

Medium: HSL_850_180618 Medium parameters used : $f = 836.4$ MHz; $\sigma = 0.896$ S/m; $\epsilon_r = 41.447$; $\rho = 1000$ kg/m³

Ambient Temperature : 23.4 °C ; Liquid Temperature : 22.4 °C

DASY5 Configuration

- Probe: EX3DV4 - SN3976; ConvF(10.19, 10.19, 10.19) @ 836.4 MHz; Calibrated: 2018/1/23
- Sensor-Surface: 1.4mm (Mechanical Surface Detection)
- Electronics: DAE4 Sn778; Calibrated: 2018/5/25
- Phantom: SAM_Right; Type: QD000P40CD; Serial: S/N:1796
- Measurement SW: DASY52, Version 52.10 (1); SEMCAD X Version 14.6.11 (7439)

Area Scan (71x121x1): Interpolated grid: dx=1.500 mm, dy=1.500 mm

Maximum value of SAR (interpolated) = 0.406 W/kg

Zoom Scan (5x5x7)/Cube 0: Measurement grid: dx=8mm, dy=8mm, dz=5mm

Reference Value = 21.66 V/m; Power Drift = -0.05 dB

Peak SAR (extrapolated) = 0.442 W/kg

SAR(1 g) = 0.343 W/kg; SAR(10 g) = 0.264 W/kg

Maximum value of SAR (measured) = 0.402 W/kg

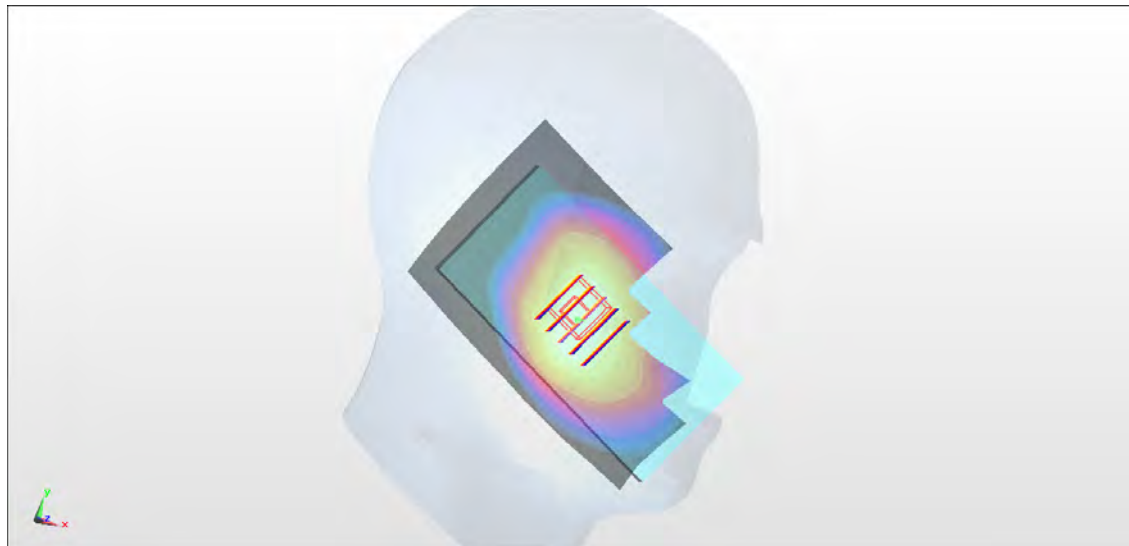
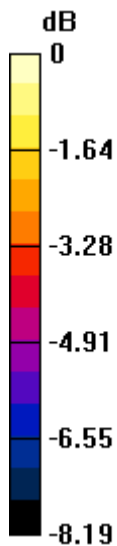

0 dB = 0.402 W/kg = -3.96 dBW/kg

02_GSM1900_GPRS (1 Tx slot)_Right Cheek_Ch512

Communication System: PCS; Frequency: 1850.2 MHz; Duty Cycle: 1:8.3

Medium: HSL_1900_180615 Medium parameters used : $f = 1850.2$ MHz; $\sigma = 1.366$ S/m; $\epsilon_r = 39.614$; $\rho = 1000$ kg/m³

Ambient Temperature : 23.2 °C ; Liquid Temperature : 22.2 °C

DASY5 Configuration:

- Probe: ES3DV3 - SN3169; ConvF(5.27, 5.27, 5.27) @ 1850.2 MHz; Calibrated: 2018/5/28
- Sensor-Surface: 3mm (Mechanical Surface Detection)
- Electronics: DAE4 Sn1424; Calibrated: 2018/1/18
- Phantom: SAM_Left; Type: QD000P40CD; Serial: TP:1477
- Measurement SW: DASY52, Version 52.10 (1); SEMCAD X Version 14.6.11 (7439)

Area Scan (71x121x1): Interpolated grid: dx=1.500 mm, dy=1.500 mm

Maximum value of SAR (interpolated) = 0.0685 W/kg

Zoom Scan (5x5x7)/Cube 0: Measurement grid: dx=8mm, dy=8mm, dz=5mm

Reference Value = 6.758 V/m; Power Drift = -0.18 dB

Peak SAR (extrapolated) = 0.0960 W/kg

SAR(1 g) = 0.058 W/kg; SAR(10 g) = 0.035 W/kg

Maximum value of SAR (measured) = 0.0695 W/kg

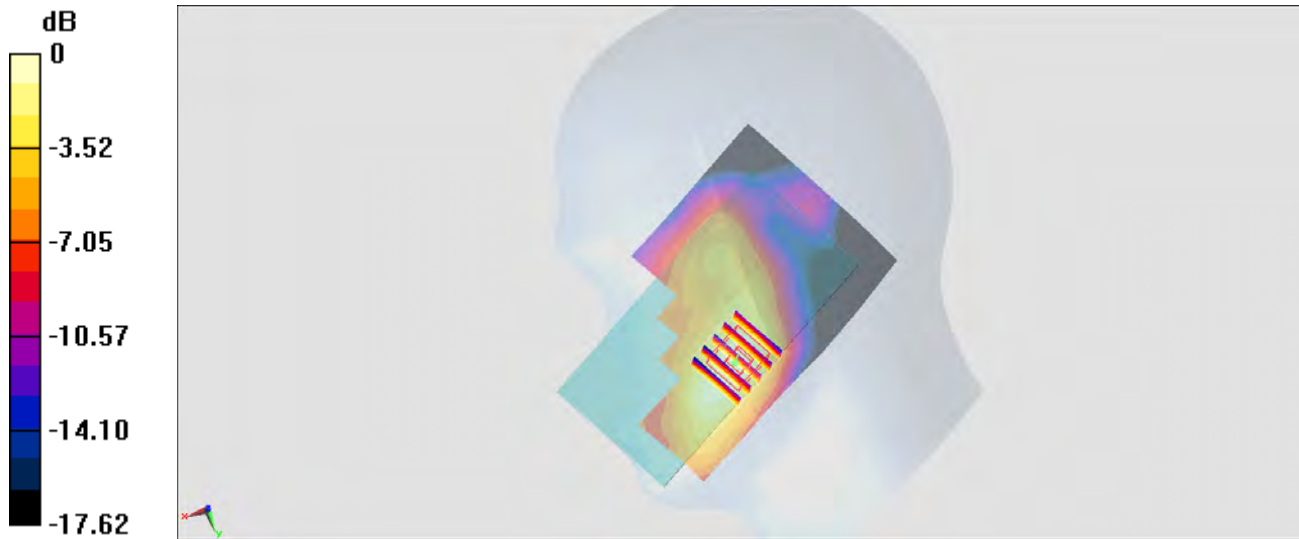

0 dB = 0.0695 W/kg = -11.58 dBW/kg

03_WCDMA II_RMC12.2Kbps_Right Cheek_0mm_Ch9262

Communication System: UMTS ; Frequency: 1852.4 MHz; Duty Cycle: 1:1

Medium: HSL_1900 Medium parameters used: $f = 1852.4$ MHz; $\sigma = 1.377$ S/m; $\epsilon_r = 41.314$; $\rho = 1000$ kg/m³

Ambient Temperature : 23.3 °C ; Liquid Temperature : 22.6 °C

DASY5 Configuration:

- Probe: EX3DV4 - SN3954; ConvF(8.41, 8.41, 8.41); Calibrated: 2018.1.31;
- Sensor-Surface: 1.4mm (Mechanical Surface Detection)
- Electronics: DAE4 Sn1210; Calibrated: 2018.5.28
- Phantom: SAM3; Type: SAM; Serial: TP-1839
- Measurement SW: DASY52, Version 52.8 (8); SEMCAD X Version 14.6.10 (7331)

Area Scan (71x121x1): Interpolated grid: dx=1.500 mm, dy=1.500 mm

Maximum value of SAR (interpolated) = 0.177 W/kg

Zoom Scan (5x5x7)/Cube 0: Measurement grid: dx=8mm, dy=8mm, dz=5mm

Reference Value = 2.799 V/m; Power Drift = 0.11 dB

Peak SAR (extrapolated) = 0.208 W/kg

SAR(1 g) = 0.127 W/kg; SAR(10 g) = 0.076 W/kg

Maximum value of SAR (measured) = 0.171 W/kg

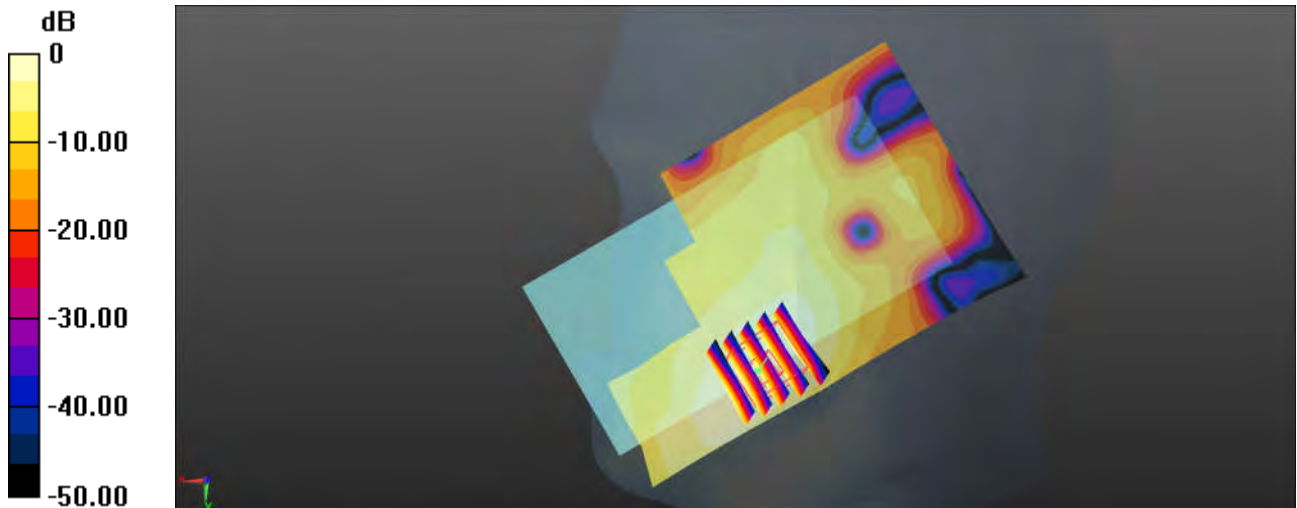

0 dB = 0.177 W/kg = -7.52 dBW/kg

04_WCDMA IV_RMC12.2Kbps_Right Cheek_0mm_Ch1513

Communication System: UMTS ; Frequency: 1752.6 MHz; Duty Cycle: 1:1

Medium: HSL_1750 Medium parameters used: $f = 1753$ MHz; $\sigma = 1.356$ S/m; $\epsilon_r = 40.64$; $\rho = 1000$

kg/m³

Ambient Temperature : 23.3 °C ; Liquid Temperature : 22.6 °C

DASY5 Configuration:

- Probe: EX3DV4 - SN3954; ConvF(8.65, 8.65, 8.65); Calibrated: 2018.1.31;
- Sensor-Surface: 1.4mm (Mechanical Surface Detection)
- Electronics: DAE4 Sn1338; Calibrated: 2017.12.4
- Phantom: SAM3; Type: SAM; Serial: TP-1839
- Measurement SW: DASY52, Version 52.8 (8); SEMCAD X Version 14.6.10 (7331)

Area Scan (71x121x1): Interpolated grid: dx=1.500 mm, dy=1.500 mm

Maximum value of SAR (interpolated) = 0.564 W/kg

Zoom Scan (5x5x7)/Cube 0: Measurement grid: dx=8mm, dy=8mm, dz=5mm

Reference Value = 5.137 V/m; Power Drift = 0.05 dB

Peak SAR (extrapolated) = 0.630 W/kg

SAR(1 g) = 0.402 W/kg; SAR(10 g) = 0.243 W/kg

Maximum value of SAR (measured) = 0.522 W/kg

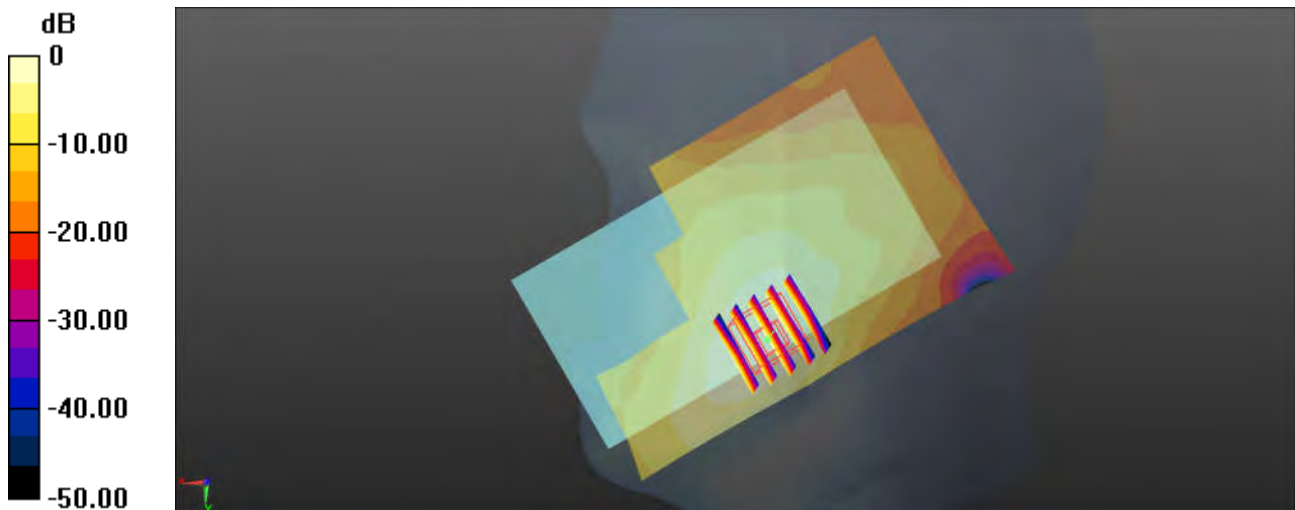

0 dB = 0.564 W/kg = -2.49 dBW/kg

05_WCDMA V_RMC12.2Kbps_Left Cheek_0mm_Ch4233

Communication System: UMTS ; Frequency: 846.6 MHz; Duty Cycle: 1:1

Medium: HSL_835 Medium parameters used: $f = 847$ MHz; $\sigma = 0.926$ S/m; $\epsilon_r = 42.625$; $\rho = 1000$ kg/m³

Ambient Temperature : 23.4 °C ; Liquid Temperature : 22.8 °C

DASY5 Configuration:

- Probe: EX3DV4 - SN3954; ConvF(10.2, 10.2, 10.2); Calibrated: 2018.1.31;
- Sensor-Surface: 1.4mm (Mechanical Surface Detection)
- Electronics: DAE4 Sn1210; Calibrated: 2018.5.28
- Phantom: SAM3; Type: SAM; Serial: TP-1839
- Measurement SW: DASY52, Version 52.8 (8); SEMCAD X Version 14.6.10 (7331)

Area Scan (71x121x1): Interpolated grid: dx=1.500 mm, dy=1.500 mm

Maximum value of SAR (interpolated) = 1.04 W/kg

Zoom Scan (5x5x7)/Cube 0: Measurement grid: dx=8mm, dy=8mm, dz=5mm

Reference Value = 32.97 V/m; Power Drift = -0.05 dB

Peak SAR (extrapolated) = 1.32 W/kg

SAR(1 g) = 0.843 W/kg; SAR(10 g) = 0.577 W/kg

Maximum value of SAR (measured) = 1.09 W/kg

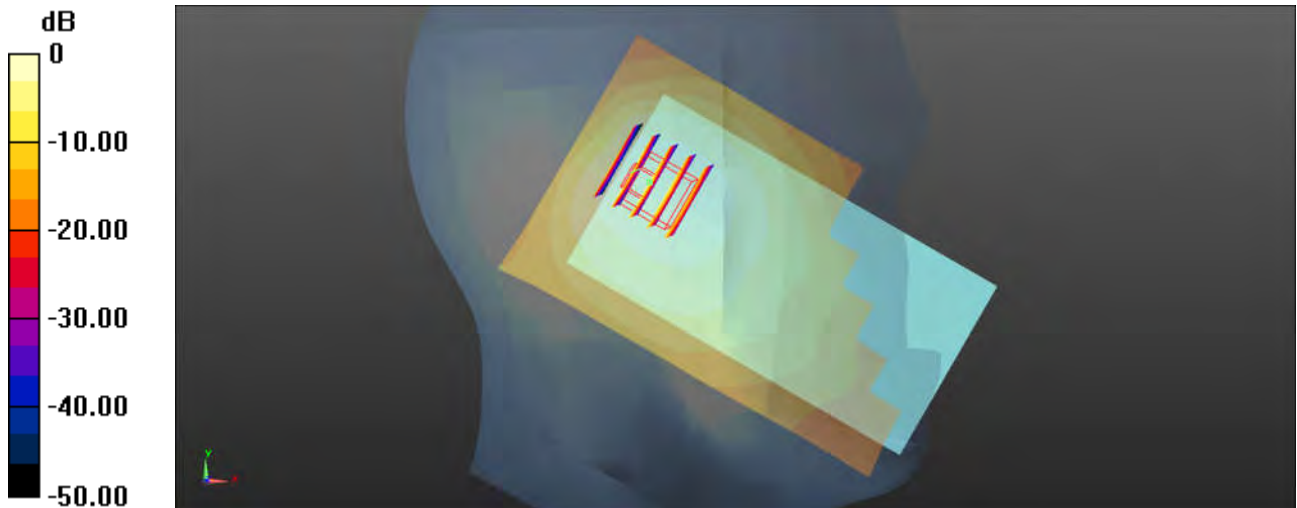

0 dB = 1.04 W/kg = 0.17 dBW/kg

06_LTE Band 2_20M_QPSK_1RB_49Offset_Right Cheek_0mm_Ch18700

Communication System: LTE ; Frequency: 1860 MHz;Duty Cycle: 1:1

Medium: HSL_1900 Medium parameters used: $f = 1860$ MHz; $\sigma = 1.386$ S/m; $\epsilon_r = 41.292$; $\rho = 1000$ kg/m³

Ambient Temperature : 23.3 °C ; Liquid Temperature : 22.6 °C

DASY5 Configuration:

- Probe: EX3DV4 - SN3954; ConvF(8.41, 8.41, 8.41); Calibrated: 2018.1.31;
- Sensor-Surface: 1.4mm (Mechanical Surface Detection)
- Electronics: DAE4 Sn1210; Calibrated: 2018.5.28
- Phantom: SAM3; Type: SAM; Serial: TP-1839
- Measurement SW: DASY52, Version 52.8 (8); SEMCAD X Version 14.6.10 (7331)

Ch18700/Area Scan (71x121x1): Interpolated grid: dx=1.500 mm, dy=1.500 mm

Maximum value of SAR (interpolated) = 0.176 W/kg

Ch18700/Zoom Scan (5x5x7)/Cube 0: Measurement grid: dx=8mm, dy=8mm, dz=5mm

Reference Value = 3.017 V/m; Power Drift = 0.02 dB

Peak SAR (extrapolated) = 0.195 W/kg

SAR(1 g) = 0.135 W/kg; SAR(10 g) = 0.087 W/kg

Maximum value of SAR (measured) = 0.167 W/kg

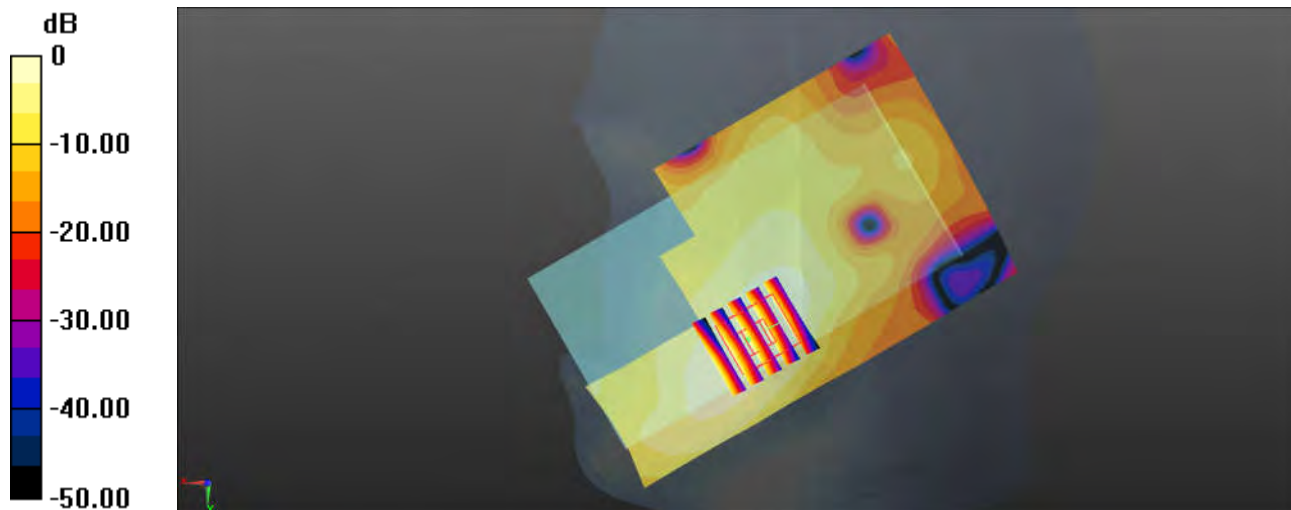

0 dB = 0.176 W/kg = -7.54 dBW/kg

07_LTE Band 5_10M_QPSK_1RB_25Offset_Right Cheek_0mm_Ch20525

Communication System: LTE ; Frequency: 836.5 MHz;Duty Cycle: 1:1

Medium: HSL_835 Medium parameters used: $f = 836.5$ MHz; $\sigma = 0.916$ S/m; $\epsilon_r = 42.751$; $\rho = 1000$ kg/m³

Ambient Temperature : 23.4 °C ; Liquid Temperature : 22.8 °C

DASY5 Configuration:

- Probe: EX3DV4 - SN3954; ConvF(10.2, 10.2, 10.2); Calibrated: 2018.1.31;
- Sensor-Surface: 1.4mm (Mechanical Surface Detection)
- Electronics: DAE4 Sn1210; Calibrated: 2018.5.28
- Phantom: SAM3; Type: SAM; Serial: TP-1839
- Measurement SW: DASY52, Version 52.8 (8); SEMCAD X Version 14.6.10 (7331)

Area Scan (71x121x1): Interpolated grid: dx=1.500 mm, dy=1.500 mm
Maximum value of SAR (interpolated) = 0.932 W/kg

Zoom Scan (5x5x7)/Cube 0: Measurement grid: dx=8mm, dy=8mm, dz=5mm
Reference Value = 33.35 V/m; Power Drift = 0.01 dB
Peak SAR (extrapolated) = 1.79 W/kg
SAR(1 g) = 0.676 W/kg; SAR(10 g) = 0.413 W/kg
Maximum value of SAR (measured) = 1.03 W/kg

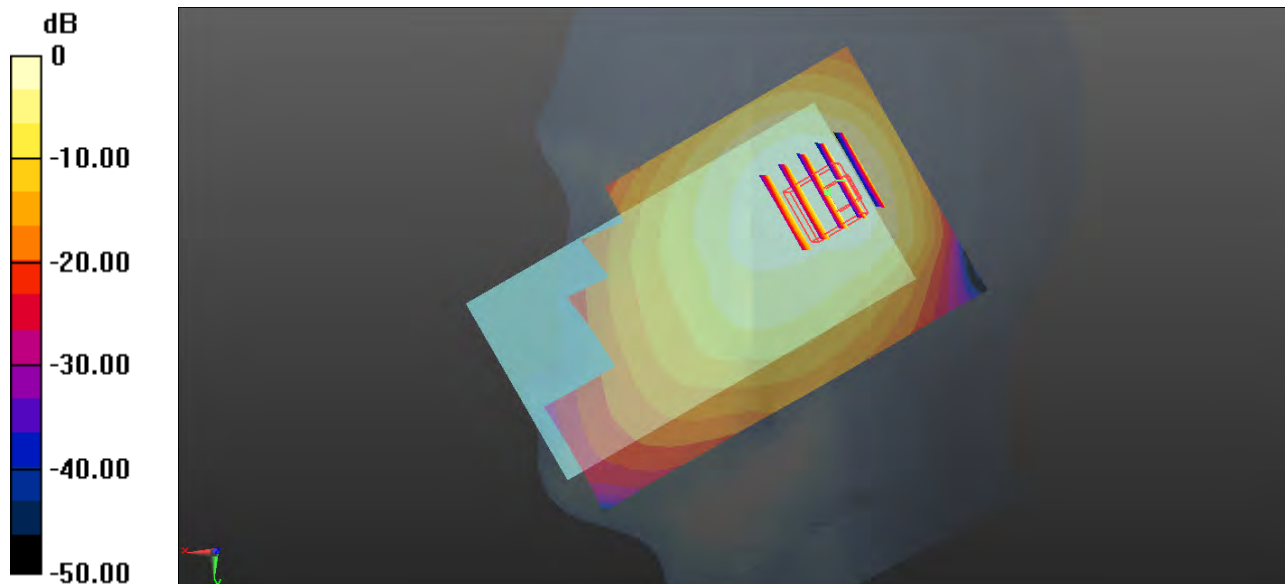

0 dB = 0.932 W/kg = -0.31 dBW/kg

08_LTE Band 7_20M_QPSK_1RB_49Offset_Left Cheek_0mm_Ch21350

Communication System: LTE ; Frequency: 2560 MHz;Duty Cycle: 1:1

Medium: HSL_2600 Medium parameters used: $f = 2560$ MHz; $\sigma = 1.973$ S/m; $\epsilon_r = 38.542$; $\rho = 1000$ kg/m³

Ambient Temperature : 23.3 °C ; Liquid Temperature : 22.8 °C

DASY5 Configuration:

- Probe: EX3DV4 - SN3954; ConvF(7.31, 7.31, 7.31); Calibrated: 2018.1.31;
- Sensor-Surface: 1.4mm (Mechanical Surface Detection)
- Electronics: DAE4 Sn1338; Calibrated: 2017.12.4
- Phantom: SAM3; Type: SAM; Serial: TP-1839
- Measurement SW: DASY52, Version 52.8 (8); SEMCAD X Version 14.6.10 (7331)

Area Scan (81x151x1): Interpolated grid: dx=1.200 mm, dy=1.200 mmMaximum value of SAR (interpolated) = 0.434 W/kg

Zoom Scan (7x7x7)/Cube 0: Measurement grid: dx=5mm, dy=5mm, dz=5mm

Reference Value = 5.407 V/m; Power Drift = 0.02 dB

Peak SAR (extrapolated) = 0.504 W/kg

SAR(1 g) = 0.286 W/kg; SAR(10 g) = 0.150 W/kg

Maximum value of SAR (measured) = 0.402 W/kg

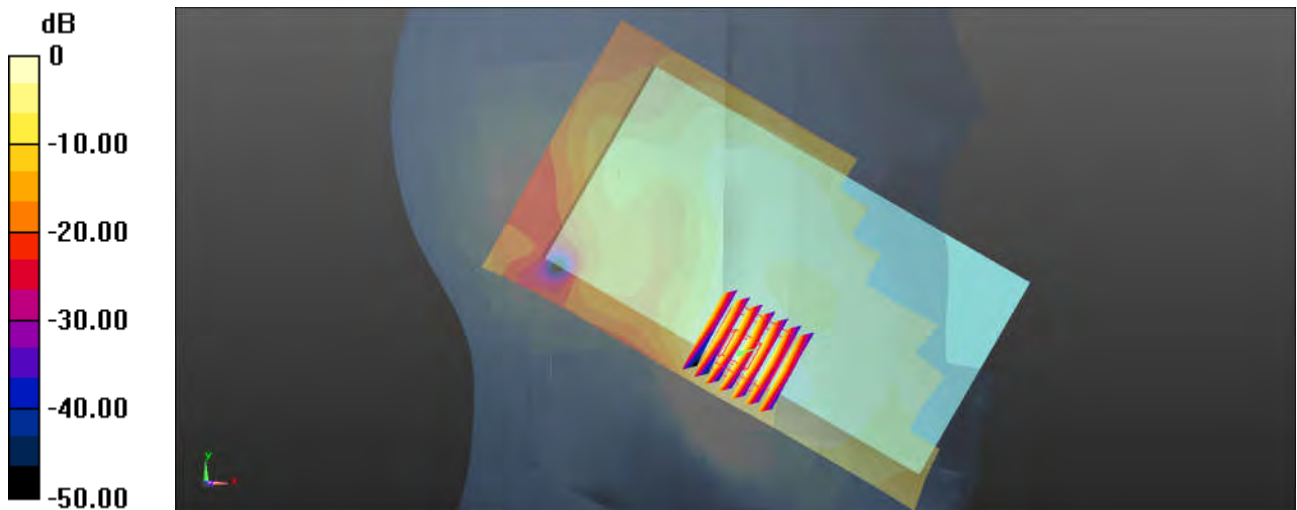

0 dB = 0.434 W/kg = -3.63 dBW/kg

09_LTE Band 12_10M_QPSK_1RB_25Offset_Right Cheek_0mm_Ch23095

Communication System: LTE ; Frequency: 707.5 MHz;Duty Cycle: 1:1

Medium: HSL_750 Medium parameters used: $f = 707.5 \text{ MHz}$; $\sigma = 0.864 \text{ S/m}$; $\epsilon_r = 43.016$; $\rho = 1000$

kg/m^3

Ambient Temperature : $23.3 \text{ }^\circ\text{C}$; Liquid Temperature : $22.8 \text{ }^\circ\text{C}$

DASY5 Configuration:

- Probe: ES3DV3 - SN3293; ConvF(6.47, 6.47, 6.47); Calibrated: 2017.9.25;
- Sensor-Surface: 3mm (Mechanical Surface Detection)
- Electronics: DAE4 Sn1279; Calibrated: 2018.1.3
- Phantom: SAM1; Type: SAM; Serial: TP-1697
- Measurement SW: DASY52, Version 52.8 (8); SEMCAD X Version 14.6.10 (7372)

Area Scan (71x121x1): Interpolated grid: $dx=1.500 \text{ mm}$, $dy=1.500 \text{ mm}$

Maximum value of SAR (interpolated) = 0.414 W/kg

Zoom Scan (5x5x7)/Cube 0: Measurement grid: $dx=8\text{mm}$, $dy=8\text{mm}$, $dz=5\text{mm}$

Reference Value = 21.67 V/m ; Power Drift = 0.08 dB

Peak SAR (extrapolated) = 0.726 W/kg

SAR(1 g) = 0.381 W/kg ; SAR(10 g) = 0.246 W/kg

Maximum value of SAR (measured) = 0.539 W/kg

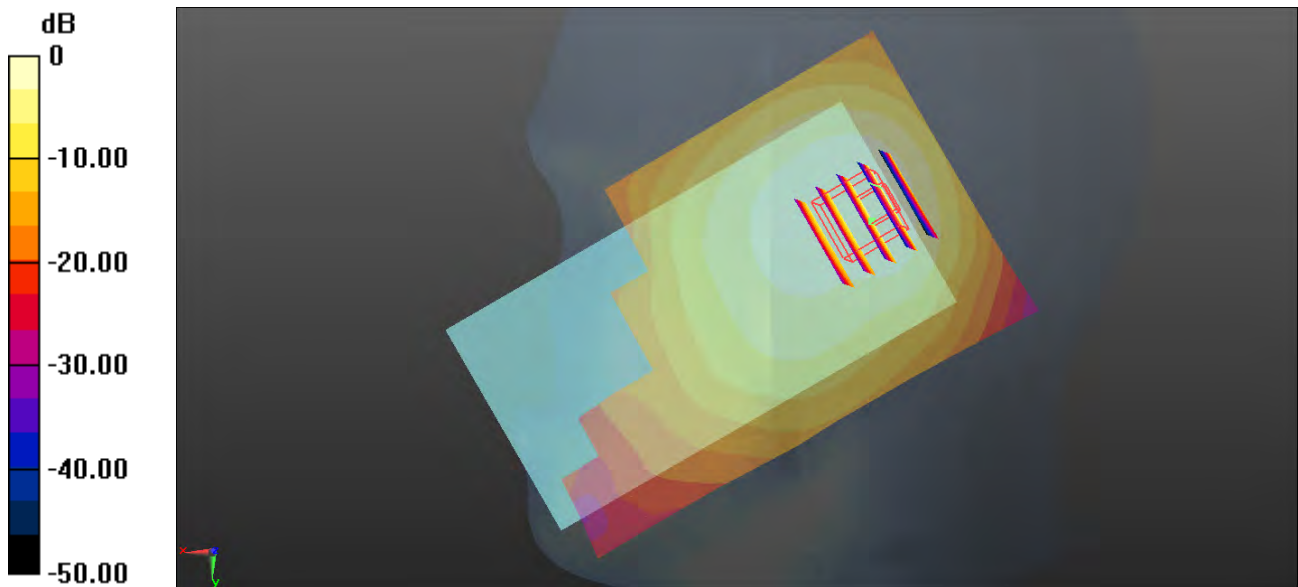

$0 \text{ dB} = 0.414 \text{ W/kg} = -3.83 \text{ dBW/kg}$

10_LTE Band 13_10M_QPSK_1RB_25Offset_Right Cheek_0mm_Ch23230

Communication System: LTE ; Frequency: 782 MHz; Duty Cycle: 1:1

Medium: HSL_750 Medium parameters used: $f = 782 \text{ MHz}$; $\sigma = 0.930 \text{ S/m}$; $\epsilon_r = 42.008$; $\rho = 1000$

kg/m^3

Ambient Temperature : $23.3 \text{ }^\circ\text{C}$; Liquid Temperature : $22.8 \text{ }^\circ\text{C}$

DASY5 Configuration:

- Probe: ES3DV3 - SN3293; ConvF(6.47, 6.47, 6.47); Calibrated: 2017.9.25;
- Sensor-Surface: 3mm (Mechanical Surface Detection)
- Electronics: DAE4 Sn1279; Calibrated: 2018.1.3
- Phantom: SAM1; Type: SAM; Serial: TP-1697
- Measurement SW: DASY52, Version 52.8 (8); SEMCAD X Version 14.6.10 (7372)

Area Scan (71x121x1): Interpolated grid: $dx=1.500 \text{ mm}$, $dy=1.500 \text{ mm}$

Maximum value of SAR (interpolated) = 0.695 W/kg

Zoom Scan (5x5x7)/Cube 0: Measurement grid: $dx=8\text{mm}$, $dy=8\text{mm}$, $dz=5\text{mm}$

Reference Value = 27.48 V/m ; Power Drift = 0.02 dB

Peak SAR (extrapolated) = 1.22 W/kg

SAR(1 g) = 0.581 W/kg ; SAR(10 g) = 0.356 W/kg

Maximum value of SAR (measured) = 0.883 W/kg

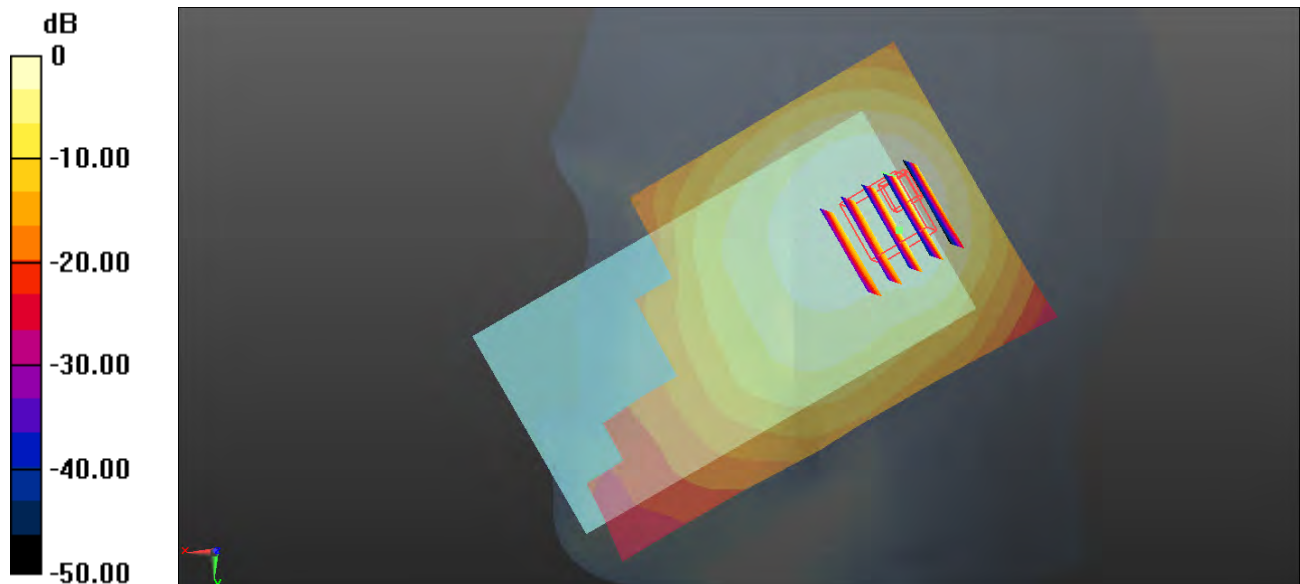

$0 \text{ dB} = 0.695 \text{ W/kg} = -1.58 \text{ dBW/kg}$

11_LTE Band 66_20M_QPSK_1RB_49Offset_Right

Cheek_0mm_Ch132572

Communication System: LTE ; Frequency: 1770 MHz;Duty Cycle: 1:1

Medium: HSL_1750 Medium parameters used: $f = 1770$ MHz; $\sigma = 1.372$ S/m; $\epsilon_r = 40.594$; $\rho = 1000$ kg/m³

Ambient Temperature : 23.3 °C ; Liquid Temperature : 22.6 °C

DASY5 Configuration:

- Probe: EX3DV4 - SN3954; ConvF(8.65, 8.65, 8.65); Calibrated: 2018.1.31;
- Sensor-Surface: 1.4mm (Mechanical Surface Detection)
- Electronics: DAE4 Sn1338; Calibrated: 2017.12.4
- Phantom: SAM3; Type: SAM; Serial: TP-1839
- Measurement SW: DASY52, Version 52.8 (8); SEMCAD X Version 14.6.10 (7331)

Area Scan (71x121x1): Interpolated grid: dx=1.500 mm, dy=1.500 mm Maximum value of SAR (interpolated) = 0.468 W/kg

Zoom Scan (5x5x7)/Cube 0: Measurement grid: dx=8mm, dy=8mm, dz=5mm

Reference Value = 3.009 V/m; Power Drift = 0.06 dB

Peak SAR (extrapolated) = 0.466 W/kg

SAR(1 g) = 0.337 W/kg; SAR(10 g) = 0.224 W/kg

Maximum value of SAR (measured) = 0.406 W/kg

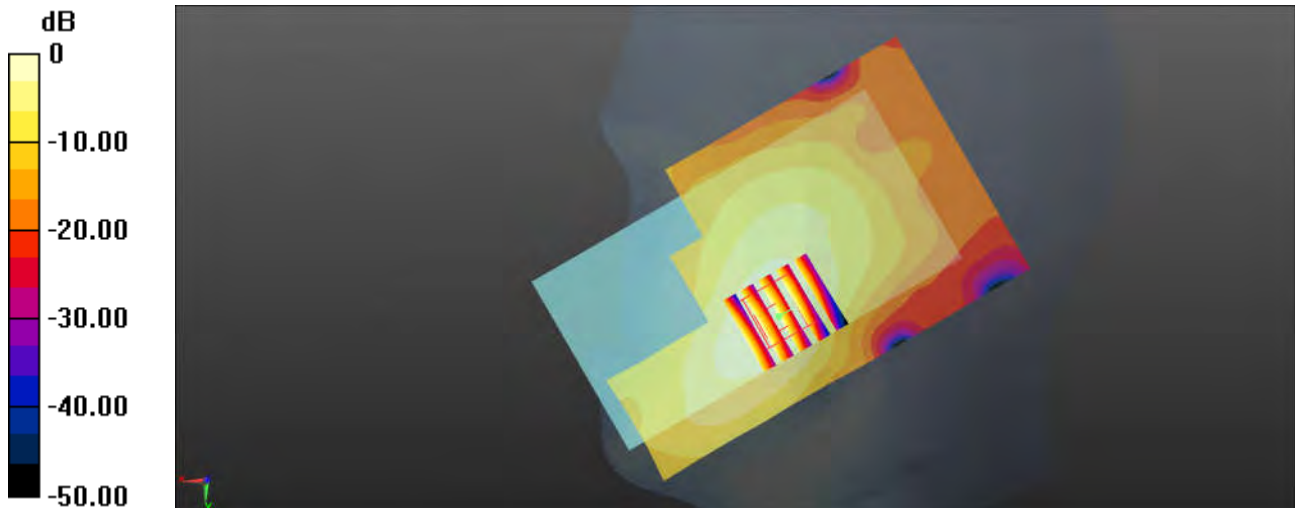

0 dB = 0.468 W/kg = -3.30 dBW/kg

12_LTE Band 38_20M_QPSK_1_49_Right Cheek_Ch38150

Communication System: LTE; Frequency: 2610 MHz; Duty Cycle: 1:1.59

Medium: HSL_2600_180616 Medium parameters used : $f = 2610$ MHz; $\sigma = 1.968$ S/m; $\epsilon_r = 37.843$; $\rho = 1000$ kg/m³

Ambient Temperature : 23.2 °C ; Liquid Temperature : 22.2 °C

DASY5 Configuration:

- Probe: ES3DV3 - SN3169; ConvF(4.5, 4.5, 4.5) @ 2610 MHz; Calibrated: 2018/5/28
- Sensor-Surface: 3mm (Mechanical Surface Detection)
- Electronics: DAE4 Sn1424; Calibrated: 2018/1/18
- Phantom: SAM_Right; Type: SAM; Serial: TP:1479
- Measurement SW: DASY52, Version 52.10 (1); SEMCAD X Version 14.6.11 (7439)

Area Scan (91x151x1): Interpolated grid: dx=1.200 mm, dy=1.200 mm

Maximum value of SAR (interpolated) = 0.198 W/kg

Zoom Scan (7x7x7)/Cube 0: Measurement grid: dx=5mm, dy=5mm, dz=5mm

Reference Value = 9.165 V/m; Power Drift = 0.13 dB

Peak SAR (extrapolated) = 0.276 W/kg

SAR(1 g) = 0.154 W/kg; SAR(10 g) = 0.083 W/kg

Maximum value of SAR (measured) = 0.184 W/kg

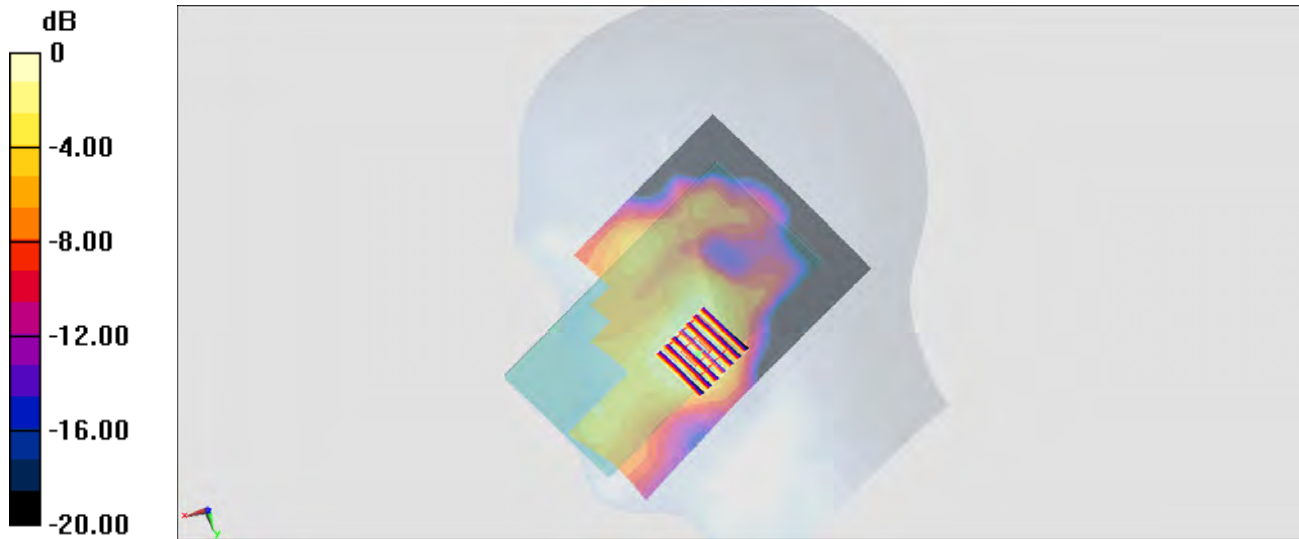

0 dB = 0.184 W/kg = -7.35 dBW/kg

13_WLAN2.4GHz_802.11b 1Mbps_Right Tilted_Ch6

Communication System: 802.11b ; Frequency: 2437 MHz;Duty Cycle: 1:1

Medium: HSL_2450_180612 Medium parameters used : $f = 2437$ MHz; $\sigma = 1.8$ S/m; $\epsilon_r = 40.581$; $\rho = 1000$ kg/m³

Ambient Temperature : 23.3 °C ; Liquid Temperature : 22.3 °C

DASY5 Configuration:

- Probe: EX3DV4 - SN3976; ConvF(7.75, 7.75, 7.75); Calibrated: 2018/1/23
- Sensor-Surface: 1.4mm (Mechanical Surface Detection)
- Electronics: DAE4 Sn778; Calibrated: 2018/5/25
- Phantom: SAM_Left; Type: QD000P40CD; Serial: TP:1815
- Measurement SW: DASY52, Version 52.10 (1);SEMCAD X Version 14.6.11 (7437)

Area Scan (81x61x1): Interpolated grid: dx=1.200 mm, dy=1.200 mm

Maximum value of SAR (interpolated) = 0.589 W/kg

Zoom Scan (7x7x7)/Cube 0: Measurement grid: dx=5mm, dy=5mm, dz=5mm

Reference Value = 9.993 V/m; Power Drift = -0.06 dB

Peak SAR (extrapolated) = 0.833 W/kg

SAR(1 g) = 0.342 W/kg; SAR(10 g) = 0.144 W/kg

Maximum value of SAR (measured) = 0.618 W/kg

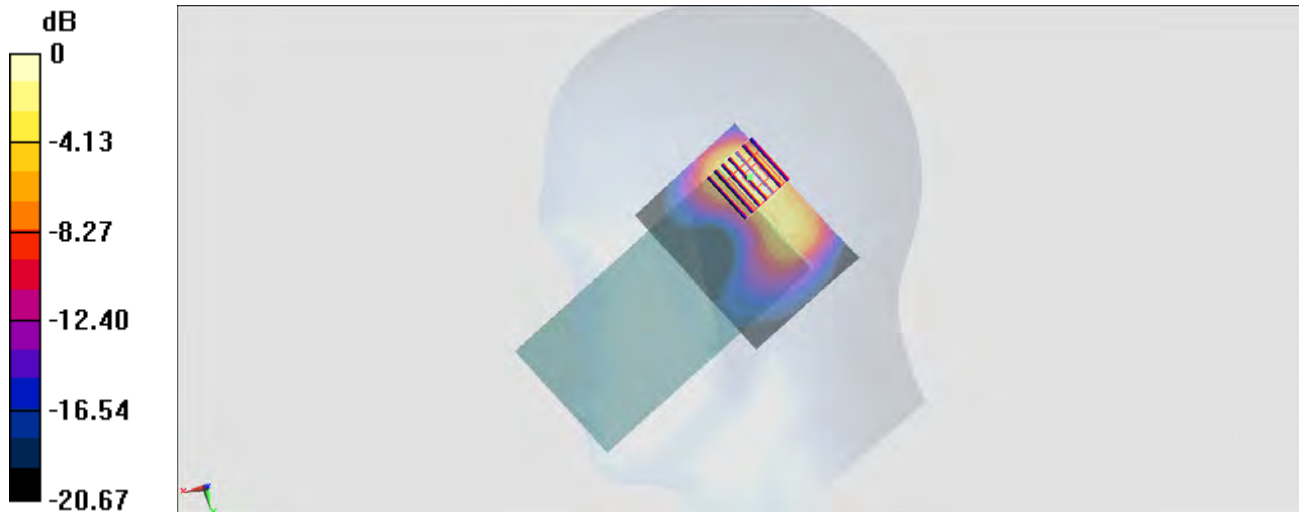

0 dB = 0.618 W/kg = -2.09 dBW/kg

14_WLAN5GHz_802.11n-HT40 MCS0_Right Cheek_Ch62

Communication System: 802.11n ; Frequency: 5310 MHz;Duty Cycle: 1:1.065

Medium: HSL_5G_180610 Medium parameters used: $f = 5310$ MHz; $\sigma = 4.608$ S/m; $\epsilon_r = 36.705$; $\rho = 1000$ kg/m³

Ambient Temperature : 23.5 °C ; Liquid Temperature : 22.5 °C

DASY5 Configuration:

- Probe: EX3DV4 - SN3976; ConvF(5.56, 5.56, 5.56); Calibrated: 2018/1/23
- Sensor-Surface: 1.4mm (Mechanical Surface Detection)
- Electronics: DAE4 Sn778; Calibrated: 2018/5/25
- Phantom: SAM_Left; Type: QD000P40CD; Serial: TP:1815
- Measurement SW: DASY52, Version 52.10 (1);SEMCAD X Version 14.6.11 (7437)

Area Scan (91x71x1): Interpolated grid: dx=1.000 mm, dy=1.000 mm

Maximum value of SAR (interpolated) = 0.501 W/kg

Zoom Scan (7x7x7)/Cube 0: Measurement grid: dx=4mm, dy=4mm, dz=1.4mm

Reference Value = 4.851 V/m; Power Drift = -0.10 dB

Peak SAR (extrapolated) = 0.866 W/kg

SAR(1 g) = 0.206 W/kg; SAR(10 g) = 0.066 W/kg

Maximum value of SAR (measured) = 0.490 W/kg



0 dB = 0.490 W/kg = -3.10 dBW/kg

15_WLAN5GHz_802.11n-HT40 MCS0_Right Cheek_Ch134

Communication System: 802.11n ; Frequency: 5670 MHz;Duty Cycle: 1:1.065

Medium: HSL_5G_180611 Medium parameters used: $f = 5670$ MHz; $\sigma = 5.006$ S/m; $\epsilon_r = 36.362$; $\rho = 1000$ kg/m³

Ambient Temperature : 23.3 °C ; Liquid Temperature : 22.3 °C

DASY5 Configuration:

- Probe: EX3DV4 - SN3976; ConvF(4.97, 4.97, 4.97); Calibrated: 2018/1/23
- Sensor-Surface: 1.4mm (Mechanical Surface Detection)
- Electronics: DAE4 Sn778; Calibrated: 2018/5/25
- Phantom: SAM_Left; Type: QD000P40CD; Serial: TP:1815
- Measurement SW: DASY52, Version 52.10 (1);SEMCAD X Version 14.6.11 (7437)

Area Scan (91x71x1): Interpolated grid: dx=1.000 mm, dy=1.000 mm

Maximum value of SAR (interpolated) = 0.266 W/kg

Zoom Scan (7x7x7)/Cube 0: Measurement grid: dx=4mm, dy=4mm, dz=1.4mm

Reference Value = 3.528 V/m; Power Drift = -0.17 dB

Peak SAR (extrapolated) = 0.368 W/kg

SAR(1 g) = 0.093 W/kg; SAR(10 g) = 0.028 W/kg

Maximum value of SAR (measured) = 0.233 W/kg



0 dB = 0.233 W/kg = -6.33 dBW/kg

16_WLAN5GHz_802.11n-HT40 MCS0_Right Cheek_Ch151

Communication System: 802.11n ; Frequency: 5755 MHz;Duty Cycle: 1:1.065

Medium: HSL_5G_180610 Medium parameters used : $f = 5755$ MHz; $\sigma = 5.07$ S/m; $\epsilon_r = 36.084$; $\rho = 1000$ kg/m³

Ambient Temperature : 23.5 °C ; Liquid Temperature : 22.5 °C

DASY5 Configuration:

- Probe: EX3DV4 - SN3976; ConvF(5.04, 5.04, 5.04); Calibrated: 2018/1/23
- Sensor-Surface: 1.4mm (Mechanical Surface Detection)
- Electronics: DAE4 Sn778; Calibrated: 2018/5/25
- Phantom: SAM_Left; Type: QD000P40CD; Serial: TP:1815
- Measurement SW: DASY52, Version 52.10 (1);SEMCAD X Version 14.6.11 (7437)

Area Scan (91x91x1): Interpolated grid: dx=1.000 mm, dy=1.000 mm

Maximum value of SAR (interpolated) = 0.193 W/kg

Zoom Scan (7x7x7)/Cube 0: Measurement grid: dx=4mm, dy=4mm, dz=1.4mm

Reference Value = 2.630 V/m; Power Drift = -0.15 dB

Peak SAR (extrapolated) = 0.187 W/kg

SAR(1 g) = 0.039 W/kg; SAR(10 g) = 0.011 W/kg

Maximum value of SAR (measured) = 0.112 W/kg



17_GSM850_GPRS (1 Tx slot)_Left Side_10mm_Ch189

Communication System: GSM850; Frequency: 836.4 MHz; Duty Cycle: 1:8.3

Medium: MSL_850_180618 Medium parameters used: $f = 836.4$ MHz; $\sigma = 0.987$ S/m; $\epsilon_r = 55.441$; $\rho = 1000$ kg/m³

Ambient Temperature : 23.4 °C ; Liquid Temperature : 22.4 °C

DASY5 Configuration

- Probe: EX3DV4 - SN3976; ConvF(10.08, 10.08, 10.08) @ 836.4 MHz; Calibrated: 2018/1/23
- Sensor-Surface: 1.4mm (Mechanical Surface Detection)
- Electronics: DAE4 Sn778; Calibrated: 2018/5/25
- Phantom: SAM_Right; Type: QD000P40CD; Serial: S/N:1796
- Measurement SW: DASY52, Version 52.10 (1); SEMCAD X Version 14.6.11 (7439)

Area Scan (41x111x1): Interpolated grid: dx=1.500 mm, dy=1.500 mm

Maximum value of SAR (interpolated) = 0.614 W/kg

Zoom Scan (5x5x7)/Cube 0: Measurement grid: dx=8mm, dy=8mm, dz=5mm

Reference Value = 26.21 V/m; Power Drift = -0.02 dB

Peak SAR (extrapolated) = 0.707 W/kg

SAR(1 g) = 0.483 W/kg; SAR(10 g) = 0.334 W/kg

Maximum value of SAR (measured) = 0.624 W/kg

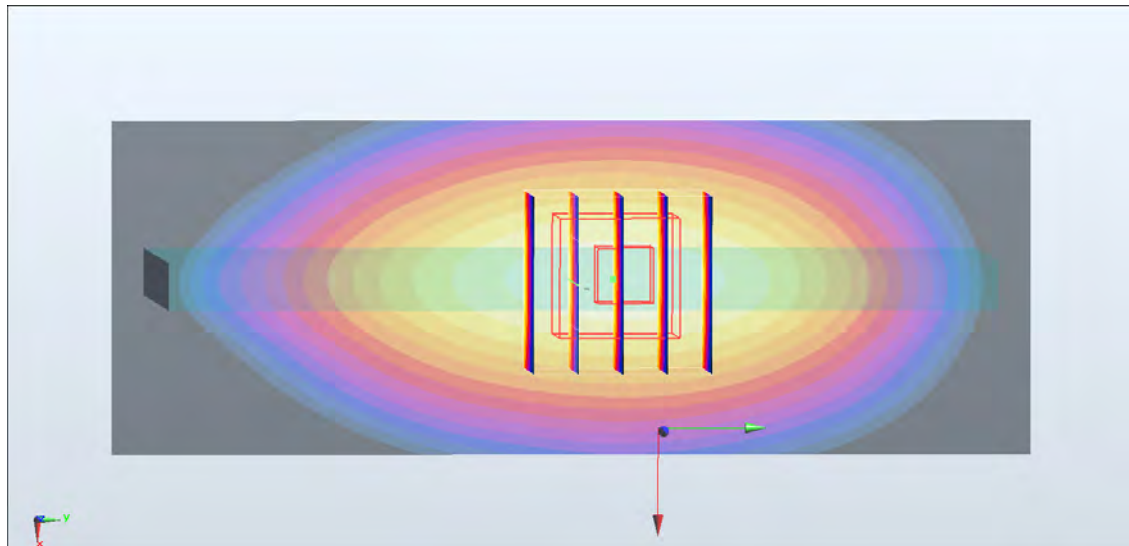
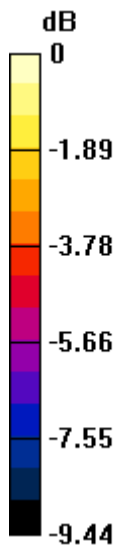

0 dB = 0.624 W/kg = -2.05 dBW/kg

18_GSM1900_GPRS (3 Tx slots)_Bottom Side_10mm_Ch810

Communication System: PCS; Frequency: 1909.8 MHz; Duty Cycle: 1:2.77

Medium: MSL_1900_180615 Medium parameters used: $f = 1910$ MHz; $\sigma = 1.557$ S/m; $\epsilon_r = 53.515$; $\rho = 1000$ kg/m³

Ambient Temperature : 23.2 °C ; Liquid Temperature : 22.2 °C

DASY5 Configuration:

- Probe: ES3DV3 - SN3169; ConvF(4.8, 4.8, 4.8) @ 1909.8 MHz; Calibrated: 2018/5/28
- Sensor-Surface: 3mm (Mechanical Surface Detection)
- Electronics: DAE4 Sn1424; Calibrated: 2018/1/18
- Phantom: SAM_Right; Type: SAM; Serial: TP:1479
- Measurement SW: DASY52, Version 52.10 (1); SEMCAD X Version 14.6.11 (7439)

Area Scan (41x71x1): Interpolated grid: dx=1.500 mm, dy=1.500 mm

Maximum value of SAR (interpolated) = 1.16 W/kg

Zoom Scan (5x5x7)/Cube 0: Measurement grid: dx=8mm, dy=8mm, dz=5mm

Reference Value = 24.90 V/m; Power Drift = -0.01 dB

Peak SAR (extrapolated) = 1.51 W/kg

SAR(1 g) = 0.850 W/kg; SAR(10 g) = 0.435 W/kg

Maximum value of SAR (measured) = 1.03 W/kg

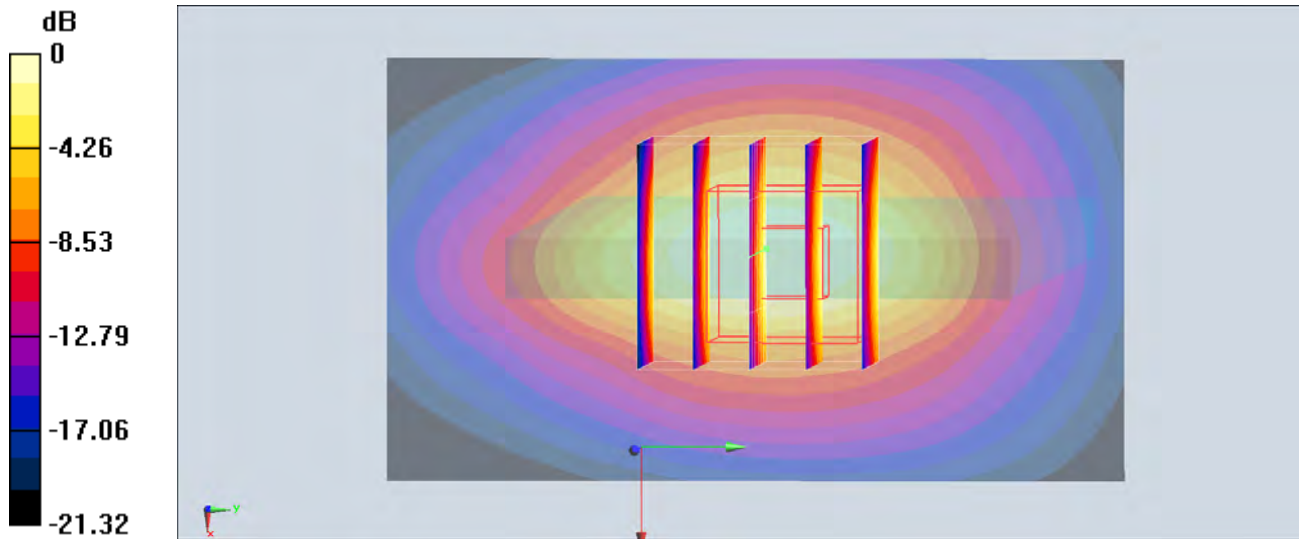

0 dB = 1.03 W/kg = 0.13 dBW/kg

19_WCDMA II_RMC12.2Kbps_Bottom Side_10mm_Ch9262

Communication System: UMTS ; Frequency: 1852.4 MHz;Duty Cycle: 1:1
Medium: MSL_1900 Medium parameters used: $f = 1852.4$ MHz; $\sigma = 1.482$ S/m; $\epsilon_r = 53.653$; $\rho = 1000$ kg/m³
Ambient Temperature : 23.2 °C; Liquid Temperature : 22.8 °C

DASY5 Configuration:

- Probe: EX3DV4 - SN3954; ConvF(8.03, 8.03, 8.03); Calibrated: 2018.1.31;
- Sensor-Surface: 1.4mm (Mechanical Surface Detection)
- Electronics: DAE4 Sn1338; Calibrated: 2017.12.4
- Phantom: SAM1; Type: SAM; Serial: TP-1842
- Measurement SW: DASY52, Version 52.8 (8); SEMCAD X Version 14.6.10 (7331)

Area Scan (31x71x1): Interpolated grid: dx=1.500 mm, dy=1.500 mm
Maximum value of SAR (interpolated) = 1.56 W/kg

Zoom Scan (5x5x7)/Cube 0: Measurement grid: dx=8mm, dy=8mm, dz=5mm
Reference Value = 28.16 V/m; Power Drift = 0.16 dB
Peak SAR (extrapolated) = 1.84 W/kg
SAR(1 g) = 1.19 W/kg; SAR(10 g) = 0.664 W/kg
Maximum value of SAR (measured) = 1.55 W/kg

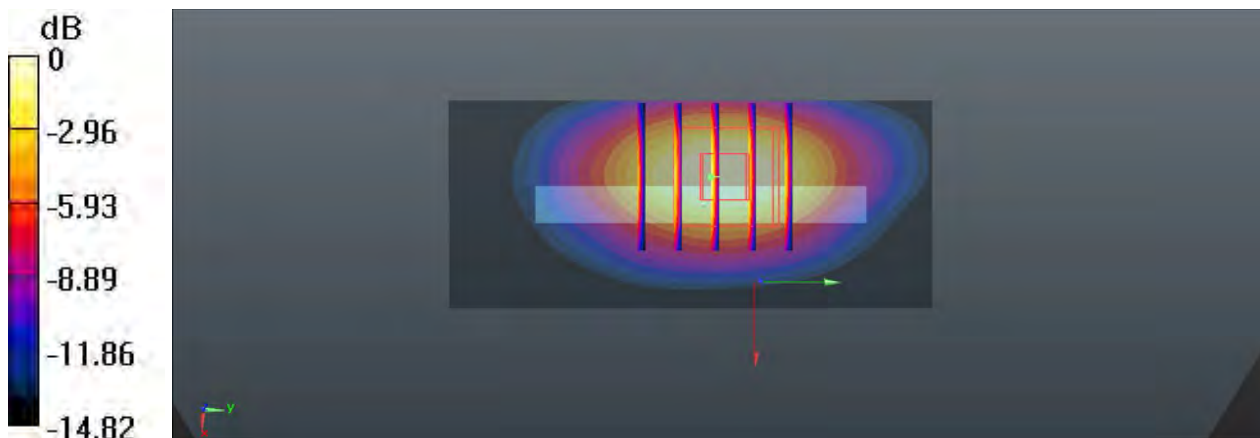

0 dB = 1.55 W/kg = 1.90 dBW/kg

20_WCDMA IV_RMC12.2Kbps_Bottom Side_10mm_Ch1513

Communication System: UMTS ; Frequency: 1752.6 MHz;Duty Cycle: 1:1

Medium: MSL_1750 Medium parameters used: $f = 1753$ MHz; $\sigma = 1.493$ S/m; $\epsilon_r = 54.732$; $\rho = 1000$ kg/m³

Ambient Temperature : 23.3 °C ; Liquid Temperature : 22.6 °C

DASY5 Configuration:

- Probe: EX3DV4 - SN3954; ConvF(8.65, 8.65, 8.65); Calibrated: 2018.1.31;
- Sensor-Surface: 1.4mm (Mechanical Surface Detection)
- Electronics: DAE4 Sn1338; Calibrated: 2017.12.4
- Phantom: SAM3; Type: SAM; Serial: TP-1839
- Measurement SW: DASY52, Version 52.8 (8); SEMCAD X Version 14.6.10 (7331)

Area Scan (41x71x1): Interpolated grid: dx=1.500 mm, dy=1.500 mm

Maximum value of SAR (interpolated) = 1.92 W/kg

Zoom Scan (5x5x7)/Cube 0: Measurement grid: dx=8mm, dy=8mm, dz=5mm

Reference Value = 33.83 V/m; Power Drift = 0.02 dB

Peak SAR (extrapolated) = 2.25 W/kg

SAR(1 g) = 1.34 W/kg; SAR(10 g) = 0.718 W/kg

Maximum value of SAR (measured) = 1.85 W/kg

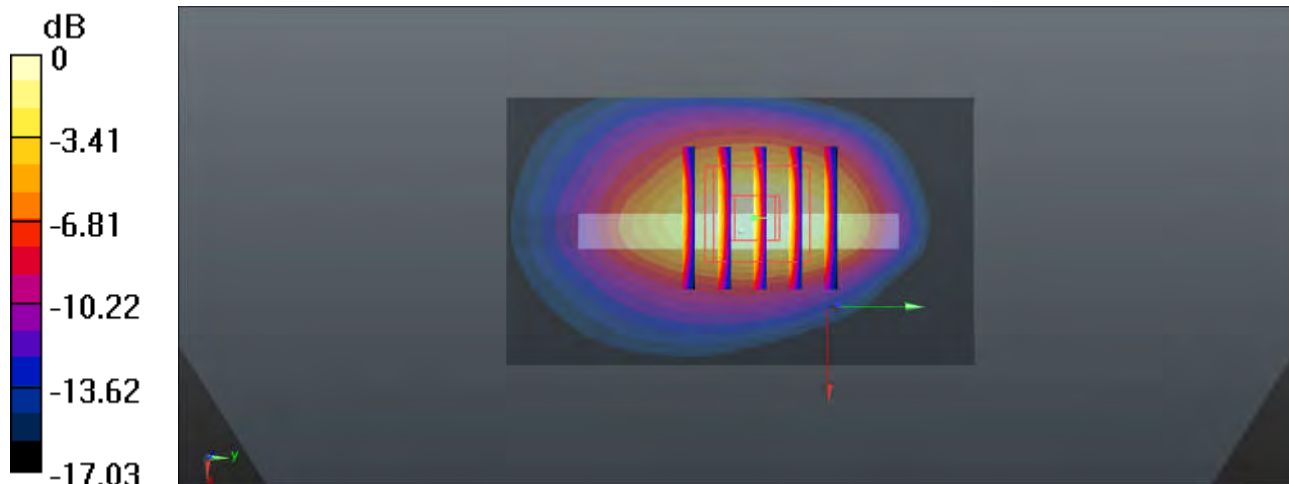

0 dB = 1.85 W/kg = 2.67 dBW/kg

21_WCDMA V_RMC12.2Kbps_Left Side_10mm_Ch4132

Communication System: UMTS ; Frequency: 826.4 MHz; Duty Cycle: 1:1

Medium: MSL_835 Medium parameters used: $f = 826.4 \text{ MHz}$; $\sigma = 0.975 \text{ S/m}$; $\epsilon_r = 56.577$; $\rho = 1000$

kg/m^3

Ambient Temperature : $23.4 \text{ }^\circ\text{C}$; Liquid Temperature : $22.7 \text{ }^\circ\text{C}$

DASY5 Configuration:

- Probe: ES3DV3 - SN3293; ConvF(6.19, 6.19, 6.19); Calibrated: 2017.9.25;
- Sensor-Surface: 3mm (Mechanical Surface Detection)
- Electronics: DAE4 Sn1279; Calibrated: 2018.1.3
- Phantom: SAM2; Type: SAM ; Serial: TP-1503
- Measurement SW: DASY52, Version 52.8 (8); SEMCAD X Version 14.6.10 (7372)

Area Scan (31x121x1): Interpolated grid: $dx=1.500 \text{ mm}$, $dy=1.500 \text{ mm}$

Maximum value of SAR (interpolated) = 0.623 W/kg

Zoom Scan (5x5x7)/Cube 0: Measurement grid: $dx=8\text{mm}$, $dy=8\text{mm}$, $dz=5\text{mm}$

Reference Value = 26.56 V/m ; Power Drift = 0.02 dB

Peak SAR (extrapolated) = 0.782 W/kg

SAR(1 g) = 0.494 W/kg ; SAR(10 g) = 0.333 W/kg

Maximum value of SAR (measured) = 0.631 W/kg

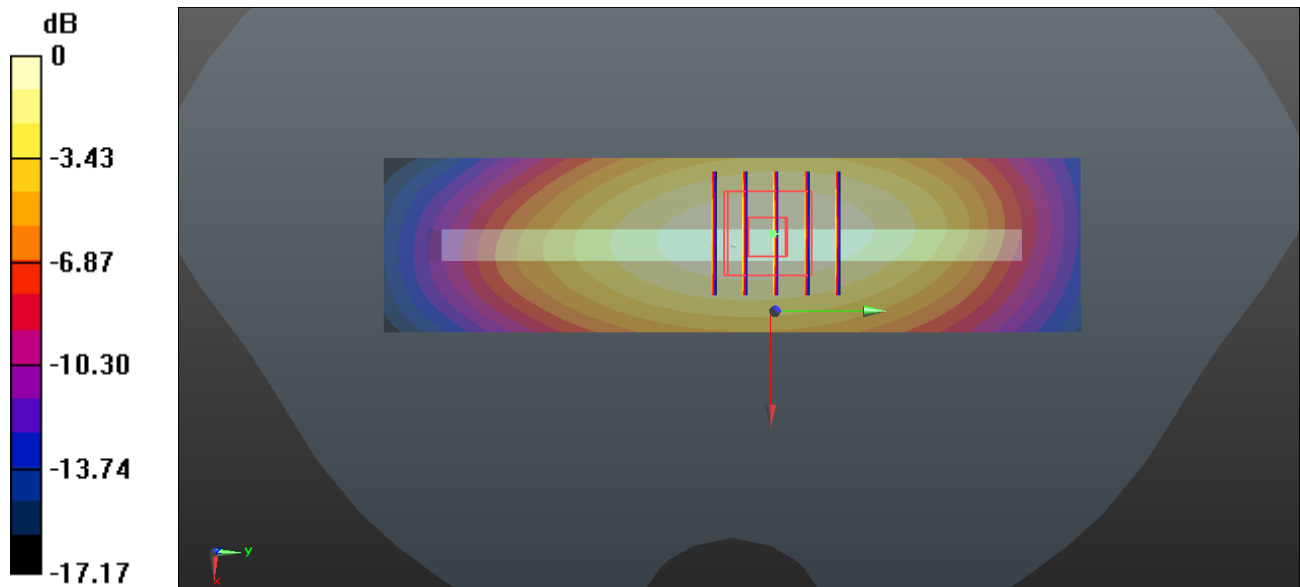

0 dB = $0.623 \text{ W/kg} = -2.06 \text{ dBW/kg}$

22_LTE Band 2_20M_QPSK_50RB_0Offset_Bottom Side_10mm_Ch18700

Communication System: LTE ; Frequency: 1860 MHz;Duty Cycle: 1:1

Medium: MSL_1900 Medium parameters used: $f = 1860$ MHz; $\sigma = 1.492$ S/m; $\epsilon_r = 53.636$; $\rho = 1000$ kg/m³

Ambient Temperature : 23.2 °C ; Liquid Temperature : 22.8 °C

DASY5 Configuration:

- Probe: EX3DV4 - SN3954; ConvF(8.03, 8.03, 8.03); Calibrated: 2018.1.31;
- Sensor-Surface: 1.4mm (Mechanical Surface Detection)
- Electronics: DAE4 Sn1338; Calibrated: 2017.12.4
- Phantom: SAM1; Type: SAM; Serial: TP-1842
- Measurement SW: DASY52, Version 52.8 (8); SEMCAD X Version 14.6.10 (7331)

Area Scan (31x71x1): Interpolated grid: dx=1.500 mm, dy=1.500 mmMaximum value of SAR (interpolated) = 1.68 W/kg

Zoom Scan (5x5x7)/Cube 0: Measurement grid: dx=8mm, dy=8mm, dz=5mm

Reference Value = 30.70 V/m; Power Drift = 0.01 dB

Peak SAR (extrapolated) = 1.94 W/kg

SAR(1 g) = 1.26 W/kg; SAR(10 g) = 0.706 W/kg

Maximum value of SAR (measured) = 1.67 W/kg

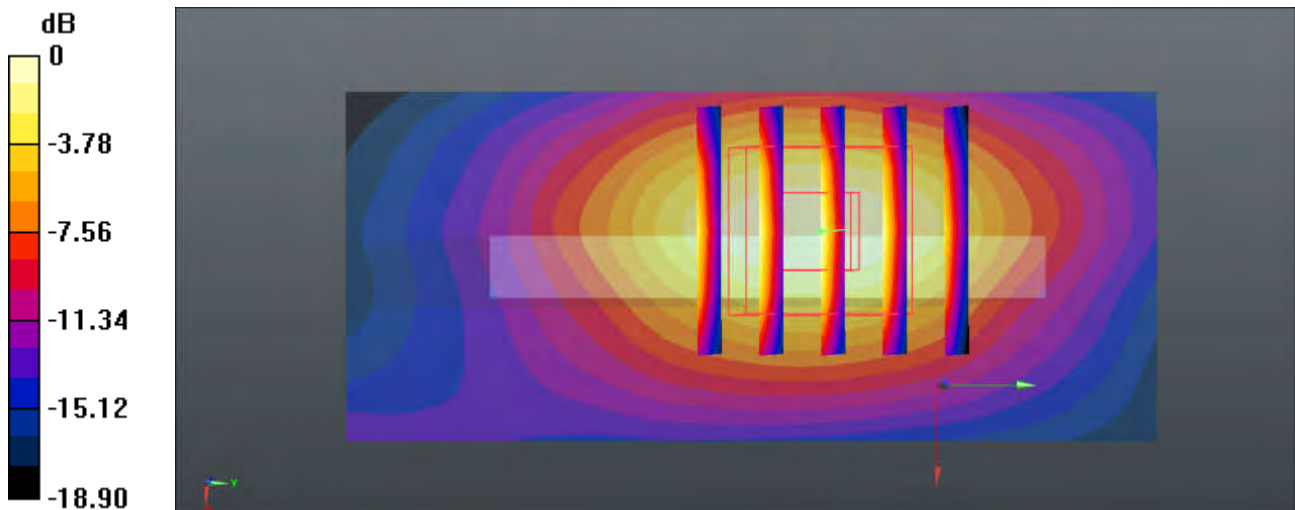

0 dB = 1.68 W/kg = 2.25 dBW/kg

23_LTE Band 5_10M_QPSK_1RB_25Offset_Left Side_10mm_Ch20525

Communication System: LTE ; Frequency: 836.5 MHz;Duty Cycle: 1:1

Medium: MSL_835 Medium parameters used: $f = 836.5 \text{ MHz}$; $\sigma = 0.986 \text{ S/m}$; $\epsilon_r = 56.499$; $\rho = 1000$

kg/m^3

Ambient Temperature : $23.4 \text{ }^\circ\text{C}$; Liquid Temperature : $22.7 \text{ }^\circ\text{C}$

DASY5 Configuration:

- Probe: ES3DV3 - SN3293; ConvF(6.19, 6.19, 6.19); Calibrated: 2017.9.25;
- Sensor-Surface: 3mm (Mechanical Surface Detection)
- Electronics: DAE4 Sn1279; Calibrated: 2018.1.3
- Phantom: SAM2; Type: SAM; Serial: TP-1503
- Measurement SW: DASY52, Version 52.8 (8); SEMCAD X Version 14.6.10 (7372)

Area Scan (41x121x1): Interpolated grid: $dx=1.500 \text{ mm}$, $dy=1.500 \text{ mm}$

Maximum value of SAR (interpolated) = 0.440 W/kg

Zoom Scan (5x5x7)/Cube 0: Measurement grid: $dx=8\text{mm}$, $dy=8\text{mm}$, $dz=5\text{mm}$

Reference Value = 21.54 V/m ; Power Drift = -0.01 dB

Peak SAR (extrapolated) = 0.557 W/kg

SAR(1 g) = 0.348 W/kg ; SAR(10 g) = 0.234 W/kg

Maximum value of SAR (measured) = 0.447 W/kg

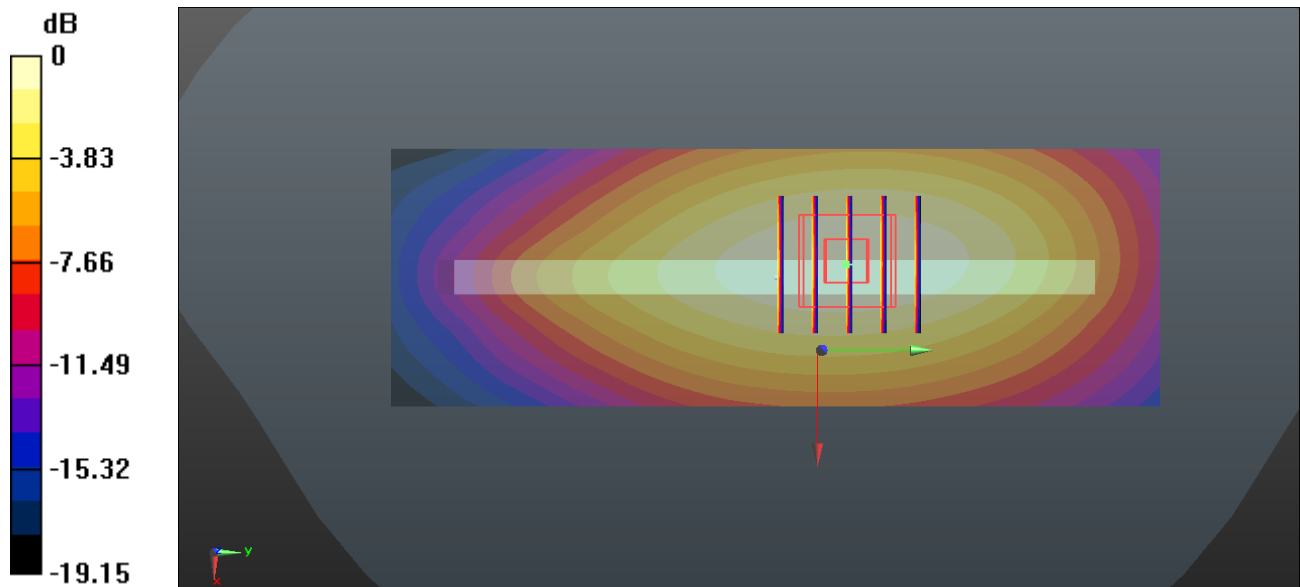

0 dB = $0.440 \text{ W/kg} = -3.57 \text{ dBW/kg}$

24_LTE Band 7_20M_QPSK_1RB_49Offset_Back_10mm_Ch20850

Communication System: LTE ; Frequency: 2510 MHz;Duty Cycle: 1:1

Medium: MSL_2600 Medium parameters used: $f = 2510$ MHz; $\sigma = 2.105$ S/m; $\epsilon_r = 52.793$; $\rho = 1000$ kg/m³

Ambient Temperature : 23.3 °C ; Liquid Temperature : 22.8 °C

DASY5 Configuration:

- Probe: EX3DV4 - SN3954; ConvF(6.92, 6.92, 6.92); Calibrated: 2018.1.31;
- Sensor-Surface: 1.4mm (Mechanical Surface Detection)
- Electronics: DAE4 Sn1338; Calibrated: 2017.12.4
- Phantom: SAM1; Type: SAM; Serial: TP-1842
- Measurement SW: DASY52, Version 52.8 (8); SEMCAD X Version 14.6.10 (7331)

Area Scan (81x151x1): Interpolated grid: dx=1.200 mm, dy=1.200 mmMaximum value of SAR (interpolated) = 1.35 W/kg

Zoom Scan (7x7x7)/Cube 0: Measurement grid: dx=5mm, dy=5mm, dz=5mm

Reference Value = 9.167 V/m; Power Drift = 0.02 dB

Peak SAR (extrapolated) = 1.75 W/kg

SAR(1 g) = 1.06 W/kg; SAR(10 g) = 0.627 W/kg

Maximum value of SAR (measured) = 1.42 W/kg

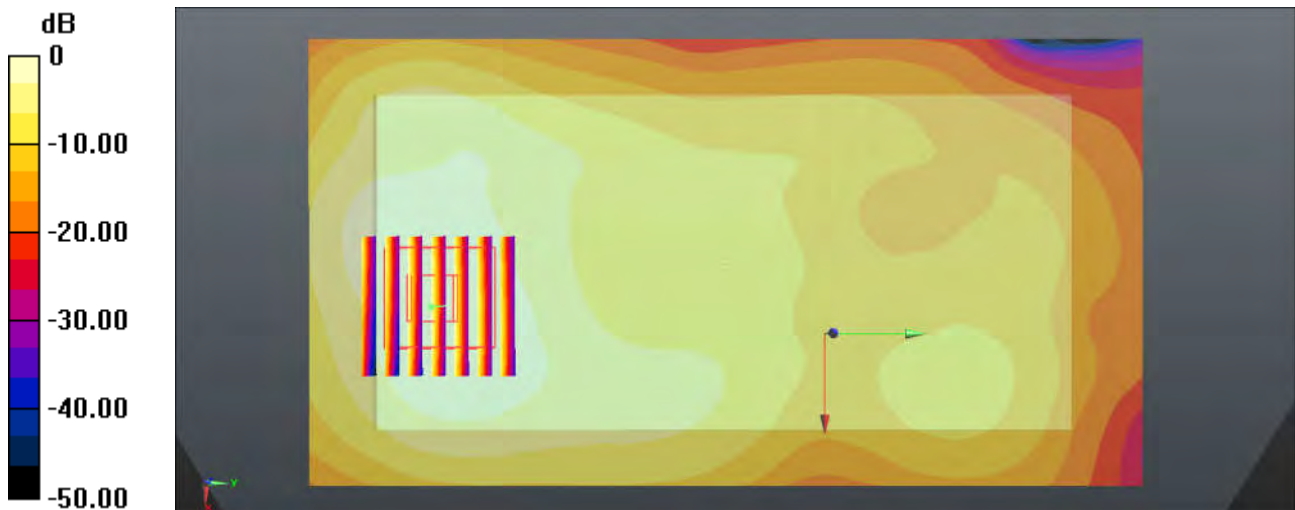

0 dB = 1.35 W/kg = 1.30 dBW/kg

25_LTE Band 12_QPSK_10M_1RB_25Offset_Left Side_10mm_Ch23095

Communication System: LTE ; Frequency: 707.5 MHz;Duty Cycle: 1:1

Medium: MSL_750 Medium parameters used: $f = 707.5$ MHz; $\sigma = 0.923$ S/m; $\epsilon_r = 56.587$; $\rho = 1000$

kg/m³

Ambient Temperature : 23.3 °C ; Liquid Temperature : 22.7 °C

DASY5 Configuration:

- Probe: ES3DV3 - SN3293; ConvF(6.43, 6.43, 6.43); Calibrated: 2017.9.25;
- Sensor-Surface: 3mm (Mechanical Surface Detection)
- Electronics: DAE4 Sn1279; Calibrated: 2018.1.3
- Phantom: SAM2; Type: SAM; Serial: TP-1503
- Measurement SW: DASY52, Version 52.8 (8); SEMCAD X Version 14.6.10 (7372)

Area Scan (31x121x1): Interpolated grid: dx=1.500 mm, dy=1.500 mm

Maximum value of SAR (interpolated) = 0.366 W/kg

Zoom Scan (5x5x7)/Cube 0: Measurement grid: dx=8mm, dy=8mm, dz=5mm

Reference Value = 21.14 V/m; Power Drift = 0.17 dB

Peak SAR (extrapolated) = 0.471 W/kg

SAR(1 g) = 0.305 W/kg; SAR(10 g) = 0.209 W/kg

Maximum value of SAR (measured) = 0.385 W/kg

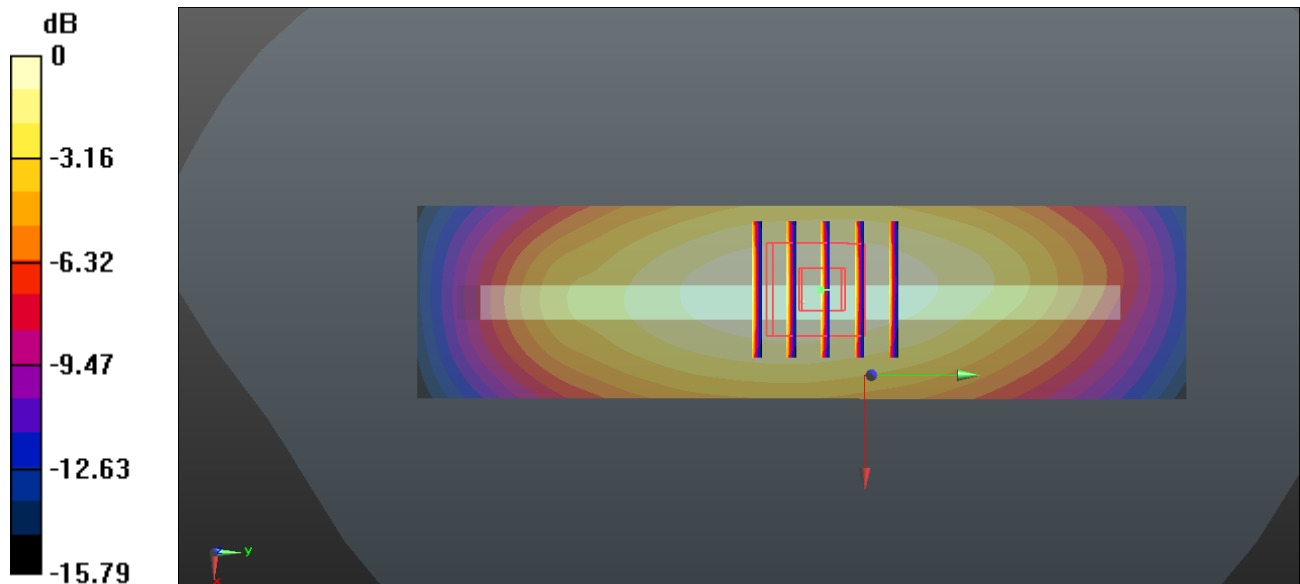

0 dB = 0.366 W/kg = -4.37 dBW/kg

26_LTE Band 13_10M_QPSK_1RB_25Offset_Left Side_10mm_Ch23230

Communication System: LTE ; Frequency: 782 MHz;Duty Cycle: 1:1

Medium: MSL_750 Medium parameters used: $f = 782 \text{ MHz}$; $\sigma = 0.999 \text{ S/m}$; $\epsilon_r = 55.861$; $\rho = 1000$

kg/m^3

Ambient Temperature : $23.3 \text{ }^\circ\text{C}$; Liquid Temperature : $22.7 \text{ }^\circ\text{C}$

DASY5 Configuration:

- Probe: ES3DV3 - SN3293; ConvF(6.43, 6.43, 6.43); Calibrated: 2017.9.25;
- Sensor-Surface: 3mm (Mechanical Surface Detection)
- Electronics: DAE4 Sn1279; Calibrated: 2018.1.3
- Phantom: SAM2; Type: SAM ; Serial: TP-1503
- Measurement SW: DASY52, Version 52.8 (8); SEMCAD X Version 14.6.10 (7372)

Area Scan (41x121x1): Interpolated grid: $dx=1.500 \text{ mm}$, $dy=1.500 \text{ mm}$

Maximum value of SAR (interpolated) = 0.629 W/kg

Zoom Scan (5x5x7)/Cube 0: Measurement grid: $dx=8\text{mm}$, $dy=8\text{mm}$, $dz=5\text{mm}$

Reference Value = 26.19 V/m ; Power Drift = -0.01 dB

Peak SAR (extrapolated) = 0.778 W/kg

SAR(1 g) = 0.498 W/kg ; SAR(10 g) = 0.339 W/kg

Maximum value of SAR (measured) = 0.633 W/kg

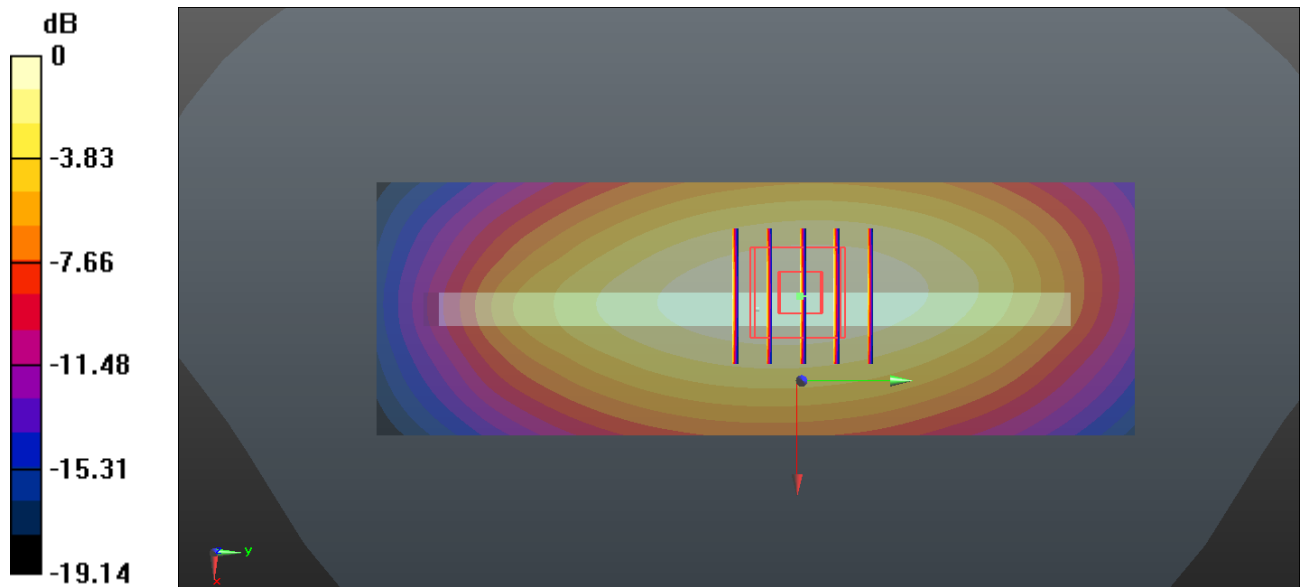

0 dB = 0.629 W/kg = -2.01 dBW/kg

27_LTE Band 66_20M_QPSK_100_0_Bottom Side_10mm_Ch132572

Communication System: LTE; Frequency: 1770 MHz; Duty Cycle: 1:1

Medium: MSL_1750_180619 Medium parameters used: $f = 1770$ MHz; $\sigma = 1.506$ S/m; $\epsilon_r = 54.743$; $\rho = 1000$ kg/m³

Ambient Temperature : 23.1 °C; Liquid Temperature : 22.1 °C

DASY5 Configuration:

- Probe: ES3DV3 - SN3169; ConvF(5.06, 5.06, 5.06) @ 1770 MHz; Calibrated: 2018/5/28
- Sensor-Surface: 3mm (Mechanical Surface Detection)
- Electronics: DAE4 Sn1424; Calibrated: 2018/1/18
- Phantom: SAM_Left; Type: QD000P40CD; Serial: TP:1477
- Measurement SW: DASY52, Version 52.10 (1); SEMCAD X Version 14.6.11 (7439)

Area Scan (41x71x1): Interpolated grid: dx=1.500 mm, dy=1.500 mm

Maximum value of SAR (interpolated) = 1.90 W/kg

Zoom Scan (5x5x7)/Cube 0: Measurement grid: dx=8mm, dy=8mm, dz=5mm

Reference Value = 29.04 V/m; Power Drift = 0.18 dB

Peak SAR (extrapolated) = 2.55 W/kg

SAR(1 g) = 1.47 W/kg; SAR(10 g) = 0.777 W/kg

Maximum value of SAR (measured) = 1.80 W/kg

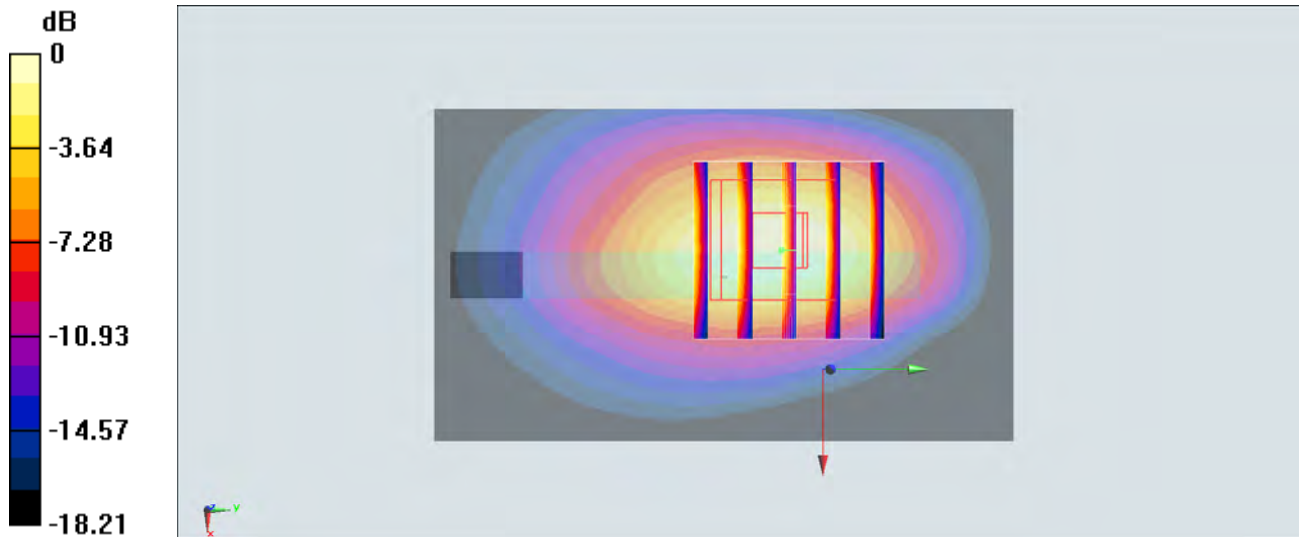

0 dB = 1.80 W/kg = 2.55 dBW/kg

28_LTE Band 38_20M_QPSK_1_49_Back_10mm_Ch38150

Communication System: LTE; Frequency: 2610 MHz; Duty Cycle: 1:1.59

Medium: MSL_2600_180619 Medium parameters used : $f = 2610$ MHz; $\sigma = 2.203$ S/m; $\epsilon_r = 50.628$; $\rho = 1000$ kg/m³

Ambient Temperature : 23.5 °C ; Liquid Temperature : 22.5 °C

DASY5 Configuration:

- Probe: EX3DV4 - SN3925; ConvF(7.59, 7.59, 7.59); Calibrated: 2018/5/31
- Sensor-Surface: 1.4mm (Mechanical Surface Detection)
- Electronics: DAE3 Sn495; Calibrated: 2018/5/24
- Phantom: SAM_Right; Type: QD000P40CD; Serial: 1884
- Measurement SW: DASY52, Version 52.10 (1); SEMCAD X Version 14.6.11 (7437)

Area Scan (91x61x1): Interpolated grid: dx=1.200 mm, dy=1.200 mm

Maximum value of SAR (interpolated) = 0.618 W/kg

Zoom Scan (7x7x7)/Cube 0: Measurement grid: dx=5mm, dy=5mm, dz=5mm

Reference Value = 16.43 V/m; Power Drift = 0.00 dB

Peak SAR (extrapolated) = 0.745 W/kg

SAR(1 g) = 0.392 W/kg; SAR(10 g) = 0.213 W/kg

Maximum value of SAR (measured) = 0.602 W/kg

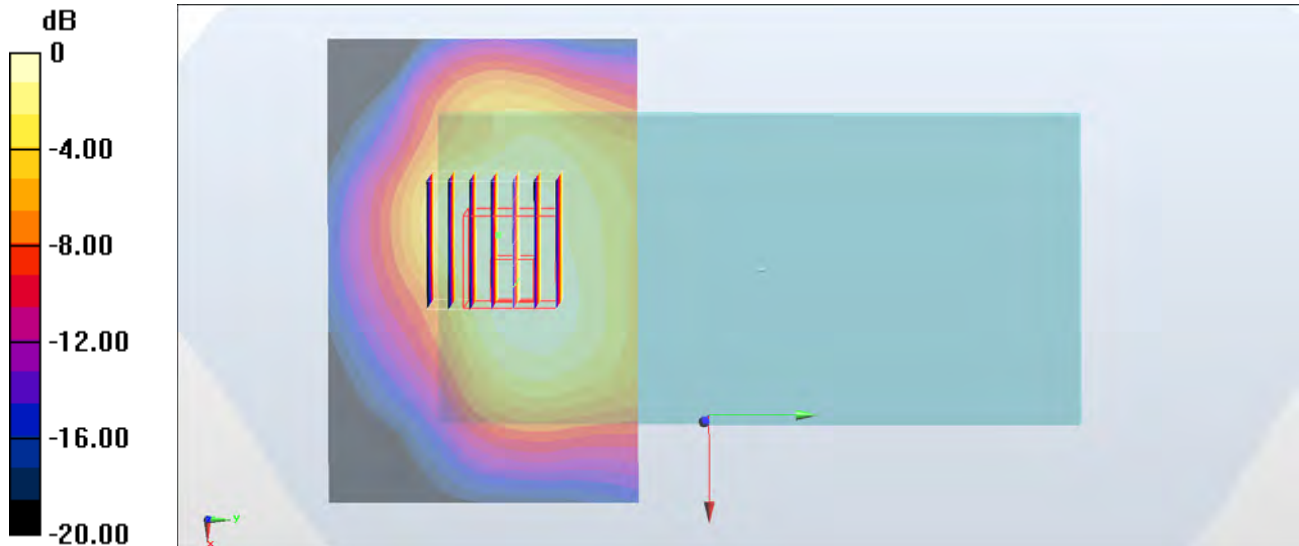

0 dB = 0.602 W/kg = -2.20 dBW/kg

29_WLAN2.4G_802.11b 1Mbps_Top side_10mm_Ch6

Communication System: 802.11b; Frequency: 2437 MHz; Duty Cycle: 1:1

Medium: MSL2450_180620 Medium parameters used : $f = 2437$ MHz; $\sigma = 1.965$ S/m; $\epsilon_r = 52.388$; $\rho = 1000$ kg/m³

Ambient Temperature : 23.5 °C ; Liquid Temperature : 22.5 °C

DASY5 Configuration:

- Probe: ES3DV3 - SN3169; ConvF(4.4, 4.4, 4.4) @ 2437 MHz; Calibrated: 2018/5/28
- Sensor-Surface: 3mm (Mechanical Surface Detection)
- Electronics: DAE4 Sn1424; Calibrated: 2018/1/18
- Phantom: SAM_Right; Type: SAM; Serial: TP:1479
- Measurement SW: DASY52, Version 52.10 (1); SEMCAD X Version 14.6.11 (7439)

Area Scan (61x81x1): Interpolated grid: dx=1.200 mm, dy=1.200 mm

Maximum value of SAR (interpolated) = 0.142 W/kg

Zoom Scan (7x7x7)/Cube 0: Measurement grid: dx=5mm, dy=5mm, dz=5mm

Reference Value = 6.369 V/m; Power Drift = -0.08 dB

Peak SAR (extrapolated) = 0.229 W/kg

SAR(1 g) = 0.118 W/kg; SAR(10 g) = 0.061 W/kg

Maximum value of SAR (measured) = 0.148 W/kg

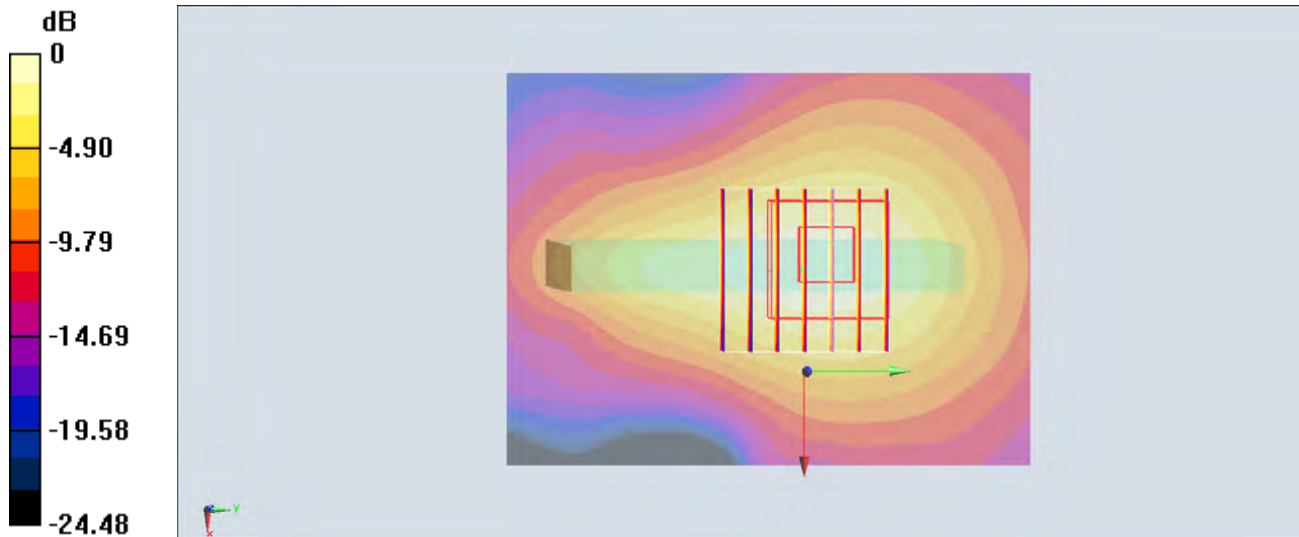

0 dB = 0.148 W/kg = -8.30 dBW/kg

30_WLAN5GHz_802.11n-HT40 MCS0_Top Side_10mm_Ch38

Communication System: 802.11n ; Frequency: 5190 MHz;Duty Cycle: 1:1.065

Medium: MSL_5G_180620 Medium parameters used: $f = 5190$ MHz; $\sigma = 5.417$ S/m; $\epsilon_r = 46.987$; $\rho = 1000$ kg/m³

Ambient Temperature : 23.5 °C ; Liquid Temperature : 22.5 °C

DASY5 Configuration:

- Probe: EX3DV4 - SN3976; ConvF(4.92, 4.92, 4.92) @ 5190 MHz; Calibrated: 2018/1/23
- Sensor-Surface: 1.4mm (Mechanical Surface Detection)
- Electronics: DAE4 Sn778; Calibrated: 2018/5/25
- Phantom: SAM_Right; Type: SAM; Serial: TP:1479
- Measurement SW: DASY52, Version 52.10 (1);SEMCAD X Version 14.6.11 (7439)

Area Scan (61x121x1): Interpolated grid: dx=1.000 mm, dy=1.000 mm

Maximum value of SAR (interpolated) = 0.0246 W/kg

Zoom Scan (7x7x7)/Cube 0: Measurement grid: dx=4mm, dy=4mm, dz=1.4mm

Reference Value = 0.4980 V/m; Power Drift = -0.00 dB

Peak SAR (extrapolated) = 0.145 W/kg

SAR(1 g) = 0.011 W/kg; SAR(10 g) = 0.00308 W/kg

Maximum value of SAR (measured) = 0.0367 W/kg

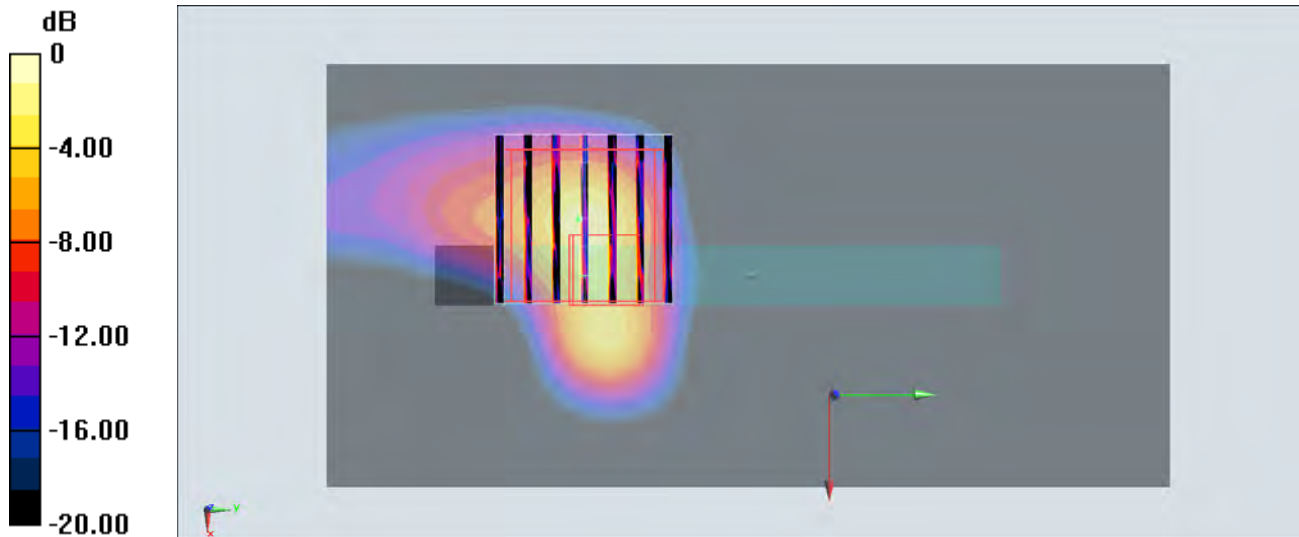

0 dB = 0.0367 W/kg = -14.35 dBW/kg

31_WLAN5GHz_802.11n-HT40 MCS0_Top Side_10mm_Ch151

Communication System: 802.11n ; Frequency: 5755 MHz; Duty Cycle: 1:1.065

Medium: MSL_5G_180620 Medium parameters used : $f = 5755$ MHz; $\sigma = 6.14$ S/m; $\epsilon_r = 45.92$; $\rho = 1000$ kg/m³

Ambient Temperature : 23.5 °C ; Liquid Temperature : 22.5 °C

DASY5 Configuration:

- Probe: EX3DV4 - SN3976; ConvF(4.46, 4.46, 4.46) @ 5755 MHz; Calibrated: 2018/1/23
- Sensor-Surface: 1.4mm (Mechanical Surface Detection)
- Electronics: DAE4 Sn778; Calibrated: 2018/5/25
- Phantom: SAM_Right; Type: SAM; Serial: TP:1479
- Measurement SW: DASY52, Version 52.10 (1); SEMCAD X Version 14.6.11 (7439)

Area Scan (61x121x1): Interpolated grid: dx=1.000 mm, dy=1.000 mm

Maximum value of SAR (interpolated) = 0.0108 W/kg

Zoom Scan (7x7x7)/Cube 0: Measurement grid: dx=4mm, dy=4mm, dz=1.4mm

Reference Value = 0.5630 V/m; Power Drift = 0.19 dB

Peak SAR (extrapolated) = 0.125 W/kg

SAR(1 g) = 0.00584 W/kg; SAR(10 g) = 0.00101 W/kg

Maximum value of SAR (measured) = 0.0228 W/kg

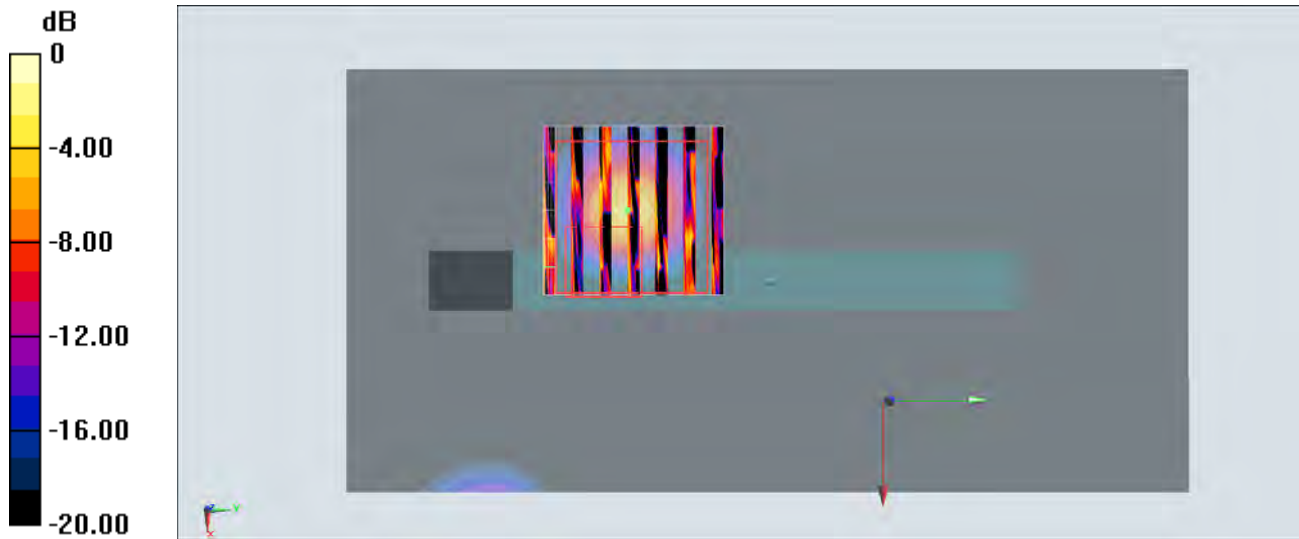

0 dB = 0.0228 W/kg = -16.42 dBW/kg

32_GSM850_GPRS (1 Tx slot)_Back_15mm_Ch189

Communication System: GSM850; Frequency: 836.4 MHz; Duty Cycle: 1:8.3

Medium: MSL_850_180618 Medium parameters used: $f = 836.4$ MHz; $\sigma = 0.987$ S/m; $\epsilon_r = 55.441$; $\rho = 1000$ kg/m³

Ambient Temperature : 23.4 °C ; Liquid Temperature : 22.4 °C

DASY5 Configuration

- Probe: EX3DV4 - SN3976; ConvF(10.08, 10.08, 10.08) @ 836.4 MHz; Calibrated: 2018/1/23
- Sensor-Surface: 1.4mm (Mechanical Surface Detection)
- Electronics: DAE4 Sn778; Calibrated: 2018/5/25
- Phantom: SAM_Right; Type: QD000P40CD; Serial: S/N:1796
- Measurement SW: DASY52, Version 52.10 (1); SEMCAD X Version 14.6.11 (7439)

Area Scan (71x121x1): Interpolated grid: dx=1.500 mm, dy=1.500 mm

Maximum value of SAR (interpolated) = 0.475 W/kg

Zoom Scan (5x5x7)/Cube 0: Measurement grid: dx=8mm, dy=8mm, dz=5mm

Reference Value = 22.85 V/m; Power Drift = -0.04 dB

Peak SAR (extrapolated) = 0.521 W/kg

SAR(1 g) = 0.406 W/kg; SAR(10 g) = 0.316 W/kg

Maximum value of SAR (measured) = 0.481 W/kg

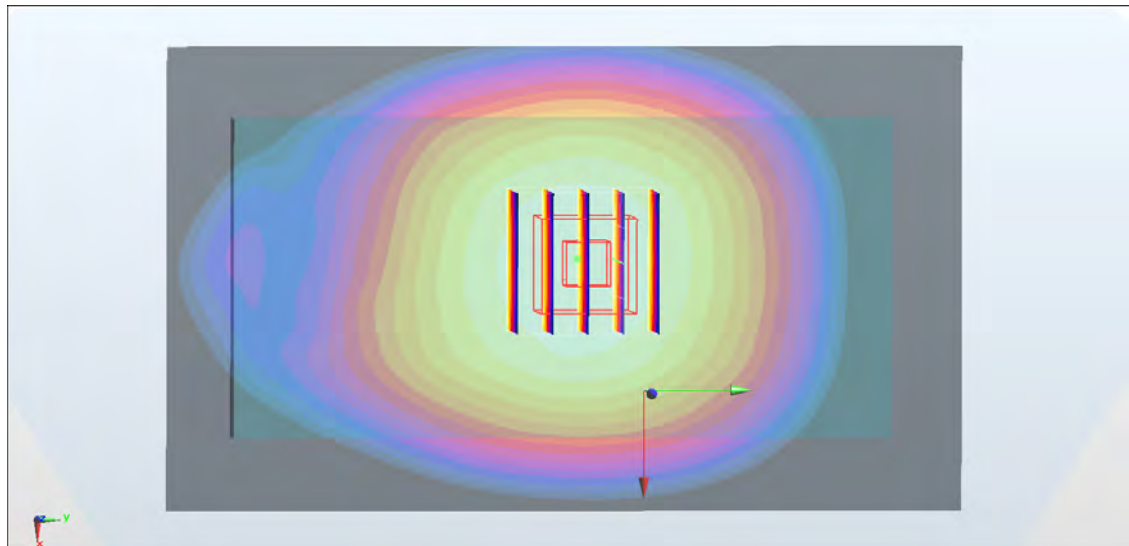
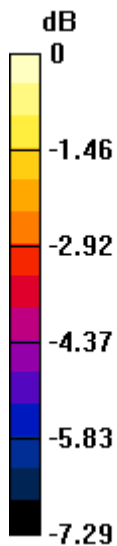

0 dB = 0.481 W/kg = -3.18 dBW/kg

33_GSM1900_GPRS (1 Tx slot)_Back_15mm_Ch512

Communication System: PCS; Frequency: 1850.2 MHz; Duty Cycle: 1:8.3

Medium: MSL_1900_180615 Medium parameters used : $f = 1850.2$ MHz; $\sigma = 1.495$ S/m; $\epsilon_r = 53.682$; $\rho = 1000$ kg/m³

Ambient Temperature : 23.2 °C ; Liquid Temperature : 22.2 °C

DASY5 Configuration:

- Probe: ES3DV3 - SN3169; ConvF(4.8, 4.8, 4.8) @ 1850.2 MHz; Calibrated: 2018/5/28
- Sensor-Surface: 3mm (Mechanical Surface Detection)
- Electronics: DAE4 Sn1424; Calibrated: 2018/1/18
- Phantom: SAM_Right; Type: SAM; Serial: TP:1479
- Measurement SW: DASY52, Version 52.10 (1); SEMCAD X Version 14.6.11 (7439)

Area Scan (71x61x1): Interpolated grid: dx=1.500 mm, dy=1.500 mm

Maximum value of SAR (interpolated) = 0.628 W/kg

Zoom Scan (5x5x7)/Cube 0: Measurement grid: dx=8mm, dy=8mm, dz=5mm

Reference Value = 15.18 V/m; Power Drift = 0.07 dB

Peak SAR (extrapolated) = 0.822 W/kg

SAR(1 g) = 0.514 W/kg; SAR(10 g) = 0.293 W/kg

Maximum value of SAR (measured) = 0.592 W/kg

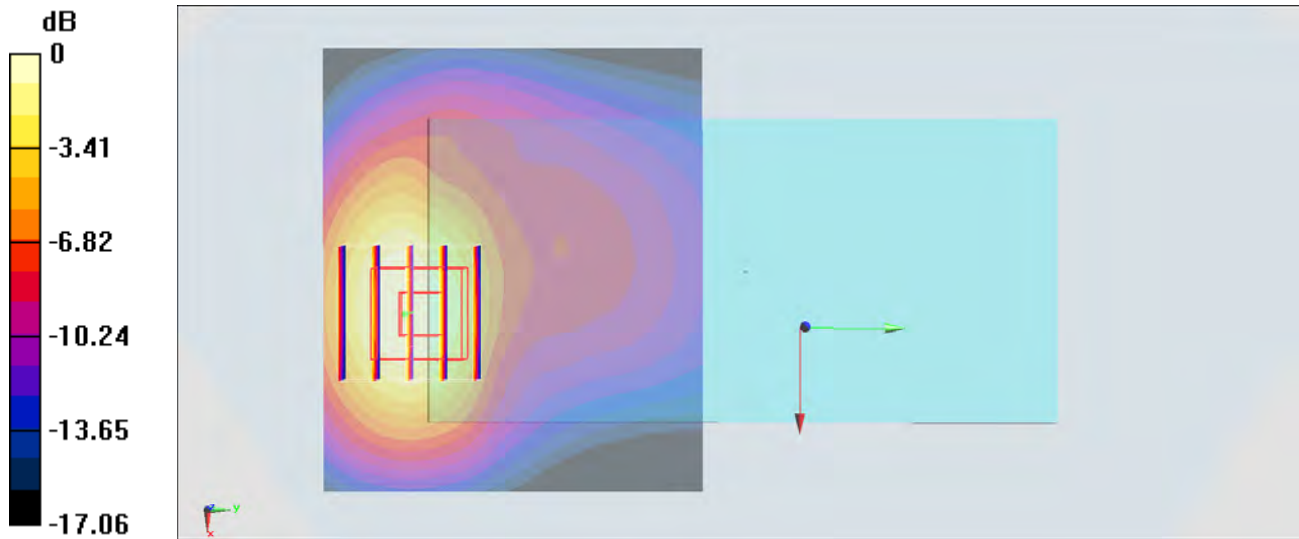

0 dB = 0.592 W/kg = -2.28 dBW/kg

34_WCDMA II_RMC12.2Kbps_Back_15mm_Ch9262

Communication System: UMTS ; Frequency: 1852.4 MHz; Duty Cycle: 1:1

Medium: MSL_1900 Medium parameters used: $f = 1852.4$ MHz; $\sigma = 1.482$ S/m; $\epsilon_r = 53.653$; $\rho = 1000$ kg/m³

Ambient Temperature : 23.2 °C ; Liquid Temperature : 22.8 °C

DASY5 Configuration:

- Probe: EX3DV4 - SN3954; ConvF(8.03, 8.03, 8.03); Calibrated: 2018.1.31;
- Sensor-Surface: 1.4mm (Mechanical Surface Detection)
- Electronics: DAE4 Sn1338; Calibrated: 2017.12.4
- Phantom: SAM1; Type: SAM; Serial: TP-1842
- Measurement SW: DASY52, Version 52.8 (8); SEMCAD X Version 14.6.10 (7331)

Area Scan (61x121x1): Interpolated grid: dx=1.500 mm, dy=1.500 mm

Maximum value of SAR (interpolated) = 1.44 W/kg

Zoom Scan (5x5x7)/Cube 0: Measurement grid: dx=8mm, dy=8mm, dz=5mm

Reference Value = 6.511 V/m; Power Drift = -0.10 dB

Peak SAR (extrapolated) = 1.61 W/kg

SAR(1 g) = 1.07 W/kg; SAR(10 g) = 0.638 W/kg

Maximum value of SAR (measured) = 1.36 W/kg

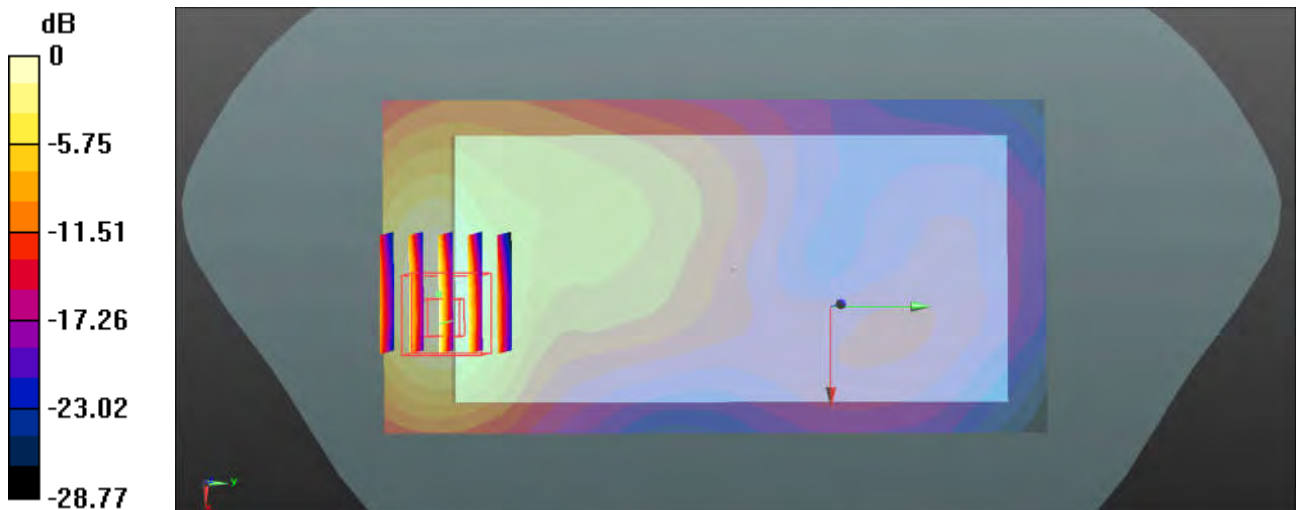

0 dB = 1.44 W/kg = 1.58 dBW/kg

35_WCDMA IV_RMC12.2Kbps_Back_15mm_Ch1513

Communication System: UMTS ; Frequency: 1752.6 MHz; Duty Cycle: 1:1

Medium: MSL_1750 Medium parameters used: $f = 1753$ MHz; $\sigma = 1.493$ S/m; $\epsilon_r = 54.732$; $\rho = 1000$ kg/m³

Ambient Temperature : 23.3 °C ; Liquid Temperature : 22.6 °C

DASY5 Configuration:

- Probe: EX3DV4 - SN3954; ConvF(8.31, 8.31, 8.31); Calibrated: 2018.1.31;
- Sensor-Surface: 1.4mm (Mechanical Surface Detection)
- Electronics: DAE4 Sn1338; Calibrated: 2017.12.4
- Phantom: SAM3; Type: SAM; Serial: TP-1839
- Measurement SW: DASY52, Version 52.8 (8); SEMCAD X Version 14.6.10 (7331)

Area Scan (61x121x1): Interpolated grid: dx=1.500 mm, dy=1.500 mm

Maximum value of SAR (interpolated) = 0.966 W/kg

Zoom Scan (5x5x7)/Cube 0: Measurement grid: dx=8mm, dy=8mm, dz=5mm

Reference Value = 3.724 V/m; Power Drift = 0.06 dB

Peak SAR (extrapolated) = 1.13 W/kg

SAR(1 g) = 0.752 W/kg; SAR(10 g) = 0.450 W/kg

Maximum value of SAR (measured) = 0.963 W/kg

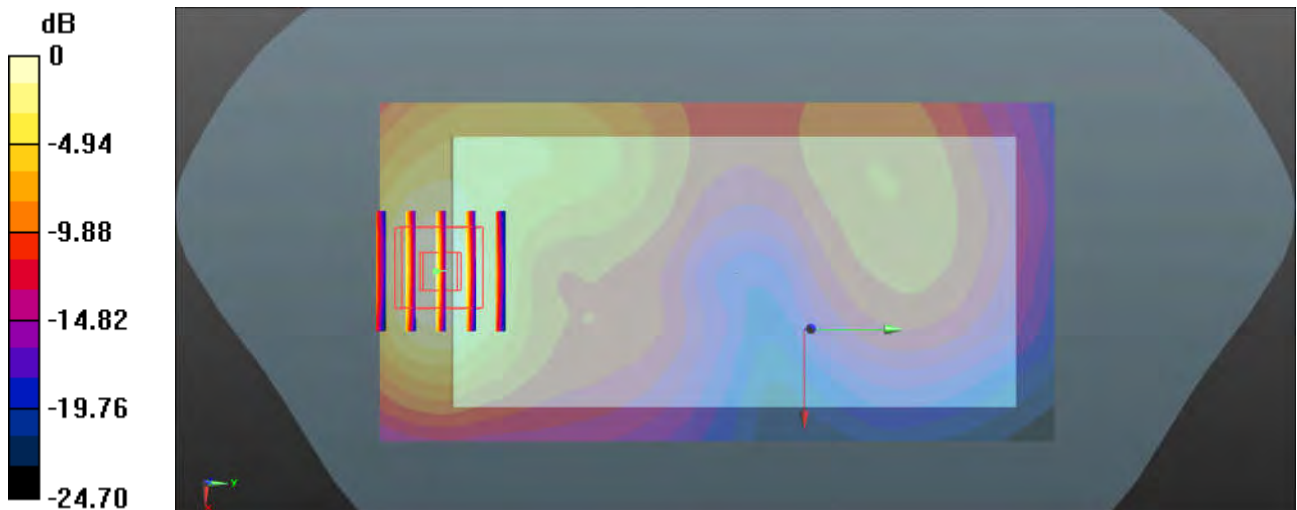

0 dB = 0.966 W/kg = -0.15 dBW/kg

36_WCDMA V_RMC12.2Kbps_Back_15mm_Ch4132

Communication System: UMTS ; Frequency: 826.4 MHz; Duty Cycle: 1:1

Medium: MSL_835 Medium parameters used: $f = 826.4 \text{ MHz}$; $\sigma = 0.975 \text{ S/m}$; $\epsilon_r = 56.577$; $\rho = 1000$

kg/m^3

Ambient Temperature : $23.4 \text{ }^\circ\text{C}$; Liquid Temperature : $22.7 \text{ }^\circ\text{C}$

DASY5 Configuration:

- Probe: ES3DV3 - SN3293; ConvF(6.19, 6.19, 6.19); Calibrated: 2017.9.25;
- Sensor-Surface: 3mm (Mechanical Surface Detection)
- Electronics: DAE4 Sn1279; Calibrated: 2018.1.3
- Phantom: SAM2; Type: SAM ; Serial: TP-1503
- Measurement SW: DASY52, Version 52.8 (8); SEMCAD X Version 14.6.10 (7331)

Area Scan (71x121x1): Interpolated grid: $dx=1.500 \text{ mm}$, $dy=1.500 \text{ mm}$

Maximum value of SAR (interpolated) = 0.491 W/kg

Zoom Scan (5x5x7)/Cube 0: Measurement grid: $dx=8\text{mm}$, $dy=8\text{mm}$, $dz=5\text{mm}$

Reference Value = 11.67 V/m ; Power Drift = 0.01 dB

Peak SAR (extrapolated) = 0.138 W/kg

SAR(1 g) = 0.099 W/kg ; SAR(10 g) = 0.074 W/kg

Maximum value of SAR (measured) = 0.117 W/kg

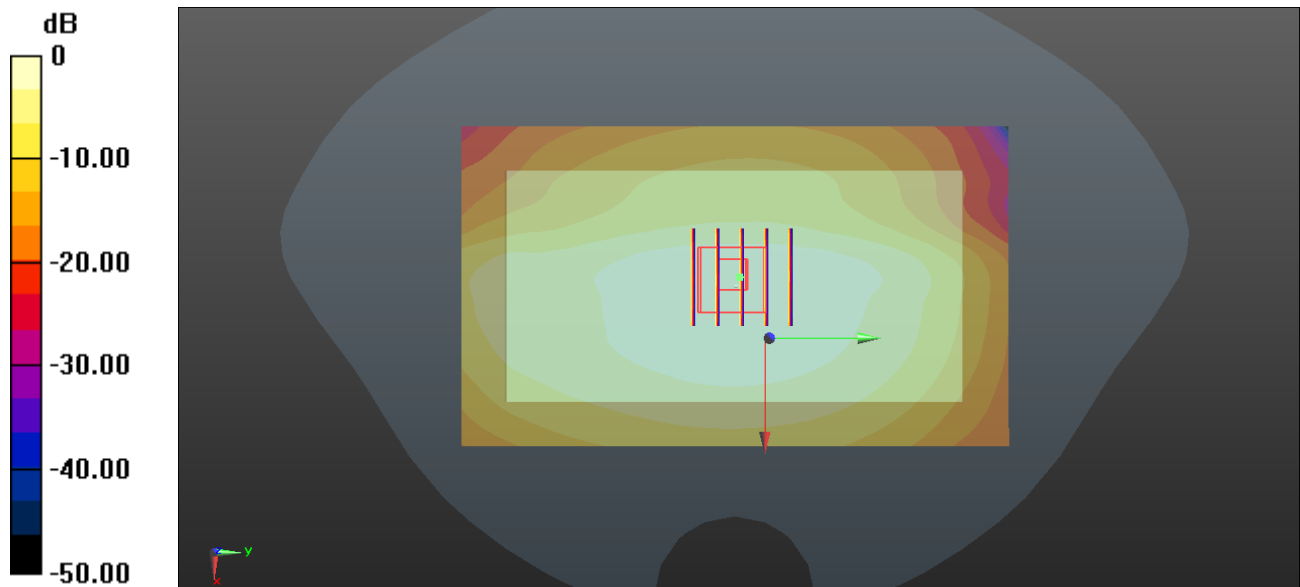

$0 \text{ dB} = 0.491 \text{ W/kg} = -3.09 \text{ dBW/kg}$

37_LTE Band 2_20M_QPSK_1RB_49Offset_Back_15mm_Ch18700

Communication System: LTE ; Frequency: 1860 MHz;Duty Cycle: 1:1

Medium: MSL_1900 Medium parameters used: $f = 1860$ MHz; $\sigma = 1.492$ S/m; $\epsilon_r = 53.636$; $\rho = 1000$ kg/m³

Ambient Temperature : 23.2 °C; Liquid Temperature : 22.8 °C

DASY5 Configuration:

- Probe: EX3DV4 - SN3954; ConvF(8.03, 8.03, 8.03); Calibrated: 2018.1.31;
- Sensor-Surface: 1.4mm (Mechanical Surface Detection)
- Electronics: DAE4 Sn1338; Calibrated: 2017.12.4
- Phantom: SAM1; Type: SAM; Serial: TP-1842
- Measurement SW: DASY52, Version 52.8 (8); SEMCAD X Version 14.6.10 (7331)

Area Scan (61x121x1): Interpolated grid: dx=1.500 mm, dy=1.500 mm

Maximum value of SAR (interpolated) = 1.02 W/kg

Zoom Scan (5x5x7)/Cube 0: Measurement grid: dx=8mm, dy=8mm, dz=5mm

Reference Value = 5.853 V/m; Power Drift = 0.02 dB

Peak SAR (extrapolated) = 1.23 W/kg

SAR(1 g) = 0.814 W/kg; SAR(10 g) = 0.482 W/kg

Maximum value of SAR (measured) = 1.05 W/kg

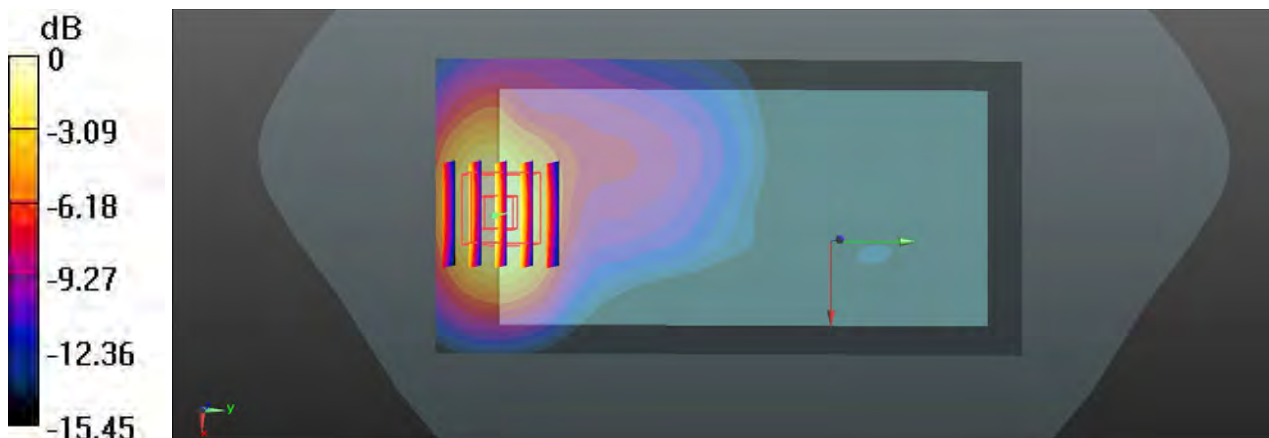

0 dB = 1.05 W/kg = 0.21 dBW/kg

38_LTE Band 5_10M_QPSK_1RB_25Offset_Front_15mm_Ch20525

Communication System: LTE ; Frequency: 836.5 MHz;Duty Cycle: 1:1

Medium: MSL_835 Medium parameters used: $f = 836.5$ MHz; $\sigma = 0.986$ S/m; $\epsilon_r = 56.499$; $\rho = 1000$ kg/m³

Ambient Temperature : 23.4 °C ; Liquid Temperature : 22.7 °C

DASY5 Configuration:

- Probe: ES3DV3 - SN3293; ConvF(6.19, 6.19, 6.19); Calibrated: 2017.9.25;
- Sensor-Surface: 3mm (Mechanical Surface Detection)
- Electronics: DAE4 Sn1279; Calibrated: 2018.1.3
- Phantom: SAM2; Type: SAM ; Serial: TP-1503
- Measurement SW: DASY52, Version 52.8 (8); SEMCAD X Version 14.6.10 (7372)

Area Scan (71x121x1): Interpolated grid: dx=1.500 mm, dy=1.500 mm

Maximum value of SAR (interpolated) = 0.411 W/kg

Zoom Scan (5x5x7)/Cube 0: Measurement grid: dx=8mm, dy=8mm, dz=5mm

Reference Value = 21.66 V/m; Power Drift = -0.02 dB

Peak SAR (extrapolated) = 0.481 W/kg

SAR(1 g) = 0.344 W/kg; SAR(10 g) = 0.260 W/kg

Maximum value of SAR (measured) = 0.410 W/kg

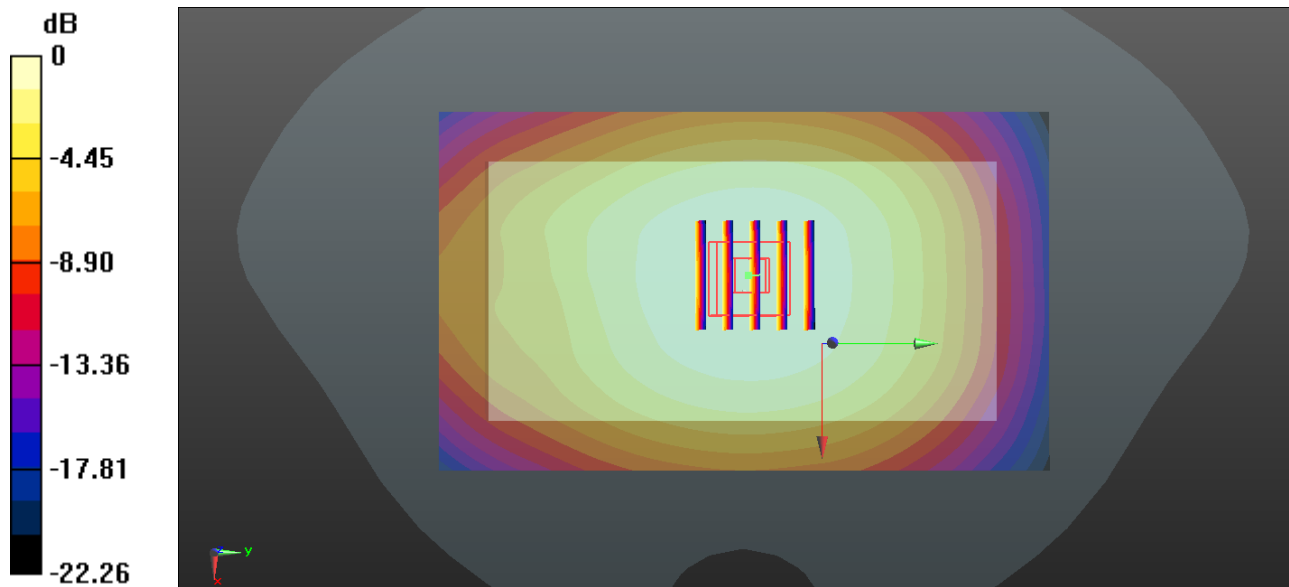

0 dB = 0.411 W/kg = -3.86 dBW/kg

39_LTE Band 7_20M_QPSK_1RB_49Offset_Back_15mm_Ch21350

Communication System: LTE ; Frequency: 2560 MHz;Duty Cycle: 1:1

Medium: MSL_2600 Medium parameters used: $f = 2560$ MHz; $\sigma = 2.173$ S/m; $\epsilon_r = 52.578$; $\rho = 1000$ kg/m³

Ambient Temperature : 23.3 °C ; Liquid Temperature : 22.8 °C

DASY5 Configuration:

- Probe: EX3DV4 - SN3954; ConvF(6.92, 6.92, 6.92); Calibrated: 2018.1.31;
- Sensor-Surface: 1.4mm (Mechanical Surface Detection)
- Electronics: DAE4 Sn1338; Calibrated: 2017.12.4
- Phantom: SAM1; Type: SAM; Serial: TP-1842
- Measurement SW: DASY52, Version 52.8 (8); SEMCAD X Version 14.6.10 (7372)

Area Scan (81x151x1): Interpolated grid: dx=1.200 mm, dy=1.200 mm

Maximum value of SAR (interpolated) = 0.752 W/kg

Zoom Scan (7x7x7)/Cube 0: Measurement grid: dx=5mm, dy=5mm, dz=5mmReference Value

= 6.827 V/m; Power Drift = 0.02 dB

Peak SAR (extrapolated) = 0.908 W/kg

SAR(1 g) = 0.546 W/kg; SAR(10 g) = 0.323 W/kg

Maximum value of SAR (measured) = 0.728 W/kg

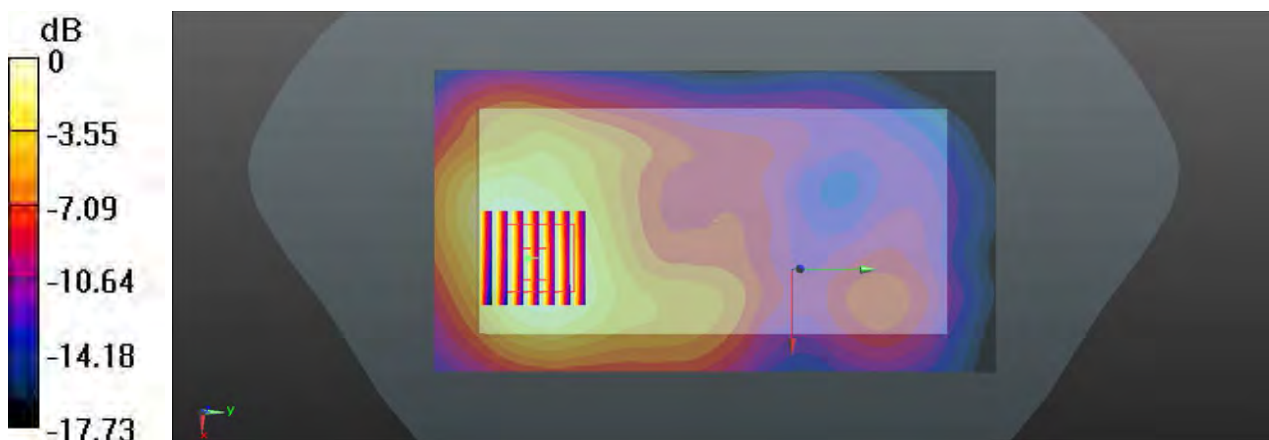

0 dB = 0.728 W/kg = -1.38 dBW/kg

40_LTE Band 12_10M_QPSK_1RB_25Offset_Back_15mm_Ch23095

Communication System: LTE ; Frequency: 707.5 MHz;Duty Cycle: 1:1

Medium: MSL_750 Medium parameters used: $f = 707.5 \text{ MHz}$; $\sigma = 0.923 \text{ S/m}$; $\epsilon_r = 56.587$; $\rho = 1000$

kg/m^3

Ambient Temperature : $23.3 \text{ }^\circ\text{C}$; Liquid Temperature : $22.7 \text{ }^\circ\text{C}$

DASY5 Configuration:

- Probe: ES3DV3 - SN3293; ConvF(6.43, 6.43, 6.43); Calibrated: 2017.9.25;
- Sensor-Surface: 3mm (Mechanical Surface Detection)
- Electronics: DAE4 Sn1279; Calibrated: 2018.1.3
- Phantom: SAM2; Type: SAM ; Serial: TP-1503
- Measurement SW: DASY52, Version 52.8 (8); SEMCAD X Version 14.6.10 (7372)

Area Scan (71x121x1): Interpolated grid: $dx=1.500 \text{ mm}$, $dy=1.500 \text{ mm}$

Maximum value of SAR (interpolated) = 0.335 W/kg

Zoom Scan (5x5x7)/Cube 0: Measurement grid: $dx=8\text{mm}$, $dy=8\text{mm}$, $dz=5\text{mm}$

Reference Value = 19.52 V/m ; Power Drift = 0.03 dB

Peak SAR (extrapolated) = 0.381 W/kg

SAR(1 g) = 0.283 W/kg ; SAR(10 g) = 0.220 W/kg

Maximum value of SAR (measured) = 0.331 W/kg

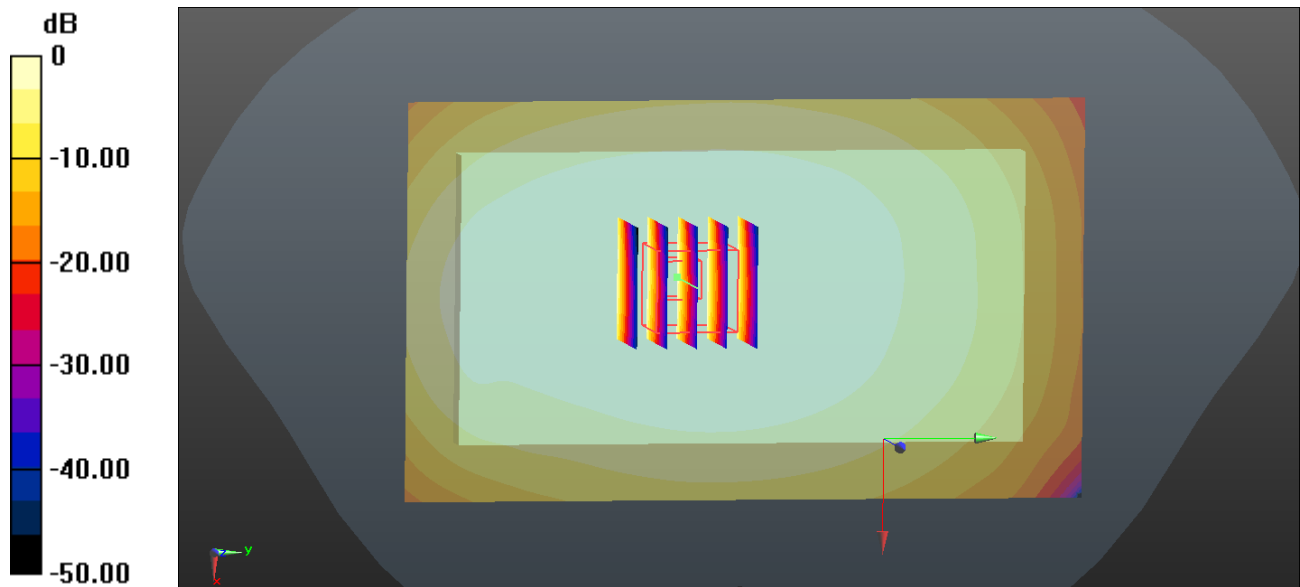

$0 \text{ dB} = 0.335 \text{ W/kg} = -4.75 \text{ dBW/kg}$

41_LTE Band 13_10M_QPSK_1RB_25Offset_Back_15mm_Ch23230

Communication System: LTE ; Frequency: 782 MHz;Duty Cycle: 1:1

Medium: MSL_750 Medium parameters used: $f = 782 \text{ MHz}$; $\sigma = 0.999 \text{ S/m}$; $\epsilon_r = 55.861$; $\rho = 1000$

kg/m^3

Ambient Temperature : $23.3 \text{ }^\circ\text{C}$; Liquid Temperature : $22.7 \text{ }^\circ\text{C}$

DASY5 Configuration:

- Probe: ES3DV3 - SN3293; ConvF(6.43, 6.43, 6.43); Calibrated: 2017.9.25;
- Sensor-Surface: 3mm (Mechanical Surface Detection)
- Electronics: DAE4 Sn1279; Calibrated: 2018.1.3
- Phantom: SAM2; Type: SAM ; Serial: TP-1503
- Measurement SW: DASY52, Version 52.8 (8); SEMCAD X Version 14.6.10 (7372)

Area Scan (71x121x1): Interpolated grid: $dx=1.500 \text{ mm}$, $dy=1.500 \text{ mm}$

Maximum value of SAR (interpolated) = 0.464 W/kg

Zoom Scan (5x5x7)/Cube 0: Measurement grid: $dx=8\text{mm}$, $dy=8\text{mm}$, $dz=5\text{mm}$

Reference Value = 22.82 V/m ; Power Drift = -0.00 dB

Peak SAR (extrapolated) = 0.531 W/kg

SAR(1 g) = 0.391 W/kg ; SAR(10 g) = 0.301 W/kg

Maximum value of SAR (measured) = 0.459 W/kg

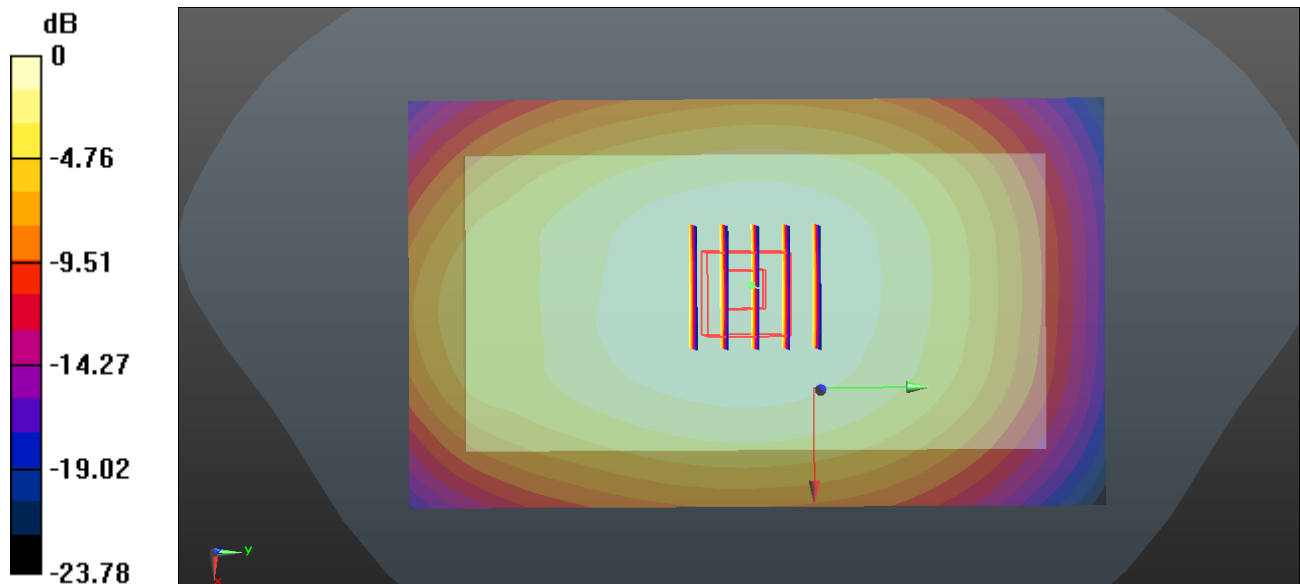

$0 \text{ dB} = 0.464 \text{ W/kg} = -3.33 \text{ dBW/kg}$

42_LTE Band 66_20M_QPSK_1RB_49Offset_Back_15mm_Ch132572

Communication System: LTE ; Frequency: 1770 MHz;Duty Cycle: 1:1

Medium: MSL_1750 Medium parameters used: $f = 1770$ MHz; $\sigma = 1.511$ S/m; $\epsilon_r = 54.69$; $\rho = 1000$ kg/m³

Ambient Temperature : 23.3 °C ; Liquid Temperature : 22.6 °C

DASY5 Configuration:

- Probe: EX3DV4 - SN3954; ConvF(8.31, 8.31, 8.31); Calibrated: 2018.1.31;
- Sensor-Surface: 1.4mm (Mechanical Surface Detection)
- Electronics: DAE4 Sn1338; Calibrated: 2017.12.4
- Phantom: SAM3; Type: SAM; Serial: TP-1839
- Measurement SW: DASY52, Version 52.8 (8); SEMCAD X Version 14.6.10 (7331)

Area Scan (61x121x1): Interpolated grid: dx=1.500 mm, dy=1.500 mm

Maximum value of SAR (interpolated) = 1.02 W/kg

Zoom Scan (5x5x7)/Cube 0: Measurement grid: dx=8mm, dy=8mm, dz=5mm

Reference Value = 3.438 V/m; Power Drift = 0.16 dB

Peak SAR (extrapolated) = 1.25 W/kg

SAR(1 g) = 0.831 W/kg; SAR(10 g) = 0.493 W/kg

Maximum value of SAR (measured) = 1.07 W/kg

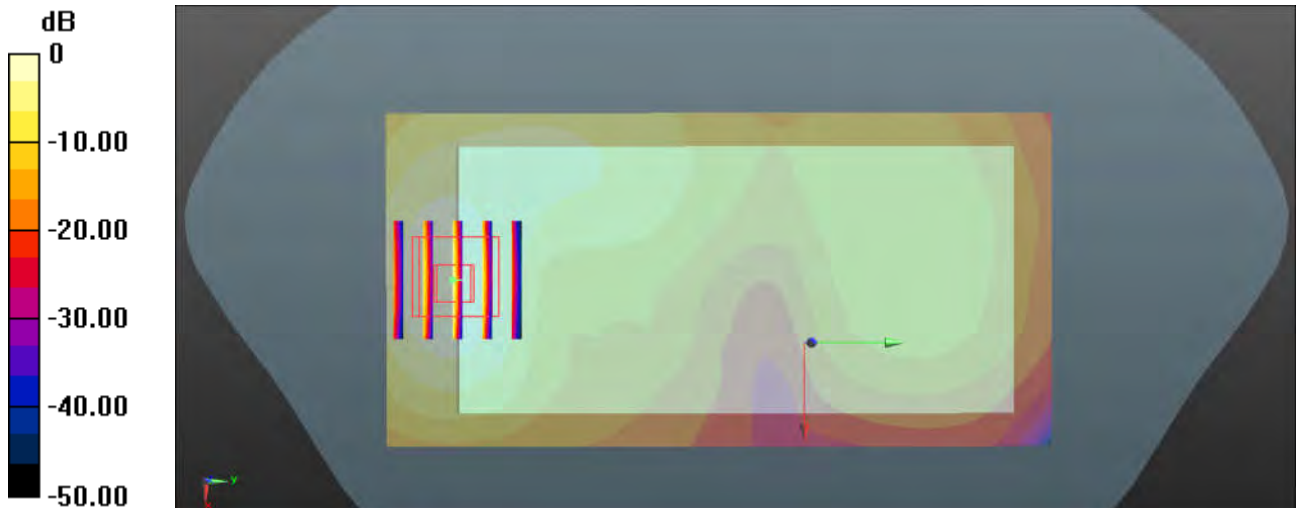

0 dB = 1.02 W/kg = 0.09 dBW/kg

43_LTE Band 38_20M_QPSK_1_49_Front_15mm_Ch38150

Communication System: LTE; Frequency: 2610 MHz; Duty Cycle: 1:1.59

Medium: MSL_2600_180619 Medium parameters used : $f = 2610$ MHz; $\sigma = 2.203$ S/m; $\epsilon_r = 50.628$; $\rho = 1000$ kg/m³

Ambient Temperature : 23.5 °C ; Liquid Temperature : 22.5 °C

DASY5 Configuration:

- Probe: EX3DV4 - SN3925; ConvF(7.59, 7.59, 7.59); Calibrated: 2018/5/31
- Sensor-Surface: 1.4mm (Mechanical Surface Detection)
- Electronics: DAE3 Sn495; Calibrated: 2018/5/24
- Phantom: SAM_Right; Type: QD000P40CD; Serial: 1884
- Measurement SW: DASY52, Version 52.10 (1); SEMCAD X Version 14.6.11 (7437)

Area Scan (91x61x1): Interpolated grid: dx=1.200 mm, dy=1.200 mm

Maximum value of SAR (interpolated) = 0.305 W/kg

Zoom Scan (7x7x7)/Cube 0: Measurement grid: dx=5mm, dy=5mm, dz=5mm

Reference Value = 11.49 V/m; Power Drift = -0.04 dB

Peak SAR (extrapolated) = 0.379 W/kg

SAR(1 g) = 0.200 W/kg; SAR(10 g) = 0.111 W/kg

Maximum value of SAR (measured) = 0.306 W/kg

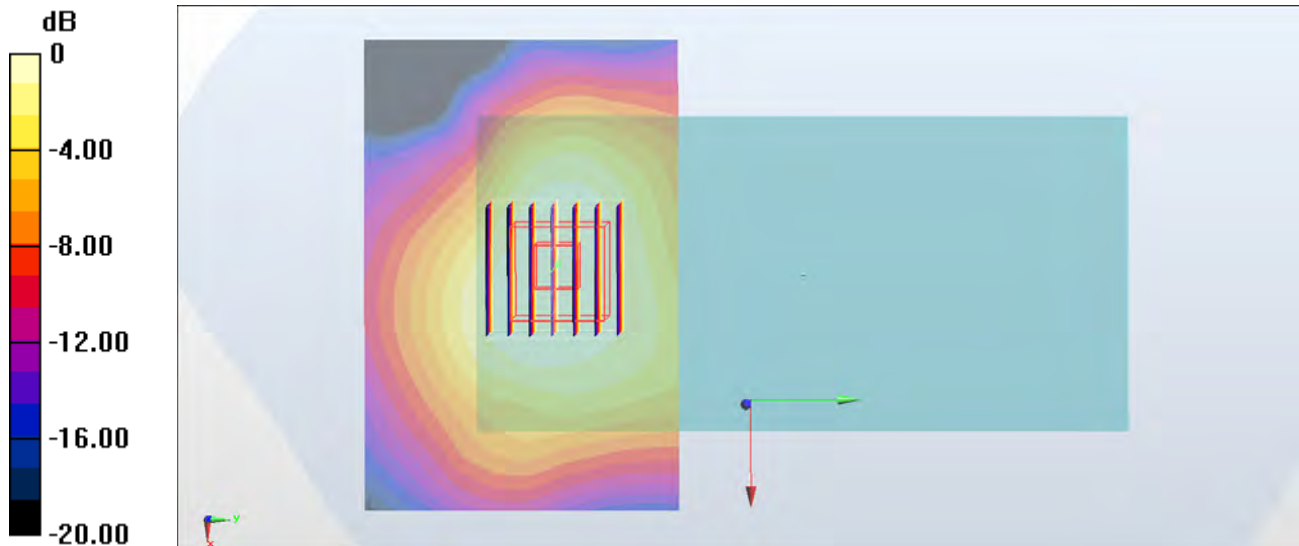

0 dB = 0.306 W/kg = -5.14 dBW/kg

44_WLAN2.4GHz_802.11b 1Mbps_Back_15mm_Ch6

Communication System: 802.11b; Frequency: 2437 MHz; Duty Cycle: 1:1

Medium: MSL2450_180620 Medium parameters used : $f = 2437$ MHz; $\sigma = 1.965$ S/m; $\epsilon_r = 52.388$; $\rho = 1000$ kg/m³

Ambient Temperature : 23.5 °C; Liquid Temperature : 22.5 °C

DASY5 Configuration:

- Probe: ES3DV3 - SN3169; ConvF(4.4, 4.4, 4.4) @ 2437 MHz; Calibrated: 2018/5/28
- Sensor-Surface: 3mm (Mechanical Surface Detection)
- Electronics: DAE4 Sn1424; Calibrated: 2018/1/18
- Phantom: SAM_Right; Type: SAM; Serial: TP:1479
- Measurement SW: DASY52, Version 52.10 (1); SEMCAD X Version 14.6.11 (7439)

Area Scan (81x141x1): Interpolated grid: dx=1.200 mm, dy=1.200 mm

Maximum value of SAR (interpolated) = 0.0807 W/kg

Zoom Scan (7x7x7)/Cube 0: Measurement grid: dx=5mm, dy=5mm, dz=5mm

Reference Value = 6.668 V/m; Power Drift = -0.06 dB

Peak SAR (extrapolated) = 0.132 W/kg

SAR(1 g) = 0.066 W/kg; SAR(10 g) = 0.038 W/kg

Maximum value of SAR (measured) = 0.0827 W/kg

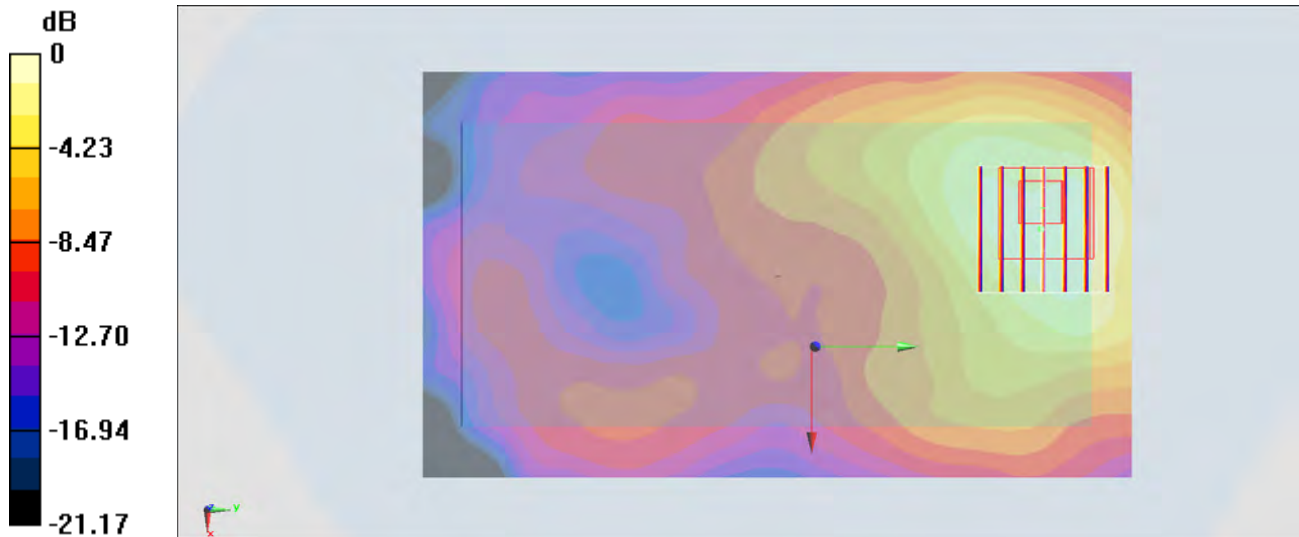

0 dB = 0.0827 W/kg = -10.82 dBW/kg

45_WLAN5GHz_802.11n-HT40 MCS0_Front_15mm_Ch62

Communication System: 802.11n ; Frequency: 5310 MHz;Duty Cycle: 1:1.065

Medium: MSL_5G_180620 Medium parameters used: $f = 5310$ MHz; $\sigma = 5.566$ S/m; $\epsilon_r = 46.747$; $\rho = 1000$ kg/m³

Ambient Temperature : 23.5 °C ; Liquid Temperature : 22.5 °C

DASY5 Configuration:

- Probe: EX3DV4 - SN3976; ConvF(4.92, 4.92, 4.92) @ 5310 MHz; Calibrated: 2018/1/23
- Sensor-Surface: 1.4mm (Mechanical Surface Detection)
- Electronics: DAE4 Sn778; Calibrated: 2018/5/25
- Phantom: SAM_Right; Type: SAM; Serial: TP:1479
- Measurement SW: DASY52, Version 52.10 (1);SEMCAD X Version 14.6.11 (7439)

Area Scan (101x101x1): Interpolated grid: dx=1.000 mm, dy=1.000 mm

Maximum value of SAR (interpolated) = 0.0238 W/kg

Zoom Scan (7x7x7)/Cube 0: Measurement grid: dx=4mm, dy=4mm, dz=1.4mm

Reference Value = 1.763 V/m; Power Drift = -0.11 dB

Peak SAR (extrapolated) = 0.0840 W/kg

SAR(1 g) = 0.00731 W/kg; SAR(10 g) = 0.000893 W/kg

Maximum value of SAR (measured) = 0.0357 W/kg

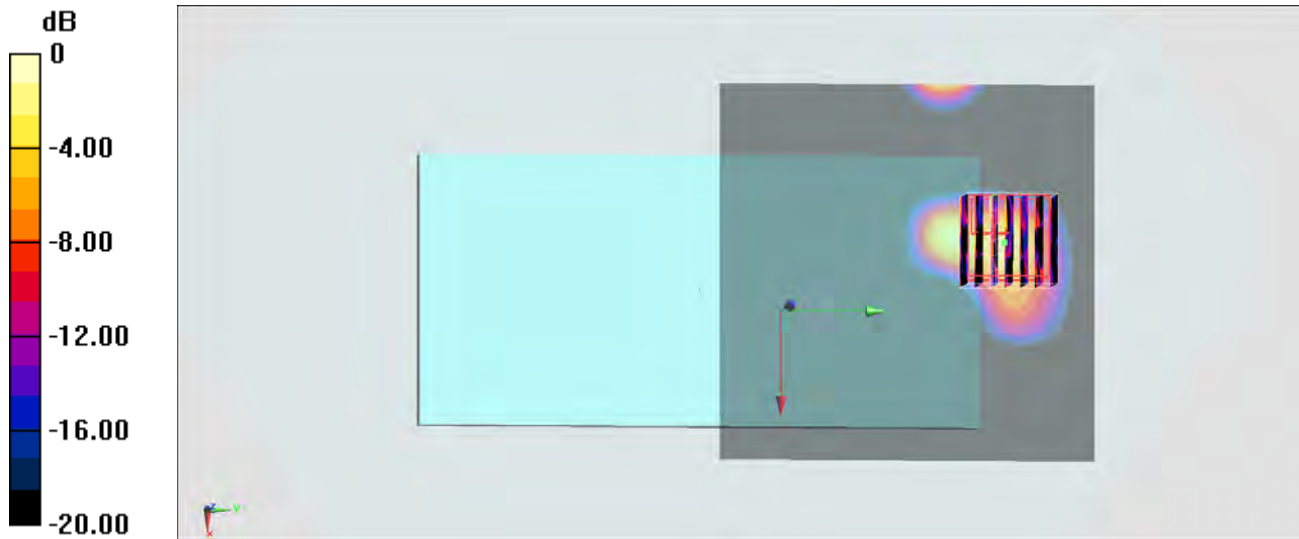

0 dB = 0.0357 W/kg = -14.47 dBW/kg

46_WLAN5GHz_802.11n-HT40 MCS0_Front_15mm_Ch134

Communication System: 802.11n; Frequency: 5670 MHz; Duty Cycle: 1:1.065

Medium: MSL_5G_180620 Medium parameters used: $f = 5670$ MHz; $\sigma = 6.028$ S/m; $\epsilon_r = 46.092$; $\rho = 1000$ kg/m³

Ambient Temperature : 23.5 °C ; Liquid Temperature : 22.5 °C

DASY5 Configuration:

- Probe: EX3DV4 - SN3976; ConvF(4.28, 4.28, 4.28) @ 5670 MHz; Calibrated: 2018/1/23
- Sensor-Surface: 1.4mm (Mechanical Surface Detection)
- Electronics: DAE4 Sn778; Calibrated: 2018/5/25
- Phantom: SAM_Right; Type: SAM; Serial: TP:1479
- Measurement SW: DASY52, Version 52.10 (1); SEMCAD X Version 14.6.11 (7439)

Area Scan (81x101x1): Interpolated grid: dx=1.000 mm, dy=1.000 mm

Maximum value of SAR (interpolated) = 0.00853 W/kg

Zoom Scan (7x7x7)/Cube 0: Measurement grid: dx=4mm, dy=4mm, dz=1.4mm

Reference Value = 0.4820 V/m; Power Drift = -0.13 dB

Peak SAR (extrapolated) = 0.120 W/kg

SAR(1 g) = 0.00387 W/kg; SAR(10 g) = 0.000722 W/kg

Maximum value of SAR (measured) = 0.0286 W/kg

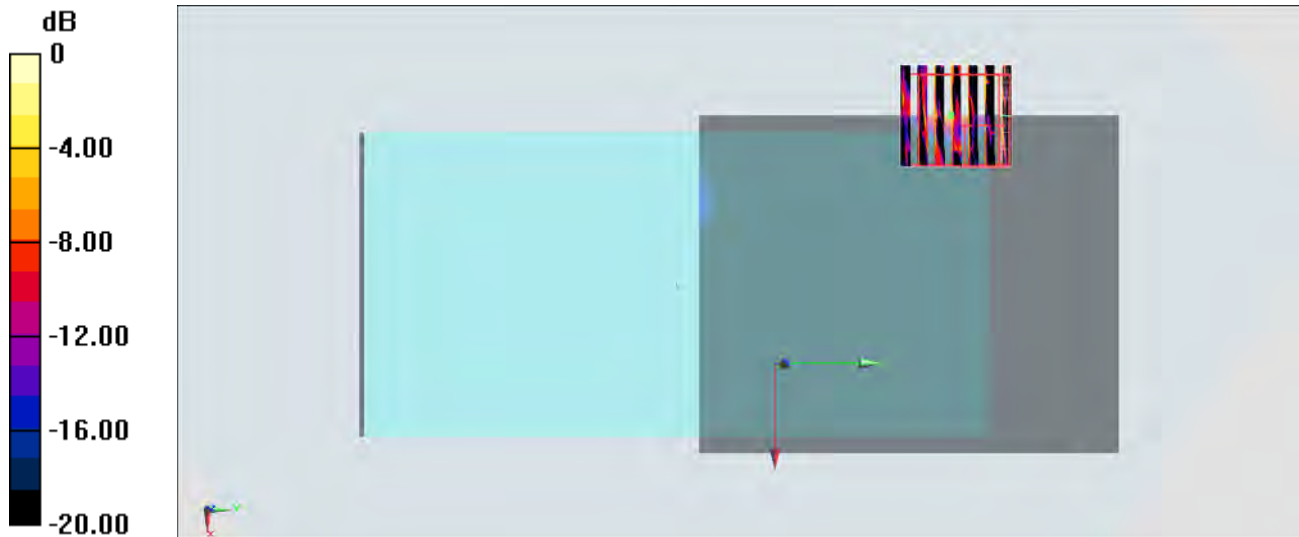

0 dB = 0.0286 W/kg = -15.44 dBW/kg

47_WLAN5GHz_802.11n-HT40 MCS0_Front_15mm_Ch151

Communication System: 802.11n; Frequency: 5755 MHz; Duty Cycle: 1:1.065

Medium: MSL_5G_180620 Medium parameters used : $f = 5755$ MHz; $\sigma = 6.14$ S/m; $\epsilon_r = 45.92$; $\rho = 1000$ kg/m³

Ambient Temperature : 23.5 °C ; Liquid Temperature : 22.5 °C

DASY5 Configuration:

- Probe: EX3DV4 - SN3976; ConvF(4.46, 4.46, 4.46) @ 5755 MHz; Calibrated: 2018/1/23
- Sensor-Surface: 1.4mm (Mechanical Surface Detection)
- Electronics: DAE4 Sn778; Calibrated: 2018/5/25
- Phantom: SAM_Right; Type: SAM; Serial: TP:1479
- Measurement SW: DASY52, Version 52.10 (1); SEMCAD X Version 14.6.11 (7439)

Area Scan (101x81x1): Interpolated grid: dx=1.000 mm, dy=1.000 mm

Maximum value of SAR (interpolated) = 0.000932 W/kg

Zoom Scan (7x7x7)/Cube 0: Measurement grid: dx=4mm, dy=4mm, dz=1.4mm

Reference Value = 0.8250 V/m; Power Drift = -0.11 dB

Peak SAR (extrapolated) = 0 W/kg

SAR(1 g) = n.a. ; SAR(10 g) = n.a.

Maximum value of SAR (measured) = 0.00822 W/kg

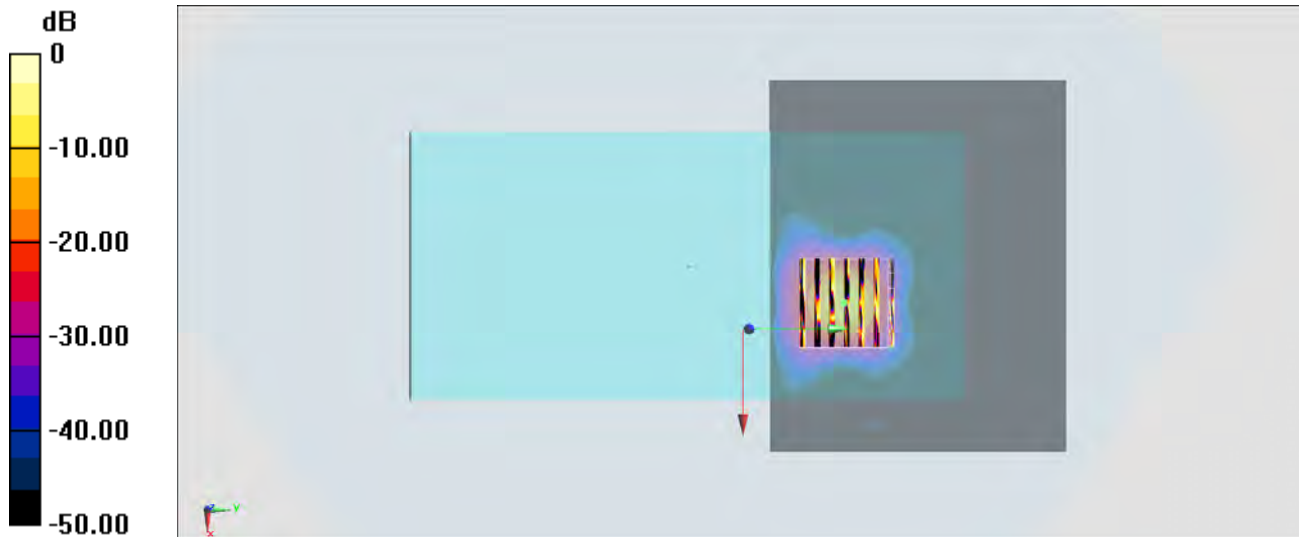

0 dB = 0.00822 W/kg = -20.85 dBW/kg