

#01_GSM850_GPRS (1 Tx slot)_Left Cheek_Ch251

Communication System: GSM850; Frequency: 848.8 MHz; Duty Cycle: 1:8.3

Medium: HSL_850_181106 Medium parameters used: $f = 849$ MHz; $\sigma = 0.882$ S/m; $\epsilon_r = 41.46$; $\rho = 1000$ kg/m³

Ambient Temperature : 23.8 °C ; Liquid Temperature : 22.8 °C

DASY5 Configuration:

- Probe: EX3DV4 - SN3976; ConvF(10.19, 10.19, 10.19) ; Calibrated: 2018/1/23
- Sensor-Surface: 1.4mm (Mechanical Surface Detection)
- Electronics: DAE4 Sn1424; Calibrated: 2018/1/18
- Phantom: SAM_Right; Type: SAM; Serial: TP:1479
- Measurement SW: DASY52, Version 52.10 (1); SEMCAD X Version 14.6.11 (7439)

Area Scan (61x121x1): Interpolated grid: dx=1.500 mm, dy=1.500 mm

Maximum value of SAR (interpolated) = 1.24 W/kg

Zoom Scan (6x6x7)/Cube 0: Measurement grid: dx=8mm, dy=8mm, dz=5mm

Reference Value = 31.08 V/m; Power Drift = 0.02 dB

Peak SAR (extrapolated) = 1.29 W/kg

SAR(1 g) = 0.772 W/kg; SAR(10 g) = 0.508 W/kg

Maximum value of SAR (measured) = 1.09 W/kg

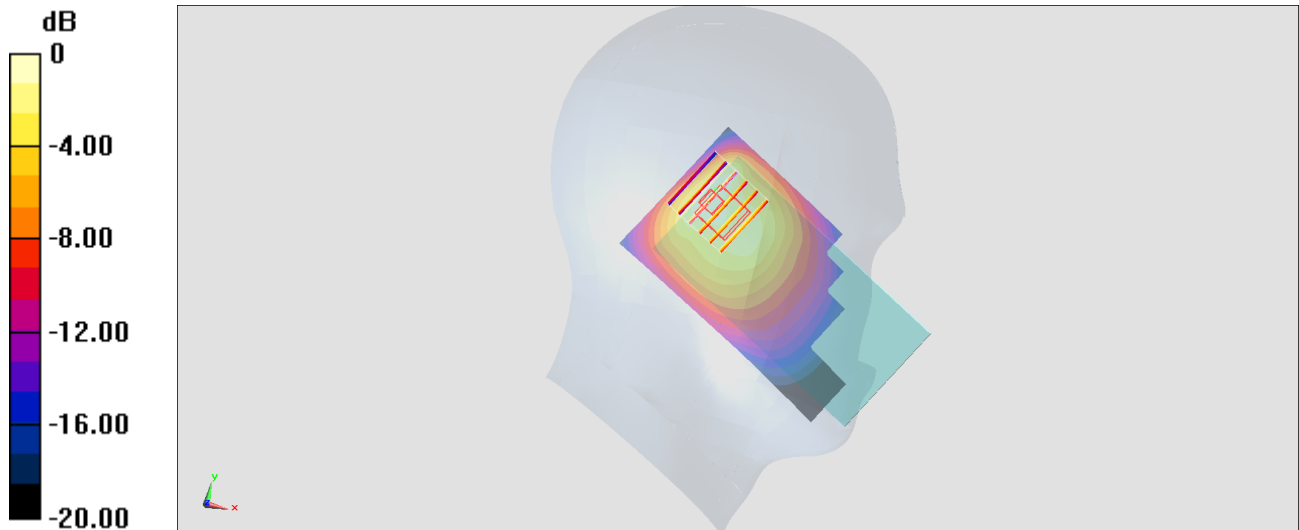

0 dB = 1.09 W/kg = 0.37 dBW/kg

#02_GSM1900_GPRS (1 Tx slot)_Right Cheek_Ch512

Communication System: PCS; Frequency: 1850.2 MHz; Duty Cycle: 1:8.3

Medium: HSL_1900_181109 Medium parameters used: $f = 1850.2$ MHz; $\sigma = 1.391$ S/m; $\epsilon_r = 38.341$; $\rho = 1000$ kg/m³

Ambient Temperature : 23.2 °C ; Liquid Temperature : 22.2 °C

DASY5 Configuration:

- Probe: EX3DV4 - SN3976; ConvF(8.71, 8.71, 8.71) ; Calibrated: 2018/1/23
- Sensor-Surface: 1.4mm (Mechanical Surface Detection)
- Electronics: DAE4 Sn1424; Calibrated: 2018/1/18
- Phantom: SAM_Left; Type: QD000P40CD; Serial: TP:1477
- Measurement SW: DASY52, Version 52.10 (1); SEMCAD X Version 14.6.11 (7439)

Area Scan (61x121x1): Interpolated grid: dx=1.500 mm, dy=1.500 mm

Maximum value of SAR (interpolated) = 0.0711 W/kg

Zoom Scan (5x5x7)/Cube 0: Measurement grid: dx=8mm, dy=8mm, dz=5mm

Reference Value = 6.382 V/m; Power Drift = 0.11 dB

Peak SAR (extrapolated) = 0.0830 W/kg

SAR(1 g) = 0.054 W/kg; SAR(10 g) = 0.034 W/kg

Maximum value of SAR (measured) = 0.0739 W/kg

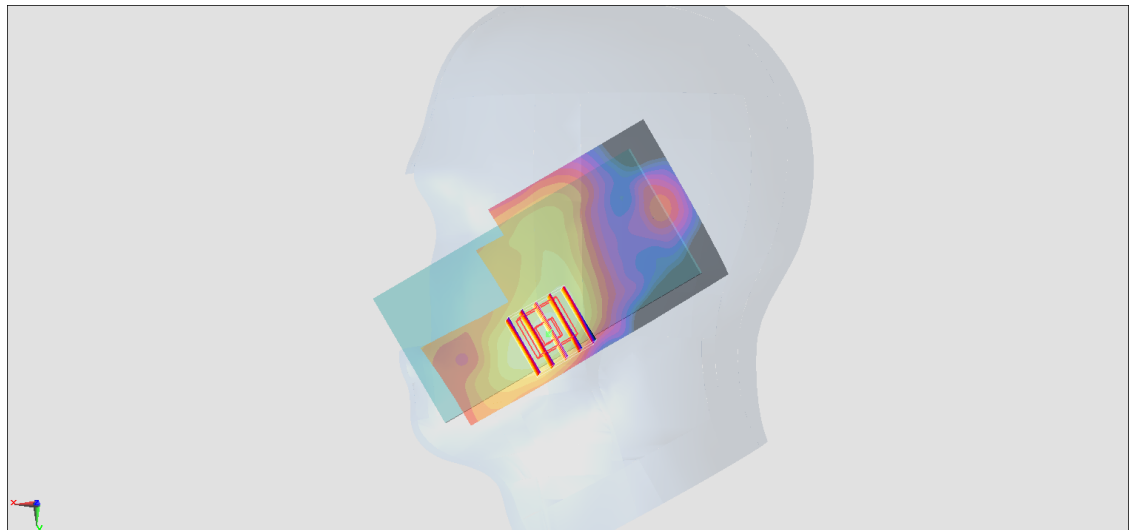
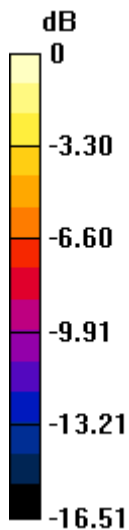

#03_WCDMA II_RMC 12.2Kbps_Right Cheek_Ch9262

Communication System: WCDMA; Frequency: 1852.4 MHz; Duty Cycle: 1:1

Medium: HSL_1900_181109 Medium parameters used: $f = 1852.4$ MHz; $\sigma = 1.393$ S/m; $\epsilon_r = 38.33$; $\rho = 1000$ kg/m³

Ambient Temperature : 23.2 °C; Liquid Temperature : 22.2 °C

DASY5 Configuration:

- Probe: EX3DV4 - SN3976; ConvF(8.71, 8.71, 8.71) ; Calibrated: 2018/1/23
- Sensor-Surface: 1.4mm (Mechanical Surface Detection)
- Electronics: DAE4 Sn1424; Calibrated: 2018/1/18
- Phantom: SAM_Left; Type: QD000P40CD; Serial: TP:1477
- Measurement SW: DASY52, Version 52.10 (1); SEMCAD X Version 14.6.11 (7439)

Area Scan (61x121x1): Interpolated grid: dx=1.500 mm, dy=1.500 mm

Maximum value of SAR (interpolated) = 0.252 W/kg

Zoom Scan (5x5x7)/Cube 0: Measurement grid: dx=8mm, dy=8mm, dz=5mm

Reference Value = 11.02 V/m; Power Drift = -0.06 dB

Peak SAR (extrapolated) = 0.279 W/kg

SAR(1 g) = 0.181 W/kg; SAR(10 g) = 0.114 W/kg

Maximum value of SAR (measured) = 0.242 W/kg

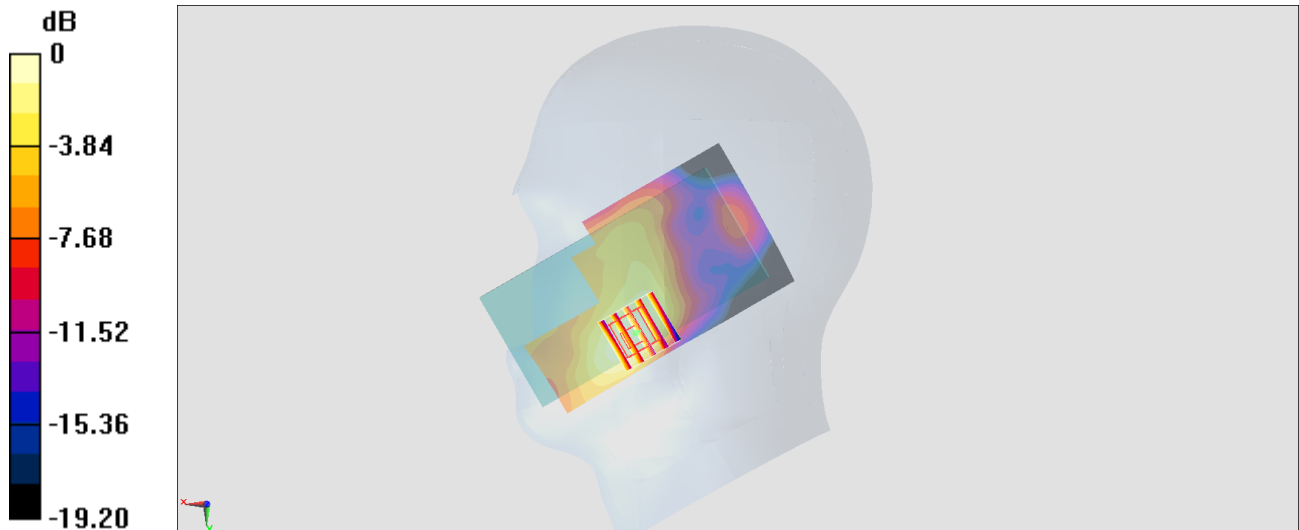

0 dB = 0.242 W/kg = -6.16 dBW/kg

#04_WCDMA V_RMC 12.2Kbps_Left Cheek_Ch4233

Communication System: WCDMA; Frequency: 846.6 MHz; Duty Cycle: 1:1

Medium: HSL_850_181106 Medium parameters used: $f = 847$ MHz; $\sigma = 0.88$ S/m; $\epsilon_r = 41.485$; $\rho = 1000$ kg/m³

Ambient Temperature : 23.8 °C ; Liquid Temperature : 22.8 °C

DASY5 Configuration:

- Probe: EX3DV4 - SN3976; ConvF(10.19, 10.19, 10.19) ; Calibrated: 2018/1/23
- Sensor-Surface: 1.4mm (Mechanical Surface Detection)
- Electronics: DAE4 Sn1424; Calibrated: 2018/1/18
- Phantom: SAM_Right; Type: SAM; Serial: TP:1479
- Measurement SW: DASY52, Version 52.10 (1); SEMCAD X Version 14.6.11 (7439)

Area Scan (61x121x1): Interpolated grid: dx=1.500 mm, dy=1.500 mm

Maximum value of SAR (interpolated) = 1.53 W/kg

Zoom Scan (5x5x7)/Cube 0: Measurement grid: dx=8mm, dy=8mm, dz=5mm

Reference Value = 34.80 V/m; Power Drift = 0.03 dB

Peak SAR (extrapolated) = 1.72 W/kg

SAR(1 g) = 0.991 W/kg; SAR(10 g) = 0.634 W/kg

Maximum value of SAR (measured) = 1.40 W/kg

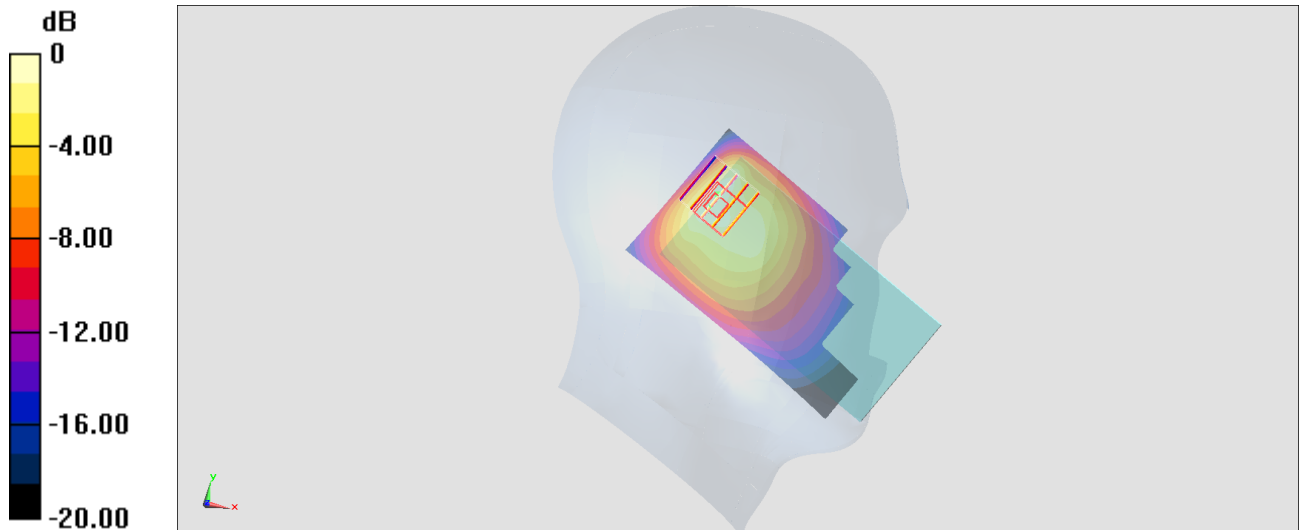

0 dB = 1.40 W/kg = 1.46 dBW/kg

#05_LTE Band 5_10M_QPSK_1_25_Right Cheek_Ch20525

Communication System: LTE; Frequency: 836.5 MHz; Duty Cycle: 1:1

Medium: HSL_850_181106 Medium parameters used: $f = 836.5$ MHz; $\sigma = 0.87$ S/m; $\epsilon_r = 41.611$; $\rho = 1000$ kg/m³

Ambient Temperature : 23.8 °C ; Liquid Temperature : 22.8 °C

DASY5 Configuration:

- Probe: EX3DV4 - SN3976; ConvF(10.19, 10.19, 10.19) ; Calibrated: 2018/1/23
- Sensor-Surface: 1.4mm (Mechanical Surface Detection)
- Electronics: DAE4 Sn1424; Calibrated: 2018/1/18
- Phantom: SAM_Right; Type: SAM; Serial: TP:1479
- Measurement SW: DASY52, Version 52.10 (1); SEMCAD X Version 14.6.11 (7439)

Area Scan (61x121x1): Interpolated grid: dx=1.500 mm, dy=1.500 mm

Maximum value of SAR (interpolated) = 0.899 W/kg

Zoom Scan (5x5x7)/Cube 0: Measurement grid: dx=8mm, dy=8mm, dz=5mm

Reference Value = 29.68 V/m; Power Drift = -0.01 dB

Peak SAR (extrapolated) = 1.28 W/kg

SAR(1 g) = 0.712 W/kg; SAR(10 g) = 0.448 W/kg

Maximum value of SAR (measured) = 1.04 W/kg

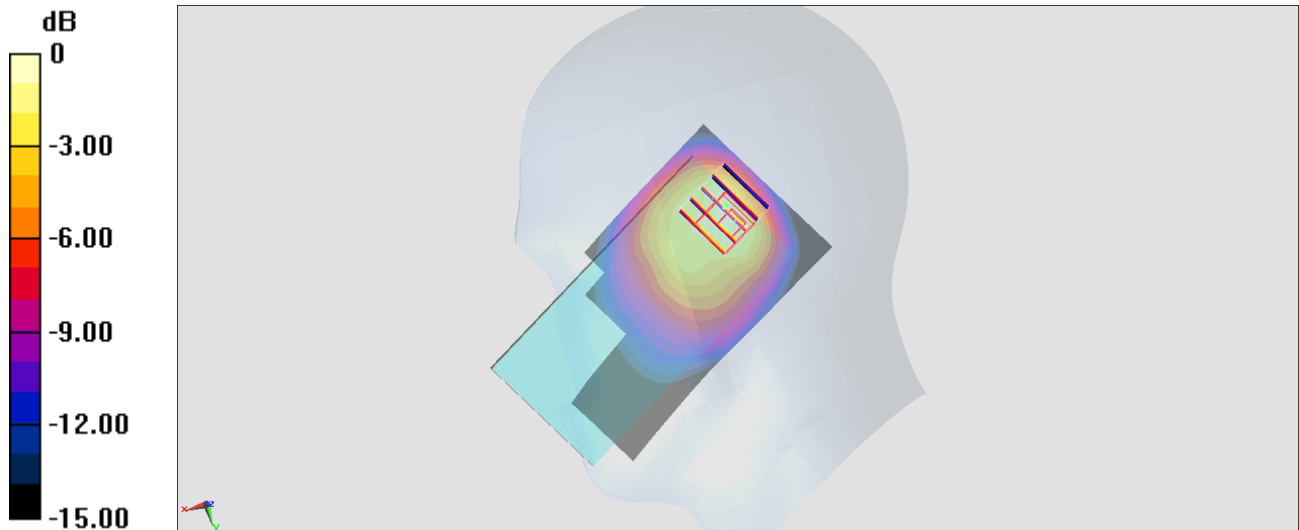

0 dB = 1.04 W/kg = 0.17 dBW/kg

#06_LTE Band 7_20M_QPSK_1_49_Right Cheek_Ch21350

Communication System: LTE; Frequency: 2560 MHz; Duty Cycle: 1:1

Medium: HSL_2600_181108 Medium parameters used: $f = 2560$ MHz; $\sigma = 1.944$ S/m; $\epsilon_r = 38.14$; $\rho = 1000$ kg/m³

Ambient Temperature : 23.3 °C ; Liquid Temperature : 22.3 °C

DASY5 Configuration:

- Probe: EX3DV4 - SN3976; ConvF(7.54, 7.54, 7.54) ; Calibrated: 2018/1/23
- Sensor-Surface: 1.4mm (Mechanical Surface Detection)
- Electronics: DAE4 Sn1424; Calibrated: 2018/1/18
- Phantom: SAM_Left; Type: QD000P40CD; Serial: TP:1477
- Measurement SW: DASY52, Version 52.10 (1); SEMCAD X Version 14.6.11 (7439)

Area Scan (81x151x1): Interpolated grid: dx=1.200 mm, dy=1.200 mm

Maximum value of SAR (interpolated) = 0.317 W/kg

Zoom Scan (7x7x7)/Cube 0: Measurement grid: dx=5mm, dy=5mm, dz=5mm

Reference Value = 10.06 V/m; Power Drift = -0.08 dB

Peak SAR (extrapolated) = 0.409 W/kg

SAR(1 g) = 0.224 W/kg; SAR(10 g) = 0.120 W/kg

Maximum value of SAR (measured) = 0.339 W/kg

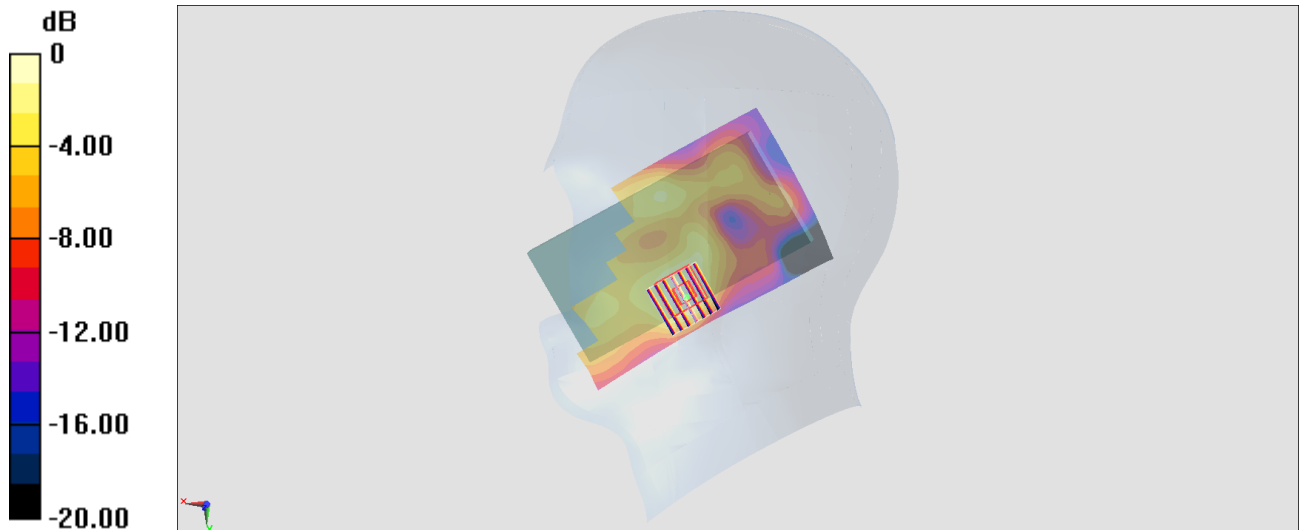

0 dB = 0.339 W/kg = -4.70 dBW/kg

#07_LTE Band 38_20M_QPSK_1_49_Right Cheek_Ch38000

Communication System: LTE; Frequency: 2595 MHz; Duty Cycle: 1:1.59

Medium: HSL_2600_181108 Medium parameters used: $f = 2595$ MHz; $\sigma = 1.988$ S/m; $\epsilon_r = 38.002$; $\rho = 1000$ kg/m³

Ambient Temperature : 23.3 °C ; Liquid Temperature : 22.3 °C

DASY5 Configuration:

- Probe: EX3DV4 - SN3976; ConvF(7.54, 7.54, 7.54) ; Calibrated: 2018/1/23
- Sensor-Surface: 1.4mm (Mechanical Surface Detection)
- Electronics: DAE4 Sn1424; Calibrated: 2018/1/18
- Phantom: SAM_Left; Type: QD000P40CD; Serial: TP:1477
- Measurement SW: DASY52, Version 52.10 (1); SEMCAD X Version 14.6.11 (7439)

Area Scan (81x151x1): Interpolated grid: dx=1.200 mm, dy=1.200 mm

Maximum value of SAR (interpolated) = 0.273 W/kg

Zoom Scan (7x7x7)/Cube 0: Measurement grid: dx=5mm, dy=5mm, dz=5mm

Reference Value = 9.503 V/m; Power Drift = -0.16 dB

Peak SAR (extrapolated) = 0.334 W/kg

SAR(1 g) = 0.176 W/kg; SAR(10 g) = 0.092 W/kg

Maximum value of SAR (measured) = 0.267 W/kg

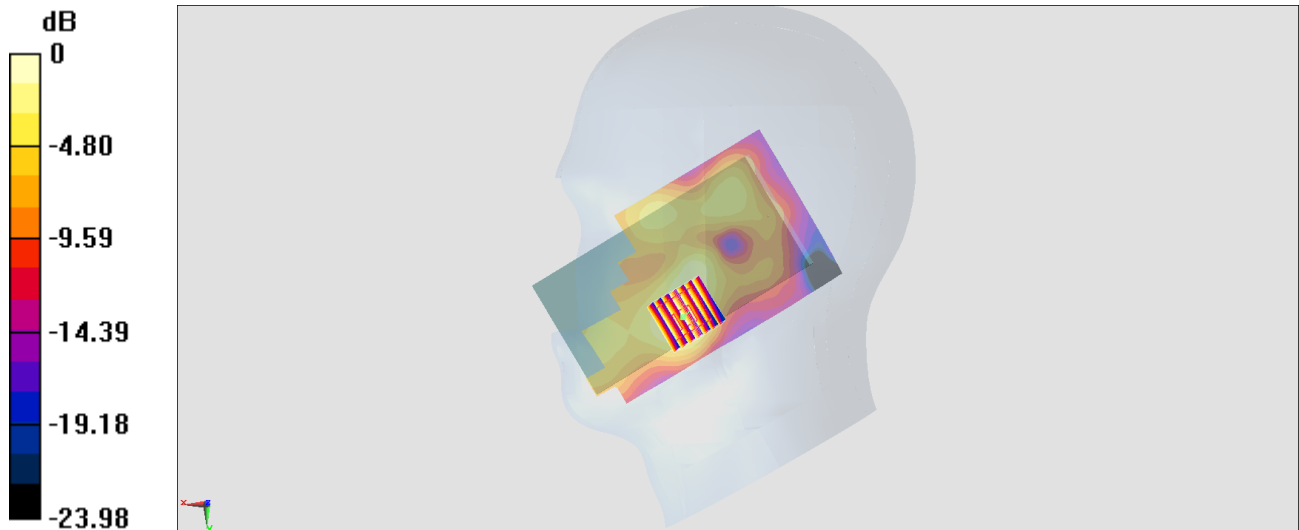

0 dB = 0.267 W/kg = -5.73 dBW/kg

#08_WLAN2.4GHz_802.11b 1Mbps_Right Tilted_Ch11

Communication System: 802.11b; Frequency: 2462 MHz; Duty Cycle: 1:1

Medium: HSL_2450_181108 Medium parameters used: $f = 2462$ MHz; $\sigma = 1.829$ S/m; $\epsilon_r = 38.547$; $\rho = 1000$ kg/m³

Ambient Temperature : 23.3 °C ; Liquid Temperature : 22.3 °C

DASY5 Configuration:

- Probe: EX3DV4 - SN3976; ConvF(7.75, 7.75, 7.75) ; Calibrated: 2018/1/23
- Sensor-Surface: 1.4mm (Mechanical Surface Detection)
- Electronics: DAE4 Sn1424; Calibrated: 2018/1/18
- Phantom: SAM_Left; Type: QD000P40CD; Serial: TP:1477
- Measurement SW: DASY52, Version 52.10 (1); SEMCAD X Version 14.6.11 (7439)

Area Scan (81x151x1): Interpolated grid: dx=1.200 mm, dy=1.200 mm

Maximum value of SAR (interpolated) = 0.427 W/kg

Zoom Scan (7x7x7)/Cube 0: Measurement grid: dx=5mm, dy=5mm, dz=5mm

Reference Value = 11.82 V/m; Power Drift = -0.04 dB

Peak SAR (extrapolated) = 0.649 W/kg

SAR(1 g) = 0.257 W/kg; SAR(10 g) = 0.107 W/kg

Maximum value of SAR (measured) = 0.496 W/kg

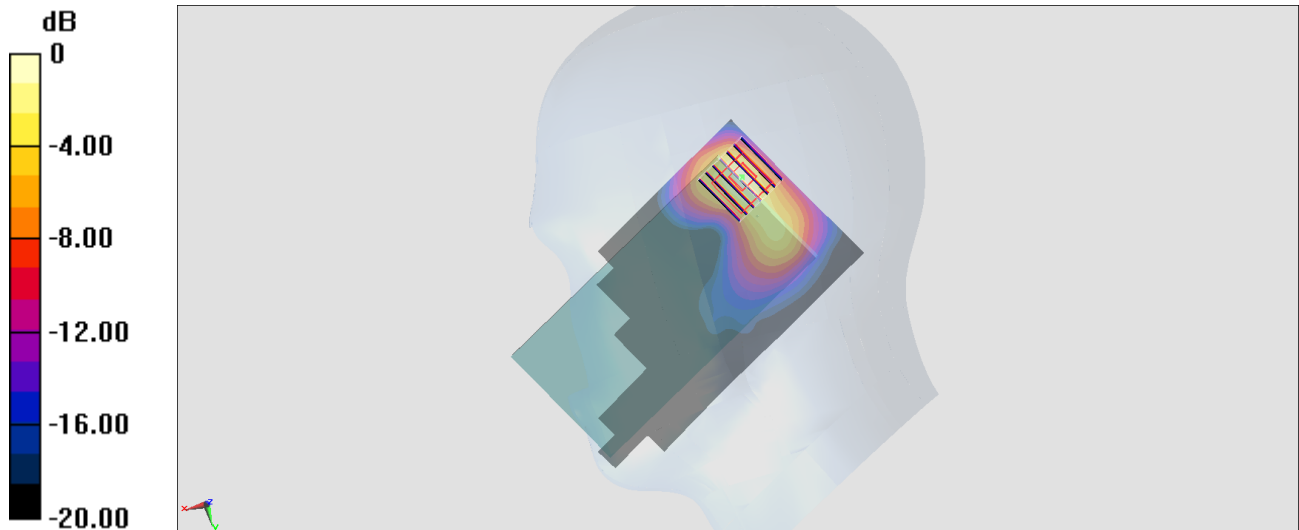

0 dB = 0.496 W/kg = -3.05 dBW/kg

#09_WLAN5GHz_802.11n-HT40 MCS0_Right Cheek_Ch62

Communication System: 802.11n; Frequency: 5310 MHz; Duty Cycle: 1:1.065

Medium: HSL_5G_181109 Medium parameters used: $f = 5310$ MHz; $\sigma = 4.805$ S/m; $\epsilon_r = 36.755$; $\rho = 1000$ kg/m³

Ambient Temperature : 23.1 °C ; Liquid Temperature : 22.1 °C

DASY5 Configuration:

- Probe: EX3DV4 - SN3976; ConvF(5.56, 5.56, 5.56) ; Calibrated: 2018/1/23
- Sensor-Surface: 1.4mm (Mechanical Surface Detection)
- Electronics: DAE4 Sn1424; Calibrated: 2018/1/18
- Phantom: SAM_Left; Type: QD000P40CD; Serial: TP:1477
- Measurement SW: DASY52, Version 52.10 (1); SEMCAD X Version 14.6.11 (7439)

Area Scan (91x181x1): Interpolated grid: dx=1.000 mm, dy=1.000 mm

Maximum value of SAR (interpolated) = 0.478 W/kg

Zoom Scan (8x8x7)/Cube 0: Measurement grid: dx=4mm, dy=4mm, dz=1.4mm

Reference Value = 6.298 V/m; Power Drift = -0.16 dB

Peak SAR (extrapolated) = 0.753 W/kg

SAR(1 g) = 0.192 W/kg; SAR(10 g) = 0.067 W/kg

Maximum value of SAR (measured) = 0.448 W/kg

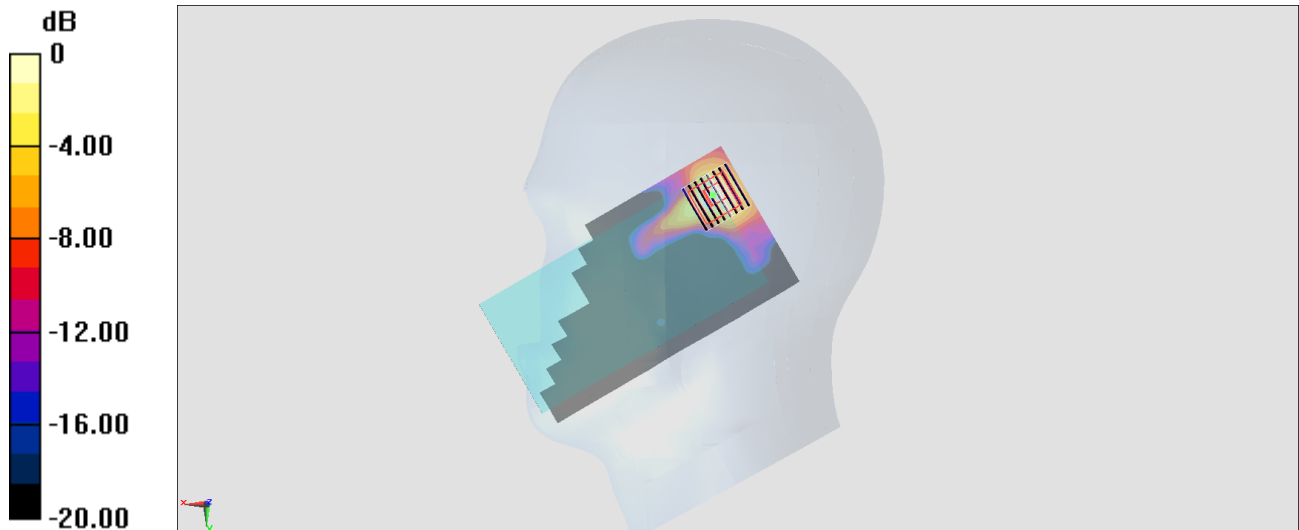

0 dB = 0.448 W/kg = -3.49 dBW/kg

#10_WLAN5GHz_802.11n-HT40 MCS0_Right Tilted_Ch110

Communication System: 802.11n; Frequency: 5550 MHz; Duty Cycle: 1:1.065

Medium: HSL_5G_181109 Medium parameters used: $f = 5550$ MHz; $\sigma = 5.051$ S/m; $\epsilon_r = 36.417$; $\rho = 1000$ kg/m³

Ambient Temperature : 23.1 °C ; Liquid Temperature : 22.1 °C

DASY5 Configuration:

- Probe: EX3DV4 - SN3976; ConvF(4.97, 4.97, 4.97) ; Calibrated: 2018/1/23
- Sensor-Surface: 1.4mm (Mechanical Surface Detection)
- Electronics: DAE4 Sn1424; Calibrated: 2018/1/18
- Phantom: SAM_Left; Type: QD000P40CD; Serial: TP:1477
- Measurement SW: DASY52, Version 52.10 (1); SEMCAD X Version 14.6.11 (7439)

Area Scan (101x101x1): Interpolated grid: dx=1.000 mm, dy=1.000 mm

Maximum value of SAR (interpolated) = 0.699 W/kg

Zoom Scan (8x8x7)/Cube 0: Measurement grid: dx=4mm, dy=4mm, dz=1.4mm

Reference Value = 8.044 V/m; Power Drift = 0.12 dB

Peak SAR (extrapolated) = 1.32 W/kg

SAR(1 g) = 0.309 W/kg; SAR(10 g) = 0.102 W/kg

Maximum value of SAR (measured) = 0.746 W/kg

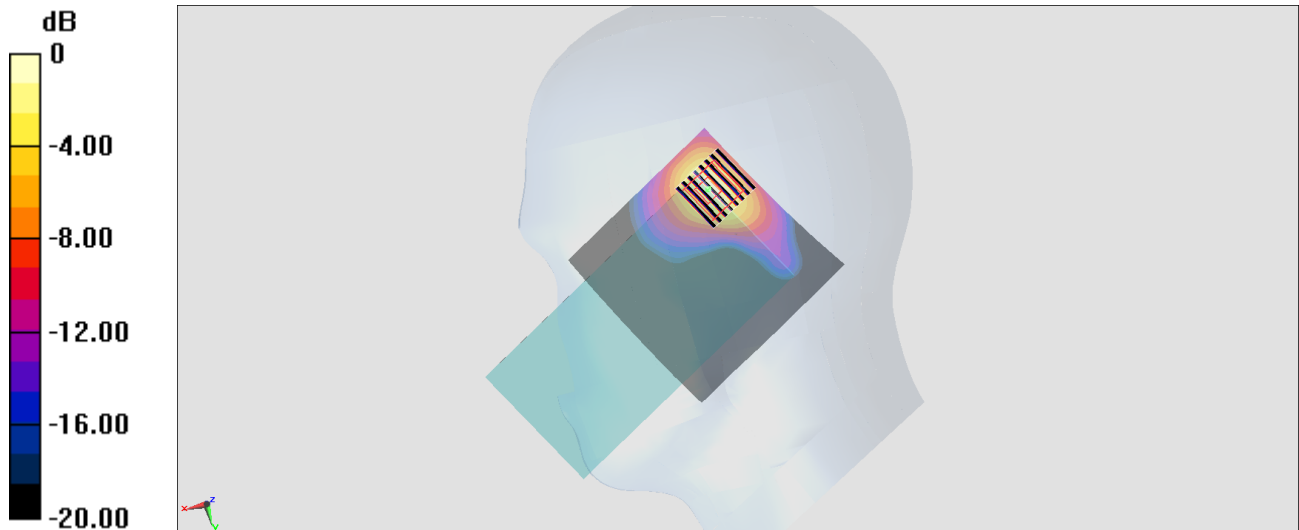

0 dB = 0.746 W/kg = -1.27 dBW/kg

#11_WLAN5GHz_802.11n-HT40 MCS0_Right Tilted_Ch151

Communication System: 802.11n; Frequency: 5755 MHz; Duty Cycle: 1:1.065

Medium: HSL_5G_181109 Medium parameters used: $f = 5755$ MHz; $\sigma = 5.266$ S/m; $\epsilon_r = 36.119$; $\rho = 1000$ kg/m³

Ambient Temperature : 23.1 °C ; Liquid Temperature : 22.1 °C

DASY5 Configuration:

- Probe: EX3DV4 - SN3976; ConvF(5.04, 5.04, 5.04) ; Calibrated: 2018/1/23
- Sensor-Surface: 1.4mm (Mechanical Surface Detection)
- Electronics: DAE4 Sn1424; Calibrated: 2018/1/18
- Phantom: SAM_Left; Type: QD000P40CD; Serial: TP:1477
- Measurement SW: DASY52, Version 52.10 (1); SEMCAD X Version 14.6.11 (7439)

Area Scan (101x101x1): Interpolated grid: dx=1.000 mm, dy=1.000 mm

Maximum value of SAR (interpolated) = 0.428 W/kg

Zoom Scan (9x9x7)/Cube 0: Measurement grid: dx=4mm, dy=4mm, dz=1.4mm

Reference Value = 5.249 V/m; Power Drift = -0.11 dB

Peak SAR (extrapolated) = 1.21 W/kg

SAR(1 g) = 0.193 W/kg; SAR(10 g) = 0.060 W/kg

Maximum value of SAR (measured) = 0.482 W/kg

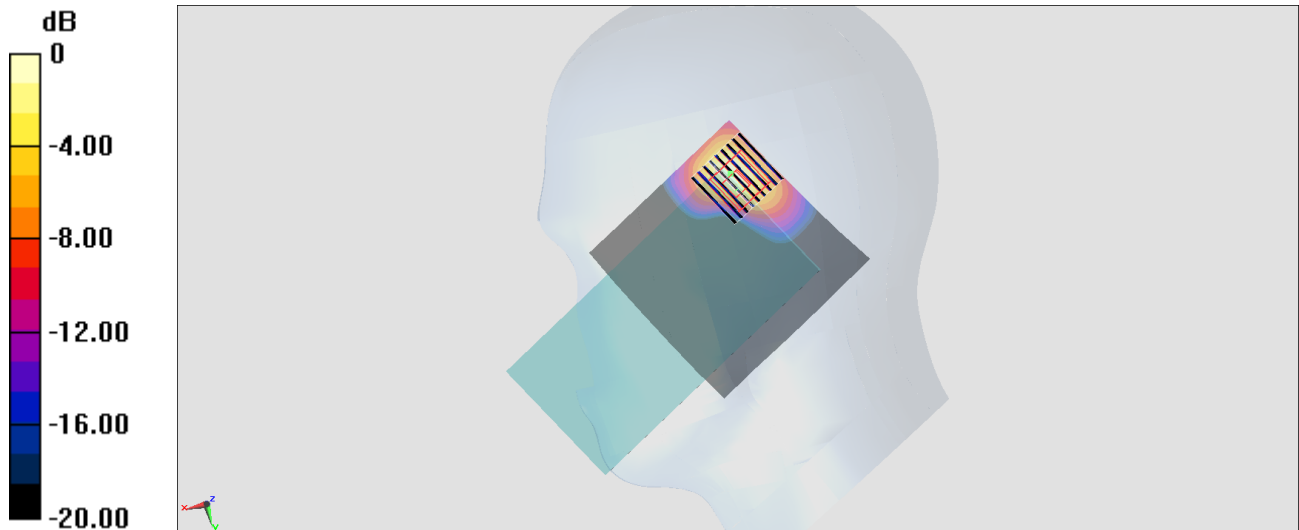

0 dB = 0.482 W/kg = -3.17 dBW/kg

#12_GSM850_GPRS (1 Tx slot)_Left Side_10mm_Ch251

Communication System: GSM850; Frequency: 848.8 MHz; Duty Cycle: 1:8.3

Medium: MSL_850_181105 Medium parameters used: $f = 849$ MHz; $\sigma = 0.992$ S/m; $\epsilon_r = 57.715$; $\rho = 1000$ kg/m³

Ambient Temperature : 23.5 °C ; Liquid Temperature : 22.5 °C

DASY5 Configuration:

- Probe: EX3DV4 - SN3976; ConvF(10.08, 10.08, 10.08) ; Calibrated: 2018/1/23
- Sensor-Surface: 1.4mm (Mechanical Surface Detection)
- Electronics: DAE4 Sn1424; Calibrated: 2018/1/18
- Phantom: SAM_Left; Type: QD000P40CD; Serial: TP:1477
- Measurement SW: DASY52, Version 52.10 (1); SEMCAD X Version 14.6.11 (7439)

Area Scan (41x121x1): Interpolated grid: dx=1.500 mm, dy=1.500 mm

Maximum value of SAR (interpolated) = 0.700 W/kg

Zoom Scan (5x5x7)/Cube 0: Measurement grid: dx=8mm, dy=8mm, dz=5mm

Reference Value = 27.28 V/m; Power Drift = 0.03 dB

Peak SAR (extrapolated) = 0.824 W/kg

SAR(1 g) = 0.539 W/kg; SAR(10 g) = 0.370 W/kg

Maximum value of SAR (measured) = 0.716 W/kg

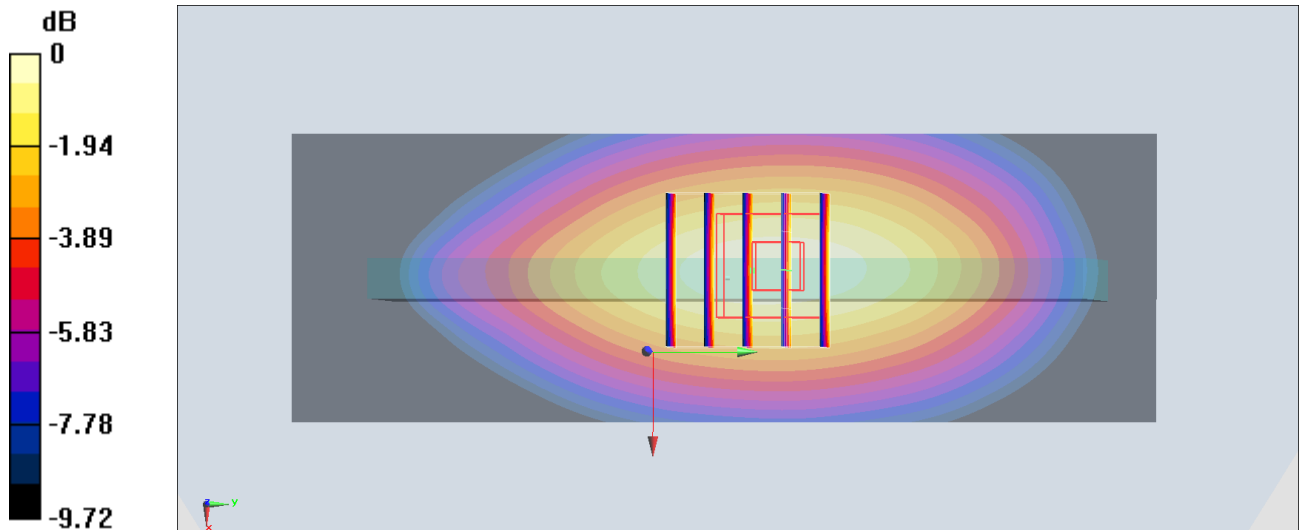

0 dB = 0.716 W/kg = -1.45 dBW/kg

#13_GSM1900_GPRS (3 Tx slots)_Bottom Side_10mm_Ch512

Communication System: PCS; Frequency: 1850.2 MHz; Duty Cycle: 1:2.77

Medium: MSL_1900_181112 Medium parameters used: $f = 1850.2$ MHz; $\sigma = 1.506$ S/m; $\epsilon_r = 51.891$; $\rho = 1000$ kg/m³

Ambient Temperature : 23.5 °C ; Liquid Temperature : 22.5 °C

DASY5 Configuration:

- Probe: EX3DV4 - SN3976; ConvF(8.09, 8.09, 8.09) ; Calibrated: 2018/1/23
- Sensor-Surface: 1.4mm (Mechanical Surface Detection)
- Electronics: DAE4 Sn1424; Calibrated: 2018/1/18
- Phantom: SAM_Left; Type: QD000P40CD; Serial: TP:1477
- Measurement SW: DASY52, Version 52.10 (1); SEMCAD X Version 14.6.11 (7439)

Area Scan (31x71x1): Interpolated grid: dx=1.500 mm, dy=1.500 mm

Maximum value of SAR (interpolated) = 1.28 W/kg

Zoom Scan (5x5x7)/Cube 0: Measurement grid: dx=8mm, dy=8mm, dz=5mm

Reference Value = 36.76 V/m; Power Drift = 0.11 dB

Peak SAR (extrapolated) = 1.54 W/kg

SAR(1 g) = 0.834 W/kg; SAR(10 g) = 0.432 W/kg

Maximum value of SAR (measured) = 1.29 W/kg

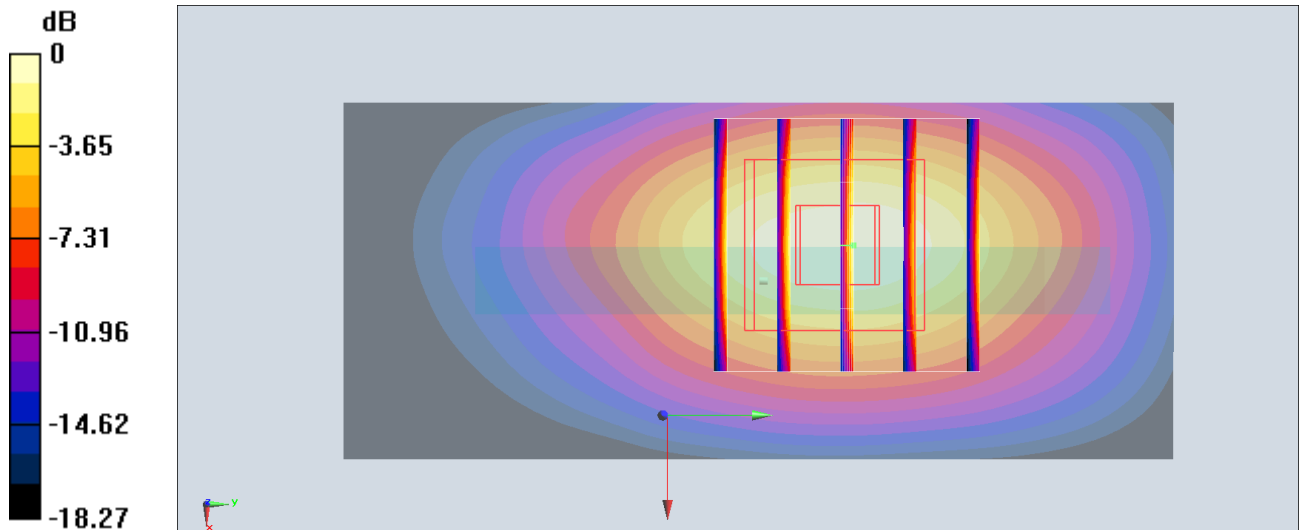

0 dB = 1.29 W/kg = 1.11 dBW/kg

#14_WCDMA II_RMC 12.2Kbps_Bottom Side_10mm_Ch9262

Communication System: WCDMA; Frequency: 1852.4 MHz; Duty Cycle: 1:1

Medium: MSL_1900_181108 Medium parameters used: $f = 1852.4$ MHz; $\sigma = 1.461$ S/m; $\epsilon_r = 52.377$; $\rho = 1000$ kg/m³

Ambient Temperature : 23.4 °C ; Liquid Temperature : 22.4 °C

DASY5 Configuration:

- Probe: EX3DV4 - SN3976; ConvF(8.09, 8.09, 8.09) ; Calibrated: 2018/1/23
- Sensor-Surface: 1.4mm (Mechanical Surface Detection)
- Electronics: DAE4 Sn1424; Calibrated: 2018/1/18
- Phantom: SAM_Right; Type: SAM; Serial: TP:1479
- Measurement SW: DASY52, Version 52.10 (1); SEMCAD X Version 14.6.11 (7439)

Area Scan (31x71x1): Interpolated grid: dx=1.500 mm, dy=1.500 mm

Maximum value of SAR (interpolated) = 1.78 W/kg

Zoom Scan (5x5x7)/Cube 0: Measurement grid: dx=8mm, dy=8mm, dz=5mm

Reference Value = 34.13 V/m; Power Drift = 0.14 dB

Peak SAR (extrapolated) = 2.11 W/kg

SAR(1 g) = 1.17 W/kg; SAR(10 g) = 0.614 W/kg

Maximum value of SAR (measured) = 1.78 W/kg

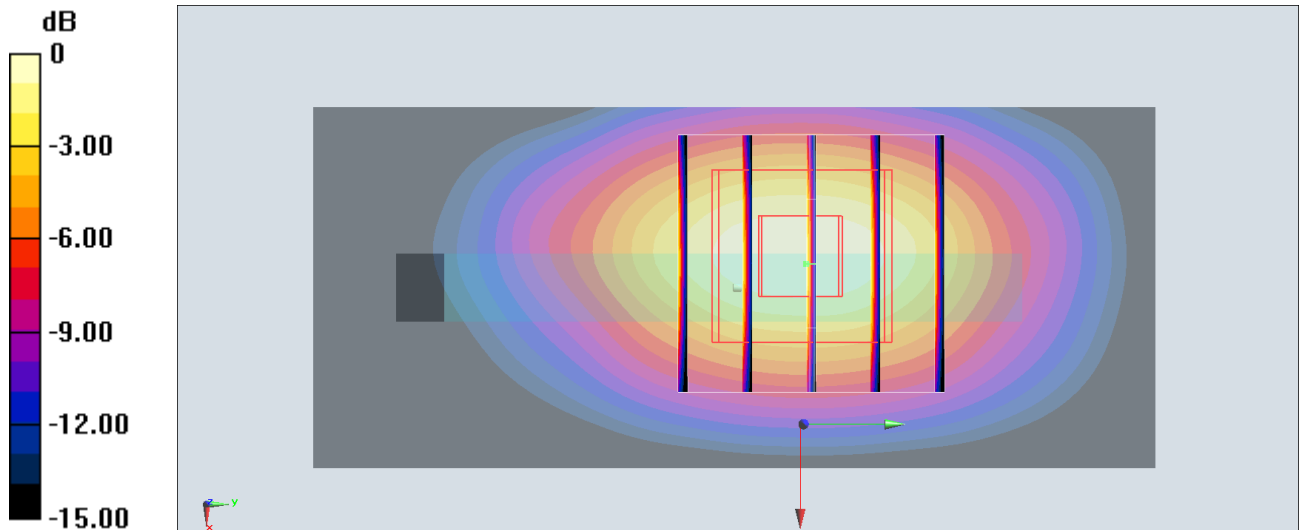

0 dB = 1.78 W/kg = 2.50 dBW/kg

#15_WCDMA V_RMC 12.2Kbps_Left Side_10mm_Ch4182

Communication System: WCDMA; Frequency: 836.4 MHz; Duty Cycle: 1:1

Medium: MSL_850_181105 Medium parameters used : $f = 836.4$ MHz; $\sigma = 0.978$ S/m; $\epsilon_r = 57.832$; $\rho = 1000$ kg/m³

Ambient Temperature : 23.5 °C ; Liquid Temperature : 22.5 °C

DASY5 Configuration:

- Probe: EX3DV4 - SN3976; ConvF(10.08, 10.08, 10.08) ; Calibrated: 2018/1/23
- Sensor-Surface: 1.4mm (Mechanical Surface Detection)
- Electronics: DAE4 Sn1424; Calibrated: 2018/1/18
- Phantom: SAM_Left; Type: QD000P40CD; Serial: TP:1477
- Measurement SW: DASY52, Version 52.10 (1); SEMCAD X Version 14.6.11 (7439)

Area Scan (41x121x1): Interpolated grid: dx=1.500 mm, dy=1.500 mm

Maximum value of SAR (interpolated) = 0.769 W/kg

Zoom Scan (5x5x7)/Cube 0: Measurement grid: dx=8mm, dy=8mm, dz=5mm

Reference Value = 28.89 V/m; Power Drift = 0.01 dB

Peak SAR (extrapolated) = 0.877 W/kg

SAR(1 g) = 0.586 W/kg; SAR(10 g) = 0.403 W/kg

Maximum value of SAR (measured) = 0.773 W/kg

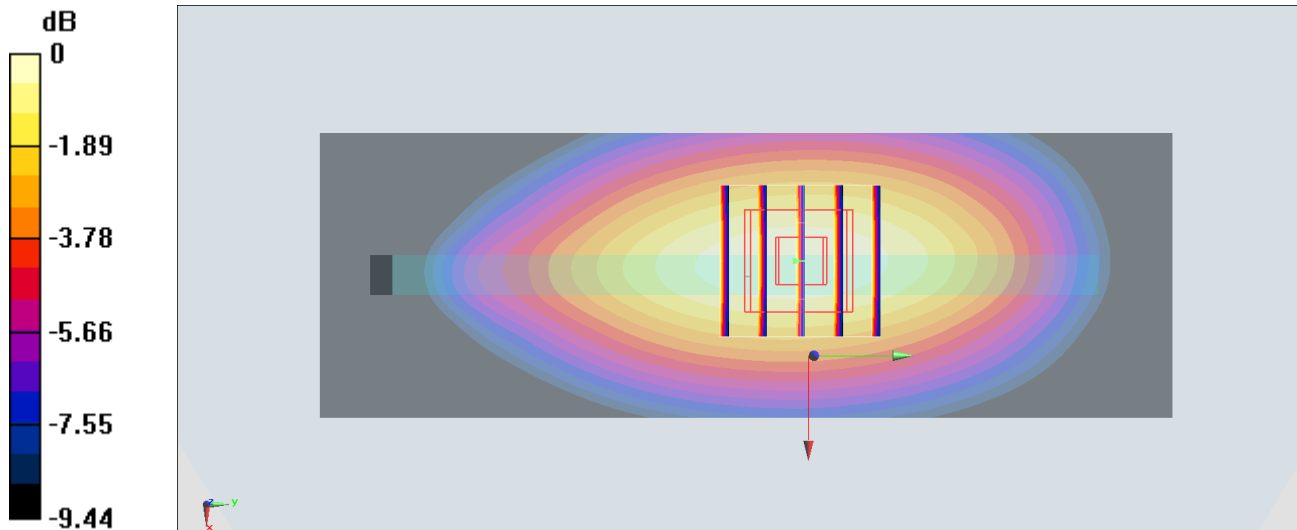

0 dB = 0.773 W/kg = -1.12 dBW/kg

#16_LTE Band 5_10M_QPSK_1_25_Left Side_10mm_Ch20525

Communication System: LTE; Frequency: 836.5 MHz; Duty Cycle: 1:1

Medium: MSL_850_181105 Medium parameters used : $f = 836.5$ MHz; $\sigma = 0.978$ S/m; $\epsilon_r = 57.831$; $\rho = 1000$ kg/m³

Ambient Temperature : 23.5 °C; Liquid Temperature : 22.5 °C

DASY5 Configuration:

- Probe: EX3DV4 - SN3976; ConvF(10.08, 10.08, 10.08) ; Calibrated: 2018/1/23
- Sensor-Surface: 1.4mm (Mechanical Surface Detection)
- Electronics: DAE4 Sn1424; Calibrated: 2018/1/18
- Phantom: SAM_Left; Type: QD000P40CD; Serial: TP:1477
- Measurement SW: DASY52, Version 52.10 (1); SEMCAD X Version 14.6.11 (7439)

Area Scan (41x121x1): Interpolated grid: dx=1.500 mm, dy=1.500 mm

Maximum value of SAR (interpolated) = 0.567 W/kg

Zoom Scan (5x5x7)/Cube 0: Measurement grid: dx=8mm, dy=8mm, dz=5mm

Reference Value = 24.85 V/m; Power Drift = -0.01 dB

Peak SAR (extrapolated) = 0.646 W/kg

SAR(1 g) = 0.432 W/kg; SAR(10 g) = 0.298 W/kg

Maximum value of SAR (measured) = 0.569 W/kg

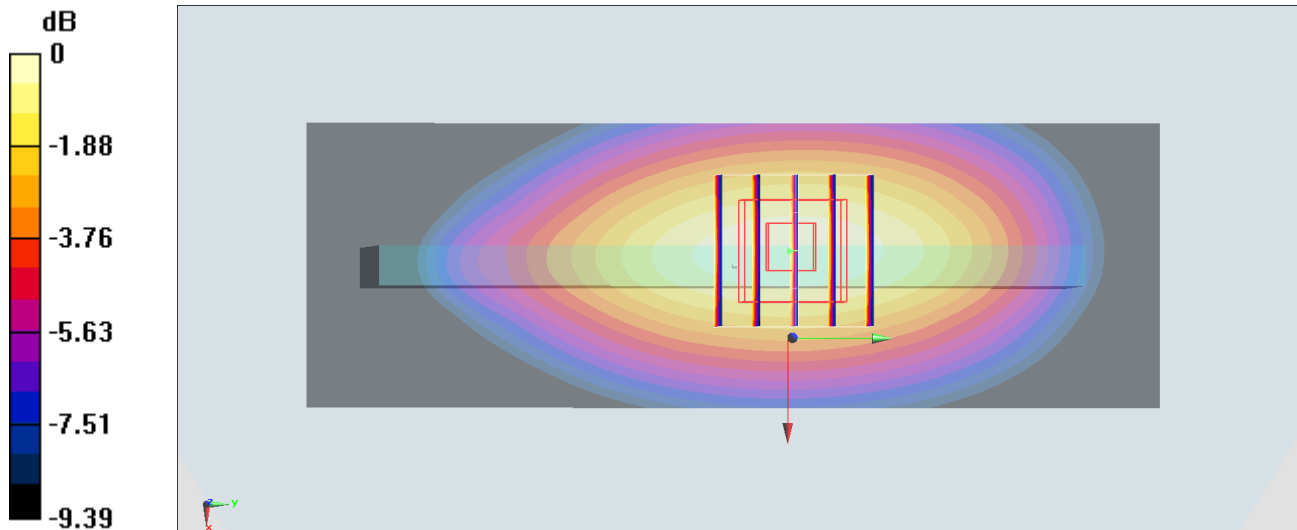

0 dB = 0.569 W/kg = -2.45 dBW/kg

#17_LTE Band 7_20M_QPSK_1_49_Back_10mm_Ch20850

Communication System: LTE; Frequency: 2510 MHz; Duty Cycle: 1:1

Medium: MSL_2600_181107 Medium parameters used: $f = 2510$ MHz; $\sigma = 2.094$ S/m; $\epsilon_r = 53.483$; $\rho = 1000$ kg/m³

Ambient Temperature : 23.6 °C ; Liquid Temperature : 22.6 °C

DASY5 Configuration:

- Probe: EX3DV4 - SN3976; ConvF(7.37, 7.37, 7.37) ; Calibrated: 2018/1/23
- Sensor-Surface: 1.4mm (Mechanical Surface Detection)
- Electronics: DAE4 Sn1424; Calibrated: 2018/1/18
- Phantom: SAM_Left; Type: QD000P40CD; Serial: TP:1477
- Measurement SW: DASY52, Version 52.10 (1); SEMCAD X Version 14.6.11 (7439)

Area Scan (81x61x1): Interpolated grid: dx=1.200 mm, dy=1.200 mm

Maximum value of SAR (interpolated) = 1.44 W/kg

Zoom Scan (7x7x7)/Cube 0: Measurement grid: dx=5mm, dy=5mm, dz=5mm

Reference Value = 25.71 V/m; Power Drift = -0.06 dB

Peak SAR (extrapolated) = 1.78 W/kg

SAR(1 g) = 0.969 W/kg; SAR(10 g) = 0.543 W/kg

Maximum value of SAR (measured) = 1.46 W/kg

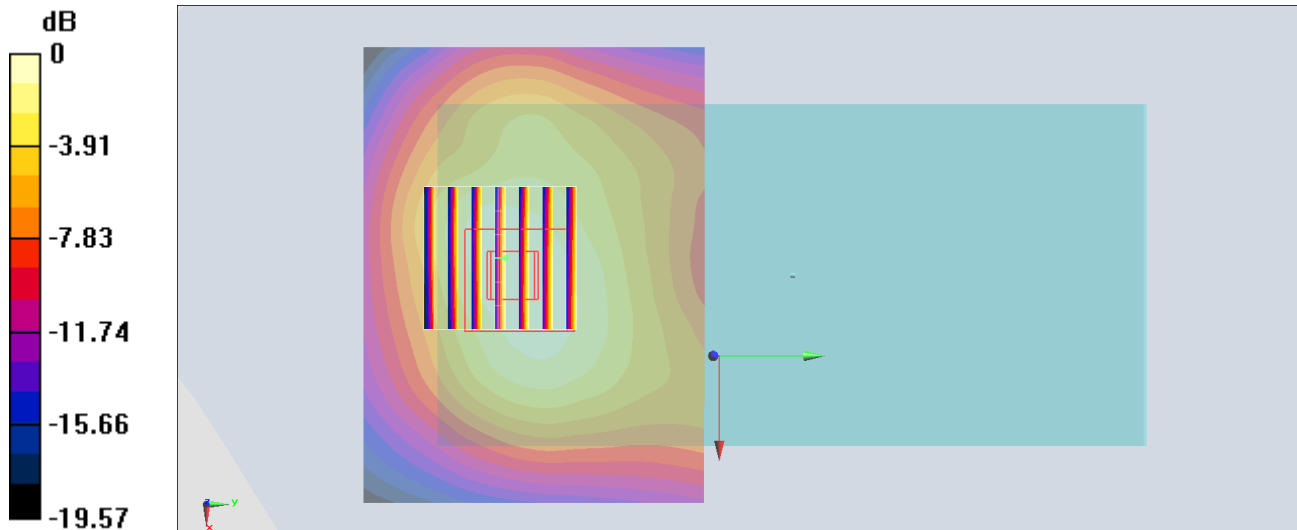

0 dB = 1.46 W/kg = 1.64 dBW/kg

#18_LTE Band 38_20M_QPSK_1_49_Back_10mm_Ch38000

Communication System: LTE; Frequency: 2595 MHz; Duty Cycle: 1:1.59

Medium: MSL_2600_181107 Medium parameters used: $f = 2595$ MHz; $\sigma = 2.211$ S/m; $\epsilon_r = 53.177$; $\rho = 1000$ kg/m³

Ambient Temperature : 23.6 °C ; Liquid Temperature : 22.6 °C

DASY5 Configuration:

- Probe: EX3DV4 - SN3976; ConvF(7.37, 7.37, 7.37) ; Calibrated: 2018/1/23
- Sensor-Surface: 1.4mm (Mechanical Surface Detection)
- Electronics: DAE4 Sn1424; Calibrated: 2018/1/18
- Phantom: SAM_Left; Type: QD000P40CD; Serial: TP:1477
- Measurement SW: DASY52, Version 52.10 (1); SEMCAD X Version 14.6.11 (7439)

Area Scan (81x141x1): Interpolated grid: dx=1.200 mm, dy=1.200 mm

Maximum value of SAR (interpolated) = 0.830 W/kg

Zoom Scan (7x7x7)/Cube 0: Measurement grid: dx=5mm, dy=5mm, dz=5mm

Reference Value = 18.13 V/m; Power Drift = -0.03 dB

Peak SAR (extrapolated) = 1.01 W/kg

SAR(1 g) = 0.538 W/kg; SAR(10 g) = 0.300 W/kg

Maximum value of SAR (measured) = 0.817 W/kg

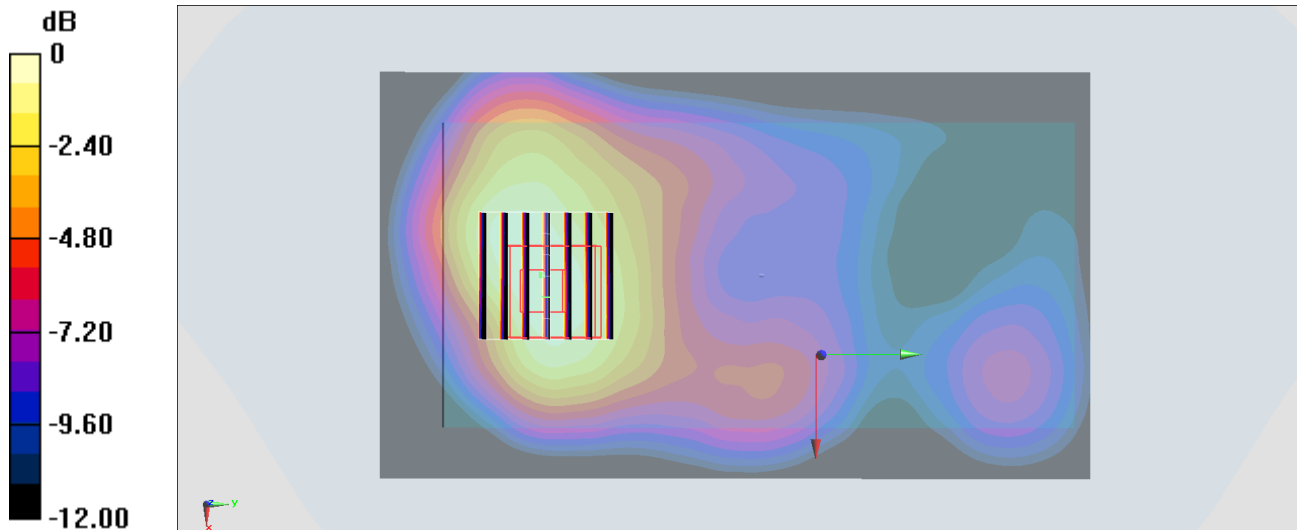

0 dB = 0.817 W/kg = -0.88 dBW/kg

#19_WLAN2.4GHz_802.11b 1Mbps_Back_10mm_Ch11

Communication System: 802.11b; Frequency: 2462 MHz; Duty Cycle: 1:1

Medium: MSL_2450_181107 Medium parameters used: $f = 2462$ MHz; $\sigma = 2.032$ S/m; $\epsilon_r = 53.645$; $\rho = 1000$ kg/m³

Ambient Temperature : 23.6 °C ; Liquid Temperature : 22.6 °C

DASY5 Configuration:

- Probe: EX3DV4 - SN3976; ConvF(7.8, 7.8, 7.8) ; Calibrated: 2018/1/23
- Sensor-Surface: 1.4mm (Mechanical Surface Detection)
- Electronics: DAE4 Sn1424; Calibrated: 2018/1/18
- Phantom: SAM_Left; Type: QD000P40CD; Serial: TP:1477
- Measurement SW: DASY52, Version 52.10 (1); SEMCAD X Version 14.6.11 (7439)

Area Scan (81x141x1): Interpolated grid: dx=1.200 mm, dy=1.200 mm

Maximum value of SAR (interpolated) = 0.192 W/kg

Zoom Scan (7x7x7)/Cube 0: Measurement grid: dx=5mm, dy=5mm, dz=5mm

Reference Value = 9.701 V/m; Power Drift = -0.06 dB

Peak SAR (extrapolated) = 0.228 W/kg

SAR(1 g) = 0.125 W/kg; SAR(10 g) = 0.072 W/kg

Maximum value of SAR (measured) = 0.187 W/kg

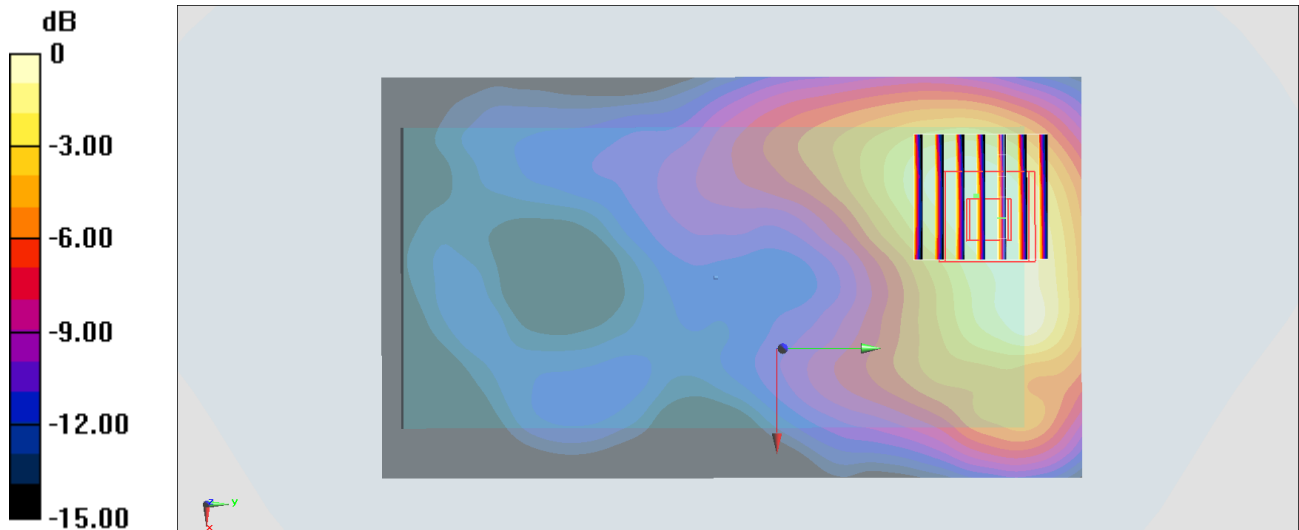

0 dB = 0.187 W/kg = -7.28 dBW/kg

#20_WLAN5GHz_802.11n-HT40 MCS0_Top Side_10mm_Ch46

Communication System: 802.11n; Frequency: 5230 MHz; Duty Cycle: 1:1.065

Medium: MSL_5G_181110 Medium parameters used: $f = 5230$ MHz; $\sigma = 5.344$ S/m; $\epsilon_r = 49.524$; $\rho = 1000$ kg/m³

Ambient Temperature : 23.5 °C ; Liquid Temperature : 22.5 °C

DASY5 Configuration:

- Probe: EX3DV4 - SN3976; ConvF(4.92, 4.92, 4.92) ; Calibrated: 2018/1/23
- Sensor-Surface: 1.4mm (Mechanical Surface Detection)
- Electronics: DAE4 Sn1424; Calibrated: 2018/1/18
- Phantom: SAM_Right; Type: SAM; Serial: TP:1479
- Measurement SW: DASY52, Version 52.10 (1); SEMCAD X Version 14.6.11 (7439)

Area Scan (41x101x1): Interpolated grid: dx=1.000 mm, dy=1.000 mm

Maximum value of SAR (interpolated) = 0.0466 W/kg

Zoom Scan (7x7x7)/Cube 0: Measurement grid: dx=4mm, dy=4mm, dz=1.4mm

Reference Value = 2.993 V/m; Power Drift = -0.06 dB

Peak SAR (extrapolated) = 0.0930 W/kg

SAR(1 g) = 0.020 W/kg; SAR(10 g) = 0.00728 W/kg

Maximum value of SAR (measured) = 0.0489 W/kg

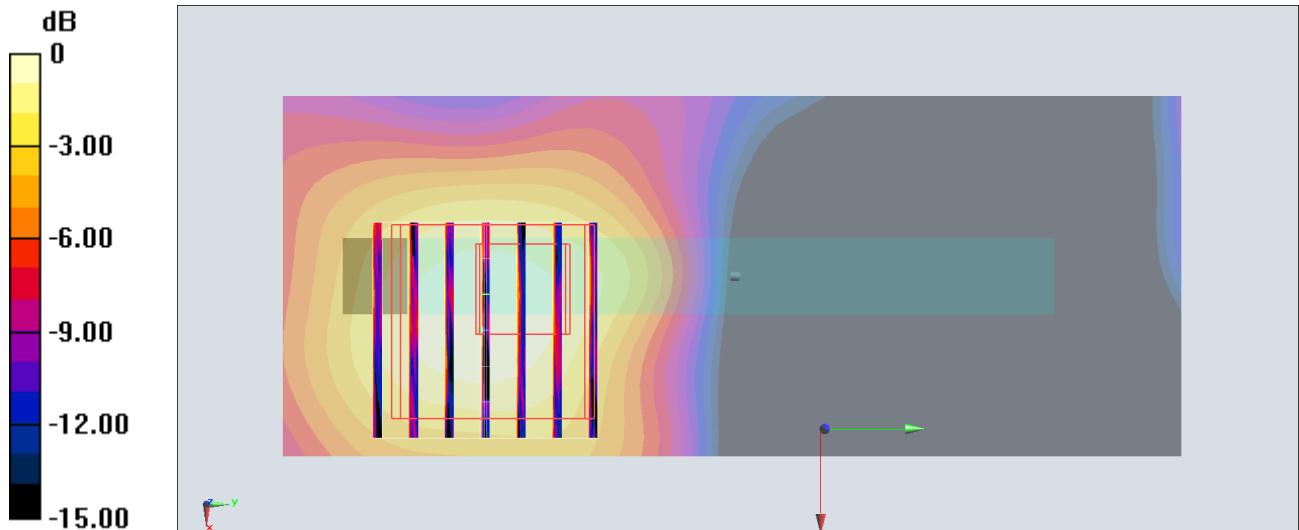

0 dB = 0.0489 W/kg = -13.11 dBW/kg

#21_WLAN5GHz_802.11n-HT40 MCS0_Top Side_10mm_Ch151

Communication System: 802.11n; Frequency: 5755 MHz; Duty Cycle: 1:1.065

Medium: MSL_5G_181110 Medium parameters used: $f = 5755$ MHz; $\sigma = 6.058$ S/m; $\epsilon_r = 48.585$; $\rho = 1000$ kg/m³

Ambient Temperature : 23.5 °C ; Liquid Temperature : 22.5 °C

DASY5 Configuration:

- Probe: EX3DV4 - SN3976; ConvF(4.46, 4.46, 4.46) ; Calibrated: 2018/1/23
- Sensor-Surface: 1.4mm (Mechanical Surface Detection)
- Electronics: DAE4 Sn1424; Calibrated: 2018/1/18
- Phantom: SAM_Right; Type: SAM; Serial: TP:1479
- Measurement SW: DASY52, Version 52.10 (1); SEMCAD X Version 14.6.11 (7439)

Area Scan (41x101x1): Interpolated grid: dx=1.000 mm, dy=1.000 mm

Maximum value of SAR (interpolated) = 0.0874 W/kg

Zoom Scan (7x7x7)/Cube 0: Measurement grid: dx=4mm, dy=4mm, dz=1.4mm

Reference Value = 4.115 V/m; Power Drift = -0.02 dB

Peak SAR (extrapolated) = 0.252 W/kg

SAR(1 g) = 0.035 W/kg; SAR(10 g) = 0.013 W/kg

Maximum value of SAR (measured) = 0.0906 W/kg

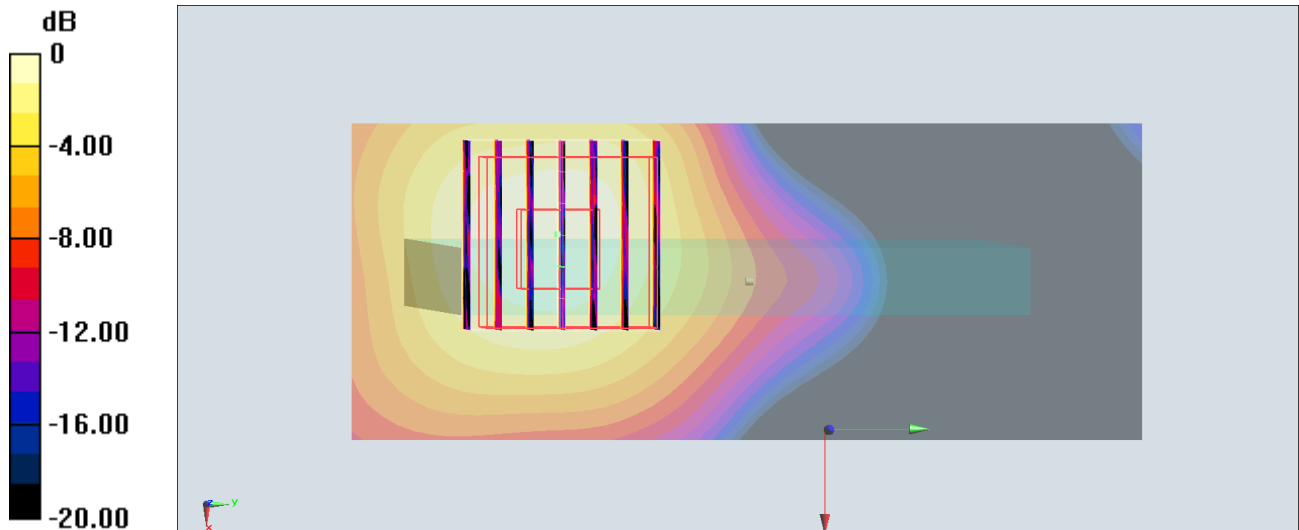

0 dB = 0.0906 W/kg = -10.43 dBW/kg

#22_GSM850_GPRS (1 Tx slot)_Back_15mm_Ch251

Communication System: GSM850; Frequency: 848.8 MHz; Duty Cycle: 1:8.3

Medium: MSL_850_181105 Medium parameters used: $f = 849$ MHz; $\sigma = 0.992$ S/m; $\epsilon_r = 57.715$; $\rho = 1000$ kg/m³

Ambient Temperature : 23.5 °C ; Liquid Temperature : 22.5 °C

DASY5 Configuration:

- Probe: EX3DV4 - SN3976; ConvF(10.08, 10.08, 10.08) ; Calibrated: 2018/1/23
- Sensor-Surface: 1.4mm (Mechanical Surface Detection)
- Electronics: DAE4 Sn1424; Calibrated: 2018/1/18
- Phantom: SAM_Left; Type: QD000P40CD; Serial: TP:1477
- Measurement SW: DASY52, Version 52.10 (1); SEMCAD X Version 14.6.11 (7439)

Area Scan (71x121x1): Interpolated grid: dx=1.500 mm, dy=1.500 mm

Maximum value of SAR (interpolated) = 0.492 W/kg

Zoom Scan (5x5x7)/Cube 0: Measurement grid: dx=8mm, dy=8mm, dz=5mm

Reference Value = 22.74 V/m; Power Drift = 0.02 dB

Peak SAR (extrapolated) = 0.539 W/kg

SAR(1 g) = 0.400 W/kg; SAR(10 g) = 0.311 W/kg

Maximum value of SAR (measured) = 0.487 W/kg

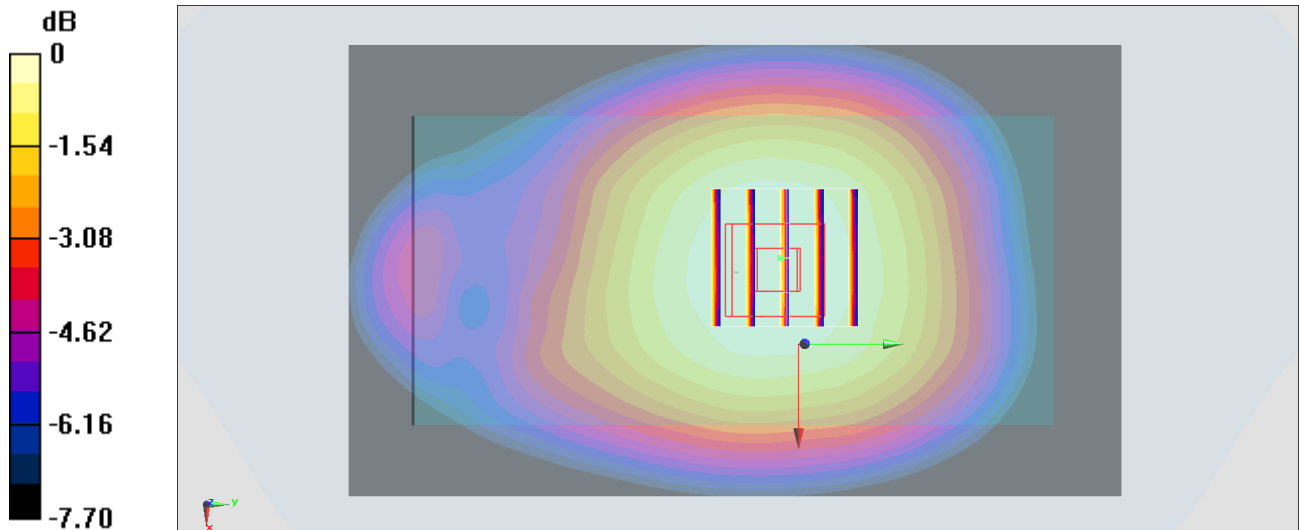

0 dB = 0.487 W/kg = -3.12 dBW/kg

#23_GSM1900_GPRS (1 Tx slots)_Back_15mm_Ch512

Communication System: PCS; Frequency: 1850.2 MHz; Duty Cycle: 1:8.3

Medium: MSL_1900_181112 Medium parameters used : $f = 1850.2$ MHz; $\sigma = 1.506$ S/m; $\epsilon_r = 51.891$; $\rho = 1000$ kg/m³

Ambient Temperature : 23.5 °C ; Liquid Temperature : 22.5 °C

DASY5 Configuration:

- Probe: EX3DV4 - SN3976; ConvF(8.09, 8.09, 8.09) ; Calibrated: 2018/1/23
- Sensor-Surface: 1.4mm (Mechanical Surface Detection)
- Electronics: DAE4 Sn1424; Calibrated: 2018/1/18
- Phantom: SAM_Left; Type: QD000P40CD; Serial: TP:1477
- Measurement SW: DASY52, Version 52.10 (1); SEMCAD X Version 14.6.11 (7439)

Area Scan (61x61x1): Interpolated grid: dx=1.500 mm, dy=1.500 mm

Maximum value of SAR (interpolated) = 0.562 W/kg

Zoom Scan (5x5x7)/Cube 0: Measurement grid: dx=8mm, dy=8mm, dz=5mm

Reference Value = 18.48 V/m; Power Drift = -0.01 dB

Peak SAR (extrapolated) = 0.677 W/kg

SAR(1 g) = 0.409 W/kg; SAR(10 g) = 0.234 W/kg

Maximum value of SAR (measured) = 0.589 W/kg

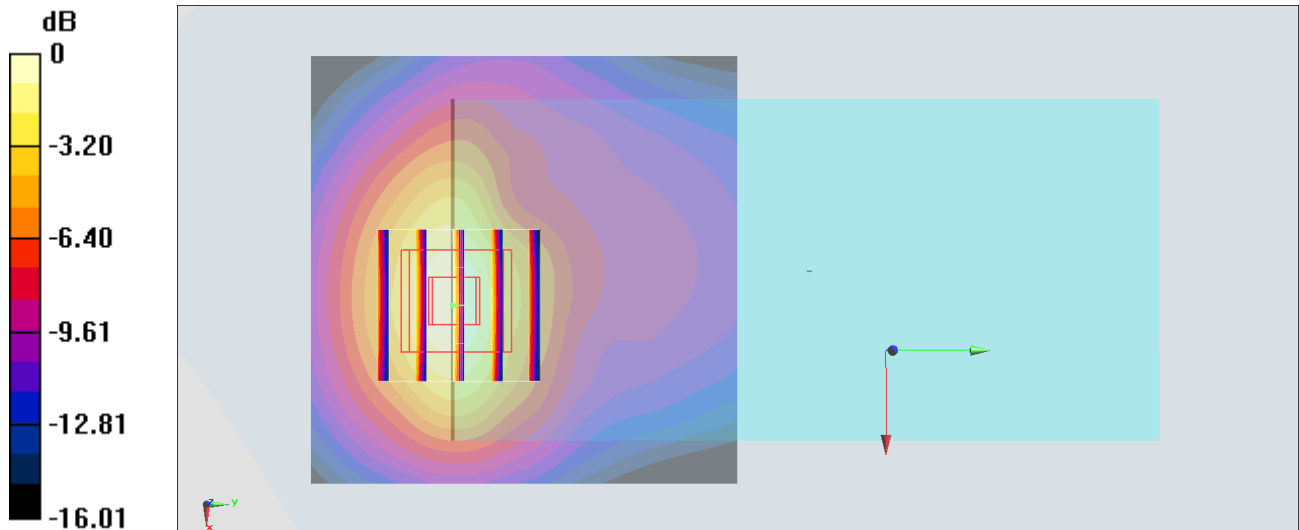

0 dB = 0.589 W/kg = -2.30 dBW/kg

#24_WCDMA II_RMC 12.2Kbps_Back_15mm_Ch9262

Communication System: WCDMA; Frequency: 1852.4 MHz; Duty Cycle: 1:1

Medium: MSL_1900_181112 Medium parameters used : $f = 1852.4$ MHz; $\sigma = 1.508$ S/m; $\epsilon_r = 51.884$; $\rho = 1000$ kg/m³

Ambient Temperature : 23.5 °C ; Liquid Temperature : 22.5 °C

DASY5 Configuration:

- Probe: EX3DV4 - SN3976; ConvF(8.09, 8.09, 8.09) ; Calibrated: 2018/1/23
- Sensor-Surface: 1.4mm (Mechanical Surface Detection)
- Electronics: DAE4 Sn1424; Calibrated: 2018/1/18
- Phantom: SAM_Left; Type: QD000P40CD; Serial: TP:1477
- Measurement SW: DASY52, Version 52.10 (1); SEMCAD X Version 14.6.11 (7439)

Area Scan (71x61x1): Interpolated grid: dx=1.500 mm, dy=1.500 mm

Maximum value of SAR (interpolated) = 1.58 W/kg

Zoom Scan (5x5x7)/Cube 0: Measurement grid: dx=8mm, dy=8mm, dz=5mm

Reference Value = 23.84 V/m; Power Drift = 0.03 dB

Peak SAR (extrapolated) = 1.89 W/kg

SAR(1 g) = 1.14 W/kg; SAR(10 g) = 0.657 W/kg

Maximum value of SAR (measured) = 1.64 W/kg

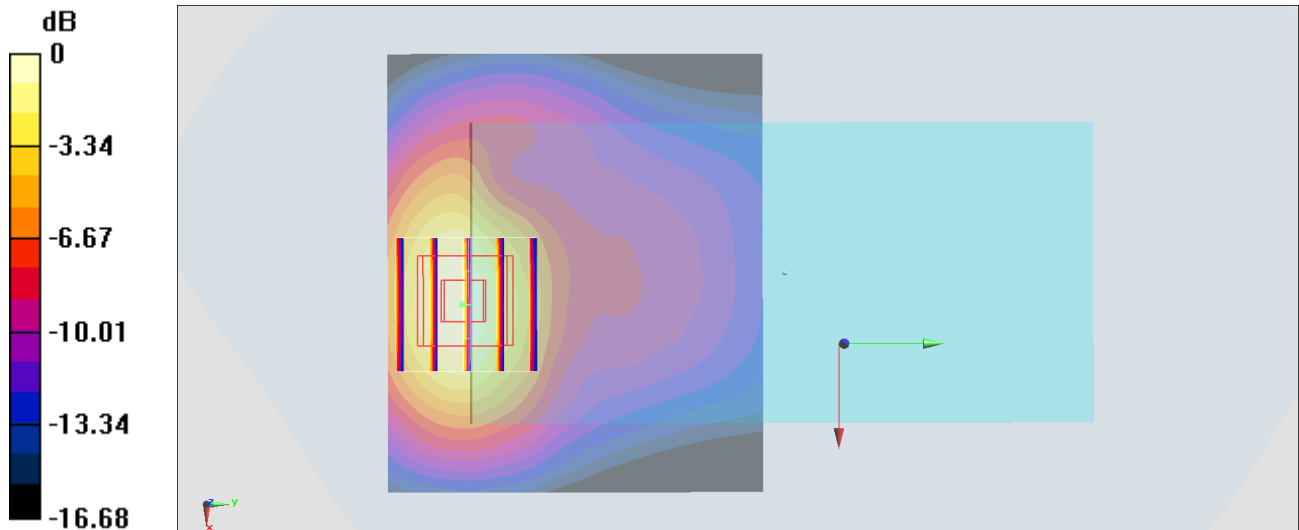

0 dB = 1.64 W/kg = 2.15 dBW/kg

#25_WCDMA V_RMC 12.2Kbps_Back_15mm_Ch4182

Communication System: WCDMA; Frequency: 836.4 MHz; Duty Cycle: 1:1

Medium: MSL_850_181105 Medium parameters used : $f = 836.4$ MHz; $\sigma = 0.978$ S/m; $\epsilon_r = 57.832$; $\rho = 1000$ kg/m³

Ambient Temperature : 23.5 °C ; Liquid Temperature : 22.5 °C

DASY5 Configuration:

- Probe: EX3DV4 - SN3976; ConvF(10.08, 10.08, 10.08) ; Calibrated: 2018/1/23
- Sensor-Surface: 1.4mm (Mechanical Surface Detection)
- Electronics: DAE4 Sn1424; Calibrated: 2018/1/18
- Phantom: SAM_Left; Type: QD000P40CD; Serial: TP:1477
- Measurement SW: DASY52, Version 52.10 (1); SEMCAD X Version 14.6.11 (7439)

Area Scan (71x121x1): Interpolated grid: dx=1.500 mm, dy=1.500 mm

Maximum value of SAR (interpolated) = 0.545 W/kg

Zoom Scan (5x5x7)/Cube 0: Measurement grid: dx=8mm, dy=8mm, dz=5mm

Reference Value = 24.29 V/m; Power Drift = 0.02 dB

Peak SAR (extrapolated) = 0.592 W/kg

SAR(1 g) = 0.451 W/kg; SAR(10 g) = 0.350 W/kg

Maximum value of SAR (measured) = 0.541 W/kg

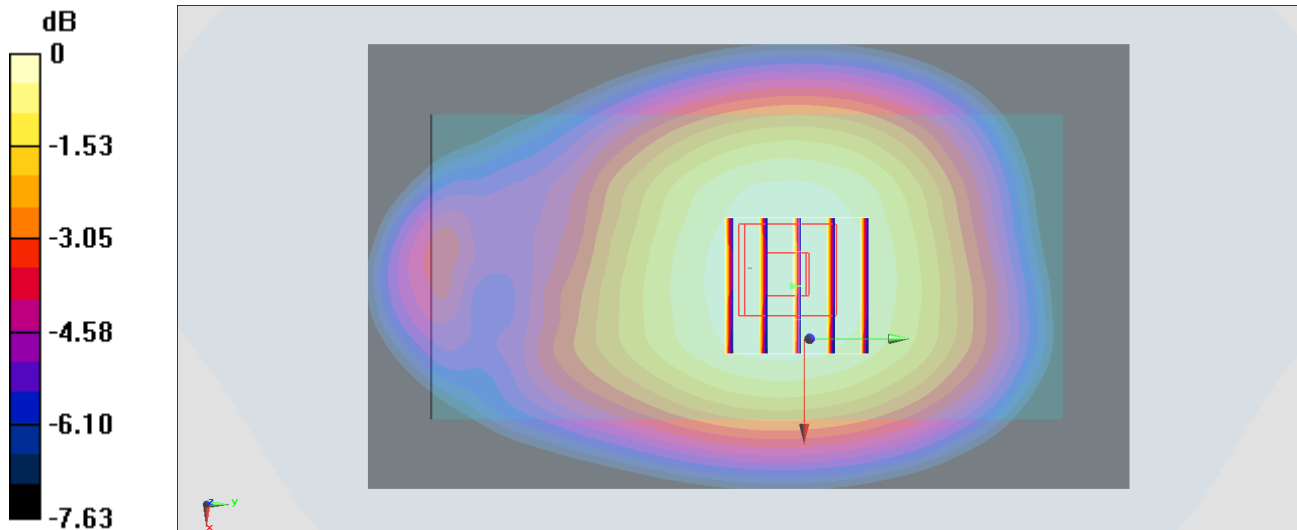

0 dB = 0.541 W/kg = -2.67 dBW/kg

#26_LTE Band 5_10M_QPSK_1_25_Back_15mm_Ch20525

Communication System: LTE; Frequency: 836.5 MHz; Duty Cycle: 1:1

Medium: MSL_850_181105 Medium parameters used: $f = 836.5$ MHz; $\sigma = 0.978$ S/m; $\epsilon_r = 57.831$; $\rho = 1000$ kg/m³

Ambient Temperature : 23.5 °C ; Liquid Temperature : 22.5 °C

DASY5 Configuration:

- Probe: EX3DV4 - SN3976; ConvF(10.08, 10.08, 10.08) ; Calibrated: 2018/1/23
- Sensor-Surface: 1.4mm (Mechanical Surface Detection)
- Electronics: DAE4 Sn1424; Calibrated: 2018/1/18
- Phantom: SAM_Left; Type: QD000P40CD; Serial: TP:1477
- Measurement SW: DASY52, Version 52.10 (1); SEMCAD X Version 14.6.11 (7439)

Area Scan (71x121x1): Interpolated grid: dx=1.500 mm, dy=1.500 mm

Maximum value of SAR (interpolated) = 0.442 W/kg

Zoom Scan (5x5x7)/Cube 0: Measurement grid: dx=8mm, dy=8mm, dz=5mm

Reference Value = 22.14 V/m; Power Drift = 0.01 dB

Peak SAR (extrapolated) = 0.483 W/kg

SAR(1 g) = 0.366 W/kg; SAR(10 g) = 0.284 W/kg

Maximum value of SAR (measured) = 0.441 W/kg

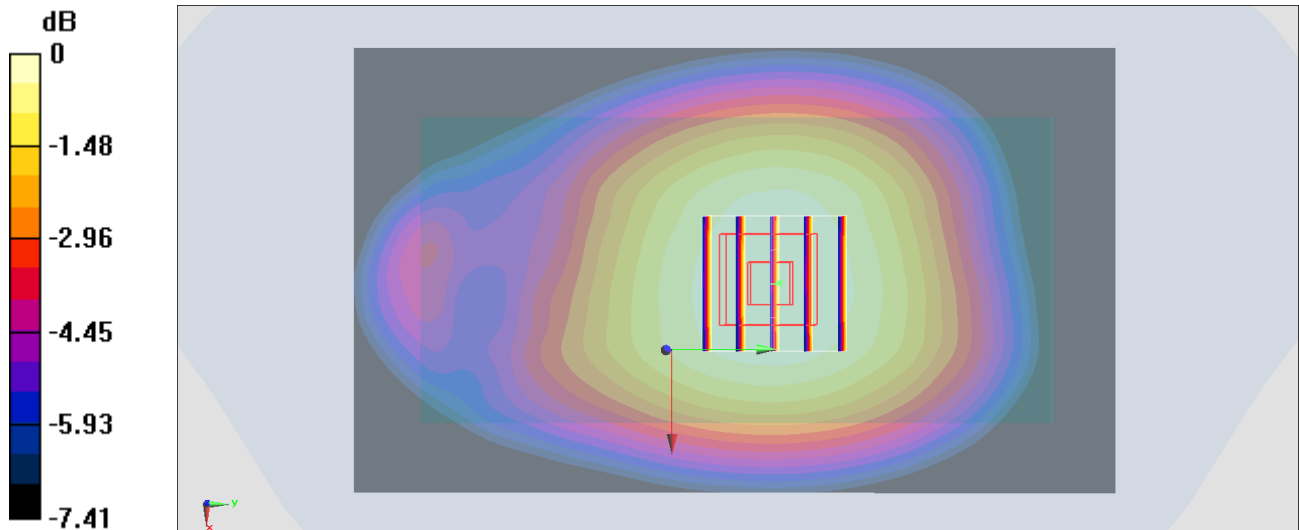

0 dB = 0.441 W/kg = -3.56 dBW/kg

#27_LTE Band 7_20M_QPSK_1_49_Back_15mm_Ch21350

Communication System: LTE; Frequency: 2560 MHz; Duty Cycle: 1:1

Medium: MSL_2600_181107 Medium parameters used: $f = 2560$ MHz; $\sigma = 2.162$ S/m; $\epsilon_r = 53.3$; $\rho = 1000$ kg/m³

Ambient Temperature : 23.6 °C ; Liquid Temperature : 22.6 °C

DASY5 Configuration:

- Probe: EX3DV4 - SN3976; ConvF(7.37, 7.37, 7.37) ; Calibrated: 2018/1/23
- Sensor-Surface: 1.4mm (Mechanical Surface Detection)
- Electronics: DAE4 Sn1424; Calibrated: 2018/1/18
- Phantom: SAM_Left; Type: QD000P40CD; Serial: TP:1477
- Measurement SW: DASY52, Version 52.10 (1); SEMCAD X Version 14.6.11 (7439)

Area Scan (81x81x1): Interpolated grid: dx=1.200 mm, dy=1.200 mm

Maximum value of SAR (interpolated) = 0.720 W/kg

Zoom Scan (7x7x7)/Cube 0: Measurement grid: dx=5mm, dy=5mm, dz=5mm

Reference Value = 19.21 V/m; Power Drift = -0.01 dB

Peak SAR (extrapolated) = 0.884 W/kg

SAR(1 g) = 0.483 W/kg; SAR(10 g) = 0.274 W/kg

Maximum value of SAR (measured) = 0.723 W/kg

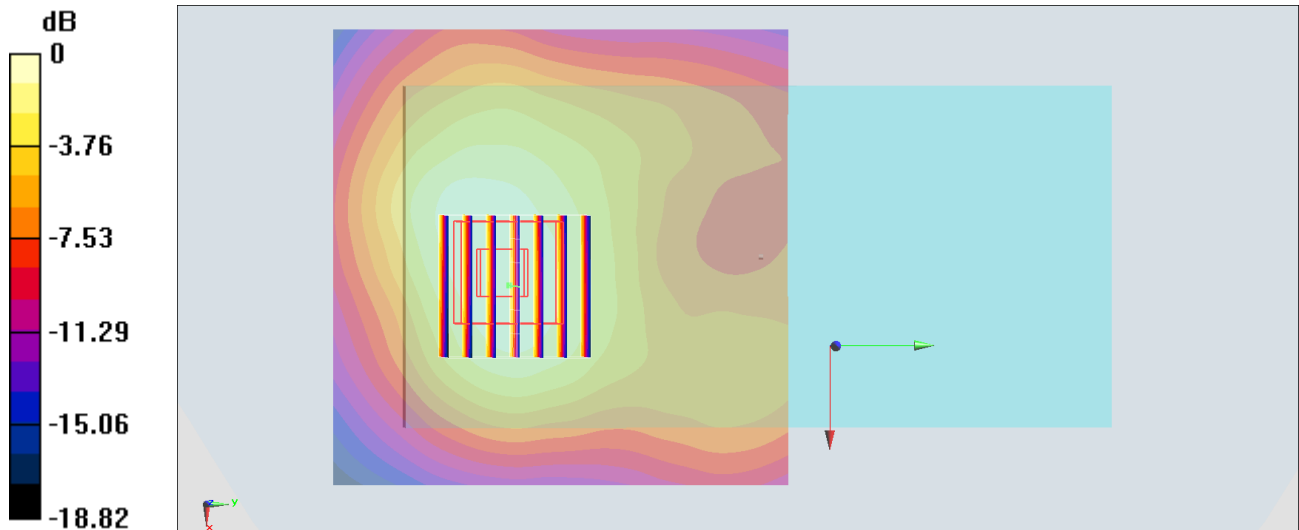

0 dB = 0.723 W/kg = -1.41 dBW/kg

#28_LTE Band 38_20M_QPSK_1_49_Back_15mm_Ch38000

Communication System: LTE; Frequency: 2595 MHz; Duty Cycle: 1:1.59

Medium: MSL_2600_181107 Medium parameters used: $f = 2595$ MHz; $\sigma = 2.211$ S/m; $\epsilon_r = 53.177$; $\rho = 1000$ kg/m³

Ambient Temperature : 23.6 °C; Liquid Temperature : 22.6 °C

DASY5 Configuration:

- Probe: EX3DV4 - SN3976; ConvF(7.37, 7.37, 7.37) ; Calibrated: 2018/1/23
- Sensor-Surface: 1.4mm (Mechanical Surface Detection)
- Electronics: DAE4 Sn1424; Calibrated: 2018/1/18
- Phantom: SAM_Left; Type: QD000P40CD; Serial: TP:1477
- Measurement SW: DASY52, Version 52.10 (1); SEMCAD X Version 14.6.11 (7439)

Area Scan (81x91x1): Interpolated grid: dx=1.200 mm, dy=1.200 mm

Maximum value of SAR (interpolated) = 0.434 W/kg

Zoom Scan (7x7x7)/Cube 0: Measurement grid: dx=5mm, dy=5mm, dz=5mm

Reference Value = 13.88 V/m; Power Drift = -0.06 dB

Peak SAR (extrapolated) = 0.530 W/kg

SAR(1 g) = 0.288 W/kg; SAR(10 g) = 0.163 W/kg

Maximum value of SAR (measured) = 0.434 W/kg

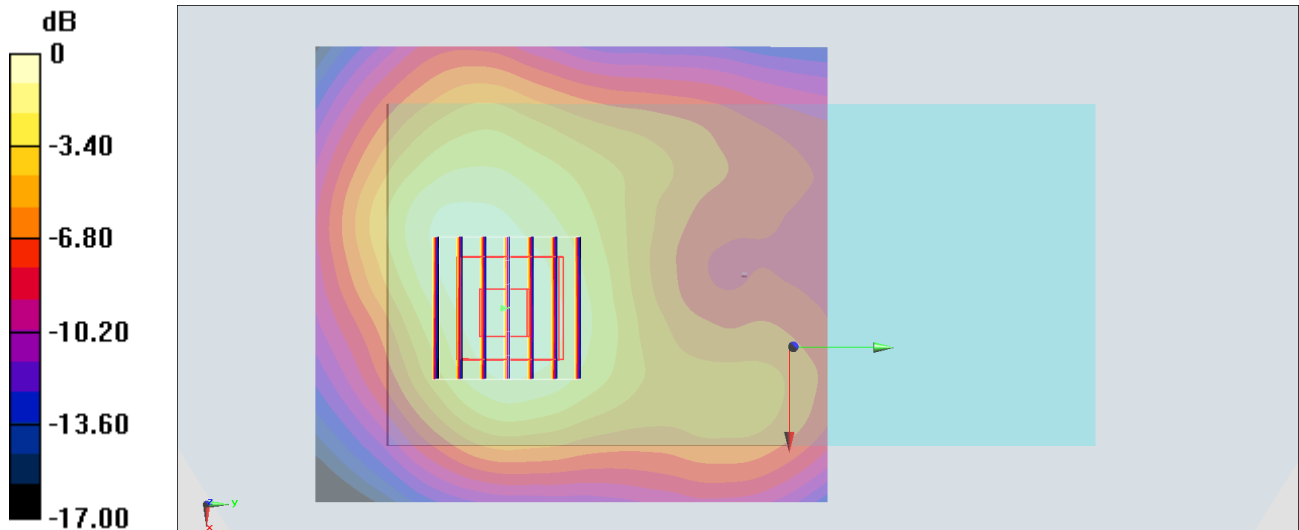

0 dB = 0.434 W/kg = -3.63 dBW/kg

#29_WLAN2.4GHz_802.11b 1Mbps_Back_15mm_Ch11

Communication System: 802.11b; Frequency: 2462 MHz; Duty Cycle: 1:1

Medium: MSL_2450_181107 Medium parameters used: $f = 2462$ MHz; $\sigma = 2.032$ S/m; $\epsilon_r = 53.645$; $\rho = 1000$ kg/m³

Ambient Temperature : 23.6 °C ; Liquid Temperature : 22.6 °C

DASY5 Configuration:

- Probe: EX3DV4 - SN3976; ConvF(7.8, 7.8, 7.8) ; Calibrated: 2018/1/23
- Sensor-Surface: 1.4mm (Mechanical Surface Detection)
- Electronics: DAE4 Sn1424; Calibrated: 2018/1/18
- Phantom: SAM_Left; Type: QD000P40CD; Serial: TP:1477
- Measurement SW: DASY52, Version 52.10 (1); SEMCAD X Version 14.6.11 (7439)

Area Scan (81x81x1): Interpolated grid: dx=1.200 mm, dy=1.200 mm

Maximum value of SAR (interpolated) = 0.107 W/kg

Zoom Scan (7x7x7)/Cube 0: Measurement grid: dx=5mm, dy=5mm, dz=5mm

Reference Value = 7.277 V/m; Power Drift = 0.04 dB

Peak SAR (extrapolated) = 0.147 W/kg

SAR(1 g) = 0.082 W/kg; SAR(10 g) = 0.047 W/kg

Maximum value of SAR (measured) = 0.120 W/kg

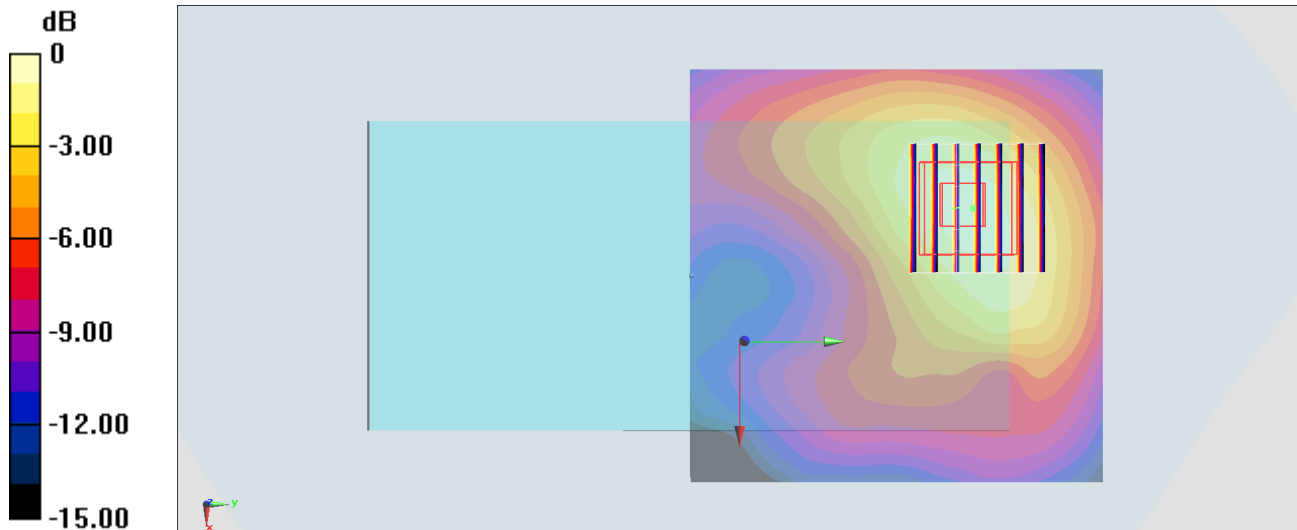

0 dB = 0.120 W/kg = -9.21 dBW/kg

#30_WLAN5GHz_802.11n-HT40 MCS0_Back_15mm_Ch62

Communication System: 802.11n; Frequency: 5310 MHz; Duty Cycle: 1:1.065

Medium: MSL_5G_181110 Medium parameters used: $f = 5310$ MHz; $\sigma = 5.452$ S/m; $\epsilon_r = 49.387$; $\rho = 1000$ kg/m³

Ambient Temperature : 23.5 °C ; Liquid Temperature : 22.5 °C

DASY5 Configuration:

- Probe: EX3DV4 - SN3976; ConvF(4.92, 4.92, 4.92) ; Calibrated: 2018/1/23
- Sensor-Surface: 1.4mm (Mechanical Surface Detection)
- Electronics: DAE4 Sn1424; Calibrated: 2018/1/18
- Phantom: SAM_Right; Type: SAM; Serial: TP:1479
- Measurement SW: DASY52, Version 52.10 (1); SEMCAD X Version 14.6.11 (7439)

Area Scan (91x91x1): Interpolated grid: dx=1.000 mm, dy=1.000 mm

Maximum value of SAR (interpolated) = 0.0406 W/kg

Zoom Scan (7x7x7)/Cube 0: Measurement grid: dx=4mm, dy=4mm, dz=1.4mm

Reference Value = 2.371 V/m; Power Drift = -0.19 dB

Peak SAR (extrapolated) = 0.156 W/kg

SAR(1 g) = 0.013 W/kg; SAR(10 g) = 0.00489 W/kg

Maximum value of SAR (measured) = 0.0337 W/kg

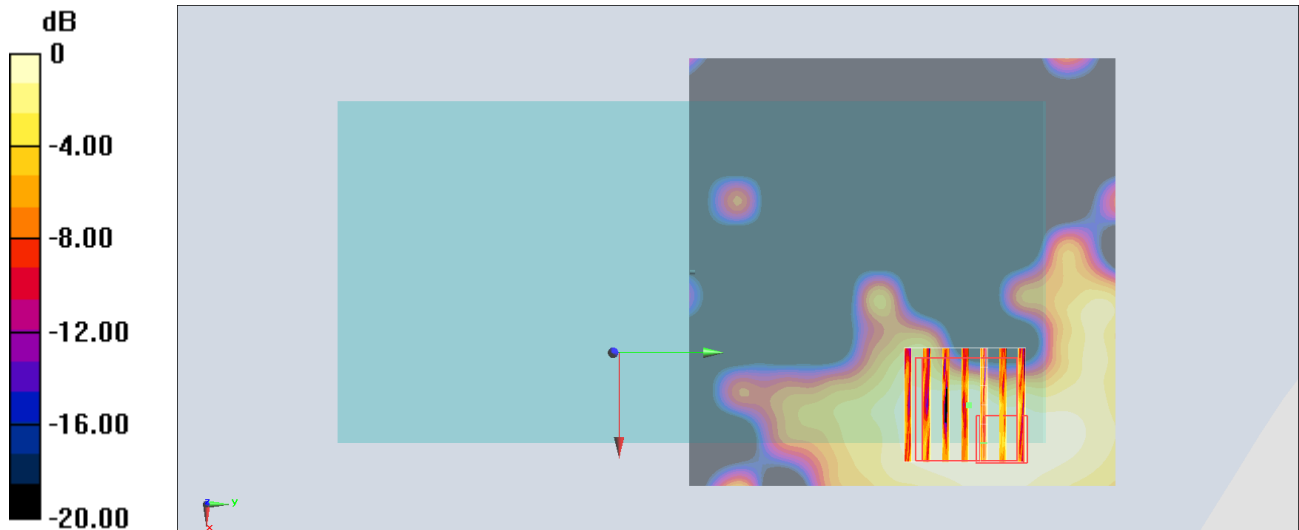

0 dB = 0.0337 W/kg = -14.72 dBW/kg

#31_WLAN5GHz_802.11n-HT40 MCS0_Back_15mm_Ch110

Communication System: 802.11n; Frequency: 5550 MHz; Duty Cycle: 1:1.065

Medium: MSL_5G_181110 Medium parameters used: $f = 5550$ MHz; $\sigma = 5.787$ S/m; $\epsilon_r = 49.004$; $\rho = 1000$ kg/m³

Ambient Temperature : 23.5 °C ; Liquid Temperature : 22.5 °C

DASY5 Configuration:

- Probe: EX3DV4 - SN3976; ConvF(4.28, 4.28, 4.28) ; Calibrated: 2018/1/23
- Sensor-Surface: 1.4mm (Mechanical Surface Detection)
- Electronics: DAE4 Sn1424; Calibrated: 2018/1/18
- Phantom: SAM_Right; Type: SAM; Serial: TP:1479
- Measurement SW: DASY52, Version 52.10 (1); SEMCAD X Version 14.6.11 (7439)

Area Scan (91x91x1): Interpolated grid: dx=1.000 mm, dy=1.000 mm

Maximum value of SAR (interpolated) = 0.0672 W/kg

Zoom Scan (7x7x7)/Cube 0: Measurement grid: dx=4mm, dy=4mm, dz=1.4mm

Reference Value = 3.731 V/m; Power Drift = 0.11 dB

Peak SAR (extrapolated) = 0.305 W/kg

SAR(1 g) = 0.026 W/kg; SAR(10 g) = 0.012 W/kg

Maximum value of SAR (measured) = 0.0687 W/kg

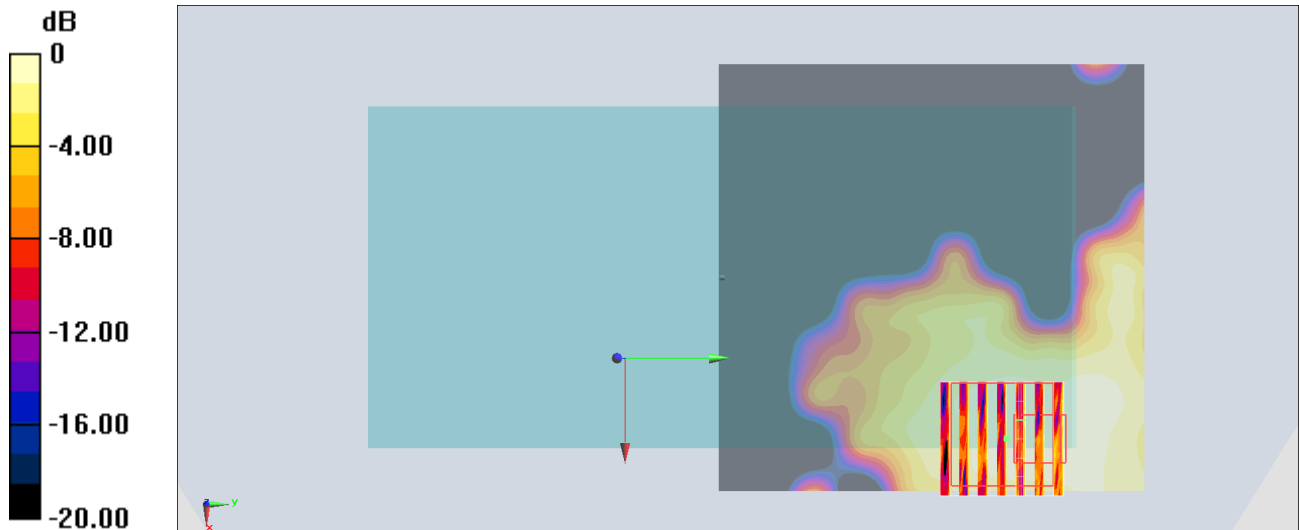

#32_WLAN5GHz_802.11n-HT40 MCS0_Back_15mm_Ch151

Communication System: 802.11n; Frequency: 5755 MHz; Duty Cycle: 1:1.065

Medium: MSL_5G_181110 Medium parameters used: $f = 5755$ MHz; $\sigma = 6.058$ S/m; $\epsilon_r = 48.585$; $\rho = 1000$ kg/m³

Ambient Temperature : 23.5 °C ; Liquid Temperature : 22.5 °C

DASY5 Configuration:

- Probe: EX3DV4 - SN3976; ConvF(4.46, 4.46, 4.46) ; Calibrated: 2018/1/23
- Sensor-Surface: 1.4mm (Mechanical Surface Detection)
- Electronics: DAE4 Sn1424; Calibrated: 2018/1/18
- Phantom: SAM_Right; Type: SAM; Serial: TP:1479
- Measurement SW: DASY52, Version 52.10 (1); SEMCAD X Version 14.6.11 (7439)

Area Scan (91x91x1): Interpolated grid: dx=1.000 mm, dy=1.000 mm

Maximum value of SAR (interpolated) = 0.0440 W/kg

Zoom Scan (7x7x7)/Cube 0: Measurement grid: dx=4mm, dy=4mm, dz=1.4mm

Reference Value = 2.826 V/m; Power Drift = 0.14 dB

Peak SAR (extrapolated) = 0.244 W/kg

SAR(1 g) = 0.014 W/kg; SAR(10 g) = 0.00694 W/kg

Maximum value of SAR (measured) = 0.0444 W/kg

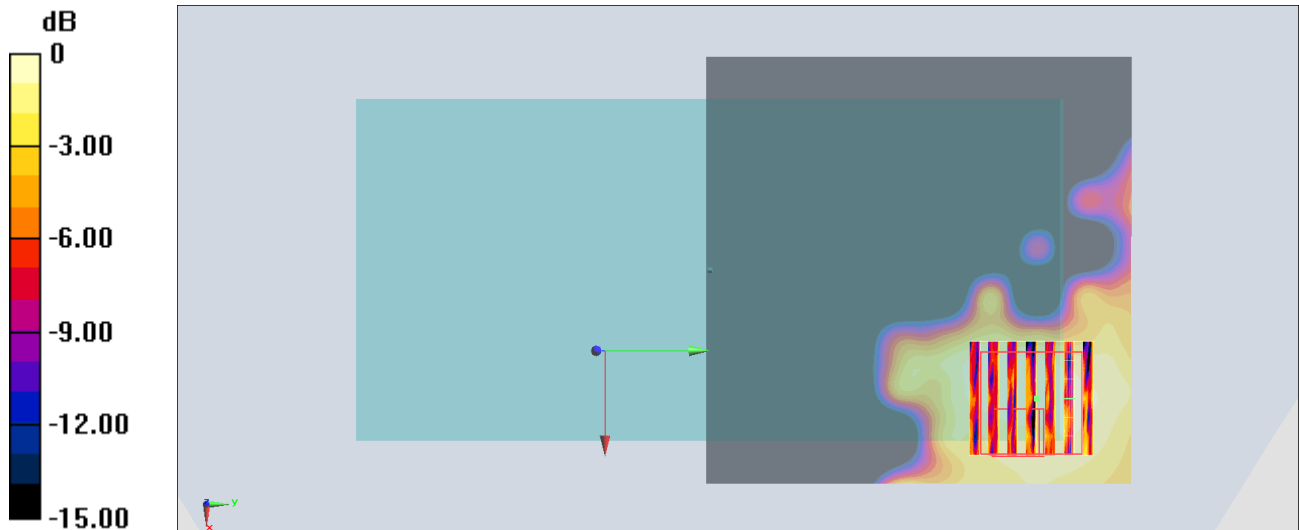

0 dB = 0.0444 W/kg = -13.53 dBW/kg