

FCC Test Report (Part 27)

Report No.: RF180523C09-2 R1

FCC ID: 2AJOTTA-1087

Test Model: TA-1087

Received Date: May 23, 2018

Test Date: Jun. 07 ~ Jun. 15, 2018 (For all test data except LTE Band 41)
Aug. 31 ~ Sep. 04, 2018 (For LTE Band 41)

Issued Date: Oct. 24, 2018

Applicant: HMD Global Oy

Address: Bertel Jungin aukio 9, 02600 Espoo, Finland

Issued By: Bureau Veritas Consumer Products Services (H.K.) Ltd., Taoyuan Branch

Lab Address: No. 47-2, 14th Ling, Chia Pau Vil., Lin Kou Dist., New Taipei City, Taiwan, R.O.C.

Test Location: No. 19, Hwa Ya 2nd Rd., Wen Hwa Vil., Kwei Shan Dist., Taoyuan City 33383, TAIWAN (R.O.C.)



This report is for your exclusive use. Any copying or replication of this report to or for any other person or entity, or use of our name or trademark, is permitted only with our prior written permission. This report sets forth our findings solely with respect to the test samples identified herein. The results set forth in this report are not indicative or representative of the quality or characteristics of the lot from which a test sample was taken or any similar or identical product unless specifically and expressly noted. Our report includes all of the tests requested by you and the results thereof based upon the information that you provided to us. You have 60 days from date of issuance of this report to notify us of any material error or omission caused by our negligence, provided, however, that such notice shall be in writing and shall specifically address the issue you wish to raise. A failure to raise such issue within the prescribed time shall constitute your unqualified acceptance of the completeness of this report, the tests conducted and the correctness of the report contents. Unless specific mention, the uncertainty of measurement has been explicitly taken into account to declare the compliance or non-compliance to the specification. The report must not be used by the client to claim product certification, approval, or endorsement by TAF or any government agency

Table of Contents

Release Control Record	4
1 Certificate of Conformity	5
2 Summary of Test Results	6
2.1 Measurement Uncertainty.....	6
2.2 Test Site and Instruments.....	7
3 General Information	9
3.1 General Description of EUT.....	9
3.2 Configuration of System under Test.....	13
3.2.1 Description of Support Units.....	13
3.3 Test Mode Applicability and Tested Channel Detail.....	14
3.4 EUT Operating Conditions.....	29
3.5 General Description of Applied Standards.....	29
4 Test Types and Results	30
4.1 Output Power Measurement.....	30
4.1.1 Limits of Output Power Measurement.....	30
4.1.2 Test Procedures.....	30
4.1.3 Test Setup.....	31
4.1.4 Test Results.....	32
4.2 Modulation Characteristics Measurement.....	160
4.2.1 Limits of Modulation Characteristics.....	160
4.2.2 Test Procedure.....	160
4.2.3 Test Setup.....	160
4.2.4 Test Results.....	161
4.3 Frequency Stability Measurement.....	170
4.3.1 Limits of Frequency Stability Measurement.....	170
4.3.2 Test Procedure.....	170
4.3.3 Test Setup.....	170
4.3.4 Test Results.....	171
4.4 Emission Bandwidth Measurement.....	173
4.4.1 Limits of Emission Bandwidth Measurement.....	173
4.4.2 Test Procedure.....	173
4.4.3 Test Setup.....	173
4.4.4 Test Result.....	174
4.5 Channel Edge Measurement.....	197
4.5.1 Limits of Band Edge Measurement.....	197
4.5.2 Test Setup.....	197
4.5.3 Test Procedures.....	198
4.5.4 Test Results.....	198
4.6 Peak to Average Ratio.....	246
4.6.1 Limits of Peak to Average Ratio Measurement.....	246
4.6.2 Test Setup.....	246
4.6.3 Test Procedures.....	246
4.6.4 Test Results.....	247
4.7 Conducted Spurious Emissions.....	262
4.7.1 Limits of Conducted Spurious Emissions Measurement.....	262
4.7.2 Test Setup.....	262
4.7.3 Test Procedure.....	262
4.7.4 Test Results.....	263
4.8 Radiated Emission Measurement.....	363
4.8.1 Limits of Radiated Emission Measurement.....	363
4.8.2 Test Procedure.....	364
4.8.3 Deviation from Test Standard.....	364
4.8.4 Test Setup.....	364

4.8.5 Test Results	365
5 Pictures of Test Arrangements.....	469
Appendix – Information on the Testing Laboratories	470

Release Control Record

Issue No.	Description	Date Issued
RF180523C09-2	Original release	Jun. 20, 2018
RF180523C09-2 R1	1. Modified Band 41 bandwidth and test data 2. Revised applicant's address	Oct. 24, 2018

1 Certificate of Conformity

Product: Smart Phone
Brand: NOKIA
Test Model: TA-1087
Sample Status: Production Unit
Applicant: HMD Global Oy
Test Date: Jun. 07 ~ Jun. 15, 2018 (For all test data except LTE Band 41)
Aug. 31 ~ Sep. 04, 2018 (For LTE Band 41)
Standards: FCC Part 27, Subpart C, D, L, H, F, M

The above equipment has been tested by **Bureau Veritas Consumer Products Services (H.K.) Ltd., Taoyuan Branch**, and found compliance with the requirement of the above standards. The test record, data evaluation & Equipment Under Test (EUT) configurations represented herein are true and accurate accounts of the measurements of the sample's RF characteristics under the conditions specified in this report.

Prepared by : Pettie Chen , **Date:** Oct. 24, 2018
Pettie Chen / Senior Specialist

Approved by : Bruce Chen , **Date:** Oct. 24, 2018
Bruce Chen / Project Engineer

2 Summary of Test Results

Applied Standard: FCC Part 27 & Part 2										
FCC Clause								Test Item	Result	Remarks
WCDMA Band 4 / LTE Band 4	LTE Band 7	LTE Band 12	LTE Band 13	LTE Band 17	LTE Band 38	LTE Band 41	LTE Band 66			
2.1046 27.50 (d)(4)	2.1046 27.50(h)	2.1046 27.50 (b)(10)	2.1046 27.50 (b)(10)	2.1046 27.50 (c)(10)	2.1046 27.50(h)	2.1046 27.50 (h)(2)	2.1046 27.50 (d)(4)	Equivalent Isotropically Radiated Power	Pass	Meet the requirement of limit.
----	----	----	----	----	----	----	----	Peak To Average Ratio	Pass	Meet the requirement of limit.
2.1055 27.54	2.1055 27.54	2.1055 27.54	2.1055 27.54	2.1055 27.54	2.1055 27.54	2.1055 27.54	2.1055 27.54	Frequency Stability Stay with the authorized bands of operation	Pass	Meet the requirement of limit.
2.1049 27.53 (m)(6)	2.1049 27.53 (h)	2.1049 27.53 (m)(6)	2.1049 27.53 (m)(6)	2.1049 27.53 (m)(6)	2.1049 27.53 (h)	2.1049 27.53 (m)(6)	2.1049 27.53 (m)(6)	Emission Bandwidth	Pass	Meet the requirement of limit.
2.1051 27.53(h)	2.1051 27.53(m)	2.1051 27.53(c)	2.1051 27.53(c)	2.1051 27.53(g)	2.1051 27.53(m)	2.1051 27.53(m) (4)(6)	2.1051 27.53(h)	Band Edge Measurements	Pass	Meet the requirement of limit.
2.1051 27.53(h)	2.1051 27.53(m)	2.1051 27.53(c)	2.1051 27.53(c)	2.1051 27.53(g)	2.1051 27.53(m)	2.1051 27.53(m) (4)(6)	2.1051 27.53(h)	Conducted Spurious Emissions	Pass	Meet the requirement of limit.
2.1051 27.53(h)	2.1053 27.53(m)	2.1051 27.53(c)	2.1051 27.53(c)	2.1051 27.53(g)	2.1053 27.53(m)	2.1053 27.53(m) (4)(6)	2.1051 27.53(h)	Radiated Spurious Emissions	Pass	Meet the requirement of limit. Minimum passing margin is -13.6dB at 30.00MHz.

2.1 Measurement Uncertainty

Where relevant, the following measurement uncertainty levels have been estimated for tests performed on the EUT as specified in CISPR 16-4-2:

Measurement	Frequency	Expanded Uncertainty (k=2) (±)
Radiated Emissions up to 1 GHz	30MHz ~ 200MHz	3.59 dB
	200MHz ~1000MHz	3.60 dB
Radiated Emissions above 1 GHz	1GHz ~ 18GHz	2.29 dB
	18GHz ~ 40GHz	2.29 dB

2.2 Test Site and Instruments

For test date: Jun. 07 ~ Jun. 15, 2018

Description & Manufacturer	Model No.	Serial No.	Cal. Date	Cal. Due
Test Receiver KEYSIGHT	N9038A	MY55420137	Apr. 11, 2018	Apr. 10, 2019
Spectrum Analyzer ROHDE & SCHWARZ	FSP40	100269	May 29, 2018	May 28, 2019
BILOG Antenna SCHWARZBECK	VULB9168	9168-148	Dec. 11, 2017	Dec. 10, 2018
HORN Antenna SCHWARZBECK	BBHA 9120 D	9120D-1169	Dec. 12, 2017	Dec. 11, 2018
HORN Antenna SCHWARZBECK	BBHA 9170	BBHA9170241	Dec. 01, 2017	Nov. 30, 2018
Loop Antenna EMCI	EM-6879	269	Aug. 11, 2017	Aug. 10, 2018
Preamplifier Agilent (Below 1GHz)	8447D	2944A10638	Aug. 08, 2017	Aug. 07, 2018
Preamplifier Agilent (Above 1GHz)	8449B	3008A01638	Feb. 22, 2018	Feb. 21, 2019
RF signal cable HUBER+SUHNER&EMCI	SUCOFLEX 104 & EMC104-SM-SM8000	CABLE-CH9-02 (248780+171006)	Jan. 15, 2018	Jan. 14, 2019
RF signal cable HUBER+SUHNER	SUCOFLEX 104	CABLE-CH9-(250795/4)	Aug. 08, 2017	Aug. 07, 2018
RF signal cable Woken	8D-FB	Cable-CH9-01	Aug. 01, 2017	Jul. 31, 2018
Software BV ADT	ADT_Radiated_ V7.6.15.9.5	NA	NA	NA
Antenna Tower EMCO	2070/2080	512.835.4684	NA	NA
Turn Table EMCO	2087-2.03	NA	NA	NA
Antenna Tower & Turn BV ADT	AT100	AT93021705	NA	NA
Turn Table BV ADT	TT100	TT93021705	NA	NA
Turn Table Controller BV ADT	SC100	SC93021705	NA	NA
Boresight Antenna Fixture	FBA-01	FBA-SIP01	NA	NA
Turn Table Controller BV ADT	SC100	SC93021702	NA	NA
Temperature And Humidity Chamber TERCHY	HRM-120RF	931022	Nov. 20, 2017	Nov. 19, 2018
JFW 20dB attenuation	50HF-020-SMA	NA	NA	NA
Radio Communication Analyzer	MT8821C	6261786083	Dec. 21, 2017	Dec. 20, 2018

- Note: 1. The calibration interval of the above test instruments is 12 months and the calibrations are traceable to NML/ROC and NIST/USA.
2. The test was performed in HwaYa Chamber 9.
3. The FCC Designation Number is TW0003. The number will be varied with the Lab location and scope as attached.
4. The IC Site Registration No. is IC 7450F-9.

For test date: Aug. 31 ~ Sep. 04, 2018

Description & Manufacturer	Model No.	Serial No.	Cal. Date	Cal. Due
Test Receiver KEYSIGHT	N9038A	MY55420137	Apr. 11, 2018	Apr. 10, 2019
Spectrum Analyzer ROHDE & SCHWARZ	FSP40	100269	May 29, 2018	May 28, 2019
BILOG Antenna SCHWARZBECK	VULB9168	9168-148	Dec. 11, 2017	Dec. 10, 2018
HORN Antenna SCHWARZBECK	BBHA 9120 D	9120D-1169	Dec. 12, 2017	Dec. 11, 2018
HORN Antenna SCHWARZBECK	BBHA 9170	BBHA9170241	Dec. 01, 2017	Nov. 30, 2018
Loop Antenna TESEQ	HLA 6121	45745	Jun. 14, 2018	Jun. 13, 2019
Preamplifier Agilent (Below 1GHz)	8447D	2944A10638	Aug. 08, 2018	Aug. 07, 2019
Preamplifier Agilent (Above 1GHz)	8449B	3008A01638	Feb. 22, 2018	Feb. 21, 2019
RF signal cable HUBER+SUHNER&EMCI	SUCOFLEX 104 & EMC104-SM-SM8000	CABLE-CH9-02 (248780+171006)	Jan. 15, 2018	Jan. 14, 2019
RF signal cable HUBER+SUHNER	SUCOFLEX 104	CABLE-CH9-(250795/4)	Aug. 08, 2017	Aug. 07, 2018
RF signal cable Woken	8D-FB	Cable-CH9-01	Jul. 31, 2018	Jul. 30, 2019
Software BV ADT	ADT_Radiated_ V7.6.15.9.5	NA	NA	NA
Antenna Tower EMCO	2070/2080	512.835.4684	NA	NA
Turn Table EMCO	2087-2.03	NA	NA	NA
Antenna Tower & Turn BV ADT	AT100	AT93021705	NA	NA
Turn Table BV ADT	TT100	TT93021705	NA	NA
Turn Table Controller BV ADT	SC100	SC93021705	NA	NA
Boresight Antenna Fixture	FBA-01	FBA-SIP01	NA	NA
Turn Table Controller BV ADT	SC100	SC93021702	NA	NA
Temperature And Humidity Chamber TERCHY	HRM-120RF	931022	Nov. 20, 2017	Nov. 19, 2018
JFW 20dB attenuation	50HF-020-SMA	NA	NA	NA
Radio Communication Analyzer	MT8821C	6261786083	Dec. 21, 2017	Dec. 20, 2018

- Note: 1. The calibration interval of the above test instruments is 12 months and the calibrations are traceable to NML/ROC and NIST/USA.
 2. The test was performed in HwaYa Chamber 9.
 3. The FCC Designation Number is TW0003. The number will be varied with the Lab location and scope as attached.
 4. The IC Site Registration No. is IC 7450F-9.

3 General Information

3.1 General Description of EUT

Product	SmartPhone		
Brand	NOKIA		
Test Model	TA-1087		
Status of EUT	Production Unit		
Power Supply Rating	5.0 Vdc or 9 Vdc or 12 Vdc (adapter) 5.0 Vdc (host equipment) 3.85 Vdc (Li-ion battery)		
Modulation Type	WCDMA: BPSK, QPSK HSDPA: BPSK HSUPA: QPSK LTE: QPSK, 16QAM, 64QAM		
Operating Frequency	WCDMA Band 4		1712.4MHz ~ 1752.6MHz
	LTE Band 4	Channel Bandwidth 1.4MHz	1710.7MHz ~ 1754.3MHz
		Channel Bandwidth 3MHz	1711.5MHz ~ 1753.5MHz
		Channel Bandwidth 5MHz	1712.5MHz ~ 1752.5MHz
		Channel Bandwidth 10MHz	1715.0MHz ~ 1750.0MHz
		Channel Bandwidth 15MHz	1717.5MHz ~ 1747.5MHz
		Channel Bandwidth 20MHz	1720.0MHz ~ 1745.0MHz
	LTE Band 7	Channel Bandwidth 5MHz	2622.5MHz ~ 2687.5MHz
		Channel Bandwidth 10MHz	2625.0MHz ~ 2685.0MHz
		Channel Bandwidth 15MHz	2627.5MHz ~ 2682.5MHz
		Channel Bandwidth 20MHz	2630.0MHz ~ 2680.0MHz
		Channel Bandwidth 5+20MHz	2502.5MHz ~ 2555.8MHz
		Channel Bandwidth 10+15MHz	2505.0MHz ~ 2553.0MHz
		Channel Bandwidth 10+20MHz	2505.0MHz ~ 2550.6MHz
		Channel Bandwidth 15+10MHz	2507.5MHz ~ 2550.5MHz
		Channel Bandwidth 15+15MHz	2507.5MHz ~ 2547.5MHz
		Channel Bandwidth 15+20MHz	2507.5MHz ~ 2545.4MHz
		Channel Bandwidth 20+5MHz	2510.0MHz ~ 2548.3MHz
		Channel Bandwidth 20+10MHz	2510.0MHz ~ 2545.6MHz
		Channel Bandwidth 20+15MHz	2510.0MHz ~ 2542.9MHz
		Channel Bandwidth 20+20MHz	2510.0MHz ~ 2540.2MHz
	LTE Band 12	Channel Bandwidth 1.4MHz	699.7MHz ~ 715.3MHz
		Channel Bandwidth 3MHz	700.5MHz ~ 714.5MHz
		Channel Bandwidth 5MHz	701.5MHz ~ 713.5MHz
		Channel Bandwidth 10MHz	704.0MHz ~ 711.0MHz
	LTE Band 13	Channel Bandwidth 5MHz	779.5MHz ~ 784.5MHz
		Channel Bandwidth 10MHz	782.0MHz

Operating Frequency	LTE Band 17	Channel Bandwidth 5MHz	706.5MHz ~ 713.5MHz			
		Channel Bandwidth 10MHz	709.0MHz ~ 711.0MHz			
	LTE Band 38	Channel Bandwidth 5MHz	2572.5MHz ~ 2617.5MHz			
		Channel Bandwidth 10MHz	2575.0MHz ~ 2615.0MHz			
		Channel Bandwidth 15MHz	2577.5MHz ~ 2615.0MHz			
		Channel Bandwidth 20MHz	2580.0MHz ~ 2610.0MHz			
	LTE Band 41	Channel Bandwidth 5MHz	2537.5MHz ~ 2652.5MHz			
		Channel Bandwidth 10MHz	2540MHz ~ 2650MHz			
		Channel Bandwidth 15MHz	2542.5MHz ~ 2647.5MHz			
		Channel Bandwidth 20MHz	2545MHz ~ 2645MHz			
	LTE Band 66	Channel Bandwidth 1.4MHz	1710.7MHz ~ 1779.3MHz			
		Channel Bandwidth 3MHz	1711.5MHz ~ 1778.5MHz			
		Channel Bandwidth 5MHz	1712.5MHz ~ 1775.00MHz			
		Channel Bandwidth 10MHz	1715.0MHz ~ 1772.5MHz			
		Channel Bandwidth 15MHz	1717.5MHz ~ 1747.5MHz			
		Channel Bandwidth 20MHz	1720.0MHz ~ 1770.0MHz			
	Max. EIRP Power	WCDMA Band 4		457.088mW (26.6dBm)		
				QPSK	16QAM	64QAM
LTE Band 4		Channel Bandwidth 1.4MHz	245.471mW (23.9dBm)	194.984mW (22.9dBm)	190.546mW (22.8dBm)	
		Channel Bandwidth 3MHz	263.027mW (24.2dBm)	213.796mW (23.3dBm)	208.930mW (23.2dBm)	
		Channel Bandwidth 5MHz	257.040mW (24.1dBm)	199.526mW (23.0dBm)	190.546mW (22.8dBm)	
		Channel Bandwidth 10MHz	263.027mW (24.2dBm)	199.526mW (23.0dBm)	194.984mW (22.9dBm)	
		Channel Bandwidth 15MHz	269.153mW (24.3dBm)	218.776mW (23.4dBm)	208.930mW (23.2dBm)	
		Channel Bandwidth 20MHz	295.121mW (24.7dBm)	234.423mW (23.7dBm)	229.087mW (23.6dBm)	
LTE Band 7		Channel Bandwidth 5MHz	151.356mW (21.8dBm)	123.027mW (20.9dBm)	109.648mW (20.4dBm)	
		Channel Bandwidth 10MHz	162.181mW (22.1dBm)	131.826mW (21.2dBm)	125.893mW (21.0dBm)	
		Channel Bandwidth 15MHz	173.780mW (22.4dBm)	141.254mW (21.5dBm)	131.826mW (21.2dBm)	
		Channel Bandwidth 20MHz	181.970mW (22.6dBm)	147.911mW (21.7dBm)	138.038mW (21.4dBm)	
		Channel Bandwidth 20+20MHz	190.546mW (22.8dBm)	-	-	
LTE Band 38		Channel Bandwidth 5MHz	323.594mW (25.1dBm)	257.040mW (24.1dBm)	234.423mW (23.7dBm)	
		Channel Bandwidth 10MHz	269.153mW (24.3dBm)	218.776mW (23.4dBm)	204.174mW (23.1dBm)	
		Channel Bandwidth 15MHz	309.030mW (24.9dBm)	239.883mW (23.8dBm)	218.776mW (23.4dBm)	
		Channel Bandwidth 20MHz	316.228mW (25.0dBm)	257.040mW (24.1dBm)	234.423mW (23.7dBm)	

Max. EIRP Power	LTE Band 41		QPSK	16QAM	64QAM
		Channel Bandwidth 5MHz	309.030mW (24.9dBm)	245.471mW (23.9dBm)	218.776mW (23.4dBm)
	Channel Bandwidth 10MHz	316.228mW (25.0dBm)	275.423mW (24.4dBm)	239.883mW (23.8dBm)	
	Channel Bandwidth 15MHz	269.153mW (24.3dBm)	213.796mW (23.3dBm)	186.209mW (22.7dBm)	
	Channel Bandwidth 20MHz	275.423mW (24.4dBm)	223.872mW (23.5dBm)	119.526mW (23.0dBm)	
Max. EIRP Power	LTE Band 66	Channel Bandwidth 1.4MHz	812.831mW (29.1dBm)	645.654mW (28.1dBm)	630.957mW (28.0dBm)
		Channel Bandwidth 3MHz	851.138mW (29.3dBm)	691.831mW (28.4dBm)	676.083mW (28.3dBm)
		Channel Bandwidth 5MHz	831.764mW (29.2dBm)	676.083mW (28.3dBm)	660.693mW (28.2dBm)
		Channel Bandwidth 10MHz	831.764mW (29.2dBm)	676.083mW (28.3dBm)	660.693mW (28.2dBm)
		Channel Bandwidth 15MHz	851.138mW (29.3dBm)	676.083mW (28.3dBm)	660.693mW (28.2dBm)
		Channel Bandwidth 20MHz	776.247mW (28.9dBm)	630.957mW (28.0dBm)	575.440mW (27.6dBm)
Max. ERP Power	LTE Band 12	Channel Bandwidth 1.4MHz	89.125mW (19.5dBm)	72.444mW (18.6dBm)	69.183mW (18.4dBm)
		Channel Bandwidth 3MHz	87.096mW (19.4dBm)	69.183mW (18.4dBm)	66.069mW (18.2dBm)
		Channel Bandwidth 5MHz	85.114mW (19.3dBm)	67.608mW (18.3dBm)	64.565mW (18.1dBm)
		Channel Bandwidth 10MHz	89.125mW (19.5dBm)	69.183mW (18.4dBm)	66.069mW (18.2dBm)
	LTE Band 13	Channel Bandwidth 5MHz	83.176mW (19.2dBm)	66.069mW (18.2dBm)	66.069mW (18.2dBm)
		Channel Bandwidth 10MHz	81.283mW (19.1dBm)	64.565mW (18.1dBm)	61.660mW (17.9dBm)
	LTE Band 17	Channel Bandwidth 5MHz	70.795mW (18.5dBm)	54.954mW (17.4dBm)	53.703mW (17.3dBm)
		Channel Bandwidth 10MHz	67.608mW (18.3dBm)	52.481mW (17.2dBm)	51.286mW (17.1dBm)

Emission Designator	WCDMA Band 4		4M13F9W		
			QPSK	16QAM	64QAM
Emission Designator	LTE Band 4	Channel Bandwidth 1.4MHz	1M09G7D	1M09W7D	1M09W7D
		Channel Bandwidth 3MHz	2M69G7D	2M69W7D	2M68W7D
		Channel Bandwidth 5MHz	4M48G7D	4M46W7D	4M48W7D
		Channel Bandwidth 10MHz	8M93G7D	8M96W7D	8M93W7D
		Channel Bandwidth 15MHz	13M4G7D	13M4W7D	13M4W7D
		Channel Bandwidth 20MHz	17M9G7D	17M8W7D	17M9W7D
	LTE Band 7	Channel Bandwidth 5MHz	4M48G7D	4M48W7D	4M48W7D
		Channel Bandwidth 10MHz	8M93G7D	8M93W7D	8M96W7D
		Channel Bandwidth 15MHz	13M4G7D	13M4W7D	13M4W7D
		Channel Bandwidth 20MHz	18M0G7D	17M9W7D	17M9W7D
		Channel Bandwidth 20+20MHz	37M6G7D	-	-
	LTE Band 12	Channel Bandwidth 1.4MHz	1M09G7D	1M09W7D	1M09W7D
		Channel Bandwidth 3MHz	2M69G7D	2M69W7D	2M68W7D
		Channel Bandwidth 5MHz	4M48G7D	4M48W7D	4M50W7D
		Channel Bandwidth 10MHz	8M96G7D	8M96W7D	8M96W7D
	LTE Band 13	Channel Bandwidth 5MHz	4M48G7D	4M48W7D	4M48W7D
		Channel Bandwidth 10MHz	8M93G7D	8M93W7D	8M93W7D
	LTE Band 17	Channel Bandwidth 5MHz	4M48G7D	4M48W7D	4M48W7D
		Channel Bandwidth 10MHz	8M96G7D	9M00W7D	8M96W7D
	LTE Band 38	Channel Bandwidth 5MHz	4M46G7D	4M45W7D	4M46W7D
		Channel Bandwidth 10MHz	8M90G7D	8M93W7D	8M93W7D
		Channel Bandwidth 15MHz	13M4G7D	13M3W7D	13M4W7D
		Channel Bandwidth 20MHz	17M9G7D	17M9W7D	17M9W7D
	LTE Band 41	Channel Bandwidth 5MHz	4M46G7D	4M48W7D	4M48W7D
		Channel Bandwidth 10MHz	8M93G7D	8M96W7D	8M96W7D
		Channel Bandwidth 15MHz	13M4G7D	13M4W7D	13M4W7D
		Channel Bandwidth 20MHz	17M8G7D	18M0W7D	17M9W7D
	LTE Band 66	Channel Bandwidth 1.4MHz	1M08G7D	1M09W7D	1M09W7D
Channel Bandwidth 3MHz		2M69G7D	2M69W7D	2M68W7D	
Channel Bandwidth 5MHz		4M46G7D	4M46W7D	4M48W7D	
Channel Bandwidth 10MHz		8M93G7D	8M93W7D	8M93W7D	
Channel Bandwidth 15MHz		13M4G7D	13M4W7D	13M4W7D	
Channel Bandwidth 20MHz		18M0G7D	17M9W7D	18M0W7D	

Antenna Connector	WCDMA Band 4, LTE Band 4, LTE Band 66: Main Ant.: Fixed Internal antenna with 1.6dBi gain Aux. Ant.: Fixed Internal antenna with -3.3dBi gain LTE Band 7, LTE Band 38: Main Ant.: Fixed Internal antenna with 0.2dBi gain Aux. Ant.: Fixed Internal antenna with -1.2dBi gain LTE Band 12, LTE Band 13, LTE Band 17: Main Ant.: Fixed Internal antenna with -2.1dBi gain Aux. Ant.: Fixed Internal antenna with -1.2dBi gain LTE Band 41: Main Ant.: Fixed Internal antenna with 0.7dBi gain Aux. Ant.: Fixed Internal antenna with -1.2dBi gain (Brand: TongDa Electrics, Model: MEAOP61010A)
Antenna Connector	NA
Accessory Device	Refer to Note as below
Data Cable Supplied	Refer to Note as below

Note: The EUT's accessories list refers to Ext. Pho.

3.2 Configuration of System under Test

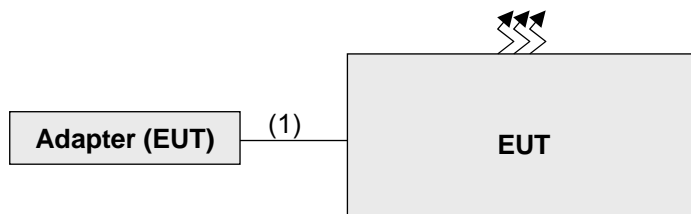

3.2.1 Description of Support Units

The EUT has been tested as an independent unit together with other necessary accessories or support units. The following support units or accessories were used to form a representative test configuration during the tests.

ID	Descriptions	Qty.	Length (m)	Shielding (Yes/No)	Cores (Qty.)	Remarks
1.	USB cable	1	1.0	N	0	Accessory Device

3.3 Test Mode Applicability and Tested Channel Detail

Pre-Scan has been conducted to determine the worst-case mode from all possible combinations between available modulations, data rates, XYZ axis and antenna ports. The worst case was found when positioned on X-plane. Following channel(s) was (were) selected for the final test as listed below:

WCDMA Band 4 Mode

EUT Configure Mode	Test Item	Available Channel	Tested Channel	Mode
-	EIRP	1312 to 1513	1312(1712.4MHz), 1413(1732.6MHz), 1513(1752.6MHz)	WCDMA
-	Modulation Characteristics	1312 to 1513	1413(1732.6MHz)	WCDMA
-	Frequency Stability	1312 to 1513	1413(1732.6MHz)	WCDMA
-	Occupied Bandwidth	1312 to 1513	1312(1712.4MHz), 1413(1732.6MHz), 1513(1752.6MHz)	WCDMA
-	Band Edge	1312 to 1513	1312(1712.4MHz), 1513(1752.6MHz)	WCDMA
-	Peak To Average Ratio	1312 to 1513	1312(1712.4MHz), 1413(1732.6MHz), 1513(1752.6MHz)	WCDMA
-	Conducted Emission	1312 to 1513	1312(1712.4MHz), 1413(1732.6MHz), 1513(1752.6MHz)	WCDMA
-	Radiated Emission Below 1GHz	1312 to 1513	1312(1712.4MHz)	WCDMA
-	Radiated Emission Above 1GHz	1312 to 1513	1312(1712.4MHz), 1413(1732.6MHz), 1513(1752.6MHz)	WCDMA

LTE Band 4

EUT Configure Mode	Test Item	Available Channel	Tested Channel	Channel Bandwidth	Modulation	Mode
-	EIRP	19957 to 20393	19957(1710.7MHz), 20175(1732.5MHz), 20393(1754.3MHz)	1.4MHz	QPSK / 16QAM / 64QAM	1 RB / 0 RB Offset
		19965 to 20385	19965(1711.5MHz), 20175(1732.5MHz), 20385(1753.5MHz)	3MHz	QPSK / 16QAM / 64QAM	1 RB / 0 RB Offset
		19975 to 20375	19975(1712.5MHz), 20175(1732.5MHz), 20375(1752.5MHz)	5MHz	QPSK / 16QAM / 64QAM	1 RB / 0 RB Offset
		20000 to 20350	20000(1715.0MHz), 20175(1732.5MHz), 20350(1750.0MHz)	10MHz	QPSK / 16QAM / 64QAM	1 RB / 0 RB Offset
		20025 to 20325	20025(1717.5MHz), 20175(1732.5MHz), 20325(1747.5MHz)	15MHz	QPSK / 16QAM / 64QAM	1 RB / 0 RB Offset
		20050 to 20300	20050(1720.0MHz), 20175(1732.5MHz), 20300(1745.0MHz)	20MHz	QPSK / 16QAM / 64QAM	1 RB / 0 RB Offset
-	Modulation Characteristics	19957 to 20393	20175(1732.5MHz)	1.4MHz	QPSK / 16QAM	1 RB / 0 RB Offset
		20050 to 20300	20175(1732.5MHz)	20MHz	QPSK / 16QAM	100 RB / 0 RB Offset
-	Frequency Stability	19957 to 20393	20175(1732.5MHz)	1.4MHz	QPSK	1 RB / 0 RB Offset
-	Emission Bandwidth	19957 to 20393	19957(1710.7MHz), 20175(1732.5MHz), 20393(1754.3MHz)	1.4MHz	QPSK / 16QAM / 64QAM	6 RB / 0 RB Offset
		19965 to 20385	19965(1711.5MHz), 20175(1732.5MHz), 20385(1753.5MHz)	3MHz	QPSK / 16QAM / 64QAM	15 RB / 0 RB Offset
		19975 to 20375	19975(1712.5MHz), 20175(1732.5MHz), 20375(1752.5MHz)	5MHz	QPSK / 16QAM / 64QAM	25 RB / 0 RB Offset
		20000 to 20350	20000(1715.0MHz), 20175(1732.5MHz), 20350(1750.0MHz)	10MHz	QPSK / 16QAM / 64QAM	50 RB / 0 RB Offset
		20025 to 20325	20025(1717.5MHz), 20175(1732.5MHz), 20325(1747.5MHz)	15MHz	QPSK / 16QAM / 64QAM	75 RB / 0 RB Offset
		20050 to 20300	20050(1720.0MHz), 20175(1732.5MHz), 20300(1745.0MHz)	20MHz	QPSK / 16QAM / 64QAM	100 RB / 0 RB Offset
-	Band Edge	19957 to 20393	19957(1710.7MHz), 20393(1754.3MHz)	1.4MHz	QPSK	1 RB / 0 RB Offset 1 RB / 5 RB Offset 6 RB / 0 RB Offset
		19965 to 20385	19965(1711.5MHz), 20385(1753.5MHz)	3MHz	QPSK	1 RB / 0 RB Offset 1 RB / 14 RB Offset 15 RB / 0 RB Offset
		19975 to 20375	19975(1712.5MHz), 20375(1752.5MHz)	5MHz	QPSK	1 RB / 0 RB Offset 1 RB / 24 RB Offset 25 RB / 0 RB Offset
		20000 to 20350	20000(1715.0MHz), 20350(1750.0MHz)	10MHz	QPSK	1 RB / 0 RB Offset 1 RB / 49 RB Offset 50 RB / 0 RB Offset
		20025 to 20325	20025(1717.5MHz), 20325(1747.5MHz)	15MHz	QPSK	1 RB / 0 RB Offset 1 RB / 74 RB Offset 75 RB / 0 RB Offset
		20050 to 20300	20050(1720.0MHz), 20300(1745.0MHz)	20MHz	QPSK	1 RB / 0 RB Offset 1 RB / 99 RB Offset 100 RB / 0 RB Offset

EUT Configure Mode	Test Item	Available Channel	Tested Channel	Channel Bandwidth	Modulation	Mode
-	Conducted Emission	19957 to 20393	19957(1710.7MHz), 20175(1732.5MHz), 20393(1754.3MHz)	1.4MHz	QPSK	6 RB / 0 RB Offset
		19965 to 20385	19965(1711.5MHz), 20175(1732.5MHz), 20385(1753.5MHz)	3MHz	QPSK	15 RB / 0 RB Offset
		19975 to 20375	19975(1712.5MHz), 20175(1732.5MHz), 20375(1752.5MHz)	5MHz	QPSK	25 RB / 0 RB Offset
		20000 to 20350	20000(1715.0MHz), 20175(1732.5MHz), 20350(1750.0MHz)	10MHz	QPSK	50 RB / 0 RB Offset
		20025 to 20325	20025(1717.5MHz), 20175(1732.5MHz), 20325(1747.5MHz)	15MHz	QPSK	75 RB / 0 RB Offset
		20050 to 20300	20050(1720.0MHz), 20175(1732.5MHz), 20300(1745.0MHz)	20MHz	QPSK	100 RB / 0 RB Offset
-	Radiated Emission Below 1GHz	19957 to 20393	19957(1710.7MHz)	1.4MHz	QPSK	1 RB / 0 RB Offset
		19965 to 20385	19965(1711.5MHz)	3MHz	QPSK	1 RB / 0 RB Offset
		19975 to 20375	19975(1712.5MHz)	5MHz	QPSK	1 RB / 0 RB Offset
		20000 to 20350	20000(1715.0MHz)	10MHz	QPSK	1 RB / 0 RB Offset
		20025 to 20325	20025(1717.5MHz)	15MHz	QPSK	1 RB / 0 RB Offset
		20050 to 20300	20050(1720.0MHz)	20MHz	QPSK	1 RB / 0 RB Offset
-	Radiated Emission Above 1GHz	19957 to 20393	19957(1710.7MHz), 20175(1732.5MHz), 20393(1754.3MHz)	1.4MHz	QPSK	1 RB / 0 RB Offset
		19965 to 20385	19965(1711.5MHz), 20175(1732.5MHz), 20385(1753.5MHz)	3MHz	QPSK	1 RB / 0 RB Offset
		19975 to 20375	19975(1712.5MHz), 20175(1732.5MHz), 20375(1752.5MHz)	5MHz	QPSK	1 RB / 0 RB Offset
		20000 to 20350	20000(1715.0MHz), 20175(1732.5MHz), 20350(1750.0MHz)	10MHz	QPSK	1 RB / 0 RB Offset
		20025 to 20325	20025(1717.5MHz), 20175(1732.5MHz), 20325(1747.5MHz)	15MHz	QPSK	1 RB / 0 RB Offset
		20050 to 20300	20050(1720.0MHz), 20175(1732.5MHz), 20300(1745.0MHz)	20MHz	QPSK	1 RB / 0 RB Offset

LTE Band 7

EUT Configure Mode	Test Item	Available Channel	Tested Channel	Channel Bandwidth	Modulation	Mode
-	EIRP	2775 to 3425	20775(2502.5MHz), 21100(2535.0MHz), 21425(2567.5MHz)	5MHz	QPSK / 16QAM / 64QAM	1 RB / 0 RB Offset
		2800 to 3400	20800(2505.0MHz), 21100(2535.0MHz), 21400(2565.0MHz),	10MHz	QPSK / 16QAM / 64QAM	1 RB / 0 RB Offset
		2825 to 3375	20825(2507.5MHz), 21100(2535.0MHz), 21375(2562.5MHz)	15MHz	QPSK / 16QAM / 64QAM	1 RB / 0 RB Offset
		2850 to 3350	20850(2510.0MHz), 21100(2535.0MHz), 21350(2560.0MHz)	20MHz	QPSK / 16QAM / 64QAM	1 RB / 0 RB Offset
-	Modulation Characteristics	2775 to 3425	21100(2535.0MHz)	5MHz	QPSK / 16QAM	1 RB / 0 RB Offset
		2850 to 3350	21100(2535.0MHz)	20MHz	QPSK / 16QAM	1 RB / 0 RB Offset
-	Frequency Stability	2775 to 3425	21100(2535.0MHz)	5MHz	QPSK	1 RB / 0 RB Offset
-	Emission Bandwidth	2775 to 3425	20775(2502.5MHz), 21100(2535.0MHz), 21425(2567.5MHz)	5MHz	QPSK / 16QAM / 64QAM	25 RB / 0 RB Offset
		2800 to 3400	20800(2505.0MHz), 21100(2535.0MHz), 21400(2565.0MHz),	10MHz	QPSK / 16QAM / 64QAM	50 RB / 0 RB Offset
		2825 to 3375	20825(2507.5MHz), 21100(2535.0MHz), 21375(2562.5MHz)	15MHz	QPSK / 16QAM / 64QAM	75 RB / 0 RB Offset
		2850 to 3350	20850(2510.0MHz), 21100(2535.0MHz), 21350(2560.0MHz)	20MHz	QPSK / 16QAM / 64QAM	100 RB / 0 RB Offset
-	Band Edge	2775 to 3425	20775(2502.5MHz), 21425(2567.5MHz)	5MHz	QPSK	1 RB / 0 RB Offset 1 RB / 24 RB Offset 25 RB / 0 RB Offset
		2800 to 3400	20800(2505.0MHz), 21400(2565.0MHz),	10MHz	QPSK	1 RB / 0 RB Offset 1 RB / 49 RB Offset 50 RB / 0 RB Offset
		2825 to 3375	20825(2507.5MHz), 21375(2562.5MHz)	15MHz	QPSK	1 RB / 0 RB Offset 1 RB / 74 RB Offset 75 RB / 0 RB Offset
		2850 to 3350	20850(2510.0MHz), 21350(2560.0MHz)	20MHz	QPSK	1 RB / 0 RB Offset 1 RB / 99 RB Offset 100 RB / 0 RB Offset
-	Peak To Average Ratio	2775 to 3425	20775(2502.5MHz), 21100(2535.0MHz), 21425(2567.5MHz)	5MHz	QPSK / 16QAM / 64QAM	1 RB / 0 RB Offset
		2800 to 3400	20800(2505.0MHz), 21100(2535.0MHz), 21400(2565.0MHz),	10MHz	QPSK / 16QAM / 64QAM	1 RB / 0 RB Offset
		2825 to 3375	20825(2507.5MHz), 21100(2535.0MHz), 21375(2562.5MHz)	15MHz	QPSK / 16QAM / 64QAM	1 RB / 0 RB Offset
		2850 to 3350	20850(2510.0MHz), 21100(2535.0MHz), 21350(2560.0MHz)	20MHz	QPSK / 16QAM / 64QAM	1 RB / 0 RB Offset
-	Conducted Emission	2775 to 3425	20775(2502.5MHz), 21100(2535.0MHz), 21425(2567.5MHz)	5MHz	QPSK	25 RB / 0 RB Offset
		2800 to 3400	20800(2505.0MHz), 21100(2535.0MHz), 21400(2565.0MHz),	10MHz	QPSK	50 RB / 0 RB Offset
		2825 to 3375	20825(2507.5MHz), 21100(2535.0MHz), 21375(2562.5MHz)	15MHz	QPSK	75 RB / 0 RB Offset
		2850 to 3350	20850(2510.0MHz), 21100(2535.0MHz), 21350(2560.0MHz)	20MHz	QPSK	100 RB / 0 RB Offset

EUT Configure Mode	Test Item	Available Channel	Tested Channel	Channel Bandwidth	Modulation	Mode
-	Radiated Emission Below 1GHz	2775 to 3425	20775(2502.5MHz)	5MHz	QPSK	1 RB / 0 RB Offset
		2800 to 3400	20800(2505.0MHz)	10MHz	QPSK	1 RB / 0 RB Offset
		2825 to 3375	20825(2507.5MHz)	15MHz	QPSK	1 RB / 0 RB Offset
		2850 to 3350	20850(2510.0MHz)	20MHz	QPSK	1 RB / 0 RB Offset
-	Radiated Emission Above 1GHz	2775 to 3425	20775(2502.5MHz), 21100(2535.0MHz), 21425(2567.5MHz)	5MHz	QPSK	1 RB / 0 RB Offset
		2800 to 3400	20800(2505.0MHz), 21100(2535.0MHz), 21400(2565.0MHz)	10MHz	QPSK	1 RB / 0 RB Offset
		2825 to 3375	20825(2507.5MHz), 21100(2535.0MHz), 21375(2562.5MHz)	15MHz	QPSK	1 RB / 0 RB Offset
		2850 to 3350	20850(2510.0MHz), 21100(2535.0MHz), 21350(2560.0MHz)	20MHz	QPSK	1 RB / 0 RB Offset

LTE Band 7 CA Mode

EUT Configure Mode	Test Item	Available Channel	Tested Channel	Channel Bandwidth	Modulation	Mode
-	EIRP	2850 to 3350	20850(2510.0MHz), +21048(2529.8MHz), 21100(2535.0MHz), +21298(2554.8MHz), 21350(2560.0MHz), +21152(2540.2MHz)	20MHz	QPSK	1 RB / 0 RB Offset
-	Emission Bandwidth	2850 to 3350	20850(2510.0MHz), +21048(2529.8MHz), 21100(2535.0MHz), +21298(2554.8MHz), 21350(2560.0MHz), +21152(2540.2MHz)	20MHz	QPSK / 16QAM / 64QAM	100 RB / 0 RB Offset
-	Band Edge	2850 to 3350	20850(2510.0MHz), +21048(2529.8MHz), 21350(2560.0MHz), +21152(2540.2MHz)	20MHz	QPSK	1 RB / 0 RB Offset 100 RB / 0 RB Offset
-	Peak To Average Ratio	2850 to 3350	20850(2510.0MHz), +21048(2529.8MHz), 21100(2535.0MHz), +21298(2554.8MHz), 21350(2560.0MHz), +21152(2540.2MHz)	20MHz	QPSK / 16QAM / 64QAM	1 RB / 0 RB Offset
-	Conducted Emission	2850 to 3350	20850(2510.0MHz), +21048(2529.8MHz), 21100(2535.0MHz), +21298(2554.8MHz), 21350(2560.0MHz), +21152(2540.2MHz)	20MHz	QPSK	100 RB / 0 RB Offset
-	Radiated Emission Below 1GHz	2850 to 3350	20850(2510.0MHz), +21048(2529.8MHz), 21100(2535.0MHz), +21298(2554.8MHz), 21350(2560.0MHz), +21152(2540.2MHz)	20MHz	QPSK	1 RB / 0 RB Offset
-	Radiated Emission Above 1GHz	2850 to 3350	20850(2510.0MHz), +21048(2529.8MHz), 21100(2535.0MHz), +21298(2554.8MHz), 21350(2560.0MHz), +21152(2540.2MHz)	20MHz	QPSK	1 RB / 0 RB Offset

*After pre-tested all the modes and found 20+20MHz was the worst for bandwidths and power. Therefore only 20+20MHz was for the final test and presented in the test report.

LTE Band 12

EUT Configure Mode	Test item	Available channel	Tested channel	Channel Bandwidth	Modulation	Mode
-	EIRP	23017 to 23171	23017(699.7MHz), 23095(707.5MHz), 23173(715.3MHz)	1.4MHz	QPSK / 16QAM / 64QAM	1 RB / 0 RB Offset
		23025 to 23165	23025(700.5MHz), 23095(707.5MHz), 23165(714.5MHz)	3MHz	QPSK / 16QAM / 64QAM	1 RB / 0 RB Offset
		23035 to 23155	23035(701.5MHz), 23095(707.5MHz), 23155(713.5MHz)	5MHz	QPSK / 16QAM / 64QAM	1 RB / 0 RB Offset
		23060 to 23130	23060(704.0MHz), 23095(707.5 MHz), 23130(711.0 MHz)	10MHz	QPSK / 16QAM / 64QAM	1 RB / 0 RB Offset
-	Modulation Characteristics	23017 to 23171	23095(707.5MHz)	1.4MHz	QPSK / 16QAM	1 RB / 0 RB Offset
		23060 to 23130	23095(707.5MHz)	10MHz	QPSK / 16QAM	1 RB / 0 RB Offset
-	Frequency Stability	23017 to 23171	23017(699.7MHz), 23095(707.5MHz), 23173(715.3MHz)	1.4MHz	QPSK	1 RB / 0 RB Offset
		23025 to 23165	23025(700.5MHz), 23095(707.5MHz), 23165(714.5MHz)	3MHz	QPSK	1 RB / 0 RB Offset
		23035 to 23155	23035(701.5MHz), 23095(707.5MHz), 23155(713.5MHz)	5MHz	QPSK	1 RB / 0 RB Offset
		23060 to 23130	23060(704.0MHz), 23095(707.5MHz), 23130(711.0MHz)	10MHz	QPSK	1 RB / 0 RB Offset
-	Emission Bandwidth	23017 to 23171	23017(699.7MHz), 23095(707.5MHz), 23173(715.3MHz)	1.4MHz	QPSK / 16QAM / 64QAM	6 RB / 0 RB Offset
		23025 to 23165	23025(700.5MHz), 23095(707.5MHz), 23165(714.5MHz)	3MHz	QPSK / 16QAM / 64QAM	15 RB / 0 RB Offset
		23035 to 23155	23035(701.5MHz), 23095(707.5MHz), 23155(713.5MHz)	5MHz	QPSK / 16QAM / 64QAM	25 RB / 0 RB Offset
		23060 to 23130	23060(704.0MHz), 23095(707.5MHz), 23130(711.0MHz)	10MHz	QPSK / 16QAM / 64QAM	50 RB / 0 RB Offset
-	Band Edge	23017 to 23171	23017(699.7MHz)	1.4MHz	QPSK	1 RB / 0 RB Offset 6 RB / 0 RB Offset
			23173(715.3MHz)	1.4MHz	QPSK	1 RB / 5 RB Offset 6 RB / 0 RB Offset
		23025 to 23165	23025(700.5MHz)	3MHz	QPSK	1 RB / 0 RB Offset 15 RB / 0 RB Offset
			23165(714.5MHz)	3MHz	QPSK	1 RB / 14 RB Offset 15 RB / 0 RB Offset
		23035 to 23155	23035(701.5MHz)	5MHz	QPSK	1 RB / 0 RB Offset 25 RB / 0 RB Offset
			23155(713.5MHz)	5MHz	QPSK	1 RB / 24 RB Offset 25 RB / 0 RB Offset
		23060 to 23130	23060(704.0MHz)	10MHz	QPSK	1 RB / 0 RB Offset 50 RB / 0 RB Offset
			23130(711.0MHz)	10MHz	QPSK	1 RB / 49 RB Offset 50 RB / 0 RB Offset

EUT Configure Mode	Test item	Available channel	Tested channel	Channel Bandwidth	Modulation	Mode
-	Peak to Average Ratio	23017 to 23171	23017(699.7MHz), 23095(707.5MHz), 23173(715.3MHz)	1.4MHz	QPSK / 16QAM / 64QAM	1 RB / 0 RB Offset
		23025 to 23165	23025(700.5MHz), 23095(707.5MHz), 23165(714.5MHz)	3MHz	QPSK / 16QAM / 64QAM	1 RB / 0 RB Offset
		23035 to 23155	23035(701.5MHz), 23095(707.5MHz), 23155(713.5MHz)	5MHz	QPSK / 16QAM / 64QAM	1 RB / 0 RB Offset
		23060 to 23130	23060(704.0MHz), 23095(707.5MHz), 23130(711.0MHz)	10MHz	QPSK / 16QAM / 64QAM	1 RB / 0 RB Offset
-	Conducted Emission	23017 to 23171	23017(699.7MHz), 23095(707.5MHz), 23173(715.3MHz)	1.4MHz	QPSK	6 RB / 0 RB Offset
		23025 to 23165	23025(700.5MHz), 23095(707.5MHz), 23165(714.5MHz)	3MHz	QPSK	15 RB / 0 RB Offset
		23035 to 23155	23035(701.5MHz), 23095(707.5MHz), 23155(713.5MHz)	5MHz	QPSK	25 RB / 0 RB Offset
		23060 to 23130	23060(704.0MHz), 23095(707.5MHz), 23130(711.0MHz)	10MHz	QPSK	50 RB / 0 RB Offset
-	Radiated Emission Below 1GHz	23017 to 23171	23017(699.7MHz)	1.4MHz	QPSK	1 RB / 0 RB Offset
		23025 to 23165	23025(700.5MHz)	3MHz	QPSK	1 RB / 0 RB Offset
		23035 to 23155	23035(701.5MHz)	5MHz	QPSK	1 RB / 0 RB Offset
		23060 to 23130	23060(704.0MHz)	10MHz	QPSK	1 RB / 0 RB Offset
-	Radiated Emission Above 1GHz	23017 to 23171	23017(699.7MHz), 23095(707.5MHz), 23173(715.3MHz)	1.4MHz	QPSK	1 RB / 0 RB Offset
		23025 to 23165	23025(700.5MHz), 23095(707.5MHz), 23165(714.5MHz)	3MHz	QPSK	1 RB / 0 RB Offset
		23035 to 23155	23035(701.5MHz), 23095(707.5MHz), 23155(713.5MHz)	5MHz	QPSK	1 RB / 0 RB Offset
		23060 to 23130	23060(704.0MHz), 23095(707.5MHz), 23130(711.0MHz)	10MHz	QPSK	1 RB / 0 RB Offset

LTE Band 13

EUT Configure Mode	Test item	Available channel	Tested channel	Channel Bandwidth	Modulation	Mode
-	EIRP	23205 to 23255	23205(779.5MHz), 23230(782.0MHz), 23255(784.5MHz)	5MHz	QPSK / 16QAM / 64QAM	1 RB / 0 RB Offset
		23230	23230(782.0MHz)	10MHz	QPSK / 16QAM / 64QAM	1 RB / 0 RB Offset
-	Modulation Characteristics	23205 to 23255	23230(782.0MHz),	5MHz	QPSK / 16QAM	1 RB / 0 RB Offset
		23230	23230(782.0MHz),	10MHz	QPSK / 16QAM	1 RB / 0 RB Offset
-	Frequency Stability	23205 to 23255	23230(782.0MHz)	5MHz	QPSK	1 RB / 0 RB Offset
-	Emission Bandwidth	23205 to 23255	23205(779.5MHz), 23230(782.0MHz), 23255(784.5MHz)	5MHz	QPSK / 16QAM / 64QAM	25 RB / 0 RB Offset
		23230	23230(782.0MHz)	10MHz	QPSK / 16QAM / 64QAM	50 RB / 0 RB Offset
-	Band Edge	23205 to 23255	23205(779.5MHz), 23255(784.5MHz)	5MHz	QPSK	1 RB / 0 RB Offset 1 RB / 24 RB Offset 25 RB / 0 RB Offset
		23230	23230(782.0MHz)	10MHz	QPSK	1 RB / 0 RB Offset 1 RB / 49 RB Offset 50 RB / 0 RB Offset
-	Peak to Average Ratio	23205 to 23255	23205(779.5MHz), 23230(782.0MHz), 23255(784.5MHz)	5MHz	QPSK / 16QAM / 64QAM	25 RB / 0 RB Offset
		23230	23230(782.0MHz)	10MHz	QPSK / 16QAM / 64QAM	50 RB / 0 RB Offset
-	Conducted Emission	23205 to 23255	23205(779.5MHz), 23230(782.0MHz), 23255(784.5MHz)	5MHz	QPSK	1 RB / 0 RB Offset
		23230	23230(782.0MHz)	10MHz	QPSK	1 RB / 0 RB Offset
-	Radiated Emission Below 1GHz	23205 to 23255	23205(779.5MHz)	5MHz	QPSK	1 RB / 0 RB Offset
		23230	23230(782.0MHz)	10MHz	QPSK	1 RB / 0 RB Offset
-	Radiated Emission Above 1GHz	23205 to 23255	23205(779.5MHz), 23230(782.0MHz), 23255(784.5MHz)	5MHz	QPSK	1 RB / 0 RB Offset
		23230	23230(782.0MHz)	10MHz	QPSK	1 RB / 0 RB Offset

LTE Band 17

EUT Configure Mode	Test item	Available channel	Tested channel	Channel Bandwidth	Modulation	Mode
-	EIRP	23755 to 23825	23755(706.5MHz), 23790(710.0MHz), 23825(713.5MHz)	5MHz	QPSK / 16QAM / 64QAM	1 RB / 0 RB Offset
		23780 to 23800	23780(709.0MHz), 23790(710.0MHz), 23800(711.0MHz)	10MHz	QPSK / 16QAM / 64QAM	1 RB / 0 RB Offset
-	Modulation Characteristics	23755 to 23825	23790(710.0MHz)	5MHz	QPSK / 16QAM	1 RB / 0 RB Offset
		23780 to 23800	23790(710.0MHz)	10MHz	QPSK / 16QAM	1 RB / 0 RB Offset
-	Frequency Stability	23755 to 23825	23790(710.0MHz)	5MHz	QPSK	1 RB / 0 RB Offset
-	Emission Bandwidth	23755 to 23825	23755(706.5MHz), 23790(710.0MHz), 23825(713.5MHz)	5MHz	QPSK / 16QAM / 64QAM	25 RB / 0 RB Offset
		23780 to 23800	23780(709.0MHz), 23790(710.0MHz), 23800(711.0MHz)	10MHz	QPSK / 16QAM / 64QAM	50 RB / 0 RB Offset
-	Band Edge	23755 to 23825	23755(706.5MHz), 23825(713.5MHz)	5MHz	QPSK	1 RB / 0 RB Offset 1 RB / 24 RB Offset 25 RB / 0 RB Offset
		23780 to 23800	23780(709.0MHz), 23800(711.0MHz)	10MHz	QPSK	1 RB / 0 RB Offset 1 RB / 49 RB Offset 50 RB / 0 RB Offset
-	Peak to Average Ratio	23205 to 23255	23205(779.5MHz), 23230(782.0MHz), 23255(784.5MHz)	5MHz	QPSK / 16QAM / 64QAM	25 RB / 0 RB Offset
		23230	23230(782.0MHz)	10MHz	QPSK / 16QAM / 64QAM	50 RB / 0 RB Offset
-	Conducted Emission	23755 to 23825	23755(706.5MHz), 23790(710.0MHz), 23825(713.5MHz)	5MHz	QPSK	1 RB / 0 RB Offset
		23780 to 23800	23780(709.0MHz), 23790(710.0MHz), 23800(711.0MHz)	10MHz	QPSK	1 RB / 0 RB Offset
-	Radiated Emission Below 1GHz	23755 to 23825	23755(706.5MHz)	5MHz	QPSK	1 RB / 0 RB Offset
		23780 to 23800	23780(710.0MHz)	10MHz	QPSK	1 RB / 0 RB Offset
-	Radiated Emission Above 1GHz	23755 to 23825	23755(706.5MHz), 23790(710.0MHz), 23825(713.5MHz)	5MHz	QPSK	1 RB / 0 RB Offset
		23780 to 23800	23780(709.0MHz), 23790(710.0MHz), 23800(711.0MHz)	10MHz	QPSK	1 RB / 0 RB Offset

LTE Band 38

EUT Configure Mode	Test item	Available channel	Tested channel	Channel Bandwidth	Modulation	Mode
-	EIRP	37775 to 38225	37775(2572.5MHz), 38000(2595.0MHz), 38225(2617.5MHz)	5MHz	QPSK / 16QAM / 64QAM	1 RB / 0 RB Offset
		37800 to 38200	37800(2575.0MHz), 38000(2595.0MHz), 38200(2615.0MHz)	10MHz	QPSK / 16QAM / 64QAM	1 RB / 0 RB Offset
		37825 to 38175	37825(2577.5MHz), 38000(2595.0MHz), 38175(2612.5MHz)	15MHz	QPSK / 16QAM / 64QAM	1 RB / 0 RB Offset
		37850 to 38150	37850(2580.0MHz), 38000(2595.0MHz), 38150(2610.0MHz)	20MHz	QPSK / 16QAM / 64QAM	1 RB / 0 RB Offset
-	Modulation Characteristics	37775 to 38225	38000(2595.0MHz)	5MHz	QPSK / 16QAM	1 RB / 0 RB Offset
		37850 to 38150	38000(2595.0MHz)	20MHz	QPSK / 16QAM	1 RB / 0 RB Offset
-	Frequency Stability	37775 to 38225	38000(2595.0MHz)	5MHz	QPSK	1 RB / 0 RB Offset
		37800 to 38200	38000(2595.0MHz)	10MHz	QPSK	1 RB / 0 RB Offset
		37825 to 38175	38000(2595.0MHz)	15MHz	QPSK	1 RB / 0 RB Offset
		37850 to 38150	38000(2595.0MHz)	20MHz	QPSK	1 RB / 0 RB Offset
-	Emission Bandwidth	37775 to 38225	37775(2572.5MHz), 38000(2595.0MHz), 38225(2617.5MHz)	5MHz	QPSK / 16QAM / 64QAM	1 RB / 0 RB Offset
		37800 to 38200	37800(2575.0MHz), 38000(2595.0MHz), 38200(2615.0MHz)	10MHz	QPSK / 16QAM / 64QAM	1 RB / 0 RB Offset
		37825 to 38175	37825(2577.5MHz), 38000(2595.0MHz), 38175(2612.5MHz)	15MHz	QPSK / 16QAM / 64QAM	1 RB / 0 RB Offset
		37850 to 38150	37850(2580.0MHz), 38000(2595.0MHz), 38150(2610.0MHz)	20MHz	QPSK / 16QAM / 64QAM	1 RB / 0 RB Offset
-	Band Edge	37775 to 38225	37775(2572.5MHz), 38225(2617.5MHz)	5MHz	QPSK	1 RB / 0 RB Offset 1 RB / 24 RB Offset 25 RB / 0 RB Offset
		37800 to 38200	37800(2575.0MHz), 38200(2615.0MHz)	10MHz	QPSK	1 RB / 0 RB Offset 1 RB / 49 RB Offset 50 RB / 0 RB Offset
		37825 to 38175	37825(2577.5MHz), 38175(2612.5MHz)	15MHz	QPSK	1 RB / 0 RB Offset 1 RB / 74 RB Offset 75 RB / 0 RB Offset
		37850 to 38150	37850(2580.0MHz), 38150(2610.0MHz)	20MHz	QPSK	1 RB / 0 RB Offset 1 RB / 99 RB Offset 100 RB / 0 RB Offset
-	Conducted Emission	37775 to 38225	37775(2572.5MHz), 38000(2595.0MHz), 38225(2617.5MHz)	5MHz	QPSK	1 RB / 0 RB Offset
		37800 to 38200	37800(2575.0MHz), 38000(2595.0MHz), 38200(2615.0MHz)	10MHz	QPSK	1 RB / 0 RB Offset
		37825 to 38175	37825(2577.5MHz), 38000(2595.0MHz), 38175(2612.5MHz)	15MHz	QPSK	1 RB / 0 RB Offset
		37850 to 38150	37850(2580.0MHz), 38000(2595.0MHz), 38150(2610.0MHz)	20MHz	QPSK	1 RB / 0 RB Offset

EUT Configure Mode	Test item	Available channel	Tested channel	Channel Bandwidth	Modulation	Mode
-	Radiated Emission Below 1GHz	37775 to 38225	37775(2572.5MHz)	5MHz	QPSK	1 RB / 0 RB Offset
		37800 to 38200	37800(2575.0MHz)	10MHz	QPSK	1 RB / 0 RB Offset
		37825 to 38175	37825(2577.5MHz)	15MHz	QPSK	1 RB / 0 RB Offset
		37850 to 38150	37850(2580.0MHz)	20MHz	QPSK	1 RB / 0 RB Offset
-	Radiated Emission Above 1GHz	37775 to 38225	37775(2572.5MHz), 38000(2595.0MHz), 38225(2617.5MHz)	5MHz	QPSK	1 RB / 0 RB Offset
		37800 to 38200	37800(2575.0MHz), 38000(2595.0MHz), 38200(2615.0MHz)	10MHz	QPSK	1 RB / 0 RB Offset
		37825 to 38175	37825(2577.5MHz), 38000(2595.0MHz), 38175(2612.5MHz)	15MHz	QPSK	1 RB / 0 RB Offset
		37850 to 38150	37850(2580.0MHz), 38000(2595.0MHz), 38150(2610.0MHz)	20MHz	QPSK	1 RB / 0 RB Offset

LTE Band 41

EUT Configure Mode	Test item	Available channel	Tested channel	Channel Bandwidth	Modulation	Mode
-	EIRP	40065 to 41215	40065(2537.5MHz), 40640(2595.0MHz), 41215(2652.5MHz)	5MHz	QPSK / 16QAM / 64QAM	1 RB / 0 RB Offset
		40090 to 41190	40090(2540.0MHz), 40640(2595.0MHz), 41190(2650.0MHz)	10MHz	QPSK / 16QAM / 64QAM	1 RB / 0 RB Offset
		40115 to 41165	40115(2542.5MHz), 40640(2595.0MHz), 41165(2647.5MHz)	15MHz	QPSK / 16QAM / 64QAM	1 RB / 0 RB Offset
		40140 to 41140	40140(2545.0MHz), 40640(2595.0MHz), 41140(2645.0MHz)	20MHz	QPSK / 16QAM / 64QAM	1 RB / 0 RB Offset
-	Modulation Characteristics	40140 to 41140	40640(2595.0MHz)	20MHz	QPSK / 16QAM	1 RB / 0 RB Offset
-	Frequency Stability	40065 to 41215	40640(2595.0MHz)	5MHz	QPSK	1 RB / 0 RB Offset
		40090 to 41190	40640(2595.0MHz)	10MHz	QPSK	1 RB / 0 RB Offset
		40115 to 41165	40640(2595.0MHz)	15MHz	QPSK	1 RB / 0 RB Offset
		40140 to 41140	40640(2595.0MHz)	20MHz	QPSK	1 RB / 0 RB Offset
-	Emission Bandwidth	40065 to 41215	40065(2537.5MHz), 40640(2595.0MHz), 41215(2652.5MHz)	5MHz	QPSK / 16QAM / 64QAM	1 RB / 0 RB Offset
		40090 to 41190	40090(2540.0MHz), 40640(2595.0MHz), 41190(2650.0MHz)	10MHz	QPSK / 16QAM / 64QAM	1 RB / 0 RB Offset
		40115 to 41165	40115(2542.5MHz), 40640(2595.0MHz), 41165(2647.5MHz)	15MHz	QPSK / 16QAM / 64QAM	1 RB / 0 RB Offset
		40140 to 41140	40140(2545.0MHz), 40640(2595.0MHz), 41140(2645.0MHz)	20MHz	QPSK / 16QAM / 64QAM	1 RB / 0 RB Offset
-	Band Edge	40065 to 41215	40065(2537.5MHz), 41215(2652.5MHz)	5MHz	QPSK	1 RB / 0 RB Offset 1 RB / 24 RB Offset 25 RB / 0 RB Offset
		40090 to 41190	40090(2540.0MHz), 41190(2650.0MHz)	10MHz	QPSK	1 RB / 0 RB Offset 1 RB / 49 RB Offset 50 RB / 0 RB Offset
		40115 to 41165	40115(2542.5MHz), 41165(2647.5MHz)	15MHz	QPSK	1 RB / 0 RB Offset 1 RB / 74 RB Offset 75 RB / 0 RB Offset
		40140 to 41140	40140(2545.0MHz), 41140(2645.0MHz)	20MHz	QPSK	1 RB / 0 RB Offset 1 RB / 99 RB Offset 100 RB / 0 RB Offset
-	Conducted Emission	40065 to 41215	40065(2537.5MHz), 40640(2595.0MHz), 41215(2652.5MHz)	5MHz	QPSK	1 RB / 0 RB Offset
		40090 to 41190	40090(2540.0MHz), 40640(2595.0MHz), 41190(2650.0MHz)	10MHz	QPSK	1 RB / 0 RB Offset
		40115 to 41165	40115(2542.5MHz), 40640(2595.0MHz), 41165(2647.5MHz)	15MHz	QPSK	1 RB / 0 RB Offset
		40140 to 41140	40140(2545.0MHz), 40640(2595.0MHz), 41140(2645.0MHz)	20MHz	QPSK	1 RB / 0 RB Offset

EUT Configure Mode	Test item	Available channel	Tested channel	Channel Bandwidth	Modulation	Mode
-	Radiated Emission Below 1GHz	40065 to 41215	40065(2537.5MHz)	5MHz	QPSK	1 RB / 0 RB Offset
		40090 to 41190	40090(2540.0MHz)	10MHz	QPSK	1 RB / 0 RB Offset
		40115 to 41165	40115(2542.5MHz)	15MHz	QPSK	1 RB / 0 RB Offset
		40140 to 41140	40140(2545.0MHz)	20MHz	QPSK	1 RB / 0 RB Offset
-	Radiated Emission Above 1GHz	40065 to 41215	40065(2537.5MHz), 40640(2595.0MHz), 41215(2652.5MHz)	5MHz	QPSK	1 RB / 0 RB Offset
		40090 to 41190	40090(2540.0MHz), 40640(2595.0MHz), 41190(2650.0MHz)	10MHz	QPSK	1 RB / 0 RB Offset
		40115 to 41165	40115(2542.5MHz), 40640(2595.0MHz), 41165(2647.5MHz)	15MHz	QPSK	1 RB / 0 RB Offset
		40140 to 41140	40140(2545.0MHz), 40640(2595.0MHz), 41140(2645.0MHz)	20MHz	QPSK	1 RB / 0 RB Offset

LTE Band 66

EUT Configure Mode	Test Item	Available Channel	Tested Channel	Channel Bandwidth	Modulation	Mode
-	EIRP	131979 to 132665	131979(1710.7MHz) 132322(1745.0MHz) 132665(1779.3MHz)	1.4MHz	QPSK / 16QAM / 64QAM	1 RB / 0 RB Offset
		131987 to 132657	131987(1711.5MHz) 132322(1745.0MHz) 132657(1778.5MHz)	3MHz	QPSK / 16QAM / 64QAM	1 RB / 0 RB Offset
		131997 to 132647	131997(1712.5MHz) 132322(1745.0MHz) 132647(1777.5MHz)	5MHz	QPSK / 16QAM / 64QAM	1 RB / 0 RB Offset
		132022 to 132622	132022(1715.0MHz) 132322(1745.0MHz) 132622(1775.0MHz)	10MHz	QPSK / 16QAM / 64QAM	1 RB / 0 RB Offset
		132047 to 132597	132047(1717.5MHz) 132322(1745.0MHz) 132597(1772.5MHz)	15MHz	QPSK / 16QAM / 64QAM	1 RB / 0 RB Offset
		132072 to 132572	132072(1720.0MHz) 132322(1745.0MHz) 132572(1770.0MHz)	20MHz	QPSK / 16QAM / 64QAM	1 RB / 0 RB Offset
-	Modulation Characteristics	131979 to 132665	132322(1745.0MHz)	1.4MHz	QPSK / 16QAM	1 RB / 0 RB Offset
		132072 to 132572	132322(1745.0MHz)	20MHz	QPSK / 16QAM	1 RB / 0 RB Offset
-	Frequency Stability	131979 to 132665	132322(1745.0MHz)	1.4MHz	QPSK	1 RB / 0 RB Offset
-	Emission Bandwidth	131979 to 132665	131979(1710.7MHz) 132322(1745.0MHz) 132665(1779.3MHz)	1.4MHz	QPSK / 16QAM / 64QAM	6 RB / 0 RB Offset
		131987 to 132657	131987(1711.5MHz) 132322(1745.0MHz) 132657(1778.5MHz)	3MHz	QPSK / 16QAM / 64QAM	15 RB / 0 RB Offset
		131997 to 132647	131997(1712.5MHz) 132322(1745.0MHz) 132647(1777.5MHz)	5MHz	QPSK / 16QAM / 64QAM	25 RB / 0 RB Offset
		132022 to 132622	132022(1715.0MHz) 132322(1745.0MHz) 132622(1775.0MHz)	10MHz	QPSK / 16QAM / 64QAM	50 RB / 0 RB Offset
		132047 to 132597	132047(1717.5MHz) 132322(1745.0MHz) 132597(1772.5MHz)	15MHz	QPSK / 16QAM / 64QAM	75 RB / 0 RB Offset
		132072 to 132572	132072(1720.0MHz) 132322(1745.0MHz) 132572(1770.0MHz)	20MHz	QPSK / 16QAM / 64QAM	100 RB / 0 RB Offset
-	Channel Edge	131979 to 132665	131979(1710.7MHz) 132665(1779.3MHz)	1.4MHz	QPSK	1 RB / 0 RB Offset 1 RB / 5 RB Offset 6 RB / 0 RB Offset
		131987 to 132657	131987(1711.5MHz) 132657(1778.5MHz)	3MHz	QPSK	1 RB / 0 RB Offset 1 RB / 14 RB Offset 15 RB / 0 RB Offset
		131997 to 132647	131997(1712.5MHz) 132647(1777.5MHz)	5MHz	QPSK	1 RB / 0 RB Offset 1 RB / 24 RB Offset 25 RB / 0 RB Offset
		132022 to 132622	132022(1715.0MHz) 132622(1775.0MHz)	10MHz	QPSK	1 RB / 0 RB Offset 1 RB / 49 RB Offset 50 RB / 0 RB Offset
		132047 to 132597	132047(1717.5MHz) 132597(1772.5MHz)	15MHz	QPSK	1 RB / 0 RB Offset 1 RB / 74 RB Offset 75 RB / 0 RB Offset
		132072 to 132572	132072(1720.0MHz) 132572(1770.0MHz)	20MHz	QPSK	1 RB / 0 RB Offset 1 RB / 99 RB Offset 100 RB / 0 RB Offset

EUT Configure Mode	Test Item	Available Channel	Tested Channel	Channel Bandwidth	Modulation	Mode
-	Conducted Emission	131979 to 132665	131979(1710.7MHz) 132665(1779.3MHz)	1.4MHz	QPSK	1 RB / 0 RB Offset
		131987 to 132657	131987(1711.5MHz) 132657(1778.5MHz)	3MHz	QPSK	1 RB / 0 RB Offset
		131997 to 132647	131997(1712.5MHz) 132647(1777.5MHz)	5MHz	QPSK	1 RB / 0 RB Offset
		132022 to 132622	132022(1715.0MHz) 132622(1775.0MHz)	10MHz	QPSK	1 RB / 0 RB Offset
		132047 to 132597	132047(1717.5MHz) 132597(1772.5MHz)	15MHz	QPSK	1 RB / 0 RB Offset
		132072 to 132572	132072(1720.0MHz) 132572(1770.0MHz)	20MHz	QPSK	1 RB / 0 RB Offset
-	Radiated Emission Below 1GHz	131979 to 132665	131979(1710.7MHz)	1.4MHz	QPSK	1 RB / 0 RB Offset
		131987 to 132657	131987(1711.5MHz)	3MHz	QPSK	1 RB / 0 RB Offset
		131997 to 132647	131997(1712.5MHz)	5MHz	QPSK	1 RB / 0 RB Offset
		132022 to 132622	132022(1715.0MHz)	10MHz	QPSK	1 RB / 0 RB Offset
		132047 to 132597	132047(1717.5MHz)	15MHz	QPSK	1 RB / 0 RB Offset
		132072 to 132572	132072(1720.0MHz)	20MHz	QPSK	1 RB / 0 RB Offset
-	Radiated Emission Above 1GHz	131979 to 132665	131979(1710.7MHz) 132322(1745.0MHz) 132665(1779.3MHz)	1.4MHz	QPSK	1 RB / 0 RB Offset
		131987 to 132657	131987(1711.5MHz) 132322(1745.0MHz) 132657(1778.5MHz)	3MHz	QPSK	1 RB / 0 RB Offset
		131997 to 132647	131997(1712.5MHz) 132322(1745.0MHz) 132647(1777.5MHz)	5MHz	QPSK	1 RB / 0 RB Offset
		132022 to 132622	132022(1715.0MHz) 132322(1745.0MHz) 132622(1775.0MHz)	10MHz	QPSK	1 RB / 0 RB Offset
		132047 to 132597	132047(1717.5MHz) 132322(1745.0MHz) 132597(1772.5MHz)	15MHz	QPSK	1 RB / 0 RB Offset
		132072 to 132572	132072(1720.0MHz) 132322(1745.0MHz) 132572(1770.0MHz)	20MHz	QPSK	1 RB / 0 RB Offset

CA Mode

EUT Configure Mode	Test Item	Band	Tested Channel	Channel Bandwidth	Modulation	Mode
-	Radiated Emission Above 1GHz	LTE Band 2+ LTE Band 12	18900(1880.00MHz)+ 23095(707.5MHz)	20MHz+20MHz	QPSK	1 RB / 0 RB Offset
		LTE Band 4+ LTE Band 12	20175(1732.5MHz)+ 23095(707.5MHz)	20MHz+10MHz	QPSK	1 RB / 0 RB Offset
		LTE Band 13+ LTE Band 66	23230(782.0MHz)+ 132322(1745.0MHz)	10MHz+20MHz	QPSK	1 RB / 0 RB Offset

Note:

- For radiated emission below 1GHz, low, mid and high channels were pre-tested in chamber with 1.4MHz mode. Low channel on mode A was found to be the worst case and therefore had been chosen for all final tests.
- The conducted output power for QPSK, 16QAM and 64QAM, measured value of QPSK is higher than 16QAM and 64QAM mode. Therefore, only occupied bandwidth and Peak to average ratio items had been tested under QPSK, 16QAM and 64QAM modes, the other test items were performed under QPSK mode only.

Test Condition:

Test Item	Environmental Conditions	Input Power	Tested By
EIRP	22deg. C, 66%RH	120Vac, 60Hz	Han Wu
Modulation characteristics	24deg. C, 64%RH	120Vac, 60Hz	James Yang
Frequency Stability	24deg. C, 64%RH	120Vac, 60Hz	James Yang
Occupied Bandwidth	24deg. C, 64%RH	120Vac, 60Hz	James Yang
Band Edge	24deg. C, 64%RH	120Vac, 60Hz	James Yang
Peak To Average Ratio	24deg. C, 64%RH	120Vac, 60Hz	James Yang
Conducted Emission	24deg. C, 64%RH	120Vac, 60Hz	James Yang
Radiated Emission	22deg. C, 66%RH 25deg. C, 65%RH	120Vac, 60Hz	Han Wu Greg Lin

3.4 EUT Operating Conditions

The EUT makes a call to the communication simulator. The communication simulator station system controlled a EUT to export maximum output power under transmission mode and specific channel frequency

3.5 General Description of Applied Standards

The EUT is a RF Product. According to the specifications of the manufacturer, it must comply with the requirements of the following standards:

FCC 47 CFR Part 2

FCC 47 CFR Part 27

KDB 971168 D01 Power Meas License Digital Systems v03r01

ANSI/TIA/EIA-603-E 2016

ANSI 63.26-2015

Note: All test items have been performed and recorded as per the above standards.

4 Test Types and Results

4.1 Output Power Measurement

4.1.1 Limits of Output Power Measurement

Mobile / Portable station are limited to 1 watts e.i.r.p for WCDMA, LTE Band 4 & LTE Band 66, 2 watts e.r.p. for LTE Band 7, Band 38, Band 41 and 3 watts e.r.p for LTE Band 12, Band 13 & Band 17.

4.1.2 Test Procedures

EIRP / ERP Measurement:

- a. All measurements were done at low, middle and high operational frequency range. RWB and VBW is 5MHz for WCDMA mode and 5MHz for LTE Mode.
- b. Substitution method is used for E.I.R.P measurement. In the semi-anechoic chamber, EUT placed on the 0.8m(below or equal 1GHz) and/or 1.5m(above 1GHz) height of Turn Table, rotated the table around 360 degrees to search the maximum radiation power and receiver antenna shall be rotated vertical and horizontal polarization and moved height from 1m to 4m to find the maximum polar radiated power. The "Read Value" is the spectrum reading the maximum power value.
- c. The substitution horn antenna is substituted for EUT at the same position and signals generator export the CW signal to the substitution antenna via a TX cable. Rotated the Turn Table and moved receiving antenna to find the maximum radiation power. Adjust output power level of S.G to get a Value of spectrum reading equal to "Read Value" of step b. Record the power level of S.G
- d. $EIRP = \text{Output power level of S.G} - \text{TX cable loss} + \text{Antenna gain of substitution horn.}$ E.R.P power can be calculated form E.I.R.P power by subtracting the gain of dipole, $E.R.P \text{ power} = E.I.R.P \text{ power} - 2.15\text{dBi.}$

Conducted Power Measurement:

A power sensor was used on the output port of the EUT. A power meter was used to read the response of the power sensor. Record the power level.

4.1.3 Test Setup

EIRP / ERP MEASUREMENT:

For Radiated Emission below or equal 1GHz

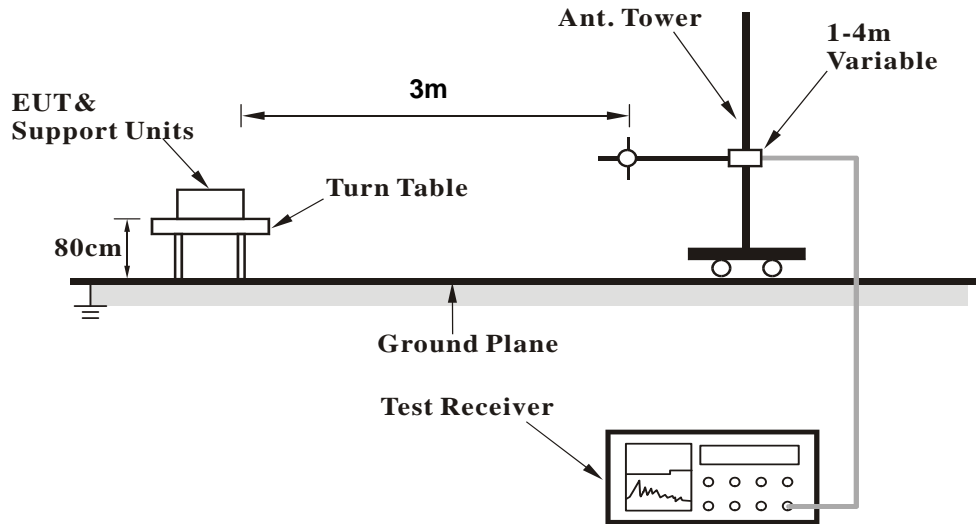

For Radiated Emission above 1GHz

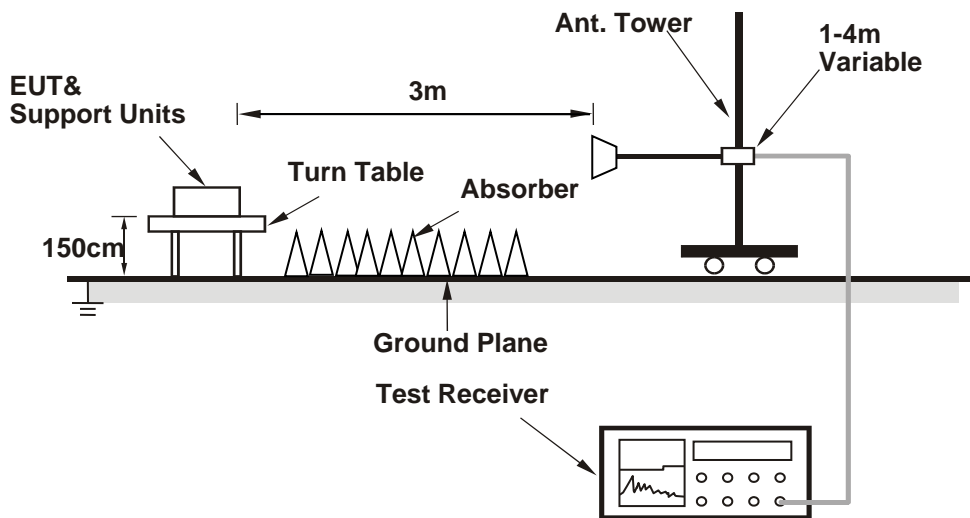

For the actual test configuration, please refer to the attached file (Test Setup Photo).

CONDUCTED POWER MEASUREMENT:

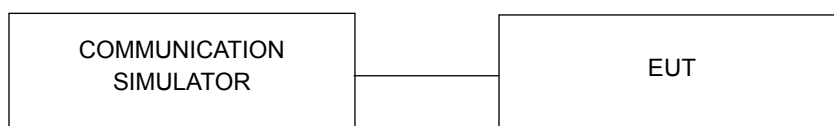

For the actual test configuration, please refer to the attached file (Test Setup Photo).

4.1.4 Test Results

CONDUCTED OUTPUT POWER (dBm)

Band	WCDMA Band IV		
	1312	1413	1513
TX Channel	1312	1413	1513
Rx Channel	1537	1638	1738
Frequency (MHz)	1712.4	1732.6	1752.6
RMC 12.2K	22.94	23.03	22.89
HSDPA Subtest-1	21.89	21.98	21.84
HSDPA Subtest-2	21.86	21.95	21.81
HSDPA Subtest-3	21.34	21.43	21.29
HSDPA Subtest-4	21.32	21.41	21.27
DC-HSDPA Subtest-1	21.87	21.94	21.82
DC-HSDPA Subtest-2	21.82	21.88	21.75
DC-HSDPA Subtest-3	21.36	21.39	21.28
DC-HSDPA Subtest-4	21.32	21.38	21.23
HSUPA Subtest-1	21.88	21.97	21.83
HSUPA Subtest-2	19.87	19.96	19.82
HSUPA Subtest-3	20.85	20.94	20.80
HSUPA Subtest-4	19.89	19.98	19.84
HSUPA Subtest-5	21.91	22.00	21.86

Conducted Output Power (dBm)
 LTE Band 4

LTE Band 4						
BW	MCS Index	RB Size	RB Offset	Low	Mid	High
		Channel		20050	20175	20300
		Frequency (MHz)		1720	1732.5	1745
20M	QPSK	1	0	22.64	22.69	22.63
		1	50	22.34	22.39	22.33
		1	99	22.26	22.31	22.25
		50	0	21.51	21.56	21.50
		50	25	21.42	21.47	21.41
		50	50	21.33	21.38	21.32
		100	0	21.41	21.46	21.40
	16QAM	1	0	21.54	21.65	21.58
		1	50	21.29	21.37	21.27
		1	99	21.19	21.31	21.18
		50	0	20.49	20.56	20.42
		50	25	20.36	20.38	20.40
		50	50	20.31	20.29	20.32
		100	0	20.36	20.43	20.35
	64QAM	1	0	20.54	20.69	20.55
		1	50	20.34	20.37	20.31
		1	99	20.23	20.23	20.24
		50	0	19.43	19.50	19.50
		50	25	19.33	19.46	19.38
		50	50	19.32	19.29	19.28
		100	0	19.41	19.40	19.33

LTE Band 4						
BW	MCS Index	RB Size	RB Offset	Low	Mid	High
		Channel		20025	20175	20325
		Frequency (MHz)		1717.5	1732.5	1747.5
15M	QPSK	1	0	22.57	22.61	22.57
		1	37	22.27	22.30	22.33
		1	74	22.18	22.26	22.19
		36	0	21.45	21.48	21.45
		36	19	21.33	21.41	21.36
		36	39	21.24	21.32	21.32
		75	0	21.31	21.46	21.33
	16QAM	1	0	21.58	21.51	21.48
		1	37	21.31	21.28	21.21
		1	74	21.24	21.19	21.15
		36	0	20.46	20.41	20.46
		36	19	20.31	20.42	20.27
		36	39	20.15	20.32	20.23
		75	0	20.32	20.30	20.31
	64QAM	1	0	20.50	20.61	20.44
		1	37	20.24	20.29	20.26
		1	74	20.20	20.12	20.07
		36	0	19.32	19.53	19.40
		36	19	19.37	19.29	19.30
		36	39	19.22	19.20	19.16
		75	0	19.23	19.38	19.31

LTE Band 4						
BW	MCS Index	RB Size	RB Offset	Low	Mid	High
		Channel		20000	20175	20350
		Frequency (MHz)		1715	1732.5	1750
10M	QPSK	1	0	22.54	22.65	22.52
		1	24	22.21	22.28	22.32
		1	49	22.09	22.24	22.22
		25	0	21.48	21.40	21.35
		25	12	21.31	21.31	21.18
		25	25	21.16	21.29	21.22
		50	0	21.29	21.31	21.29
	16QAM	1	0	21.36	21.61	21.54
		1	24	21.18	21.28	21.08
		1	49	21.04	21.20	21.03
		25	0	20.47	20.37	20.30
		25	12	20.27	20.26	20.27
		25	25	20.32	20.15	20.13
		50	0	20.34	20.26	20.16
	64QAM	1	0	20.55	20.44	20.48
		1	24	20.11	20.21	20.17
		1	49	20.00	20.07	20.07
		25	0	19.33	19.46	19.31
		25	12	19.16	19.24	19.30
		25	25	19.23	19.24	19.03
		50	0	19.17	19.36	19.23

LTE Band 4						
BW	MCS Index	RB Size	RB Offset	Low	Mid	High
		Channel		19975	20175	20375
		Frequency (MHz)		1712.5	1732.5	1752.5
5M	QPSK	1	0	22.60	22.52	22.44
		1	12	22.31	22.23	22.07
		1	24	22.21	22.17	22.07
		12	0	21.36	21.47	21.35
		12	6	21.25	21.30	21.25
		12	13	21.16	21.22	21.15
		25	0	21.28	21.33	21.24
	16QAM	1	0	21.50	21.53	21.61
		1	12	21.03	21.32	21.22
		1	24	21.09	21.14	21.05
		12	0	20.32	20.37	20.39
		12	6	20.20	20.34	20.13
		12	13	20.16	20.25	20.16
		25	0	20.19	20.27	20.23
	64QAM	1	0	20.42	20.61	20.48
		1	12	20.21	20.20	20.14
		1	24	20.13	20.17	20.18
		12	0	19.38	19.38	19.44
		12	6	19.27	19.25	19.23
		12	13	19.20	19.16	19.20
		25	0	19.21	19.17	19.27

LTE Band 4						
BW	MCS Index	RB Size	RB Offset	Low	Mid	High
		Channel		19965	20175	20385
		Frequency (MHz)		1711.5	1732.5	1753.5
3M	QPSK	1	0	22.53	22.61	22.56
		1	7	22.22	22.34	22.17
		1	14	22.19	22.25	22.18
		8	0	21.40	21.34	21.42
		8	3	21.30	21.39	21.27
		8	7	21.13	21.33	21.27
		15	0	21.33	21.35	21.16
	16QAM	1	0	21.30	21.38	21.56
		1	7	21.23	21.31	21.10
		1	14	21.12	21.13	21.05
		8	0	20.31	20.41	20.41
		8	3	20.22	20.44	20.16
		8	7	20.20	20.21	20.25
		15	0	20.24	20.19	20.14
	64QAM	1	0	20.55	20.49	20.36
		1	7	20.03	20.14	20.12
		1	14	20.13	20.19	19.98
		8	0	19.42	19.31	19.37
		8	3	19.25	19.30	19.23
		8	7	19.03	19.21	19.05
		15	0	19.26	19.31	19.16

LTE Band 4						
BW	MCS Index	RB Size	RB Offset	Low	Mid	High
		Channel		19957	20175	20393
		Frequency (MHz)		1710.7	1732.5	1754.3
1.4M	QPSK	1	0	22.47	22.57	22.53
		1	2	22.19	22.25	22.29
		1	5	22.12	22.22	22.18
		3	0	22.41	22.39	22.45
		3	1	22.20	22.39	22.30
		3	3	22.24	22.19	22.18
		6	0	21.40	21.44	21.30
	16QAM	1	0	21.46	21.52	21.44
		1	2	21.18	21.14	21.13
		1	5	21.01	21.12	21.13
		3	0	21.42	21.42	21.42
		3	1	21.24	21.26	21.13
		3	3	21.19	21.17	21.14
		6	0	20.19	20.20	20.31
	64QAM	1	0	20.47	20.63	20.49
		1	2	20.17	20.28	20.14
		1	5	20.04	20.23	20.09
		3	0	20.22	20.45	20.33
		3	1	20.29	20.37	20.23
		3	3	20.31	20.17	20.10
		6	0	19.28	19.25	19.28

LTE Band 7						
BW	MCS Index	RB Size	RB Offset	Low	Mid	High
		Channel		20850	21100	21350
		Frequency (MHz)		2510	2535	2560
20M	QPSK	1	0	21.13	21.17	21.08
		1	50	21.01	21.05	20.96
		1	99	20.97	21.01	20.92
		50	0	20.07	20.11	20.02
		50	25	20.05	20.09	20.00
		50	50	20.02	20.06	19.97
		100	0	20.04	20.08	19.99
	16QAM	1	0	20.13	20.17	20.08
		1	50	19.96	20.04	19.91
		1	99	19.94	19.94	19.86
		50	0	19.07	19.08	18.93
		50	25	19.05	19.03	18.99
		50	50	19.00	19.06	18.89
		100	0	18.99	19.02	18.97
	64QAM	1	0	19.09	19.15	19.00
		1	50	18.91	19.00	18.91
		1	99	18.88	18.96	18.83
		50	0	18.01	18.06	17.98
		50	25	17.97	17.99	17.92
		50	50	17.92	18.02	17.89
		100	0	18.00	18.05	17.91

LTE Band 7						
BW	MCS Index	RB Size	RB Offset	Low	Mid	High
		Channel		20825	21100	21375
		Frequency (MHz)		2507.5	2535	2562.5
15M	QPSK	1	0	21.04	21.15	21.01
		1	37	20.99	21.02	20.86
		1	74	20.91	21.00	20.86
		36	0	20.04	20.09	19.99
		36	19	19.95	20.05	19.98
		36	39	19.94	19.97	19.93
		75	0	20.04	20.05	19.92
	16QAM	1	0	20.00	19.99	19.94
		1	37	19.94	19.91	19.77
		1	74	19.92	19.88	19.85
		36	0	19.01	18.96	18.94
		36	19	18.91	18.96	18.91
		36	39	18.98	18.96	18.78
		75	0	18.90	19.02	18.86
	64QAM	1	0	19.04	19.05	18.98
		1	37	18.98	18.95	18.92
		1	74	18.93	18.89	18.82
		36	0	17.95	17.97	17.93
		36	19	17.94	17.99	17.94
		36	39	17.86	18.00	17.89
		75	0	17.92	17.97	17.88

LTE Band 7						
BW	MCS Index	RB Size	RB Offset	Low	Mid	High
		Channel		20800	21100	21400
		Frequency (MHz)		2505	2535	2565
10M	QPSK	1	0	20.91	21.04	20.96
		1	24	20.83	20.94	20.79
		1	49	20.82	20.84	20.70
		25	0	20.00	20.05	19.92
		25	12	19.84	19.86	19.97
		25	25	19.84	19.92	19.79
		50	0	19.98	19.85	19.83
	16QAM	1	0	19.95	20.05	19.79
		1	24	19.83	19.75	19.83
		1	49	19.83	19.77	19.86
		25	0	18.82	18.93	18.89
		25	12	18.88	18.96	18.72
		25	25	18.87	18.90	18.82
		50	0	18.80	18.90	18.82
	64QAM	1	0	19.00	18.99	18.88
		1	24	18.69	18.77	18.73
		1	49	18.84	18.79	18.82
		25	0	17.96	17.88	17.83
		25	12	17.79	17.85	17.84
		25	25	17.94	17.86	17.73
		50	0	17.85	17.88	17.97

LTE Band 7						
BW	MCS Index	RB Size	RB Offset	Low	Mid	High
		Channel		20775	21100	21425
		Frequency (MHz)		2502.5	2535	2567.5
5M	QPSK	1	0	20.93	21.06	20.86
		1	12	20.83	20.93	20.80
		1	24	20.77	20.96	20.71
		12	0	19.97	19.96	19.91
		12	6	19.97	19.92	19.73
		12	13	19.93	20.02	19.76
		25	0	19.96	19.92	19.72
	16QAM	1	0	19.98	19.98	19.92
		1	12	19.93	20.02	19.77
		1	24	19.82	19.83	19.70
		12	0	18.91	18.96	18.75
		12	6	18.94	18.94	18.81
		12	13	18.87	18.85	18.77
		25	0	18.89	18.94	18.82
	64QAM	1	0	18.85	19.05	18.86
		1	12	18.83	18.84	18.88
		1	24	18.72	18.80	18.77
		12	0	17.86	18.03	17.69
		12	6	17.86	17.82	17.77
		12	13	17.73	17.84	17.82
		25	0	17.85	17.89	17.87

LTE Band 12						
BW	MCS Index	RB Size	RB Offset	Low	Mid	High
		Channel		23060	23095	23130
		Frequency (MHz)		704	707.5	711
10M	QPSK	1	0	22.62	22.75	22.71
		1	24	22.61	22.74	22.70
		1	49	22.59	22.72	22.68
		25	0	21.69	21.82	21.78
		25	12	21.66	21.79	21.75
		25	25	21.63	21.76	21.72
		50	0	21.64	21.77	21.73
	16QAM	1	0	21.59	21.68	21.63
		1	24	21.58	21.72	21.68
		1	49	21.58	21.65	21.65
		25	0	20.63	20.74	20.73
		25	12	20.63	20.77	20.74
		25	25	20.59	20.75	20.62
		50	0	20.64	20.69	20.68
	64QAM	1	0	20.35	20.60	20.52
		1	24	20.52	20.52	20.60
		1	49	20.34	20.57	20.45
		25	0	19.60	19.62	19.63
		25	12	19.60	19.51	19.60
		25	25	19.39	19.60	19.56
		50	0	19.45	19.59	19.63

LTE Band 12						
BW	MCS Index	RB Size	RB Offset	Low	Mid	High
		Channel		23035	23095	23155
		Frequency (MHz)		701.5	707.5	713.5
5M	QPSK	1	0	22.62	22.73	22.65
		1	12	22.59	22.71	22.69
		1	24	22.51	22.72	22.66
		12	0	21.59	21.78	21.68
		12	6	21.58	21.73	21.69
		12	13	21.54	21.70	21.64
		25	0	21.64	21.76	21.63
	16QAM	1	0	21.51	21.67	21.59
		1	12	21.49	21.57	21.61
		1	24	21.49	21.59	21.49
		12	0	20.65	20.67	20.77
		12	6	20.54	20.76	20.59
		12	13	20.56	20.60	20.54
		25	0	20.60	20.62	20.68
	64QAM	1	0	20.42	20.65	20.57
		1	12	20.45	20.56	20.49
		1	24	20.31	20.54	20.60
		12	0	19.55	19.65	19.59
		12	6	19.51	19.62	19.66
		12	13	19.35	19.52	19.51
		25	0	19.36	19.61	19.50

LTE Band 12						
BW	MCS Index	RB Size	RB Offset	Low	Mid	High
		Channel		23025	23095	23165
		Frequency (MHz)		700.5	707.5	714.5
3M	QPSK	1	0	22.54	22.68	22.55
		1	7	22.42	22.64	22.53
		1	14	22.39	22.62	22.48
		8	0	21.59	21.66	21.58
		8	3	21.46	21.62	21.64
		8	7	21.60	21.62	21.60
		15	0	21.53	21.59	21.62
	16QAM	1	0	21.33	21.56	21.57
		1	7	21.40	21.62	21.54
		1	14	21.49	21.44	21.49
		8	0	20.53	20.65	20.70
		8	3	20.52	20.44	20.66
		8	7	20.49	20.63	20.50
		15	0	20.51	20.52	20.46
	64QAM	1	0	20.49	20.45	20.43
		1	7	20.45	20.57	20.57
		1	14	20.44	20.49	20.40
		8	0	19.49	19.78	19.55
		8	3	19.50	19.52	19.48
		8	7	19.54	19.59	19.64
		15	0	19.49	19.65	19.56

LTE Band 12						
BW	MCS Index	RB Size	RB Offset	Low	Mid	High
		Channel		23017	23095	23173
		Frequency (MHz)		699.7	707.5	715.3
1.4M	QPSK	1	0	22.46	22.70	22.63
		1	2	22.39	22.52	22.46
		1	5	22.39	22.58	22.54
		3	0	22.49	22.71	22.65
		3	1	22.58	22.66	22.53
		3	3	22.50	22.64	22.64
		6	0	21.45	21.72	21.70
	16QAM	1	0	21.56	21.53	21.48
		1	2	21.42	21.53	21.59
		1	5	21.33	21.55	21.56
		3	0	21.48	21.68	21.69
		3	1	21.47	21.74	21.68
		3	3	21.57	21.52	21.52
		6	0	20.52	20.58	20.56
	64QAM	1	0	20.40	20.47	20.48
		1	2	20.46	20.51	20.57
		1	5	20.29	20.51	20.42
		3	0	20.56	20.74	20.64
		3	1	20.53	20.67	20.66
		3	3	20.48	20.48	20.41
		6	0	19.41	19.67	19.52

LTE Band 13						
BW	MCS Index	RB Size	RB Offset	Low	Mid	High
		Channel		-	23230	-
		Frequency (MHz)		-	782	-
10M	QPSK	1	0	-	22.70	-
		1	24	-	22.52	-
		1	49	-	22.58	-
		25	0	-	22.71	-
		25	12	-	22.66	-
		25	25	-	22.64	-
		50	0	-	21.72	-
	16QAM	1	0	-	21.53	-
		1	24	-	21.53	-
		1	49	-	21.55	-
		25	0	-	21.68	-
		25	12	-	21.74	-
		25	25	-	21.52	-
		50	0	-	20.58	-
	64QAM	1	0	-	20.47	-
		1	24	-	20.51	-
		1	49	-	20.51	-
		25	0	-	20.74	-
		25	12	-	20.67	-
		25	25	-	20.48	-
		50	0	-	19.67	-

LTE Band 13						
BW	MCS Index	RB Size	RB Offset	Low	Mid	High
		Channel		23205	23230	23255
		Frequency (MHz)		779.5	782	784.5
5M	QPSK	1	0	22.38	22.50	22.39
		1	24	22.27	22.39	22.28
		1	49	22.25	22.37	22.26
		25	0	21.31	21.43	21.32
		25	12	21.26	21.38	21.27
		25	25	21.24	21.36	21.25
		50	0	21.25	21.37	21.26
	16QAM	1	0	21.31	21.49	21.33
		1	24	21.26	21.30	21.24
		1	49	21.17	21.33	21.24
		25	0	20.25	20.43	20.27
		25	12	20.25	20.33	20.18
		25	25	20.14	20.33	20.17
		50	0	20.24	20.34	20.18
	64QAM	1	0	20.38	20.43	20.30
		1	24	20.25	20.37	20.22
		1	49	20.24	20.31	20.22
		25	0	19.24	19.36	19.25
		25	12	19.20	19.35	19.25
		25	25	19.18	19.27	19.20
		50	0	19.25	19.37	19.20

LTE Band 17						
BW	MCS Index	RB Size	RB Offset	Low	Mid	High
		Channel		23780	23790	23800
		Frequency (MHz)		709	710	711
10M	QPSK	1	0	22.69	22.70	22.65
		1	24	22.60	22.61	22.56
		1	49	22.57	22.58	22.53
		25	0	21.67	21.68	21.63
		25	12	21.66	21.67	21.62
		25	25	21.64	21.65	21.60
		50	0	21.63	21.64	21.59
	16QAM	1	0	21.59	21.65	21.61
		1	24	21.59	21.56	21.46
		1	49	21.54	21.58	21.43
		25	0	20.66	20.58	20.60
		25	12	20.61	20.66	20.56
		25	25	20.54	20.57	20.51
		50	0	20.63	20.55	20.50
	64QAM	1	0	20.59	20.46	20.40
		1	24	20.33	20.56	20.23
		1	49	20.40	20.49	20.40
		25	0	19.58	19.50	19.42
		25	12	19.53	19.46	19.39
		25	25	19.39	19.38	19.37
		50	0	19.45	19.54	19.38

LTE Band 17						
BW	MCS Index	RB Size	RB Offset	Low	Mid	High
		Channel		23755	23790	23825
		Frequency (MHz)		706.5	710	713.5
5M	QPSK	1	0	22.69	22.65	22.59
		1	12	22.55	22.57	22.48
		1	24	22.52	22.56	22.52
		12	0	21.67	21.68	21.54
		12	6	21.58	21.64	21.57
		12	13	21.58	21.55	21.57
		25	0	21.63	21.59	21.51
	16QAM	1	0	21.58	21.59	21.52
		1	12	21.53	21.50	21.41
		1	24	21.49	21.46	21.46
		12	0	20.52	20.60	20.49
		12	6	20.57	20.58	20.50
		12	13	20.50	20.57	20.51
		25	0	20.62	20.57	20.44
	64QAM	1	0	20.48	20.44	20.64
		1	12	20.46	20.41	20.42
		1	24	20.44	20.43	20.22
		12	0	19.59	19.55	19.54
		12	6	19.44	19.61	19.46
		12	13	19.40	19.35	19.37
		25	0	19.53	19.44	19.44

LTE Band 38						
BW	MCS Index	RB Size	RB Offset	Low	Mid	High
		Channel		37850	38000	38150
		Frequency (MHz)		2580	2595	2610
20M	QPSK	1	0	22.35	22.50	22.42
		1	50	22.20	22.35	22.27
		1	99	22.11	22.26	22.18
		50	0	21.21	21.36	21.28
		50	25	21.18	21.33	21.25
		50	50	21.14	21.29	21.21
		100	0	21.00	21.15	21.07
	16QAM	1	0	21.26	21.41	21.37
		1	50	21.10	21.27	21.26
		1	99	21.10	21.21	21.16
		50	0	20.21	20.33	20.21
		50	25	20.15	20.31	20.25
		50	50	20.08	20.29	20.21
		100	0	19.95	20.14	20.07
	64QAM	1	0	20.33	20.42	20.33
		1	50	20.10	20.35	20.22
		1	99	20.08	20.19	20.14
		50	0	19.15	19.35	19.23
		50	25	19.16	19.32	19.20
		50	50	19.12	19.23	19.20
		100	0	18.90	19.11	19.07

LTE Band 38						
BW	MCS Index	RB Size	RB Offset	Low	Mid	High
		Channel		37825	38000	38175
		Frequency (MHz)		2577.5	2595	2612.5
15M	QPSK	1	0	22.27	22.48	22.39
		1	37	22.13	22.25	22.23
		1	74	22.08	22.17	22.08
		36	0	21.15	21.30	21.19
		36	19	21.15	21.27	21.20
		36	39	21.13	21.23	21.20
		75	0	20.96	21.14	20.98
	16QAM	1	0	21.23	21.45	21.26
		1	37	21.05	21.31	21.19
		1	74	21.06	21.19	21.06
		36	0	20.12	20.26	20.22
		36	19	20.01	20.29	20.12
		36	39	20.07	20.10	20.08
		75	0	19.87	19.97	19.94
	64QAM	1	0	20.27	20.36	20.28
		1	37	20.16	20.21	20.13
		1	74	20.10	20.16	20.11
		36	0	19.05	19.34	19.11
		36	19	19.12	19.18	19.13
		36	39	19.00	19.11	19.04
		75	0	18.92	19.09	18.99

LTE Band 38						
BW	MCS Index	RB Size	RB Offset	Low	Mid	High
		Channel		37800	38000	38200
		Frequency (MHz)		2575	2595	2615
10M	QPSK	1	0	22.26	22.35	22.27
		1	24	21.98	22.14	22.15
		1	49	21.97	22.17	22.08
		25	0	21.09	21.16	21.08
		25	12	21.10	21.11	21.10
		25	25	21.00	21.18	21.09
		50	0	20.80	21.07	20.90
	16QAM	1	0	21.01	21.30	21.21
		1	24	20.97	21.09	21.07
		1	49	20.95	20.95	21.01
		25	0	20.01	20.08	20.11
		25	12	20.07	20.12	20.06
		25	25	19.91	20.15	20.13
		50	0	19.89	20.01	19.89
	64QAM	1	0	20.17	20.36	20.34
		1	24	20.12	20.12	20.26
		1	49	20.07	20.17	20.10
		25	0	19.04	19.10	18.99
		25	12	18.94	19.14	19.01
		25	25	18.97	19.11	19.00
		50	0	18.72	18.93	18.84

LTE Band 38						
BW	MCS Index	RB Size	RB Offset	Low	Mid	High
		Channel		37775	38000	38225
		Frequency (MHz)		2572.5	2595	2617.5
5M	QPSK	1	0	22.25	22.49	22.22
		1	12	22.05	22.16	21.95
		1	24	21.90	22.13	21.98
		12	0	21.06	21.28	21.19
		12	6	21.02	21.22	21.00
		12	13	21.06	21.22	20.93
		25	0	20.81	20.99	20.78
	16QAM	1	0	21.13	21.22	21.31
		1	12	20.92	21.31	21.13
		1	24	21.06	21.04	21.04
		12	0	20.11	20.15	20.07
		12	6	20.04	20.05	19.96
		12	13	20.02	20.03	20.06
		25	0	19.91	20.04	19.87
	64QAM	1	0	20.31	20.27	20.23
		1	12	19.94	20.10	20.12
		1	24	19.91	20.04	20.02
		12	0	18.91	19.15	19.20
		12	6	19.03	19.08	19.18
		12	13	18.97	19.01	19.00
		25	0	18.81	19.00	18.84

LTE Band 41						
BW	MCS Index	RB Size	RB Offset	Low	Mid	High
		Channel		40140	40640	41140
		Frequency (MHz)		2545.0	2595.0	2645.0
20M	QPSK	1	0	22.30	22.53	22.73
		1	50	22.21	22.44	22.64
		1	99	22.13	22.36	22.56
		50	0	21.36	21.59	21.79
		50	25	21.32	21.55	21.75
		50	50	21.26	21.49	21.69
		100	0	21.31	21.54	21.74
	16QAM	1	0	21.28	21.46	21.73
		1	50	21.15	21.37	21.56
		1	99	21.07	21.32	21.49
		50	0	20.34	20.52	20.72
		50	25	20.28	20.48	20.70
		50	50	20.17	20.39	20.67
		100	0	20.26	20.47	20.71
	64QAM	1	0	20.23	20.45	20.63
		1	50	20.21	20.39	20.57
		1	99	20.08	20.28	20.50
		50	0	19.30	19.49	19.70
		50	25	19.31	19.45	19.74
		50	50	19.25	19.43	19.69
		100	0	19.24	19.54	19.69

LTE Band 41						
BW	MCS Index	RB Size	RB Offset	Low	Mid	High
		Channel		40115	40640	41165
		Frequency (MHz)		2542.5	2595.0	2647.5
15M	QPSK	1	0	22.23	22.48	22.70
		1	37	22.21	22.37	22.61
		1	74	22.05	22.33	22.51
		36	0	21.28	21.49	21.70
		36	19	21.30	21.46	21.66
		36	39	21.16	21.46	21.61
		75	0	21.25	21.50	21.68
	16QAM	1	0	21.22	21.41	21.62
		1	37	21.05	21.28	21.54
		1	74	21.07	21.21	21.40
		36	0	20.28	20.55	20.72
		36	19	20.19	20.43	20.60
		36	39	20.12	20.31	20.59
		75	0	20.16	20.42	20.69
	64QAM	1	0	20.27	20.50	20.64
		1	37	20.07	20.33	20.58
		1	74	20.07	20.26	20.41
		36	0	19.34	19.46	19.66
		36	19	19.13	19.47	19.65
		36	39	19.10	19.46	19.56
		75	0	19.21	19.50	19.70

LTE Band 41						
BW	MCS Index	RB Size	RB Offset	Low	Mid	High
		Channel		40090	40640	41190
		Frequency (MHz)		2540.0	2595.0	2650.0
10M	QPSK	1	0	22.15	22.38	22.56
		1	24	22.11	22.23	22.55
		1	49	22.06	22.24	22.45
		25	0	21.16	21.46	21.70
		25	12	21.20	21.50	21.65
		25	25	21.09	21.32	21.57
		50	0	21.19	21.35	21.64
	16QAM	1	0	21.01	21.41	21.50
		1	24	21.02	21.21	21.46
		1	49	20.94	21.17	21.48
		25	0	20.18	20.53	20.69
		25	12	20.12	20.34	20.63
		25	25	20.01	20.35	20.50
		50	0	20.05	20.39	20.53
	64QAM	1	0	20.08	20.39	20.60
		1	24	20.01	20.26	20.53
		1	49	19.95	20.20	20.28
		25	0	19.19	19.45	19.54
		25	12	19.14	19.35	19.70
		25	25	19.15	19.27	19.65
		50	0	19.14	19.29	19.57

LTE Band 41						
BW	MCS Index	RB Size	RB Offset	Low	Mid	High
		Channel		40065	40640	41215
		Frequency (MHz)		2537.5	2595.0	2652.5
5M	QPSK	1	0	22.16	22.43	22.46
		1	12	21.99	22.23	22.38
		1	24	21.98	22.20	22.37
		12	0	21.22	21.45	21.60
		12	6	21.27	21.55	21.57
		12	13	21.06	21.30	21.52
		25	0	21.20	21.40	21.51
	16QAM	1	0	21.12	21.30	21.56
		1	12	21.01	21.28	21.32
		1	24	20.84	21.19	21.41
		12	0	20.31	20.50	20.59
		12	6	20.07	20.46	20.56
		12	13	20.16	20.34	20.44
		25	0	20.15	20.36	20.62
	64QAM	1	0	20.18	20.23	20.57
		1	12	19.94	20.16	20.55
		1	24	19.98	20.21	20.30
		12	0	19.15	19.49	19.50
		12	6	19.16	19.34	19.54
		12	13	19.05	19.35	19.45
		25	0	19.16	19.29	19.67

LTE Band 66						
BW	MCS Index	RB Size	RB Offset	Low	Mid	High
		Channel		132072	132322	132572
		Frequency (MHz)		1720	1745	1770
20M	QPSK	1	0	22.98	22.99	22.97
		1	50	22.78	22.82	22.77
		1	99	22.72	22.76	22.71
		50	0	21.88	21.92	21.87
		50	25	21.80	21.84	21.79
		50	50	21.75	21.79	21.74
		100	0	21.78	21.82	21.77
	16QAM	1	0	21.94	21.98	21.94
		1	50	21.78	21.82	21.72
		1	99	21.69	21.67	21.68
		50	0	20.83	20.92	20.81
		50	25	20.78	20.80	20.74
		50	50	20.75	20.78	20.70
		100	0	20.74	20.81	20.68
	64QAM	1	0	20.89	20.90	20.97
		1	50	20.78	20.75	20.75
		1	99	20.71	20.70	20.71
		50	0	19.87	19.88	19.78
		50	25	19.77	19.76	19.71
		50	50	19.73	19.75	19.64
		100	0	19.72	19.77	19.75

LTE Band 66						
BW	MCS Index	RB Size	RB Offset	Low	Mid	High
		Channel		132047	132322	132597
		Frequency (MHz)		1717.5	1745	1772.5
15M	QPSK	1	0	22.88	22.91	22.89
		1	37	22.74	22.75	22.69
		1	74	22.70	22.71	22.71
		36	0	21.85	21.87	21.85
		36	19	21.80	21.78	21.70
		36	39	21.66	21.75	21.73
		75	0	21.71	21.73	21.69
	16QAM	1	0	21.97	21.91	21.84
		1	37	21.78	21.67	21.68
		1	74	21.58	21.68	21.61
		36	0	20.83	20.80	20.68
		36	19	20.73	20.74	20.67
		36	39	20.62	20.71	20.68
		75	0	20.68	20.72	20.73
	64QAM	1	0	20.90	20.88	20.89
		1	37	20.71	20.71	20.63
		1	74	20.70	20.66	20.62
		36	0	19.78	19.86	19.80
		36	19	19.63	19.77	19.67
		36	39	19.56	19.70	19.61
		75	0	19.67	19.72	19.63

LTE Band 66						
BW	MCS Index	RB Size	RB Offset	Low	Mid	High
		Channel		132022	132322	132622
		Frequency (MHz)		1715	1745	1775
10M	QPSK	1	0	22.87	22.92	22.95
		1	24	22.72	22.65	22.70
		1	49	22.47	22.63	22.61
		25	0	21.77	21.80	21.72
		25	12	21.77	21.74	21.68
		25	25	21.57	21.67	21.60
		50	0	21.66	21.65	21.69
	16QAM	1	0	21.86	21.82	21.79
		1	24	21.63	21.59	21.60
		1	49	21.55	21.57	21.51
		25	0	20.83	20.75	20.63
		25	12	20.70	20.73	20.66
		25	25	20.58	20.62	20.39
		50	0	20.59	20.74	20.69
	64QAM	1	0	20.77	20.83	20.91
		1	24	20.71	20.60	20.61
		1	49	20.55	20.56	20.48
		25	0	19.66	19.76	19.72
		25	12	19.71	19.55	19.53
		25	25	19.53	19.64	19.64
		50	0	19.51	19.73	19.59

LTE Band 66						
BW	MCS Index	RB Size	RB Offset	Low	Mid	High
		Channel		131997	132322	132647
		Frequency (MHz)		1712.5	1745	1777.5
5M	QPSK	1	0	22.87	22.86	22.87
		1	12	22.65	22.67	22.63
		1	24	22.57	22.62	22.49
		12	0	21.74	21.85	21.61
		12	6	21.65	21.68	21.57
		12	13	21.55	21.58	21.44
		25	0	21.66	21.76	21.70
	16QAM	1	0	21.74	21.96	21.68
		1	12	21.64	21.60	21.63
		1	24	21.65	21.62	21.56
		12	0	20.75	20.58	20.70
		12	6	20.61	20.62	20.55
		12	13	20.59	20.63	20.45
		25	0	20.72	20.65	20.70
	64QAM	1	0	20.68	20.83	20.76
		1	12	20.55	20.63	20.59
		1	24	20.58	20.61	20.47
		12	0	19.67	19.67	19.69
		12	6	19.61	19.65	19.44
		12	13	19.50	19.62	19.66
		25	0	19.67	19.68	19.56

LTE Band 66						
BW	MCS Index	RB Size	RB Offset	Low	Mid	High
		Channel		131987	132322	132657
		Frequency (MHz)		1711.5	1745	1778.5
3M	QPSK	1	0	22.76	22.95	22.91
		1	7	22.75	22.68	22.66
		1	14	22.64	22.73	22.57
		8	0	21.72	21.78	21.71
		8	3	21.62	21.82	21.64
		8	7	21.70	21.74	21.57
		15	0	21.63	21.64	21.62
	16QAM	1	0	21.74	21.93	21.91
		1	7	21.47	21.69	21.53
		1	14	21.41	21.69	21.45
		8	0	20.77	20.71	20.58
		8	3	20.66	20.72	20.66
		8	7	20.64	20.68	20.46
		15	0	20.54	20.64	20.51
	64QAM	1	0	20.71	20.88	20.87
		1	7	20.59	20.61	20.61
		1	14	20.46	20.70	20.46
		8	0	19.66	19.67	19.71
		8	3	19.59	19.72	19.56
		8	7	19.57	19.54	19.50
		15	0	19.65	19.58	19.49

LTE Band 66						
BW	MCS Index	RB Size	RB Offset	Low	Mid	High
		Channel		131979	132322	132665
		Frequency (MHz)		1710.7	1745	1779.3
1.4M	QPSK	1	0	22.85	22.82	22.82
		1	2	22.74	22.70	22.60
		1	5	22.62	22.66	22.57
		3	0	22.78	22.85	22.73
		3	1	22.63	22.71	22.70
		3	3	22.61	22.65	22.61
		6	0	21.75	21.74	21.65
	16QAM	1	0	21.75	21.79	21.83
		1	2	21.57	21.63	21.53
		1	5	21.69	21.53	21.66
		3	0	21.74	21.81	21.75
		3	1	21.60	21.60	21.73
		3	3	21.66	21.67	21.58
		6	0	20.70	20.60	20.68
	64QAM	1	0	20.85	20.69	20.67
		1	2	20.53	20.70	20.54
		1	5	20.47	20.54	20.47
		3	0	20.76	20.61	20.74
		3	1	20.69	20.62	20.51
		3	3	20.52	20.70	20.52
		6	0	19.57	19.58	19.59

EIRP Power (dBm)

WCDMA Band 4 Mode

MODE		TX channel 1312					
Antenna Polarity & Test Distance: Horizontal at 3 M							
No.	Freq. (MHz)	Reading (dBm)	S.G Power Value (dBm)	Correction Factor (dB)	EIRP (dBm)	Limit (dBm)	Margin (dB)
1	1712.40	-12.6	25.4	0.7	26.1	30.0	-3.9
Antenna Polarity & Test Distance: Vertical at 3 M							
No.	Freq. (MHz)	Reading (dBm)	S.G Power Value (dBm)	Correction Factor (dB)	EIRP (dBm)	Limit (dBm)	Margin (dB)
1	1712.40	-22.0	15.8	0.7	16.5	30.0	-13.5

MODE		TX channel 1413					
Antenna Polarity & Test Distance: Horizontal at 3 M							
No.	Freq. (MHz)	Reading (dBm)	S.G Power Value (dBm)	Correction Factor (dB)	EIRP (dBm)	Limit (dBm)	Margin (dB)
1	1732.60	-13.8	24.6	0.6	25.2	30.0	-4.8
Antenna Polarity & Test Distance: Vertical at 3 M							
No.	Freq. (MHz)	Reading (dBm)	S.G Power Value (dBm)	Correction Factor (dB)	EIRP (dBm)	Limit (dBm)	Margin (dB)
1	1732.60	-21.2	17.2	0.6	17.8	30.0	-12.2

MODE		TX channel 1513					
Antenna Polarity & Test Distance: Horizontal at 3 M							
No.	Freq. (MHz)	Reading (dBm)	S.G Power Value (dBm)	Correction Factor (dB)	EIRP (dBm)	Limit (dBm)	Margin (dB)
1	1752.60	-12.7	26.1	0.5	26.6	30.0	-3.4
Antenna Polarity & Test Distance: Vertical at 3 M							
No.	Freq. (MHz)	Reading (dBm)	S.G Power Value (dBm)	Correction Factor (dB)	EIRP (dBm)	Limit (dBm)	Margin (dB)
1	1752.60	-20.0	18.8	0.5	19.3	30.0	-10.7

Note: EIRP (dBm) = S.G Power Value (dBm) + Correction Factor (dB).

Modulation Type: QPSK

LTE Band 4

Channel Bandwidth: 1.4MHz

MODE		TX channel 19957					
Antenna Polarity & Test Distance: Horizontal at 3 M							
No.	Freq. (MHz)	Reading (dBm)	S.G Power Value (dBm)	Correction Factor (dB)	EIRP (dBm)	Limit (dBm)	Margin (dB)
1	1710.70	-15.6	22.4	0.7	23.1	30.0	-6.9
Antenna Polarity & Test Distance: Vertical at 3 M							
No.	Freq. (MHz)	Reading (dBm)	S.G Power Value (dBm)	Correction Factor (dB)	EIRP (dBm)	Limit (dBm)	Margin (dB)
1	1710.70	-20.5	17.3	0.7	18.0	30.0	-12.0

MODE		TX channel 20175					
Antenna Polarity & Test Distance: Horizontal at 3 M							
No.	Freq. (MHz)	Reading (dBm)	S.G Power Value (dBm)	Correction Factor (dB)	EIRP (dBm)	Limit (dBm)	Margin (dB)
1	1732.50	-15.5	22.9	0.6	23.5	30.0	-6.5
Antenna Polarity & Test Distance: Vertical at 3 M							
No.	Freq. (MHz)	Reading (dBm)	S.G Power Value (dBm)	Correction Factor (dB)	EIRP (dBm)	Limit (dBm)	Margin (dB)
1	1732.50	-20.4	17.9	0.6	18.5	30.0	-11.5

MODE		TX channel 20393					
Antenna Polarity & Test Distance: Horizontal at 3 M							
No.	Freq. (MHz)	Reading (dBm)	S.G Power Value (dBm)	Correction Factor (dB)	EIRP (dBm)	Limit (dBm)	Margin (dB)
1	1754.30	-15.4	23.4	0.5	23.9	30.0	-6.1
Antenna Polarity & Test Distance: Vertical at 3 M							
No.	Freq. (MHz)	Reading (dBm)	S.G Power Value (dBm)	Correction Factor (dB)	EIRP (dBm)	Limit (dBm)	Margin (dB)
1	1754.30	-20.2	18.7	0.5	19.2	30.0	-10.8

Note: EIRP (dBm) = S.G Power Value (dBm) + Correction Factor (dB).

Channel Bandwidth: 3MHz

MODE		TX channel 19965					
Antenna Polarity & Test Distance: Horizontal at 3 M							
No.	Freq. (MHz)	Reading (dBm)	S.G Power Value (dBm)	Correction Factor (dB)	EIRP (dBm)	Limit (dBm)	Margin (dB)
1	1711.50	-15.4	22.6	0.7	23.3	30.0	-6.7
Antenna Polarity & Test Distance: Vertical at 3 M							
No.	Freq. (MHz)	Reading (dBm)	S.G Power Value (dBm)	Correction Factor (dB)	EIRP (dBm)	Limit (dBm)	Margin (dB)
1	1711.50	-20.2	17.6	0.7	18.3	30.0	-11.7

MODE		TX channel 20175					
Antenna Polarity & Test Distance: Horizontal at 3 M							
No.	Freq. (MHz)	Reading (dBm)	S.G Power Value (dBm)	Correction Factor (dB)	EIRP (dBm)	Limit (dBm)	Margin (dB)
1	1732.50	-15.3	23.1	0.6	23.7	30.0	-6.3
Antenna Polarity & Test Distance: Vertical at 3 M							
No.	Freq. (MHz)	Reading (dBm)	S.G Power Value (dBm)	Correction Factor (dB)	EIRP (dBm)	Limit (dBm)	Margin (dB)
1	1732.50	-20.2	18.1	0.6	18.7	30.0	-11.3

MODE		TX channel 20385					
Antenna Polarity & Test Distance: Horizontal at 3 M							
No.	Freq. (MHz)	Reading (dBm)	S.G Power Value (dBm)	Correction Factor (dB)	EIRP (dBm)	Limit (dBm)	Margin (dB)
1	1753.50	-15.1	23.7	0.5	24.2	30.0	-5.8
Antenna Polarity & Test Distance: Vertical at 3 M							
No.	Freq. (MHz)	Reading (dBm)	S.G Power Value (dBm)	Correction Factor (dB)	EIRP (dBm)	Limit (dBm)	Margin (dB)
1	1753.50	-20.0	18.9	0.5	19.4	30.0	-10.6

Note: EIRP (dBm) = S.G Power Value (dBm) + Correction Factor (dB).

Channel Bandwidth: 5MHz

MODE		TX channel 19975					
Antenna Polarity & Test Distance: Horizontal at 3 M							
No.	Freq. (MHz)	Reading (dBm)	S.G Power Value (dBm)	Correction Factor (dB)	EIRP (dBm)	Limit (dBm)	Margin (dB)
1	1712.50	-15.4	22.7	0.7	23.4	30.0	-6.6
Antenna Polarity & Test Distance: Vertical at 3 M							
No.	Freq. (MHz)	Reading (dBm)	S.G Power Value (dBm)	Correction Factor (dB)	EIRP (dBm)	Limit (dBm)	Margin (dB)
1	1712.50	-20.3	17.6	0.7	18.3	30.0	-11.7

MODE		TX channel 20175					
Antenna Polarity & Test Distance: Horizontal at 3 M							
No.	Freq. (MHz)	Reading (dBm)	S.G Power Value (dBm)	Correction Factor (dB)	EIRP (dBm)	Limit (dBm)	Margin (dB)
1	1732.50	-15.3	23.1	0.6	23.7	30.0	-6.3
Antenna Polarity & Test Distance: Vertical at 3 M							
No.	Freq. (MHz)	Reading (dBm)	S.G Power Value (dBm)	Correction Factor (dB)	EIRP (dBm)	Limit (dBm)	Margin (dB)
1	1732.50	-20.2	18.1	0.6	18.7	30.0	-11.3

MODE		TX channel 20375					
Antenna Polarity & Test Distance: Horizontal at 3 M							
No.	Freq. (MHz)	Reading (dBm)	S.G Power Value (dBm)	Correction Factor (dB)	EIRP (dBm)	Limit (dBm)	Margin (dB)
1	1752.50	-15.2	23.6	0.5	24.1	30.0	-5.9
Antenna Polarity & Test Distance: Vertical at 3 M							
No.	Freq. (MHz)	Reading (dBm)	S.G Power Value (dBm)	Correction Factor (dB)	EIRP (dBm)	Limit (dBm)	Margin (dB)
1	1752.50	-20.1	18.7	0.5	19.2	30.0	-10.8

Note: $EIRP (dBm) = S.G \text{ Power Value (dBm)} + \text{Correction Factor (dB)}$.

Channel Bandwidth: 10MHz

MODE		TX channel 20000					
Antenna Polarity & Test Distance: Horizontal at 3 M							
No.	Freq. (MHz)	Reading (dBm)	S.G Power Value (dBm)	Correction Factor (dB)	EIRP (dBm)	Limit (dBm)	Margin (dB)
1	1715.00	-15.3	22.8	0.7	23.5	30.0	-6.5
Antenna Polarity & Test Distance: Vertical at 3 M							
No.	Freq. (MHz)	Reading (dBm)	S.G Power Value (dBm)	Correction Factor (dB)	EIRP (dBm)	Limit (dBm)	Margin (dB)
1	1715.00	-20.1	17.8	0.7	18.5	30.0	-11.5

MODE		TX channel 20175					
Antenna Polarity & Test Distance: Horizontal at 3 M							
No.	Freq. (MHz)	Reading (dBm)	S.G Power Value (dBm)	Correction Factor (dB)	EIRP (dBm)	Limit (dBm)	Margin (dB)
1	1732.50	-15.2	23.2	0.6	23.8	30.0	-6.2
Antenna Polarity & Test Distance: Vertical at 3 M							
No.	Freq. (MHz)	Reading (dBm)	S.G Power Value (dBm)	Correction Factor (dB)	EIRP (dBm)	Limit (dBm)	Margin (dB)
1	1732.50	-20.1	18.2	0.6	18.8	30.0	-11.2

MODE		TX channel 20350					
Antenna Polarity & Test Distance: Horizontal at 3 M							
No.	Freq. (MHz)	Reading (dBm)	S.G Power Value (dBm)	Correction Factor (dB)	EIRP (dBm)	Limit (dBm)	Margin (dB)
1	1750.00	-15.1	23.7	0.5	24.2	30.0	-5.8
Antenna Polarity & Test Distance: Vertical at 3 M							
No.	Freq. (MHz)	Reading (dBm)	S.G Power Value (dBm)	Correction Factor (dB)	EIRP (dBm)	Limit (dBm)	Margin (dB)
1	1750.00	-19.9	18.9	0.5	19.4	30.0	-10.6

Note: EIRP (dBm) = S.G Power Value (dBm) + Correction Factor (dB).

Channel Bandwidth: 15MHz

MODE		TX channel 20025					
Antenna Polarity & Test Distance: Horizontal at 3 M							
No.	Freq. (MHz)	Reading (dBm)	S.G Power Value (dBm)	Correction Factor (dB)	EIRP (dBm)	Limit (dBm)	Margin (dB)
1	1717.50	-15.1	23.0	0.7	23.7	30.0	-6.3
Antenna Polarity & Test Distance: Vertical at 3 M							
No.	Freq. (MHz)	Reading (dBm)	S.G Power Value (dBm)	Correction Factor (dB)	EIRP (dBm)	Limit (dBm)	Margin (dB)
1	1717.50	-20.0	18.0	0.7	18.7	30.0	-11.3

MODE		TX channel 20175					
Antenna Polarity & Test Distance: Horizontal at 3 M							
No.	Freq. (MHz)	Reading (dBm)	S.G Power Value (dBm)	Correction Factor (dB)	EIRP (dBm)	Limit (dBm)	Margin (dB)
1	1732.50	-15.0	23.4	0.6	24.0	30.0	-6.0
Antenna Polarity & Test Distance: Vertical at 3 M							
No.	Freq. (MHz)	Reading (dBm)	S.G Power Value (dBm)	Correction Factor (dB)	EIRP (dBm)	Limit (dBm)	Margin (dB)
1	1732.50	-19.9	18.4	0.6	19.0	30.0	-11.0

MODE		TX channel 20325					
Antenna Polarity & Test Distance: Horizontal at 3 M							
No.	Freq. (MHz)	Reading (dBm)	S.G Power Value (dBm)	Correction Factor (dB)	EIRP (dBm)	Limit (dBm)	Margin (dB)
1	1747.50	-14.9	23.8	0.5	24.3	30.0	-5.7
Antenna Polarity & Test Distance: Vertical at 3 M							
No.	Freq. (MHz)	Reading (dBm)	S.G Power Value (dBm)	Correction Factor (dB)	EIRP (dBm)	Limit (dBm)	Margin (dB)
1	1747.50	-19.8	18.9	0.5	19.4	30.0	-10.6

Note: $EIRP (dBm) = S.G \text{ Power Value (dBm)} + \text{Correction Factor (dB)}$.

Channel Bandwidth: 20MHz

MODE		TX channel 20050					
Antenna Polarity & Test Distance: Horizontal at 3 M							
No.	Freq. (MHz)	Reading (dBm)	S.G Power Value (dBm)	Correction Factor (dB)	EIRP (dBm)	Limit (dBm)	Margin (dB)
1	1720.00	-14.9	23.3	0.7	24.0	30.0	-6.0
Antenna Polarity & Test Distance: Vertical at 3 M							
No.	Freq. (MHz)	Reading (dBm)	S.G Power Value (dBm)	Correction Factor (dB)	EIRP (dBm)	Limit (dBm)	Margin (dB)
1	1720.00	-19.7	18.3	0.7	19.0	30.0	-11.0

MODE		TX channel 20175					
Antenna Polarity & Test Distance: Horizontal at 3 M							
No.	Freq. (MHz)	Reading (dBm)	S.G Power Value (dBm)	Correction Factor (dB)	EIRP (dBm)	Limit (dBm)	Margin (dB)
1	1732.50	-14.7	23.7	0.6	24.3	30.0	-5.7
Antenna Polarity & Test Distance: Vertical at 3 M							
No.	Freq. (MHz)	Reading (dBm)	S.G Power Value (dBm)	Correction Factor (dB)	EIRP (dBm)	Limit (dBm)	Margin (dB)
1	1732.50	-19.6	18.7	0.6	19.3	30.0	-10.7

MODE		TX channel 20300					
Antenna Polarity & Test Distance: Horizontal at 3 M							
No.	Freq. (MHz)	Reading (dBm)	S.G Power Value (dBm)	Correction Factor (dB)	EIRP (dBm)	Limit (dBm)	Margin (dB)
1	1745.00	-14.5	24.2	0.5	24.7	30.0	-5.3
Antenna Polarity & Test Distance: Vertical at 3 M							
No.	Freq. (MHz)	Reading (dBm)	S.G Power Value (dBm)	Correction Factor (dB)	EIRP (dBm)	Limit (dBm)	Margin (dB)
1	1745.00	-19.5	19.2	0.5	19.7	30.0	-10.3

Note: EIRP (dBm) = S.G Power Value (dBm) + Correction Factor (dB).

LTE Band 7

Channel Bandwidth: 5MHz

MODE		TX channel 20775					
Antenna Polarity & Test Distance: Horizontal at 3 M							
No.	Freq. (MHz)	Reading (dBm)	S.G Power Value (dBm)	Correction Factor (dB)	EIRP (dBm)	Limit (dBm)	Margin (dB)
1	2502.50	-20.7	20.8	0.2	21.0	33.0	-12.0
Antenna Polarity & Test Distance: Vertical at 3 M							
No.	Freq. (MHz)	Reading (dBm)	S.G Power Value (dBm)	Correction Factor (dB)	EIRP (dBm)	Limit (dBm)	Margin (dB)
1	2502.50	-30.3	13.2	0.2	13.4	33.0	-19.6

MODE		TX channel 21100					
Antenna Polarity & Test Distance: Horizontal at 3 M							
No.	Freq. (MHz)	Reading (dBm)	S.G Power Value (dBm)	Correction Factor (dB)	EIRP (dBm)	Limit (dBm)	Margin (dB)
1	2535.00	-21.1	20.6	0.2	20.8	33.0	-12.2
Antenna Polarity & Test Distance: Vertical at 3 M							
No.	Freq. (MHz)	Reading (dBm)	S.G Power Value (dBm)	Correction Factor (dB)	EIRP (dBm)	Limit (dBm)	Margin (dB)
1	2535.00	-30.1	13.5	0.2	13.7	33.0	-19.3

MODE		TX channel 21425					
Antenna Polarity & Test Distance: Horizontal at 3 M							
No.	Freq. (MHz)	Reading (dBm)	S.G Power Value (dBm)	Correction Factor (dB)	EIRP (dBm)	Limit (dBm)	Margin (dB)
1	2567.50	-20.4	21.6	0.2	21.8	33.0	-11.2
Antenna Polarity & Test Distance: Vertical at 3 M							
No.	Freq. (MHz)	Reading (dBm)	S.G Power Value (dBm)	Correction Factor (dB)	EIRP (dBm)	Limit (dBm)	Margin (dB)
1	2567.50	-29.6	14.1	0.2	14.3	33.0	-18.7

Note: EIRP (dBm) = S.G Power Value (dBm) + Correction Factor (dB).

Channel Bandwidth: 10MHz

MODE		TX channel 20800					
Antenna Polarity & Test Distance: Horizontal at 3 M							
No.	Freq. (MHz)	Reading (dBm)	S.G Power Value (dBm)	Correction Factor (dB)	EIRP (dBm)	Limit (dBm)	Margin (dB)
1	2505.00	-20.3	21.2	0.2	21.4	33.0	-11.6
Antenna Polarity & Test Distance: Vertical at 3 M							
No.	Freq. (MHz)	Reading (dBm)	S.G Power Value (dBm)	Correction Factor (dB)	EIRP (dBm)	Limit (dBm)	Margin (dB)
1	2505.00	-29.3	14.2	0.2	14.4	33.0	-18.6

MODE		TX channel 21100					
Antenna Polarity & Test Distance: Horizontal at 3 M							
No.	Freq. (MHz)	Reading (dBm)	S.G Power Value (dBm)	Correction Factor (dB)	EIRP (dBm)	Limit (dBm)	Margin (dB)
1	2535.00	-20.5	21.2	0.2	21.4	33.0	-11.6
Antenna Polarity & Test Distance: Vertical at 3 M							
No.	Freq. (MHz)	Reading (dBm)	S.G Power Value (dBm)	Correction Factor (dB)	EIRP (dBm)	Limit (dBm)	Margin (dB)
1	2535.00	-29.4	14.2	0.2	14.4	33.0	-18.6

MODE		TX channel 21400					
Antenna Polarity & Test Distance: Horizontal at 3 M							
No.	Freq. (MHz)	Reading (dBm)	S.G Power Value (dBm)	Correction Factor (dB)	EIRP (dBm)	Limit (dBm)	Margin (dB)
1	2565.00	-20.1	21.9	0.2	22.1	33.0	-10.9
Antenna Polarity & Test Distance: Vertical at 3 M							
No.	Freq. (MHz)	Reading (dBm)	S.G Power Value (dBm)	Correction Factor (dB)	EIRP (dBm)	Limit (dBm)	Margin (dB)
1	2565.00	-29.0	14.7	0.2	14.9	33.0	-18.1

Note: EIRP (dBm) = S.G Power Value (dBm) + Correction Factor (dB).

Channel Bandwidth: 15MHz

MODE		TX channel 20825					
Antenna Polarity & Test Distance: Horizontal at 3 M							
No.	Freq. (MHz)	Reading (dBm)	S.G Power Value (dBm)	Correction Factor (dB)	EIRP (dBm)	Limit (dBm)	Margin (dB)
1	2507.50	-20.0	21.5	0.2	21.7	33.0	-11.3
Antenna Polarity & Test Distance: Vertical at 3 M							
No.	Freq. (MHz)	Reading (dBm)	S.G Power Value (dBm)	Correction Factor (dB)	EIRP (dBm)	Limit (dBm)	Margin (dB)
1	2507.50	-29.1	14.4	0.2	14.6	33.0	-18.4

MODE		TX channel 21100					
Antenna Polarity & Test Distance: Horizontal at 3 M							
No.	Freq. (MHz)	Reading (dBm)	S.G Power Value (dBm)	Correction Factor (dB)	EIRP (dBm)	Limit (dBm)	Margin (dB)
1	2535.00	-20.3	21.4	0.2	21.6	33.0	-11.4
Antenna Polarity & Test Distance: Vertical at 3 M							
No.	Freq. (MHz)	Reading (dBm)	S.G Power Value (dBm)	Correction Factor (dB)	EIRP (dBm)	Limit (dBm)	Margin (dB)
1	2535.00	-29.2	14.4	0.2	14.6	33.0	-18.4

MODE		TX channel 21375					
Antenna Polarity & Test Distance: Horizontal at 3 M							
No.	Freq. (MHz)	Reading (dBm)	S.G Power Value (dBm)	Correction Factor (dB)	EIRP (dBm)	Limit (dBm)	Margin (dB)
1	2562.50	-19.8	22.2	0.2	22.4	33.0	-10.6
Antenna Polarity & Test Distance: Vertical at 3 M							
No.	Freq. (MHz)	Reading (dBm)	S.G Power Value (dBm)	Correction Factor (dB)	EIRP (dBm)	Limit (dBm)	Margin (dB)
1	2562.50	-28.8	14.9	0.2	15.1	33.0	-17.9

Note: EIRP (dBm) = S.G Power Value (dBm) + Correction Factor (dB).

Channel Bandwidth: 20MHz

MODE		TX channel 20850					
Antenna Polarity & Test Distance: Horizontal at 3 M							
No.	Freq. (MHz)	Reading (dBm)	S.G Power Value (dBm)	Correction Factor (dB)	EIRP (dBm)	Limit (dBm)	Margin (dB)
1	2510.00	-19.7	21.8	0.2	22.0	33.0	-11.0
Antenna Polarity & Test Distance: Vertical at 3 M							
No.	Freq. (MHz)	Reading (dBm)	S.G Power Value (dBm)	Correction Factor (dB)	EIRP (dBm)	Limit (dBm)	Margin (dB)
1	2510.00	-28.7	14.8	0.2	15.0	33.0	-18.0

MODE		TX channel 21100					
Antenna Polarity & Test Distance: Horizontal at 3 M							
No.	Freq. (MHz)	Reading (dBm)	S.G Power Value (dBm)	Correction Factor (dB)	EIRP (dBm)	Limit (dBm)	Margin (dB)
1	2535.00	-20.1	21.6	0.2	21.8	33.0	-11.2
Antenna Polarity & Test Distance: Vertical at 3 M							
No.	Freq. (MHz)	Reading (dBm)	S.G Power Value (dBm)	Correction Factor (dB)	EIRP (dBm)	Limit (dBm)	Margin (dB)
1	2535.00	-29.0	14.6	0.2	14.8	33.0	-18.2

MODE		TX channel 21350					
Antenna Polarity & Test Distance: Horizontal at 3 M							
No.	Freq. (MHz)	Reading (dBm)	S.G Power Value (dBm)	Correction Factor (dB)	EIRP (dBm)	Limit (dBm)	Margin (dB)
1	2560.00	-19.5	22.4	0.2	22.6	33.0	-10.4
Antenna Polarity & Test Distance: Vertical at 3 M							
No.	Freq. (MHz)	Reading (dBm)	S.G Power Value (dBm)	Correction Factor (dB)	EIRP (dBm)	Limit (dBm)	Margin (dB)
1	2560.00	-28.3	15.4	0.2	15.6	33.0	-17.4

Note: EIRP (dBm) = S.G Power Value (dBm) + Correction Factor (dB).

CA Mode

Channel Bandwidth: 20MHz+20MHz

MODE		TX channel 20850+21048					
Antenna Polarity & Test Distance: Horizontal at 3 M							
No.	Freq. (MHz)	Reading (dBm)	S.G Power Value (dBm)	Correction Factor (dB)	EIRP (dBm)	Limit (dBm)	Margin (dB)
1	2519.9	-21.0	20.7	0.1	20.8	33.0	-12.2
Antenna Polarity & Test Distance: Vertical at 3 M							
No.	Freq. (MHz)	Reading (dBm)	S.G Power Value (dBm)	Correction Factor (dB)	EIRP (dBm)	Limit (dBm)	Margin (dB)
1	2519.9	-21.0	22.7	0.1	22.8	33.0	-10.2

MODE		TX channel 21100+21298					
Antenna Polarity & Test Distance: Horizontal at 3 M							
No.	Freq. (MHz)	Reading (dBm)	S.G Power Value (dBm)	Correction Factor (dB)	EIRP (dBm)	Limit (dBm)	Margin (dB)
1	2544.9	-21.9	19.9	0.2	20.1	33.0	-12.9
Antenna Polarity & Test Distance: Vertical at 3 M							
No.	Freq. (MHz)	Reading (dBm)	S.G Power Value (dBm)	Correction Factor (dB)	EIRP (dBm)	Limit (dBm)	Margin (dB)
1	2544.9	-21.0	22.6	0.2	22.8	33.0	-10.2

MODE		TX channel 21350+21152					
Antenna Polarity & Test Distance: Horizontal at 3 M							
No.	Freq. (MHz)	Reading (dBm)	S.G Power Value (dBm)	Correction Factor (dB)	EIRP (dBm)	Limit (dBm)	Margin (dB)
1	2550.1	-22.6	19.3	0.2	19.5	33.0	-13.5
Antenna Polarity & Test Distance: Vertical at 3 M							
No.	Freq. (MHz)	Reading (dBm)	S.G Power Value (dBm)	Correction Factor (dB)	EIRP (dBm)	Limit (dBm)	Margin (dB)
1	2550.1	-21.7	22.0	0.2	22.2	33.0	-10.8

Note: EIRP (dBm) = S.G Power Value (dBm) + Correction Factor (dB).

LTE Band 12

Channel Bandwidth: 1.4MHz

MODE		TX channel 23017					
Antenna Polarity & Test Distance: Horizontal at 3 M							
No.	Freq. (MHz)	Reading (dBm)	S.G Power Value (dBm)	Correction Factor (dB)	ERP (dBm)	Limit (dBm)	Margin (dB)
1	699.70	-17.7	6.8	3.5	10.3	34.8	-24.5
Antenna Polarity & Test Distance: Vertical at 3 M							
No.	Freq. (MHz)	Reading (dBm)	S.G Power Value (dBm)	Correction Factor (dB)	ERP (dBm)	Limit (dBm)	Margin (dB)
1	699.70	-14.2	13.3	3.5	16.8	34.8	-18.0

MODE		TX channel 23095					
Antenna Polarity & Test Distance: Horizontal at 3 M							
No.	Freq. (MHz)	Reading (dBm)	S.G Power Value (dBm)	Correction Factor (dB)	ERP (dBm)	Limit (dBm)	Margin (dB)
1	707.50	-16.9	7.9	3.5	11.4	34.8	-23.4
Antenna Polarity & Test Distance: Vertical at 3 M							
No.	Freq. (MHz)	Reading (dBm)	S.G Power Value (dBm)	Correction Factor (dB)	ERP (dBm)	Limit (dBm)	Margin (dB)
1	707.50	-11.8	16.0	3.5	19.5	34.8	-15.3

MODE		TX channel 23173					
Antenna Polarity & Test Distance: Horizontal at 3 M							
No.	Freq. (MHz)	Reading (dBm)	S.G Power Value (dBm)	Correction Factor (dB)	ERP (dBm)	Limit (dBm)	Margin (dB)
1	715.30	-17.9	7.1	3.5	10.6	34.8	-24.2
Antenna Polarity & Test Distance: Vertical at 3 M							
No.	Freq. (MHz)	Reading (dBm)	S.G Power Value (dBm)	Correction Factor (dB)	ERP (dBm)	Limit (dBm)	Margin (dB)
1	715.30	-12.0	15.6	3.5	19.1	34.8	-15.7

Note: ERP (dBm) = S.G Power Value (dBm) + Correction Factor (dB).

Channel Bandwidth: 3MHz

MODE		TX channel 23025					
Antenna Polarity & Test Distance: Horizontal at 3 M							
No.	Freq. (MHz)	Reading (dBm)	S.G Power Value (dBm)	Correction Factor (dB)	ERP (dBm)	Limit (dBm)	Margin (dB)
1	700.50	-17.2	7.3	3.5	10.8	34.8	-24.0
Antenna Polarity & Test Distance: Vertical at 3 M							
No.	Freq. (MHz)	Reading (dBm)	S.G Power Value (dBm)	Correction Factor (dB)	ERP (dBm)	Limit (dBm)	Margin (dB)
1	700.50	-11.9	15.7	3.5	19.2	34.8	-15.6

MODE		TX channel 23095					
Antenna Polarity & Test Distance: Horizontal at 3 M							
No.	Freq. (MHz)	Reading (dBm)	S.G Power Value (dBm)	Correction Factor (dB)	ERP (dBm)	Limit (dBm)	Margin (dB)
1	707.50	-17.1	7.6	3.5	11.1	34.8	-23.7
Antenna Polarity & Test Distance: Vertical at 3 M							
No.	Freq. (MHz)	Reading (dBm)	S.G Power Value (dBm)	Correction Factor (dB)	ERP (dBm)	Limit (dBm)	Margin (dB)
1	707.50	-11.9	15.9	3.5	19.4	34.8	-15.4

MODE		TX channel 23165					
Antenna Polarity & Test Distance: Horizontal at 3 M							
No.	Freq. (MHz)	Reading (dBm)	S.G Power Value (dBm)	Correction Factor (dB)	ERP (dBm)	Limit (dBm)	Margin (dB)
1	714.50	-17.6	7.4	3.5	10.9	34.8	-23.9
Antenna Polarity & Test Distance: Vertical at 3 M							
No.	Freq. (MHz)	Reading (dBm)	S.G Power Value (dBm)	Correction Factor (dB)	ERP (dBm)	Limit (dBm)	Margin (dB)
1	714.50	-11.8	15.8	3.5	19.3	34.8	-15.5

Note: ERP (dBm) = S.G Power Value (dBm) + Correction Factor (dB).

Channel Bandwidth: 5MHz

MODE		TX channel 23035					
Antenna Polarity & Test Distance: Horizontal at 3 M							
No.	Freq. (MHz)	Reading (dBm)	S.G Power Value (dBm)	Correction Factor (dB)	ERP (dBm)	Limit (dBm)	Margin (dB)
1	701.50	-17.3	7.3	3.4	10.7	34.8	-24.1
Antenna Polarity & Test Distance: Vertical at 3 M							
No.	Freq. (MHz)	Reading (dBm)	S.G Power Value (dBm)	Correction Factor (dB)	ERP (dBm)	Limit (dBm)	Margin (dB)
1	701.50	-11.8	15.9	3.4	19.3	34.8	-15.5

MODE		TX channel 23095					
Antenna Polarity & Test Distance: Horizontal at 3 M							
No.	Freq. (MHz)	Reading (dBm)	S.G Power Value (dBm)	Correction Factor (dB)	ERP (dBm)	Limit (dBm)	Margin (dB)
1	707.50	-18.1	6.6	3.5	10.1	34.8	-24.7
Antenna Polarity & Test Distance: Vertical at 3 M							
No.	Freq. (MHz)	Reading (dBm)	S.G Power Value (dBm)	Correction Factor (dB)	EIRP (dBm)	Limit (dBm)	Margin (dB)
1	707.50	-12.4	15.4	3.5	18.9	34.8	-15.9

MODE		TX channel 23155					
Antenna Polarity & Test Distance: Horizontal at 3 M							
No.	Freq. (MHz)	Reading (dBm)	S.G Power Value (dBm)	Correction Factor (dB)	ERP (dBm)	Limit (dBm)	Margin (dB)
1	713.50	-17.8	7.2	3.5	10.7	34.8	-24.1
Antenna Polarity & Test Distance: Vertical at 3 M							
No.	Freq. (MHz)	Reading (dBm)	S.G Power Value (dBm)	Correction Factor (dB)	EIRP (dBm)	Limit (dBm)	Margin (dB)
1	713.50	-12.1	15.6	3.5	19.1	34.8	-15.7

Note: ERP (dBm) = S.G Power Value (dBm) + Correction Factor (dB).

Channel Bandwidth: 10MHz

MODE		TX channel 23060					
Antenna Polarity & Test Distance: Horizontal at 3 M							
No.	Freq. (MHz)	Reading (dBm)	S.G Power Value (dBm)	Correction Factor (dB)	ERP (dBm)	Limit (dBm)	Margin (dB)
1	704.00	-17.4	7.3	3.5	10.8	34.8	-24.0
Antenna Polarity & Test Distance: Vertical at 3 M							
No.	Freq. (MHz)	Reading (dBm)	S.G Power Value (dBm)	Correction Factor (dB)	ERP (dBm)	Limit (dBm)	Margin (dB)
1	704.00	-11.8	15.9	3.5	19.4	34.8	-15.4

MODE		TX channel 23095					
Antenna Polarity & Test Distance: Horizontal at 3 M							
No.	Freq. (MHz)	Reading (dBm)	S.G Power Value (dBm)	Correction Factor (dB)	ERP (dBm)	Limit (dBm)	Margin (dB)
1	707.50	-17.4	7.4	3.5	10.9	34.8	-23.9
Antenna Polarity & Test Distance: Vertical at 3 M							
No.	Freq. (MHz)	Reading (dBm)	S.G Power Value (dBm)	Correction Factor (dB)	ERP (dBm)	Limit (dBm)	Margin (dB)
1	707.50	-11.8	16.0	3.5	19.5	34.8	-15.3

MODE		TX channel 23130					
Antenna Polarity & Test Distance: Horizontal at 3 M							
No.	Freq. (MHz)	Reading (dBm)	S.G Power Value (dBm)	Correction Factor (dB)	ERP (dBm)	Limit (dBm)	Margin (dB)
1	711.00	-18.0	7.0	3.5	10.5	34.8	-24.3
Antenna Polarity & Test Distance: Vertical at 3 M							
No.	Freq. (MHz)	Reading (dBm)	S.G Power Value (dBm)	Correction Factor (dB)	ERP (dBm)	Limit (dBm)	Margin (dB)
1	711.00	-12.2	15.4	3.5	18.9	34.8	-15.9

Note: ERP (dBm) = S.G Power Value (dBm) + Correction Factor (dB).

LTE Band 13

Channel Bandwidth: 5MHz

MODE		TX channel 23205					
Antenna Polarity & Test Distance: Horizontal at 3 M							
No.	Freq. (MHz)	Reading (dBm)	S.G Power Value (dBm)	Correction Factor (dB)	ERP (dBm)	Limit (dBm)	Margin (dB)
1	779.50	-18.2	7.8	4.0	11.8	34.8	-23.0
Antenna Polarity & Test Distance: Vertical at 3 M							
No.	Freq. (MHz)	Reading (dBm)	S.G Power Value (dBm)	Correction Factor (dB)	ERP (dBm)	Limit (dBm)	Margin (dB)
1	779.50	-12.9	15.2	4.0	19.2	34.8	-15.6

MODE		TX channel 23230					
Antenna Polarity & Test Distance: Horizontal at 3 M							
No.	Freq. (MHz)	Reading (dBm)	S.G Power Value (dBm)	Correction Factor (dB)	ERP (dBm)	Limit (dBm)	Margin (dB)
1	782.00	-18.4	7.6	4.0	11.6	34.8	-23.2
Antenna Polarity & Test Distance: Vertical at 3 M							
No.	Freq. (MHz)	Reading (dBm)	S.G Power Value (dBm)	Correction Factor (dB)	ERP (dBm)	Limit (dBm)	Margin (dB)
1	782.00	-12.8	15.1	4.0	19.1	34.8	-15.7

MODE		TX channel 23255					
Antenna Polarity & Test Distance: Horizontal at 3 M							
No.	Freq. (MHz)	Reading (dBm)	S.G Power Value (dBm)	Correction Factor (dB)	ERP (dBm)	Limit (dBm)	Margin (dB)
1	784.50	-18.5	7.6	4.0	11.6	34.8	-23.2
Antenna Polarity & Test Distance: Vertical at 3 M							
No.	Freq. (MHz)	Reading (dBm)	S.G Power Value (dBm)	Correction Factor (dB)	ERP (dBm)	Limit (dBm)	Margin (dB)
1	784.50	-13.0	14.9	4.0	18.9	34.8	-15.9

Note: ERP (dBm) = S.G Power Value (dBm) + Correction Factor (dB).

Channel Bandwidth: 10MHz

MODE		TX channel 23230					
Antenna Polarity & Test Distance: Horizontal at 3 M							
No.	Freq. (MHz)	Reading (dBm)	S.G Power Value (dBm)	Correction Factor (dB)	ERP (dBm)	Limit (dBm)	Margin (dB)
1	782.00	-18.1	7.9	4.0	11.9	34.8	-22.9
Antenna Polarity & Test Distance: Vertical at 3 M							
No.	Freq. (MHz)	Reading (dBm)	S.G Power Value (dBm)	Correction Factor (dB)	ERP (dBm)	Limit (dBm)	Margin (dB)
1	782.00	-12.8	15.1	4.0	19.1	34.8	-15.7

Note: ERP (dBm) = S.G Power Value (dBm) + Correction Factor (dB).

LTE Band 17

Channel Bandwidth: 5MHz

MODE		TX channel 23755					
Antenna Polarity & Test Distance: Horizontal at 3 M							
No.	Freq. (MHz)	Reading (dBm)	S.G Power Value (dBm)	Correction Factor (dB)	ERP (dBm)	Limit (dBm)	Margin (dB)
1	706.50	-16.9	7.8	3.5	11.3	34.8	-23.5
Antenna Polarity & Test Distance: Vertical at 3 M							
No.	Freq. (MHz)	Reading (dBm)	S.G Power Value (dBm)	Correction Factor (dB)	ERP (dBm)	Limit (dBm)	Margin (dB)
1	706.50	-12.6	15.0	3.5	18.5	34.8	-16.3

MODE		TX channel 23790					
Antenna Polarity & Test Distance: Horizontal at 3 M							
No.	Freq. (MHz)	Reading (dBm)	S.G Power Value (dBm)	Correction Factor (dB)	ERP (dBm)	Limit (dBm)	Margin (dB)
1	710.00	-17.2	7.6	3.5	11.1	34.8	-23.7
Antenna Polarity & Test Distance: Vertical at 3 M							
No.	Freq. (MHz)	Reading (dBm)	S.G Power Value (dBm)	Correction Factor (dB)	ERP (dBm)	Limit (dBm)	Margin (dB)
1	710.00	-12.7	14.9	3.5	18.4	34.8	-16.4

MODE		TX channel 23825					
Antenna Polarity & Test Distance: Horizontal at 3 M							
No.	Freq. (MHz)	Reading (dBm)	S.G Power Value (dBm)	Correction Factor (dB)	ERP (dBm)	Limit (dBm)	Margin (dB)
1	713.50	-17.3	7.7	3.5	11.2	34.8	-23.6
Antenna Polarity & Test Distance: Vertical at 3 M							
No.	Freq. (MHz)	Reading (dBm)	S.G Power Value (dBm)	Correction Factor (dB)	ERP (dBm)	Limit (dBm)	Margin (dB)
1	713.50	-12.9	14.9	3.5	18.4	34.8	-16.4

Note: ERP (dBm) = S.G Power Value (dBm) + Correction Factor (dB).

Channel Bandwidth: 10MHz

MODE		TX channel 23780					
Antenna Polarity & Test Distance: Horizontal at 3 M							
No.	Freq. (MHz)	Reading (dBm)	S.G Power Value (dBm)	Correction Factor (dB)	ERP (dBm)	Limit (dBm)	Margin (dB)
1	709.00	-16.9	7.8	3.5	11.3	34.8	-23.5
Antenna Polarity & Test Distance: Vertical at 3 M							
No.	Freq. (MHz)	Reading (dBm)	S.G Power Value (dBm)	Correction Factor (dB)	ERP (dBm)	Limit (dBm)	Margin (dB)
1	709.00	-13.0	14.6	3.5	18.1	34.8	-16.7

MODE		TX channel 23790					
Antenna Polarity & Test Distance: Horizontal at 3 M							
No.	Freq. (MHz)	Reading (dBm)	S.G Power Value (dBm)	Correction Factor (dB)	ERP (dBm)	Limit (dBm)	Margin (dB)
1	710.00	-17.2	7.6	3.5	11.1	34.8	-23.7
Antenna Polarity & Test Distance: Vertical at 3 M							
No.	Freq. (MHz)	Reading (dBm)	S.G Power Value (dBm)	Correction Factor (dB)	ERP (dBm)	Limit (dBm)	Margin (dB)
1	710.00	-12.9	14.7	3.5	18.2	34.8	-16.6

MODE		TX channel 23800					
Antenna Polarity & Test Distance: Horizontal at 3 M							
No.	Freq. (MHz)	Reading (dBm)	S.G Power Value (dBm)	Correction Factor (dB)	ERP (dBm)	Limit (dBm)	Margin (dB)
1	711.00	-17.4	7.6	3.5	11.1	34.8	-23.7
Antenna Polarity & Test Distance: Vertical at 3 M							
No.	Freq. (MHz)	Reading (dBm)	S.G Power Value (dBm)	Correction Factor (dB)	ERP (dBm)	Limit (dBm)	Margin (dB)
1	711.00	-12.8	14.8	3.5	18.3	34.8	-16.5

Note: ERP (dBm) = S.G Power Value (dBm) + Correction Factor (dB).

LTE Band 38

Channel Bandwidth: 5MHz

MODE		TX channel 37775					
Antenna Polarity & Test Distance: Horizontal at 3 M							
No.	Freq. (MHz)	Reading (dBm)	S.G Power Value (dBm)	Correction Factor (dB)	EIRP (dBm)	Limit (dBm)	Margin (dB)
1	2575.50	-17.5	24.6	0.2	24.8	33.0	-8.2
Antenna Polarity & Test Distance: Vertical at 3 M							
No.	Freq. (MHz)	Reading (dBm)	S.G Power Value (dBm)	Correction Factor (dB)	EIRP (dBm)	Limit (dBm)	Margin (dB)
1	2575.50	-25.3	18.4	0.2	18.6	33.0	-14.4

MODE		TX channel 38000					
Antenna Polarity & Test Distance: Horizontal at 3 M							
No.	Freq. (MHz)	Reading (dBm)	S.G Power Value (dBm)	Correction Factor (dB)	EIRP (dBm)	Limit (dBm)	Margin (dB)
1	2595.00	-17.3	24.9	0.2	25.1	33.0	-7.9
Antenna Polarity & Test Distance: Vertical at 3 M							
No.	Freq. (MHz)	Reading (dBm)	S.G Power Value (dBm)	Correction Factor (dB)	EIRP (dBm)	Limit (dBm)	Margin (dB)
1	2595.00	-25.3	18.5	0.2	18.7	33.0	-14.3

MODE		TX channel 38225					
Antenna Polarity & Test Distance: Horizontal at 3 M							
No.	Freq. (MHz)	Reading (dBm)	S.G Power Value (dBm)	Correction Factor (dB)	EIRP (dBm)	Limit (dBm)	Margin (dB)
1	2617.50	-18.0	24.4	0.2	24.6	33.0	-8.4
Antenna Polarity & Test Distance: Vertical at 3 M							
No.	Freq. (MHz)	Reading (dBm)	S.G Power Value (dBm)	Correction Factor (dB)	EIRP (dBm)	Limit (dBm)	Margin (dB)
1	2617.50	-25.6	18.2	0.2	18.4	33.0	-14.6

Note: EIRP (dBm) = S.G Power Value (dBm) + Correction Factor (dB).

Channel Bandwidth: 10MHz

MODE		TX channel 37800					
Antenna Polarity & Test Distance: Horizontal at 3 M							
No.	Freq. (MHz)	Reading (dBm)	S.G Power Value (dBm)	Correction Factor (dB)	EIRP (dBm)	Limit (dBm)	Margin (dB)
1	2575.00	-18.1	24.0	0.2	24.2	33.0	-8.8
Antenna Polarity & Test Distance: Vertical at 3 M							
No.	Freq. (MHz)	Reading (dBm)	S.G Power Value (dBm)	Correction Factor (dB)	EIRP (dBm)	Limit (dBm)	Margin (dB)
1	2575.00	-25.3	18.4	0.2	18.6	33.0	-14.4

MODE		TX channel 38000					
Antenna Polarity & Test Distance: Horizontal at 3 M							
No.	Freq. (MHz)	Reading (dBm)	S.G Power Value (dBm)	Correction Factor (dB)	EIRP (dBm)	Limit (dBm)	Margin (dB)
1	2595.00	-18.1	24.1	0.2	24.3	33.0	-8.7
Antenna Polarity & Test Distance: Vertical at 3 M							
No.	Freq. (MHz)	Reading (dBm)	S.G Power Value (dBm)	Correction Factor (dB)	EIRP (dBm)	Limit (dBm)	Margin (dB)
1	2595.00	-25.4	18.4	0.2	18.6	33.0	-14.4

MODE		TX channel 38200					
Antenna Polarity & Test Distance: Horizontal at 3 M							
No.	Freq. (MHz)	Reading (dBm)	S.G Power Value (dBm)	Correction Factor (dB)	EIRP (dBm)	Limit (dBm)	Margin (dB)
1	2615.00	-18.3	24.1	0.2	24.3	33.0	-8.7
Antenna Polarity & Test Distance: Vertical at 3 M							
No.	Freq. (MHz)	Reading (dBm)	S.G Power Value (dBm)	Correction Factor (dB)	EIRP (dBm)	Limit (dBm)	Margin (dB)
1	2615.00	-25.9	17.9	0.2	18.1	33.0	-14.9

Note: EIRP (dBm) = S.G Power Value (dBm) + Correction Factor (dB).

Channel Bandwidth: 15MHz

MODE		TX channel 37825					
Antenna Polarity & Test Distance: Horizontal at 3 M							
No.	Freq. (MHz)	Reading (dBm)	S.G Power Value (dBm)	Correction Factor (dB)	EIRP (dBm)	Limit (dBm)	Margin (dB)
1	2577.50	-17.7	24.4	0.2	24.6	33.0	-8.4
Antenna Polarity & Test Distance: Vertical at 3 M							
No.	Freq. (MHz)	Reading (dBm)	S.G Power Value (dBm)	Correction Factor (dB)	EIRP (dBm)	Limit (dBm)	Margin (dB)
1	2577.50	-25.4	18.3	0.2	18.5	33.0	-14.5

MODE		TX channel 38000					
Antenna Polarity & Test Distance: Horizontal at 3 M							
No.	Freq. (MHz)	Reading (dBm)	S.G Power Value (dBm)	Correction Factor (dB)	EIRP (dBm)	Limit (dBm)	Margin (dB)
1	2595.00	-17.7	24.5	0.2	24.7	33.0	-8.3
Antenna Polarity & Test Distance: Vertical at 3 M							
No.	Freq. (MHz)	Reading (dBm)	S.G Power Value (dBm)	Correction Factor (dB)	EIRP (dBm)	Limit (dBm)	Margin (dB)
1	2595.00	-25.6	18.2	0.2	18.4	33.0	-14.6

MODE		TX channel 38175					
Antenna Polarity & Test Distance: Horizontal at 3 M							
No.	Freq. (MHz)	Reading (dBm)	S.G Power Value (dBm)	Correction Factor (dB)	EIRP (dBm)	Limit (dBm)	Margin (dB)
1	2612.50	-17.7	24.7	0.2	24.9	33.0	-8.1
Antenna Polarity & Test Distance: Vertical at 3 M							
No.	Freq. (MHz)	Reading (dBm)	S.G Power Value (dBm)	Correction Factor (dB)	EIRP (dBm)	Limit (dBm)	Margin (dB)
1	2612.50	-25.2	18.6	0.2	18.8	33.0	-14.2

Note: EIRP (dBm) = S.G Power Value (dBm) + Correction Factor (dB).

Channel Bandwidth: 20MHz

MODE		TX channel 37850					
Antenna Polarity & Test Distance: Horizontal at 3 M							
No.	Freq. (MHz)	Reading (dBm)	S.G Power Value (dBm)	Correction Factor (dB)	EIRP (dBm)	Limit (dBm)	Margin (dB)
1	2580.00	-17.8	24.4	0.1	24.5	33.0	-8.5
Antenna Polarity & Test Distance: Vertical at 3 M							
No.	Freq. (MHz)	Reading (dBm)	S.G Power Value (dBm)	Correction Factor (dB)	EIRP (dBm)	Limit (dBm)	Margin (dB)
1	2580.00	-26.0	17.8	0.1	17.9	33.0	-15.1

MODE		TX channel 38000					
Antenna Polarity & Test Distance: Horizontal at 3 M							
No.	Freq. (MHz)	Reading (dBm)	S.G Power Value (dBm)	Correction Factor (dB)	EIRP (dBm)	Limit (dBm)	Margin (dB)
1	2595.00	-18.2	24.0	0.2	24.2	33.0	-8.8
Antenna Polarity & Test Distance: Vertical at 3 M							
No.	Freq. (MHz)	Reading (dBm)	S.G Power Value (dBm)	Correction Factor (dB)	EIRP (dBm)	Limit (dBm)	Margin (dB)
1	2595.00	-26.3	17.5	0.2	17.7	33.0	-15.3

MODE		TX channel 38150					
Antenna Polarity & Test Distance: Horizontal at 3 M							
No.	Freq. (MHz)	Reading (dBm)	S.G Power Value (dBm)	Correction Factor (dB)	EIRP (dBm)	Limit (dBm)	Margin (dB)
1	2610.00	-17.6	24.8	0.2	25.0	33.0	-8.0
Antenna Polarity & Test Distance: Vertical at 3 M							
No.	Freq. (MHz)	Reading (dBm)	S.G Power Value (dBm)	Correction Factor (dB)	EIRP (dBm)	Limit (dBm)	Margin (dB)
1	2610.00	-26.0	17.8	0.2	18.0	33.0	-15.0

Note: EIRP (dBm) = S.G Power Value (dBm) + Correction Factor (dB).

LTE Band 41

Channel Bandwidth: 5MHz

MODE		TX channel 40065					
Antenna Polarity & Test Distance: Horizontal at 3 M							
No.	Freq. (MHz)	Reading (dBm)	S.G Power Value (dBm)	Correction Factor (dB)	EIRP (dBm)	Limit (dBm)	Margin (dB)
1	2537.50	-17.4	24.3	0.2	24.5	33.0	-8.5
Antenna Polarity & Test Distance: Vertical at 3 m							
No.	Freq. (MHz)	Reading (dBm)	S.G Power Value (dBm)	Correction Factor (dB)	EIRP (dBm)	Limit (dBm)	Margin (dB)
1	2537.50	-28.3	15.3	0.2	15.5	33.0	-17.5

MODE		TX channel 40640					
Antenna Polarity & Test Distance: Horizontal at 3 M							
No.	Freq. (MHz)	Reading (dBm)	S.G Power Value (dBm)	Correction Factor (dB)	EIRP (dBm)	Limit (dBm)	Margin (dB)
1	2595.00	-17.5	24.7	0.2	24.9	33.0	-8.1
Antenna Polarity & Test Distance: Vertical at 3 m							
No.	Freq. (MHz)	Reading (dBm)	S.G Power Value (dBm)	Correction Factor (dB)	EIRP (dBm)	Limit (dBm)	Margin (dB)
1	2595.00	-29.4	14.4	0.2	14.6	33.0	-18.4

MODE		TX channel 41215					
Antenna Polarity & Test Distance: Horizontal at 3 M							
No.	Freq. (MHz)	Reading (dBm)	S.G Power Value (dBm)	Correction Factor (dB)	EIRP (dBm)	Limit (dBm)	Margin (dB)
1	2652.50	-19.1	23.5	0.3	23.8	33.0	-9.2
Antenna Polarity & Test Distance: Vertical at 3 m							
No.	Freq. (MHz)	Reading (dBm)	S.G Power Value (dBm)	Correction Factor (dB)	EIRP (dBm)	Limit (dBm)	Margin (dB)
1	2652.50	-28.3	15.4	0.3	15.7	33.0	-17.3

Note: ERP (dBm) = S.G Power Value (dBm) + Correction Factor (dB).

Channel Bandwidth: 10MHz

MODE		TX channel 40090					
Antenna Polarity & Test Distance: Horizontal at 3 M							
No.	Freq. (MHz)	Reading (dBm)	S.G Power Value (dBm)	Correction Factor (dB)	EIRP (dBm)	Limit (dBm)	Margin (dB)
1	2540.00	-17.0	24.8	0.2	25.0	33.0	-8.0
Antenna Polarity & Test Distance: Vertical at 3 m							
No.	Freq. (MHz)	Reading (dBm)	S.G Power Value (dBm)	Correction Factor (dB)	EIRP (dBm)	Limit (dBm)	Margin (dB)
1	2540.00	-28.1	15.5	0.2	15.7	33.0	-17.3

MODE		TX channel 40640					
Antenna Polarity & Test Distance: Horizontal at 3 M							
No.	Freq. (MHz)	Reading (dBm)	S.G Power Value (dBm)	Correction Factor (dB)	EIRP (dBm)	Limit (dBm)	Margin (dB)
1	2595.00	-18.5	23.7	0.2	23.9	33.0	-9.1
Antenna Polarity & Test Distance: Vertical at 3 m							
No.	Freq. (MHz)	Reading (dBm)	S.G Power Value (dBm)	Correction Factor (dB)	EIRP (dBm)	Limit (dBm)	Margin (dB)
1	2595.00	-29.2	14.6	0.2	14.8	33.0	-18.2

MODE		TX channel 41190					
Antenna Polarity & Test Distance: Horizontal at 3 M							
No.	Freq. (MHz)	Reading (dBm)	S.G Power Value (dBm)	Correction Factor (dB)	EIRP (dBm)	Limit (dBm)	Margin (dB)
1	2650.00	-18.1	24.5	0.3	24.8	33.0	-8.2
Antenna Polarity & Test Distance: Vertical at 3 m							
No.	Freq. (MHz)	Reading (dBm)	S.G Power Value (dBm)	Correction Factor (dB)	EIRP (dBm)	Limit (dBm)	Margin (dB)
1	2650.00	-28.6	15.1	0.3	15.4	33.0	-17.6

Note: ERP (dBm) = S.G Power Value (dBm) + Correction Factor (dB).

Channel Bandwidth: 15MHz

MODE		TX channel 40115					
Antenna Polarity & Test Distance: Horizontal at 3 M							
No.	Freq. (MHz)	Reading (dBm)	S.G Power Value (dBm)	Correction Factor (dB)	EIRP (dBm)	Limit (dBm)	Margin (dB)
1	2542.50	-17.7	24.1	0.2	24.3	33.0	-8.7
Antenna Polarity & Test Distance: Vertical at 3 m							
No.	Freq. (MHz)	Reading (dBm)	S.G Power Value (dBm)	Correction Factor (dB)	EIRP (dBm)	Limit (dBm)	Margin (dB)
1	2542.50	-28.2	15.4	0.2	15.6	33.0	-17.4

MODE		TX channel 40640					
Antenna Polarity & Test Distance: Horizontal at 3 M							
No.	Freq. (MHz)	Reading (dBm)	S.G Power Value (dBm)	Correction Factor (dB)	EIRP (dBm)	Limit (dBm)	Margin (dB)
1	2595.00	-18.5	23.7	0.2	23.9	33.0	-9.1
Antenna Polarity & Test Distance: Vertical at 3 m							
No.	Freq. (MHz)	Reading (dBm)	S.G Power Value (dBm)	Correction Factor (dB)	EIRP (dBm)	Limit (dBm)	Margin (dB)
1	2595.00	-28.2	15.6	0.2	15.8	33.0	-17.2

MODE		TX channel 41165					
Antenna Polarity & Test Distance: Horizontal at 3 M							
No.	Freq. (MHz)	Reading (dBm)	S.G Power Value (dBm)	Correction Factor (dB)	EIRP (dBm)	Limit (dBm)	Margin (dB)
1	2647.50	-19.2	23.4	0.3	23.7	33.0	-9.3
Antenna Polarity & Test Distance: Vertical at 3 m							
No.	Freq. (MHz)	Reading (dBm)	S.G Power Value (dBm)	Correction Factor (dB)	EIRP (dBm)	Limit (dBm)	Margin (dB)
1	2647.50	-28.4	15.3	0.3	15.6	33.0	-17.4

Note: ERP (dBm) = S.G Power Value (dBm) + Correction Factor (dB).

Channel Bandwidth: 20MHz

MODE		TX channel 40140					
Antenna Polarity & Test Distance: Horizontal at 3 M							
No.	Freq. (MHz)	Reading (dBm)	S.G Power Value (dBm)	Correction Factor (dB)	EIRP (dBm)	Limit (dBm)	Margin (dB)
1	2545.00	-17.7	24.1	0.2	24.3	33.0	-8.7
Antenna Polarity & Test Distance: Vertical at 3 m							
No.	Freq. (MHz)	Reading (dBm)	S.G Power Value (dBm)	Correction Factor (dB)	EIRP (dBm)	Limit (dBm)	Margin (dB)
1	2545.00	-27.7	15.9	0.2	16.1	33.0	-16.9

MODE		TX channel 40640					
Antenna Polarity & Test Distance: Horizontal at 3 M							
No.	Freq. (MHz)	Reading (dBm)	S.G Power Value (dBm)	Correction Factor (dB)	EIRP (dBm)	Limit (dBm)	Margin (dB)
1	2595.00	-18.0	24.2	0.2	24.4	33.0	-8.6
Antenna Polarity & Test Distance: Vertical at 3 m							
No.	Freq. (MHz)	Reading (dBm)	S.G Power Value (dBm)	Correction Factor (dB)	EIRP (dBm)	Limit (dBm)	Margin (dB)
1	2595.00	-28.8	15.0	0.2	15.2	33.0	-17.8

MODE		TX channel 41140					
Antenna Polarity & Test Distance: Horizontal at 3 M							
No.	Freq. (MHz)	Reading (dBm)	S.G Power Value (dBm)	Correction Factor (dB)	EIRP (dBm)	Limit (dBm)	Margin (dB)
1	2645.00	-18.6	24.0	0.3	24.3	33.0	-8.7
Antenna Polarity & Test Distance: Vertical at 3 m							
No.	Freq. (MHz)	Reading (dBm)	S.G Power Value (dBm)	Correction Factor (dB)	EIRP (dBm)	Limit (dBm)	Margin (dB)
1	2645.00	-28.7	15.0	0.3	15.3	33.0	-17.7

Note: ERP (dBm) = S.G Power Value (dBm) + Correction Factor (dB).

LTE Band 66

Channel Bandwidth: 1.4MHz

MODE		TX channel 131979					
Antenna Polarity & Test Distance: Horizontal at 3 M							
No.	Freq. (MHz)	Reading (dBm)	S.G Power Value (dBm)	Correction Factor (dB)	EIRP (dBm)	Limit (dBm)	Margin (dB)
1	1710.70	-12.0	26.0	0.7	26.7	30.0	-3.3
Antenna Polarity & Test Distance: Vertical at 3 M							
No.	Freq. (MHz)	Reading (dBm)	S.G Power Value (dBm)	Correction Factor (dB)	EIRP (dBm)	Limit (dBm)	Margin (dB)
1	1710.70	-20.5	17.3	0.7	18.0	30.0	-12.0

MODE		TX channel 132322					
Antenna Polarity & Test Distance: Horizontal at 3 M							
No.	Freq. (MHz)	Reading (dBm)	S.G Power Value (dBm)	Correction Factor (dB)	EIRP (dBm)	Limit (dBm)	Margin (dB)
1	1745.00	-11.8	26.9	0.5	27.4	30.0	-2.6
Antenna Polarity & Test Distance: Vertical at 3 M							
No.	Freq. (MHz)	Reading (dBm)	S.G Power Value (dBm)	Correction Factor (dB)	EIRP (dBm)	Limit (dBm)	Margin (dB)
1	1745.00	-20.2	18.5	0.5	19.0	30.0	-11.0

MODE		TX channel 132665					
Antenna Polarity & Test Distance: Horizontal at 3 M							
No.	Freq. (MHz)	Reading (dBm)	S.G Power Value (dBm)	Correction Factor (dB)	EIRP (dBm)	Limit (dBm)	Margin (dB)
1	1779.30	-10.5	28.7	0.4	29.1	30.0	-0.9
Antenna Polarity & Test Distance: Vertical at 3 M							
No.	Freq. (MHz)	Reading (dBm)	S.G Power Value (dBm)	Correction Factor (dB)	EIRP (dBm)	Limit (dBm)	Margin (dB)
1	1779.30	-19.1	20.4	0.4	20.8	30.0	-9.2

Note: EIRP (dBm) = S.G Power Value (dBm) + Correction Factor (dB).

Channel Bandwidth: 3MHz

MODE		TX channel 131987					
Antenna Polarity & Test Distance: Horizontal at 3 M							
No.	Freq. (MHz)	Reading (dBm)	S.G Power Value (dBm)	Correction Factor (dB)	EIRP (dBm)	Limit (dBm)	Margin (dB)
1	1711.50	-11.7	26.3	0.7	27.0	30.0	-3.0
Antenna Polarity & Test Distance: Vertical at 3 M							
No.	Freq. (MHz)	Reading (dBm)	S.G Power Value (dBm)	Correction Factor (dB)	EIRP (dBm)	Limit (dBm)	Margin (dB)
1	1711.50	-19.9	17.9	0.7	18.6	30.0	-11.4

MODE		TX channel 132322					
Antenna Polarity & Test Distance: Horizontal at 3 M							
No.	Freq. (MHz)	Reading (dBm)	S.G Power Value (dBm)	Correction Factor (dB)	EIRP (dBm)	Limit (dBm)	Margin (dB)
1	1745.00	-11.5	27.2	0.5	27.7	30.0	-2.3
Antenna Polarity & Test Distance: Vertical at 3 M							
No.	Freq. (MHz)	Reading (dBm)	S.G Power Value (dBm)	Correction Factor (dB)	EIRP (dBm)	Limit (dBm)	Margin (dB)
1	1745.00	-19.5	19.2	0.5	19.7	30.0	-10.3

MODE		TX channel 132657					
Antenna Polarity & Test Distance: Horizontal at 3 M							
No.	Freq. (MHz)	Reading (dBm)	S.G Power Value (dBm)	Correction Factor (dB)	EIRP (dBm)	Limit (dBm)	Margin (dB)
1	1778.50	-10.3	28.9	0.4	29.3	30.0	-0.7
Antenna Polarity & Test Distance: Vertical at 3 M							
No.	Freq. (MHz)	Reading (dBm)	S.G Power Value (dBm)	Correction Factor (dB)	EIRP (dBm)	Limit (dBm)	Margin (dB)
1	1778.50	-18.6	20.9	0.4	21.3	30.0	-8.7

Note: EIRP (dBm) = S.G Power Value (dBm) + Correction Factor (dB).

Channel Bandwidth: 5MHz

MODE		TX channel 131997					
Antenna Polarity & Test Distance: Horizontal at 3 M							
No.	Freq. (MHz)	Reading (dBm)	S.G Power Value (dBm)	Correction Factor (dB)	EIRP (dBm)	Limit (dBm)	Margin (dB)
1	1712.50	-11.5	26.6	0.7	27.3	30.0	-2.7
Antenna Polarity & Test Distance: Vertical at 3 M							
No.	Freq. (MHz)	Reading (dBm)	S.G Power Value (dBm)	Correction Factor (dB)	EIRP (dBm)	Limit (dBm)	Margin (dB)
1	1712.50	-19.7	18.2	0.7	18.9	30.0	-11.1

MODE		TX channel 132322					
Antenna Polarity & Test Distance: Horizontal at 3 M							
No.	Freq. (MHz)	Reading (dBm)	S.G Power Value (dBm)	Correction Factor (dB)	EIRP (dBm)	Limit (dBm)	Margin (dB)
1	1745.00	-11.7	27.0	0.5	27.5	30.0	-2.5
Antenna Polarity & Test Distance: Vertical at 3 M							
No.	Freq. (MHz)	Reading (dBm)	S.G Power Value (dBm)	Correction Factor (dB)	EIRP (dBm)	Limit (dBm)	Margin (dB)
1	1745.00	-20.2	18.5	0.5	19.0	30.0	-11.0

MODE		TX channel 132647					
Antenna Polarity & Test Distance: Horizontal at 3 M							
No.	Freq. (MHz)	Reading (dBm)	S.G Power Value (dBm)	Correction Factor (dB)	EIRP (dBm)	Limit (dBm)	Margin (dB)
1	1777.50	-10.4	28.8	0.4	29.2	30.0	-0.8
Antenna Polarity & Test Distance: Vertical at 3 M							
No.	Freq. (MHz)	Reading (dBm)	S.G Power Value (dBm)	Correction Factor (dB)	EIRP (dBm)	Limit (dBm)	Margin (dB)
1	1777.50	-18.7	20.7	0.4	21.1	30.0	-8.9

Note: EIRP (dBm) = S.G Power Value (dBm) + Correction Factor (dB).

Channel Bandwidth: 10MHz

MODE		TX channel 132022					
Antenna Polarity & Test Distance: Horizontal at 3 M							
No.	Freq. (MHz)	Reading (dBm)	S.G Power Value (dBm)	Correction Factor (dB)	EIRP (dBm)	Limit (dBm)	Margin (dB)
1	1715.00	-11.4	26.7	0.7	27.4	30.0	-2.6
Antenna Polarity & Test Distance: Vertical at 3 M							
No.	Freq. (MHz)	Reading (dBm)	S.G Power Value (dBm)	Correction Factor (dB)	EIRP (dBm)	Limit (dBm)	Margin (dB)
1	1715.00	-19.7	18.2	0.7	18.9	30.0	-11.1

MODE		TX channel 132322					
Antenna Polarity & Test Distance: Horizontal at 3 M							
No.	Freq. (MHz)	Reading (dBm)	S.G Power Value (dBm)	Correction Factor (dB)	EIRP (dBm)	Limit (dBm)	Margin (dB)
1	1745.00	-11.6	27.1	0.5	27.6	30.0	-2.4
Antenna Polarity & Test Distance: Vertical at 3 M							
No.	Freq. (MHz)	Reading (dBm)	S.G Power Value (dBm)	Correction Factor (dB)	EIRP (dBm)	Limit (dBm)	Margin (dB)
1	1745.00	-20.0	18.7	0.5	19.2	30.0	-10.8

MODE		TX channel 132622					
Antenna Polarity & Test Distance: Horizontal at 3 M							
No.	Freq. (MHz)	Reading (dBm)	S.G Power Value (dBm)	Correction Factor (dB)	EIRP (dBm)	Limit (dBm)	Margin (dB)
1	1775.00	-10.4	28.8	0.4	29.2	30.0	-0.8
Antenna Polarity & Test Distance: Vertical at 3 M							
No.	Freq. (MHz)	Reading (dBm)	S.G Power Value (dBm)	Correction Factor (dB)	EIRP (dBm)	Limit (dBm)	Margin (dB)
1	1775.00	-19.1	20.3	0.4	20.7	30.0	-9.3

Note: EIRP (dBm) = S.G Power Value (dBm) + Correction Factor (dB).

Channel Bandwidth: 15MHz

MODE		TX channel 132047					
Antenna Polarity & Test Distance: Horizontal at 3 M							
No.	Freq. (MHz)	Reading (dBm)	S.G Power Value (dBm)	Correction Factor (dB)	EIRP (dBm)	Limit (dBm)	Margin (dB)
1	1717.50	-11.5	26.6	0.7	27.3	30.0	-2.7
Antenna Polarity & Test Distance: Vertical at 3 M							
No.	Freq. (MHz)	Reading (dBm)	S.G Power Value (dBm)	Correction Factor (dB)	EIRP (dBm)	Limit (dBm)	Margin (dB)
1	1717.50	-19.8	18.2	0.7	18.9	30.0	-11.1

MODE		TX channel 132322					
Antenna Polarity & Test Distance: Horizontal at 3 M							
No.	Freq. (MHz)	Reading (dBm)	S.G Power Value (dBm)	Correction Factor (dB)	EIRP (dBm)	Limit (dBm)	Margin (dB)
1	1745.00	-11.6	27.1	0.5	27.6	30.0	-2.4
Antenna Polarity & Test Distance: Vertical at 3 M							
No.	Freq. (MHz)	Reading (dBm)	S.G Power Value (dBm)	Correction Factor (dB)	EIRP (dBm)	Limit (dBm)	Margin (dB)
1	1745.00	-19.7	19.0	0.5	19.5	30.0	-10.5

MODE		TX channel 132597					
Antenna Polarity & Test Distance: Horizontal at 3 M							
No.	Freq. (MHz)	Reading (dBm)	S.G Power Value (dBm)	Correction Factor (dB)	EIRP (dBm)	Limit (dBm)	Margin (dB)
1	1772.50	-10.3	28.9	0.4	29.3	30.0	-0.7
Antenna Polarity & Test Distance: Vertical at 3 M							
No.	Freq. (MHz)	Reading (dBm)	S.G Power Value (dBm)	Correction Factor (dB)	EIRP (dBm)	Limit (dBm)	Margin (dB)
1	1772.50	-18.7	20.6	0.4	21.0	30.0	-9.0

Note: EIRP (dBm) = S.G Power Value (dBm) + Correction Factor (dB).

Channel Bandwidth: 20MHz

MODE		TX channel 132072					
Antenna Polarity & Test Distance: Horizontal at 3 M							
No.	Freq. (MHz)	Reading (dBm)	S.G Power Value (dBm)	Correction Factor (dB)	EIRP (dBm)	Limit (dBm)	Margin (dB)
1	1720.00	-11.5	26.7	0.7	27.4	30.0	-2.6
Antenna Polarity & Test Distance: Vertical at 3 M							
No.	Freq. (MHz)	Reading (dBm)	S.G Power Value (dBm)	Correction Factor (dB)	EIRP (dBm)	Limit (dBm)	Margin (dB)
1	1720.00	-19.4	18.6	0.7	19.3	30.0	-10.7

MODE		TX channel 132322					
Antenna Polarity & Test Distance: Horizontal at 3 M							
No.	Freq. (MHz)	Reading (dBm)	S.G Power Value (dBm)	Correction Factor (dB)	EIRP (dBm)	Limit (dBm)	Margin (dB)
1	1745.00	-11.9	26.8	0.5	27.3	30.0	-2.7
Antenna Polarity & Test Distance: Vertical at 3 M							
No.	Freq. (MHz)	Reading (dBm)	S.G Power Value (dBm)	Correction Factor (dB)	EIRP (dBm)	Limit (dBm)	Margin (dB)
1	1745.00	-20.3	18.4	0.5	18.9	30.0	-11.1

MODE		TX channel 132572					
Antenna Polarity & Test Distance: Horizontal at 3 M							
No.	Freq. (MHz)	Reading (dBm)	S.G Power Value (dBm)	Correction Factor (dB)	EIRP (dBm)	Limit (dBm)	Margin (dB)
1	1770.00	-10.6	28.4	0.5	28.9	30.0	-1.1
Antenna Polarity & Test Distance: Vertical at 3 M							
No.	Freq. (MHz)	Reading (dBm)	S.G Power Value (dBm)	Correction Factor (dB)	EIRP (dBm)	Limit (dBm)	Margin (dB)
1	1770.00	-18.8	20.4	0.5	20.9	30.0	-9.1

Note: EIRP (dBm) = S.G Power Value (dBm) + Correction Factor (dB).

Modulation Type: 16QAM

LTE Band 4

Channel Bandwidth: 1.4MHz

MODE		TX channel 19957					
Antenna Polarity & Test Distance: Horizontal at 3 M							
No.	Freq. (MHz)	Reading (dBm)	S.G Power Value (dBm)	Correction Factor (dB)	EIRP (dBm)	Limit (dBm)	Margin (dB)
1	1710.70	-16.5	21.5	0.7	22.2	30.0	-7.8
Antenna Polarity & Test Distance: Vertical at 3 M							
No.	Freq. (MHz)	Reading (dBm)	S.G Power Value (dBm)	Correction Factor (dB)	EIRP (dBm)	Limit (dBm)	Margin (dB)
1	1710.70	-21.4	16.4	0.7	17.1	30.0	-12.9

MODE		TX channel 20175					
Antenna Polarity & Test Distance: Horizontal at 3 M							
No.	Freq. (MHz)	Reading (dBm)	S.G Power Value (dBm)	Correction Factor (dB)	EIRP (dBm)	Limit (dBm)	Margin (dB)
1	1732.50	-16.6	21.8	0.6	22.4	30.0	-7.6
Antenna Polarity & Test Distance: Vertical at 3 M							
No.	Freq. (MHz)	Reading (dBm)	S.G Power Value (dBm)	Correction Factor (dB)	EIRP (dBm)	Limit (dBm)	Margin (dB)
1	1732.50	-21.5	16.8	0.6	17.4	30.0	-12.6

MODE		TX channel 20393					
Antenna Polarity & Test Distance: Horizontal at 3 M							
No.	Freq. (MHz)	Reading (dBm)	S.G Power Value (dBm)	Correction Factor (dB)	EIRP (dBm)	Limit (dBm)	Margin (dB)
1	1754.30	-16.4	22.4	0.5	22.9	30.0	-7.1
Antenna Polarity & Test Distance: Vertical at 3 M							
No.	Freq. (MHz)	Reading (dBm)	S.G Power Value (dBm)	Correction Factor (dB)	EIRP (dBm)	Limit (dBm)	Margin (dB)
1	1754.30	-21.2	17.7	0.5	18.2	30.0	-11.8

Note: $EIRP (dBm) = S.G \text{ Power Value (dBm)} + \text{Correction Factor (dB)}$.

Channel Bandwidth: 3MHz

MODE		TX channel 19965					
Antenna Polarity & Test Distance: Horizontal at 3 M							
No.	Freq. (MHz)	Reading (dBm)	S.G Power Value (dBm)	Correction Factor (dB)	EIRP (dBm)	Limit (dBm)	Margin (dB)
1	1711.50	-16.3	21.7	0.7	22.4	30.0	-7.6
Antenna Polarity & Test Distance: Vertical at 3 M							
No.	Freq. (MHz)	Reading (dBm)	S.G Power Value (dBm)	Correction Factor (dB)	EIRP (dBm)	Limit (dBm)	Margin (dB)
1	1711.50	-21.1	16.7	0.7	17.4	30.0	-12.6

MODE		TX channel 20175					
Antenna Polarity & Test Distance: Horizontal at 3 M							
No.	Freq. (MHz)	Reading (dBm)	S.G Power Value (dBm)	Correction Factor (dB)	EIRP (dBm)	Limit (dBm)	Margin (dB)
1	1732.50	-16.4	22.0	0.6	22.6	30.0	-7.4
Antenna Polarity & Test Distance: Vertical at 3 M							
No.	Freq. (MHz)	Reading (dBm)	S.G Power Value (dBm)	Correction Factor (dB)	EIRP (dBm)	Limit (dBm)	Margin (dB)
1	1732.50	-21.3	17.0	0.6	17.6	30.0	-12.4

MODE		TX channel 20385					
Antenna Polarity & Test Distance: Horizontal at 3 M							
No.	Freq. (MHz)	Reading (dBm)	S.G Power Value (dBm)	Correction Factor (dB)	EIRP (dBm)	Limit (dBm)	Margin (dB)
1	1753.50	-16.0	22.8	0.5	23.3	30.0	-6.7
Antenna Polarity & Test Distance: Vertical at 3 M							
No.	Freq. (MHz)	Reading (dBm)	S.G Power Value (dBm)	Correction Factor (dB)	EIRP (dBm)	Limit (dBm)	Margin (dB)
1	1753.50	-21.1	17.8	0.5	18.3	30.0	-11.7

Note: EIRP (dBm) = S.G Power Value (dBm) + Correction Factor (dB).

Channel Bandwidth: 5MHz

MODE		TX channel 19975					
Antenna Polarity & Test Distance: Horizontal at 3 M							
No.	Freq. (MHz)	Reading (dBm)	S.G Power Value (dBm)	Correction Factor (dB)	EIRP (dBm)	Limit (dBm)	Margin (dB)
1	1712.50	-16.4	21.7	0.7	22.4	30.0	-7.6
Antenna Polarity & Test Distance: Vertical at 3 M							
No.	Freq. (MHz)	Reading (dBm)	S.G Power Value (dBm)	Correction Factor (dB)	EIRP (dBm)	Limit (dBm)	Margin (dB)
1	1712.50	-21.3	16.6	0.7	17.3	30.0	-12.7

MODE		TX channel 20175					
Antenna Polarity & Test Distance: Horizontal at 3 M							
No.	Freq. (MHz)	Reading (dBm)	S.G Power Value (dBm)	Correction Factor (dB)	EIRP (dBm)	Limit (dBm)	Margin (dB)
1	1732.50	-16.2	22.2	0.6	22.8	30.0	-7.2
Antenna Polarity & Test Distance: Vertical at 3 M							
No.	Freq. (MHz)	Reading (dBm)	S.G Power Value (dBm)	Correction Factor (dB)	EIRP (dBm)	Limit (dBm)	Margin (dB)
1	1732.50	-21.2	17.1	0.6	17.7	30.0	-12.3

MODE		TX channel 20375					
Antenna Polarity & Test Distance: Horizontal at 3 M							
No.	Freq. (MHz)	Reading (dBm)	S.G Power Value (dBm)	Correction Factor (dB)	EIRP (dBm)	Limit (dBm)	Margin (dB)
1	1752.50	-16.3	22.5	0.5	23.0	30.0	-7.0
Antenna Polarity & Test Distance: Vertical at 3 M							
No.	Freq. (MHz)	Reading (dBm)	S.G Power Value (dBm)	Correction Factor (dB)	EIRP (dBm)	Limit (dBm)	Margin (dB)
1	1752.50	-21.2	17.6	0.5	18.1	30.0	-11.9

Note: EIRP (dBm) = S.G Power Value (dBm) + Correction Factor (dB).

Channel Bandwidth: 10MHz

MODE		TX channel 20000					
Antenna Polarity & Test Distance: Horizontal at 3 M							
No.	Freq. (MHz)	Reading (dBm)	S.G Power Value (dBm)	Correction Factor (dB)	EIRP (dBm)	Limit (dBm)	Margin (dB)
1	1715.00	-16.1	22.0	0.7	22.7	30.0	-7.3
Antenna Polarity & Test Distance: Vertical at 3 M							
No.	Freq. (MHz)	Reading (dBm)	S.G Power Value (dBm)	Correction Factor (dB)	EIRP (dBm)	Limit (dBm)	Margin (dB)
1	1715.00	-20.9	17.0	0.7	17.7	30.0	-12.3

MODE		TX channel 20175					
Antenna Polarity & Test Distance: Horizontal at 3 M							
No.	Freq. (MHz)	Reading (dBm)	S.G Power Value (dBm)	Correction Factor (dB)	EIRP (dBm)	Limit (dBm)	Margin (dB)
1	1732.50	-16.1	22.3	0.6	22.9	30.0	-7.1
Antenna Polarity & Test Distance: Vertical at 3 M							
No.	Freq. (MHz)	Reading (dBm)	S.G Power Value (dBm)	Correction Factor (dB)	EIRP (dBm)	Limit (dBm)	Margin (dB)
1	1732.50	-21.1	17.2	0.6	17.8	30.0	-12.2

MODE		TX channel 20350					
Antenna Polarity & Test Distance: Horizontal at 3 M							
No.	Freq. (MHz)	Reading (dBm)	S.G Power Value (dBm)	Correction Factor (dB)	EIRP (dBm)	Limit (dBm)	Margin (dB)
1	1750.00	-16.3	22.5	0.5	23.0	30.0	-7.0
Antenna Polarity & Test Distance: Vertical at 3 M							
No.	Freq. (MHz)	Reading (dBm)	S.G Power Value (dBm)	Correction Factor (dB)	EIRP (dBm)	Limit (dBm)	Margin (dB)
1	1750.00	-21.1	17.7	0.5	18.2	30.0	-11.8

Note: EIRP (dBm) = S.G Power Value (dBm) + Correction Factor (dB).

Channel Bandwidth: 15MHz

MODE		TX channel 20025					
Antenna Polarity & Test Distance: Horizontal at 3 M							
No.	Freq. (MHz)	Reading (dBm)	S.G Power Value (dBm)	Correction Factor (dB)	EIRP (dBm)	Limit (dBm)	Margin (dB)
1	1717.50	-16.1	22.0	0.7	22.7	30.0	-7.3
Antenna Polarity & Test Distance: Vertical at 3 M							
No.	Freq. (MHz)	Reading (dBm)	S.G Power Value (dBm)	Correction Factor (dB)	EIRP (dBm)	Limit (dBm)	Margin (dB)
1	1717.50	-21.0	17.0	0.7	17.7	30.0	-12.3

MODE		TX channel 20175					
Antenna Polarity & Test Distance: Horizontal at 3 M							
No.	Freq. (MHz)	Reading (dBm)	S.G Power Value (dBm)	Correction Factor (dB)	EIRP (dBm)	Limit (dBm)	Margin (dB)
1	1732.50	-16.1	22.3	0.6	22.9	30.0	-7.1
Antenna Polarity & Test Distance: Vertical at 3 M							
No.	Freq. (MHz)	Reading (dBm)	S.G Power Value (dBm)	Correction Factor (dB)	EIRP (dBm)	Limit (dBm)	Margin (dB)
1	1732.50	-21.0	17.3	0.6	17.9	30.0	-12.1

MODE		TX channel 20325					
Antenna Polarity & Test Distance: Horizontal at 3 M							
No.	Freq. (MHz)	Reading (dBm)	S.G Power Value (dBm)	Correction Factor (dB)	EIRP (dBm)	Limit (dBm)	Margin (dB)
1	1747.50	-15.8	22.9	0.5	23.4	30.0	-6.6
Antenna Polarity & Test Distance: Vertical at 3 M							
No.	Freq. (MHz)	Reading (dBm)	S.G Power Value (dBm)	Correction Factor (dB)	EIRP (dBm)	Limit (dBm)	Margin (dB)
1	1747.50	-20.7	18.0	0.5	18.5	30.0	-11.5

Note: EIRP (dBm) = S.G Power Value (dBm) + Correction Factor (dB).

Channel Bandwidth: 20MHz

MODE		TX channel 20050					
Antenna Polarity & Test Distance: Horizontal at 3 M							
No.	Freq. (MHz)	Reading (dBm)	S.G Power Value (dBm)	Correction Factor (dB)	EIRP (dBm)	Limit (dBm)	Margin (dB)
1	1720.00	-15.9	22.3	0.7	23.0	30.0	-7.0
Antenna Polarity & Test Distance: Vertical at 3 M							
No.	Freq. (MHz)	Reading (dBm)	S.G Power Value (dBm)	Correction Factor (dB)	EIRP (dBm)	Limit (dBm)	Margin (dB)
1	1720.00	-20.7	17.3	0.7	18.0	30.0	-12.0

MODE		TX channel 20175					
Antenna Polarity & Test Distance: Horizontal at 3 M							
No.	Freq. (MHz)	Reading (dBm)	S.G Power Value (dBm)	Correction Factor (dB)	EIRP (dBm)	Limit (dBm)	Margin (dB)
1	1732.50	-15.6	22.8	0.6	23.4	30.0	-6.6
Antenna Polarity & Test Distance: Vertical at 3 M							
No.	Freq. (MHz)	Reading (dBm)	S.G Power Value (dBm)	Correction Factor (dB)	EIRP (dBm)	Limit (dBm)	Margin (dB)
1	1732.50	-20.6	17.7	0.6	18.3	30.0	-11.7

MODE		TX channel 20300					
Antenna Polarity & Test Distance: Horizontal at 3 M							
No.	Freq. (MHz)	Reading (dBm)	S.G Power Value (dBm)	Correction Factor (dB)	EIRP (dBm)	Limit (dBm)	Margin (dB)
1	1745.00	-15.5	23.2	0.5	23.7	30.0	-6.3
Antenna Polarity & Test Distance: Vertical at 3 M							
No.	Freq. (MHz)	Reading (dBm)	S.G Power Value (dBm)	Correction Factor (dB)	EIRP (dBm)	Limit (dBm)	Margin (dB)
1	1745.00	-20.6	18.1	0.5	18.6	30.0	-11.4

Note: $EIRP (dBm) = S.G \text{ Power Value (dBm)} + \text{Correction Factor (dB)}$.

LTE Band 7

Channel Bandwidth: 5MHz

MODE		TX channel 20775					
Antenna Polarity & Test Distance: Horizontal at 3 M							
No.	Freq. (MHz)	Reading (dBm)	S.G Power Value (dBm)	Correction Factor (dB)	EIRP (dBm)	Limit (dBm)	Margin (dB)
1	2502.50	-21.5	20.0	0.2	20.2	33.0	-12.8
Antenna Polarity & Test Distance: Vertical at 3 M							
No.	Freq. (MHz)	Reading (dBm)	S.G Power Value (dBm)	Correction Factor (dB)	EIRP (dBm)	Limit (dBm)	Margin (dB)
1	2502.50	-31.1	12.4	0.2	12.6	33.0	-20.4

MODE		TX channel 21100					
Antenna Polarity & Test Distance: Horizontal at 3 M							
No.	Freq. (MHz)	Reading (dBm)	S.G Power Value (dBm)	Correction Factor (dB)	EIRP (dBm)	Limit (dBm)	Margin (dB)
1	2535.00	-21.9	19.8	0.2	20.0	33.0	-13.0
Antenna Polarity & Test Distance: Vertical at 3 M							
No.	Freq. (MHz)	Reading (dBm)	S.G Power Value (dBm)	Correction Factor (dB)	EIRP (dBm)	Limit (dBm)	Margin (dB)
1	2535.00	-30.8	12.8	0.2	13.0	33.0	-20.0

MODE		TX channel 21425					
Antenna Polarity & Test Distance: Horizontal at 3 M							
No.	Freq. (MHz)	Reading (dBm)	S.G Power Value (dBm)	Correction Factor (dB)	EIRP (dBm)	Limit (dBm)	Margin (dB)
1	2567.50	-21.3	20.7	0.2	20.9	33.0	-12.1
Antenna Polarity & Test Distance: Vertical at 3 M							
No.	Freq. (MHz)	Reading (dBm)	S.G Power Value (dBm)	Correction Factor (dB)	EIRP (dBm)	Limit (dBm)	Margin (dB)
1	2567.50	-30.5	13.2	0.2	13.4	33.0	-19.6

Note: EIRP (dBm) = S.G Power Value (dBm) + Correction Factor (dB).

Channel Bandwidth: 10MHz

MODE		TX channel 20800					
Antenna Polarity & Test Distance: Horizontal at 3 M							
No.	Freq. (MHz)	Reading (dBm)	S.G Power Value (dBm)	Correction Factor (dB)	EIRP (dBm)	Limit (dBm)	Margin (dB)
1	2505.00	-21.2	20.3	0.2	20.5	33.0	-12.5
Antenna Polarity & Test Distance: Vertical at 3 M							
No.	Freq. (MHz)	Reading (dBm)	S.G Power Value (dBm)	Correction Factor (dB)	EIRP (dBm)	Limit (dBm)	Margin (dB)
1	2505.00	-30.2	13.3	0.2	13.5	33.0	-19.5

MODE		TX channel 21100					
Antenna Polarity & Test Distance: Horizontal at 3 M							
No.	Freq. (MHz)	Reading (dBm)	S.G Power Value (dBm)	Correction Factor (dB)	EIRP (dBm)	Limit (dBm)	Margin (dB)
1	2535.00	-21.4	20.3	0.2	20.5	33.0	-12.5
Antenna Polarity & Test Distance: Vertical at 3 M							
No.	Freq. (MHz)	Reading (dBm)	S.G Power Value (dBm)	Correction Factor (dB)	EIRP (dBm)	Limit (dBm)	Margin (dB)
1	2535.00	-30.3	13.3	0.2	13.5	33.0	-19.5

MODE		TX channel 21400					
Antenna Polarity & Test Distance: Horizontal at 3 M							
No.	Freq. (MHz)	Reading (dBm)	S.G Power Value (dBm)	Correction Factor (dB)	EIRP (dBm)	Limit (dBm)	Margin (dB)
1	2565.00	-21.0	21.0	0.2	21.2	33.0	-11.8
Antenna Polarity & Test Distance: Vertical at 3 M							
No.	Freq. (MHz)	Reading (dBm)	S.G Power Value (dBm)	Correction Factor (dB)	EIRP (dBm)	Limit (dBm)	Margin (dB)
1	2565.00	-29.9	13.8	0.2	14.0	33.0	-19.0

Note: EIRP (dBm) = S.G Power Value (dBm) + Correction Factor (dB).

Channel Bandwidth: 15MHz

MODE		TX channel 20825					
Antenna Polarity & Test Distance: Horizontal at 3 M							
No.	Freq. (MHz)	Reading (dBm)	S.G Power Value (dBm)	Correction Factor (dB)	EIRP (dBm)	Limit (dBm)	Margin (dB)
1	2507.50	-20.9	20.6	0.2	20.8	33.0	-12.2
Antenna Polarity & Test Distance: Vertical at 3 M							
No.	Freq. (MHz)	Reading (dBm)	S.G Power Value (dBm)	Correction Factor (dB)	EIRP (dBm)	Limit (dBm)	Margin (dB)
1	2507.50	-29.9	13.6	0.2	13.8	33.0	-19.2

MODE		TX channel 21100					
Antenna Polarity & Test Distance: Horizontal at 3 M							
No.	Freq. (MHz)	Reading (dBm)	S.G Power Value (dBm)	Correction Factor (dB)	EIRP (dBm)	Limit (dBm)	Margin (dB)
1	2535.00	-21.1	20.6	0.2	20.8	33.0	-12.2
Antenna Polarity & Test Distance: Vertical at 3 M							
No.	Freq. (MHz)	Reading (dBm)	S.G Power Value (dBm)	Correction Factor (dB)	EIRP (dBm)	Limit (dBm)	Margin (dB)
1	2535.00	-30.0	13.6	0.2	13.8	33.0	-19.2

MODE		TX channel 21375					
Antenna Polarity & Test Distance: Horizontal at 3 M							
No.	Freq. (MHz)	Reading (dBm)	S.G Power Value (dBm)	Correction Factor (dB)	EIRP (dBm)	Limit (dBm)	Margin (dB)
1	2562.50	-20.7	21.3	0.2	21.5	33.0	-11.5
Antenna Polarity & Test Distance: Vertical at 3 M							
No.	Freq. (MHz)	Reading (dBm)	S.G Power Value (dBm)	Correction Factor (dB)	EIRP (dBm)	Limit (dBm)	Margin (dB)
1	2562.50	-29.7	14.0	0.2	14.2	33.0	-18.8

Note: EIRP (dBm) = S.G Power Value (dBm) + Correction Factor (dB).

Channel Bandwidth: 20MHz

MODE		TX channel 20850					
Antenna Polarity & Test Distance: Horizontal at 3 M							
No.	Freq. (MHz)	Reading (dBm)	S.G Power Value (dBm)	Correction Factor (dB)	EIRP (dBm)	Limit (dBm)	Margin (dB)
1	2510.00	-20.7	20.8	0.2	21.0	33.0	-12.0
Antenna Polarity & Test Distance: Vertical at 3 M							
No.	Freq. (MHz)	Reading (dBm)	S.G Power Value (dBm)	Correction Factor (dB)	EIRP (dBm)	Limit (dBm)	Margin (dB)
1	2510.00	-29.7	13.8	0.2	14.0	33.0	-19.0

MODE		TX channel 21100					
Antenna Polarity & Test Distance: Horizontal at 3 M							
No.	Freq. (MHz)	Reading (dBm)	S.G Power Value (dBm)	Correction Factor (dB)	EIRP (dBm)	Limit (dBm)	Margin (dB)
1	2535.00	-21.0	20.7	0.2	20.9	33.0	-12.1
Antenna Polarity & Test Distance: Vertical at 3 M							
No.	Freq. (MHz)	Reading (dBm)	S.G Power Value (dBm)	Correction Factor (dB)	EIRP (dBm)	Limit (dBm)	Margin (dB)
1	2535.00	-29.9	13.7	0.2	13.9	33.0	-19.1

MODE		TX channel 21350					
Antenna Polarity & Test Distance: Horizontal at 3 M							
No.	Freq. (MHz)	Reading (dBm)	S.G Power Value (dBm)	Correction Factor (dB)	EIRP (dBm)	Limit (dBm)	Margin (dB)
1	2560.00	-20.4	21.5	0.2	21.7	33.0	-11.3
Antenna Polarity & Test Distance: Vertical at 3 M							
No.	Freq. (MHz)	Reading (dBm)	S.G Power Value (dBm)	Correction Factor (dB)	EIRP (dBm)	Limit (dBm)	Margin (dB)
1	2560.00	-29.2	14.5	0.2	14.7	33.0	-18.3

Note: EIRP (dBm) = S.G Power Value (dBm) + Correction Factor (dB).

LTE Band 12

Channel Bandwidth: 1.4MHz

MODE		TX channel 23017					
Antenna Polarity & Test Distance: Horizontal at 3 M							
No.	Freq. (MHz)	Reading (dBm)	S.G Power Value (dBm)	Correction Factor (dB)	ERP (dBm)	Limit (dBm)	Margin (dB)
1	699.70	-18.7	5.8	3.5	9.3	34.8	-25.5
Antenna Polarity & Test Distance: Vertical at 3 M							
No.	Freq. (MHz)	Reading (dBm)	S.G Power Value (dBm)	Correction Factor (dB)	ERP (dBm)	Limit (dBm)	Margin (dB)
1	699.70	-15.0	12.5	3.5	16.0	34.8	-18.8

MODE		TX channel 23095					
Antenna Polarity & Test Distance: Horizontal at 3 M							
No.	Freq. (MHz)	Reading (dBm)	S.G Power Value (dBm)	Correction Factor (dB)	ERP (dBm)	Limit (dBm)	Margin (dB)
1	707.50	-17.9	6.9	3.5	10.4	34.8	-24.4
Antenna Polarity & Test Distance: Vertical at 3 M							
No.	Freq. (MHz)	Reading (dBm)	S.G Power Value (dBm)	Correction Factor (dB)	ERP (dBm)	Limit (dBm)	Margin (dB)
1	707.50	-12.6	15.1	3.5	18.6	34.8	-16.2

MODE		TX channel 23173					
Antenna Polarity & Test Distance: Horizontal at 3 M							
No.	Freq. (MHz)	Reading (dBm)	S.G Power Value (dBm)	Correction Factor (dB)	ERP (dBm)	Limit (dBm)	Margin (dB)
1	715.30	-18.9	6.1	3.5	9.6	34.8	-25.2
Antenna Polarity & Test Distance: Vertical at 3 M							
No.	Freq. (MHz)	Reading (dBm)	S.G Power Value (dBm)	Correction Factor (dB)	ERP (dBm)	Limit (dBm)	Margin (dB)
1	715.30	-12.9	14.7	3.5	18.2	34.8	-16.6

Note: ERP (dBm) = S.G Power Value (dBm) + Correction Factor (dB).

Channel Bandwidth: 3MHz

MODE		TX channel 23025					
Antenna Polarity & Test Distance: Horizontal at 3 M							
No.	Freq. (MHz)	Reading (dBm)	S.G Power Value (dBm)	Correction Factor (dB)	ERP (dBm)	Limit (dBm)	Margin (dB)
1	700.50	-18.1	6.4	3.5	9.9	34.8	-24.9
Antenna Polarity & Test Distance: Vertical at 3 M							
No.	Freq. (MHz)	Reading (dBm)	S.G Power Value (dBm)	Correction Factor (dB)	ERP (dBm)	Limit (dBm)	Margin (dB)
1	700.50	-12.8	14.8	3.5	18.3	34.8	-16.5

MODE		TX channel 23095					
Antenna Polarity & Test Distance: Horizontal at 3 M							
No.	Freq. (MHz)	Reading (dBm)	S.G Power Value (dBm)	Correction Factor (dB)	ERP (dBm)	Limit (dBm)	Margin (dB)
1	707.50	-18.2	6.5	3.5	10.0	34.8	-24.8
Antenna Polarity & Test Distance: Vertical at 3 M							
No.	Freq. (MHz)	Reading (dBm)	S.G Power Value (dBm)	Correction Factor (dB)	ERP (dBm)	Limit (dBm)	Margin (dB)
1	707.50	-12.9	14.9	3.5	18.4	34.8	-16.4

MODE		TX channel 23165					
Antenna Polarity & Test Distance: Horizontal at 3 M							
No.	Freq. (MHz)	Reading (dBm)	S.G Power Value (dBm)	Correction Factor (dB)	ERP (dBm)	Limit (dBm)	Margin (dB)
1	714.50	-18.6	6.4	3.5	9.9	34.8	-24.9
Antenna Polarity & Test Distance: Vertical at 3 M							
No.	Freq. (MHz)	Reading (dBm)	S.G Power Value (dBm)	Correction Factor (dB)	ERP (dBm)	Limit (dBm)	Margin (dB)
1	714.50	-12.8	14.8	3.5	18.3	34.8	-16.5

Note: ERP (dBm) = S.G Power Value (dBm) + Correction Factor (dB).

Channel Bandwidth: 5MHz

MODE		TX channel 23035					
Antenna Polarity & Test Distance: Horizontal at 3 M							
No.	Freq. (MHz)	Reading (dBm)	S.G Power Value (dBm)	Correction Factor (dB)	ERP (dBm)	Limit (dBm)	Margin (dB)
1	701.50	-18.2	6.4	3.4	9.8	34.8	-25.0
Antenna Polarity & Test Distance: Vertical at 3 M							
No.	Freq. (MHz)	Reading (dBm)	S.G Power Value (dBm)	Correction Factor (dB)	ERP (dBm)	Limit (dBm)	Margin (dB)
1	701.50	-12.8	14.9	3.4	18.3	34.8	-16.5

MODE		TX channel 23095					
Antenna Polarity & Test Distance: Horizontal at 3 M							
No.	Freq. (MHz)	Reading (dBm)	S.G Power Value (dBm)	Correction Factor (dB)	ERP (dBm)	Limit (dBm)	Margin (dB)
1	707.50	-19.1	5.7	3.5	9.2	34.8	-25.6
Antenna Polarity & Test Distance: Vertical at 3 M							
No.	Freq. (MHz)	Reading (dBm)	S.G Power Value (dBm)	Correction Factor (dB)	EIRP (dBm)	Limit (dBm)	Margin (dB)
1	707.50	-13.4	14.4	3.5	17.9	34.8	-16.9

MODE		TX channel 23155					
Antenna Polarity & Test Distance: Horizontal at 3 M							
No.	Freq. (MHz)	Reading (dBm)	S.G Power Value (dBm)	Correction Factor (dB)	ERP (dBm)	Limit (dBm)	Margin (dB)
1	713.50	-18.8	6.2	3.5	9.7	34.8	-25.1
Antenna Polarity & Test Distance: Vertical at 3 M							
No.	Freq. (MHz)	Reading (dBm)	S.G Power Value (dBm)	Correction Factor (dB)	EIRP (dBm)	Limit (dBm)	Margin (dB)
1	713.50	-13.1	14.6	3.5	18.1	34.8	-16.7

Note: ERP (dBm) = S.G Power Value (dBm) + Correction Factor (dB).

Channel Bandwidth: 10MHz

MODE		TX channel 23060					
Antenna Polarity & Test Distance: Horizontal at 3 M							
No.	Freq. (MHz)	Reading (dBm)	S.G Power Value (dBm)	Correction Factor (dB)	ERP (dBm)	Limit (dBm)	Margin (dB)
1	704.00	-18.4	6.3	3.5	9.8	34.8	-25.0
Antenna Polarity & Test Distance: Vertical at 3 M							
No.	Freq. (MHz)	Reading (dBm)	S.G Power Value (dBm)	Correction Factor (dB)	ERP (dBm)	Limit (dBm)	Margin (dB)
1	704.00	-12.8	14.8	3.5	18.3	34.8	-16.5

MODE		TX channel 23095					
Antenna Polarity & Test Distance: Horizontal at 3 M							
No.	Freq. (MHz)	Reading (dBm)	S.G Power Value (dBm)	Correction Factor (dB)	ERP (dBm)	Limit (dBm)	Margin (dB)
1	707.50	-18.6	6.2	3.5	9.7	34.8	-25.1
Antenna Polarity & Test Distance: Vertical at 3 M							
No.	Freq. (MHz)	Reading (dBm)	S.G Power Value (dBm)	Correction Factor (dB)	ERP (dBm)	Limit (dBm)	Margin (dB)
1	707.50	-12.9	14.9	3.5	18.4	34.8	-16.4

MODE		TX channel 23130					
Antenna Polarity & Test Distance: Horizontal at 3 M							
No.	Freq. (MHz)	Reading (dBm)	S.G Power Value (dBm)	Correction Factor (dB)	ERP (dBm)	Limit (dBm)	Margin (dB)
1	711.00	-19.1	5.9	3.5	9.4	34.8	-25.4
Antenna Polarity & Test Distance: Vertical at 3 M							
No.	Freq. (MHz)	Reading (dBm)	S.G Power Value (dBm)	Correction Factor (dB)	ERP (dBm)	Limit (dBm)	Margin (dB)
1	711.00	-13.3	14.3	3.5	17.8	34.8	-17.0

Note: ERP (dBm) = S.G Power Value (dBm) + Correction Factor (dB).

LTE Band 13

Channel Bandwidth: 5MHz

MODE		TX channel 23205					
Antenna Polarity & Test Distance: Horizontal at 3 M							
No.	Freq. (MHz)	Reading (dBm)	S.G Power Value (dBm)	Correction Factor (dB)	ERP (dBm)	Limit (dBm)	Margin (dB)
1	779.50	-19.2	6.8	4.0	10.8	34.8	-24.0
Antenna Polarity & Test Distance: Vertical at 3 M							
No.	Freq. (MHz)	Reading (dBm)	S.G Power Value (dBm)	Correction Factor (dB)	ERP (dBm)	Limit (dBm)	Margin (dB)
1	779.50	-13.9	14.2	4.0	18.2	34.8	-16.6

MODE		TX channel 23230					
Antenna Polarity & Test Distance: Horizontal at 3 M							
No.	Freq. (MHz)	Reading (dBm)	S.G Power Value (dBm)	Correction Factor (dB)	ERP (dBm)	Limit (dBm)	Margin (dB)
1	782.00	-19.3	6.7	4.0	10.7	34.8	-24.1
Antenna Polarity & Test Distance: Vertical at 3 M							
No.	Freq. (MHz)	Reading (dBm)	S.G Power Value (dBm)	Correction Factor (dB)	ERP (dBm)	Limit (dBm)	Margin (dB)
1	782.00	-13.8	14.1	4.0	18.1	34.8	-16.7

MODE		TX channel 23255					
Antenna Polarity & Test Distance: Horizontal at 3 M							
No.	Freq. (MHz)	Reading (dBm)	S.G Power Value (dBm)	Correction Factor (dB)	ERP (dBm)	Limit (dBm)	Margin (dB)
1	784.50	-18.5	7.6	4.0	11.6	34.8	-23.2
Antenna Polarity & Test Distance: Vertical at 3 M							
No.	Freq. (MHz)	Reading (dBm)	S.G Power Value (dBm)	Correction Factor (dB)	ERP (dBm)	Limit (dBm)	Margin (dB)
1	784.50	-13.9	14.0	4.0	18.0	34.8	-16.8

Note: ERP (dBm) = S.G Power Value (dBm) + Correction Factor (dB).

Channel Bandwidth: 10MHz

MODE		TX channel 23230					
Antenna Polarity & Test Distance: Horizontal at 3 M							
No.	Freq. (MHz)	Reading (dBm)	S.G Power Value (dBm)	Correction Factor (dB)	ERP (dBm)	Limit (dBm)	Margin (dB)
1	782.00	-19.1	6.9	4.0	10.9	34.8	-23.9
Antenna Polarity & Test Distance: Vertical at 3 M							
No.	Freq. (MHz)	Reading (dBm)	S.G Power Value (dBm)	Correction Factor (dB)	ERP (dBm)	Limit (dBm)	Margin (dB)
1	782.00	-13.8	14.1	4.0	18.1	34.8	-16.7

Note: ERP (dBm) = S.G Power Value (dBm) + Correction Factor (dB).

LTE Band 17

Channel Bandwidth: 5MHz

MODE		TX channel 23755					
Antenna Polarity & Test Distance: Horizontal at 3 M							
No.	Freq. (MHz)	Reading (dBm)	S.G Power Value (dBm)	Correction Factor (dB)	ERP (dBm)	Limit (dBm)	Margin (dB)
1	706.50	-18.1	6.7	3.5	10.2	34.8	-24.6
Antenna Polarity & Test Distance: Vertical at 3 M							
No.	Freq. (MHz)	Reading (dBm)	S.G Power Value (dBm)	Correction Factor (dB)	ERP (dBm)	Limit (dBm)	Margin (dB)
1	706.50	-13.8	13.8	3.5	17.3	34.8	-17.5

MODE		TX channel 23790					
Antenna Polarity & Test Distance: Horizontal at 3 M							
No.	Freq. (MHz)	Reading (dBm)	S.G Power Value (dBm)	Correction Factor (dB)	ERP (dBm)	Limit (dBm)	Margin (dB)
1	710.00	-18.2	6.7	3.5	10.2	34.8	-24.6
Antenna Polarity & Test Distance: Vertical at 3 M							
No.	Freq. (MHz)	Reading (dBm)	S.G Power Value (dBm)	Correction Factor (dB)	ERP (dBm)	Limit (dBm)	Margin (dB)
1	710.00	-13.7	13.9	3.5	17.4	34.8	-17.4

MODE		TX channel 23825					
Antenna Polarity & Test Distance: Horizontal at 3 M							
No.	Freq. (MHz)	Reading (dBm)	S.G Power Value (dBm)	Correction Factor (dB)	ERP (dBm)	Limit (dBm)	Margin (dB)
1	713.50	-18.4	6.6	3.5	10.1	34.8	-24.7
Antenna Polarity & Test Distance: Vertical at 3 M							
No.	Freq. (MHz)	Reading (dBm)	S.G Power Value (dBm)	Correction Factor (dB)	ERP (dBm)	Limit (dBm)	Margin (dB)
1	713.50	-14.1	13.6	3.5	17.1	34.8	-17.7

Note: ERP (dBm) = S.G Power Value (dBm) + Correction Factor (dB).

Channel Bandwidth: 10MHz

MODE		TX channel 23780					
Antenna Polarity & Test Distance: Horizontal at 3 M							
No.	Freq. (MHz)	Reading (dBm)	S.G Power Value (dBm)	Correction Factor (dB)	ERP (dBm)	Limit (dBm)	Margin (dB)
1	709.00	-17.9	6.9	3.5	10.4	34.8	-24.4
Antenna Polarity & Test Distance: Vertical at 3 M							
No.	Freq. (MHz)	Reading (dBm)	S.G Power Value (dBm)	Correction Factor (dB)	ERP (dBm)	Limit (dBm)	Margin (dB)
1	709.00	-14.1	13.5	3.5	17.0	34.8	-17.8

MODE		TX channel 23790					
Antenna Polarity & Test Distance: Horizontal at 3 M							
No.	Freq. (MHz)	Reading (dBm)	S.G Power Value (dBm)	Correction Factor (dB)	ERP (dBm)	Limit (dBm)	Margin (dB)
1	710.00	-18.2	6.6	3.5	10.1	34.8	-24.7
Antenna Polarity & Test Distance: Vertical at 3 M							
No.	Freq. (MHz)	Reading (dBm)	S.G Power Value (dBm)	Correction Factor (dB)	ERP (dBm)	Limit (dBm)	Margin (dB)
1	710.00	-13.9	13.7	3.5	17.2	34.8	-17.6

MODE		TX channel 23800					
Antenna Polarity & Test Distance: Horizontal at 3 M							
No.	Freq. (MHz)	Reading (dBm)	S.G Power Value (dBm)	Correction Factor (dB)	ERP (dBm)	Limit (dBm)	Margin (dB)
1	711.00	-18.5	6.5	3.5	10.0	34.8	-24.8
Antenna Polarity & Test Distance: Vertical at 3 M							
No.	Freq. (MHz)	Reading (dBm)	S.G Power Value (dBm)	Correction Factor (dB)	ERP (dBm)	Limit (dBm)	Margin (dB)
1	711.00	-13.9	13.7	3.5	17.2	34.8	-17.6

Note: ERP (dBm) = S.G Power Value (dBm) + Correction Factor (dB).

LTE Band 38

Channel Bandwidth: 5MHz

MODE		TX channel 37775					
Antenna Polarity & Test Distance: Horizontal at 3 M							
No.	Freq. (MHz)	Reading (dBm)	S.G Power Value (dBm)	Correction Factor (dB)	EIRP (dBm)	Limit (dBm)	Margin (dB)
1	2575.50	-18.6	23.4	0.2	23.6	33.0	-9.4
Antenna Polarity & Test Distance: Vertical at 3 M							
No.	Freq. (MHz)	Reading (dBm)	S.G Power Value (dBm)	Correction Factor (dB)	EIRP (dBm)	Limit (dBm)	Margin (dB)
1	2575.50	-26.2	17.5	0.2	17.7	33.0	-15.3

MODE		TX channel 38000					
Antenna Polarity & Test Distance: Horizontal at 3 M							
No.	Freq. (MHz)	Reading (dBm)	S.G Power Value (dBm)	Correction Factor (dB)	EIRP (dBm)	Limit (dBm)	Margin (dB)
1	2595.00	-18.3	23.9	0.2	24.1	33.0	-8.9
Antenna Polarity & Test Distance: Vertical at 3 M							
No.	Freq. (MHz)	Reading (dBm)	S.G Power Value (dBm)	Correction Factor (dB)	EIRP (dBm)	Limit (dBm)	Margin (dB)
1	2595.00	-26.2	17.6	0.2	17.8	33.0	-15.2

MODE		TX channel 38225					
Antenna Polarity & Test Distance: Horizontal at 3 M							
No.	Freq. (MHz)	Reading (dBm)	S.G Power Value (dBm)	Correction Factor (dB)	EIRP (dBm)	Limit (dBm)	Margin (dB)
1	2617.50	-19.2	23.2	0.2	23.4	33.0	-9.6
Antenna Polarity & Test Distance: Vertical at 3 M							
No.	Freq. (MHz)	Reading (dBm)	S.G Power Value (dBm)	Correction Factor (dB)	EIRP (dBm)	Limit (dBm)	Margin (dB)
1	2617.50	-26.7	17.1	0.2	17.3	33.0	-15.7

Note: EIRP (dBm) = S.G Power Value (dBm) + Correction Factor (dB).

Channel Bandwidth: 10MHz

MODE		TX channel 37800					
Antenna Polarity & Test Distance: Horizontal at 3 M							
No.	Freq. (MHz)	Reading (dBm)	S.G Power Value (dBm)	Correction Factor (dB)	EIRP (dBm)	Limit (dBm)	Margin (dB)
1	2575.00	-19.0	23.1	0.2	23.3	33.0	-9.7
Antenna Polarity & Test Distance: Vertical at 3 M							
No.	Freq. (MHz)	Reading (dBm)	S.G Power Value (dBm)	Correction Factor (dB)	EIRP (dBm)	Limit (dBm)	Margin (dB)
1	2575.00	-26.3	17.4	0.2	17.6	33.0	-15.4

MODE		TX channel 38000					
Antenna Polarity & Test Distance: Horizontal at 3 M							
No.	Freq. (MHz)	Reading (dBm)	S.G Power Value (dBm)	Correction Factor (dB)	EIRP (dBm)	Limit (dBm)	Margin (dB)
1	2595.00	-19.2	23.0	0.2	23.2	33.0	-9.8
Antenna Polarity & Test Distance: Vertical at 3 M							
No.	Freq. (MHz)	Reading (dBm)	S.G Power Value (dBm)	Correction Factor (dB)	EIRP (dBm)	Limit (dBm)	Margin (dB)
1	2595.00	-26.5	17.3	0.2	17.5	33.0	-15.5

MODE		TX channel 38200					
Antenna Polarity & Test Distance: Horizontal at 3 M							
No.	Freq. (MHz)	Reading (dBm)	S.G Power Value (dBm)	Correction Factor (dB)	EIRP (dBm)	Limit (dBm)	Margin (dB)
1	2615.00	-19.2	23.2	0.2	23.4	33.0	-9.6
Antenna Polarity & Test Distance: Vertical at 3 M							
No.	Freq. (MHz)	Reading (dBm)	S.G Power Value (dBm)	Correction Factor (dB)	EIRP (dBm)	Limit (dBm)	Margin (dB)
1	2615.00	-26.8	17.0	0.2	17.2	33.0	-15.8

Note: EIRP (dBm) = S.G Power Value (dBm) + Correction Factor (dB).

Channel Bandwidth: 15MHz

MODE		TX channel 37825					
Antenna Polarity & Test Distance: Horizontal at 3 M							
No.	Freq. (MHz)	Reading (dBm)	S.G Power Value (dBm)	Correction Factor (dB)	EIRP (dBm)	Limit (dBm)	Margin (dB)
1	2577.50	-18.7	23.4	0.2	23.6	33.0	-9.4
Antenna Polarity & Test Distance: Vertical at 3 M							
No.	Freq. (MHz)	Reading (dBm)	S.G Power Value (dBm)	Correction Factor (dB)	EIRP (dBm)	Limit (dBm)	Margin (dB)
1	2577.50	-26.3	17.4	0.2	17.6	33.0	-15.4

MODE		TX channel 38000					
Antenna Polarity & Test Distance: Horizontal at 3 M							
No.	Freq. (MHz)	Reading (dBm)	S.G Power Value (dBm)	Correction Factor (dB)	EIRP (dBm)	Limit (dBm)	Margin (dB)
1	2595.00	-18.6	23.6	0.2	23.8	33.0	-9.2
Antenna Polarity & Test Distance: Vertical at 3 M							
No.	Freq. (MHz)	Reading (dBm)	S.G Power Value (dBm)	Correction Factor (dB)	EIRP (dBm)	Limit (dBm)	Margin (dB)
1	2595.00	-26.6	17.2	0.2	17.4	33.0	-15.6

MODE		TX channel 38175					
Antenna Polarity & Test Distance: Horizontal at 3 M							
No.	Freq. (MHz)	Reading (dBm)	S.G Power Value (dBm)	Correction Factor (dB)	EIRP (dBm)	Limit (dBm)	Margin (dB)
1	2612.50	-18.8	23.6	0.2	23.8	33.0	-9.2
Antenna Polarity & Test Distance: Vertical at 3 M							
No.	Freq. (MHz)	Reading (dBm)	S.G Power Value (dBm)	Correction Factor (dB)	EIRP (dBm)	Limit (dBm)	Margin (dB)
1	2612.50	-26.2	17.6	0.2	17.8	33.0	-15.2

Note: EIRP (dBm) = S.G Power Value (dBm) + Correction Factor (dB).

Channel Bandwidth: 20MHz

MODE		TX channel 37850					
Antenna Polarity & Test Distance: Horizontal at 3 M							
No.	Freq. (MHz)	Reading (dBm)	S.G Power Value (dBm)	Correction Factor (dB)	EIRP (dBm)	Limit (dBm)	Margin (dB)
1	2580.00	-18.6	23.6	0.1	23.7	33.0	-9.3
Antenna Polarity & Test Distance: Vertical at 3 M							
No.	Freq. (MHz)	Reading (dBm)	S.G Power Value (dBm)	Correction Factor (dB)	EIRP (dBm)	Limit (dBm)	Margin (dB)
1	2580.00	-26.9	16.9	0.1	17.0	33.0	-16.0

MODE		TX channel 38000					
Antenna Polarity & Test Distance: Horizontal at 3 M							
No.	Freq. (MHz)	Reading (dBm)	S.G Power Value (dBm)	Correction Factor (dB)	EIRP (dBm)	Limit (dBm)	Margin (dB)
1	2595.00	-19.1	23.1	0.2	23.3	33.0	-9.7
Antenna Polarity & Test Distance: Vertical at 3 M							
No.	Freq. (MHz)	Reading (dBm)	S.G Power Value (dBm)	Correction Factor (dB)	EIRP (dBm)	Limit (dBm)	Margin (dB)
1	2595.00	-27.2	16.6	0.2	16.8	33.0	-16.2

MODE		TX channel 38150					
Antenna Polarity & Test Distance: Horizontal at 3 M							
No.	Freq. (MHz)	Reading (dBm)	S.G Power Value (dBm)	Correction Factor (dB)	EIRP (dBm)	Limit (dBm)	Margin (dB)
1	2610.00	-18.5	23.9	0.2	24.1	33.0	-8.9
Antenna Polarity & Test Distance: Vertical at 3 M							
No.	Freq. (MHz)	Reading (dBm)	S.G Power Value (dBm)	Correction Factor (dB)	EIRP (dBm)	Limit (dBm)	Margin (dB)
1	2610.00	-27.1	16.7	0.2	16.9	33.0	-16.1

Note: EIRP (dBm) = S.G Power Value (dBm) + Correction Factor (dB).

LTE Band 41

Channel Bandwidth: 5MHz

MODE		TX channel 40065					
Antenna Polarity & Test Distance: Horizontal at 3 M							
No.	Freq. (MHz)	Reading (dBm)	S.G Power Value (dBm)	Correction Factor (dB)	EIRP (dBm)	Limit (dBm)	Margin (dB)
1	2537.50	-18.4	23.3	0.2	23.5	33.0	-9.5
Antenna Polarity & Test Distance: Vertical at 3 m							
No.	Freq. (MHz)	Reading (dBm)	S.G Power Value (dBm)	Correction Factor (dB)	EIRP (dBm)	Limit (dBm)	Margin (dB)
1	2537.50	-29.2	14.4	0.2	14.6	33.0	-18.4

MODE		TX channel 40640					
Antenna Polarity & Test Distance: Horizontal at 3 M							
No.	Freq. (MHz)	Reading (dBm)	S.G Power Value (dBm)	Correction Factor (dB)	EIRP (dBm)	Limit (dBm)	Margin (dB)
1	2595.00	-18.5	23.7	0.2	23.9	33.0	-9.1
Antenna Polarity & Test Distance: Vertical at 3 m							
No.	Freq. (MHz)	Reading (dBm)	S.G Power Value (dBm)	Correction Factor (dB)	EIRP (dBm)	Limit (dBm)	Margin (dB)
1	2595.00	-30.3	13.5	0.2	13.7	33.0	-19.3

MODE		TX channel 41215					
Antenna Polarity & Test Distance: Horizontal at 3 M							
No.	Freq. (MHz)	Reading (dBm)	S.G Power Value (dBm)	Correction Factor (dB)	EIRP (dBm)	Limit (dBm)	Margin (dB)
1	2652.50	-19.8	22.8	0.3	23.1	33.0	-9.9
Antenna Polarity & Test Distance: Vertical at 3 m							
No.	Freq. (MHz)	Reading (dBm)	S.G Power Value (dBm)	Correction Factor (dB)	EIRP (dBm)	Limit (dBm)	Margin (dB)
1	2652.50	-29.0	14.7	0.3	15.0	33.0	-18.0

Note: ERP (dBm) = S.G Power Value (dBm) + Correction Factor (dB).

Channel Bandwidth: 10MHz

MODE		TX channel 40090					
Antenna Polarity & Test Distance: Horizontal at 3 M							
No.	Freq. (MHz)	Reading (dBm)	S.G Power Value (dBm)	Correction Factor (dB)	EIRP (dBm)	Limit (dBm)	Margin (dB)
1	2540.00	-17.6	24.2	0.2	24.4	33.0	-8.6
Antenna Polarity & Test Distance: Vertical at 3 m							
No.	Freq. (MHz)	Reading (dBm)	S.G Power Value (dBm)	Correction Factor (dB)	EIRP (dBm)	Limit (dBm)	Margin (dB)
1	2540.00	-28.7	14.9	0.2	15.1	33.0	-17.9

MODE		TX channel 40640					
Antenna Polarity & Test Distance: Horizontal at 3 M							
No.	Freq. (MHz)	Reading (dBm)	S.G Power Value (dBm)	Correction Factor (dB)	EIRP (dBm)	Limit (dBm)	Margin (dB)
1	2595.00	-19.2	23.0	0.2	23.2	33.0	-9.8
Antenna Polarity & Test Distance: Vertical at 3 m							
No.	Freq. (MHz)	Reading (dBm)	S.G Power Value (dBm)	Correction Factor (dB)	EIRP (dBm)	Limit (dBm)	Margin (dB)
1	2595.00	-29.8	14.0	0.2	14.2	33.0	-18.8

MODE		TX channel 41190					
Antenna Polarity & Test Distance: Horizontal at 3 M							
No.	Freq. (MHz)	Reading (dBm)	S.G Power Value (dBm)	Correction Factor (dB)	EIRP (dBm)	Limit (dBm)	Margin (dB)
1	2650.00	-18.9	23.7	0.3	24.0	33.0	-9.0
Antenna Polarity & Test Distance: Vertical at 3 m							
No.	Freq. (MHz)	Reading (dBm)	S.G Power Value (dBm)	Correction Factor (dB)	EIRP (dBm)	Limit (dBm)	Margin (dB)
1	2650.00	-29.1	14.6	0.3	14.9	33.0	-18.1

Note: ERP (dBm) = S.G Power Value (dBm) + Correction Factor (dB).

Channel Bandwidth: 15MHz

MODE		TX channel 40115					
Antenna Polarity & Test Distance: Horizontal at 3 M							
No.	Freq. (MHz)	Reading (dBm)	S.G Power Value (dBm)	Correction Factor (dB)	EIRP (dBm)	Limit (dBm)	Margin (dB)
1	2542.50	-18.7	23.1	0.2	23.3	33.0	-9.7
Antenna Polarity & Test Distance: Vertical at 3 m							
No.	Freq. (MHz)	Reading (dBm)	S.G Power Value (dBm)	Correction Factor (dB)	EIRP (dBm)	Limit (dBm)	Margin (dB)
1	2542.50	-28.8	14.8	0.2	15.0	33.0	-18.0

MODE		TX channel 40640					
Antenna Polarity & Test Distance: Horizontal at 3 M							
No.	Freq. (MHz)	Reading (dBm)	S.G Power Value (dBm)	Correction Factor (dB)	EIRP (dBm)	Limit (dBm)	Margin (dB)
1	2595.00	-19.2	23.0	0.2	23.2	33.0	-9.8
Antenna Polarity & Test Distance: Vertical at 3 m							
No.	Freq. (MHz)	Reading (dBm)	S.G Power Value (dBm)	Correction Factor (dB)	EIRP (dBm)	Limit (dBm)	Margin (dB)
1	2595.00	-28.8	15.0	0.2	15.2	33.0	-17.8

MODE		TX channel 41165					
Antenna Polarity & Test Distance: Horizontal at 3 M							
No.	Freq. (MHz)	Reading (dBm)	S.G Power Value (dBm)	Correction Factor (dB)	EIRP (dBm)	Limit (dBm)	Margin (dB)
1	2647.50	-19.9	22.7	0.3	23.0	33.0	-10.0
Antenna Polarity & Test Distance: Vertical at 3 m							
No.	Freq. (MHz)	Reading (dBm)	S.G Power Value (dBm)	Correction Factor (dB)	EIRP (dBm)	Limit (dBm)	Margin (dB)
1	2647.50	-29.0	14.7	0.3	15.0	33.0	-18.0

Note: ERP (dBm) = S.G Power Value (dBm) + Correction Factor (dB).

Channel Bandwidth: 20MHz

MODE		TX channel 40140					
Antenna Polarity & Test Distance: Horizontal at 3 M							
No.	Freq. (MHz)	Reading (dBm)	S.G Power Value (dBm)	Correction Factor (dB)	EIRP (dBm)	Limit (dBm)	Margin (dB)
1	2545.00	-18.7	23.1	0.2	23.3	33.0	-9.7
Antenna Polarity & Test Distance: Vertical at 3 m							
No.	Freq. (MHz)	Reading (dBm)	S.G Power Value (dBm)	Correction Factor (dB)	EIRP (dBm)	Limit (dBm)	Margin (dB)
1	2545.00	-28.6	15.0	0.2	15.2	33.0	-17.8

MODE		TX channel 40640					
Antenna Polarity & Test Distance: Horizontal at 3 M							
No.	Freq. (MHz)	Reading (dBm)	S.G Power Value (dBm)	Correction Factor (dB)	EIRP (dBm)	Limit (dBm)	Margin (dB)
1	2595.00	-18.9	23.3	0.2	23.5	33.0	-9.5
Antenna Polarity & Test Distance: Vertical at 3 m							
No.	Freq. (MHz)	Reading (dBm)	S.G Power Value (dBm)	Correction Factor (dB)	EIRP (dBm)	Limit (dBm)	Margin (dB)
1	2595.00	-29.6	14.2	0.2	14.4	33.0	-18.6

MODE		TX channel 41140					
Antenna Polarity & Test Distance: Horizontal at 3 M							
No.	Freq. (MHz)	Reading (dBm)	S.G Power Value (dBm)	Correction Factor (dB)	EIRP (dBm)	Limit (dBm)	Margin (dB)
1	2645.00	-19.4	23.2	0.3	23.5	33.0	-9.5
Antenna Polarity & Test Distance: Vertical at 3 m							
No.	Freq. (MHz)	Reading (dBm)	S.G Power Value (dBm)	Correction Factor (dB)	EIRP (dBm)	Limit (dBm)	Margin (dB)
1	2645.00	-29.2	14.5	0.3	14.8	33.0	-18.2

Note: ERP (dBm) = S.G Power Value (dBm) + Correction Factor (dB).

LTE Band 66

Channel Bandwidth: 1.4MHz

MODE		TX channel 131979					
Antenna Polarity & Test Distance: Horizontal at 3 M							
No.	Freq. (MHz)	Reading (dBm)	S.G Power Value (dBm)	Correction Factor (dB)	EIRP (dBm)	Limit (dBm)	Margin (dB)
1	1710.70	-12.9	25.1	0.7	25.8	30.0	-4.2
Antenna Polarity & Test Distance: Vertical at 3 M							
No.	Freq. (MHz)	Reading (dBm)	S.G Power Value (dBm)	Correction Factor (dB)	EIRP (dBm)	Limit (dBm)	Margin (dB)
1	1710.70	-21.4	16.4	0.7	17.1	30.0	-12.9

MODE		TX channel 132322					
Antenna Polarity & Test Distance: Horizontal at 3 M							
No.	Freq. (MHz)	Reading (dBm)	S.G Power Value (dBm)	Correction Factor (dB)	EIRP (dBm)	Limit (dBm)	Margin (dB)
1	1745.00	-12.7	26.0	0.5	26.5	30.0	-3.5
Antenna Polarity & Test Distance: Vertical at 3 M							
No.	Freq. (MHz)	Reading (dBm)	S.G Power Value (dBm)	Correction Factor (dB)	EIRP (dBm)	Limit (dBm)	Margin (dB)
1	1745.00	-21.1	17.6	0.5	18.1	30.0	-11.9

MODE		TX channel 132665					
Antenna Polarity & Test Distance: Horizontal at 3 M							
No.	Freq. (MHz)	Reading (dBm)	S.G Power Value (dBm)	Correction Factor (dB)	EIRP (dBm)	Limit (dBm)	Margin (dB)
1	1779.30	-11.5	27.7	0.4	28.1	30.0	-1.9
Antenna Polarity & Test Distance: Vertical at 3 M							
No.	Freq. (MHz)	Reading (dBm)	S.G Power Value (dBm)	Correction Factor (dB)	EIRP (dBm)	Limit (dBm)	Margin (dB)
1	1779.30	-20.1	19.4	0.4	19.8	30.0	-10.2

Note: EIRP (dBm) = S.G Power Value (dBm) + Correction Factor (dB).

Channel Bandwidth: 3MHz

MODE		TX channel 131987					
Antenna Polarity & Test Distance: Horizontal at 3 M							
No.	Freq. (MHz)	Reading (dBm)	S.G Power Value (dBm)	Correction Factor (dB)	EIRP (dBm)	Limit (dBm)	Margin (dB)
1	1711.50	-12.5	25.5	0.7	26.2	30.0	-3.8
Antenna Polarity & Test Distance: Vertical at 3 M							
No.	Freq. (MHz)	Reading (dBm)	S.G Power Value (dBm)	Correction Factor (dB)	EIRP (dBm)	Limit (dBm)	Margin (dB)
1	1711.50	-20.8	17.0	0.7	17.7	30.0	-12.3

MODE		TX channel 132322					
Antenna Polarity & Test Distance: Horizontal at 3 M							
No.	Freq. (MHz)	Reading (dBm)	S.G Power Value (dBm)	Correction Factor (dB)	EIRP (dBm)	Limit (dBm)	Margin (dB)
1	1745.00	-12.4	26.3	0.5	26.8	30.0	-3.2
Antenna Polarity & Test Distance: Vertical at 3 M							
No.	Freq. (MHz)	Reading (dBm)	S.G Power Value (dBm)	Correction Factor (dB)	EIRP (dBm)	Limit (dBm)	Margin (dB)
1	1745.00	-20.5	18.2	0.5	18.7	30.0	-11.3

MODE		TX channel 132657					
Antenna Polarity & Test Distance: Horizontal at 3 M							
No.	Freq. (MHz)	Reading (dBm)	S.G Power Value (dBm)	Correction Factor (dB)	EIRP (dBm)	Limit (dBm)	Margin (dB)
1	1778.50	-11.2	28.0	0.4	28.4	30.0	-1.6
Antenna Polarity & Test Distance: Vertical at 3 M							
No.	Freq. (MHz)	Reading (dBm)	S.G Power Value (dBm)	Correction Factor (dB)	EIRP (dBm)	Limit (dBm)	Margin (dB)
1	1778.50	-19.5	20.0	0.4	20.4	30.0	-9.6

Note: EIRP (dBm) = S.G Power Value (dBm) + Correction Factor (dB).

Channel Bandwidth: 5MHz

MODE		TX channel 131997					
Antenna Polarity & Test Distance: Horizontal at 3 M							
No.	Freq. (MHz)	Reading (dBm)	S.G Power Value (dBm)	Correction Factor (dB)	EIRP (dBm)	Limit (dBm)	Margin (dB)
1	1712.50	-12.5	25.6	0.7	26.3	30.0	-3.7
Antenna Polarity & Test Distance: Vertical at 3 M							
No.	Freq. (MHz)	Reading (dBm)	S.G Power Value (dBm)	Correction Factor (dB)	EIRP (dBm)	Limit (dBm)	Margin (dB)
1	1712.50	-20.6	17.3	0.7	18.0	30.0	-12.0

MODE		TX channel 132322					
Antenna Polarity & Test Distance: Horizontal at 3 M							
No.	Freq. (MHz)	Reading (dBm)	S.G Power Value (dBm)	Correction Factor (dB)	EIRP (dBm)	Limit (dBm)	Margin (dB)
1	1745.00	-12.7	26.0	0.5	26.5	30.0	-3.5
Antenna Polarity & Test Distance: Vertical at 3 M							
No.	Freq. (MHz)	Reading (dBm)	S.G Power Value (dBm)	Correction Factor (dB)	EIRP (dBm)	Limit (dBm)	Margin (dB)
1	1745.00	-21.1	17.6	0.5	18.1	30.0	-11.9

MODE		TX channel 132647					
Antenna Polarity & Test Distance: Horizontal at 3 M							
No.	Freq. (MHz)	Reading (dBm)	S.G Power Value (dBm)	Correction Factor (dB)	EIRP (dBm)	Limit (dBm)	Margin (dB)
1	1777.50	-11.3	27.9	0.4	28.3	30.0	-1.7
Antenna Polarity & Test Distance: Vertical at 3 M							
No.	Freq. (MHz)	Reading (dBm)	S.G Power Value (dBm)	Correction Factor (dB)	EIRP (dBm)	Limit (dBm)	Margin (dB)
1	1777.50	-19.6	19.8	0.4	20.2	30.0	-9.8

Note: EIRP (dBm) = S.G Power Value (dBm) + Correction Factor (dB).

Channel Bandwidth: 10MHz

MODE		TX channel 132022					
Antenna Polarity & Test Distance: Horizontal at 3 M							
No.	Freq. (MHz)	Reading (dBm)	S.G Power Value (dBm)	Correction Factor (dB)	EIRP (dBm)	Limit (dBm)	Margin (dB)
1	1715.00	-12.5	25.6	0.7	26.3	30.0	-3.7
Antenna Polarity & Test Distance: Vertical at 3 M							
No.	Freq. (MHz)	Reading (dBm)	S.G Power Value (dBm)	Correction Factor (dB)	EIRP (dBm)	Limit (dBm)	Margin (dB)
1	1715.00	-20.8	17.1	0.7	17.8	30.0	-12.2

MODE		TX channel 132322					
Antenna Polarity & Test Distance: Horizontal at 3 M							
No.	Freq. (MHz)	Reading (dBm)	S.G Power Value (dBm)	Correction Factor (dB)	EIRP (dBm)	Limit (dBm)	Margin (dB)
1	1745.00	-12.6	26.1	0.5	26.6	30.0	-3.4
Antenna Polarity & Test Distance: Vertical at 3 M							
No.	Freq. (MHz)	Reading (dBm)	S.G Power Value (dBm)	Correction Factor (dB)	EIRP (dBm)	Limit (dBm)	Margin (dB)
1	1745.00	-21.0	17.7	0.5	18.2	30.0	-11.8

MODE		TX channel 132622					
Antenna Polarity & Test Distance: Horizontal at 3 M							
No.	Freq. (MHz)	Reading (dBm)	S.G Power Value (dBm)	Correction Factor (dB)	EIRP (dBm)	Limit (dBm)	Margin (dB)
1	1775.00	-11.3	27.9	0.4	28.3	30.0	-1.7
Antenna Polarity & Test Distance: Vertical at 3 M							
No.	Freq. (MHz)	Reading (dBm)	S.G Power Value (dBm)	Correction Factor (dB)	EIRP (dBm)	Limit (dBm)	Margin (dB)
1	1775.00	-20.1	19.3	0.4	19.7	30.0	-10.3

Note: EIRP (dBm) = S.G Power Value (dBm) + Correction Factor (dB).

Channel Bandwidth: 15MHz

MODE		TX channel 132047					
Antenna Polarity & Test Distance: Horizontal at 3 M							
No.	Freq. (MHz)	Reading (dBm)	S.G Power Value (dBm)	Correction Factor (dB)	EIRP (dBm)	Limit (dBm)	Margin (dB)
1	1717.50	-12.6	25.5	0.7	26.2	30.0	-3.8
Antenna Polarity & Test Distance: Vertical at 3 M							
No.	Freq. (MHz)	Reading (dBm)	S.G Power Value (dBm)	Correction Factor (dB)	EIRP (dBm)	Limit (dBm)	Margin (dB)
1	1717.50	-20.9	17.1	0.7	17.8	30.0	-12.2

MODE		TX channel 132322					
Antenna Polarity & Test Distance: Horizontal at 3 M							
No.	Freq. (MHz)	Reading (dBm)	S.G Power Value (dBm)	Correction Factor (dB)	EIRP (dBm)	Limit (dBm)	Margin (dB)
1	1745.00	-12.5	26.2	0.5	26.7	30.0	-3.3
Antenna Polarity & Test Distance: Vertical at 3 M							
No.	Freq. (MHz)	Reading (dBm)	S.G Power Value (dBm)	Correction Factor (dB)	EIRP (dBm)	Limit (dBm)	Margin (dB)
1	1745.00	-20.6	18.1	0.5	18.6	30.0	-11.4

MODE		TX channel 132597					
Antenna Polarity & Test Distance: Horizontal at 3 M							
No.	Freq. (MHz)	Reading (dBm)	S.G Power Value (dBm)	Correction Factor (dB)	EIRP (dBm)	Limit (dBm)	Margin (dB)
1	1772.50	-11.3	27.9	0.4	28.3	30.0	-1.7
Antenna Polarity & Test Distance: Vertical at 3 M							
No.	Freq. (MHz)	Reading (dBm)	S.G Power Value (dBm)	Correction Factor (dB)	EIRP (dBm)	Limit (dBm)	Margin (dB)
1	1772.50	-19.6	19.7	0.4	20.1	30.0	-9.9

Note: EIRP (dBm) = S.G Power Value (dBm) + Correction Factor (dB).

Channel Bandwidth: 20MHz

MODE		TX channel 132072					
Antenna Polarity & Test Distance: Horizontal at 3 M							
No.	Freq. (MHz)	Reading (dBm)	S.G Power Value (dBm)	Correction Factor (dB)	EIRP (dBm)	Limit (dBm)	Margin (dB)
1	1720.00	-12.7	25.5	0.7	26.2	30.0	-3.8
Antenna Polarity & Test Distance: Vertical at 3 M							
No.	Freq. (MHz)	Reading (dBm)	S.G Power Value (dBm)	Correction Factor (dB)	EIRP (dBm)	Limit (dBm)	Margin (dB)
1	1720.00	-20.6	17.4	0.7	18.1	30.0	-11.9

MODE		TX channel 132322					
Antenna Polarity & Test Distance: Horizontal at 3 M							
No.	Freq. (MHz)	Reading (dBm)	S.G Power Value (dBm)	Correction Factor (dB)	EIRP (dBm)	Limit (dBm)	Margin (dB)
1	1745.00	-12.9	25.8	0.5	26.3	30.0	-3.7
Antenna Polarity & Test Distance: Vertical at 3 M							
No.	Freq. (MHz)	Reading (dBm)	S.G Power Value (dBm)	Correction Factor (dB)	EIRP (dBm)	Limit (dBm)	Margin (dB)
1	1745.00	-21.3	17.4	0.5	17.9	30.0	-12.1

MODE		TX channel 132572					
Antenna Polarity & Test Distance: Horizontal at 3 M							
No.	Freq. (MHz)	Reading (dBm)	S.G Power Value (dBm)	Correction Factor (dB)	EIRP (dBm)	Limit (dBm)	Margin (dB)
1	1770.00	-11.5	27.5	0.5	28.0	30.0	-2.0
Antenna Polarity & Test Distance: Vertical at 3 M							
No.	Freq. (MHz)	Reading (dBm)	S.G Power Value (dBm)	Correction Factor (dB)	EIRP (dBm)	Limit (dBm)	Margin (dB)
1	1770.00	-19.7	19.5	0.5	20.0	30.0	-10.0

Note: EIRP (dBm) = S.G Power Value (dBm) + Correction Factor (dB).

Modulation Type: 64QAM

LTE Band 4

Channel Bandwidth: 1.4MHz

MODE		TX channel 19957					
Antenna Polarity & Test Distance: Horizontal at 3 M							
No.	Freq. (MHz)	Reading (dBm)	S.G Power Value (dBm)	Correction Factor (dB)	EIRP (dBm)	Limit (dBm)	Margin (dB)
1	1710.70	-16.6	21.4	0.7	22.1	30.0	-7.9
Antenna Polarity & Test Distance: Vertical at 3 M							
No.	Freq. (MHz)	Reading (dBm)	S.G Power Value (dBm)	Correction Factor (dB)	EIRP (dBm)	Limit (dBm)	Margin (dB)
1	1710.70	-21.4	16.4	0.7	17.1	30.0	-12.9

MODE		TX channel 20175					
Antenna Polarity & Test Distance: Horizontal at 3 M							
No.	Freq. (MHz)	Reading (dBm)	S.G Power Value (dBm)	Correction Factor (dB)	EIRP (dBm)	Limit (dBm)	Margin (dB)
1	1732.50	-16.7	21.7	0.6	22.3	30.0	-7.7
Antenna Polarity & Test Distance: Vertical at 3 M							
No.	Freq. (MHz)	Reading (dBm)	S.G Power Value (dBm)	Correction Factor (dB)	EIRP (dBm)	Limit (dBm)	Margin (dB)
1	1732.50	-20.9	17.4	0.6	18.0	30.0	-12.0

MODE		TX channel 20393					
Antenna Polarity & Test Distance: Horizontal at 3 M							
No.	Freq. (MHz)	Reading (dBm)	S.G Power Value (dBm)	Correction Factor (dB)	EIRP (dBm)	Limit (dBm)	Margin (dB)
1	1754.30	-16.5	22.3	0.5	22.8	30.0	-7.2
Antenna Polarity & Test Distance: Vertical at 3 M							
No.	Freq. (MHz)	Reading (dBm)	S.G Power Value (dBm)	Correction Factor (dB)	EIRP (dBm)	Limit (dBm)	Margin (dB)
1	1754.30	-20.4	18.5	0.5	19.0	30.0	-11.0

Note: $EIRP (dBm) = S.G \text{ Power Value (dBm)} + \text{Correction Factor (dB)}$.

Channel Bandwidth: 3MHz

MODE		TX channel 19965					
Antenna Polarity & Test Distance: Horizontal at 3 M							
No.	Freq. (MHz)	Reading (dBm)	S.G Power Value (dBm)	Correction Factor (dB)	EIRP (dBm)	Limit (dBm)	Margin (dB)
1	1711.50	-16.5	21.5	0.7	22.2	30.0	-7.8
Antenna Polarity & Test Distance: Vertical at 3 M							
No.	Freq. (MHz)	Reading (dBm)	S.G Power Value (dBm)	Correction Factor (dB)	EIRP (dBm)	Limit (dBm)	Margin (dB)
1	1711.50	-20.7	17.1	0.7	17.8	30.0	-12.2

MODE		TX channel 20175					
Antenna Polarity & Test Distance: Horizontal at 3 M							
No.	Freq. (MHz)	Reading (dBm)	S.G Power Value (dBm)	Correction Factor (dB)	EIRP (dBm)	Limit (dBm)	Margin (dB)
1	1732.50	-16.5	21.9	0.6	22.5	30.0	-7.5
Antenna Polarity & Test Distance: Vertical at 3 M							
No.	Freq. (MHz)	Reading (dBm)	S.G Power Value (dBm)	Correction Factor (dB)	EIRP (dBm)	Limit (dBm)	Margin (dB)
1	1732.50	-20.8	17.5	0.6	18.1	30.0	-11.9

MODE		TX channel 20385					
Antenna Polarity & Test Distance: Horizontal at 3 M							
No.	Freq. (MHz)	Reading (dBm)	S.G Power Value (dBm)	Correction Factor (dB)	EIRP (dBm)	Limit (dBm)	Margin (dB)
1	1753.50	-16.1	22.7	0.5	23.2	30.0	-6.8
Antenna Polarity & Test Distance: Vertical at 3 M							
No.	Freq. (MHz)	Reading (dBm)	S.G Power Value (dBm)	Correction Factor (dB)	EIRP (dBm)	Limit (dBm)	Margin (dB)
1	1753.50	-20.5	18.4	0.5	18.9	30.0	-11.1

Note: EIRP (dBm) = S.G Power Value (dBm) + Correction Factor (dB).

Channel Bandwidth: 5MHz

MODE		TX channel 19975					
Antenna Polarity & Test Distance: Horizontal at 3 M							
No.	Freq. (MHz)	Reading (dBm)	S.G Power Value (dBm)	Correction Factor (dB)	EIRP (dBm)	Limit (dBm)	Margin (dB)
1	1712.50	-16.6	21.5	0.7	22.2	30.0	-7.8
Antenna Polarity & Test Distance: Vertical at 3 M							
No.	Freq. (MHz)	Reading (dBm)	S.G Power Value (dBm)	Correction Factor (dB)	EIRP (dBm)	Limit (dBm)	Margin (dB)
1	1712.50	-21.0	16.9	0.7	17.6	30.0	-12.4

MODE		TX channel 20175					
Antenna Polarity & Test Distance: Horizontal at 3 M							
No.	Freq. (MHz)	Reading (dBm)	S.G Power Value (dBm)	Correction Factor (dB)	EIRP (dBm)	Limit (dBm)	Margin (dB)
1	1732.50	-16.4	22.0	0.6	22.6	30.0	-7.4
Antenna Polarity & Test Distance: Vertical at 3 M							
No.	Freq. (MHz)	Reading (dBm)	S.G Power Value (dBm)	Correction Factor (dB)	EIRP (dBm)	Limit (dBm)	Margin (dB)
1	1732.50	-21.0	17.3	0.6	17.9	30.0	-12.1

MODE		TX channel 20375					
Antenna Polarity & Test Distance: Horizontal at 3 M							
No.	Freq. (MHz)	Reading (dBm)	S.G Power Value (dBm)	Correction Factor (dB)	EIRP (dBm)	Limit (dBm)	Margin (dB)
1	1752.50	-16.5	22.3	0.5	22.8	30.0	-7.2
Antenna Polarity & Test Distance: Vertical at 3 M							
No.	Freq. (MHz)	Reading (dBm)	S.G Power Value (dBm)	Correction Factor (dB)	EIRP (dBm)	Limit (dBm)	Margin (dB)
1	1752.50	-20.5	18.3	0.5	18.8	30.0	-11.2

Note: EIRP (dBm) = S.G Power Value (dBm) + Correction Factor (dB).

Channel Bandwidth: 10MHz

MODE		TX channel 20000					
Antenna Polarity & Test Distance: Horizontal at 3 M							
No.	Freq. (MHz)	Reading (dBm)	S.G Power Value (dBm)	Correction Factor (dB)	EIRP (dBm)	Limit (dBm)	Margin (dB)
1	1715.00	-16.2	21.9	0.7	22.6	30.0	-7.4
Antenna Polarity & Test Distance: Vertical at 3 M							
No.	Freq. (MHz)	Reading (dBm)	S.G Power Value (dBm)	Correction Factor (dB)	EIRP (dBm)	Limit (dBm)	Margin (dB)
1	1715.00	-20.6	17.3	0.7	18.0	30.0	-12.0

MODE		TX channel 20175					
Antenna Polarity & Test Distance: Horizontal at 3 M							
No.	Freq. (MHz)	Reading (dBm)	S.G Power Value (dBm)	Correction Factor (dB)	EIRP (dBm)	Limit (dBm)	Margin (dB)
1	1732.50	-16.2	22.2	0.6	22.8	30.0	-7.2
Antenna Polarity & Test Distance: Vertical at 3 M							
No.	Freq. (MHz)	Reading (dBm)	S.G Power Value (dBm)	Correction Factor (dB)	EIRP (dBm)	Limit (dBm)	Margin (dB)
1	1732.50	-20.7	17.6	0.6	18.2	30.0	-11.8

MODE		TX channel 20350					
Antenna Polarity & Test Distance: Horizontal at 3 M							
No.	Freq. (MHz)	Reading (dBm)	S.G Power Value (dBm)	Correction Factor (dB)	EIRP (dBm)	Limit (dBm)	Margin (dB)
1	1750.00	-16.4	22.4	0.5	22.9	30.0	-7.1
Antenna Polarity & Test Distance: Vertical at 3 M							
No.	Freq. (MHz)	Reading (dBm)	S.G Power Value (dBm)	Correction Factor (dB)	EIRP (dBm)	Limit (dBm)	Margin (dB)
1	1750.00	-20.6	18.2	0.5	18.7	30.0	-11.3

Note: $EIRP (dBm) = S.G \text{ Power Value (dBm)} + \text{Correction Factor (dB)}$.

Channel Bandwidth: 15MHz

MODE		TX channel 20025					
Antenna Polarity & Test Distance: Horizontal at 3 M							
No.	Freq. (MHz)	Reading (dBm)	S.G Power Value (dBm)	Correction Factor (dB)	EIRP (dBm)	Limit (dBm)	Margin (dB)
1	1717.50	-16.2	21.9	0.7	22.6	30.0	-7.4
Antenna Polarity & Test Distance: Vertical at 3 M							
No.	Freq. (MHz)	Reading (dBm)	S.G Power Value (dBm)	Correction Factor (dB)	EIRP (dBm)	Limit (dBm)	Margin (dB)
1	1717.50	-20.6	17.4	0.7	18.1	30.0	-11.9

MODE		TX channel 20175					
Antenna Polarity & Test Distance: Horizontal at 3 M							
No.	Freq. (MHz)	Reading (dBm)	S.G Power Value (dBm)	Correction Factor (dB)	EIRP (dBm)	Limit (dBm)	Margin (dB)
1	1732.50	-16.3	22.1	0.6	22.7	30.0	-7.3
Antenna Polarity & Test Distance: Vertical at 3 M							
No.	Freq. (MHz)	Reading (dBm)	S.G Power Value (dBm)	Correction Factor (dB)	EIRP (dBm)	Limit (dBm)	Margin (dB)
1	1732.50	-20.5	17.8	0.6	18.4	30.0	-11.6

MODE		TX channel 20325					
Antenna Polarity & Test Distance: Horizontal at 3 M							
No.	Freq. (MHz)	Reading (dBm)	S.G Power Value (dBm)	Correction Factor (dB)	EIRP (dBm)	Limit (dBm)	Margin (dB)
1	1747.50	-16.0	22.7	0.5	23.2	30.0	-6.8
Antenna Polarity & Test Distance: Vertical at 3 M							
No.	Freq. (MHz)	Reading (dBm)	S.G Power Value (dBm)	Correction Factor (dB)	EIRP (dBm)	Limit (dBm)	Margin (dB)
1	1747.50	-20.4	18.3	0.5	18.8	30.0	-11.2

Note: EIRP (dBm) = S.G Power Value (dBm) + Correction Factor (dB).

Channel Bandwidth: 20MHz

MODE		TX channel 20050					
Antenna Polarity & Test Distance: Horizontal at 3 M							
No.	Freq. (MHz)	Reading (dBm)	S.G Power Value (dBm)	Correction Factor (dB)	EIRP (dBm)	Limit (dBm)	Margin (dB)
1	1720.00	-16.8	21.4	0.7	22.1	30.0	-7.9
Antenna Polarity & Test Distance: Vertical at 3 M							
No.	Freq. (MHz)	Reading (dBm)	S.G Power Value (dBm)	Correction Factor (dB)	EIRP (dBm)	Limit (dBm)	Margin (dB)
1	1720.00	-20.2	17.8	0.7	18.5	30.0	-11.5

MODE		TX channel 20175					
Antenna Polarity & Test Distance: Horizontal at 3 M							
No.	Freq. (MHz)	Reading (dBm)	S.G Power Value (dBm)	Correction Factor (dB)	EIRP (dBm)	Limit (dBm)	Margin (dB)
1	1732.50	-15.8	22.6	0.6	23.2	30.0	-6.8
Antenna Polarity & Test Distance: Vertical at 3 M							
No.	Freq. (MHz)	Reading (dBm)	S.G Power Value (dBm)	Correction Factor (dB)	EIRP (dBm)	Limit (dBm)	Margin (dB)
1	1732.50	-20.2	18.1	0.6	18.7	30.0	-11.3

MODE		TX channel 20300					
Antenna Polarity & Test Distance: Horizontal at 3 M							
No.	Freq. (MHz)	Reading (dBm)	S.G Power Value (dBm)	Correction Factor (dB)	EIRP (dBm)	Limit (dBm)	Margin (dB)
1	1745.00	-15.6	23.1	0.5	23.6	30.0	-6.4
Antenna Polarity & Test Distance: Vertical at 3 M							
No.	Freq. (MHz)	Reading (dBm)	S.G Power Value (dBm)	Correction Factor (dB)	EIRP (dBm)	Limit (dBm)	Margin (dB)
1	1745.00	-20.3	18.4	0.5	18.9	30.0	-11.1

Note: EIRP (dBm) = S.G Power Value (dBm) + Correction Factor (dB).

LTE Band 7

Channel Bandwidth: 5MHz

MODE		TX channel 20775					
Antenna Polarity & Test Distance: Horizontal at 3 M							
No.	Freq. (MHz)	Reading (dBm)	S.G Power Value (dBm)	Correction Factor (dB)	EIRP (dBm)	Limit (dBm)	Margin (dB)
1	2502.50	-21.7	19.8	0.2	20.0	33.0	-13.0
Antenna Polarity & Test Distance: Vertical at 3 M							
No.	Freq. (MHz)	Reading (dBm)	S.G Power Value (dBm)	Correction Factor (dB)	EIRP (dBm)	Limit (dBm)	Margin (dB)
1	2502.50	-31.4	12.1	0.2	12.3	33.0	-20.7

MODE		TX channel 21100					
Antenna Polarity & Test Distance: Horizontal at 3 M							
No.	Freq. (MHz)	Reading (dBm)	S.G Power Value (dBm)	Correction Factor (dB)	EIRP (dBm)	Limit (dBm)	Margin (dB)
1	2535.00	-22.2	19.5	0.2	19.7	33.0	-13.3
Antenna Polarity & Test Distance: Vertical at 3 M							
No.	Freq. (MHz)	Reading (dBm)	S.G Power Value (dBm)	Correction Factor (dB)	EIRP (dBm)	Limit (dBm)	Margin (dB)
1	2535.00	-31.0	12.6	0.2	12.8	33.0	-20.2

MODE		TX channel 21425					
Antenna Polarity & Test Distance: Horizontal at 3 M							
No.	Freq. (MHz)	Reading (dBm)	S.G Power Value (dBm)	Correction Factor (dB)	EIRP (dBm)	Limit (dBm)	Margin (dB)
1	2567.50	-21.8	20.2	0.2	20.4	33.0	-12.6
Antenna Polarity & Test Distance: Vertical at 3 M							
No.	Freq. (MHz)	Reading (dBm)	S.G Power Value (dBm)	Correction Factor (dB)	EIRP (dBm)	Limit (dBm)	Margin (dB)
1	2567.50	-30.7	13.0	0.2	13.2	33.0	-19.8

Note: EIRP (dBm) = S.G Power Value (dBm) + Correction Factor (dB).

Channel Bandwidth: 10MHz

MODE		TX channel 20800					
Antenna Polarity & Test Distance: Horizontal at 3 M							
No.	Freq. (MHz)	Reading (dBm)	S.G Power Value (dBm)	Correction Factor (dB)	EIRP (dBm)	Limit (dBm)	Margin (dB)
1	2505.00	-21.5	20.0	0.2	20.2	33.0	-12.8
Antenna Polarity & Test Distance: Vertical at 3 M							
No.	Freq. (MHz)	Reading (dBm)	S.G Power Value (dBm)	Correction Factor (dB)	EIRP (dBm)	Limit (dBm)	Margin (dB)
1	2505.00	-30.5	13.0	0.2	13.2	33.0	-19.8

MODE		TX channel 21100					
Antenna Polarity & Test Distance: Horizontal at 3 M							
No.	Freq. (MHz)	Reading (dBm)	S.G Power Value (dBm)	Correction Factor (dB)	EIRP (dBm)	Limit (dBm)	Margin (dB)
1	2535.00	-21.8	19.9	0.2	20.1	33.0	-12.9
Antenna Polarity & Test Distance: Vertical at 3 M							
No.	Freq. (MHz)	Reading (dBm)	S.G Power Value (dBm)	Correction Factor (dB)	EIRP (dBm)	Limit (dBm)	Margin (dB)
1	2535.00	-30.7	12.9	0.2	13.1	33.0	-19.9

MODE		TX channel 21400					
Antenna Polarity & Test Distance: Horizontal at 3 M							
No.	Freq. (MHz)	Reading (dBm)	S.G Power Value (dBm)	Correction Factor (dB)	EIRP (dBm)	Limit (dBm)	Margin (dB)
1	2565.00	-21.2	20.8	0.2	21.0	33.0	-12.0
Antenna Polarity & Test Distance: Vertical at 3 M							
No.	Freq. (MHz)	Reading (dBm)	S.G Power Value (dBm)	Correction Factor (dB)	EIRP (dBm)	Limit (dBm)	Margin (dB)
1	2565.00	-30.2	13.5	0.2	13.7	33.0	-19.3

Note: EIRP (dBm) = S.G Power Value (dBm) + Correction Factor (dB).

Channel Bandwidth: 15MHz

MODE		TX channel 20825					
Antenna Polarity & Test Distance: Horizontal at 3 M							
No.	Freq. (MHz)	Reading (dBm)	S.G Power Value (dBm)	Correction Factor (dB)	EIRP (dBm)	Limit (dBm)	Margin (dB)
1	2507.50	-21.2	20.3	0.2	20.5	33.0	-12.5
Antenna Polarity & Test Distance: Vertical at 3 M							
No.	Freq. (MHz)	Reading (dBm)	S.G Power Value (dBm)	Correction Factor (dB)	EIRP (dBm)	Limit (dBm)	Margin (dB)
1	2507.50	-30.1	13.4	0.2	13.6	33.0	-19.4

MODE		TX channel 21100					
Antenna Polarity & Test Distance: Horizontal at 3 M							
No.	Freq. (MHz)	Reading (dBm)	S.G Power Value (dBm)	Correction Factor (dB)	EIRP (dBm)	Limit (dBm)	Margin (dB)
1	2535.00	-21.5	20.2	0.2	20.4	33.0	-12.6
Antenna Polarity & Test Distance: Vertical at 3 M							
No.	Freq. (MHz)	Reading (dBm)	S.G Power Value (dBm)	Correction Factor (dB)	EIRP (dBm)	Limit (dBm)	Margin (dB)
1	2535.00	-30.3	13.3	0.2	13.5	33.0	-19.5

MODE		TX channel 21375					
Antenna Polarity & Test Distance: Horizontal at 3 M							
No.	Freq. (MHz)	Reading (dBm)	S.G Power Value (dBm)	Correction Factor (dB)	EIRP (dBm)	Limit (dBm)	Margin (dB)
1	2562.50	-21.0	21.0	0.2	21.2	33.0	-11.8
Antenna Polarity & Test Distance: Vertical at 3 M							
No.	Freq. (MHz)	Reading (dBm)	S.G Power Value (dBm)	Correction Factor (dB)	EIRP (dBm)	Limit (dBm)	Margin (dB)
1	2562.50	-29.9	13.8	0.2	14.0	33.0	-19.0

Note: EIRP (dBm) = S.G Power Value (dBm) + Correction Factor (dB).

Channel Bandwidth: 20MHz

MODE		TX channel 20850					
Antenna Polarity & Test Distance: Horizontal at 3 M							
No.	Freq. (MHz)	Reading (dBm)	S.G Power Value (dBm)	Correction Factor (dB)	EIRP (dBm)	Limit (dBm)	Margin (dB)
1	2510.00	-20.9	20.6	0.2	20.8	33.0	-12.2
Antenna Polarity & Test Distance: Vertical at 3 M							
No.	Freq. (MHz)	Reading (dBm)	S.G Power Value (dBm)	Correction Factor (dB)	EIRP (dBm)	Limit (dBm)	Margin (dB)
1	2510.00	-29.9	13.6	0.2	13.8	33.0	-19.2

MODE		TX channel 21100					
Antenna Polarity & Test Distance: Horizontal at 3 M							
No.	Freq. (MHz)	Reading (dBm)	S.G Power Value (dBm)	Correction Factor (dB)	EIRP (dBm)	Limit (dBm)	Margin (dB)
1	2535.00	-21.2	20.5	0.2	20.7	33.0	-12.3
Antenna Polarity & Test Distance: Vertical at 3 M							
No.	Freq. (MHz)	Reading (dBm)	S.G Power Value (dBm)	Correction Factor (dB)	EIRP (dBm)	Limit (dBm)	Margin (dB)
1	2535.00	-30.2	13.4	0.2	13.6	33.0	-19.4

MODE		TX channel 21350					
Antenna Polarity & Test Distance: Horizontal at 3 M							
No.	Freq. (MHz)	Reading (dBm)	S.G Power Value (dBm)	Correction Factor (dB)	EIRP (dBm)	Limit (dBm)	Margin (dB)
1	2560.00	-20.7	21.2	0.2	21.4	33.0	-11.6
Antenna Polarity & Test Distance: Vertical at 3 M							
No.	Freq. (MHz)	Reading (dBm)	S.G Power Value (dBm)	Correction Factor (dB)	EIRP (dBm)	Limit (dBm)	Margin (dB)
1	2560.00	-29.6	14.1	0.2	14.3	33.0	-18.7

Note: EIRP (dBm) = S.G Power Value (dBm) + Correction Factor (dB).

LTE Band 12

Channel Bandwidth: 1.4MHz

MODE		TX channel 23017					
Antenna Polarity & Test Distance: Horizontal at 3 M							
No.	Freq. (MHz)	Reading (dBm)	S.G Power Value (dBm)	Correction Factor (dB)	ERP (dBm)	Limit (dBm)	Margin (dB)
1	699.70	-18.9	5.6	3.5	9.1	34.8	-25.7
Antenna Polarity & Test Distance: Vertical at 3 M							
No.	Freq. (MHz)	Reading (dBm)	S.G Power Value (dBm)	Correction Factor (dB)	ERP (dBm)	Limit (dBm)	Margin (dB)
1	699.70	-15.1	12.4	3.5	15.9	34.8	-18.9

MODE		TX channel 23095					
Antenna Polarity & Test Distance: Horizontal at 3 M							
No.	Freq. (MHz)	Reading (dBm)	S.G Power Value (dBm)	Correction Factor (dB)	ERP (dBm)	Limit (dBm)	Margin (dB)
1	707.50	-18.1	6.7	3.5	10.2	34.8	-24.6
Antenna Polarity & Test Distance: Vertical at 3 M							
No.	Freq. (MHz)	Reading (dBm)	S.G Power Value (dBm)	Correction Factor (dB)	ERP (dBm)	Limit (dBm)	Margin (dB)
1	707.50	-12.9	14.9	3.5	18.4	34.8	-16.4

MODE		TX channel 23173					
Antenna Polarity & Test Distance: Horizontal at 3 M							
No.	Freq. (MHz)	Reading (dBm)	S.G Power Value (dBm)	Correction Factor (dB)	ERP (dBm)	Limit (dBm)	Margin (dB)
1	715.30	-19.1	5.9	3.5	9.4	34.8	-25.4
Antenna Polarity & Test Distance: Vertical at 3 M							
No.	Freq. (MHz)	Reading (dBm)	S.G Power Value (dBm)	Correction Factor (dB)	ERP (dBm)	Limit (dBm)	Margin (dB)
1	715.30	-13.0	14.6	3.5	18.1	34.8	-16.7

Note: ERP (dBm) = S.G Power Value (dBm) + Correction Factor (dB).

Channel Bandwidth: 3MHz

MODE		TX channel 23025					
Antenna Polarity & Test Distance: Horizontal at 3 M							
No.	Freq. (MHz)	Reading (dBm)	S.G Power Value (dBm)	Correction Factor (dB)	ERP (dBm)	Limit (dBm)	Margin (dB)
1	700.50	-18.4	6.1	3.5	9.6	34.8	-25.2
Antenna Polarity & Test Distance: Vertical at 3 M							
No.	Freq. (MHz)	Reading (dBm)	S.G Power Value (dBm)	Correction Factor (dB)	ERP (dBm)	Limit (dBm)	Margin (dB)
1	700.50	-12.9	14.7	3.5	18.2	34.8	-16.6

MODE		TX channel 23095					
Antenna Polarity & Test Distance: Horizontal at 3 M							
No.	Freq. (MHz)	Reading (dBm)	S.G Power Value (dBm)	Correction Factor (dB)	ERP (dBm)	Limit (dBm)	Margin (dB)
1	707.50	-18.4	6.3	3.5	9.8	34.8	-25.0
Antenna Polarity & Test Distance: Vertical at 3 M							
No.	Freq. (MHz)	Reading (dBm)	S.G Power Value (dBm)	Correction Factor (dB)	ERP (dBm)	Limit (dBm)	Margin (dB)
1	707.50	-13.1	14.6	3.5	18.1	34.8	-16.7

MODE		TX channel 23165					
Antenna Polarity & Test Distance: Horizontal at 3 M							
No.	Freq. (MHz)	Reading (dBm)	S.G Power Value (dBm)	Correction Factor (dB)	ERP (dBm)	Limit (dBm)	Margin (dB)
1	714.50	-18.9	6.1	3.5	9.6	34.8	-25.2
Antenna Polarity & Test Distance: Vertical at 3 M							
No.	Freq. (MHz)	Reading (dBm)	S.G Power Value (dBm)	Correction Factor (dB)	ERP (dBm)	Limit (dBm)	Margin (dB)
1	714.50	-12.9	14.7	3.5	18.2	34.8	-16.6

Note: ERP (dBm) = S.G Power Value (dBm) + Correction Factor (dB).

Channel Bandwidth: 5MHz

MODE		TX channel 23035					
Antenna Polarity & Test Distance: Horizontal at 3 M							
No.	Freq. (MHz)	Reading (dBm)	S.G Power Value (dBm)	Correction Factor (dB)	ERP (dBm)	Limit (dBm)	Margin (dB)
1	701.50	-18.5	6.1	3.4	9.5	34.8	-25.3
Antenna Polarity & Test Distance: Vertical at 3 M							
No.	Freq. (MHz)	Reading (dBm)	S.G Power Value (dBm)	Correction Factor (dB)	ERP (dBm)	Limit (dBm)	Margin (dB)
1	701.50	-13.0	14.7	3.4	18.1	34.8	-16.7

MODE		TX channel 23095					
Antenna Polarity & Test Distance: Horizontal at 3 M							
No.	Freq. (MHz)	Reading (dBm)	S.G Power Value (dBm)	Correction Factor (dB)	ERP (dBm)	Limit (dBm)	Margin (dB)
1	707.50	-19.1	5.6	3.5	9.1	34.8	-25.7
Antenna Polarity & Test Distance: Vertical at 3 M							
No.	Freq. (MHz)	Reading (dBm)	S.G Power Value (dBm)	Correction Factor (dB)	EIRP (dBm)	Limit (dBm)	Margin (dB)
1	707.50	-13.6	14.2	3.5	17.7	34.8	-17.1

MODE		TX channel 23155					
Antenna Polarity & Test Distance: Horizontal at 3 M							
No.	Freq. (MHz)	Reading (dBm)	S.G Power Value (dBm)	Correction Factor (dB)	ERP (dBm)	Limit (dBm)	Margin (dB)
1	713.50	-18.9	6.1	3.5	9.6	34.8	-25.2
Antenna Polarity & Test Distance: Vertical at 3 M							
No.	Freq. (MHz)	Reading (dBm)	S.G Power Value (dBm)	Correction Factor (dB)	EIRP (dBm)	Limit (dBm)	Margin (dB)
1	713.50	-13.2	14.5	3.5	18.0	34.8	-16.8

Note: ERP (dBm) = S.G Power Value (dBm) + Correction Factor (dB).

Channel Bandwidth: 10MHz

MODE		TX channel 23060					
Antenna Polarity & Test Distance: Horizontal at 3 M							
No.	Freq. (MHz)	Reading (dBm)	S.G Power Value (dBm)	Correction Factor (dB)	ERP (dBm)	Limit (dBm)	Margin (dB)
1	704.00	-18.6	6.1	3.5	9.6	34.8	-25.2
Antenna Polarity & Test Distance: Vertical at 3 M							
No.	Freq. (MHz)	Reading (dBm)	S.G Power Value (dBm)	Correction Factor (dB)	ERP (dBm)	Limit (dBm)	Margin (dB)
1	704.00	-13.0	14.6	3.5	18.1	34.8	-16.7

MODE		TX channel 23095					
Antenna Polarity & Test Distance: Horizontal at 3 M							
No.	Freq. (MHz)	Reading (dBm)	S.G Power Value (dBm)	Correction Factor (dB)	ERP (dBm)	Limit (dBm)	Margin (dB)
1	707.50	-18.8	6.0	3.5	9.5	34.8	-25.3
Antenna Polarity & Test Distance: Vertical at 3 M							
No.	Freq. (MHz)	Reading (dBm)	S.G Power Value (dBm)	Correction Factor (dB)	ERP (dBm)	Limit (dBm)	Margin (dB)
1	707.50	-13.1	14.7	3.5	18.2	34.8	-16.6

MODE		TX channel 23130					
Antenna Polarity & Test Distance: Horizontal at 3 M							
No.	Freq. (MHz)	Reading (dBm)	S.G Power Value (dBm)	Correction Factor (dB)	ERP (dBm)	Limit (dBm)	Margin (dB)
1	711.00	-19.3	5.7	3.5	9.2	34.8	-25.6
Antenna Polarity & Test Distance: Vertical at 3 M							
No.	Freq. (MHz)	Reading (dBm)	S.G Power Value (dBm)	Correction Factor (dB)	ERP (dBm)	Limit (dBm)	Margin (dB)
1	711.00	-13.5	14.1	3.5	17.6	34.8	-17.2

Note: ERP (dBm) = S.G Power Value (dBm) + Correction Factor (dB).

LTE Band 13

Channel Bandwidth: 5MHz

MODE		TX channel 23205					
Antenna Polarity & Test Distance: Horizontal at 3 M							
No.	Freq. (MHz)	Reading (dBm)	S.G Power Value (dBm)	Correction Factor (dB)	ERP (dBm)	Limit (dBm)	Margin (dB)
1	779.50	-19.2	6.8	4.0	10.8	34.8	-24.0
Antenna Polarity & Test Distance: Vertical at 3 M							
No.	Freq. (MHz)	Reading (dBm)	S.G Power Value (dBm)	Correction Factor (dB)	ERP (dBm)	Limit (dBm)	Margin (dB)
1	779.50	-13.9	14.2	4.0	18.2	34.8	-16.6

MODE		TX channel 23230					
Antenna Polarity & Test Distance: Horizontal at 3 M							
No.	Freq. (MHz)	Reading (dBm)	S.G Power Value (dBm)	Correction Factor (dB)	ERP (dBm)	Limit (dBm)	Margin (dB)
1	782.00	-19.3	6.7	4.0	10.7	34.8	-24.1
Antenna Polarity & Test Distance: Vertical at 3 M							
No.	Freq. (MHz)	Reading (dBm)	S.G Power Value (dBm)	Correction Factor (dB)	ERP (dBm)	Limit (dBm)	Margin (dB)
1	782.00	-14.0	13.9	4.0	17.9	34.8	-16.9

MODE		TX channel 23255					
Antenna Polarity & Test Distance: Horizontal at 3 M							
No.	Freq. (MHz)	Reading (dBm)	S.G Power Value (dBm)	Correction Factor (dB)	ERP (dBm)	Limit (dBm)	Margin (dB)
1	784.50	-18.5	7.6	4.0	11.6	34.8	-23.2
Antenna Polarity & Test Distance: Vertical at 3 M							
No.	Freq. (MHz)	Reading (dBm)	S.G Power Value (dBm)	Correction Factor (dB)	ERP (dBm)	Limit (dBm)	Margin (dB)
1	784.50	-14.1	13.8	4.0	17.8	34.8	-17.0

Note: ERP (dBm) = S.G Power Value (dBm) + Correction Factor (dB).

Channel Bandwidth: 10MHz

MODE		TX channel 23230					
Antenna Polarity & Test Distance: Horizontal at 3 M							
No.	Freq. (MHz)	Reading (dBm)	S.G Power Value (dBm)	Correction Factor (dB)	ERP (dBm)	Limit (dBm)	Margin (dB)
1	782.00	-19.1	6.9	4.0	10.9	34.8	-23.9
Antenna Polarity & Test Distance: Vertical at 3 M							
No.	Freq. (MHz)	Reading (dBm)	S.G Power Value (dBm)	Correction Factor (dB)	ERP (dBm)	Limit (dBm)	Margin (dB)
1	782.00	-14.0	13.9	4.0	17.9	34.8	-16.9

Note: ERP (dBm) = S.G Power Value (dBm) + Correction Factor (dB).

LTE Band 17

Channel Bandwidth: 5MHz

MODE		TX channel 23755					
Antenna Polarity & Test Distance: Horizontal at 3 M							
No.	Freq. (MHz)	Reading (dBm)	S.G Power Value (dBm)	Correction Factor (dB)	ERP (dBm)	Limit (dBm)	Margin (dB)
1	706.50	-18.1	6.6	3.5	10.1	34.8	-24.7
Antenna Polarity & Test Distance: Vertical at 3 M							
No.	Freq. (MHz)	Reading (dBm)	S.G Power Value (dBm)	Correction Factor (dB)	ERP (dBm)	Limit (dBm)	Margin (dB)
1	706.50	-14.0	13.6	3.5	17.1	34.8	-17.7

MODE		TX channel 23790					
Antenna Polarity & Test Distance: Horizontal at 3 M							
No.	Freq. (MHz)	Reading (dBm)	S.G Power Value (dBm)	Correction Factor (dB)	ERP (dBm)	Limit (dBm)	Margin (dB)
1	710.00	-18.4	6.5	3.5	10.0	34.8	-24.8
Antenna Polarity & Test Distance: Vertical at 3 M							
No.	Freq. (MHz)	Reading (dBm)	S.G Power Value (dBm)	Correction Factor (dB)	ERP (dBm)	Limit (dBm)	Margin (dB)
1	710.00	-13.8	13.8	3.5	17.3	34.8	-17.5

MODE		TX channel 23825					
Antenna Polarity & Test Distance: Horizontal at 3 M							
No.	Freq. (MHz)	Reading (dBm)	S.G Power Value (dBm)	Correction Factor (dB)	ERP (dBm)	Limit (dBm)	Margin (dB)
1	713.50	-18.6	6.4	3.5	9.9	34.8	-24.9
Antenna Polarity & Test Distance: Vertical at 3 M							
No.	Freq. (MHz)	Reading (dBm)	S.G Power Value (dBm)	Correction Factor (dB)	ERP (dBm)	Limit (dBm)	Margin (dB)
1	713.50	-14.2	13.5	3.5	17.0	34.8	-17.8

Note: ERP (dBm) = S.G Power Value (dBm) + Correction Factor (dB).

Channel Bandwidth: 10MHz

MODE		TX channel 23780					
Antenna Polarity & Test Distance: Horizontal at 3 M							
No.	Freq. (MHz)	Reading (dBm)	S.G Power Value (dBm)	Correction Factor (dB)	ERP (dBm)	Limit (dBm)	Margin (dB)
1	709.00	-18.1	6.7	3.5	10.2	34.8	-24.6
Antenna Polarity & Test Distance: Vertical at 3 M							
No.	Freq. (MHz)	Reading (dBm)	S.G Power Value (dBm)	Correction Factor (dB)	ERP (dBm)	Limit (dBm)	Margin (dB)
1	709.00	-14.1	13.5	3.5	17.0	34.8	-17.8

MODE		TX channel 23790					
Antenna Polarity & Test Distance: Horizontal at 3 M							
No.	Freq. (MHz)	Reading (dBm)	S.G Power Value (dBm)	Correction Factor (dB)	ERP (dBm)	Limit (dBm)	Margin (dB)
1	710.00	-18.4	6.5	3.5	10.0	34.8	-24.8
Antenna Polarity & Test Distance: Vertical at 3 M							
No.	Freq. (MHz)	Reading (dBm)	S.G Power Value (dBm)	Correction Factor (dB)	ERP (dBm)	Limit (dBm)	Margin (dB)
1	710.00	-14.0	13.6	3.5	17.1	34.8	-17.7

MODE		TX channel 23800					
Antenna Polarity & Test Distance: Horizontal at 3 M							
No.	Freq. (MHz)	Reading (dBm)	S.G Power Value (dBm)	Correction Factor (dB)	ERP (dBm)	Limit (dBm)	Margin (dB)
1	711.00	-18.7	6.3	3.5	9.8	34.8	-25.0
Antenna Polarity & Test Distance: Vertical at 3 M							
No.	Freq. (MHz)	Reading (dBm)	S.G Power Value (dBm)	Correction Factor (dB)	ERP (dBm)	Limit (dBm)	Margin (dB)
1	711.00	-14.3	13.3	3.5	16.8	34.8	-18.0

Note: ERP (dBm) = S.G Power Value (dBm) + Correction Factor (dB).

LTE Band 38

Channel Bandwidth: 5MHz

MODE		TX channel 37775					
Antenna Polarity & Test Distance: Horizontal at 3 M							
No.	Freq. (MHz)	Reading (dBm)	S.G Power Value (dBm)	Correction Factor (dB)	EIRP (dBm)	Limit (dBm)	Margin (dB)
1	2575.50	-18.9	23.1	0.2	23.3	33.0	-9.7
Antenna Polarity & Test Distance: Vertical at 3 M							
No.	Freq. (MHz)	Reading (dBm)	S.G Power Value (dBm)	Correction Factor (dB)	EIRP (dBm)	Limit (dBm)	Margin (dB)
1	2575.50	-26.3	17.4	0.2	17.6	33.0	-15.4

MODE		TX channel 38000					
Antenna Polarity & Test Distance: Horizontal at 3 M							
No.	Freq. (MHz)	Reading (dBm)	S.G Power Value (dBm)	Correction Factor (dB)	EIRP (dBm)	Limit (dBm)	Margin (dB)
1	2595.00	-18.7	23.5	0.2	23.7	33.0	-9.3
Antenna Polarity & Test Distance: Vertical at 3 M							
No.	Freq. (MHz)	Reading (dBm)	S.G Power Value (dBm)	Correction Factor (dB)	EIRP (dBm)	Limit (dBm)	Margin (dB)
1	2595.00	-26.4	17.4	0.2	17.6	33.0	-15.4

MODE		TX channel 38225					
Antenna Polarity & Test Distance: Horizontal at 3 M							
No.	Freq. (MHz)	Reading (dBm)	S.G Power Value (dBm)	Correction Factor (dB)	EIRP (dBm)	Limit (dBm)	Margin (dB)
1	2617.50	-19.4	23.0	0.2	23.2	33.0	-9.8
Antenna Polarity & Test Distance: Vertical at 3 M							
No.	Freq. (MHz)	Reading (dBm)	S.G Power Value (dBm)	Correction Factor (dB)	EIRP (dBm)	Limit (dBm)	Margin (dB)
1	2617.50	-26.9	16.9	0.2	17.1	33.0	-15.9

Note: EIRP (dBm) = S.G Power Value (dBm) + Correction Factor (dB).

Channel Bandwidth: 10MHz

MODE		TX channel 37800					
Antenna Polarity & Test Distance: Horizontal at 3 M							
No.	Freq. (MHz)	Reading (dBm)	S.G Power Value (dBm)	Correction Factor (dB)	EIRP (dBm)	Limit (dBm)	Margin (dB)
1	2575.00	-19.2	22.9	0.2	23.1	33.0	-9.9
Antenna Polarity & Test Distance: Vertical at 3 M							
No.	Freq. (MHz)	Reading (dBm)	S.G Power Value (dBm)	Correction Factor (dB)	EIRP (dBm)	Limit (dBm)	Margin (dB)
1	2575.00	-26.4	17.3	0.2	17.5	33.0	-15.5

MODE		TX channel 38000					
Antenna Polarity & Test Distance: Horizontal at 3 M							
No.	Freq. (MHz)	Reading (dBm)	S.G Power Value (dBm)	Correction Factor (dB)	EIRP (dBm)	Limit (dBm)	Margin (dB)
1	2595.00	-19.6	22.6	0.2	22.8	33.0	-10.2
Antenna Polarity & Test Distance: Vertical at 3 M							
No.	Freq. (MHz)	Reading (dBm)	S.G Power Value (dBm)	Correction Factor (dB)	EIRP (dBm)	Limit (dBm)	Margin (dB)
1	2595.00	-26.7	17.1	0.2	17.3	33.0	-15.7

MODE		TX channel 38200					
Antenna Polarity & Test Distance: Horizontal at 3 M							
No.	Freq. (MHz)	Reading (dBm)	S.G Power Value (dBm)	Correction Factor (dB)	EIRP (dBm)	Limit (dBm)	Margin (dB)
1	2615.00	-19.5	22.9	0.2	23.1	33.0	-9.9
Antenna Polarity & Test Distance: Vertical at 3 M							
No.	Freq. (MHz)	Reading (dBm)	S.G Power Value (dBm)	Correction Factor (dB)	EIRP (dBm)	Limit (dBm)	Margin (dB)
1	2615.00	-26.9	16.9	0.2	17.1	33.0	-15.9

Note: EIRP (dBm) = S.G Power Value (dBm) + Correction Factor (dB).

Channel Bandwidth: 15MHz

MODE		TX channel 37825					
Antenna Polarity & Test Distance: Horizontal at 3 M							
No.	Freq. (MHz)	Reading (dBm)	S.G Power Value (dBm)	Correction Factor (dB)	EIRP (dBm)	Limit (dBm)	Margin (dB)
1	2577.50	-19.1	23.0	0.2	23.2	33.0	-9.8
Antenna Polarity & Test Distance: Vertical at 3 M							
No.	Freq. (MHz)	Reading (dBm)	S.G Power Value (dBm)	Correction Factor (dB)	EIRP (dBm)	Limit (dBm)	Margin (dB)
1	2577.50	-26.4	17.3	0.2	17.5	33.0	-15.5

MODE		TX channel 38000					
Antenna Polarity & Test Distance: Horizontal at 3 M							
No.	Freq. (MHz)	Reading (dBm)	S.G Power Value (dBm)	Correction Factor (dB)	EIRP (dBm)	Limit (dBm)	Margin (dB)
1	2595.00	-19.3	22.9	0.2	23.1	33.0	-9.9
Antenna Polarity & Test Distance: Vertical at 3 M							
No.	Freq. (MHz)	Reading (dBm)	S.G Power Value (dBm)	Correction Factor (dB)	EIRP (dBm)	Limit (dBm)	Margin (dB)
1	2595.00	-26.7	17.1	0.2	17.3	33.0	-15.7

MODE		TX channel 38175					
Antenna Polarity & Test Distance: Horizontal at 3 M							
No.	Freq. (MHz)	Reading (dBm)	S.G Power Value (dBm)	Correction Factor (dB)	EIRP (dBm)	Limit (dBm)	Margin (dB)
1	2612.50	-19.2	23.2	0.2	23.4	33.0	-9.6
Antenna Polarity & Test Distance: Vertical at 3 M							
No.	Freq. (MHz)	Reading (dBm)	S.G Power Value (dBm)	Correction Factor (dB)	EIRP (dBm)	Limit (dBm)	Margin (dB)
1	2612.50	-26.4	17.4	0.2	17.6	33.0	-15.4

Note: EIRP (dBm) = S.G Power Value (dBm) + Correction Factor (dB).

Channel Bandwidth: 20MHz

MODE		TX channel 37850					
Antenna Polarity & Test Distance: Horizontal at 3 M							
No.	Freq. (MHz)	Reading (dBm)	S.G Power Value (dBm)	Correction Factor (dB)	EIRP (dBm)	Limit (dBm)	Margin (dB)
1	2580.00	-19.1	23.1	0.1	23.2	33.0	-9.8
Antenna Polarity & Test Distance: Vertical at 3 M							
No.	Freq. (MHz)	Reading (dBm)	S.G Power Value (dBm)	Correction Factor (dB)	EIRP (dBm)	Limit (dBm)	Margin (dB)
1	2580.00	-27.2	16.6	0.1	16.7	33.0	-16.3

MODE		TX channel 38000					
Antenna Polarity & Test Distance: Horizontal at 3 M							
No.	Freq. (MHz)	Reading (dBm)	S.G Power Value (dBm)	Correction Factor (dB)	EIRP (dBm)	Limit (dBm)	Margin (dB)
1	2595.00	-19.3	22.9	0.2	23.1	33.0	-9.9
Antenna Polarity & Test Distance: Vertical at 3 M							
No.	Freq. (MHz)	Reading (dBm)	S.G Power Value (dBm)	Correction Factor (dB)	EIRP (dBm)	Limit (dBm)	Margin (dB)
1	2595.00	-27.4	16.4	0.2	16.6	33.0	-16.4

MODE		TX channel 38150					
Antenna Polarity & Test Distance: Horizontal at 3 M							
No.	Freq. (MHz)	Reading (dBm)	S.G Power Value (dBm)	Correction Factor (dB)	EIRP (dBm)	Limit (dBm)	Margin (dB)
1	2610.00	-18.9	23.5	0.2	23.7	33.0	-9.3
Antenna Polarity & Test Distance: Vertical at 3 M							
No.	Freq. (MHz)	Reading (dBm)	S.G Power Value (dBm)	Correction Factor (dB)	EIRP (dBm)	Limit (dBm)	Margin (dB)
1	2610.00	-27.6	16.2	0.2	16.4	33.0	-16.6

Note: EIRP (dBm) = S.G Power Value (dBm) + Correction Factor (dB).

LTE Band 41

Channel Bandwidth: 5MHz

MODE		TX channel 40065					
Antenna Polarity & Test Distance: Horizontal at 3 M							
No.	Freq. (MHz)	Reading (dBm)	S.G Power Value (dBm)	Correction Factor (dB)	EIRP (dBm)	Limit (dBm)	Margin (dB)
1	2537.50	-18.9	22.8	0.2	23.0	33.0	-10.0
Antenna Polarity & Test Distance: Vertical at 3 m							
No.	Freq. (MHz)	Reading (dBm)	S.G Power Value (dBm)	Correction Factor (dB)	EIRP (dBm)	Limit (dBm)	Margin (dB)
1	2537.50	-29.7	13.9	0.2	14.1	33.0	-18.9

MODE		TX channel 40640					
Antenna Polarity & Test Distance: Horizontal at 3 M							
No.	Freq. (MHz)	Reading (dBm)	S.G Power Value (dBm)	Correction Factor (dB)	EIRP (dBm)	Limit (dBm)	Margin (dB)
1	2595.00	-19.0	23.2	0.2	23.4	33.0	-9.6
Antenna Polarity & Test Distance: Vertical at 3 m							
No.	Freq. (MHz)	Reading (dBm)	S.G Power Value (dBm)	Correction Factor (dB)	EIRP (dBm)	Limit (dBm)	Margin (dB)
1	2595.00	-30.9	12.9	0.2	13.1	33.0	-19.9

MODE		TX channel 41215					
Antenna Polarity & Test Distance: Horizontal at 3 M							
No.	Freq. (MHz)	Reading (dBm)	S.G Power Value (dBm)	Correction Factor (dB)	EIRP (dBm)	Limit (dBm)	Margin (dB)
1	2652.50	-20.6	22.0	0.3	22.3	33.0	-10.7
Antenna Polarity & Test Distance: Vertical at 3 m							
No.	Freq. (MHz)	Reading (dBm)	S.G Power Value (dBm)	Correction Factor (dB)	EIRP (dBm)	Limit (dBm)	Margin (dB)
1	2652.50	-29.5	14.2	0.3	14.5	33.0	-18.5

Note: ERP (dBm) = S.G Power Value (dBm) + Correction Factor (dB).

Channel Bandwidth: 10MHz

MODE		TX channel 40090					
Antenna Polarity & Test Distance: Horizontal at 3 M							
No.	Freq. (MHz)	Reading (dBm)	S.G Power Value (dBm)	Correction Factor (dB)	EIRP (dBm)	Limit (dBm)	Margin (dB)
1	2540.00	-18.2	23.6	0.2	23.8	33.0	-9.2
Antenna Polarity & Test Distance: Vertical at 3 m							
No.	Freq. (MHz)	Reading (dBm)	S.G Power Value (dBm)	Correction Factor (dB)	EIRP (dBm)	Limit (dBm)	Margin (dB)
1	2540.00	-29.3	14.3	0.2	14.5	33.0	-18.5

MODE		TX channel 40640					
Antenna Polarity & Test Distance: Horizontal at 3 M							
No.	Freq. (MHz)	Reading (dBm)	S.G Power Value (dBm)	Correction Factor (dB)	EIRP (dBm)	Limit (dBm)	Margin (dB)
1	2595.00	-19.7	22.5	0.2	22.7	33.0	-10.3
Antenna Polarity & Test Distance: Vertical at 3 m							
No.	Freq. (MHz)	Reading (dBm)	S.G Power Value (dBm)	Correction Factor (dB)	EIRP (dBm)	Limit (dBm)	Margin (dB)
1	2595.00	-30.3	13.5	0.2	13.7	33.0	-19.3

MODE		TX channel 41190					
Antenna Polarity & Test Distance: Horizontal at 3 M							
No.	Freq. (MHz)	Reading (dBm)	S.G Power Value (dBm)	Correction Factor (dB)	EIRP (dBm)	Limit (dBm)	Margin (dB)
1	2650.00	-19.4	23.2	0.3	23.5	33.0	-9.5
Antenna Polarity & Test Distance: Vertical at 3 m							
No.	Freq. (MHz)	Reading (dBm)	S.G Power Value (dBm)	Correction Factor (dB)	EIRP (dBm)	Limit (dBm)	Margin (dB)
1	2650.00	-29.8	13.9	0.3	14.2	33.0	-18.8

Note: ERP (dBm) = S.G Power Value (dBm) + Correction Factor (dB).

Channel Bandwidth: 15MHz

MODE		TX channel 40115					
Antenna Polarity & Test Distance: Horizontal at 3 M							
No.	Freq. (MHz)	Reading (dBm)	S.G Power Value (dBm)	Correction Factor (dB)	EIRP (dBm)	Limit (dBm)	Margin (dB)
1	2542.50	-19.5	22.3	0.2	22.5	33.0	-10.5
Antenna Polarity & Test Distance: Vertical at 3 m							
No.	Freq. (MHz)	Reading (dBm)	S.G Power Value (dBm)	Correction Factor (dB)	EIRP (dBm)	Limit (dBm)	Margin (dB)
1	2542.50	-29.2	14.4	0.2	14.6	33.0	-18.4

MODE		TX channel 40640					
Antenna Polarity & Test Distance: Horizontal at 3 M							
No.	Freq. (MHz)	Reading (dBm)	S.G Power Value (dBm)	Correction Factor (dB)	EIRP (dBm)	Limit (dBm)	Margin (dB)
1	2595.00	-19.7	22.5	0.2	22.7	33.0	-10.3
Antenna Polarity & Test Distance: Vertical at 3 m							
No.	Freq. (MHz)	Reading (dBm)	S.G Power Value (dBm)	Correction Factor (dB)	EIRP (dBm)	Limit (dBm)	Margin (dB)
1	2595.00	-29.4	14.4	0.2	14.6	33.0	-18.4

MODE		TX channel 41165					
Antenna Polarity & Test Distance: Horizontal at 3 M							
No.	Freq. (MHz)	Reading (dBm)	S.G Power Value (dBm)	Correction Factor (dB)	EIRP (dBm)	Limit (dBm)	Margin (dB)
1	2647.50	-20.5	22.1	0.3	22.4	33.0	-10.6
Antenna Polarity & Test Distance: Vertical at 3 m							
No.	Freq. (MHz)	Reading (dBm)	S.G Power Value (dBm)	Correction Factor (dB)	EIRP (dBm)	Limit (dBm)	Margin (dB)
1	2647.50	-29.6	14.1	0.3	14.4	33.0	-18.6

Note: ERP (dBm) = S.G Power Value (dBm) + Correction Factor (dB).

Channel Bandwidth: 20MHz

MODE		TX channel 40140					
Antenna Polarity & Test Distance: Horizontal at 3 M							
No.	Freq. (MHz)	Reading (dBm)	S.G Power Value (dBm)	Correction Factor (dB)	EIRP (dBm)	Limit (dBm)	Margin (dB)
1	2545.00	-19.6	22.2	0.2	22.4	33.0	-10.6
Antenna Polarity & Test Distance: Vertical at 3 m							
No.	Freq. (MHz)	Reading (dBm)	S.G Power Value (dBm)	Correction Factor (dB)	EIRP (dBm)	Limit (dBm)	Margin (dB)
1	2545.00	-29.5	14.1	0.2	14.3	33.0	-18.7

MODE		TX channel 40640					
Antenna Polarity & Test Distance: Horizontal at 3 M							
No.	Freq. (MHz)	Reading (dBm)	S.G Power Value (dBm)	Correction Factor (dB)	EIRP (dBm)	Limit (dBm)	Margin (dB)
1	2595.00	-19.4	22.8	0.2	23.0	33.0	-10.0
Antenna Polarity & Test Distance: Vertical at 3 m							
No.	Freq. (MHz)	Reading (dBm)	S.G Power Value (dBm)	Correction Factor (dB)	EIRP (dBm)	Limit (dBm)	Margin (dB)
1	2595.00	-30.1	13.7	0.2	13.9	33.0	-19.1

MODE		TX channel 41140					
Antenna Polarity & Test Distance: Horizontal at 3 M							
No.	Freq. (MHz)	Reading (dBm)	S.G Power Value (dBm)	Correction Factor (dB)	EIRP (dBm)	Limit (dBm)	Margin (dB)
1	2645.00	-20.0	22.6	0.3	22.9	33.0	-10.1
Antenna Polarity & Test Distance: Vertical at 3 m							
No.	Freq. (MHz)	Reading (dBm)	S.G Power Value (dBm)	Correction Factor (dB)	EIRP (dBm)	Limit (dBm)	Margin (dB)
1	2645.00	-29.8	13.9	0.3	14.2	33.0	-18.8

Note: ERP (dBm) = S.G Power Value (dBm) + Correction Factor (dB).

LTE Band 66

Channel Bandwidth: 1.4MHz

MODE		TX channel 131979					
Antenna Polarity & Test Distance: Horizontal at 3 M							
No.	Freq. (MHz)	Reading (dBm)	S.G Power Value (dBm)	Correction Factor (dB)	EIRP (dBm)	Limit (dBm)	Margin (dB)
1	1710.70	-13.2	24.8	0.7	25.5	30.0	-4.5
Antenna Polarity & Test Distance: Vertical at 3 M							
No.	Freq. (MHz)	Reading (dBm)	S.G Power Value (dBm)	Correction Factor (dB)	EIRP (dBm)	Limit (dBm)	Margin (dB)
1	1710.70	-21.5	16.3	0.7	17.0	30.0	-13.0

MODE		TX channel 132322					
Antenna Polarity & Test Distance: Horizontal at 3 M							
No.	Freq. (MHz)	Reading (dBm)	S.G Power Value (dBm)	Correction Factor (dB)	EIRP (dBm)	Limit (dBm)	Margin (dB)
1	1745.00	-12.8	25.9	0.5	26.4	30.0	-3.6
Antenna Polarity & Test Distance: Vertical at 3 M							
No.	Freq. (MHz)	Reading (dBm)	S.G Power Value (dBm)	Correction Factor (dB)	EIRP (dBm)	Limit (dBm)	Margin (dB)
1	1745.00	-21.4	17.3	0.5	17.8	30.0	-12.2

MODE		TX channel 132665					
Antenna Polarity & Test Distance: Horizontal at 3 M							
No.	Freq. (MHz)	Reading (dBm)	S.G Power Value (dBm)	Correction Factor (dB)	EIRP (dBm)	Limit (dBm)	Margin (dB)
1	1779.30	-11.6	27.6	0.4	28.0	30.0	-2.0
Antenna Polarity & Test Distance: Vertical at 3 M							
No.	Freq. (MHz)	Reading (dBm)	S.G Power Value (dBm)	Correction Factor (dB)	EIRP (dBm)	Limit (dBm)	Margin (dB)
1	1779.30	-20.4	19.1	0.4	19.5	30.0	-10.5

Note: EIRP (dBm) = S.G Power Value (dBm) + Correction Factor (dB).

Channel Bandwidth: 3MHz

MODE		TX channel 131987					
Antenna Polarity & Test Distance: Horizontal at 3 M							
No.	Freq. (MHz)	Reading (dBm)	S.G Power Value (dBm)	Correction Factor (dB)	EIRP (dBm)	Limit (dBm)	Margin (dB)
1	1711.50	-12.6	25.4	0.7	26.1	30.0	-3.9
Antenna Polarity & Test Distance: Vertical at 3 M							
No.	Freq. (MHz)	Reading (dBm)	S.G Power Value (dBm)	Correction Factor (dB)	EIRP (dBm)	Limit (dBm)	Margin (dB)
1	1711.50	-21.0	16.8	0.7	17.5	30.0	-12.5

MODE		TX channel 132322					
Antenna Polarity & Test Distance: Horizontal at 3 M							
No.	Freq. (MHz)	Reading (dBm)	S.G Power Value (dBm)	Correction Factor (dB)	EIRP (dBm)	Limit (dBm)	Margin (dB)
1	1745.00	-12.5	26.2	0.5	26.7	30.0	-3.3
Antenna Polarity & Test Distance: Vertical at 3 M							
No.	Freq. (MHz)	Reading (dBm)	S.G Power Value (dBm)	Correction Factor (dB)	EIRP (dBm)	Limit (dBm)	Margin (dB)
1	1745.00	-20.8	17.9	0.5	18.4	30.0	-11.6

MODE		TX channel 132657					
Antenna Polarity & Test Distance: Horizontal at 3 M							
No.	Freq. (MHz)	Reading (dBm)	S.G Power Value (dBm)	Correction Factor (dB)	EIRP (dBm)	Limit (dBm)	Margin (dB)
1	1778.50	-11.3	27.9	0.4	28.3	30.0	-1.7
Antenna Polarity & Test Distance: Vertical at 3 M							
No.	Freq. (MHz)	Reading (dBm)	S.G Power Value (dBm)	Correction Factor (dB)	EIRP (dBm)	Limit (dBm)	Margin (dB)
1	1778.50	-19.7	19.8	0.4	20.2	30.0	-9.8

Note: EIRP (dBm) = S.G Power Value (dBm) + Correction Factor (dB).

Channel Bandwidth: 5MHz

MODE		TX channel 131997					
Antenna Polarity & Test Distance: Horizontal at 3 M							
No.	Freq. (MHz)	Reading (dBm)	S.G Power Value (dBm)	Correction Factor (dB)	EIRP (dBm)	Limit (dBm)	Margin (dB)
1	1712.50	-12.7	25.4	0.7	26.1	30.0	-3.9
Antenna Polarity & Test Distance: Vertical at 3 M							
No.	Freq. (MHz)	Reading (dBm)	S.G Power Value (dBm)	Correction Factor (dB)	EIRP (dBm)	Limit (dBm)	Margin (dB)
1	1712.50	-20.9	17.0	0.7	17.7	30.0	-12.3

MODE		TX channel 132322					
Antenna Polarity & Test Distance: Horizontal at 3 M							
No.	Freq. (MHz)	Reading (dBm)	S.G Power Value (dBm)	Correction Factor (dB)	EIRP (dBm)	Limit (dBm)	Margin (dB)
1	1745.00	-12.8	25.9	0.5	26.4	30.0	-3.6
Antenna Polarity & Test Distance: Vertical at 3 M							
No.	Freq. (MHz)	Reading (dBm)	S.G Power Value (dBm)	Correction Factor (dB)	EIRP (dBm)	Limit (dBm)	Margin (dB)
1	1745.00	-21.5	17.2	0.5	17.7	30.0	-12.3

MODE		TX channel 132647					
Antenna Polarity & Test Distance: Horizontal at 3 M							
No.	Freq. (MHz)	Reading (dBm)	S.G Power Value (dBm)	Correction Factor (dB)	EIRP (dBm)	Limit (dBm)	Margin (dB)
1	1777.50	-11.4	27.8	0.4	28.2	30.0	-1.8
Antenna Polarity & Test Distance: Vertical at 3 M							
No.	Freq. (MHz)	Reading (dBm)	S.G Power Value (dBm)	Correction Factor (dB)	EIRP (dBm)	Limit (dBm)	Margin (dB)
1	1777.50	-19.8	19.6	0.4	20.0	30.0	-10.0

Note: EIRP (dBm) = S.G Power Value (dBm) + Correction Factor (dB).

Channel Bandwidth: 10MHz

MODE		TX channel 132022					
Antenna Polarity & Test Distance: Horizontal at 3 M							
No.	Freq. (MHz)	Reading (dBm)	S.G Power Value (dBm)	Correction Factor (dB)	EIRP (dBm)	Limit (dBm)	Margin (dB)
1	1715.00	-12.6	25.5	0.7	26.2	30.0	-3.8
Antenna Polarity & Test Distance: Vertical at 3 M							
No.	Freq. (MHz)	Reading (dBm)	S.G Power Value (dBm)	Correction Factor (dB)	EIRP (dBm)	Limit (dBm)	Margin (dB)
1	1715.00	-21.0	16.9	0.7	17.6	30.0	-12.4

MODE		TX channel 132322					
Antenna Polarity & Test Distance: Horizontal at 3 M							
No.	Freq. (MHz)	Reading (dBm)	S.G Power Value (dBm)	Correction Factor (dB)	EIRP (dBm)	Limit (dBm)	Margin (dB)
1	1745.00	-12.8	25.9	0.5	26.4	30.0	-3.6
Antenna Polarity & Test Distance: Vertical at 3 M							
No.	Freq. (MHz)	Reading (dBm)	S.G Power Value (dBm)	Correction Factor (dB)	EIRP (dBm)	Limit (dBm)	Margin (dB)
1	1745.00	-21.1	17.6	0.5	18.1	30.0	-11.9

MODE		TX channel 132622					
Antenna Polarity & Test Distance: Horizontal at 3 M							
No.	Freq. (MHz)	Reading (dBm)	S.G Power Value (dBm)	Correction Factor (dB)	EIRP (dBm)	Limit (dBm)	Margin (dB)
1	1775.00	-11.4	27.8	0.4	28.2	30.0	-1.8
Antenna Polarity & Test Distance: Vertical at 3 M							
No.	Freq. (MHz)	Reading (dBm)	S.G Power Value (dBm)	Correction Factor (dB)	EIRP (dBm)	Limit (dBm)	Margin (dB)
1	1775.00	-20.2	19.2	0.4	19.6	30.0	-10.4

Note: EIRP (dBm) = S.G Power Value (dBm) + Correction Factor (dB).

Channel Bandwidth: 15MHz

MODE		TX channel 132047					
Antenna Polarity & Test Distance: Horizontal at 3 M							
No.	Freq. (MHz)	Reading (dBm)	S.G Power Value (dBm)	Correction Factor (dB)	EIRP (dBm)	Limit (dBm)	Margin (dB)
1	1717.50	-12.7	25.4	0.7	26.1	30.0	-3.9
Antenna Polarity & Test Distance: Vertical at 3 M							
No.	Freq. (MHz)	Reading (dBm)	S.G Power Value (dBm)	Correction Factor (dB)	EIRP (dBm)	Limit (dBm)	Margin (dB)
1	1717.50	-21.2	16.8	0.7	17.5	30.0	-12.5

MODE		TX channel 132322					
Antenna Polarity & Test Distance: Horizontal at 3 M							
No.	Freq. (MHz)	Reading (dBm)	S.G Power Value (dBm)	Correction Factor (dB)	EIRP (dBm)	Limit (dBm)	Margin (dB)
1	1745.00	-12.7	26.0	0.5	26.5	30.0	-3.5
Antenna Polarity & Test Distance: Vertical at 3 M							
No.	Freq. (MHz)	Reading (dBm)	S.G Power Value (dBm)	Correction Factor (dB)	EIRP (dBm)	Limit (dBm)	Margin (dB)
1	1745.00	-20.8	17.9	0.5	18.4	30.0	-11.6

MODE		TX channel 132597					
Antenna Polarity & Test Distance: Horizontal at 3 M							
No.	Freq. (MHz)	Reading (dBm)	S.G Power Value (dBm)	Correction Factor (dB)	EIRP (dBm)	Limit (dBm)	Margin (dB)
1	1772.50	-11.4	27.8	0.4	28.2	30.0	-1.8
Antenna Polarity & Test Distance: Vertical at 3 M							
No.	Freq. (MHz)	Reading (dBm)	S.G Power Value (dBm)	Correction Factor (dB)	EIRP (dBm)	Limit (dBm)	Margin (dB)
1	1772.50	-19.7	19.6	0.4	20.0	30.0	-10.0

Note: EIRP (dBm) = S.G Power Value (dBm) + Correction Factor (dB).

Channel Bandwidth: 20MHz

MODE		TX channel 132072					
Antenna Polarity & Test Distance: Horizontal at 3 M							
No.	Freq. (MHz)	Reading (dBm)	S.G Power Value (dBm)	Correction Factor (dB)	EIRP (dBm)	Limit (dBm)	Margin (dB)
1	1720.00	-12.8	25.4	0.7	26.1	30.0	-3.9
Antenna Polarity & Test Distance: Vertical at 3 M							
No.	Freq. (MHz)	Reading (dBm)	S.G Power Value (dBm)	Correction Factor (dB)	EIRP (dBm)	Limit (dBm)	Margin (dB)
1	1720.00	-20.9	17.1	0.7	17.8	30.0	-12.2

MODE		TX channel 132322					
Antenna Polarity & Test Distance: Horizontal at 3 M							
No.	Freq. (MHz)	Reading (dBm)	S.G Power Value (dBm)	Correction Factor (dB)	EIRP (dBm)	Limit (dBm)	Margin (dB)
1	1745.00	-13.0	25.7	0.5	26.2	30.0	-3.8
Antenna Polarity & Test Distance: Vertical at 3 M							
No.	Freq. (MHz)	Reading (dBm)	S.G Power Value (dBm)	Correction Factor (dB)	EIRP (dBm)	Limit (dBm)	Margin (dB)
1	1745.00	-21.5	17.2	0.5	17.7	30.0	-12.3

MODE		TX channel 132572					
Antenna Polarity & Test Distance: Horizontal at 3 M							
No.	Freq. (MHz)	Reading (dBm)	S.G Power Value (dBm)	Correction Factor (dB)	EIRP (dBm)	Limit (dBm)	Margin (dB)
1	1770.00	-11.9	27.1	0.5	27.6	30.0	-2.4
Antenna Polarity & Test Distance: Vertical at 3 M							
No.	Freq. (MHz)	Reading (dBm)	S.G Power Value (dBm)	Correction Factor (dB)	EIRP (dBm)	Limit (dBm)	Margin (dB)
1	1770.00	-19.9	19.3	0.5	19.8	30.0	-10.2

Note: EIRP (dBm) = S.G Power Value (dBm) + Correction Factor (dB).

4.2 Modulation Characteristics Measurement

4.2.1 Limits of Modulation Characteristics

N/A

4.2.2 Test Procedure

Connect the EUT to Communication Simulator via the antenna connector, the frequency band is set as EUT supported Modulation and Channels, the EUT output is matched with 50 ohm load, the waveform quality and constellation of the EUT was tested.

4.2.3 Test Setup

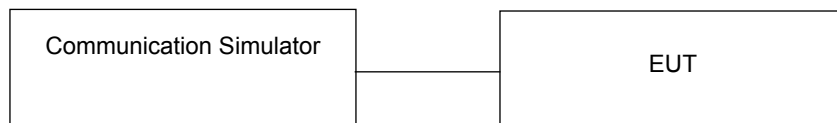

4.2.4 Test Results

Spectrum Plot of Measurement Value

Channel: 1413 / Frequency (MHz): 1732.6MHz

WCDMA

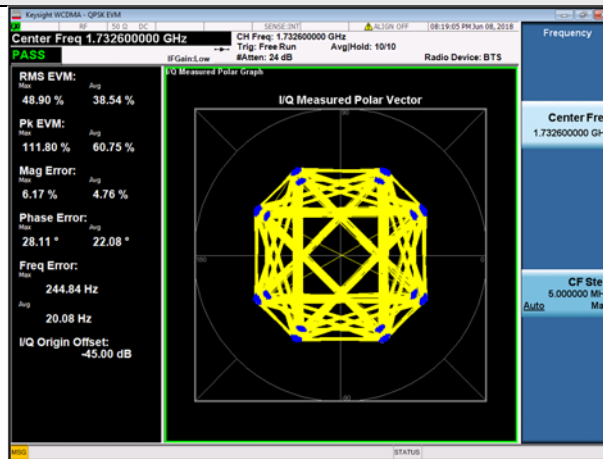

LTE Band 4

Spectrum Plot of Measurement Value

Channel: 20175 / Frequency (MHz): 1732.5MHz

Channel Bandwidth: 1.4MHz / QPSK

Channel Bandwidth: 1.4MHz / 16QAM

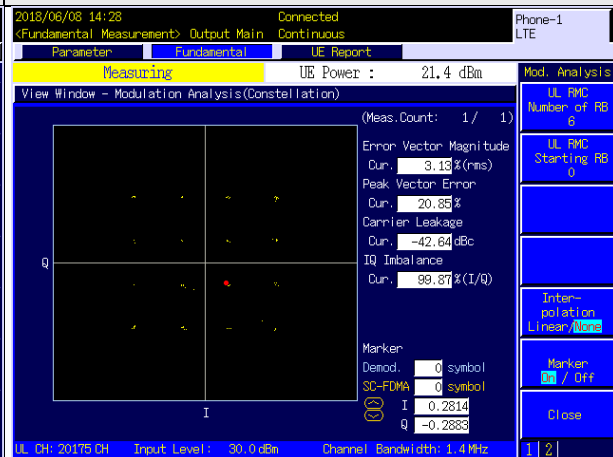
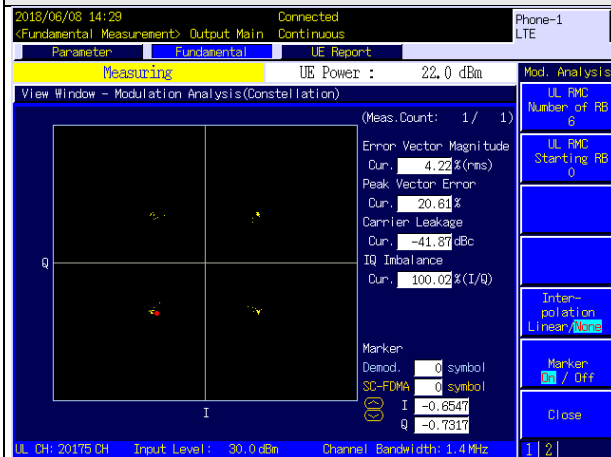

Channel Bandwidth: 20MHz / QPSK

Channel Bandwidth: 20MHz / 16QAM

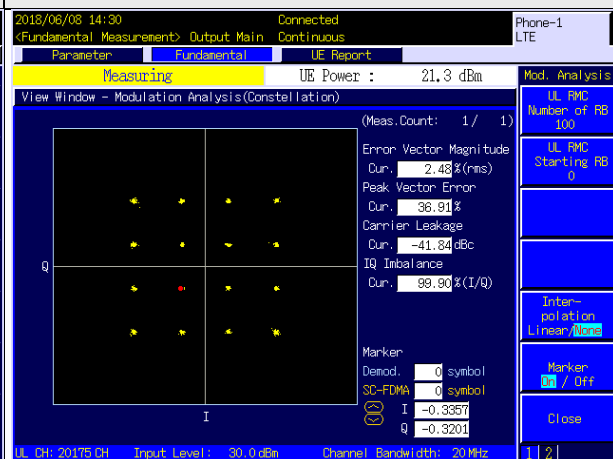
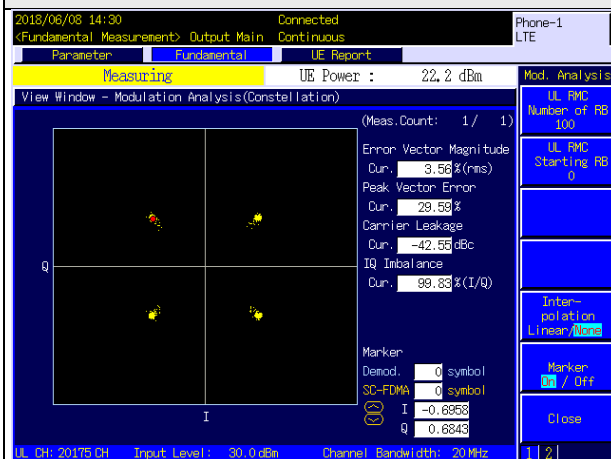

LTE Band 7

Spectrum Plot of Measurement Value

Channel: 21100 / Frequency (MHz): 2535 MHz

Channel Bandwidth: 5MHz / QPSK

Channel Bandwidth: 5MHz / 16QAM

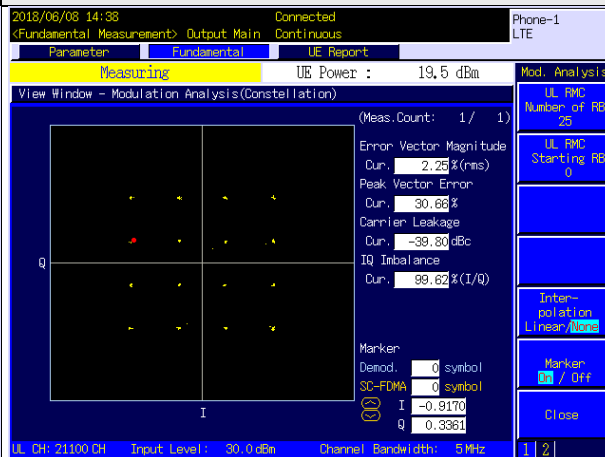
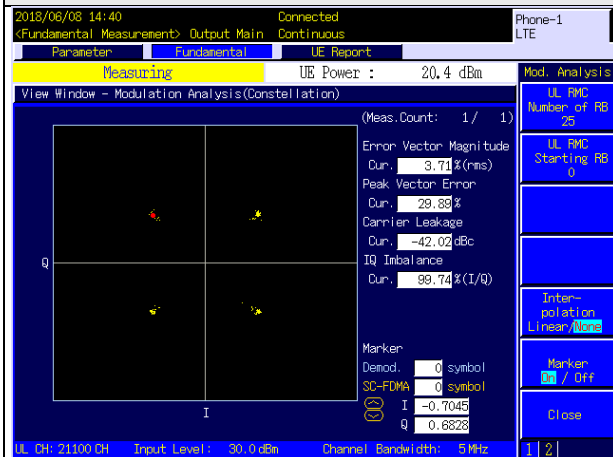

Channel Bandwidth: 20MHz / QPSK

Channel Bandwidth: 20MHz / 16QAM

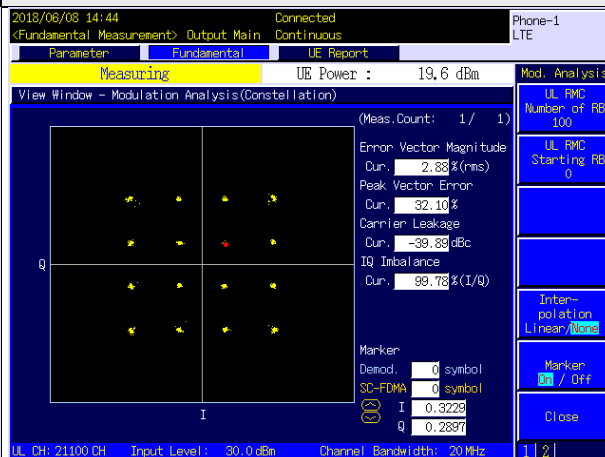
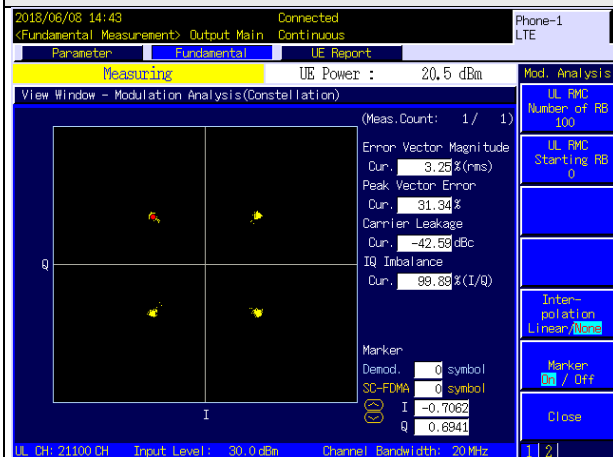

LTE Band 12

Spectrum Plot of Measurement Value

Channel: 23095 / Frequency (MHz): 707.5 MHz

Channel Bandwidth: 1.4MHz / QPSK

Channel Bandwidth: 1.4MHz / 16QAM

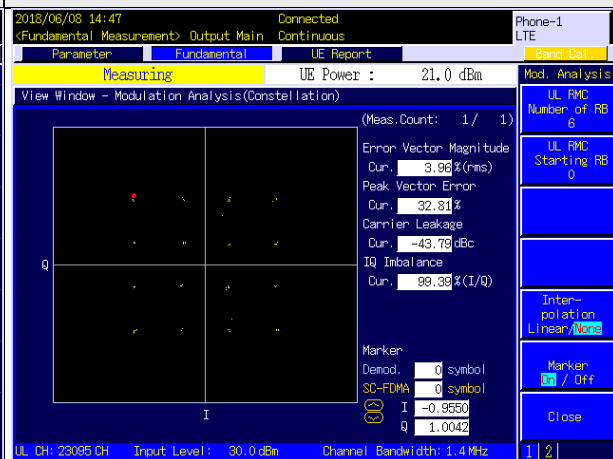
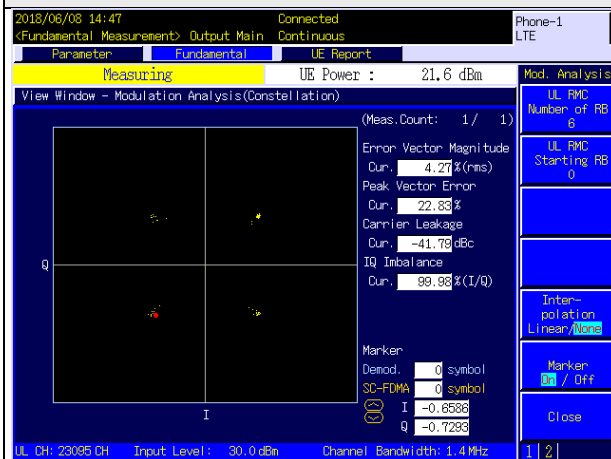

Channel Bandwidth: 10MHz / QPSK

Channel Bandwidth: 10MHz / 16QAM

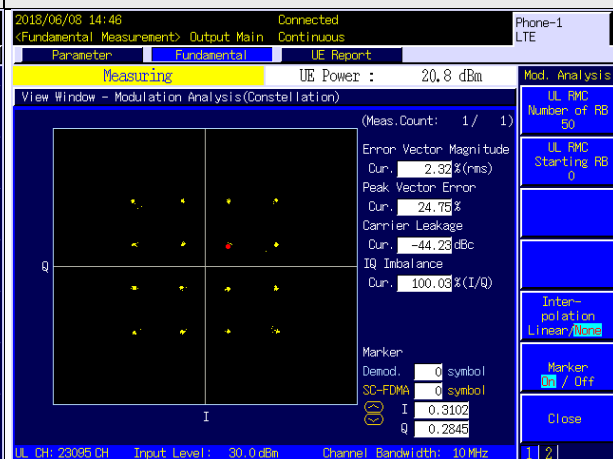
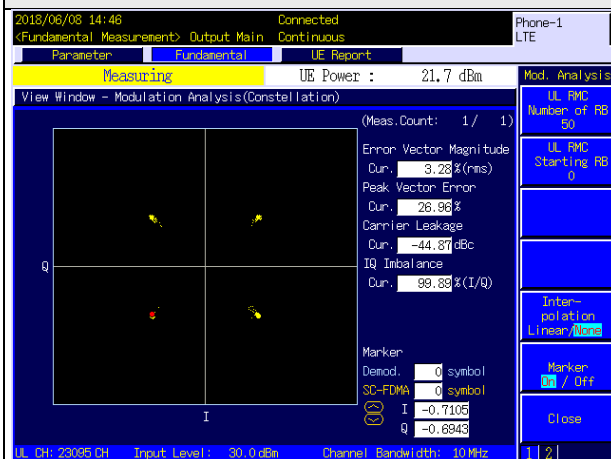

LTE Band 13

Spectrum Plot of Measurement Value

Channel: 23230 / Frequency (MHz): 782.0MHz

Channel Bandwidth: 5MHz / QPSK

Channel Bandwidth: 5MHz / 16QAM

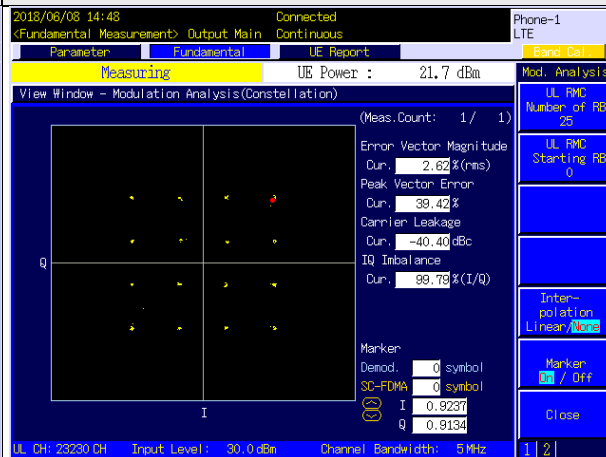
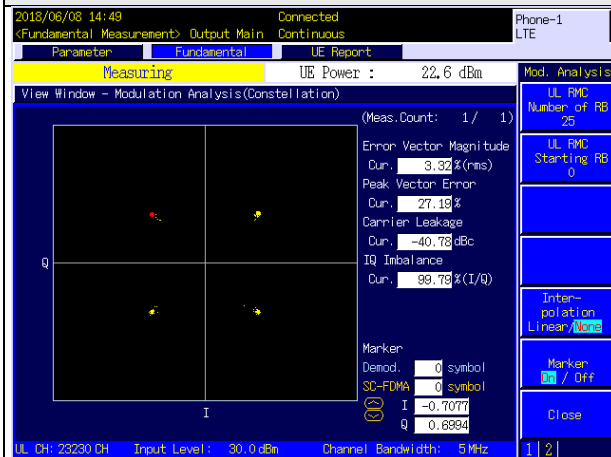

Channel Bandwidth: 10MHz / QPSK

Channel Bandwidth: 10MHz / 16QAM

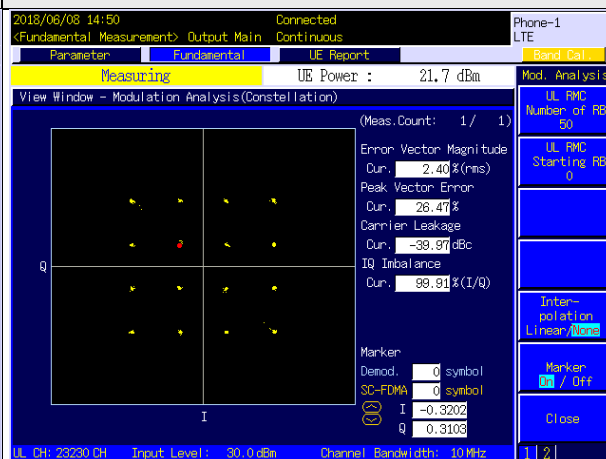
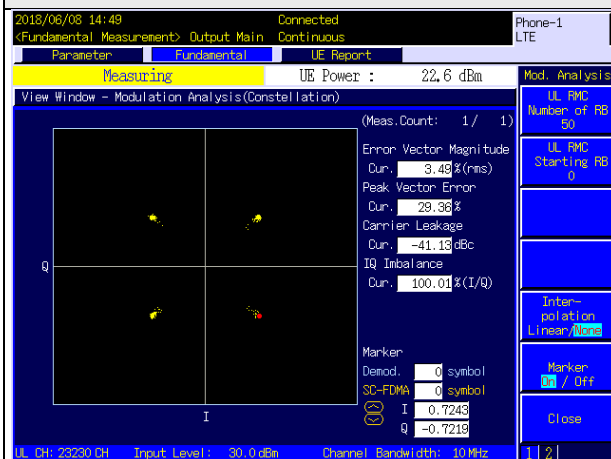

LTE Band 17

Spectrum Plot of Measurement Value

Channel: 23790 / Frequency (MHz): 710.0MHz

Channel Bandwidth: 5MHz / QPSK

Channel Bandwidth: 5MHz / 16QAM

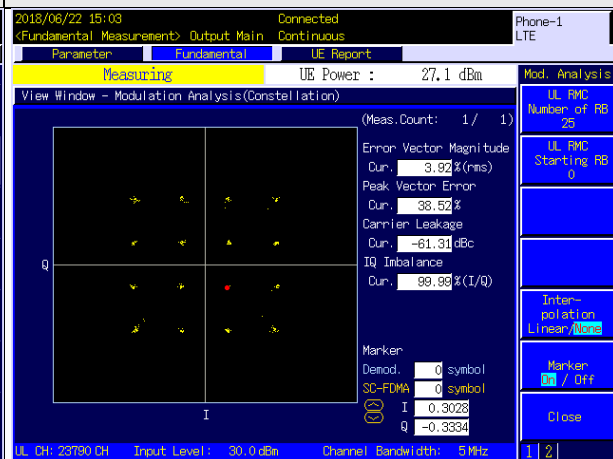
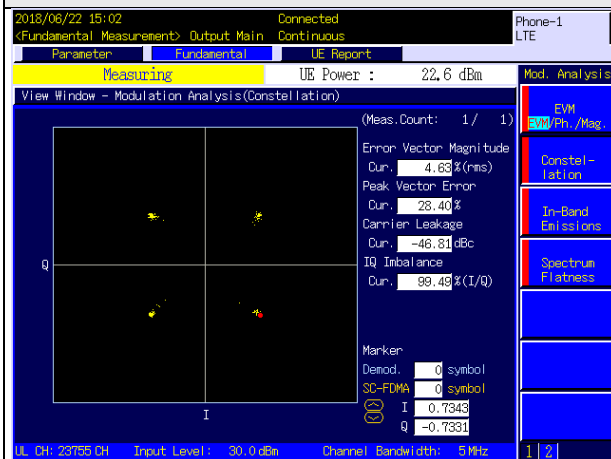

Channel Bandwidth: 10MHz / QPSK

Channel Bandwidth: 10MHz / 16QAM

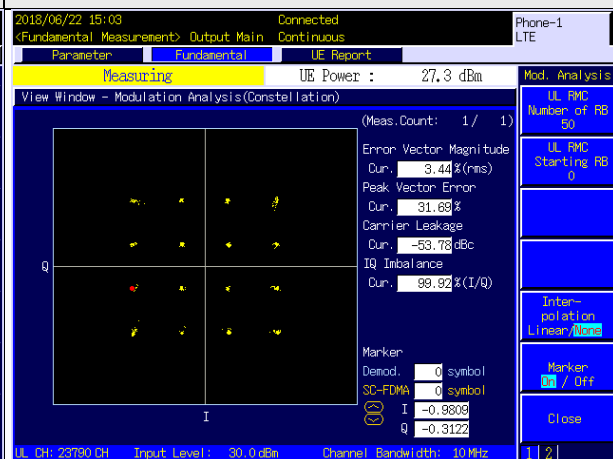
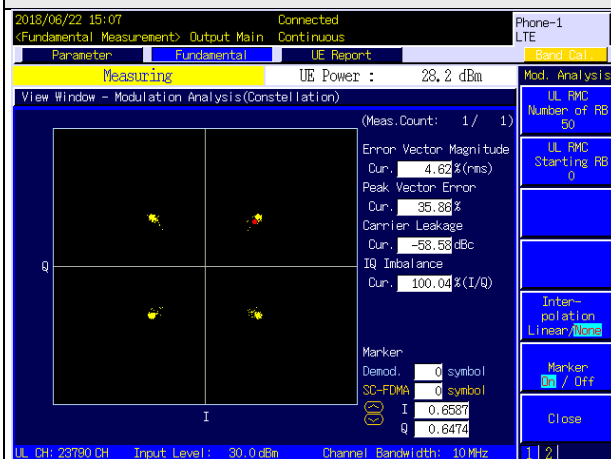

LTE Band 38

Spectrum Plot of Measurement Value

Channel: 38000 / Frequency (MHz): 2595.0 MHz

Channel Bandwidth: 5MHz / QPSK

Channel Bandwidth: 5MHz / 16QAM

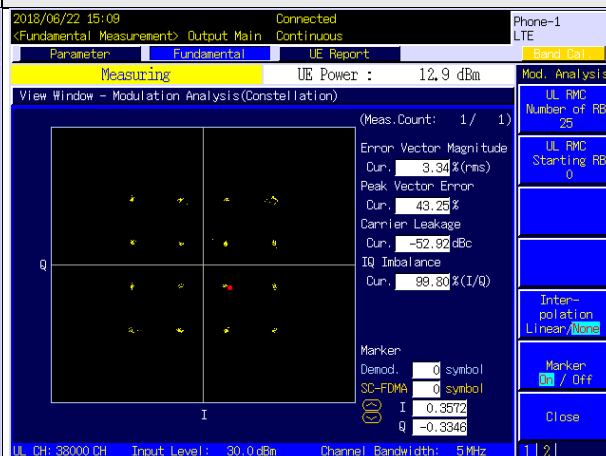
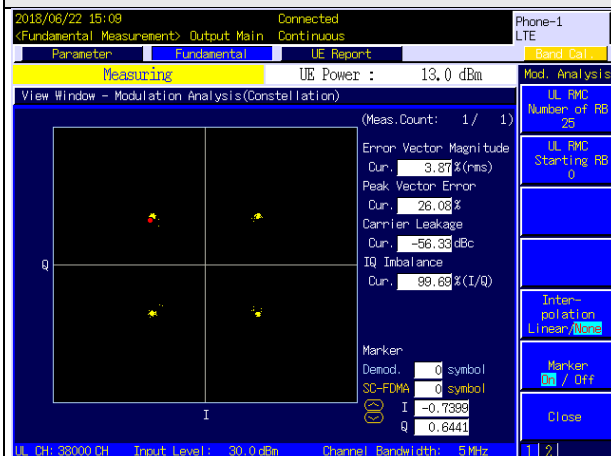

Channel Bandwidth: 20MHz / QPSK

Channel Bandwidth: 20MHz / 16QAM

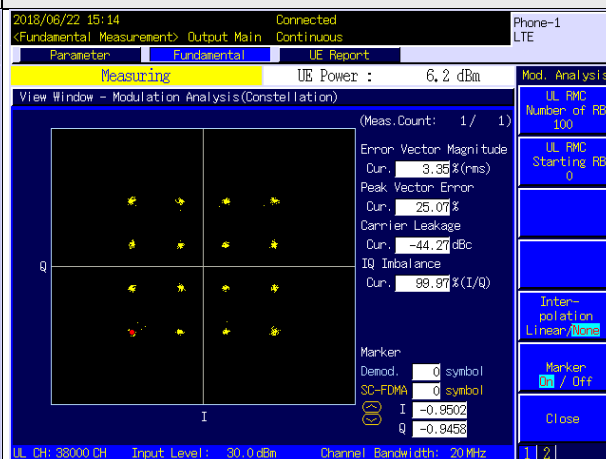
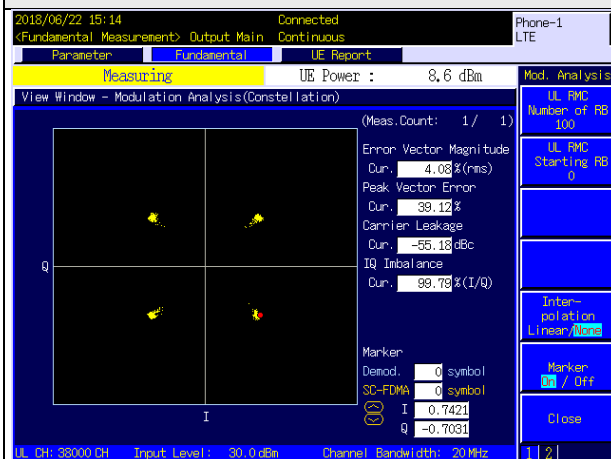

LTE Band 41

Spectrum Plot of Measurement Value

Channel: 40640 / Frequency (MHz): 2595.0 MHz

Channel Bandwidth: 20MHz / QPSK

Channel Bandwidth: 20MHz / 16QAM

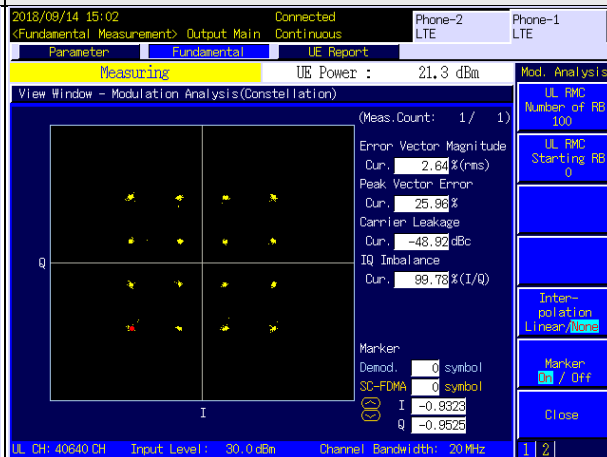
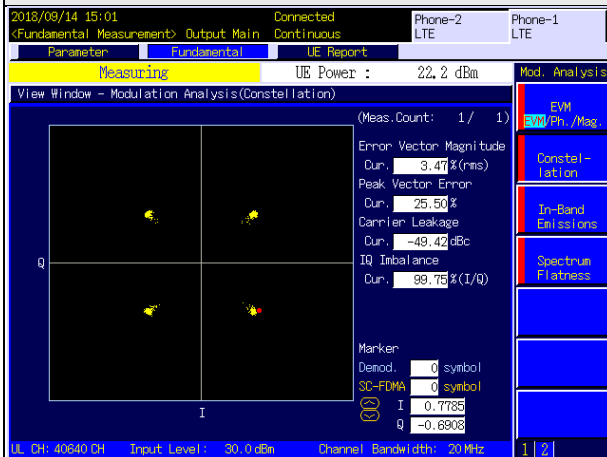

Channel Bandwidth: 20MHz / 64QAM

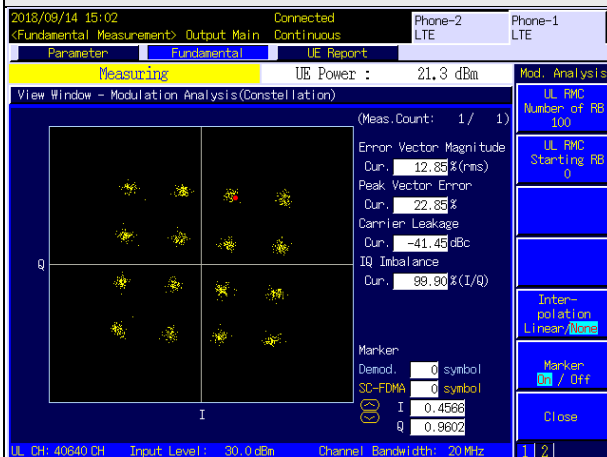

LTE Band 66

Spectrum Plot of Measurement Value

Channel: 132322 / Frequency (MHz): 1745 MHz

Channel Bandwidth: 1.4MHz / QPSK

Channel Bandwidth: 1.4MHz / 16QAM

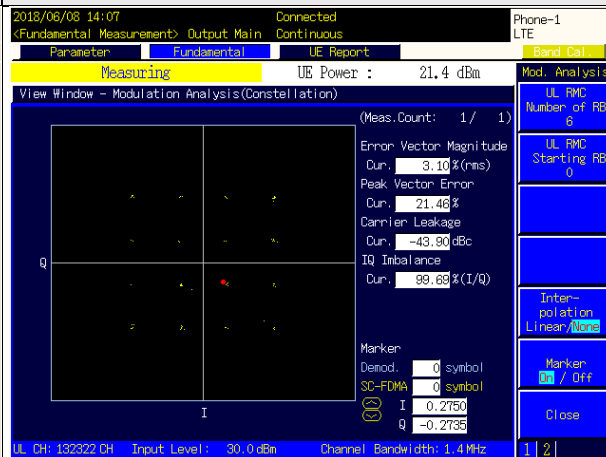
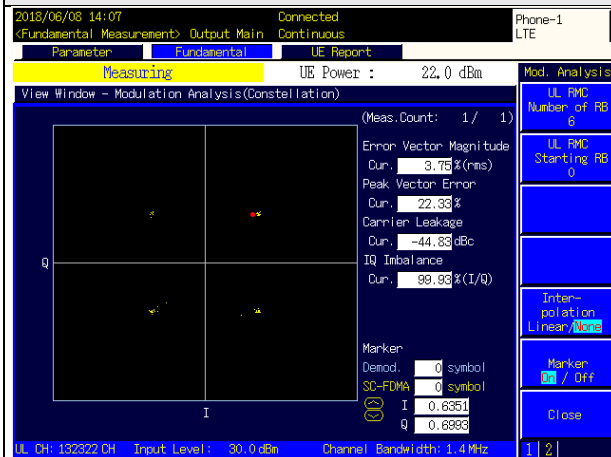

Channel Bandwidth: 20MHz / QPSK

Channel Bandwidth: 20MHz / 16QAM

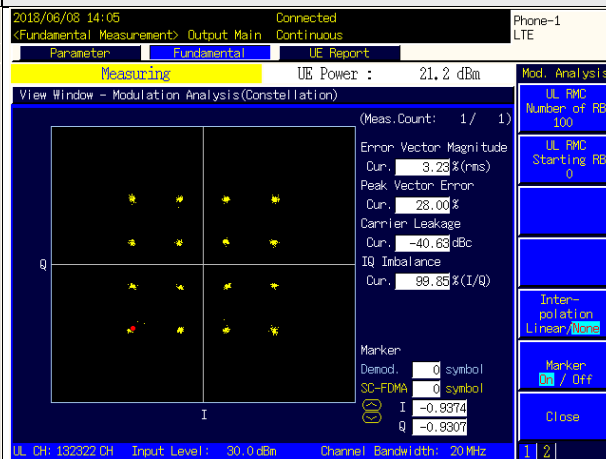
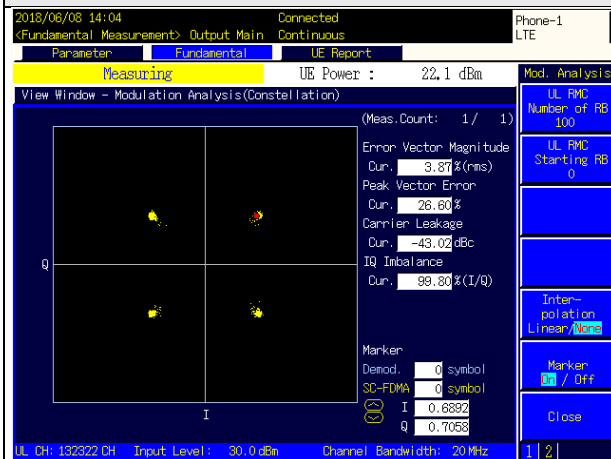

4.3 Frequency Stability Measurement

4.3.1 Limits of Frequency Stability Measurement

According to the FCC part 2.1055 shall be tested the frequency stability. The rule is defined that "The frequency stability shall be sufficient to ensure that the fundamental emission stays within the authorized frequency block." The test extreme voltage is according to the 2.1055(d)(1) Vary primary supply voltage from 85 to 115 percent of the nominal value for other than hand carried battery equipment and the extreme temperature rule is comply with specification of EUT $-30^{\circ}\text{C} \sim 50^{\circ}\text{C}$.

4.3.2 Test Procedure

- Device is placed at the oven room. The oven room could control the temperatures and humidity. Power warm up is at least 15 min and power applied should perform before recording frequency error.
- EUT is connected the external power supply to control the DC input power. The test voltage range is from minimum to maximum working voltage. Each step shall be record the frequency error rate.
- The temperature range step is 10 degrees in this test items. All temperature levels shall be hold the $\pm 0.5^{\circ}\text{C}$ during the measurement testing. The each temperature step shall be at least 0.5 hours, consider the EUT could be test under the stability condition.

Note: The frequency error was recorded frequency error from the communication simulator.

4.3.3 Test Setup

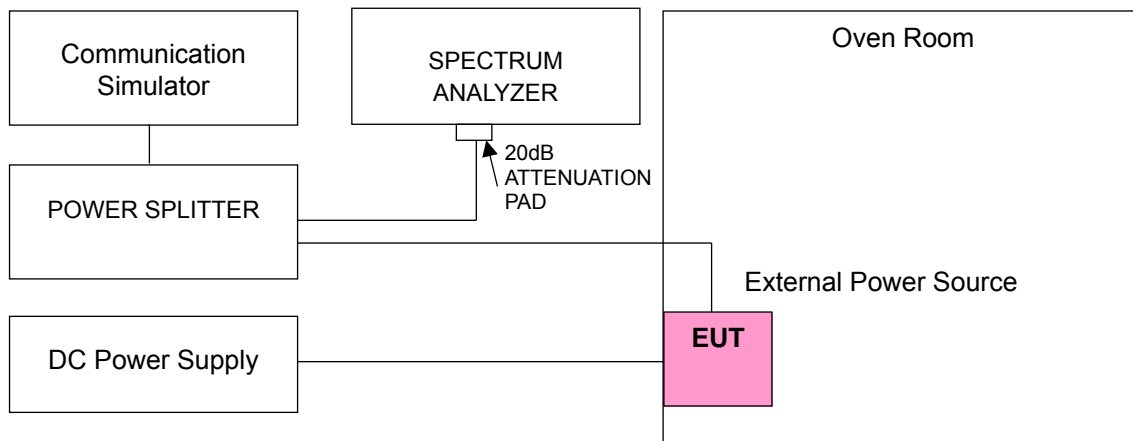

4.3.4 Test Results

Frequency Error vs. Voltage

Voltage (Volts)	Frequency Error (ppm)					Limit (ppm)
	WCDMA Band 4	LTE Band 4	LTE Band 7	LTE Band 12	LTE Band 13	
4.3	0.05453	0.06932	0.07910	0.04714	0.05391	2.5
3.8	0.05236	0.01617	0.13322	0.03761	0.02806	2.5
3.6	0.06853	0.06472	0.13248	0.02860	0.04229	2.5

Note: The applicant defined the normal working voltage is from 3.8Vdc to 4.3Vdc.

Frequency Error vs. Temperature

Voltage (Volts)	Frequency Error (ppm)					Limit (ppm)
	WCDMA Band 4	LTE Band 4	LTE Band 7	LTE Band 12	LTE Band 13	
50	0.02370	0.10858	0.11820	0.05057	0.00964	2.5
40	0.01688	0.06961	0.13080	0.00594	0.04408	2.5
30	0.00610	0.08438	0.14277	0.03227	0.00731	2.5
20	0.05160	0.04057	0.11911	0.03761	0.02806	2.5
10	0.00477	0.12382	0.10790	0.03433	0.04215	2.5
0	0.10021	0.06215	0.10527	0.00377	0.05153	2.5
-10	0.14235	0.01739	0.17628	0.01444	0.02758	2.5
-20	0.13326	0.00459	0.00426	0.04206	0.05282	2.5
-30	0.01949	0.04674	0.06986	0.01545	0.04674	2.5

Frequency Error vs. Voltage

Voltage (Volts)	Frequency Error (ppm)				Limit (ppm)
	LTE Band 17	LTE Band 38	LTE Band 41	LTE Band 66	
4.3	0.02898	0.04140	0.08642	0.11719	2.5
3.8	0.05436	0.00543	0.06582	0.05653	2.5
3.6	0.05412	0.03784	0.15617	0.04145	2.5

Note: The applicant defined the normal working voltage is from 3.8Vdc to 4.3Vdc.

Frequency Error vs. Temperature

Voltage (Volts)	Frequency Error (ppm)				Limit (ppm)
	LTE Band 17	LTE Band 38	LTE Band 41	LTE Band 66	
50	0.06225	0.07372	0.13584	0.07160	2.5
40	0.05668	0.02327	0.18456	0.00805	2.5
30	0.00379	0.02221	0.04842	0.09023	2.5
20	0.05436	0.00543	0.09498	0.05653	2.5
10	0.06712	0.07733	0.13595	0.09949	2.5
0	0.05925	0.02467	0.02495	0.11935	2.5
-10	0.02139	0.06103	0.11484	0.00553	2.5
-20	0.08165	0.09012	0.12485	0.09445	2.5

4.4 Emission Bandwidth Measurement

4.4.1 Limits of Emission Bandwidth Measurement

According to FCC 27.53(m)(6) specified that emission bandwidth is defined as the width of the signal between two points, one below the carrier center frequency and one above the carrier center frequency, outside of which all emissions are attenuated at least 26dB below the transmitter power.

4.4.2 Test Procedure

The transmitter output was connected to the spectrum analyzer through an attenuator. The bandwidth of the fundamental frequency was measured by spectrum analyzer with RBW = 30kHz and VBW = 100kHz (Channel Bandwidth: 1.4MHz), RBW = 51kHz and VBW = 150kHz (Channel Bandwidth: 3MHz and 5MHz), RBW = 100kHz and VBW = 300kHz (Channel Bandwidth: 10MHz), RBW = 200kHz and VBW = 620kHz (Channel Bandwidth: 15MHz) and RBW = 430kHz and VBW = 1.2MHz (Channel Bandwidth: 20MHz). The 26dB bandwidth is defined as the total spectrum the power of which is higher than peak power minus 26dB.

4.4.3 Test Setup

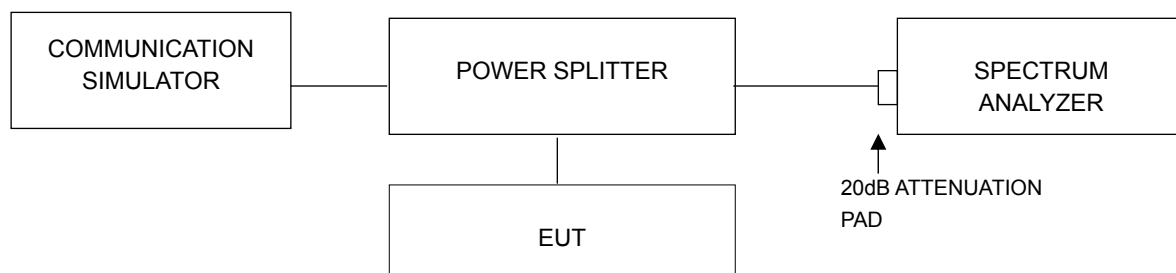

4.4.4 Test Result

WCDMA Band 4

Channel	Frequency (MHz)	26dBc Bandwidth (MHz)	Occupied Bandwidth (MHz)
		WCDMA	WCDMA
1312	1712.4	4.68	4.13
1413	1732.6	4.66	4.13
1513	1752.6	4.71	4.13

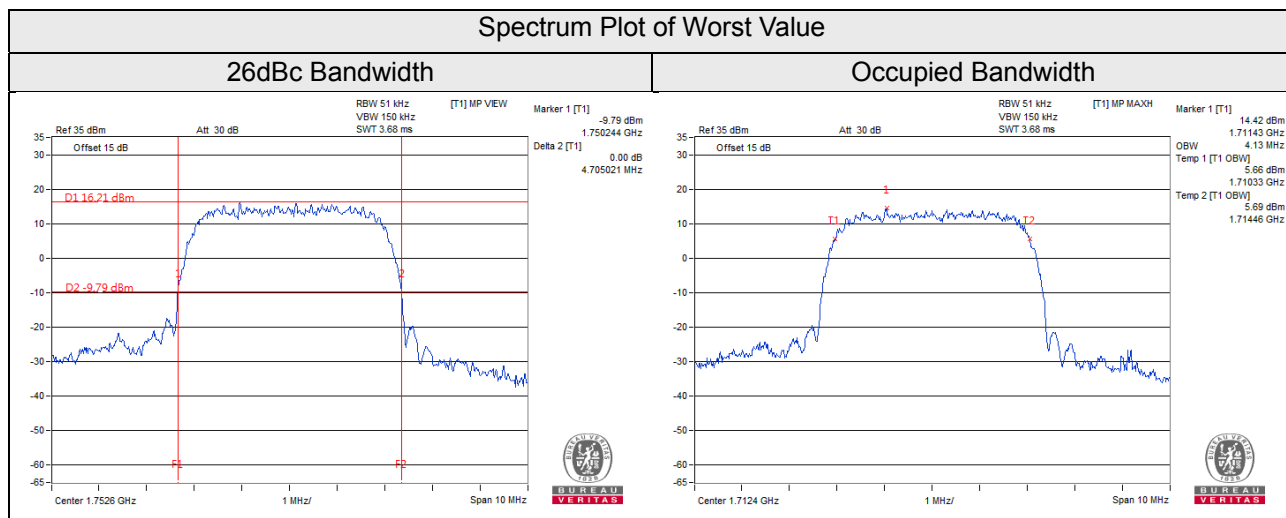

LTE Band 4

Channel Bandwidth: 1.4MHz							
Channel	Frequency (MHz)	26dBc Bandwidth (MHz)			Occupied Bandwidth (MHz)		
		QPSK	16QAM	64QAM	QPSK	16QAM	64QAM
19957	1710.7	1.235	1.247	1.233	1.09	1.09	1.09
20175	1732.5	1.233	1.229	1.242	1.09	1.08	1.09
20393	1754.3	1.233	1.231	1.220	1.09	1.09	1.09

Channel Bandwidth: 3MHz							
Channel	Frequency (MHz)	26dBc Bandwidth (MHz)			Occupied Bandwidth (MHz)		
		QPSK	16QAM	64QAM	QPSK	16QAM	64QAM
19965	1711.5	2.971	2.966	2.987	2.69	2.69	2.68
20175	1732.5	2.995	2.974	2.947	2.69	2.69	2.68
20385	1753.5	2.976	2.969	2.965	2.68	2.68	2.67

Channel Bandwidth: 5MHz							
Channel	Frequency (MHz)	26dBc Bandwidth (MHz)			Occupied Bandwidth (MHz)		
		QPSK	16QAM	64QAM	QPSK	16QAM	64QAM
19975	1712.5	4.917	4.900	4.848	4.45	4.46	4.46
20175	1732.5	4.910	4.894	4.884	4.45	4.45	4.48
20375	1752.5	4.889	4.886	4.849	4.48	4.46	4.48

Channel Bandwidth: 10MHz							
Channel	Frequency (MHz)	26dBc Bandwidth (MHz)			Occupied Bandwidth (MHz)		
		QPSK	16QAM	64QAM	QPSK	16QAM	64QAM
20000	1715.0	9.669	9.701	9.569	8.93	8.96	8.93
20175	1732.5	9.625	9.563	9.601	8.90	8.93	8.90
20350	1750.0	9.658	9.591	9.665	8.93	8.93	8.93

Channel Bandwidth: 15MHz							
Channel	Frequency (MHz)	26dBc Bandwidth (MHz)			Occupied Bandwidth (MHz)		
		QPSK	16QAM	64QAM	QPSK	16QAM	64QAM
20025	1717.5	14.565	14.489	14.478	13.36	13.36	13.36
20175	1732.5	14.555	14.401	14.446	13.40	13.36	13.40
20325	1747.5	14.508	14.529	14.560	13.43	13.40	13.40

Channel Bandwidth: 20MHz

Channel	Frequency (MHz)	26dBc Bandwidth (MHz)			Occupied Bandwidth (MHz)		
		QPSK	16QAM	64QAM	QPSK	16QAM	64QAM
20050	1720.0	19.579	19.544	19.455	17.93	17.86	17.86
20175	1732.5	19.380	19.491	19.456	17.86	17.86	17.86
20300	1745.0	19.562	19.540	19.516	17.93	17.93	17.93

26dBc Bandwidth

Spectrum Plot of Worst Value

1.4MHz / 16QAM

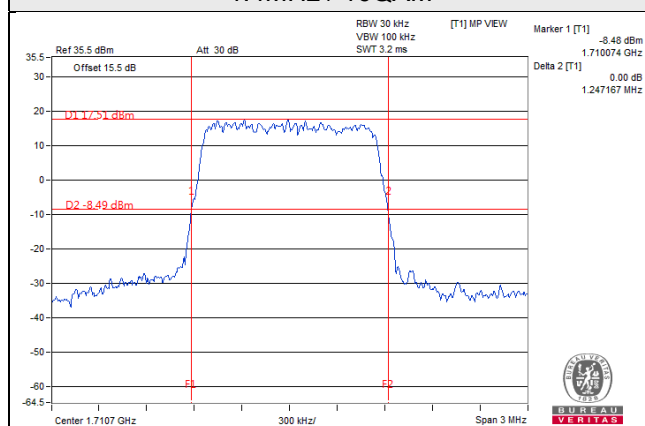

3MHz / QPSK

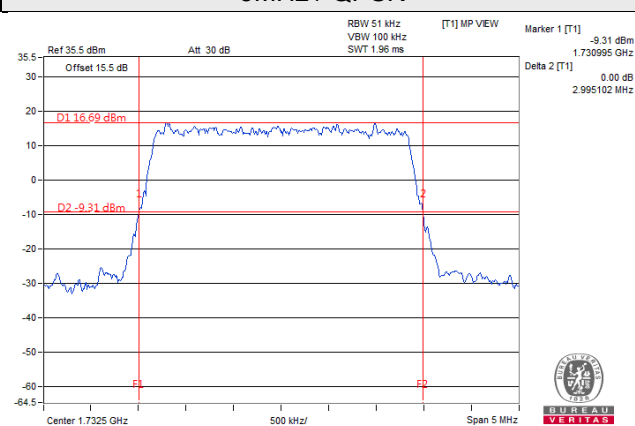

5MHz / QPSK

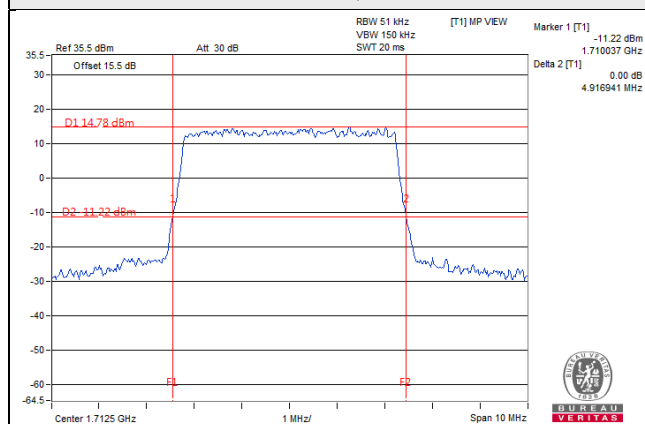

10MHz / 16QAM

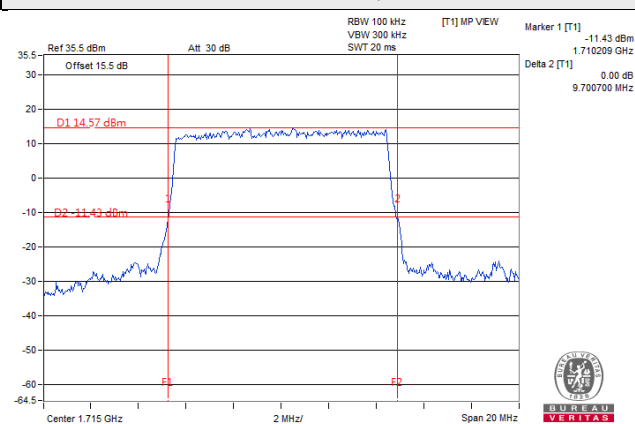

15MHz / QPSK

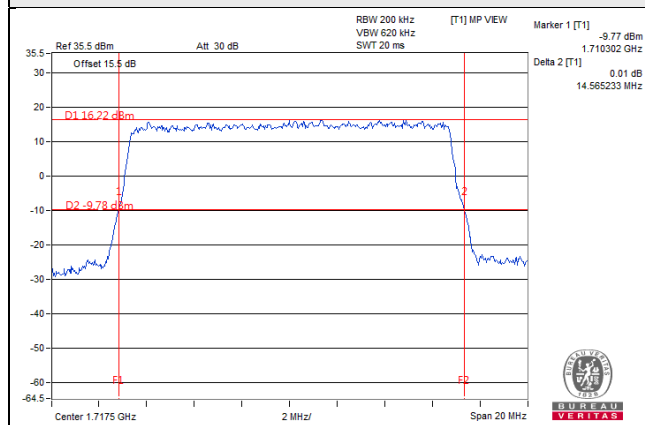

20MHz / QPSK

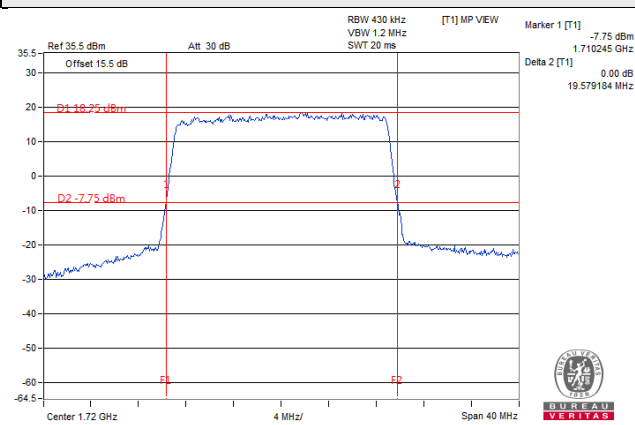

Occupied Bandwidth

Spectrum Plot of Worst Value

1.4MHz / 16QAM

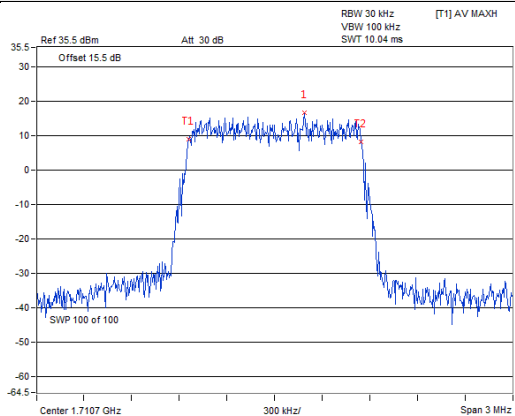

3MHz / QPSK

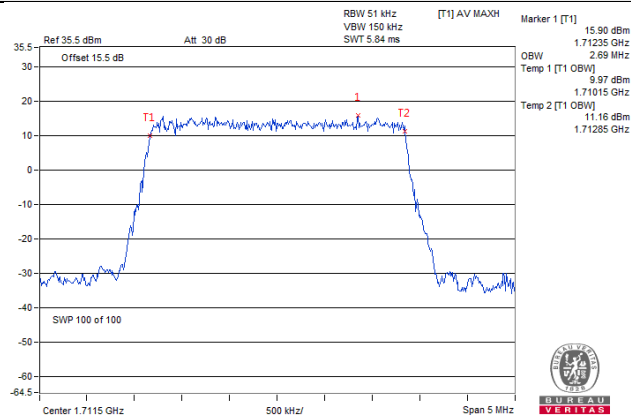

5MHz / QPSK

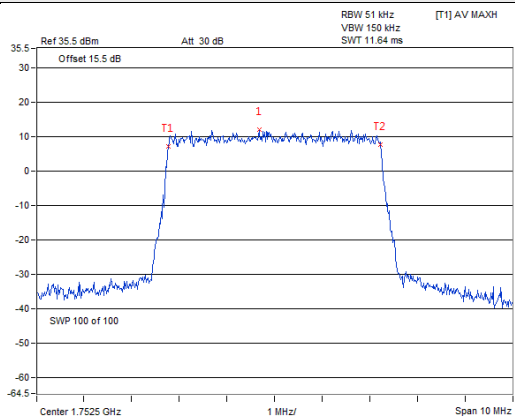

10MHz / 16QAM

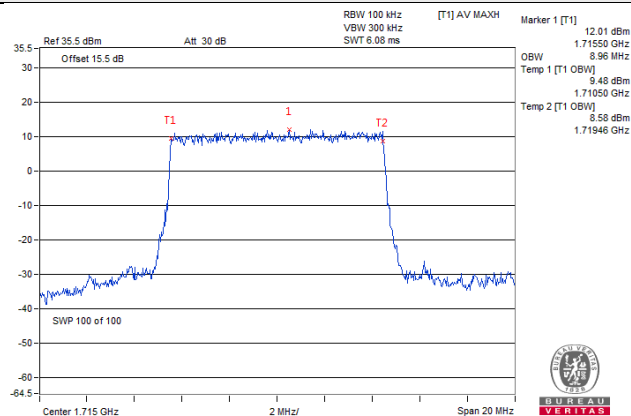

15MHz / QPSK

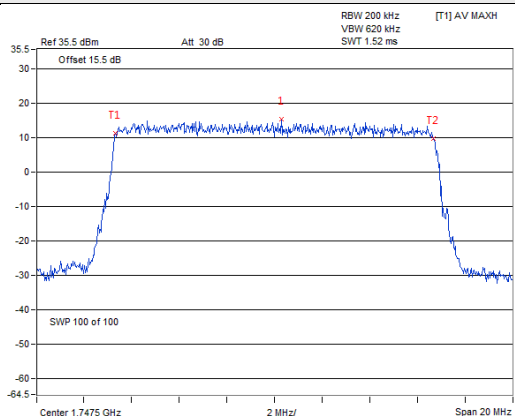

20MHz / QPSK

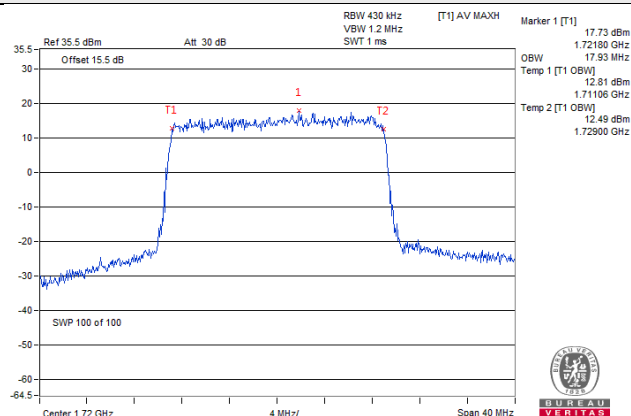

LTE Band 7

Channel Bandwidth: 5MHz							
Channel	Frequency (MHz)	26dBc Bandwidth (MHz)			Occupied Bandwidth (MHz)		
		QPSK	16QAM	64QAM	QPSK	16QAM	64QAM
20775	2502.5	4.869	4.916	4.933	4.48	4.48	4.48
21100	2535.0	4.896	4.895	4.877	4.48	4.48	4.48
21425	2567.5	4.891	4.911	4.855	4.48	4.48	4.48

Channel Bandwidth: 10MHz							
Channel	Frequency (MHz)	26dBc Bandwidth (MHz)			Occupied Bandwidth (MHz)		
		QPSK	16QAM	64QAM	QPSK	16QAM	64QAM
20800	2505.0	9.575	9.578	9.604	8.93	8.93	8.93
21100	2535.0	9.597	9.620	9.623	8.90	8.93	8.90
21400	2565.0	9.590	9.647	9.598	8.96	8.93	8.96

Channel Bandwidth: 15MHz							
Channel	Frequency (MHz)	26dBc Bandwidth (MHz)			Occupied Bandwidth (MHz)		
		QPSK	16QAM	64QAM	QPSK	16QAM	64QAM
20825	2507.5	14.542	14.504	14.398	13.40	13.40	13.43
21100	2535.0	14.507	14.487	14.481	13.40	13.40	13.36
21375	2562.5	14.471	14.536	14.443	13.40	13.40	13.40

Channel Bandwidth: 20MHz							
Channel	Frequency (MHz)	26dBc Bandwidth (MHz)			Occupied Bandwidth (MHz)		
		QPSK	16QAM	64QAM	QPSK	16QAM	64QAM
20850	2510.0	19.547	19.502	19.505	17.93	17.93	17.93
21100	2535.0	19.477	19.508	19.583	17.93	17.93	17.93
21350	2560.0	19.595	19.545	19.569	18.00	17.86	17.86

26Bc Bandwidth

Spectrum Plot of Worst Value

5MHz / 64QAM

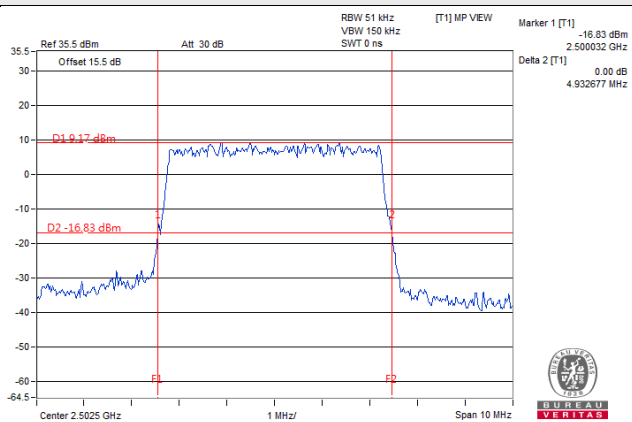

10MHz / 16QAM

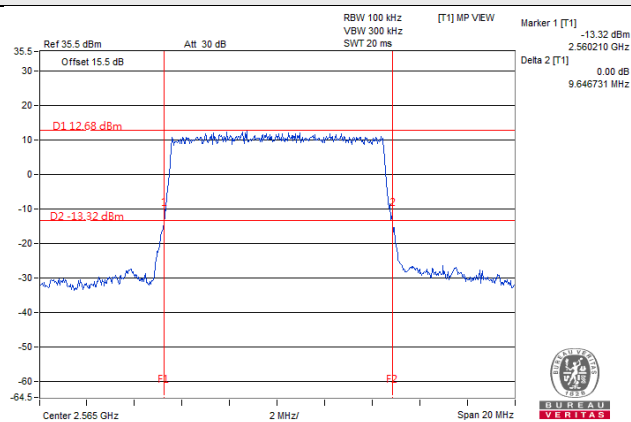

15MHz / QPSK

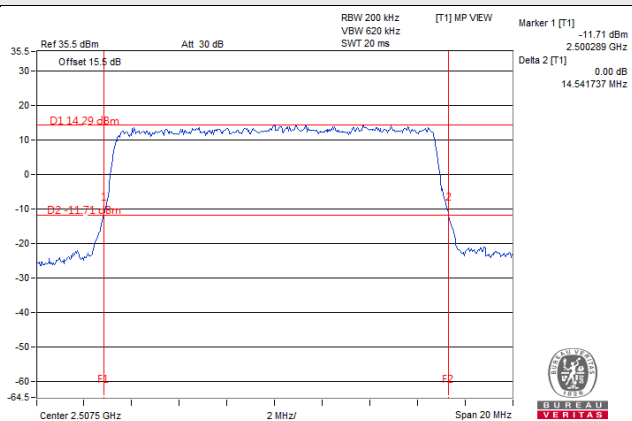

20MHz / QPSK

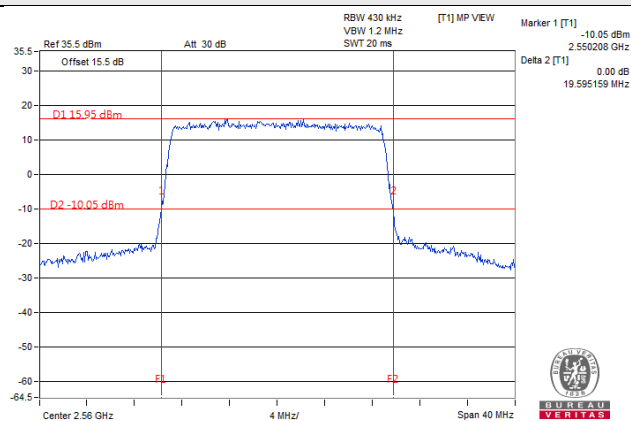

Occupied Bandwidth Spectrum Plot of Worst Value

5MHz / 64QAM

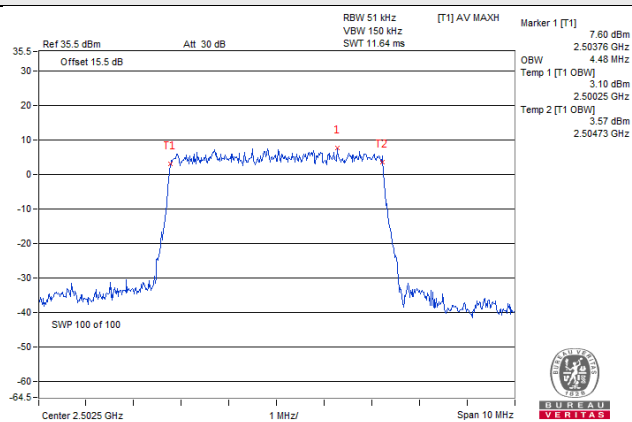

10MHz / 64QAM

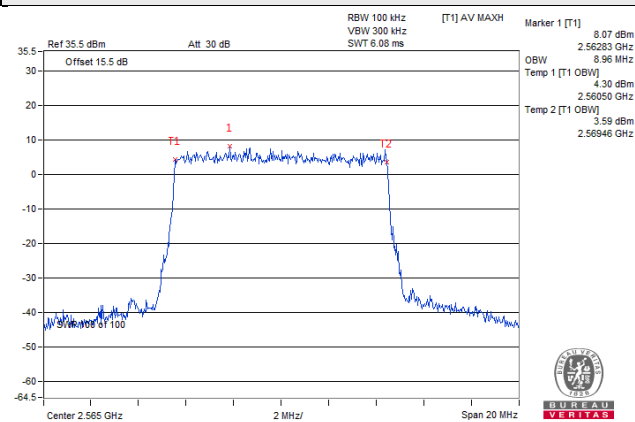

15MHz / 64QAM

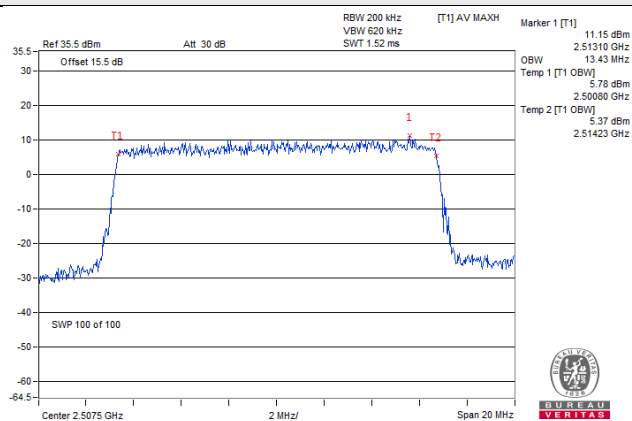

20MHz / QPSK

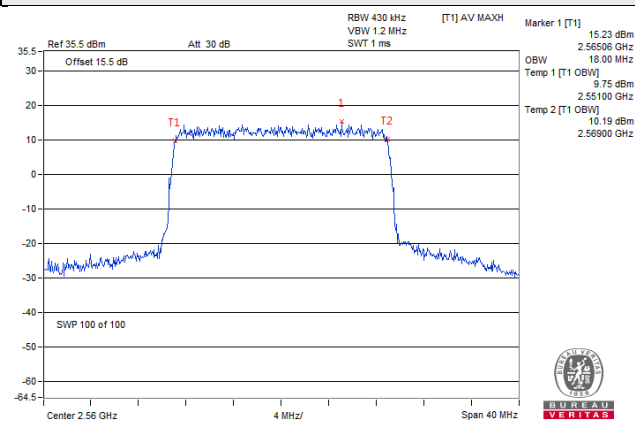

LTE Band 7

CA Mode

Channel Bandwidth: 20MHz+20MHz			
Channel	Frequency (MHz)	26dBc Bandwidth (MHz)	Occupied Bandwidth (MHz)
		QPSK	QPSK
20850+21048	2510.0MHz+2529.8MHz	39.63	37.60
21100+21298	2535.0MHz+2554.8MHz	39.70	37.60
21350+21152	2560.0MHz+2540.2MHz	39.71	37.64

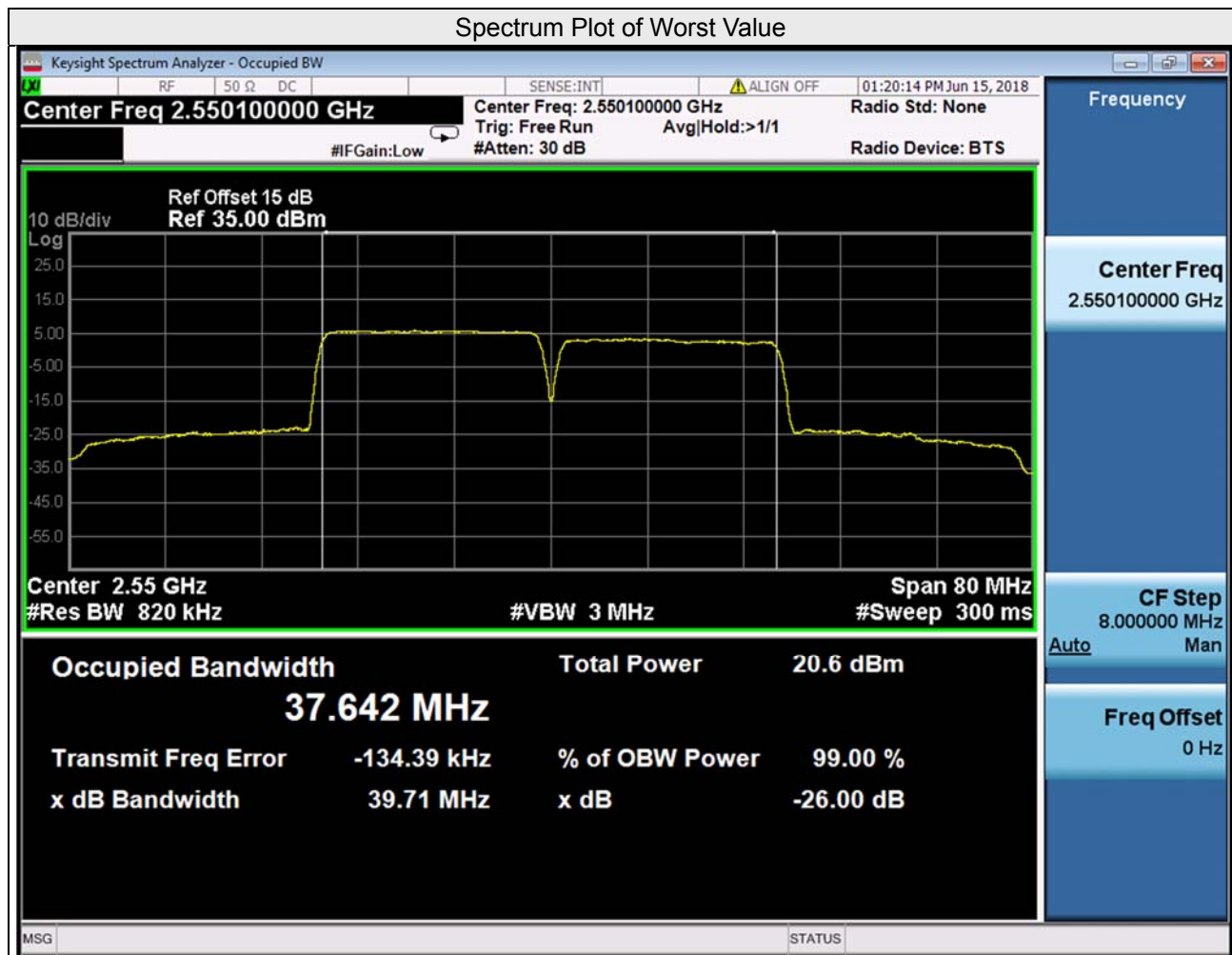

LTE Band 12

Channel Bandwidth: 1.4MHz							
Channel	Frequency (MHz)	26dBc Bandwidth (MHz)			Occupied Bandwidth (MHz)		
		QPSK	16QAM	64QAM	QPSK	16QAM	64QAM
23017	699.7	1.227	1.219	1.222	1.08	1.09	1.09
23095	707.5	1.232	1.244	1.237	1.09	1.09	1.09
23173	715.3	1.242	1.235	1.233	1.09	1.09	1.09

Channel Bandwidth: 3MHz							
Channel	Frequency (MHz)	26dBc Bandwidth (MHz)			Occupied Bandwidth (MHz)		
		QPSK	16QAM	64QAM	QPSK	16QAM	64QAM
23025	700.5	2.965	3.005	2.929	2.69	2.68	2.67
23095	707.5	2.965	2.987	2.988	2.69	2.69	2.68
23165	714.5	2.956	2.947	2.934	2.67	2.68	2.67

Channel Bandwidth: 5MHz							
Channel	Frequency (MHz)	26dBc Bandwidth (MHz)			Occupied Bandwidth (MHz)		
		QPSK	16QAM	64QAM	QPSK	16QAM	64QAM
23035	701.5	4.900	4.861	4.810	4.48	4.48	4.50
23095	707.5	4.873	4.890	4.872	4.46	4.45	4.46
23155	713.5	4.888	4.915	4.847	4.48	4.48	4.46

Channel Bandwidth: 10MHz							
Channel	Frequency (MHz)	26dBc Bandwidth (MHz)			Occupied Bandwidth (MHz)		
		QPSK	16QAM	64QAM	QPSK	16QAM	64QAM
23060	704	9.616	9.600	9.513	8.93	8.93	8.90
23095	707.5	9.488	9.578	9.534	8.90	8.90	8.93
23130	711	9.691	9.657	9.663	8.96	8.96	8.96

26dBc Bandwidth

Spectrum Plot of Worst Value

1.4MHz / 16QAM

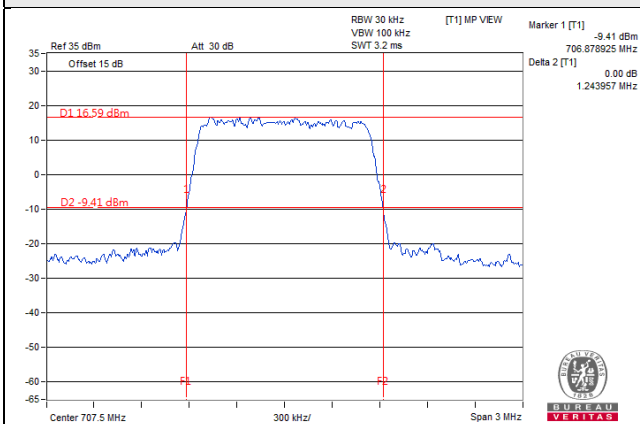

3MHz / 16QAM

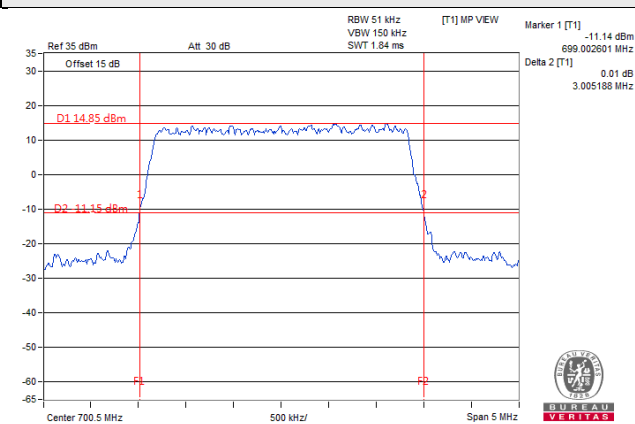

5MHz / 16QAM

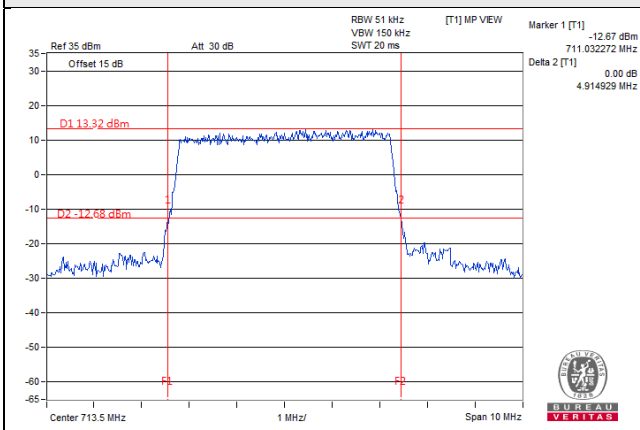

10MHz / QPSK

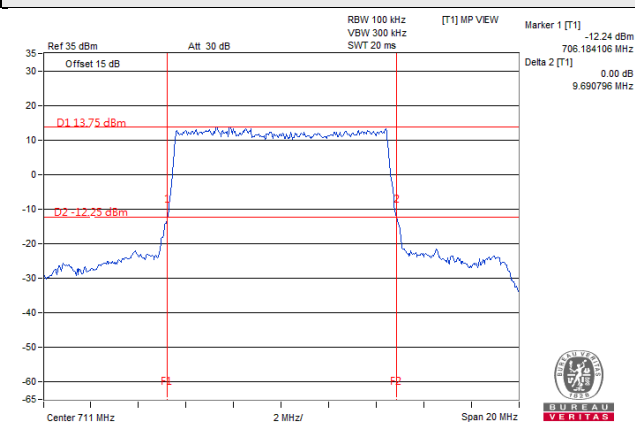

Occupied Bandwidth Spectrum Plot of Worst Value

1.4MHz / 16QAM

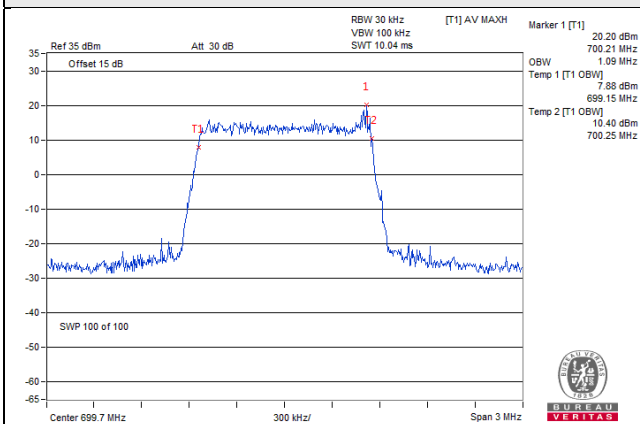

3MHz / 16QAM

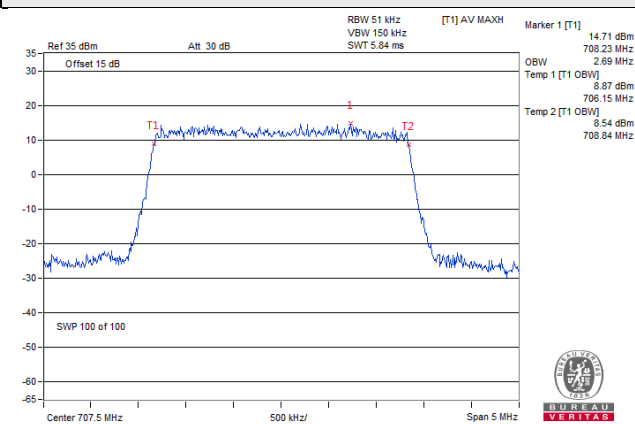

5MHz / 64QAM

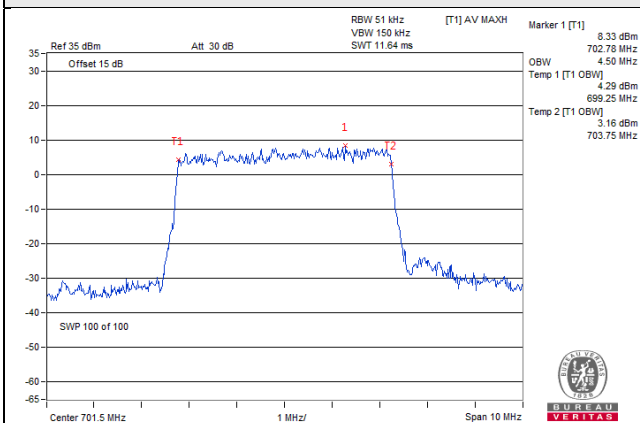

10MHz / QPSK

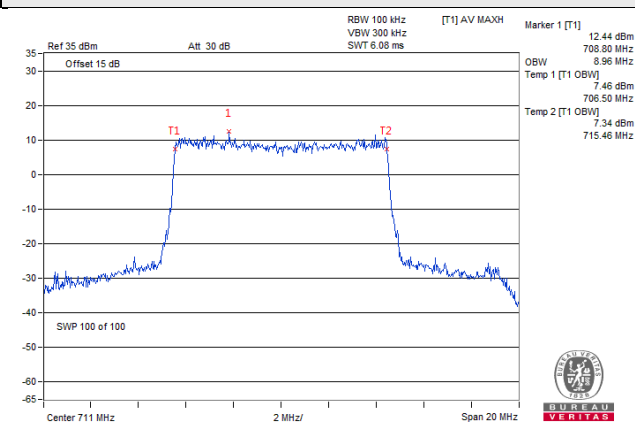

LTE Band 13

Channel Bandwidth: 5MHz							
Channel	Frequency (MHz)	26dBc Bandwidth (MHz)			Occupied Bandwidth (MHz)		
		QPSK	16QAM	64QAM	QPSK	16QAM	64QAM
23205	779.5	4.886	4.885	4.817	4.48	4.46	4.46
23230	782.0	4.930	4.886	4.840	4.48	4.46	4.48
23255	784.5	4.904	4.909	4.887	4.45	4.48	4.48

Channel Bandwidth: 10MHz							
Channel	Frequency (MHz)	26dBc Bandwidth (MHz)			Occupied Bandwidth (MHz)		
		QPSK	16QAM	64QAM	QPSK	16QAM	64QAM
23230	782.0	9.646	9.582	9.573	8.93	8.93	8.93

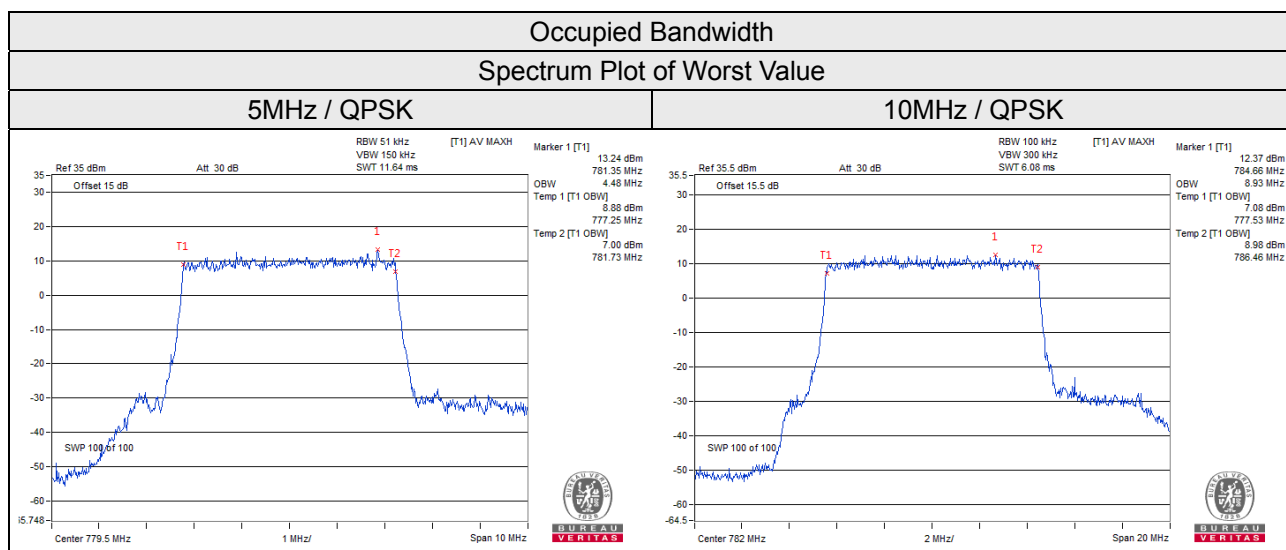
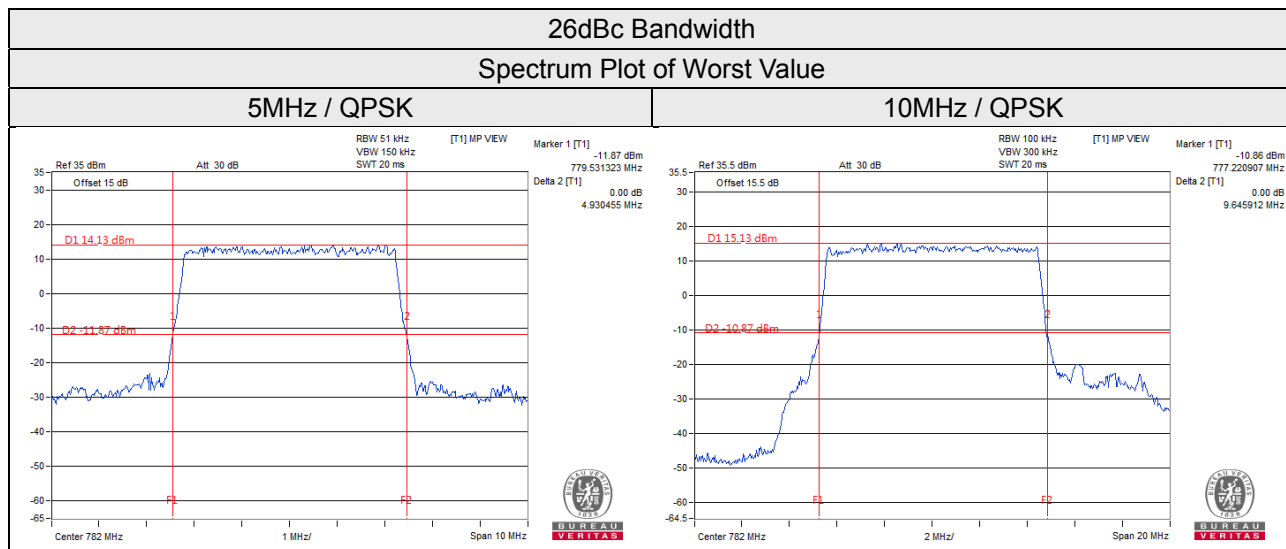

LTE Band 17

Channel Bandwidth: 5MHz							
Channel	Frequency (MHz)	26dBc Bandwidth (MHz)			Occupied Bandwidth (MHz)		
		QPSK	16QAM	64QAM	QPSK	16QAM	64QAM
23755	706.5	4.871	4.838	4.860	4.46	4.46	4.46
23790	710.0	4.895	4.881	4.889	4.48	4.48	4.48
23825	713.5	4.863	4.876	4.839	4.46	4.46	4.46

Channel Bandwidth: 10MHz							
Channel	Frequency (MHz)	26dBc Bandwidth (MHz)			Occupied Bandwidth (MHz)		
		QPSK	16QAM	64QAM	QPSK	16QAM	64QAM
23780	709.0	9.634	9.711	9.565	8.96	8.96	8.96
23790	710.0	9.609	9.660	9.256	8.96	8.96	8.96
23800	711.0	9.693	9.758	9.559	8.96	9.00	8.96

26dBc Bandwidth

Spectrum Plot of Worst Value

5MHz / QPSK

10MHz / 16QAM

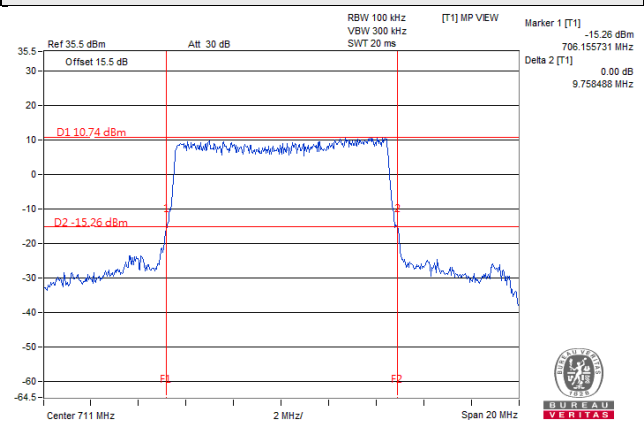
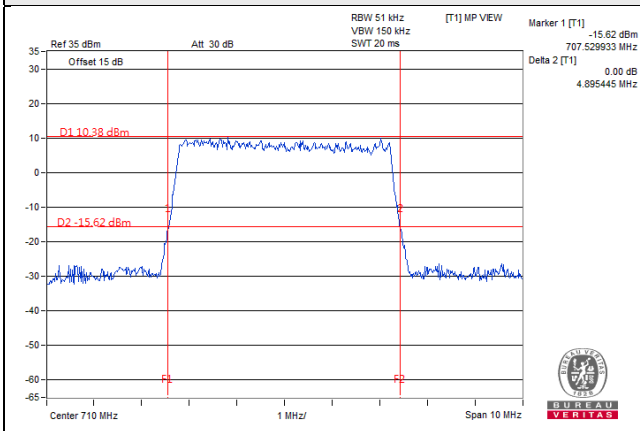

Occupied Bandwidth

Spectrum Plot of Worst Value

5MHz / QPSK

10MHz / 16QAM

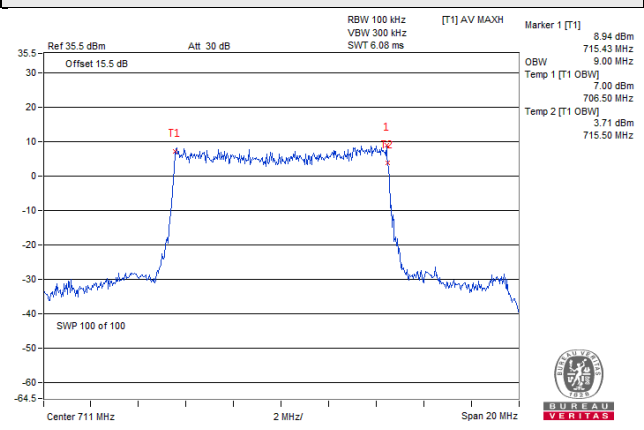
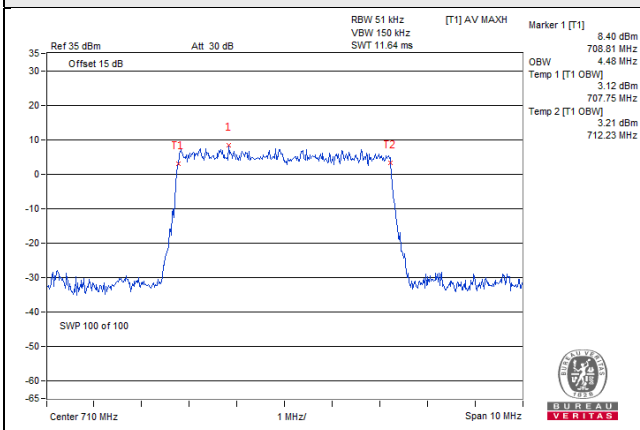

LTE Band 38

Channel Bandwidth: 5MHz							
Channel	Frequency (MHz)	26dBc Bandwidth (MHz)			Occupied Bandwidth (MHz)		
		QPSK	16QAM	64QAM	QPSK	16QAM	64QAM
37775	2572.5	4.820	4.866	4.869	4.46	4.45	4.45
38000	2595.0	4.850	4.868	4.888	4.45	4.45	4.45
38225	2617.5	4.903	4.905	4.901	4.45	4.45	4.46

Channel Bandwidth: 10MHz							
Channel	Frequency (MHz)	26dBc Bandwidth (MHz)			Occupied Bandwidth (MHz)		
		QPSK	16QAM	64QAM	QPSK	16QAM	64QAM
37800	2575.0	9.548	9.580	9.487	8.96	8.90	8.90
38000	2595.0	9.584	9.544	9.577	8.90	8.93	8.90
38200	2615.0	9.530	9.507	9.549	8.86	8.90	8.93

Channel Bandwidth: 15MHz							
Channel	Frequency (MHz)	26dBc Bandwidth (MHz)			Occupied Bandwidth (MHz)		
		QPSK	16QAM	64QAM	QPSK	16QAM	64QAM
37825	2577.5	14.359	14.402	14.444	13.36	13.36	13.40
38000	2595.0	14.335	14.400	14.349	13.40	13.36	13.36
38175	2612.5	14.371	14.392	14.350	13.43	13.36	13.36

Channel Bandwidth: 20MHz							
Channel	Frequency (MHz)	26dBc Bandwidth (MHz)			Occupied Bandwidth (MHz)		
		QPSK	16QAM	64QAM	QPSK	16QAM	64QAM
37850	2580.0	19.364	19.532	19.498	17.86	17.93	17.93
38000	2595.0	19.497	19.342	19.279	17.93	17.86	17.93
38150	2610.0	19.371	19.514	19.515	17.80	17.93	17.86

26dBc Bandwidth

Spectrum Plot of Worst Value

5MHz / 16QAM

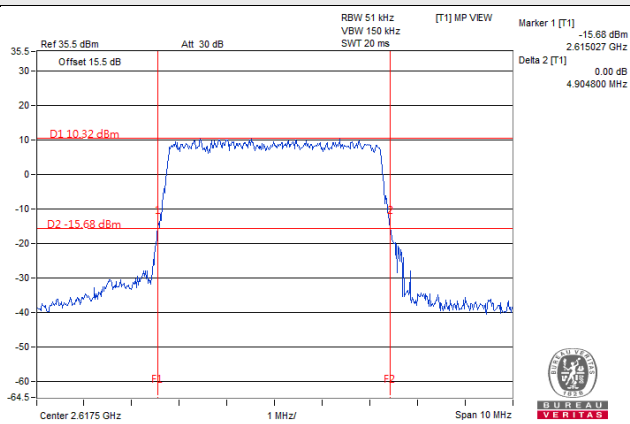

10MHz / QPSK

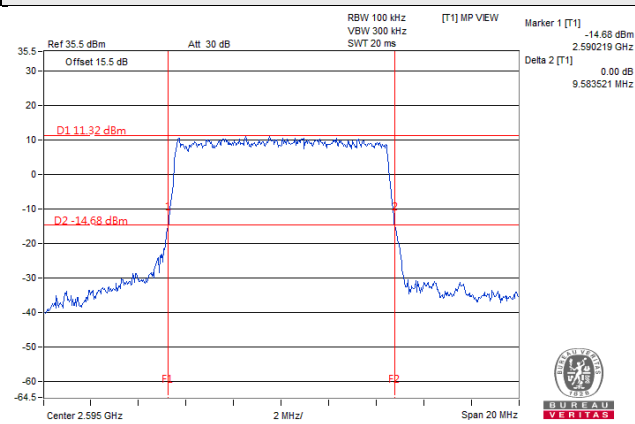

15MHz / 64QAM

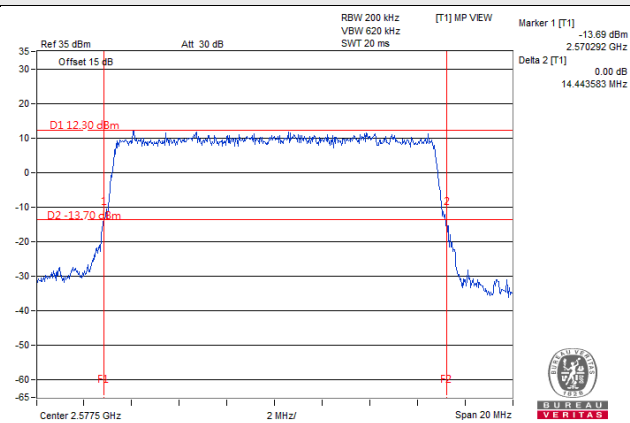

20MHz / 16QAM

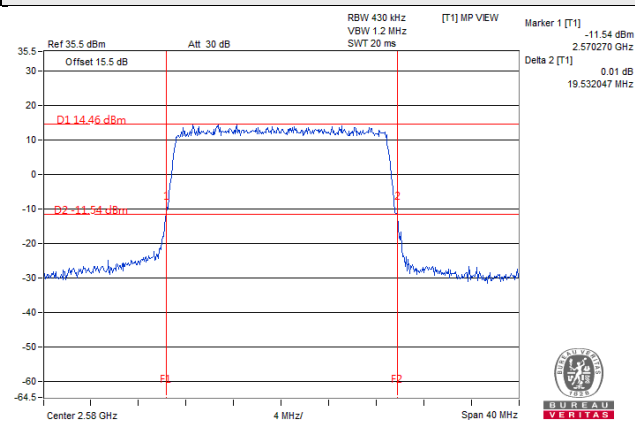

Occupied Bandwidth

Spectrum Plot of Worst Value

5MHz / 64QAM

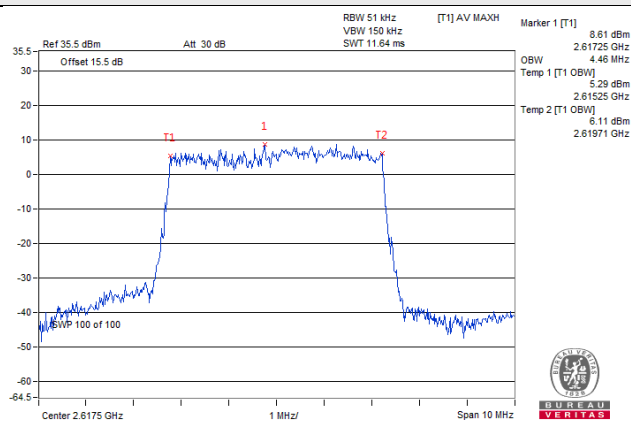

10MHz / QPSK

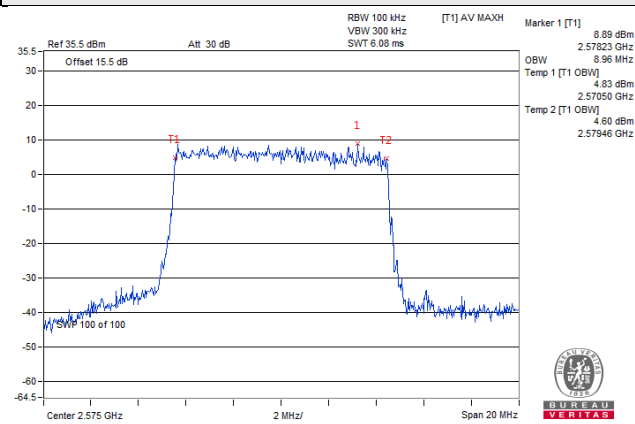

15MHz / QPSK

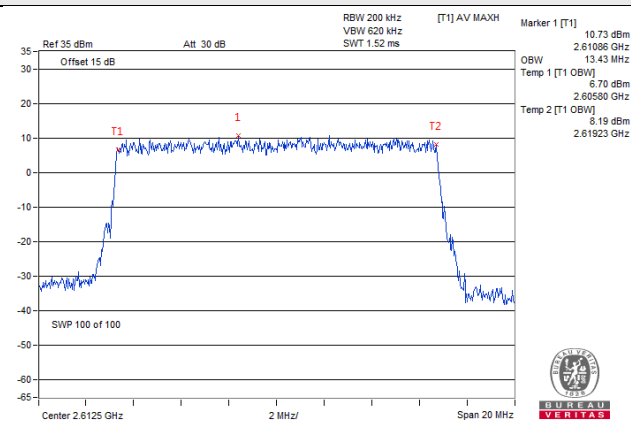

20MHz / 16QAM

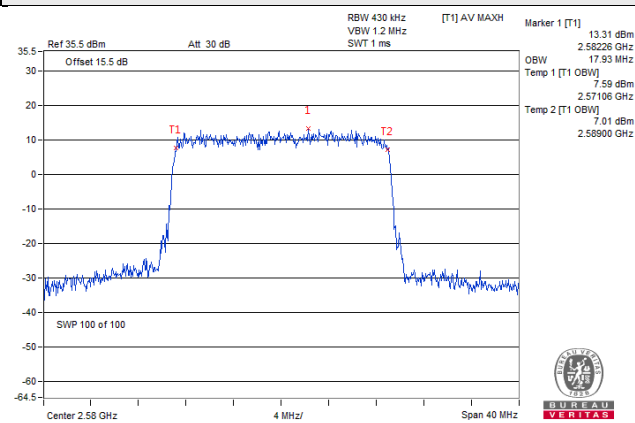

LTE Band 41

Channel Bandwidth: 5MHz							
Channel	Frequency (MHz)	26dBc Bandwidth (MHz)			Occupied Bandwidth (MHz)		
		QPSK	16QAM	64QAM	QPSK	16QAM	64QAM
40065	2537.5	4.899	4.897	4.893	4.45	4.48	4.45
40640	2595.0	4.920	4.903	4.894	4.46	4.45	4.48
41215	2652.5	4.903	4.915	4.892	4.45	4.43	4.46

Channel Bandwidth: 10MHz							
Channel	Frequency (MHz)	26dBc Bandwidth (MHz)			Occupied Bandwidth (MHz)		
		QPSK	16QAM	64QAM	QPSK	16QAM	64QAM
40090	2540.0	9.516	9.549	9.615	8.93	8.90	8.96
40640	2595.0	9.546	9.494	9.546	8.93	8.90	8.93
41190	2650.0	9.547	9.570	9.590	8.93	8.96	8.96

Channel Bandwidth: 15MHz							
Channel	Frequency (MHz)	26dBc Bandwidth (MHz)			Occupied Bandwidth (MHz)		
		QPSK	16QAM	64QAM	QPSK	16QAM	64QAM
40115	2542.5	14.411	14.444	14.411	13.43	13.40	13.43
40640	2595.0	14.418	14.356	14.451	13.33	13.40	13.40
41165	2647.5	14.426	14.358	14.385	13.40	13.36	13.40

Channel Bandwidth: 20MHz							
Channel	Frequency (MHz)	26dBc Bandwidth (MHz)			Occupied Bandwidth (MHz)		
		QPSK	16QAM	64QAM	QPSK	16QAM	64QAM
40140	2545.0	19.518	19.337	19.518	17.86	17.93	17.93
40640	2595.0	19.324	19.565	19.509	17.86	18.00	17.93
41140	2645.0	19.551	19.460	19.566	17.86	17.93	17.86

26dBc Bandwidth

Spectrum Plot of Worst Value

5MHz / 16QAM

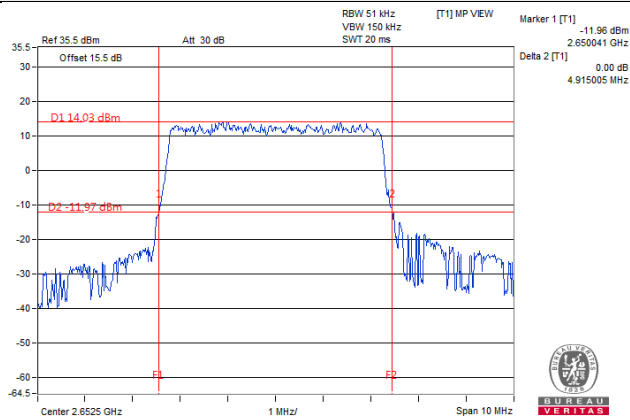

10MHz / 64QAM

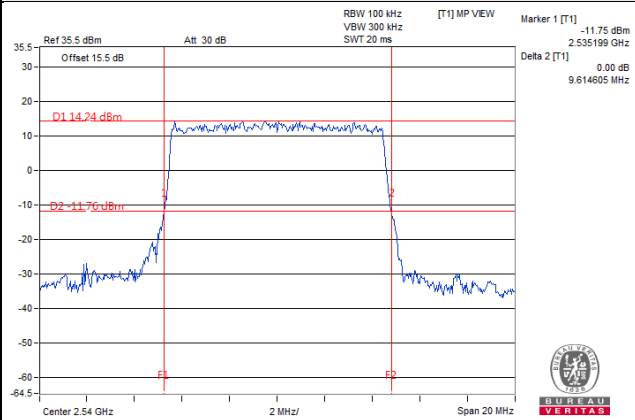

15MHz / 64QAM

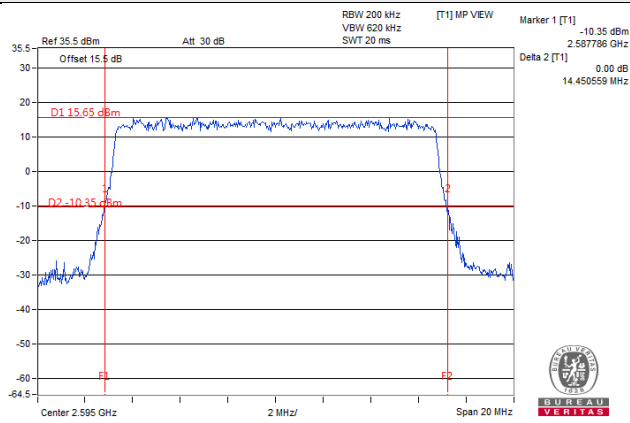

20MHz / 64QAM

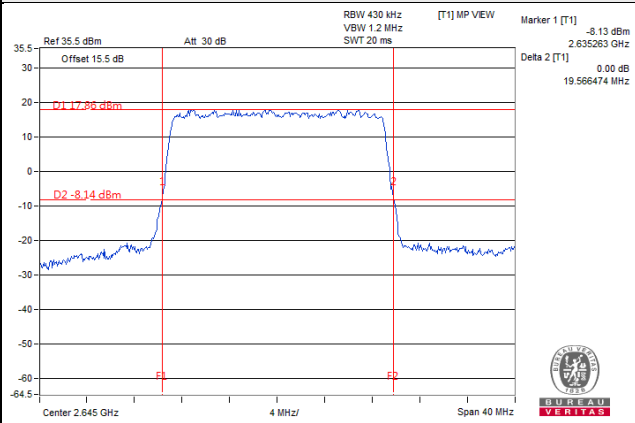

Occupied Bandwidth

Spectrum Plot of Worst Value

5MHz / 16QAM

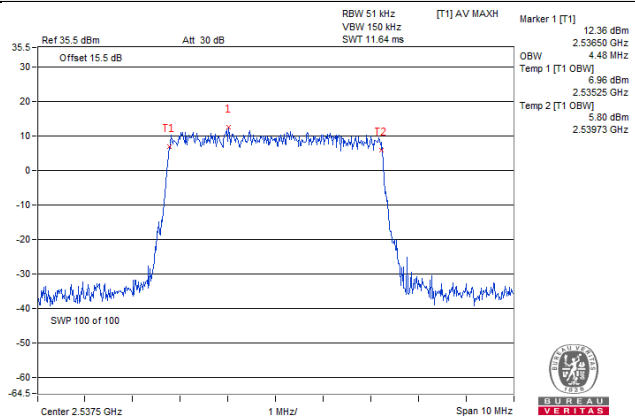

10MHz / 64QAM

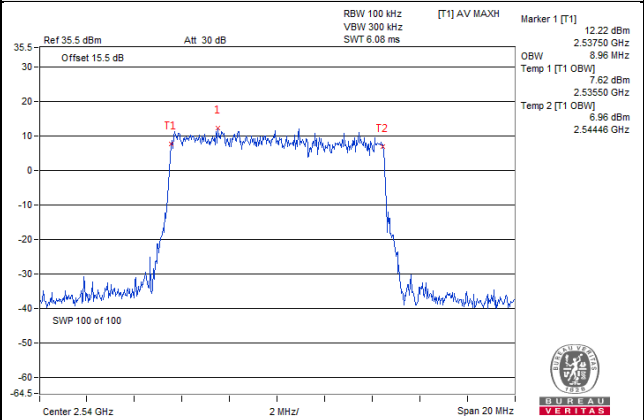

15MHz / 64QAM

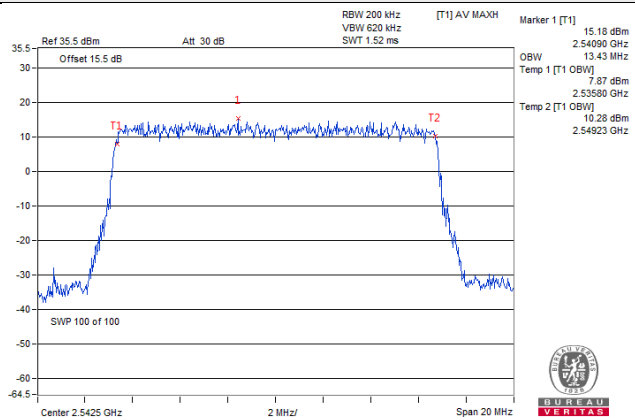

20MHz / 16QAM

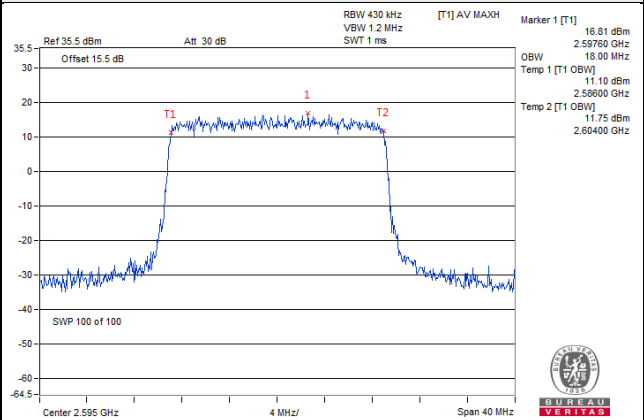

LTE Band 66

Channel Bandwidth: 1.4MHz							
Channel	Frequency (MHz)	26dBc Bandwidth (MHz)			Occupied Bandwidth (MHz)		
		QPSK	16QAM	64QAM	QPSK	16QAM	64QAM
131979	1710.7	1.234	1.239	1.233	1.08	1.09	1.09
132322	1745.0	1.231	1.233	1.236	1.08	1.09	1.09
132665	1779.3	1.240	1.245	1.241	1.08	1.09	1.08

Channel Bandwidth: 3MHz							
Channel	Frequency (MHz)	26dBc Bandwidth (MHz)			Occupied Bandwidth (MHz)		
		QPSK	16QAM	64QAM	QPSK	16QAM	64QAM
131987	1711.5	2.980	2.950	2.954	2.68	2.69	2.68
132322	1745.0	2.984	2.991	2.969	2.69	2.68	2.68
132657	1778.5	2.982	2.976	3.004	2.69	2.69	2.68

Channel Bandwidth: 5MHz							
Channel	Frequency (MHz)	26dBc Bandwidth (MHz)			Occupied Bandwidth (MHz)		
		QPSK	16QAM	64QAM	QPSK	16QAM	64QAM
131997	1712.5	4.895	4.890	4.901	4.45	4.46	4.48
132322	1745.0	4.897	4.893	4.924	4.46	4.46	4.48
132647	1777.5	4.925	4.898	4.931	4.46	4.46	4.48

Channel Bandwidth: 10MHz							
Channel	Frequency (MHz)	26dBc Bandwidth (MHz)			Occupied Bandwidth (MHz)		
		QPSK	16QAM	64QAM	QPSK	16QAM	64QAM
132022	1715.0	9.583	9.647	9.631	8.93	8.93	8.93
132322	1745.0	9.665	9.615	9.545	8.90	8.93	8.93
132622	1775.0	9.598	9.684	9.636	8.90	8.93	8.93

Channel Bandwidth: 15MHz							
Channel	Frequency (MHz)	26dBc Bandwidth (MHz)			Occupied Bandwidth (MHz)		
		QPSK	16QAM	64QAM	QPSK	16QAM	64QAM
132047	1717.5	14.521	14.473	14.521	13.36	13.40	13.40
132322	1745.0	14.448	14.545	14.448	13.43	13.40	13.40
132597	1772.5	14.423	14.477	14.423	13.40	13.43	13.36

Channel Bandwidth: 20MHz							
Channel	Frequency (MHz)	26dBc Bandwidth (MHz)			Occupied Bandwidth (MHz)		
		QPSK	16QAM	64QAM	QPSK	16QAM	64QAM
132072	1720.0	19.539	19.470	19.510	17.86	17.93	17.86
132322	1745.0	19.573	19.490	19.535	18.00	17.86	17.93
132572	1770.0	19.563	19.498	19.449	17.93	17.93	18.00

26dBc Bandwidth
Spectrum Plot of Worst Value

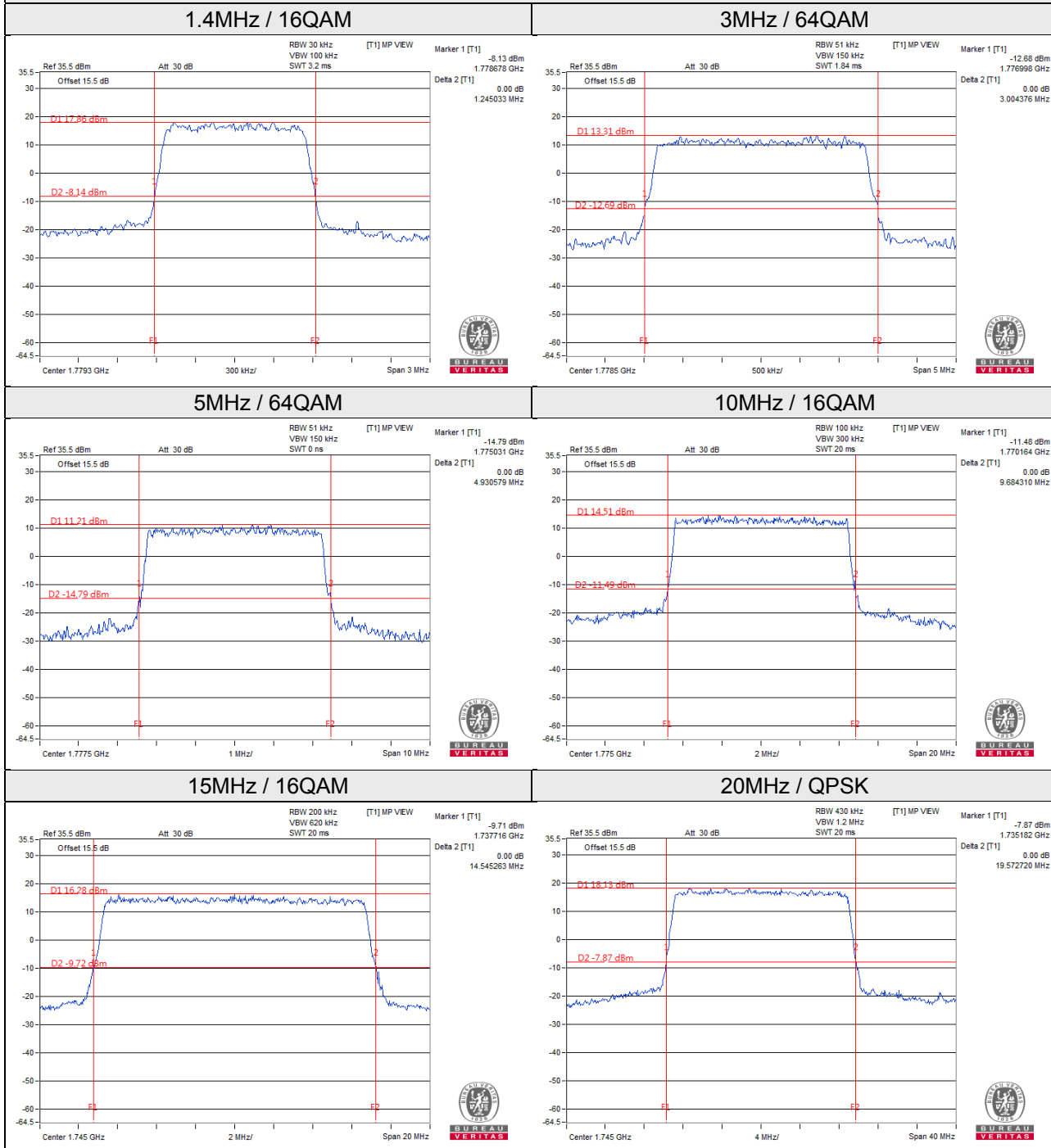

Occupied Bandwidth Spectrum Plot of Worst Value

1.4MHz / 16QAM

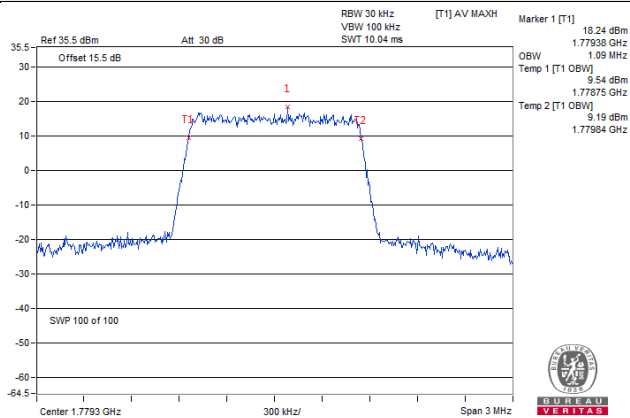

3MHz / 16QAM

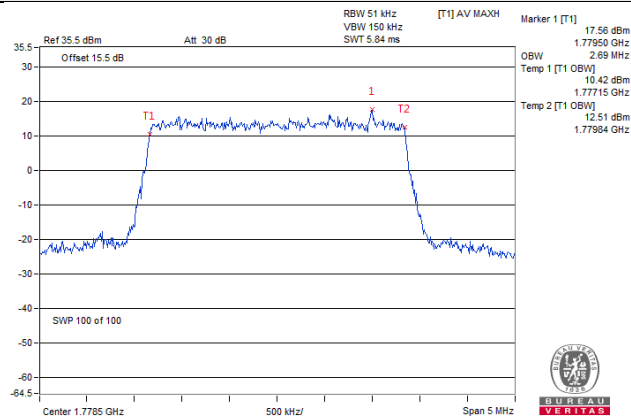

5MHz / 64QAM

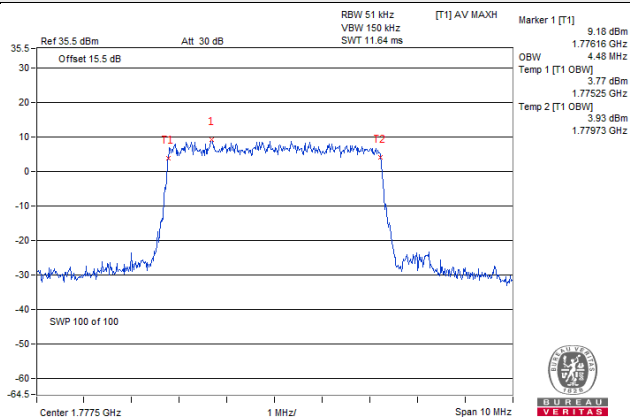

10MHz / 16QAM

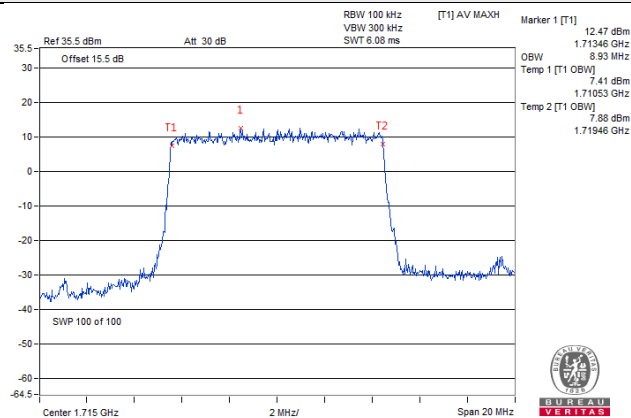

15MHz / QPSK

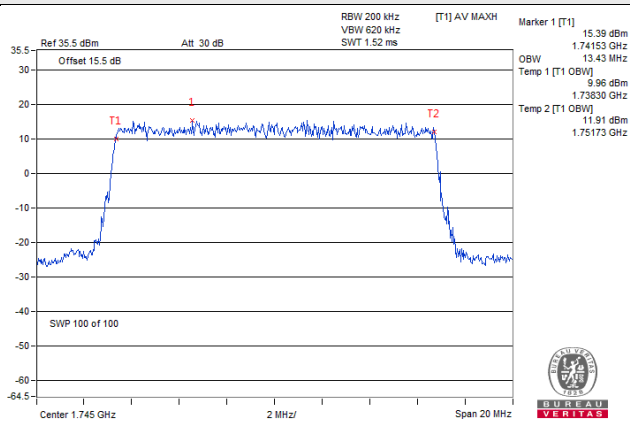

20MHz / QPSK

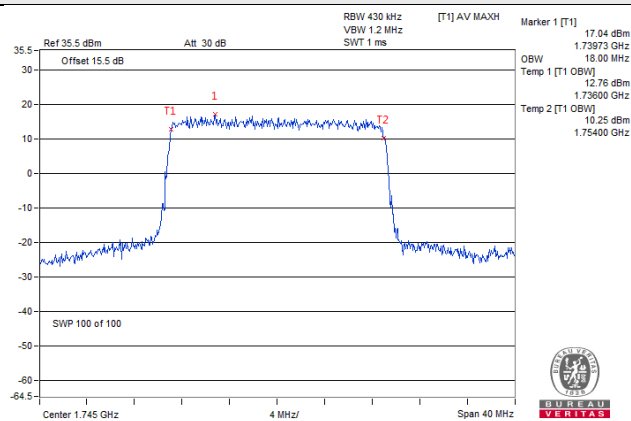

4.5 Channel Edge Measurement

4.5.1 Limits of Band Edge Measurement

For WCDMA Band 4, LTE Band 4, 66

According to FCC 27.53(h) for operations in the 1695-1710 MHz, 1710-1755 MHz, 1755-1780 MHz, 1915-1920 MHz, 1995-2000 MHz, 2000-2020 MHz, 2110-2155 MHz, 2155-2180 MHz, and 2180-2200 bands, the power of any emission outside a licensee's frequency block shall be attenuated below the transmitter power (P) in watts by at least $43 + 10 \log_{10}(P)$ dB.

For LTE Band 7, 38, 41

According to FCC 27.53(l)(4) specified that power of any emission outside of the channel edge must be attenuated below the transmitting power (P) by a factor shall be not less than $40 + 10 \log(P)$ dB on all frequencies between the channel edge and 5 megahertz from the channel edge, $43 + 10 \log(P)$ dB on all frequencies between 5 megahertz and X megahertz from the channel edge, and $55 + 10 \log(P)$ dB on all frequencies more than X megahertz from the channel edge, where X is the greater of 6 megahertz or the actual emission bandwidth. In addition, the attenuation factor shall not be less that $43 + 10 \log(P)$ dB on all frequencies between 2490.5 MHz and 2496 MHz and $55 + 10 \log(P)$ dB at or below 2490.5 MHz. In the 1 MHz bands immediately outside and adjacent to the frequency block a resolution bandwidth of at least two percent may be employed, except when the 1 megahertz band is 2495-2496 MHz, in which case a resolution bandwidth of at least one percent may be employed.

For LTE Band 12

According to FCC 27.53(g) for operations in the 600 MHz band and the 698-746 MHz band, the power of any emission outside a licensee's frequency band(s) of operation shall be attenuated below the transmitter power (P) within the licensed band(s) of operation, measured in watts, by at least $43 + 10 \log(P)$ dB. Compliance with this provision is based on the use of measurement instrumentation employing a resolution bandwidth of 100 kilohertz or greater.

For LTE Band 13

According to FCC 27.53(c)(2) for on any frequency outside the 776-788 MHz band, the power of any emission shall be attenuated outside the band below the transmitter power (P) by at least $43 + 10 \log(P)$ dB.

For LTE Band 17

According to FCC 27.53(g) for operations in the 600 MHz band and the 698-746 MHz band, the power of any emission outside a licensee's frequency band(s) of operation shall be attenuated below the transmitter power (P) within the licensed band(s) of operation, measured in watts, by at least $43 + 10 \log(P)$ dB. Compliance with this provision is based on the use of measurement instrumentation employing a resolution bandwidth of 100 kilohertz or greater.

4.5.2 Test Setup

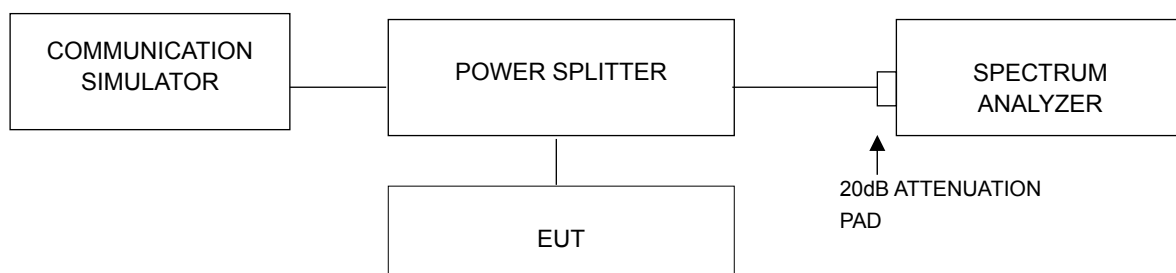

4.5.3 Test Procedures

- The EUT was set up for the rated peak power. The power was measured with Spectrum Analyzer. All measurements were done at 3 channels: low, middle and high operational frequency range.
- The center frequency of spectrum is the band edge frequency and span is 1.5MHz. RBW = 30kHz and VBW = 100kHz (Channel Bandwidth: 1.4MHz and 3MHz), RBW = 51kHz and VBW = 150kHz (Channel Bandwidth: 5MHz), RBW = 100kHz and VBW = 300kHz (Channel Bandwidth: 10MHz), RBW = 200kHz and VBW = 620kHz (Channel Bandwidth: 15MHz) and RBW = 430kHz and VBW = 1.2MHz (Channel Bandwidth: 20MHz).
- Record the max trace plot into the test report.

4.5.4 Test Results

WCDMA Band 4

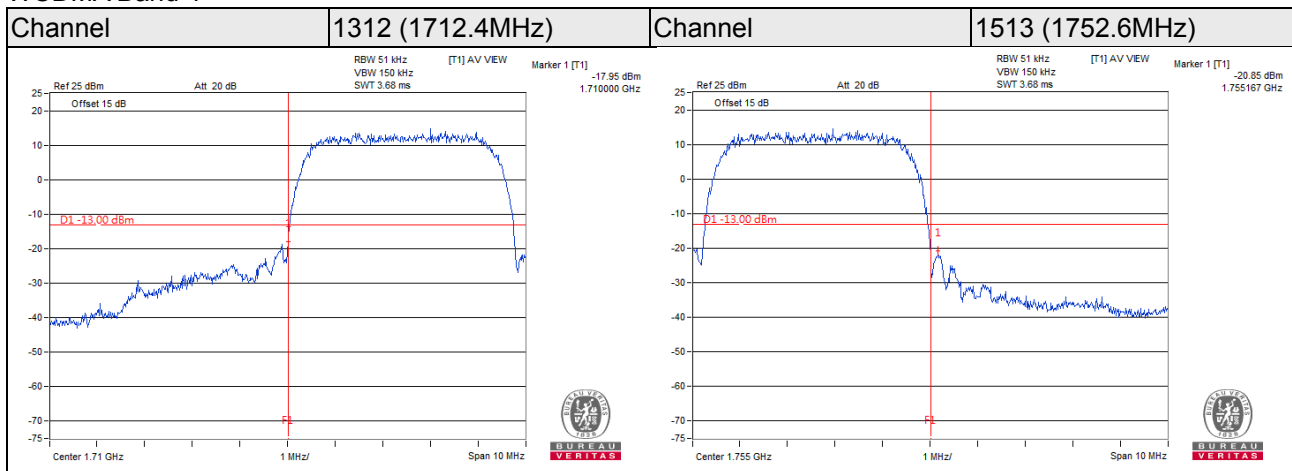

LTE Band 4

Channel Bandwidth: 1.4MHz

Channel 19957 (1710.7MHz)	QPSK	1 RB / 0 RB Offset	Channel 20393 (1754.3MHz)	QPSK	1 RB / 5 RB Offset
------------------------------	------	--------------------	------------------------------	------	--------------------

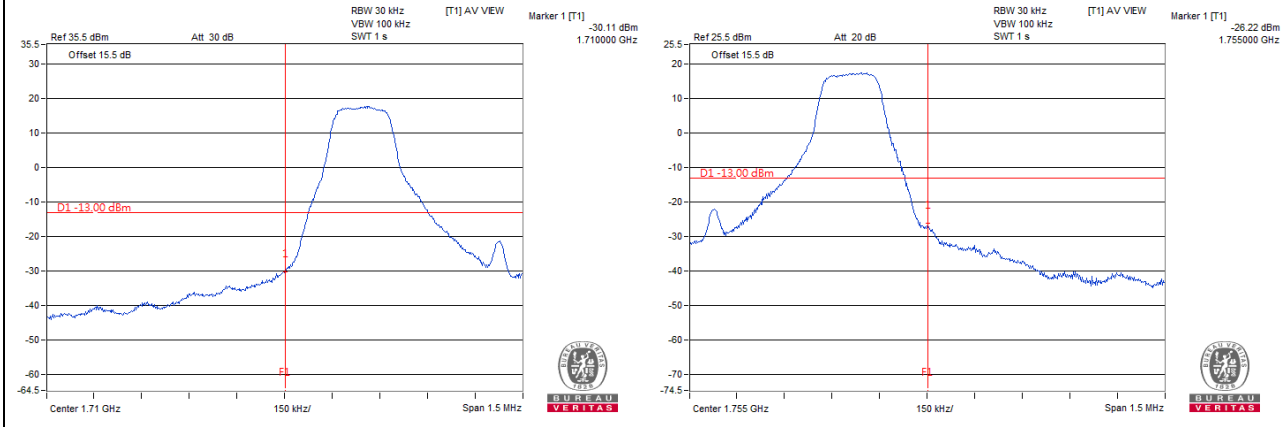

Channel 19957 (1710.7MHz)	QPSK	6 RB / 0 RB Offset	Channel 20393 (1754.3MHz)	QPSK	6 RB / 0 RB Offset
------------------------------	------	--------------------	------------------------------	------	--------------------

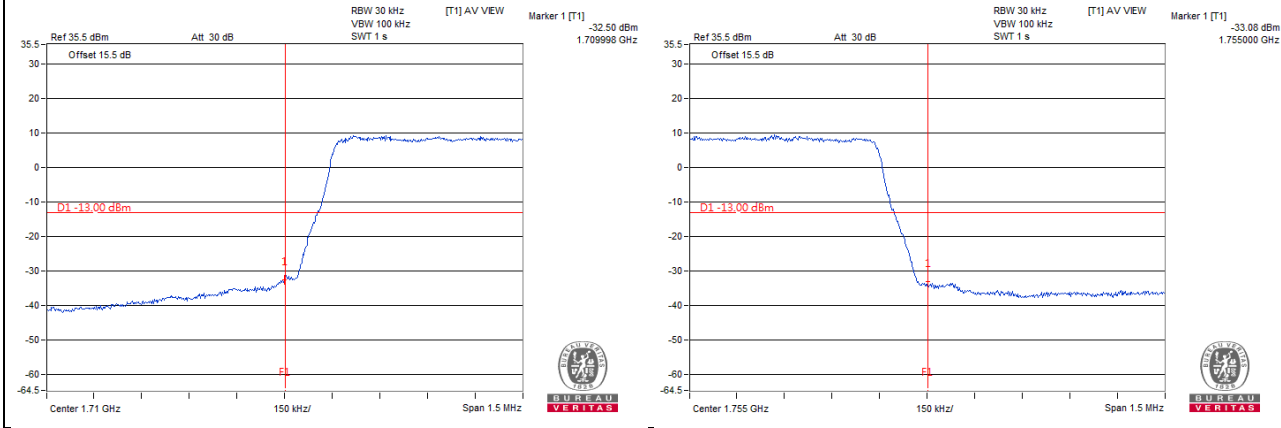

Channel Bandwidth: 3MHz

**Channel 19965
(1711.5MHz)**

QPSK

1 RB / 0 RB Offset

**Channel 20385
(1753.5MHz)**

QPSK

1 RB / 14 RB Offset

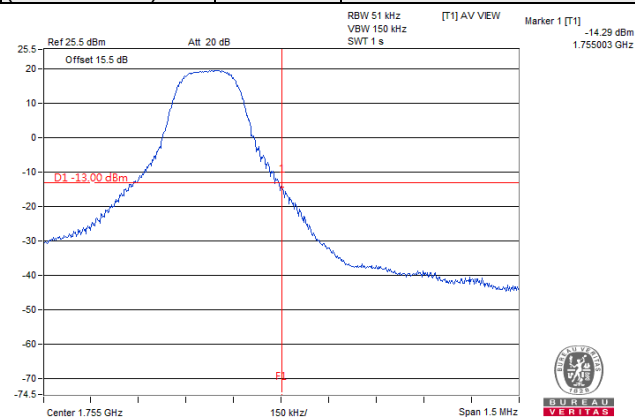
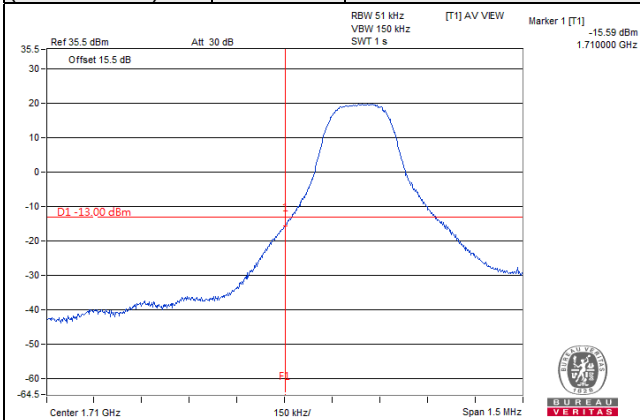

**Channel 19965
(1711.5MHz)**

QPSK

15 RB / 0 RB Offset

**Channel 20385
(1753.5MHz)**

QPSK

15 RB / 0 RB Offset

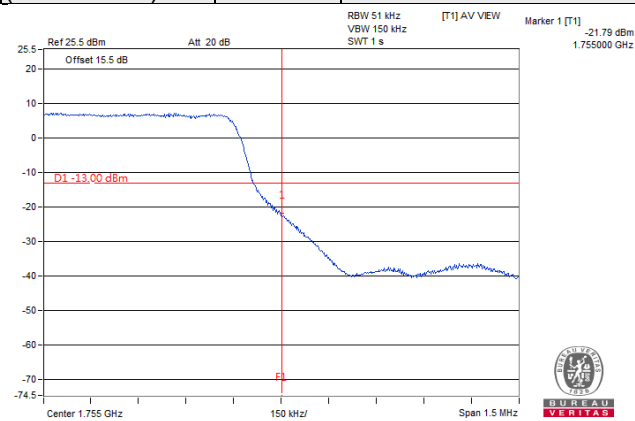
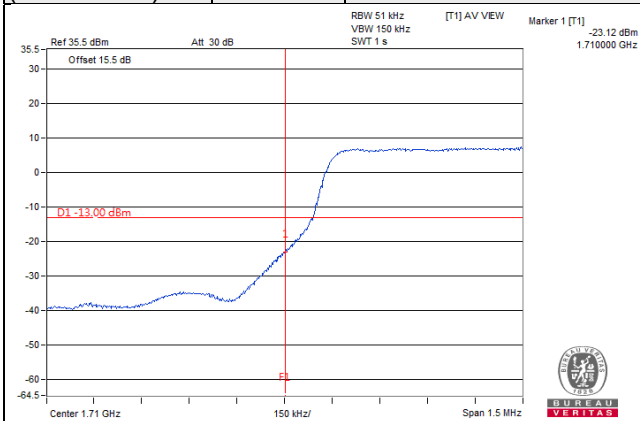

Channel Bandwidth: 5MHz

**Channel 19975
(1712.5MHz)**

QPSK

1 RB / 0 RB Offset

**Channel 20375
(1752.5MHz)**

QPSK

1 RB / 24 RB Offset

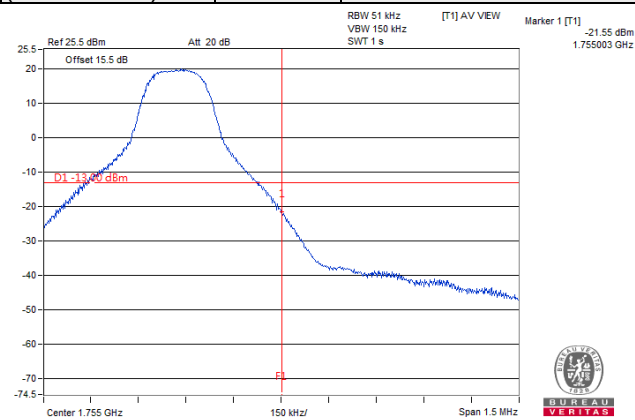
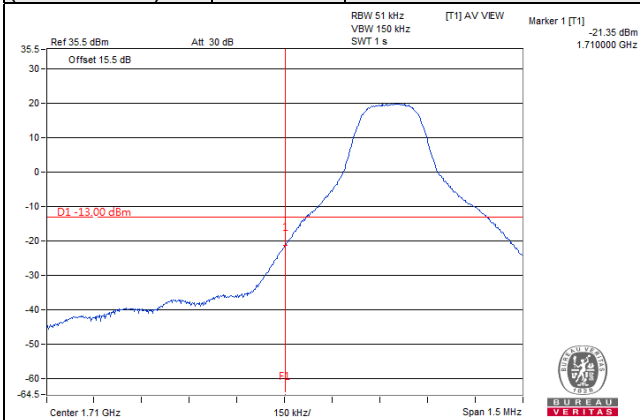

**Channel 19975
(1712.5MHz)**

QPSK

25 RB / 0 RB Offset

**Channel 20375
(1752.5MHz)**

QPSK

25 RB / 0 RB Offset

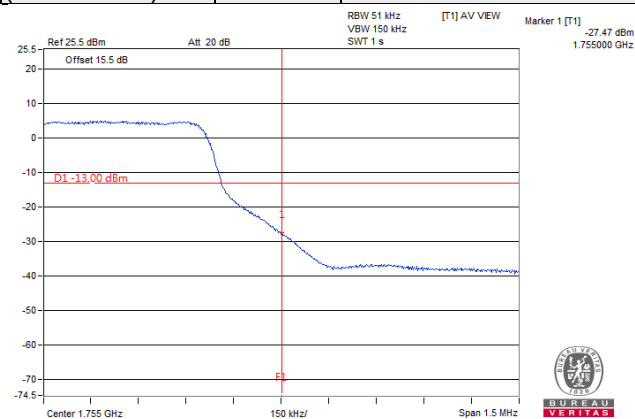
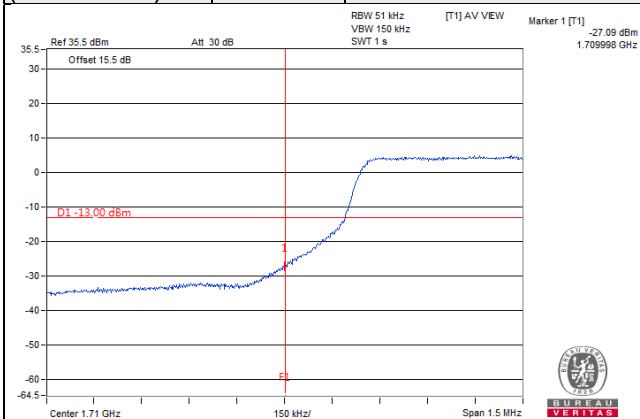

Channel Bandwidth: 10MHz

**Channel 20000
(1715.0MHz)**

QPSK

1 RB / 0 RB Offset

**Channel 20350
(1750.0MHz)**

QPSK

1 RB / 49 RB Offset

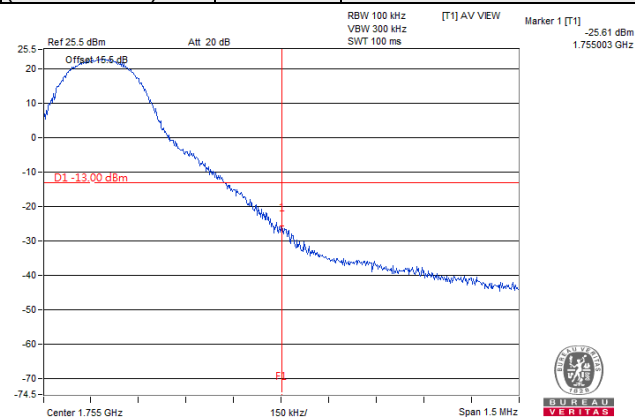
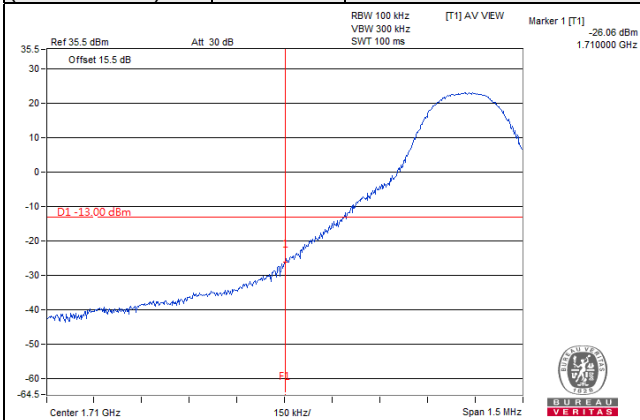

**Channel 20000
(1715.0MHz)**

QPSK

50 RB / 0 RB Offset

**Channel 20350
(1750.0MHz)**

QPSK

50 RB / 0 RB Offset

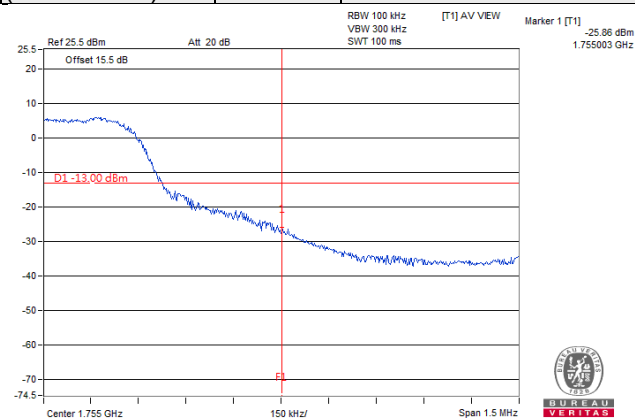
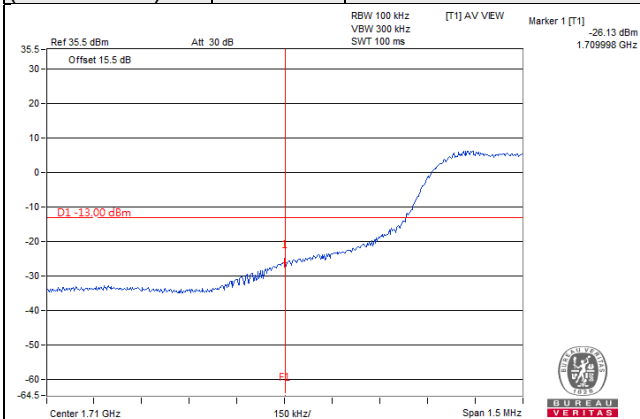

Channel Bandwidth: 15MHz

**Channel 20025
(1717.5MHz)**

QPSK

1 RB / 0 RB Offset

**Channel 20325
(1747.5MHz)**

QPSK

1 RB / 74 RB Offset

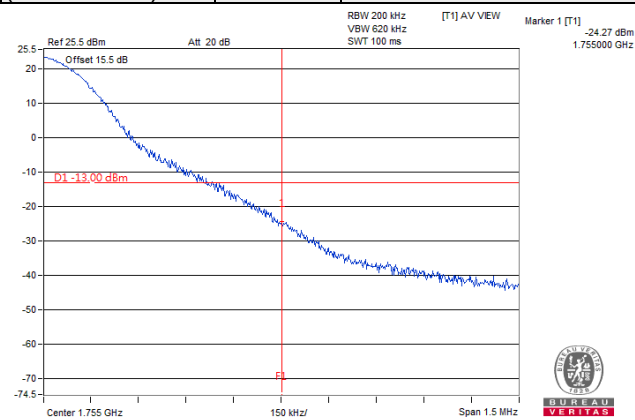
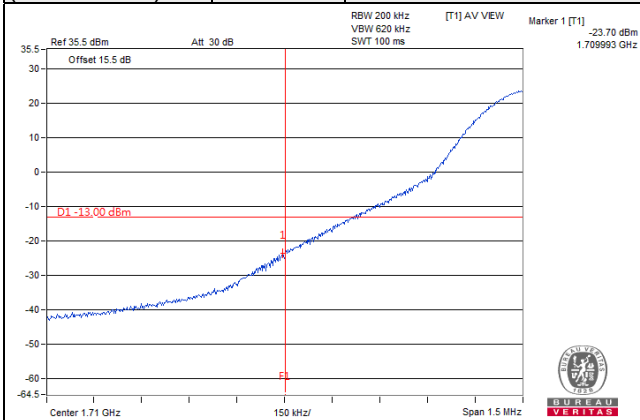

**Channel 20025
(1717.5MHz)**

QPSK

75 RB / 0 RB Offset

**Channel 20325
(1747.5MHz)**

QPSK

75 RB / 0 RB Offset

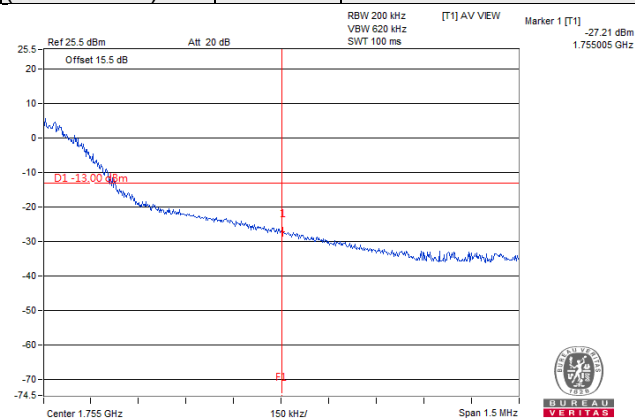
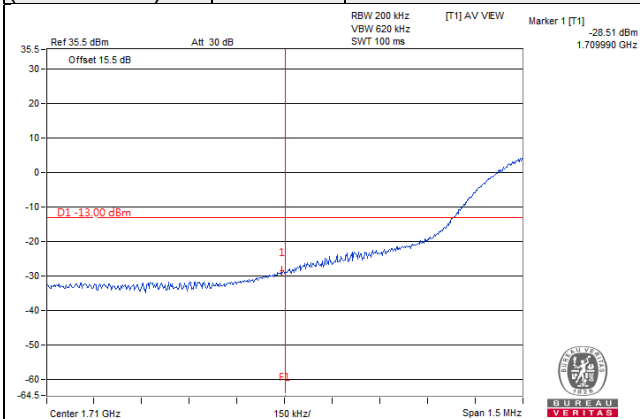

Channel Bandwidth: 20MHz

**Channel 20050
(1720.0MHz)**

QPSK

1 RB / 0 RB Offset

**Channel 20300
(1745.0MHz)**

QPSK

1 RB / 99 RB Offset

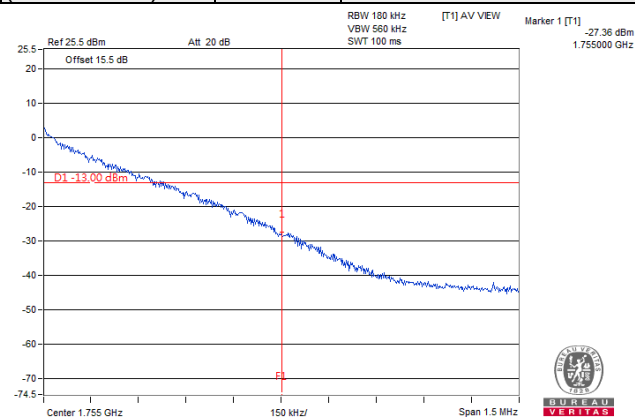
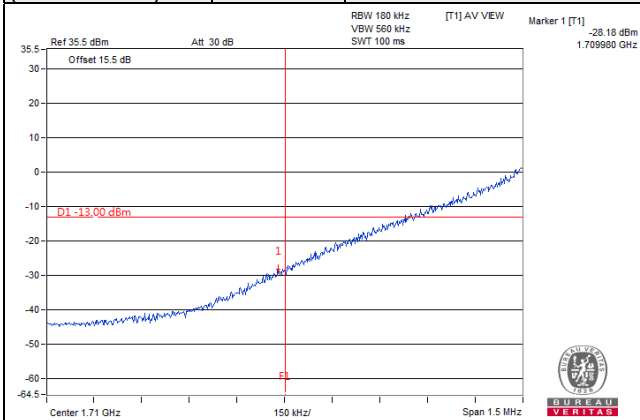

**Channel 20050
(1720.0MHz)**

QPSK

100 RB / 0 RB Offset

**Channel 20300
(1745.0MHz)**

QPSK

100 RB / 0 RB Offset

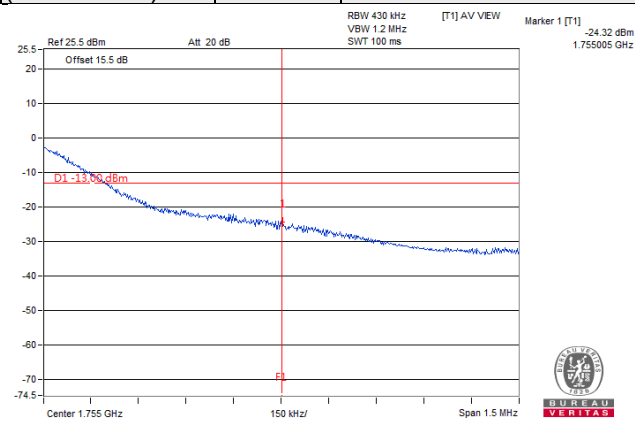
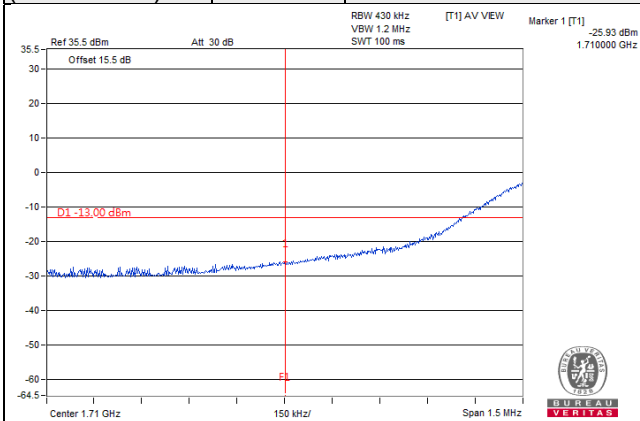

LTE Band 7

Channel Bandwidth: 5MHz

Channel 20775 (2502.5MHz)	QPSK	1 RB / 0 RB Offset	Channel 21425 (2567.5MHz)	QPSK	1 RB / 24 RB Offset
------------------------------	------	--------------------	------------------------------	------	---------------------

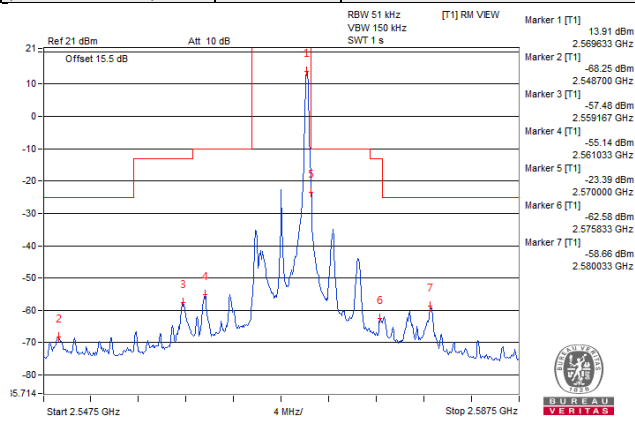
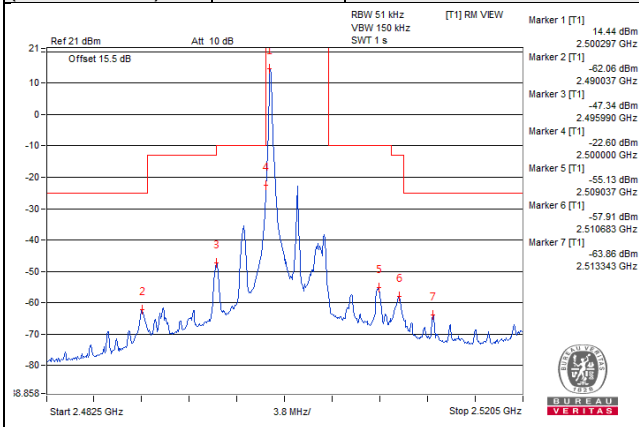

Channel 20775 (2502.5MHz)	QPSK	25 RB / 0 RB Offset	Channel 21425 (2567.5MHz)	QPSK	25 RB / 0 RB Offset
------------------------------	------	---------------------	------------------------------	------	---------------------

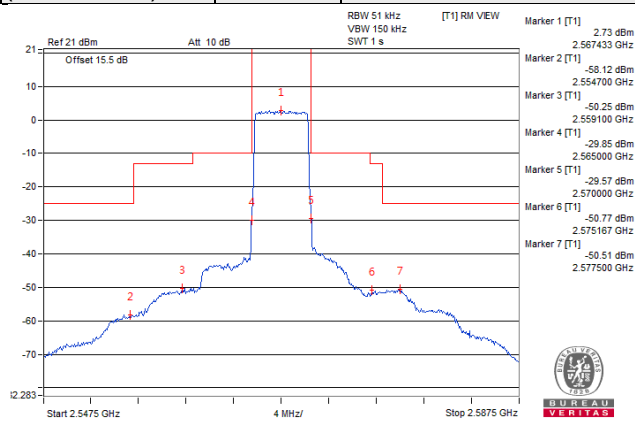
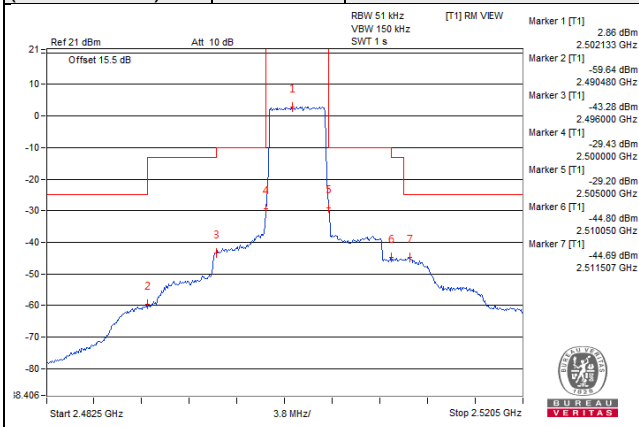

Channel Bandwidth: 10MHz

Channel 20800 (2505MHz)	QPSK	1 RB / 0 RB Offset	Channel 21400 (2565MHz)	QPSK	1 RB / 49RB Offset
--------------------------------	-------------	---------------------------	--------------------------------	-------------	---------------------------

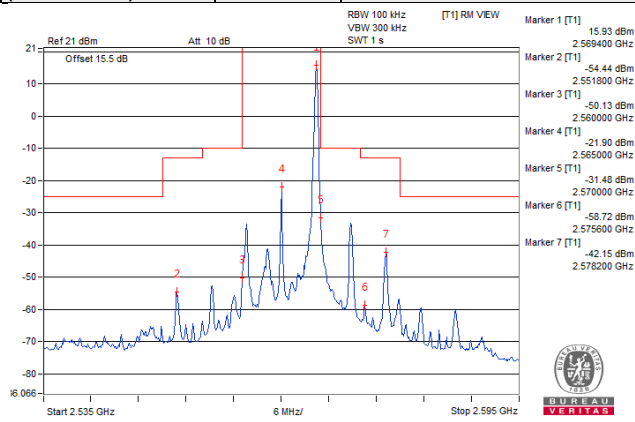
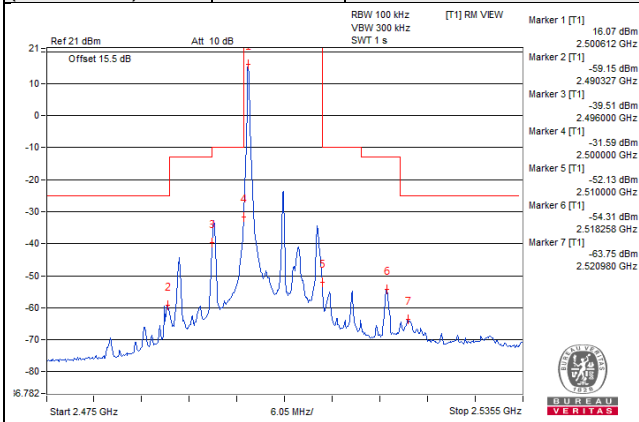

Channel 20800 (2505MHz)	QPSK	50 RB / 0 RB Offset	Channel 21400 (2565MHz)	QPSK	50 RB / 0 RB Offset
--------------------------------	-------------	----------------------------	--------------------------------	-------------	----------------------------

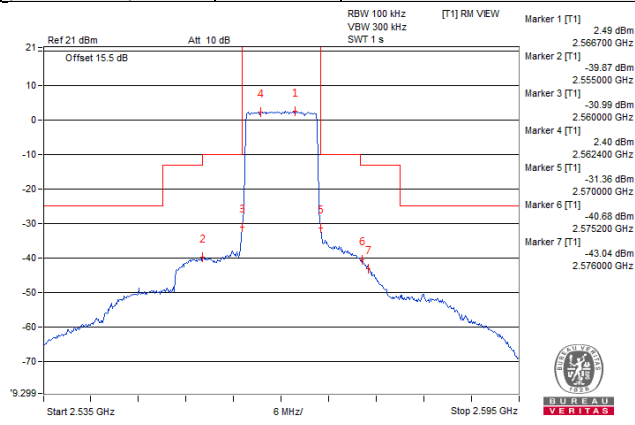
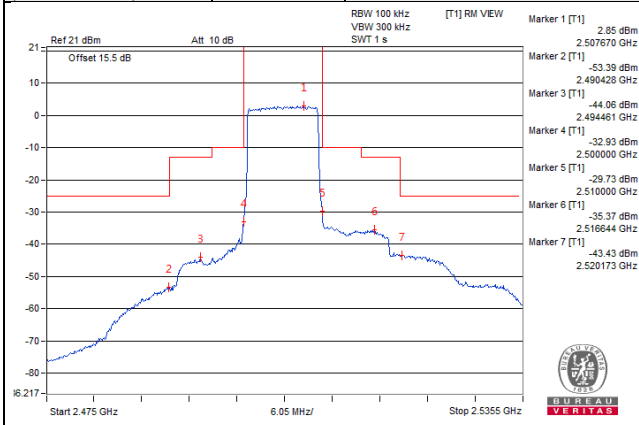

Channel Bandwidth: 15MHz

Channel 20825 (2507.5MHz)	QPSK	1 RB / 0 RB Offset	Channel 21375 (2562.5MHz)	QPSK	1 RB / 74RB Offset
--------------------------------------	-------------	---------------------------	--------------------------------------	-------------	---------------------------

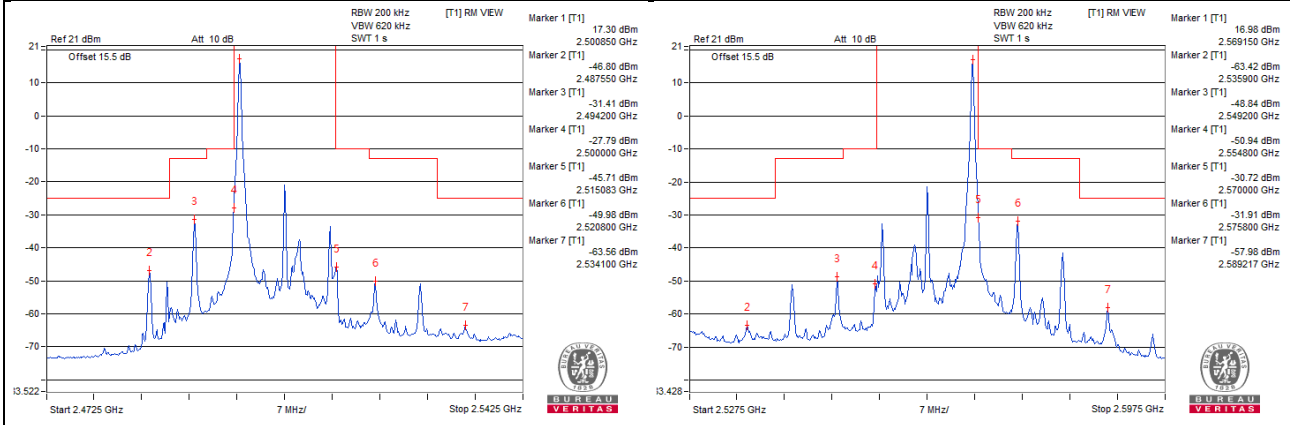

Channel 20825 (2507.5MHz)	QPSK	75 RB / 0 RB Offset	Channel 21375 (2562.5MHz)	QPSK	75 RB / 0 RB Offset
--------------------------------------	-------------	----------------------------	--------------------------------------	-------------	----------------------------

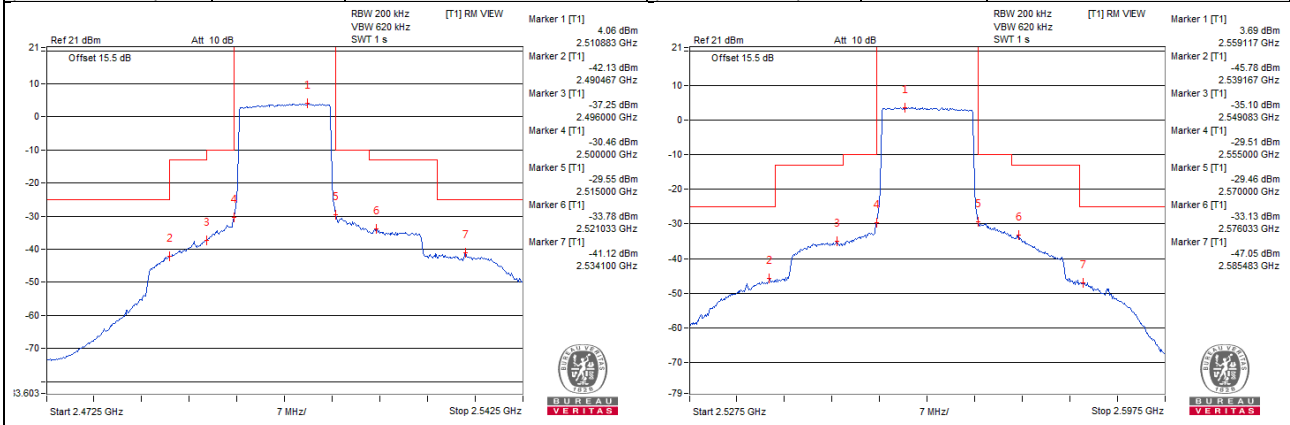

Channel Bandwidth: 20MHz

Channel 20850
(2510MHz)

QPSK

1 RB / 0 RB Offset

Channel 21350
(2560MHz)

QPSK

1 RB / 99RB Offset

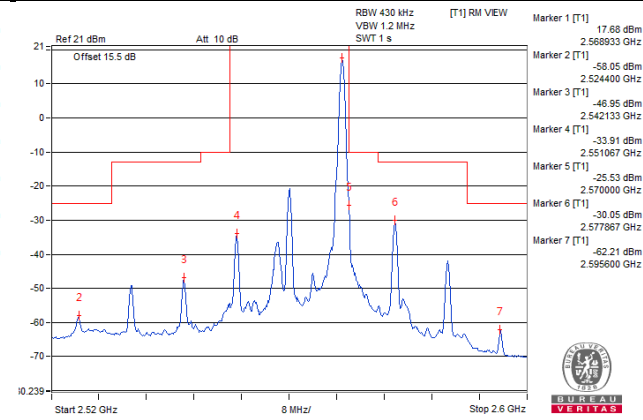
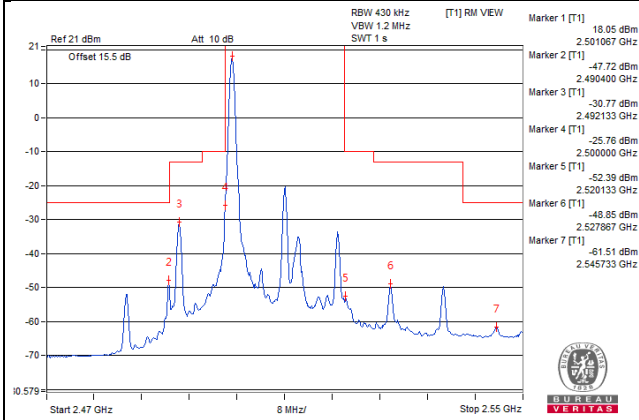

Channel 20850
(2510MHz)

QPSK

100 RB / 0 RB Offset

Channel 21350
(2560MHz)

QPSK

100 RB / 0 RB Offset

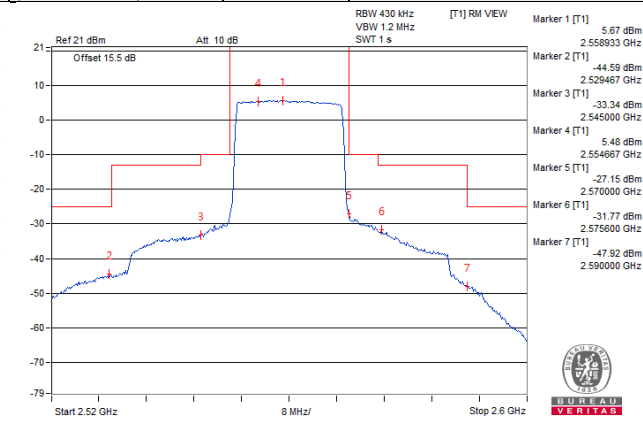
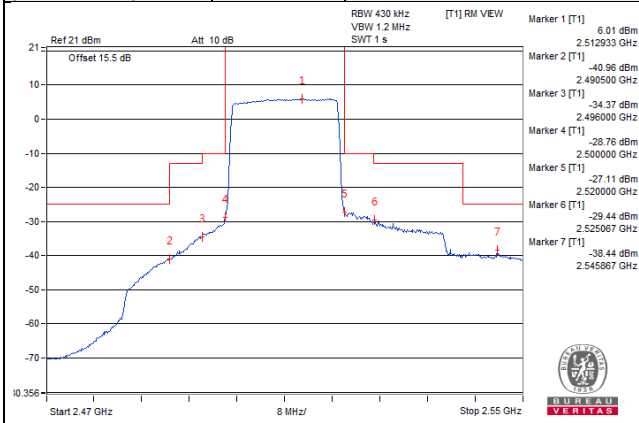

LTE Band 7
CA Mode

Channel Bandwidth: 20MHz+20MHz

Ch. 20850(2510.0MHz)+ Ch. 21048(2529.8MHz)	QPSK	1 RB / 0 RB Offset	Ch. 21350(2560.0MHz)+ Ch. 21152(2540.2MHz)	QPSK	1 RB / 0 RB Offset
---	------	--------------------	---	------	--------------------

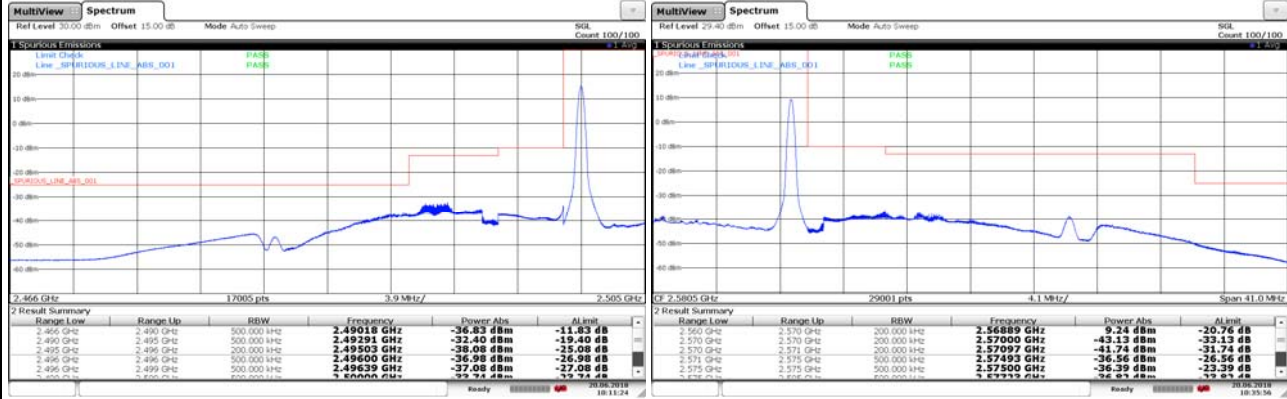

Ch. 20850(2510.0MHz)+ Ch. 21048(2529.8MHz)	QPSK	100 RB / 0 RB Offset	Ch. 21350(2560.0MHz) + Ch. 21152(2540.2MHz)	QPSK	100 RB / 0 RB Offset
---	------	----------------------	--	------	----------------------

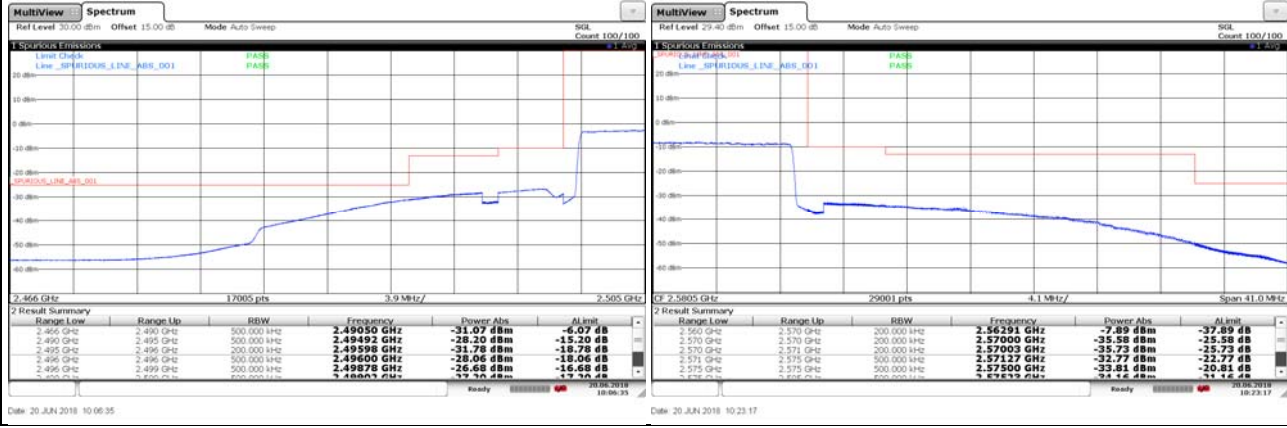

LTE Band 12

Channel Bandwidth: 1.4MHz

Channel 23017 (699.7MHz)	QPSK	1 RB / 0 RB Offset	Channel 23171 (715.3MHz)	QPSK	1 RB / 5 RB Offset
-----------------------------	------	--------------------	-----------------------------	------	--------------------

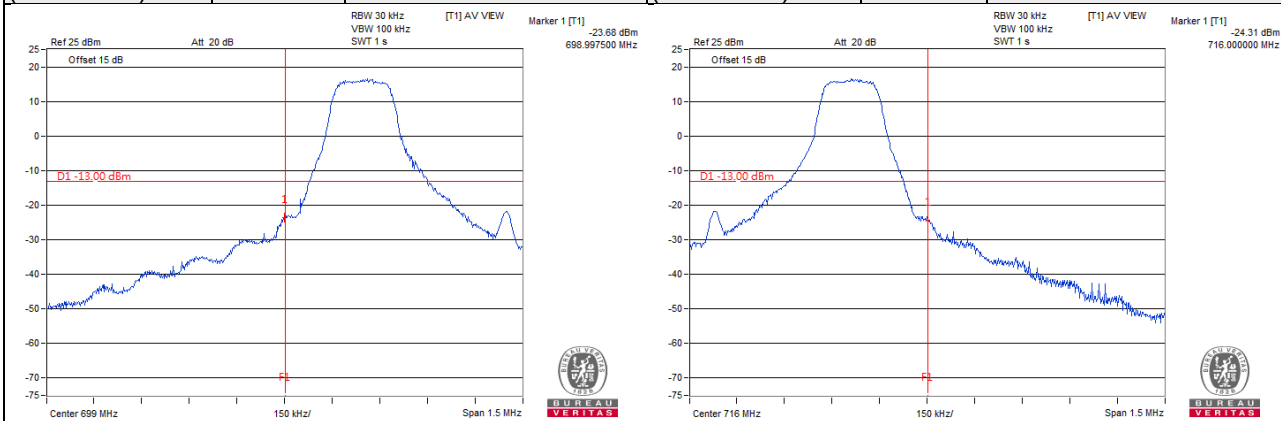

Channel 23017 (699.7MHz)	QPSK	6 RB / 0 RB Offset	Channel 23171 (715.3MHz)	QPSK	6 RB / 0 RB Offset
-----------------------------	------	--------------------	-----------------------------	------	--------------------

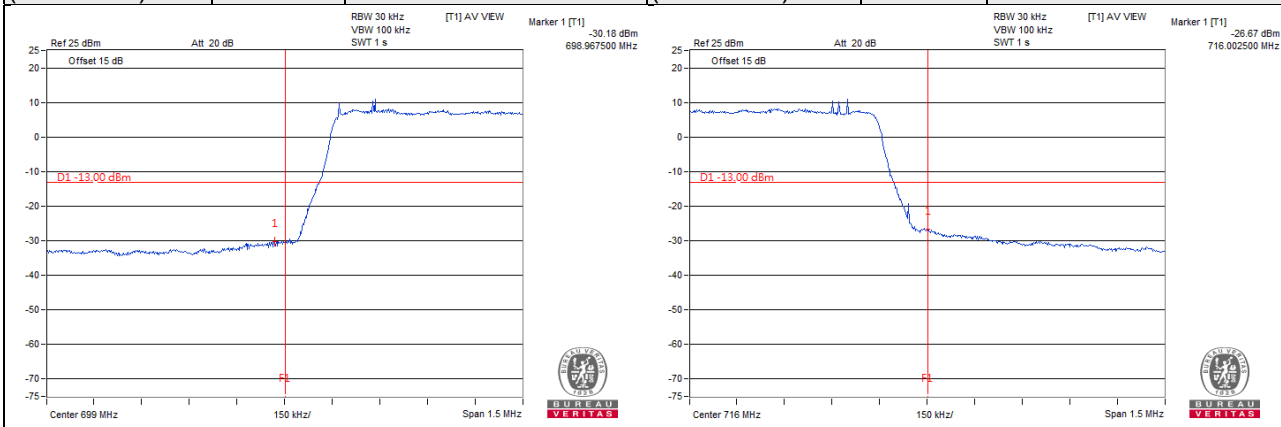

Channel Bandwidth: 3MHz

**Channel 23025
(700.5MHz)**

QPSK

1 RB / 0 RB Offset

**Channel 23165
(714.5MHz)**

QPSK

1 RB / 14RB Offset

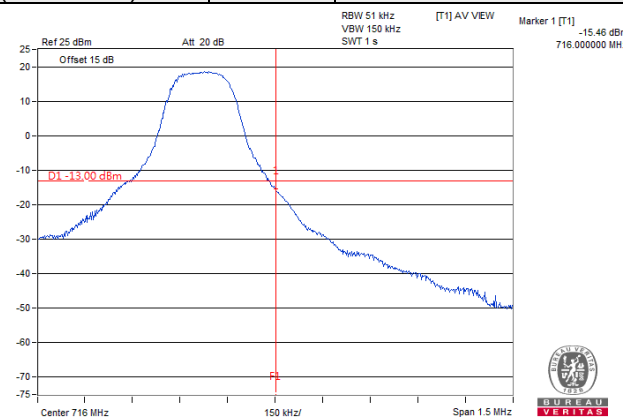
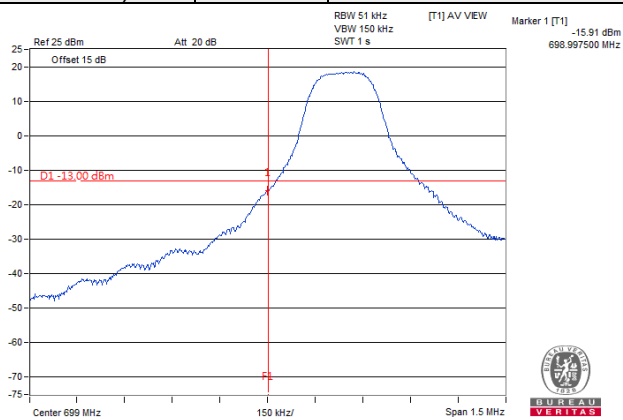

**Channel 23025
(700.5MHz)**

QPSK

15 RB / 0 RB Offset

**Channel 23165
(714.5MHz)**

QPSK

15 RB / 0 RB Offset

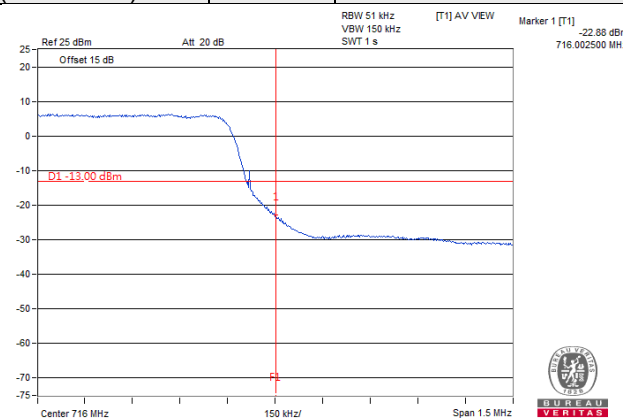
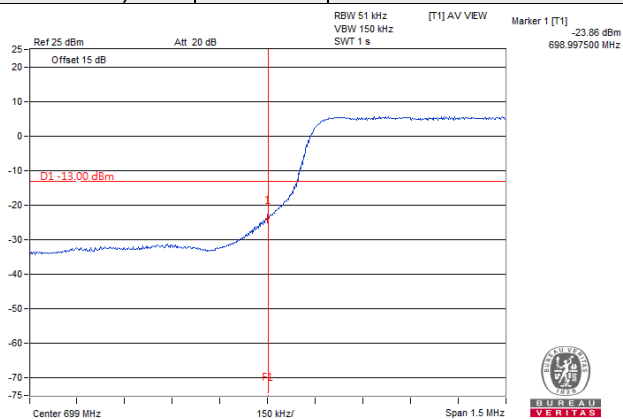

Channel Bandwidth: 5MHz

**Channel 23035
(701.5MHz)**

QPSK

1 RB / 0 RB Offset

**Channel 23155
(713.5MHz)**

QPSK

1 RB / 24RB Offset

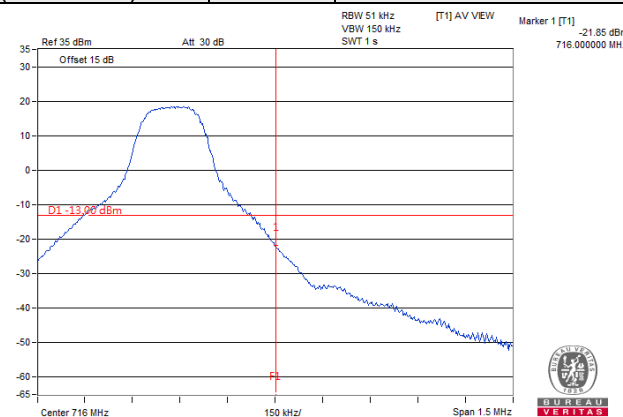
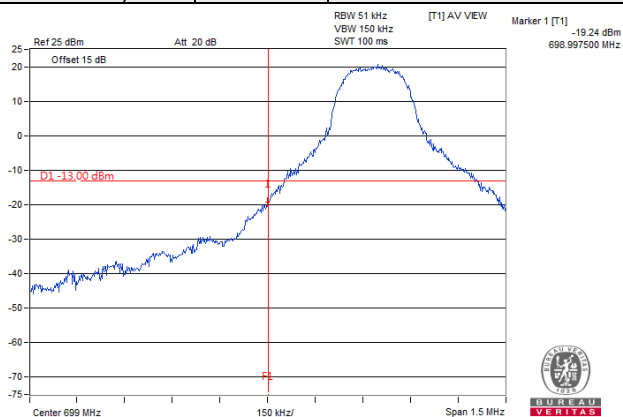

**Channel 23035
(701.5MHz)**

QPSK

25 RB / 0 RB Offset

**Channel 23155
(713.5MHz)**

QPSK

25 RB / 0 RB Offset

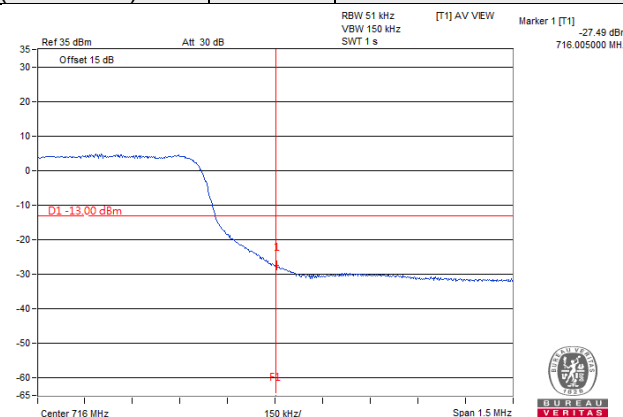
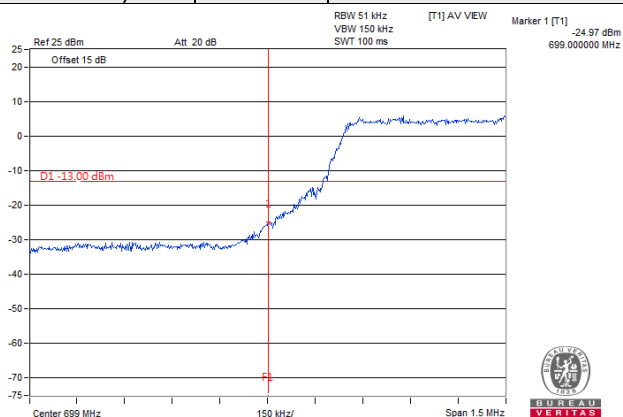

Channel Bandwidth: 10MHz

**Channel 23060
(704MHz)**

QPSK

1 RB / 0 RB Offset

**Channel 23130
(711MHz)**

QPSK

1 RB / 24RB Offset

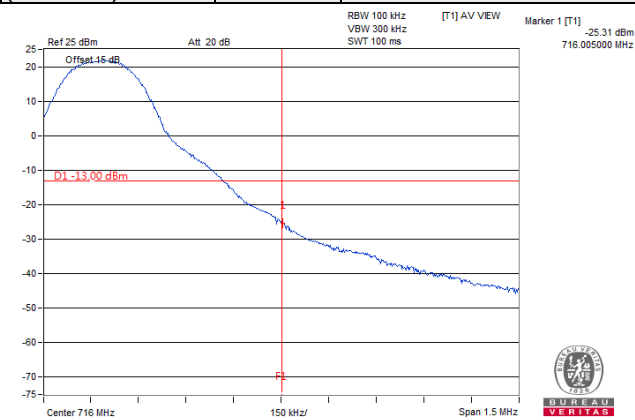
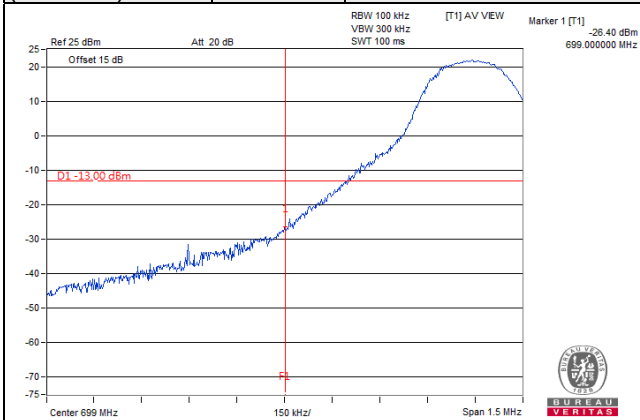

**Channel 23060
(704MHz)**

QPSK

50 RB / 0 RB Offset

**Channel 23130
(711MHz)**

QPSK

25 RB / 0 RB Offset

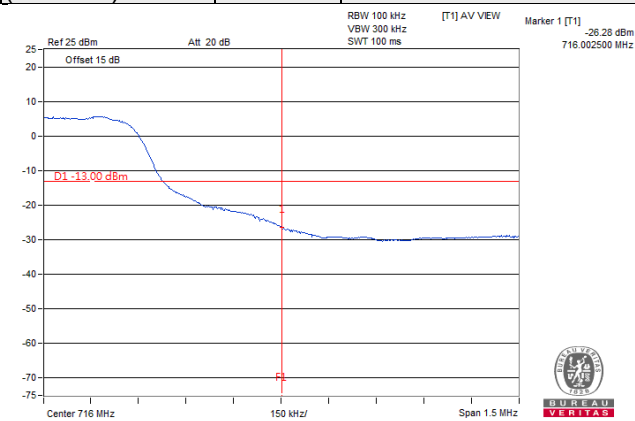
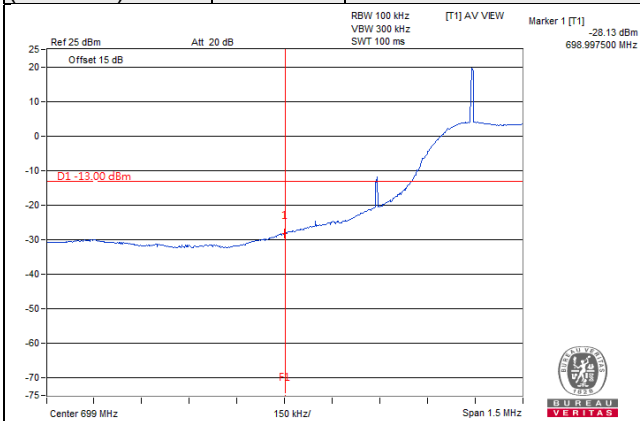

LTE Band 13

Channel Bandwidth: 5MHz

Channel 23205 (779.5MHz)	QPSK	1 RB / 0 RB Offset	Channel 23255 (784.5MHz)	QPSK	1 RB / 24 RB Offset
-----------------------------	------	--------------------	-----------------------------	------	---------------------

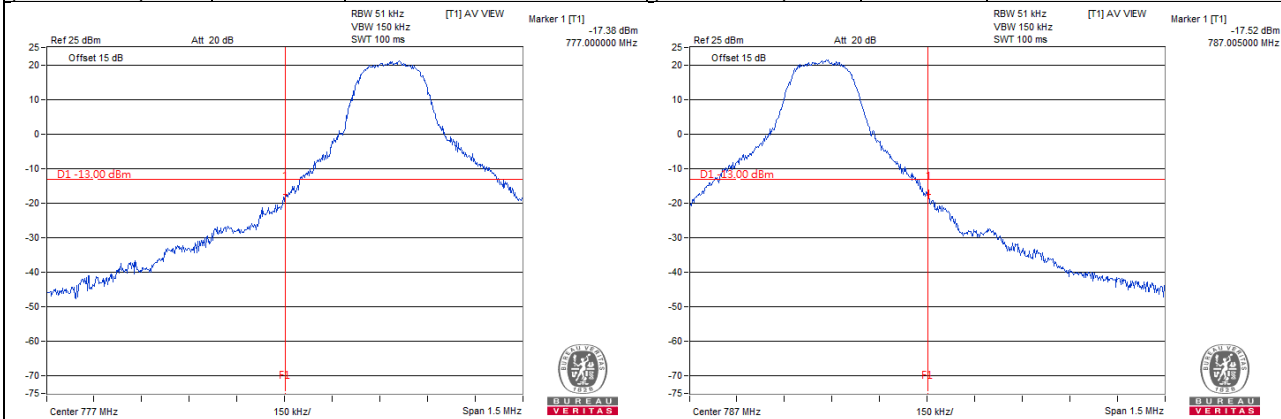

Channel 23205 (779.5MHz)	QPSK	25 RB / 0 RB Offset	Channel 23255 (784.5MHz)	QPSK	25 RB / 0 RB Offset
-----------------------------	------	---------------------	-----------------------------	------	---------------------

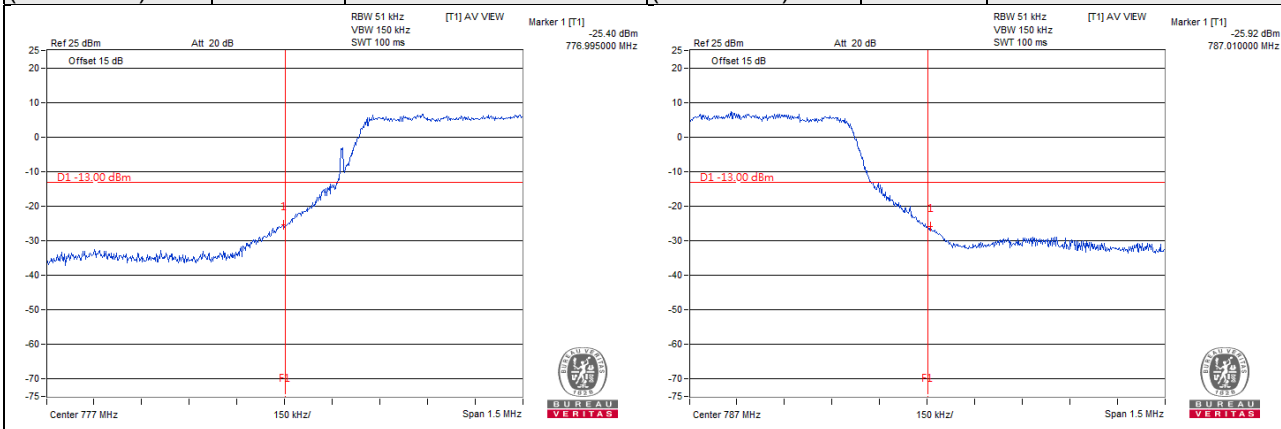

Channel Bandwidth: 10MHz

Channel 23230 (782.0MHz)	QPSK	1 RB / 0 RB Offset	Channel 23230 (782.0MHz)	QPSK	1 RB / 49 RB Offset
-----------------------------	------	--------------------	-----------------------------	------	---------------------

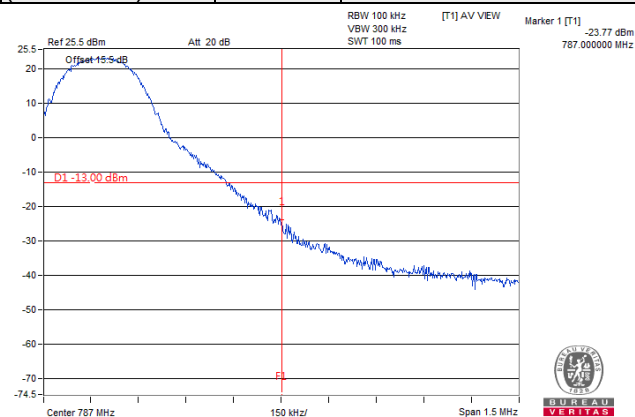
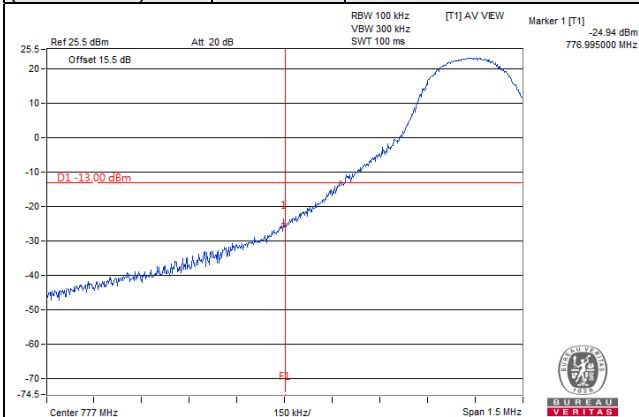

Channel 23230 (782.0MHz)	QPSK	50 RB / 0 RB Offset	Channel 23230 (782.0MHz)	QPSK	50 RB / 0 RB Offset
-----------------------------	------	---------------------	-----------------------------	------	---------------------

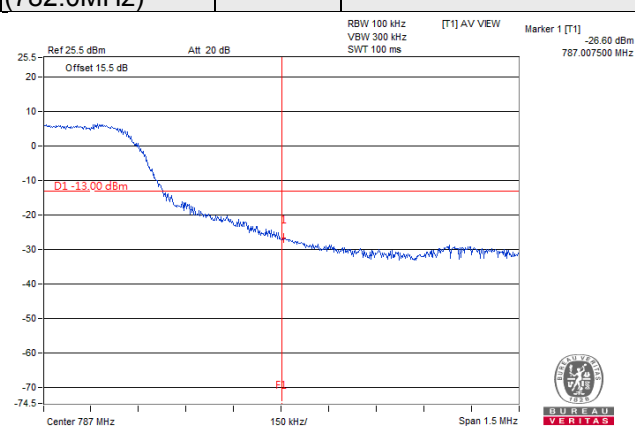
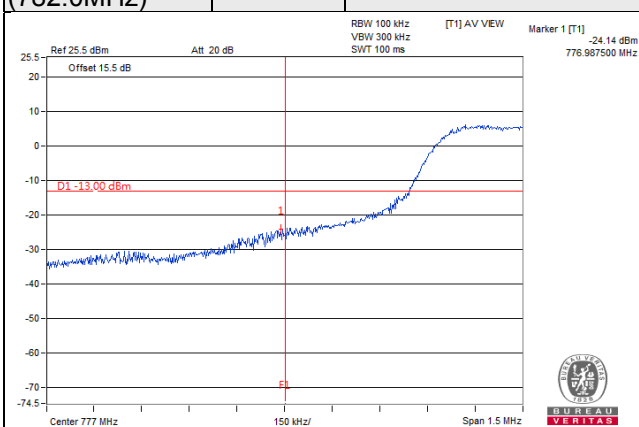

LTE Band 13

Channel Bandwidth: 5MHz

Channel 23205 (779.5MHz)	QPSK	1 RB / 0 RB Offset	Channel 23255 (784.5MHz)	QPSK	1 RB / 24 RB Offset
-----------------------------	------	--------------------	-----------------------------	------	---------------------

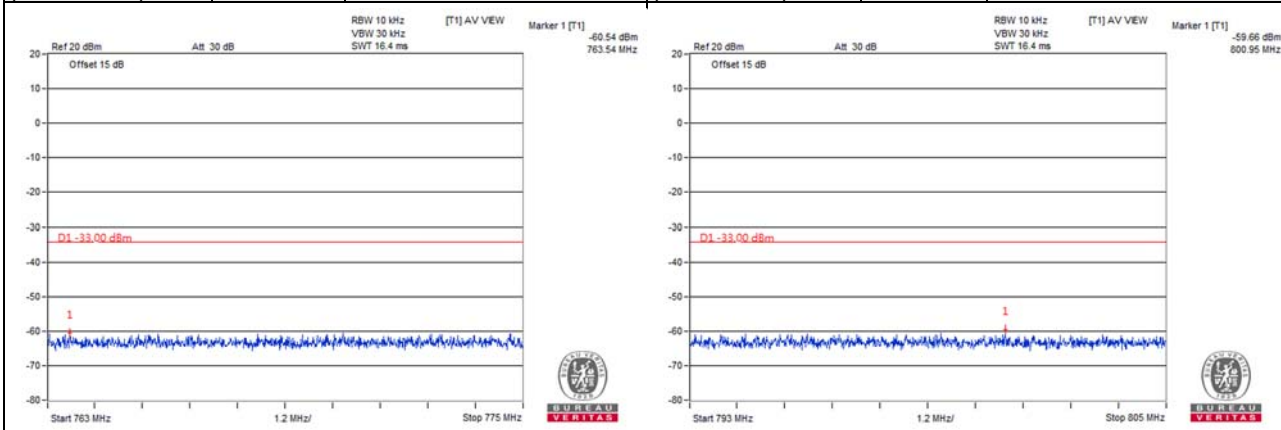

Channel 23205 (779.5MHz)	QPSK	25 RB / 0 RB Offset	Channel 23255 (784.5MHz)	QPSK	25 RB / 0 RB Offset
-----------------------------	------	---------------------	-----------------------------	------	---------------------

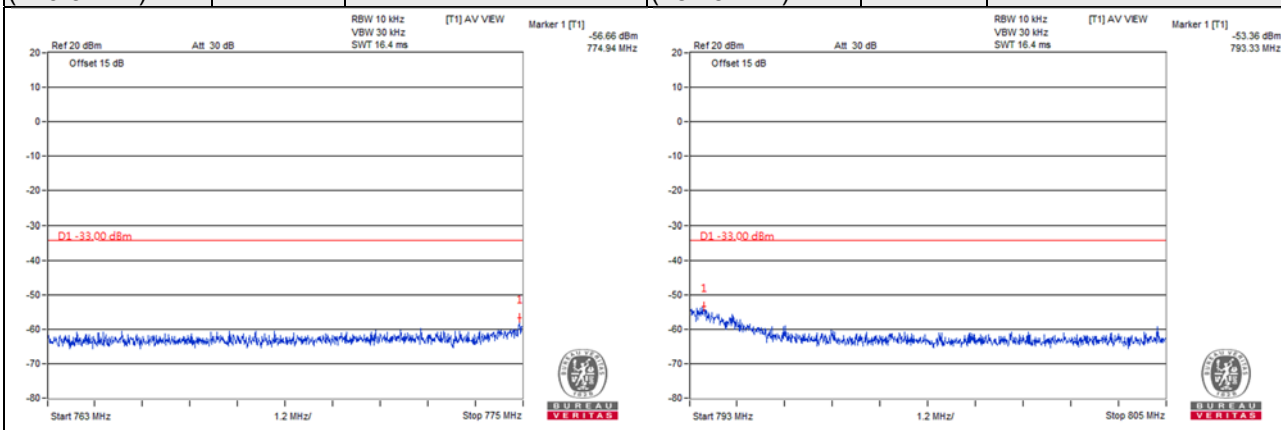

For the 763 - 775 MHz and 793 - 805 MHz band, the FCC limit is $65 + 10\log(P[\text{watt}])$ in a 6.25 kHz bandwidth. Since it was not possible to set the resolution bandwidth to 6.25 kHz with the available equipment, a bandwidth of 10 kHz was used instead to show compliance. By using a 10 kHz bandwidth on the spectrum analyzer.

$$10\log(10\text{kHz}/6.25\text{kHz}) = 2.04 \text{ dB}$$

$$\text{Limit line} = -35 \text{ dBm} + 2.04 \text{ dB} = -32.96 \text{ dBm}$$

Channel Bandwidth: 10MHz

Channel 23230(782.0MHz)	QPSK	1 RB / 0 RB Offset	Channel 23230(782.0MHz)	QPSK	1 RB / 49 RB Offset
----------------------------	------	--------------------	----------------------------	------	---------------------

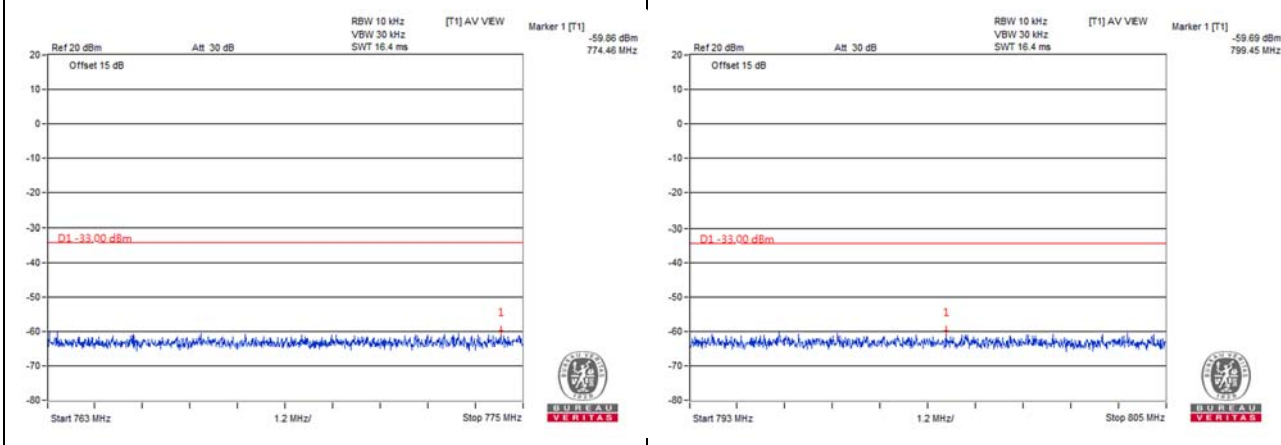

Channel 23230(782.0MHz)	QPSK	50 RB / 0 RB Offset	Channel 23230(782.0MHz)	QPSK	50 RB / 0 RB Offset
----------------------------	------	---------------------	----------------------------	------	---------------------

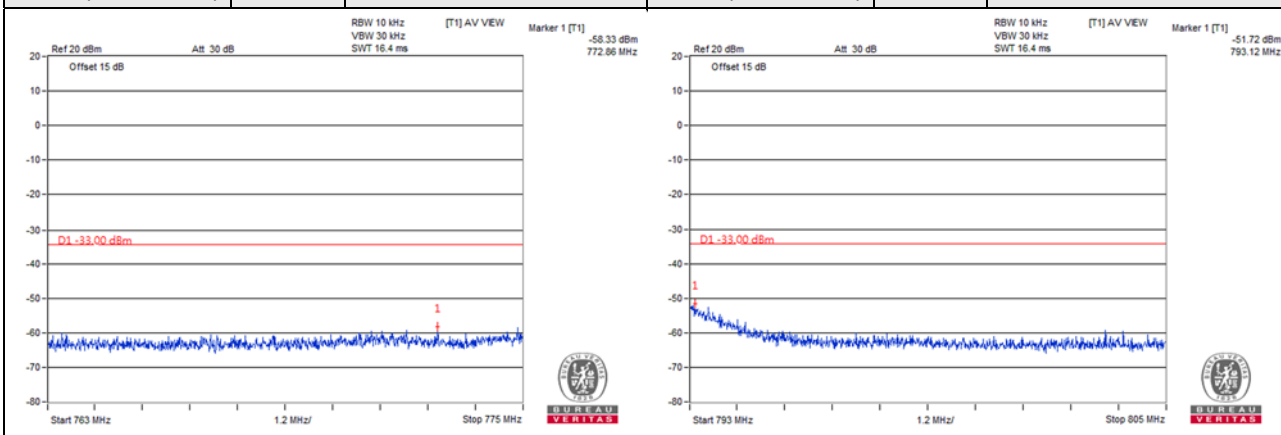

For the 763 - 775 MHz and 793 - 805 MHz band, the FCC limit is $65 + 10 \log(P[\text{watt}])$ in a 6.25 kHz bandwidth. Since it was not possible to set the resolution bandwidth to 6.25 kHz with the available equipment, a bandwidth of 10 kHz was used instead to show compliance. By using a 10 kHz bandwidth on the spectrum analyzer.

$$10 \log(10\text{kHz}/6.25\text{kHz}) = 2.04 \text{ dB}$$

$$\text{Limit line} = -35 \text{ dBm} + 2.04 \text{ dB} = -32.96 \text{ dBm}$$

LTE Band 17

Channel Bandwidth: 5MHz

Channel 23755 (706.5MHz)	QPSK	1 RB / 0 RB Offset	Channel 23825 (713.5MHz)	QPSK	1 RB / 24 RB Offset
-----------------------------	------	--------------------	-----------------------------	------	---------------------

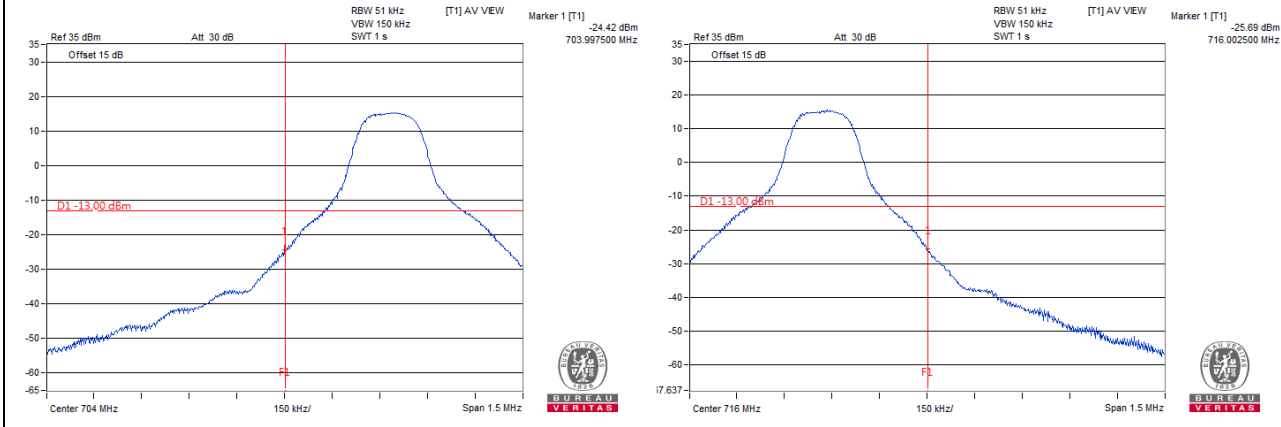

Channel 23755 (706.5MHz)	QPSK	25 RB / 0 RB Offset	Channel 23825 (713.5MHz)	QPSK	25 RB / 0 RB Offset
-----------------------------	------	---------------------	-----------------------------	------	---------------------

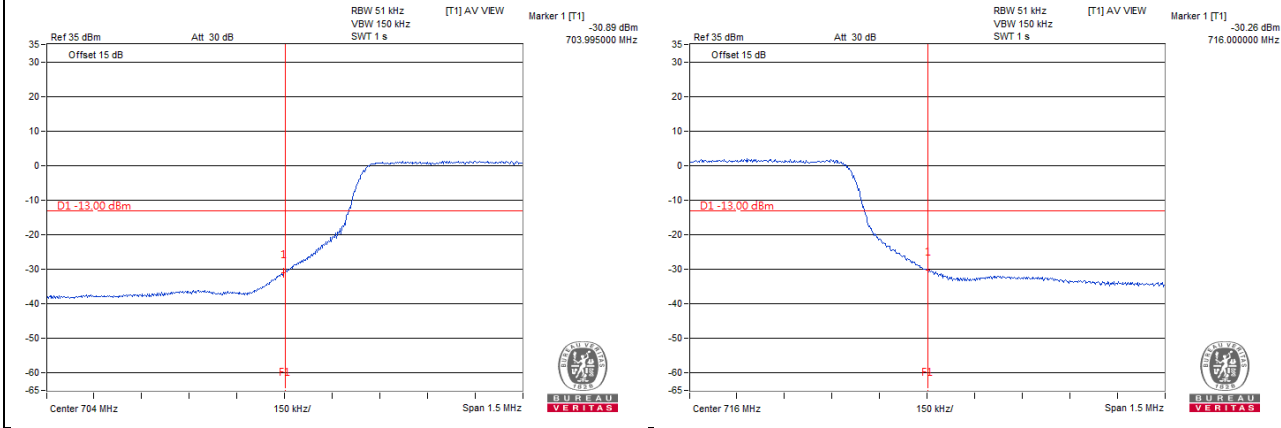

Channel Bandwidth: 10MHz

Channel 23780 (709.0MHz)	QPSK	1 RB / 0 RB Offset	Channel 23790 (711.0MHz)	QPSK	1 RB / 49 RB Offset
-------------------------------------	-------------	---------------------------	-------------------------------------	-------------	----------------------------

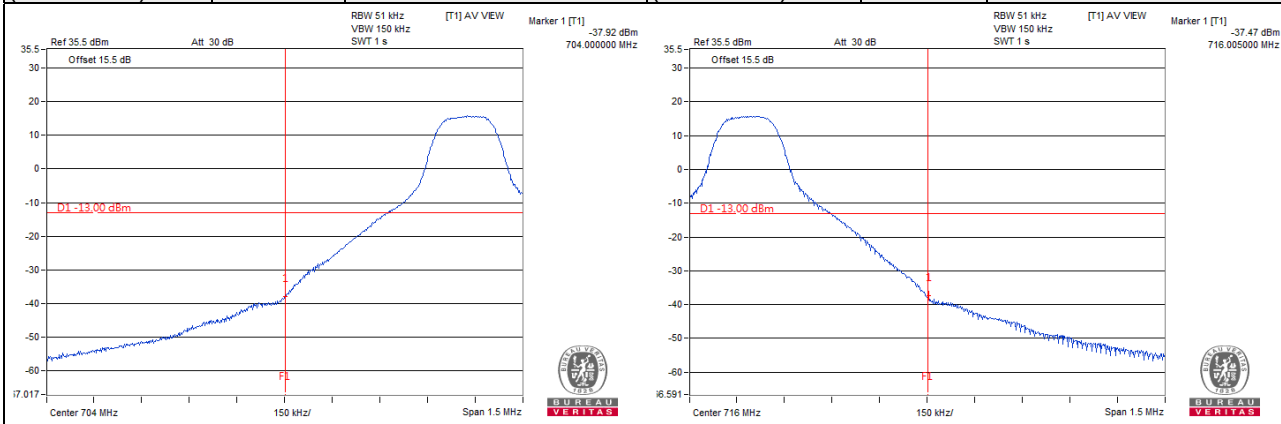

Channel 23780 (709.0MHz)	QPSK	50 RB / 0 RB Offset	Channel 23790 (711.0MHz)	QPSK	50 RB / 0 RB Offset
-------------------------------------	-------------	----------------------------	-------------------------------------	-------------	----------------------------

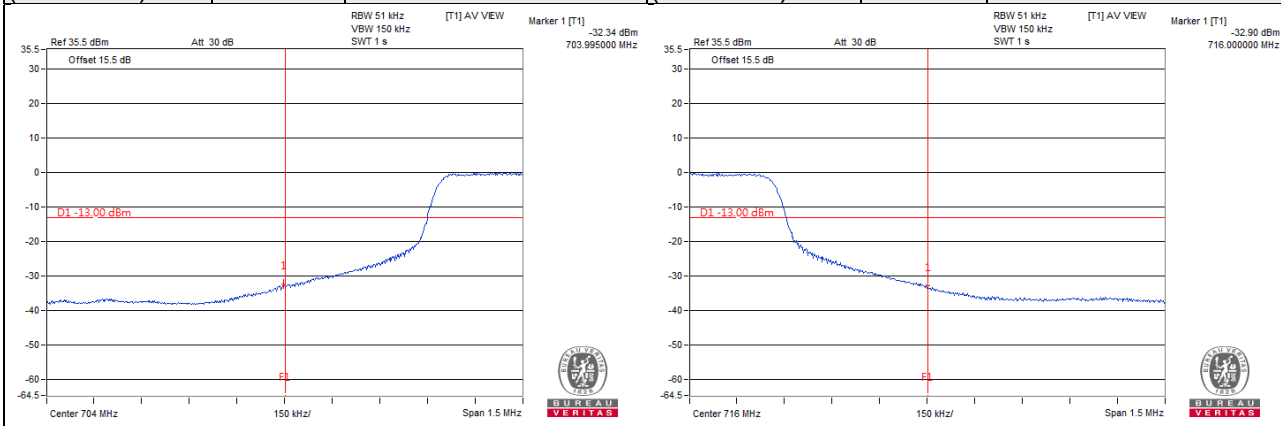

LTE Band 38

Channel Bandwidth: 5MHz_Edge

Channel 37775 (2572.5MHz)	QPSK	1 RB / 0 RB Offset	Channel 38225 (2617.5MHz)	QPSK	1 RB / 24 RB Offset
------------------------------	------	--------------------	------------------------------	------	---------------------

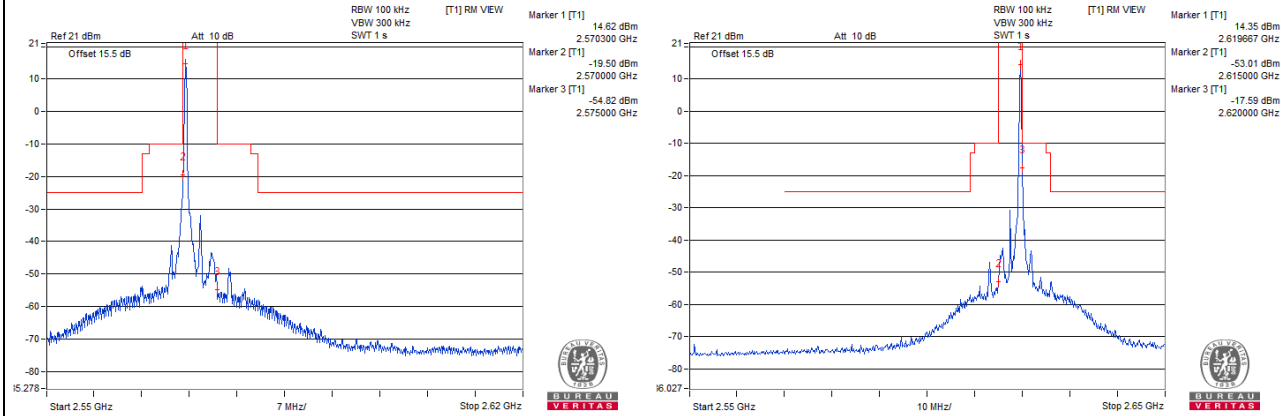

Channel 37775 (2572.5MHz)	QPSK	25 RB / 0 RB Offset	Channel 38225 (2617.5MHz)	QPSK	25 RB / 0 RB Offset
------------------------------	------	---------------------	------------------------------	------	---------------------

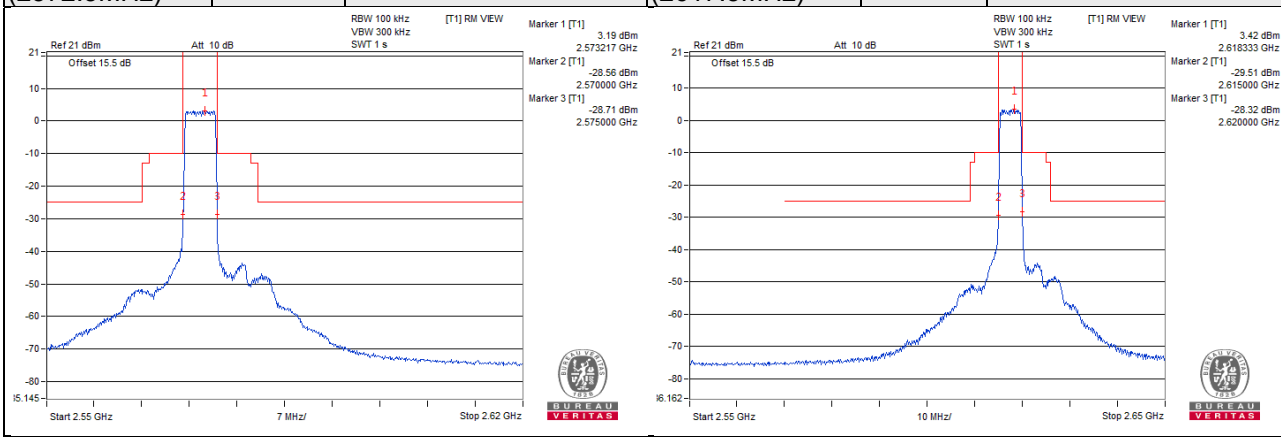

Channel Bandwidth: 5MHz_Left

Channel 37775
(2572.5MHz)

QPSK

1 RB / 0 RB Offset

Channel 38225
(2617.5MHz)

QPSK

1 RB / 24 RB Offset

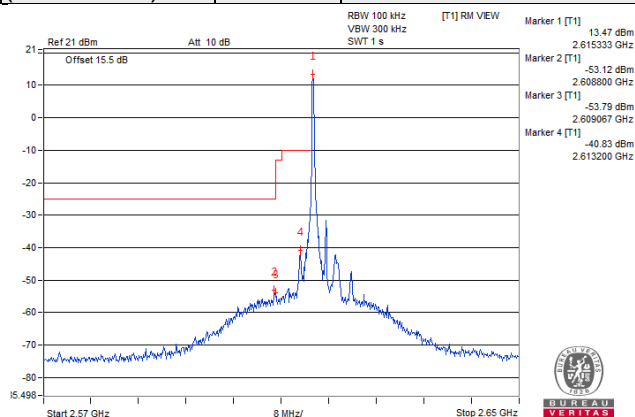
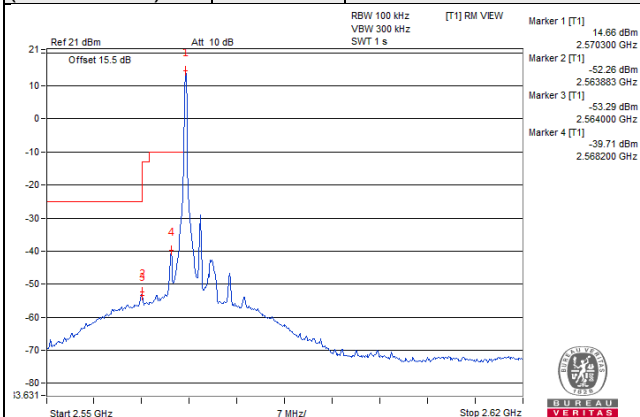

Channel 37775
(2572.5MHz)

QPSK

25 RB / 0 RB Offset

Channel 38225
(2617.5MHz)

QPSK

25 RB / 0 RB Offset

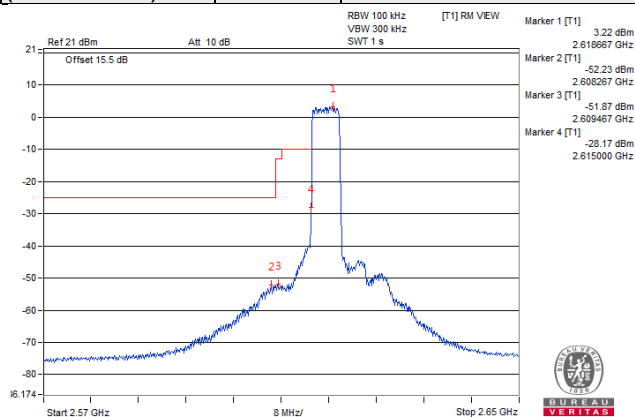
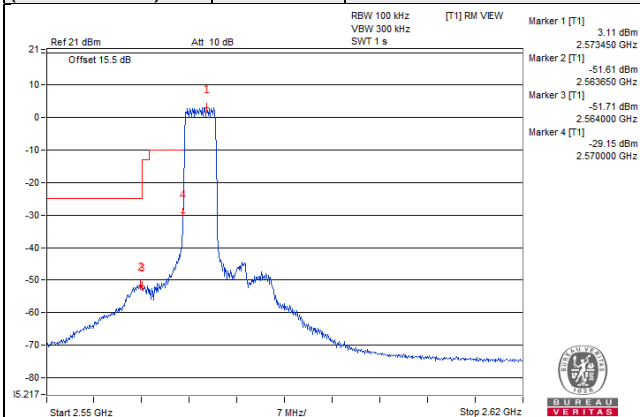

Channel Bandwidth: 5MHz_Right

Channel 37775
(2572.5MHz)

QPSK

1 RB / 0 RB Offset

Channel 38225
(2617.5MHz)

QPSK

1 RB / 24 RB Offset

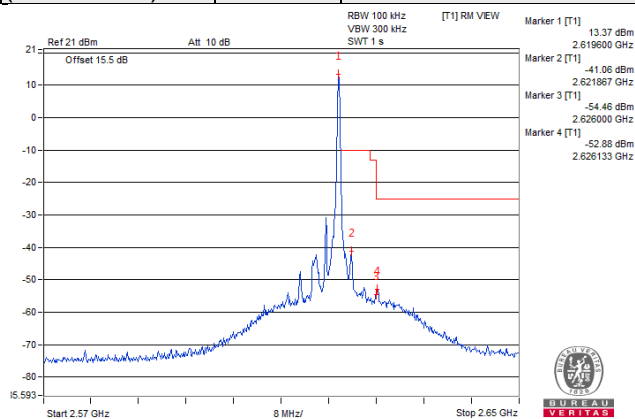
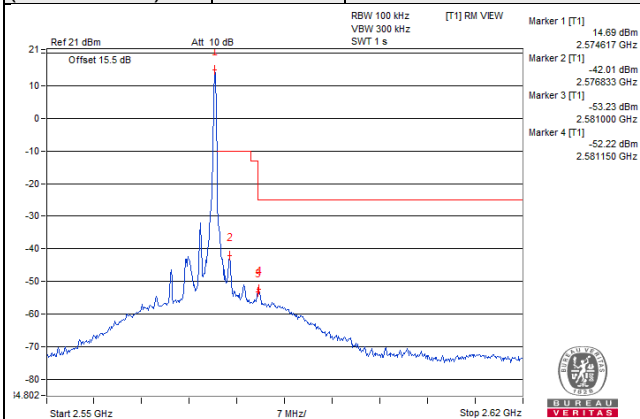

Channel 37775
(2572.5MHz)

QPSK

25 RB / 0 RB Offset

Channel 38225
(2617.5MHz)

QPSK

25 RB / 0 RB Offset

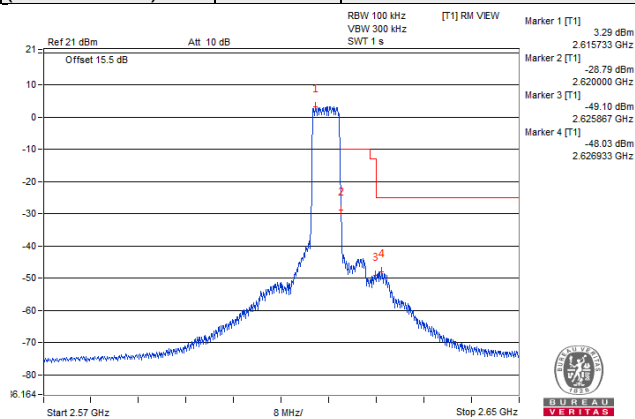
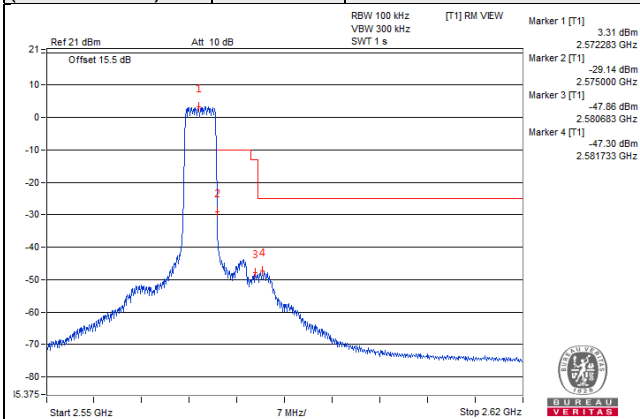

Channel Bandwidth: 10MHz_Edge

Channel 37800 (2575.0MHz)	QPSK	1 RB / 0 RB Offset	Channel 38200 (2615.0MHz)	QPSK	1 RB / 49 RB Offset
--------------------------------------	-------------	---------------------------	--------------------------------------	-------------	----------------------------

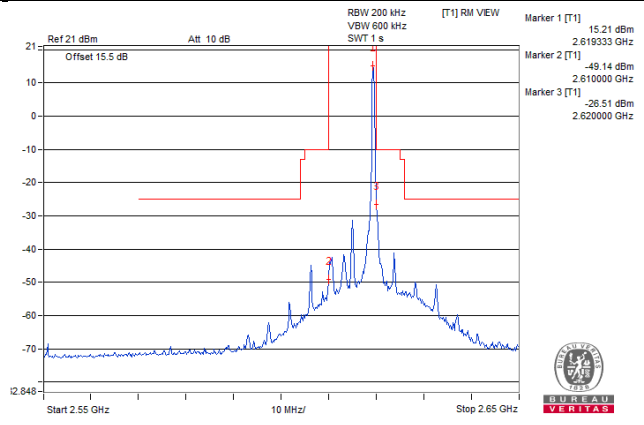
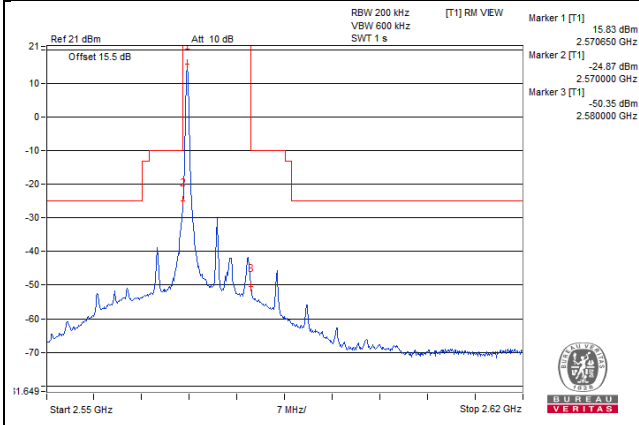

Channel 37800 (2575.0MHz)	QPSK	50 RB / 0 RB Offset	Channel 38200 (2615.0MHz)	QPSK	50 RB / 0 RB Offset
--------------------------------------	-------------	----------------------------	--------------------------------------	-------------	----------------------------

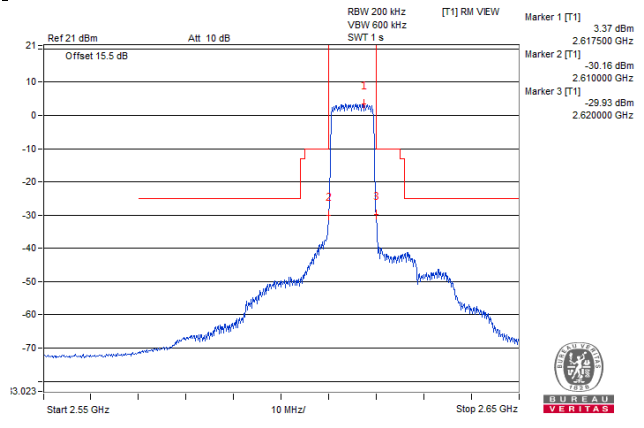
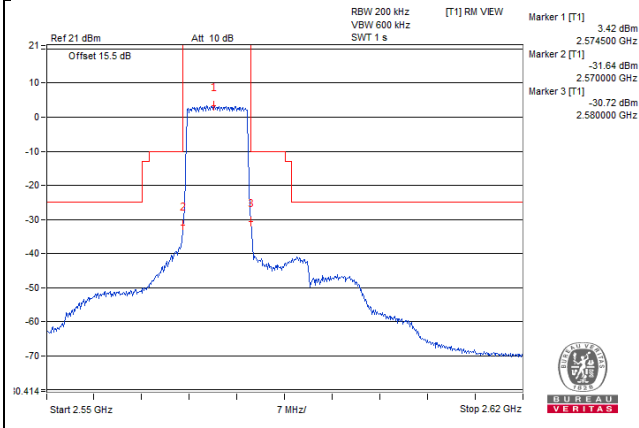

Channel Bandwidth: 10MHz_Left

Channel 37800 (2575.0MHz)	QPSK	1 RB / 0 RB Offset	Channel 38200 (2615.0MHz)	QPSK	1 RB / 49 RB Offset
------------------------------	------	--------------------	------------------------------	------	---------------------

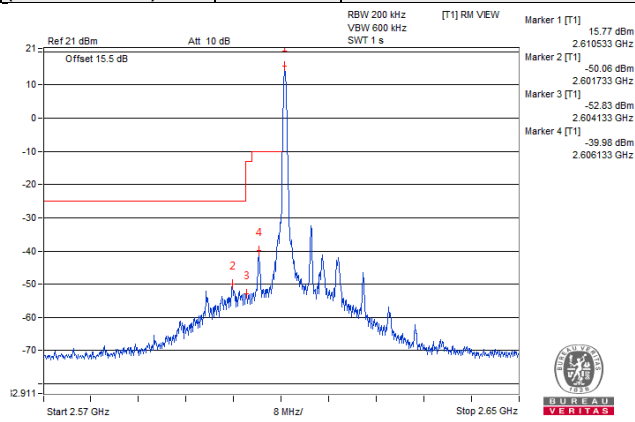
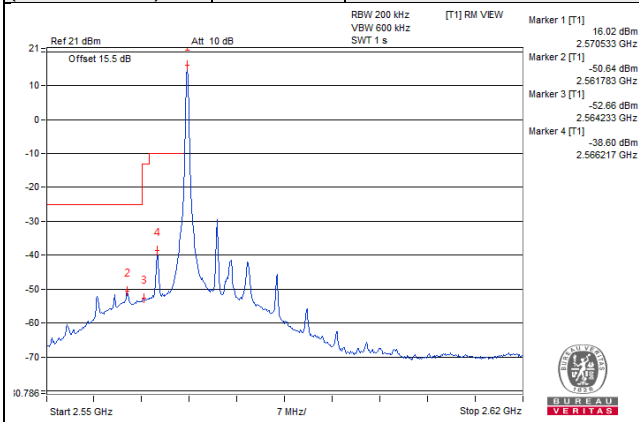

Channel 37800 (2575.0MHz)	QPSK	50 RB / 0 RB Offset	Channel 38200 (2615.0MHz)	QPSK	50 RB / 0 RB Offset
------------------------------	------	---------------------	------------------------------	------	---------------------

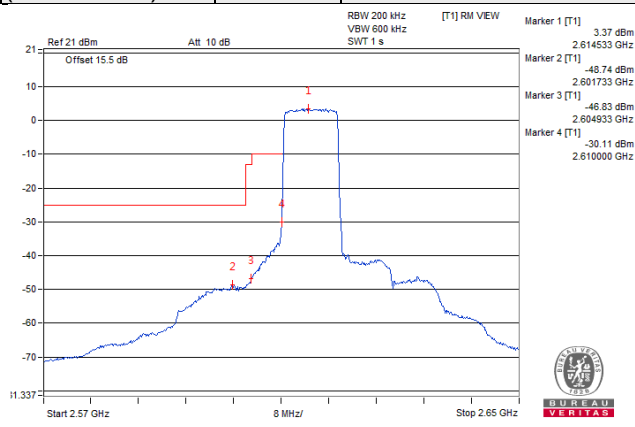
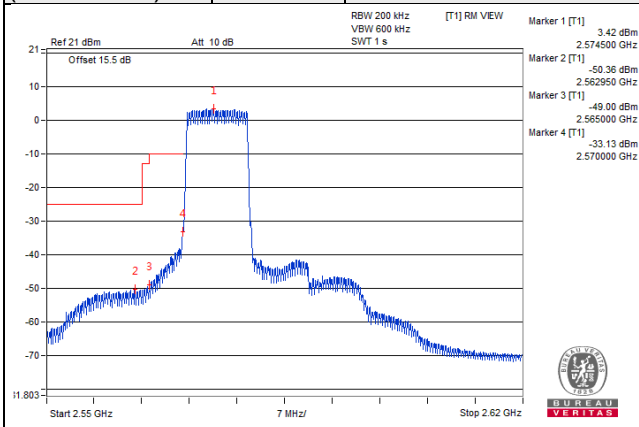

Channel Bandwidth: 10MHz_Right

Channel 37800 (2575.0MHz)	QPSK	1 RB / 0 RB Offset	Channel 38200 (2615.0MHz)	QPSK	1 RB / 49 RB Offset
------------------------------	------	--------------------	------------------------------	------	---------------------

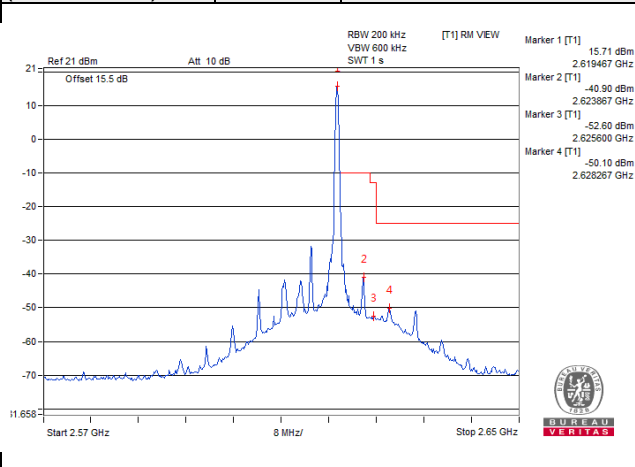
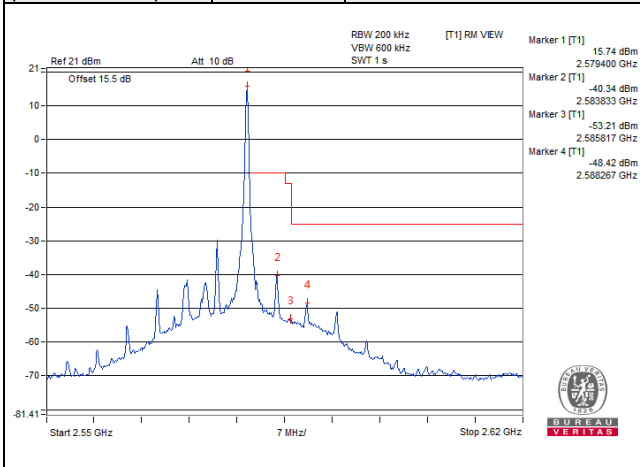

Channel 37800 (2575.0MHz)	QPSK	50 RB / 0 RB Offset	Channel 38200 (2615.0MHz)	QPSK	50 RB / 0 RB Offset
------------------------------	------	---------------------	------------------------------	------	---------------------

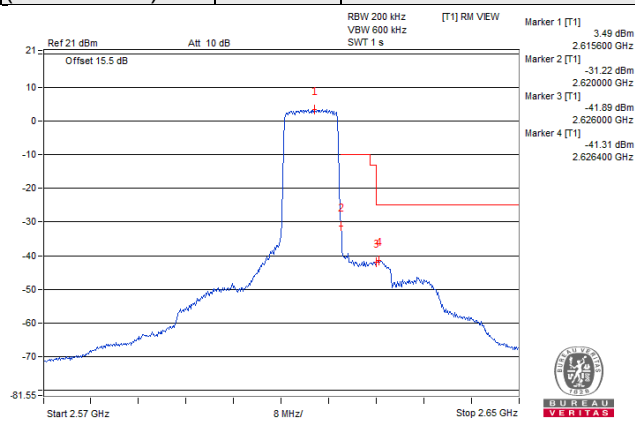
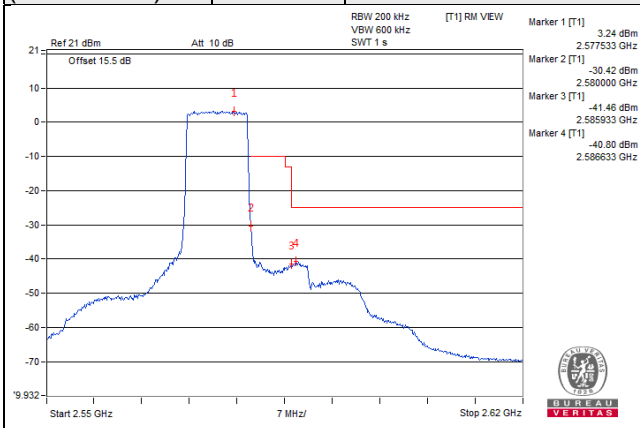

Channel Bandwidth: 15MHz_Edge

**Channel 37825
(2577.5MHz)**

QPSK

1 RB / 0 RB Offset

**Channel 38175
(2612.5MHz)**

QPSK

1 RB / 74RB Offset

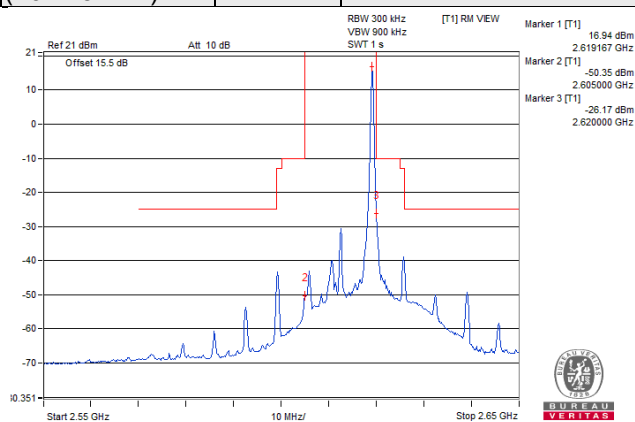
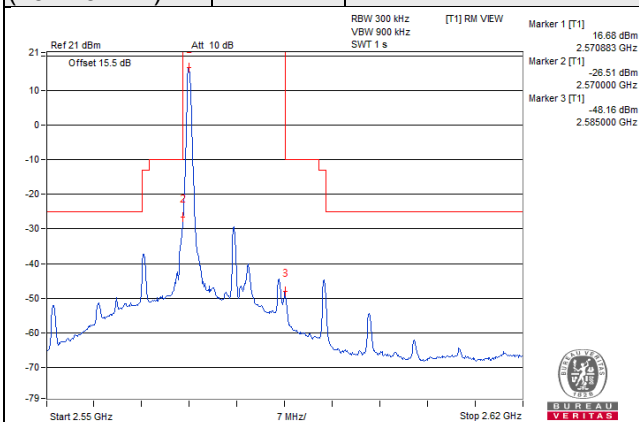

**Channel 37825
(2577.5MHz)**

QPSK

75 RB / 0 RB Offset

**Channel 38175
(2612.5MHz)**

QPSK

75 RB / 0 RB Offset

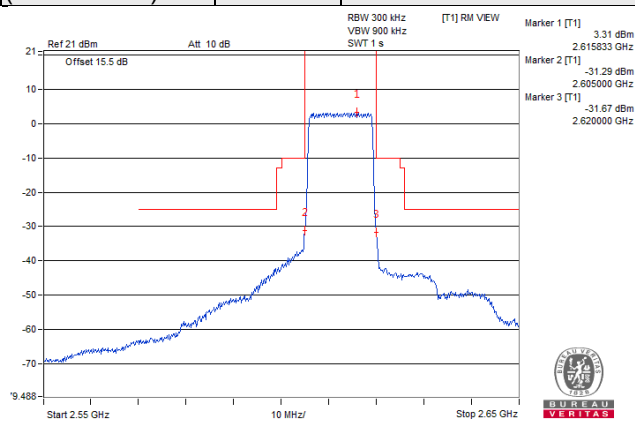
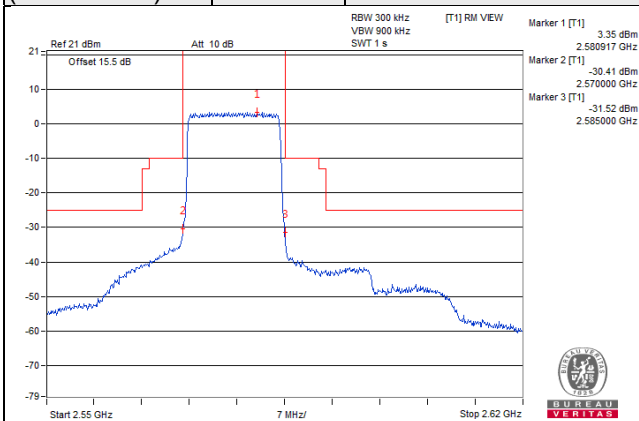

Channel Bandwidth: 15MHz_Left

Channel 37825 (2577.5MHz)	QPSK	1 RB / 0 RB Offset	Channel 38175 (2612.5MHz)	QPSK	1 RB / 74RB Offset
--------------------------------------	-------------	---------------------------	--------------------------------------	-------------	---------------------------

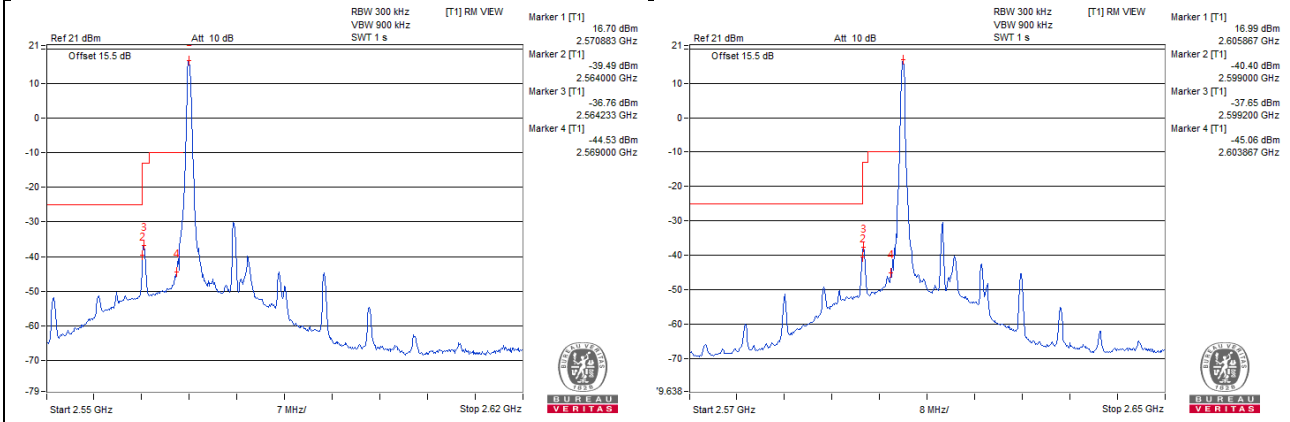

Channel 37825 (2577.5MHz)	QPSK	75 RB / 0 RB Offset	Channel 38175 (2612.5MHz)	QPSK	75 RB / 0 RB Offset
--------------------------------------	-------------	----------------------------	--------------------------------------	-------------	----------------------------

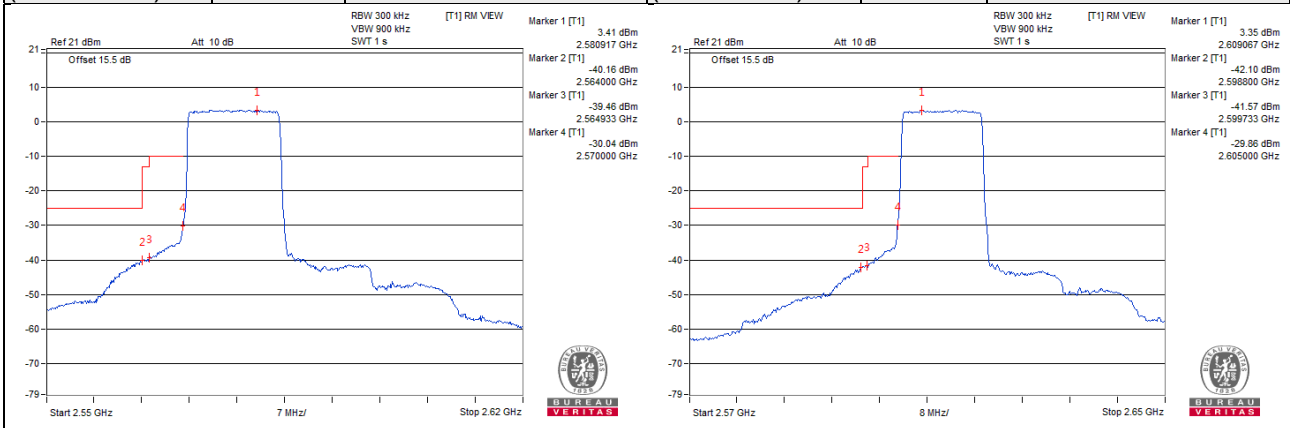

Channel Bandwidth: 15MHz_Right

**Channel 37825
(2577.5MHz)**

QPSK

1 RB / 0 RB Offset

**Channel 38175
(2612.5MHz)**

QPSK

1 RB / 74RB Offset

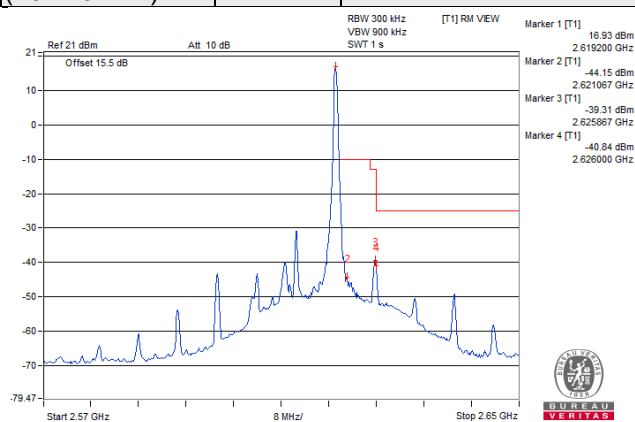
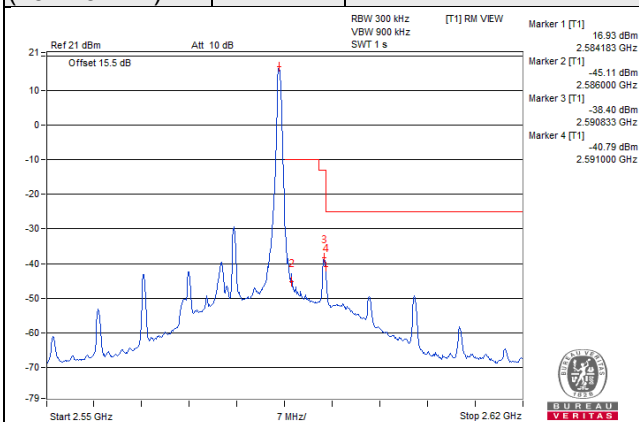

**Channel 37825
(2577.5MHz)**

QPSK

75 RB / 0 RB Offset

**Channel 38175
(2612.5MHz)**

QPSK

75 RB / 0 RB Offset

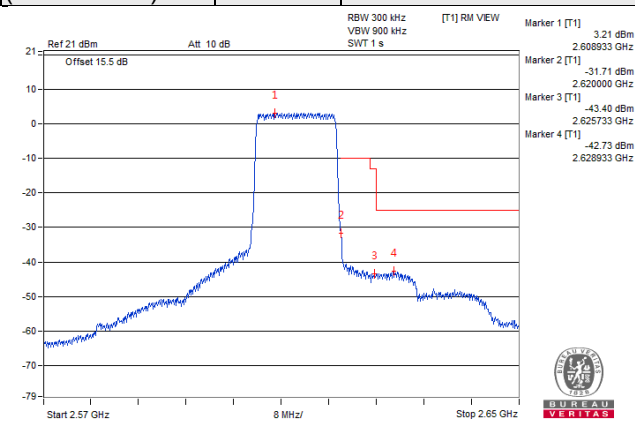
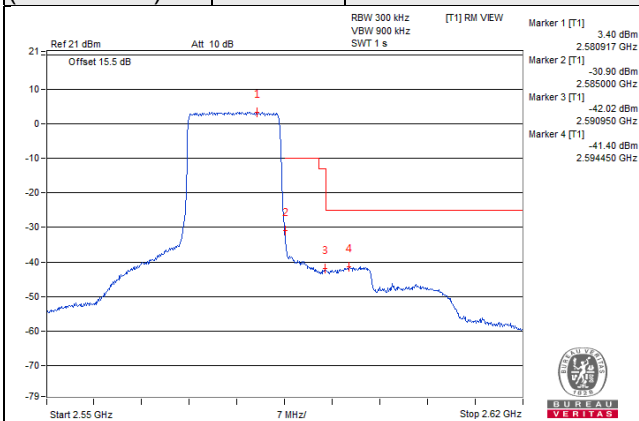

Channel Bandwidth: 20MHz_Edge

Channel 37850 (2580.0MHz)	QPSK	1 RB / 0 RB Offset	Channel 38150 (2610.0MHz)	QPSK	1 RB / 99 RB Offset
------------------------------	------	--------------------	------------------------------	------	---------------------

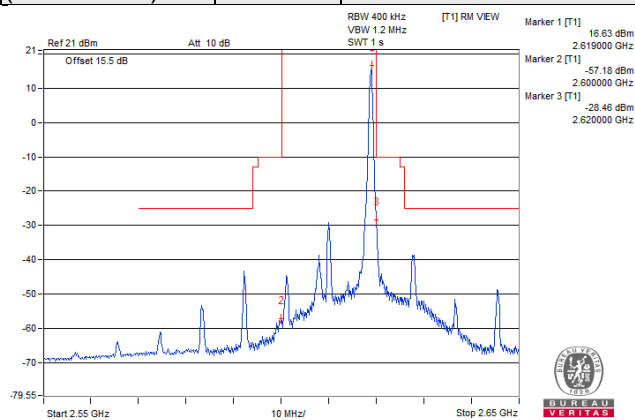
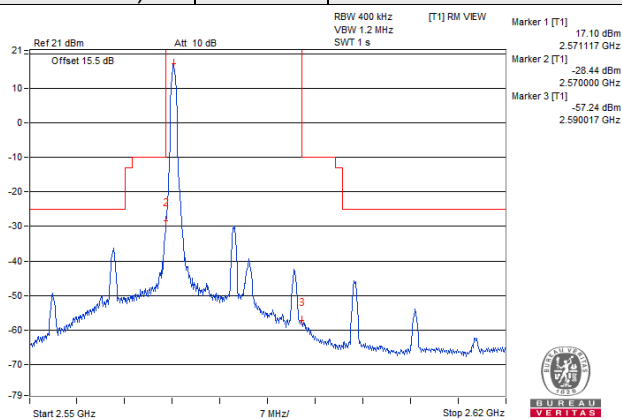

Channel 37850 (2580.0MHz)	QPSK	100 RB / 0 RB Offset	Channel 38150 (2610.0MHz)	QPSK	100 RB / 0 RB Offset
------------------------------	------	----------------------	------------------------------	------	----------------------

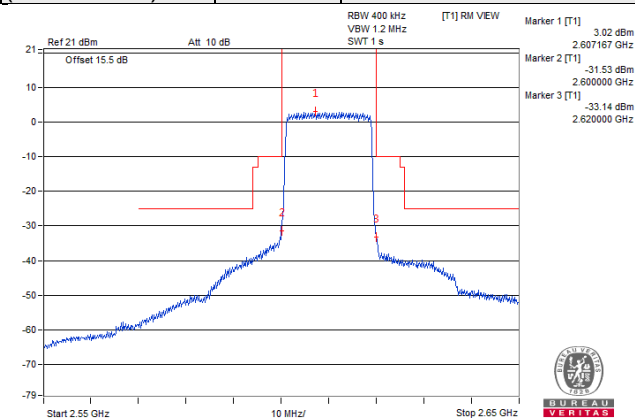
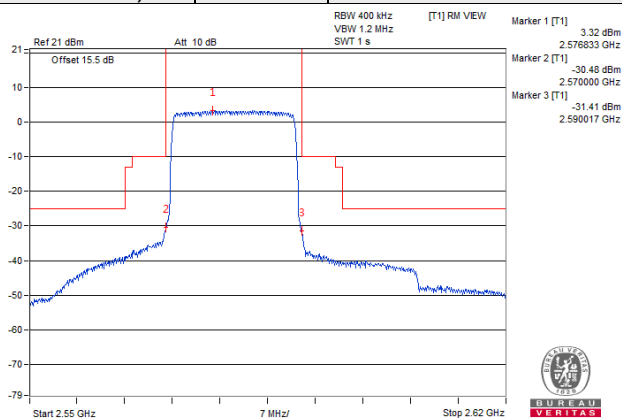

Channel Bandwidth: 20MHz_Left

Channel 37850
(2580.0MHz)

QPSK

1 RB / 0 RB Offset

Channel 38150
(2610.0MHz)

QPSK

1 RB / 99 RB Offset

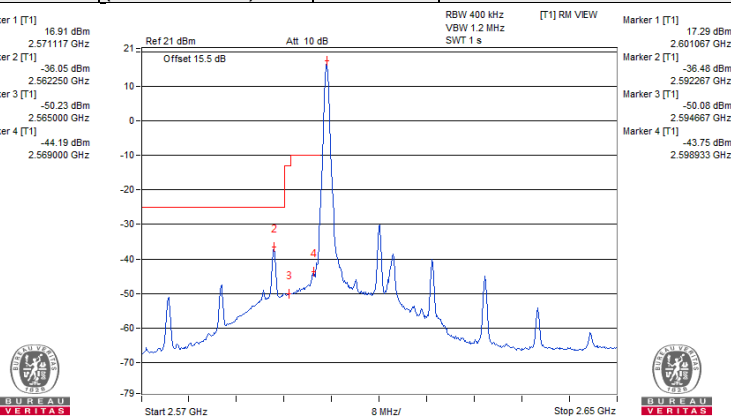
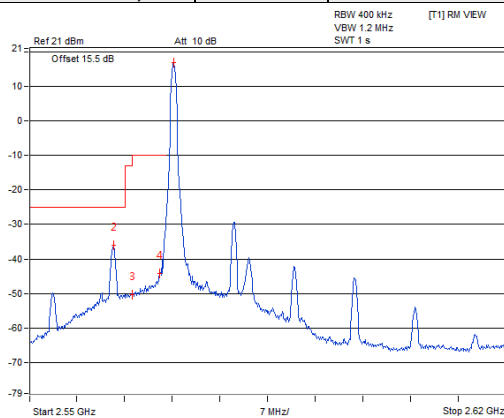

Channel 37850
(2580.0MHz)

QPSK

100 RB / 0 RB Offset

Channel 38150
(2610.0MHz)

QPSK

100 RB / 0 RB Offset

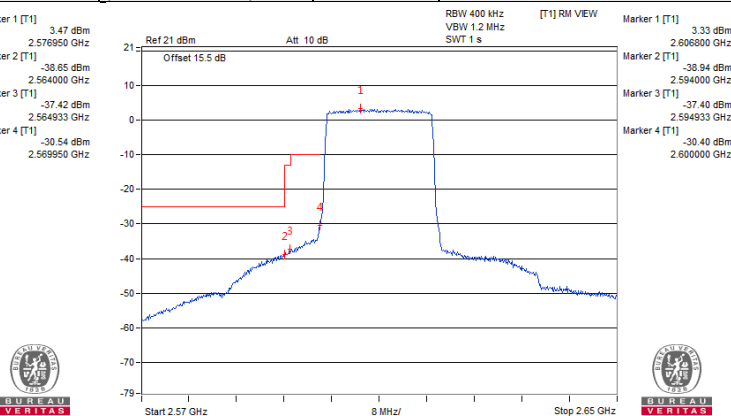
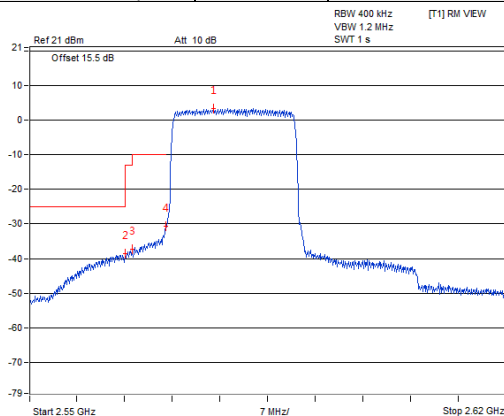

Channel Bandwidth: 20MHz_Right

Channel 37850 (2580.0MHz)	QPSK	1 RB / 0 RB Offset	Channel 38150 (2610.0MHz)	QPSK	1 RB / 99 RB Offset
--------------------------------------	-------------	---------------------------	--------------------------------------	-------------	----------------------------

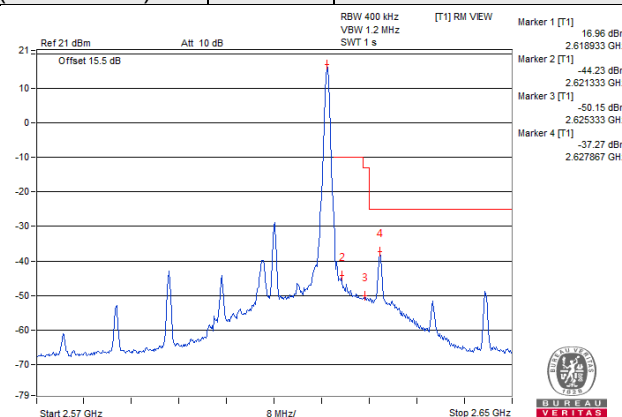
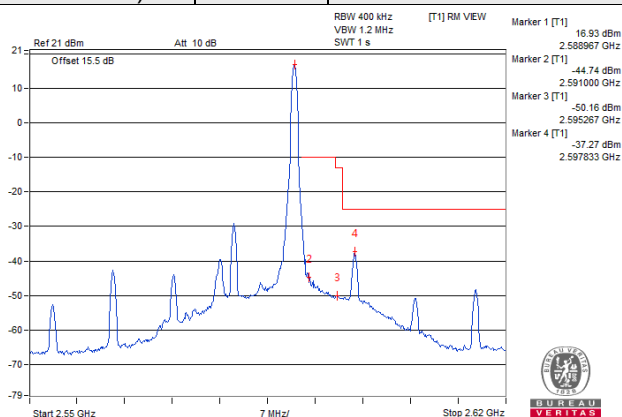

Channel 37850 (2580.0MHz)	QPSK	100 RB / 0 RB Offset	Channel 38150 (2610.0MHz)	QPSK	100 RB / 0 RB Offset
--------------------------------------	-------------	-----------------------------	--------------------------------------	-------------	-----------------------------

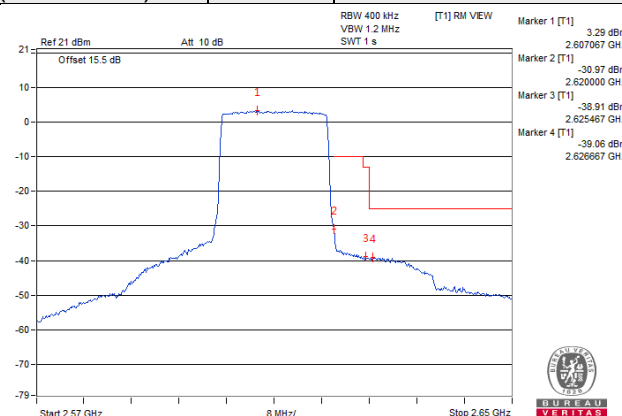
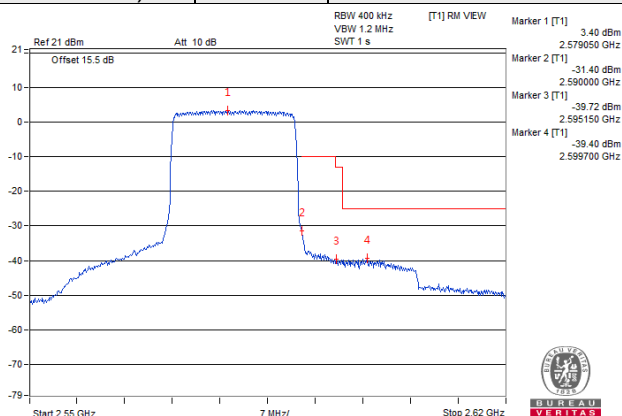

LTE Band 41

Channel Bandwidth: 5MHz_Left

Channel 40065 (2537.5MHz)	QPSK	1 RB / 0 RB Offset	Channel 41215 (2652.5MHz)	QPSK	1 RB / 24 RB Offset
------------------------------	------	--------------------	------------------------------	------	---------------------

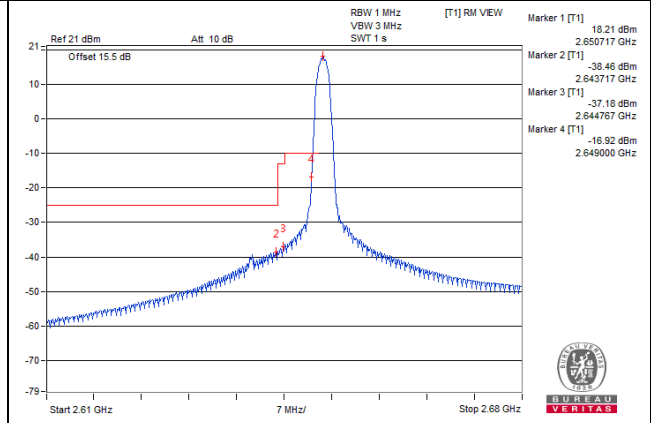
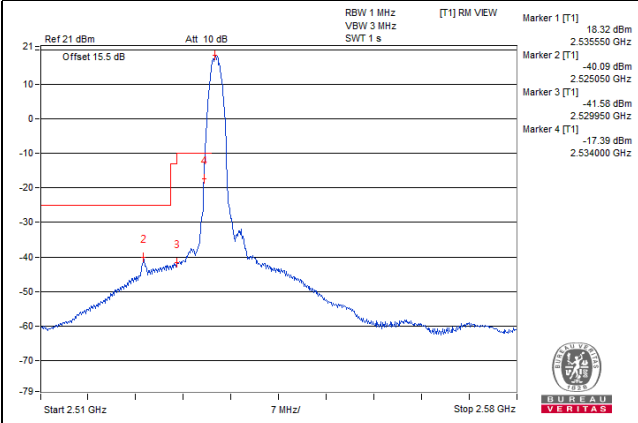

Channel 40065 (2537.5MHz)	QPSK	25 RB / 0 RB Offset	Channel 41215 (2652.5MHz)	QPSK	25 RB / 0 RB Offset
------------------------------	------	---------------------	------------------------------	------	---------------------

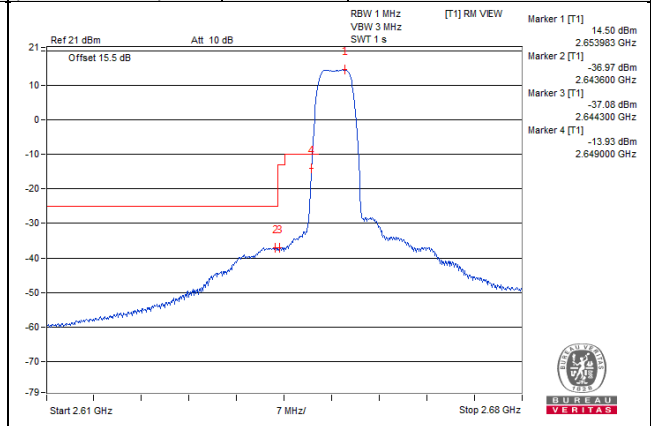
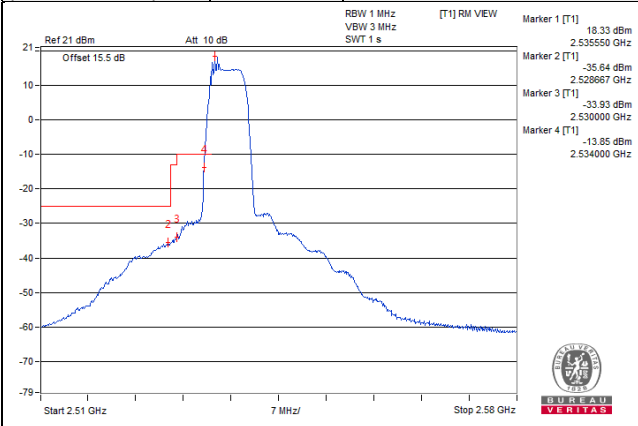

Channel Bandwidth: 5MHz_Right

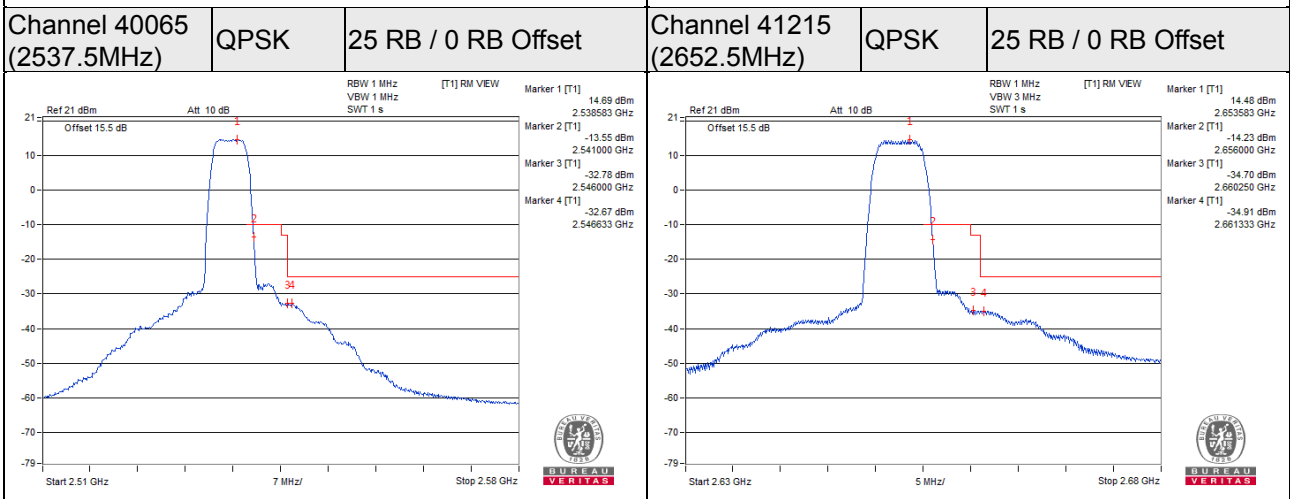
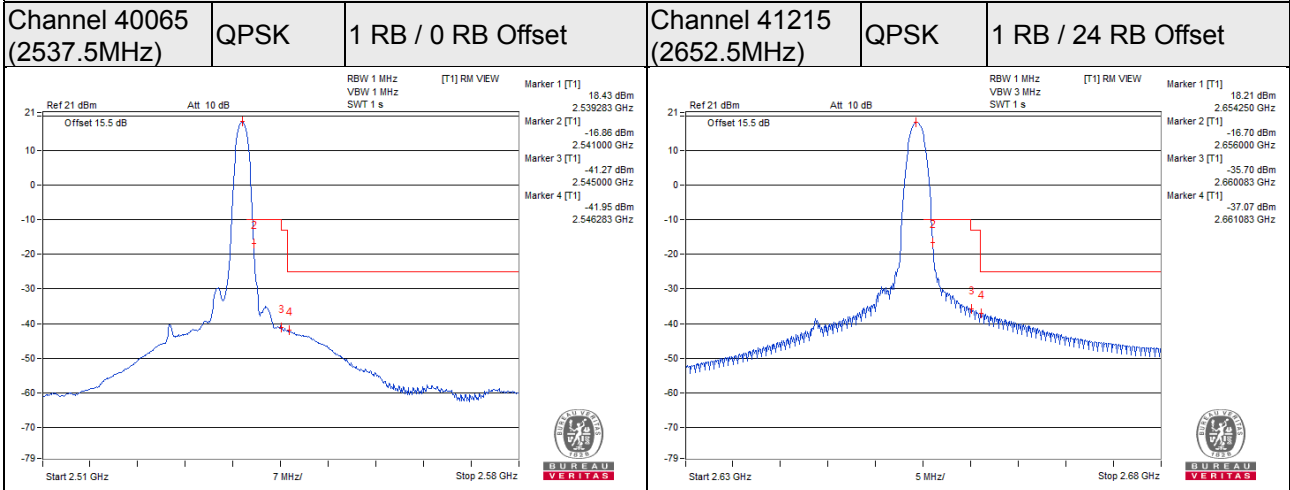

Channel Bandwidth: 10MHz_Left

Channel 40090
(2540.0MHz)

QPSK

1 RB / 0 RB Offset

Channel 41190
(2650.0MHz)

QPSK

1 RB / 49 RB Offset

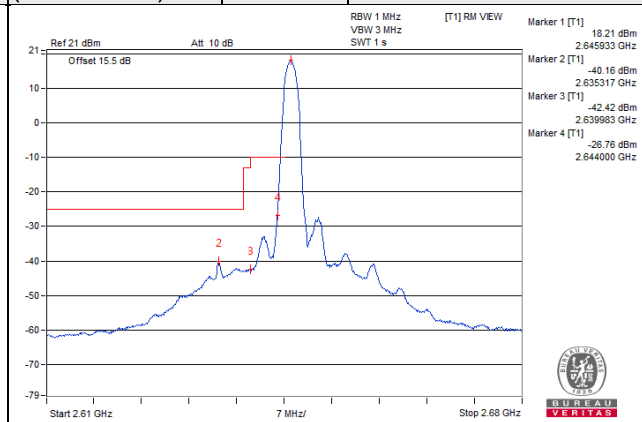
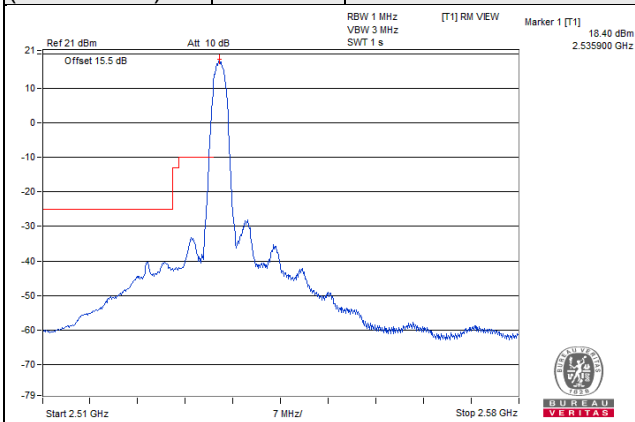

Channel 40090
(2540.0MHz)

QPSK

50 RB / 0 RB Offset

Channel 41190
(2650.0MHz)

QPSK

50 RB / 0 RB Offset

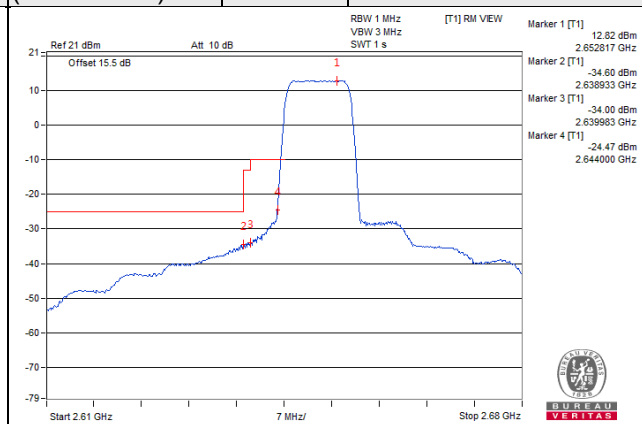
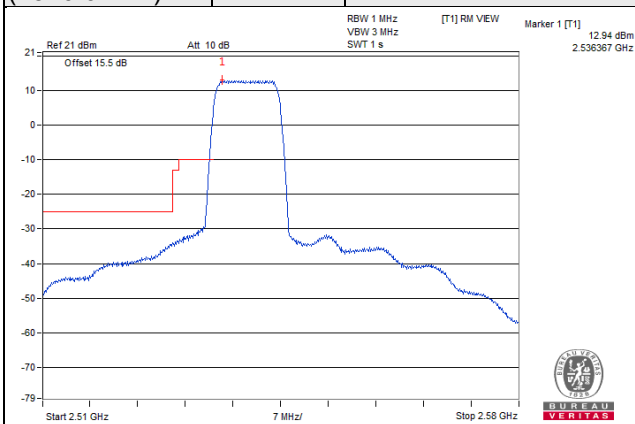

Channel Bandwidth: 10MHz_Right

Channel 40090
(2540.0MHz)

QPSK

1 RB / 0 RB Offset

Channel 41190
(2650.0MHz)

QPSK

1 RB / 49 RB Offset

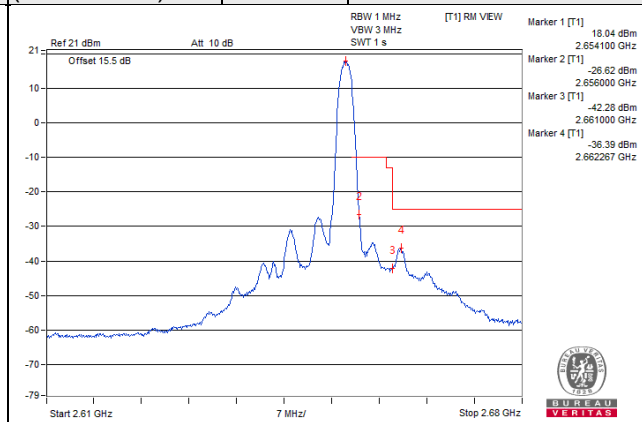
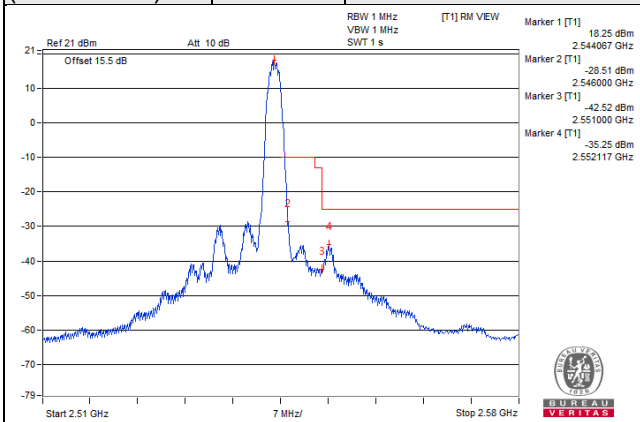

Channel 40090
(2540.0MHz)

QPSK

50 RB / 0 RB Offset

Channel 41190
(2650.0MHz)

QPSK

50 RB / 0 RB Offset

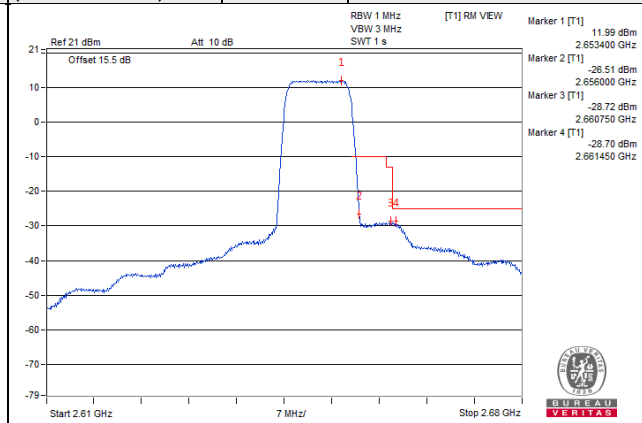
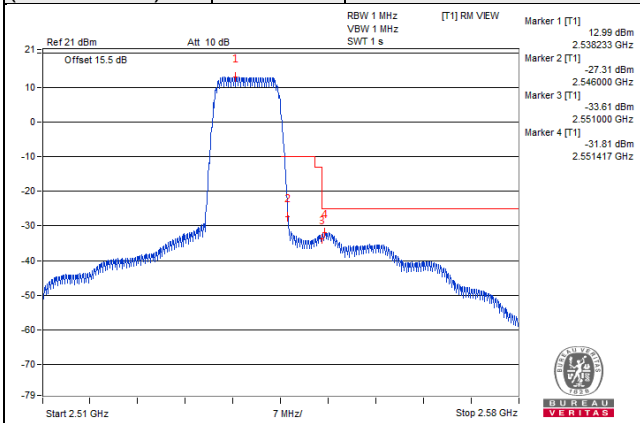

Channel Bandwidth: 15MHz_Left

Channel 40115
(2542.5MHz)

QPSK

1 RB / 0 RB Offset

Channel 41165
(2647.5MHz)

QPSK

1 RB / 74 RB Offset

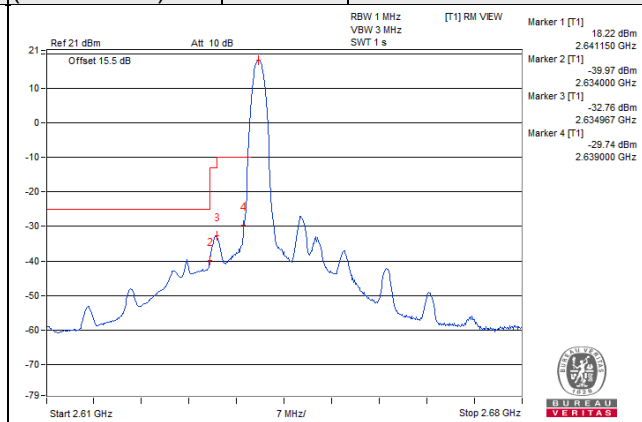
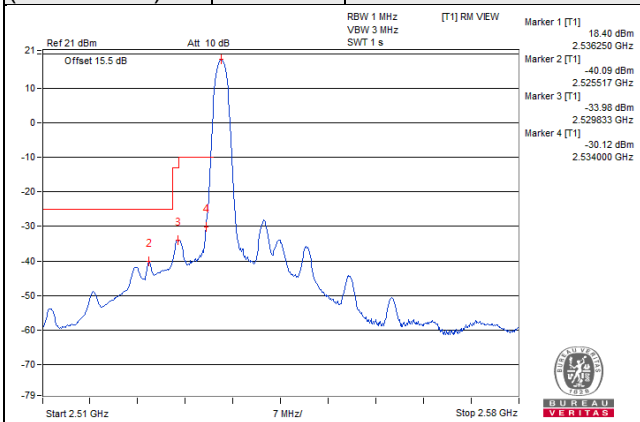

Channel 40115
(2542.5MHz)

QPSK

75 RB / 0 RB Offset

Channel 41165
(2647.5MHz)

QPSK

75 RB / 0 RB Offset

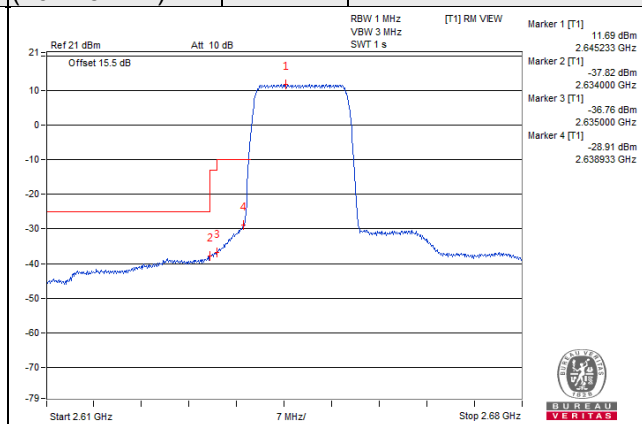
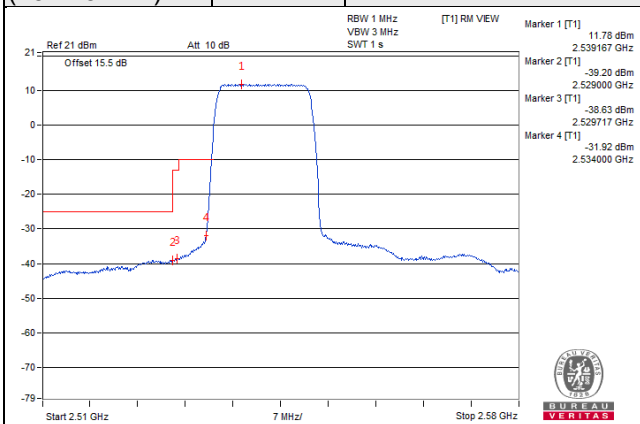

Channel Bandwidth: 15MHz_Right

Channel 40115
(2542.5MHz)

QPSK

1 RB / 0 RB Offset

Channel 41165
(2647.5MHz)

QPSK

1 RB / 74 RB Offset

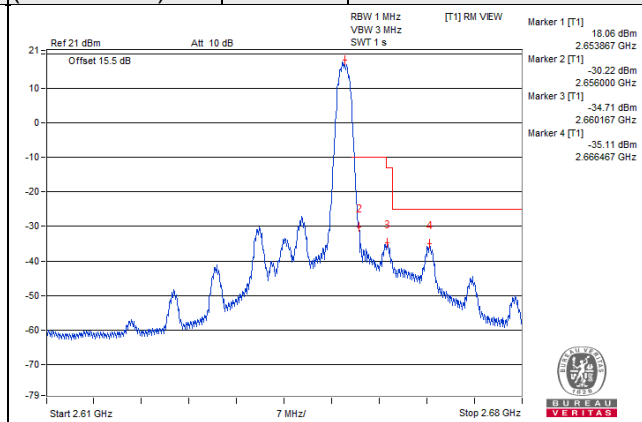
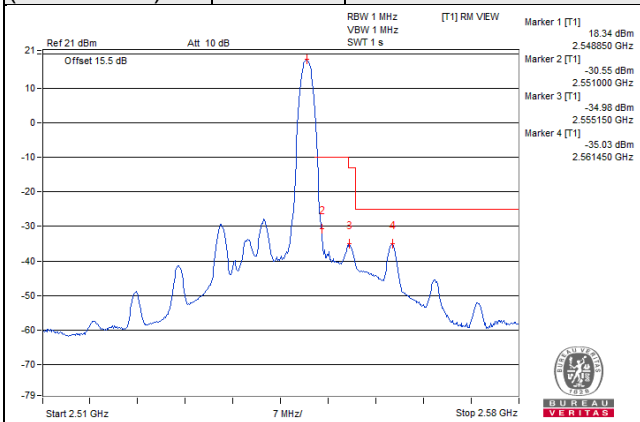

Channel 40115
(2542.5MHz)

QPSK

75 RB / 0 RB Offset

Channel 41165
(2647.5MHz)

QPSK

75 RB / 0 RB Offset

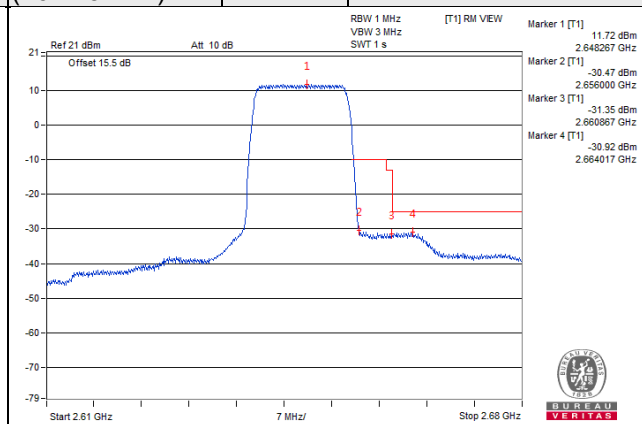
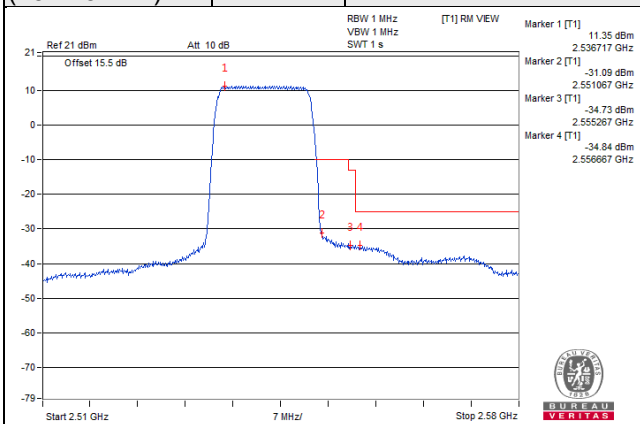

Channel Bandwidth: 20MHz_Left

Channel 40140
(2545.0MHz)

QPSK

1 RB / 0 RB Offset

Channel 41140
(2645.0MHz)

QPSK

1 RB / 99 RB Offset

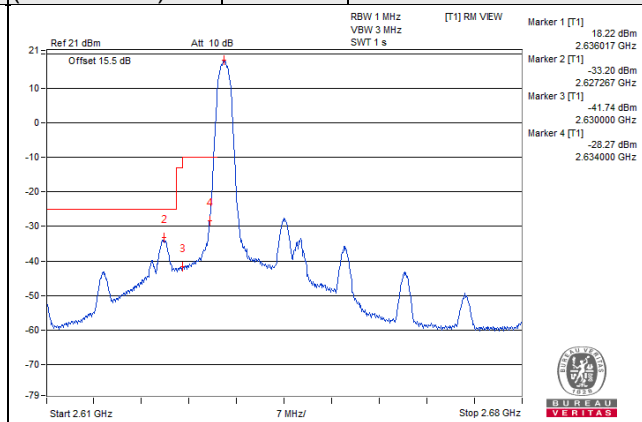
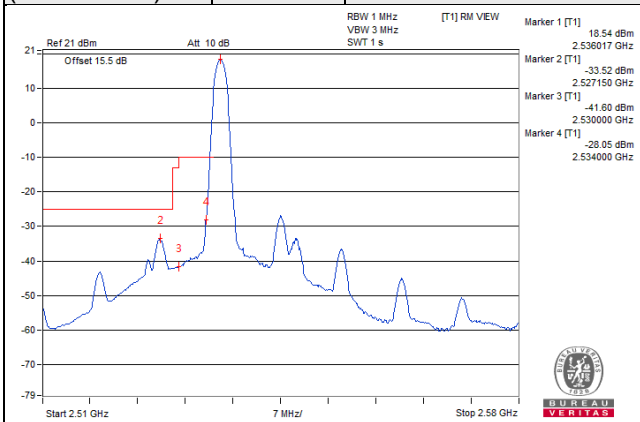

Channel 40140
(2545.0MHz)

QPSK

100 RB / 0 RB Offset

Channel 41140
(2645.0MHz)

QPSK

100 RB / 0 RB Offset

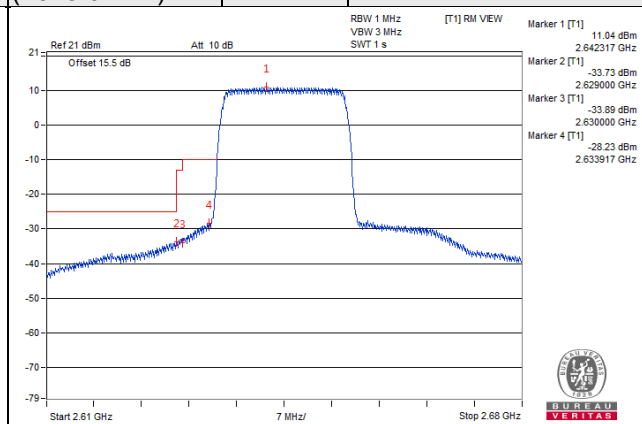
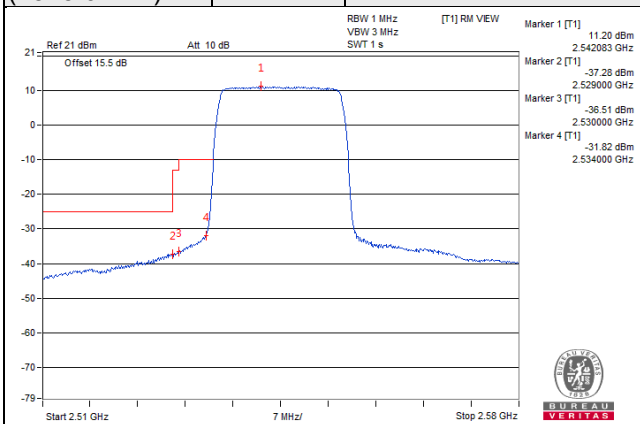

Channel Bandwidth: 20MHz_Right

Channel 40140
(2545.0MHz)

QPSK

1 RB / 0 RB Offset

Channel 41140
(2645.0MHz)

QPSK

1 RB / 99 RB Offset

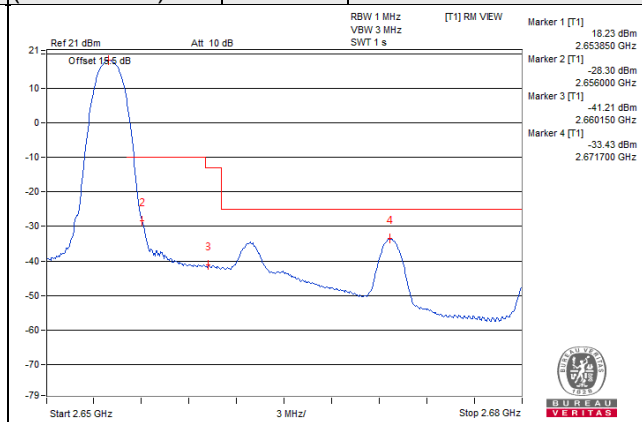
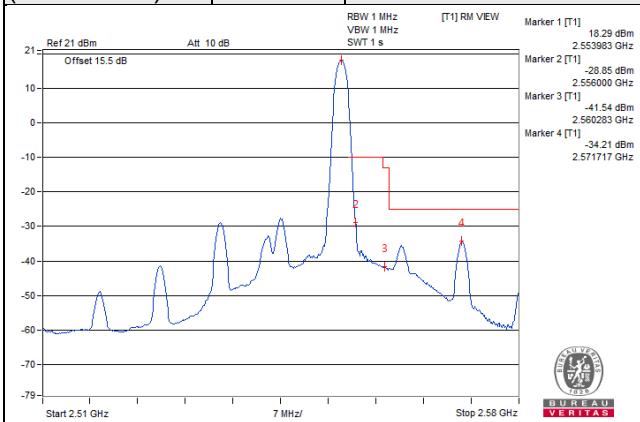

Channel 40140
(2545.0MHz)

QPSK

100 RB / 0 RB Offset

Channel 41140
(2645.0MHz)

QPSK

100 RB / 0 RB Offset

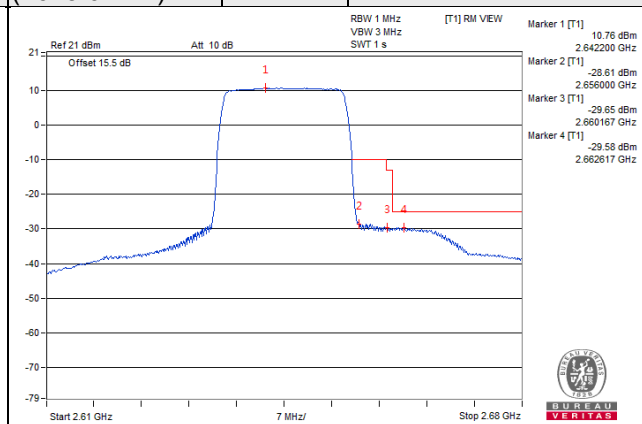
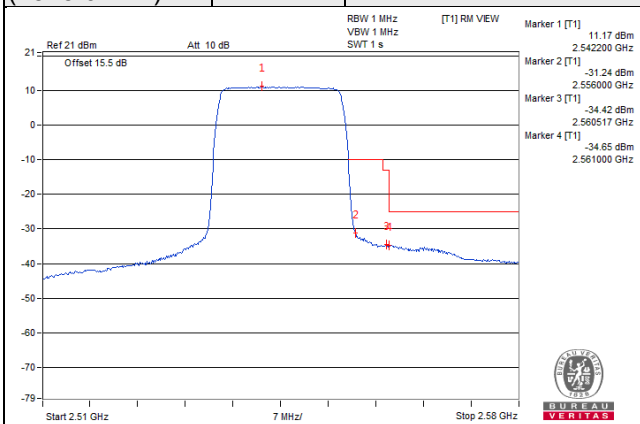

LTE Band 66

Channel Bandwidth: 1.4MHz

Channel 131979 (1710.7MHz)	QPSK	1 RB / 0 RB Offset	Channel 132665 (1779.3MHz)	QPSK	1 RB / 5 RB Offset
-------------------------------	------	--------------------	-------------------------------	------	--------------------

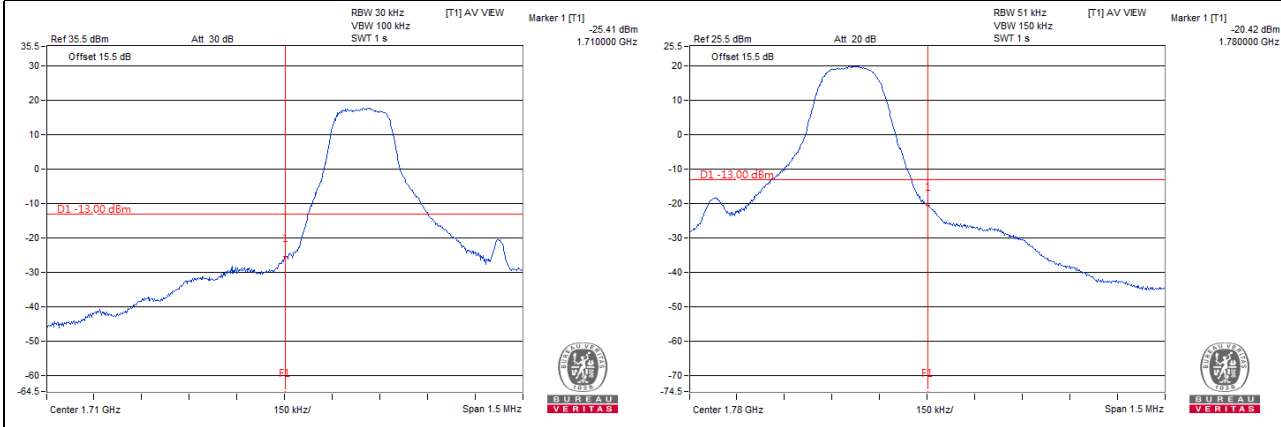

Channel 131979 (1710.7MHz)	QPSK	6 RB / 0 RB Offset	Channel 132665 (1779.3MHz)	QPSK	6 RB / 0 RB Offset
-------------------------------	------	--------------------	-------------------------------	------	--------------------

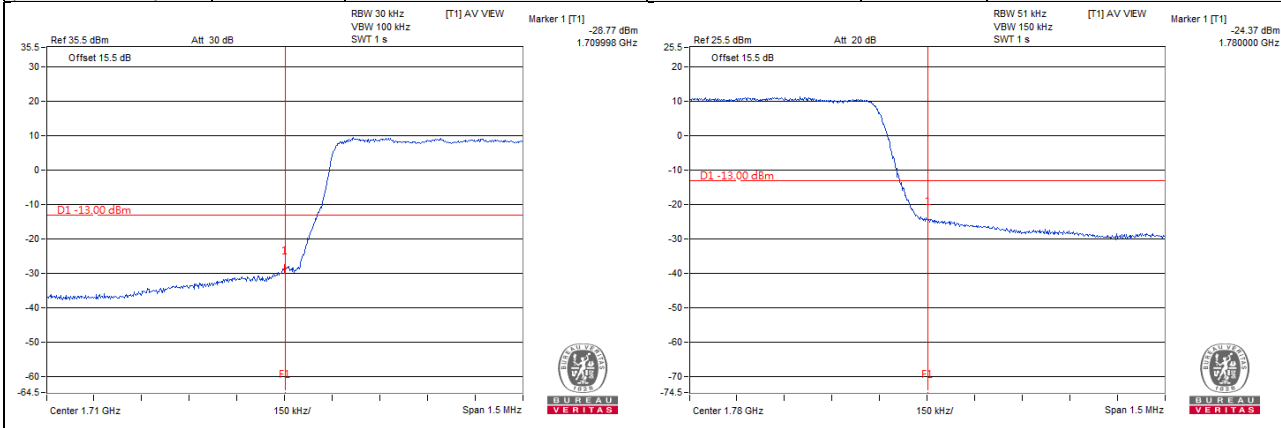

Channel Bandwidth: 3MHz

Channel 131987 (1711.5MHz)	QPSK	1 RB / 0 RB Offset	Channel 132657 (1778.5MHz)	QPSK	1 RB / 14 RB Offset
---------------------------------------	-------------	---------------------------	---------------------------------------	-------------	----------------------------

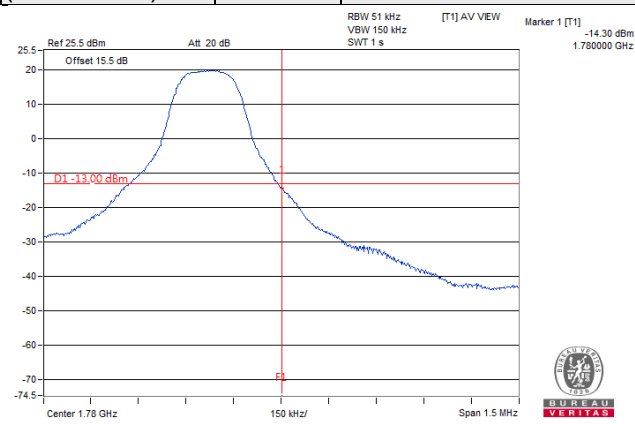
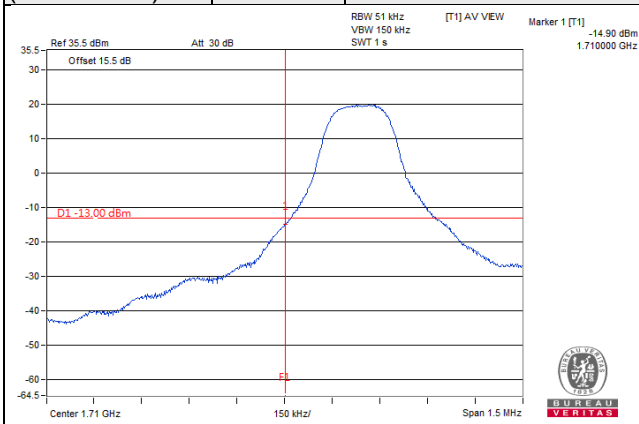

Channel 131987 (1711.5MHz)	QPSK	15 RB / 0 RB Offset	Channel 132657 (1778.5MHz)	QPSK	15 RB / 0 RB Offset
---------------------------------------	-------------	----------------------------	---------------------------------------	-------------	----------------------------

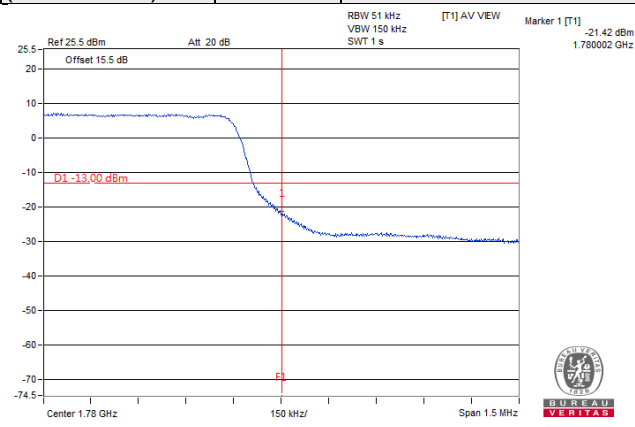
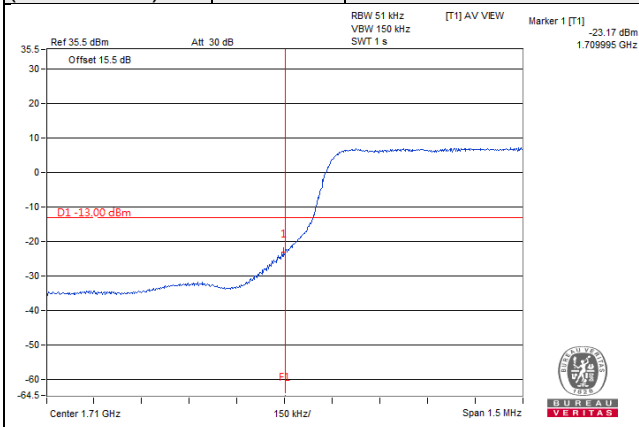

Channel Bandwidth: 5MHz

Channel 131997 (1712.5MHz)	QPSK	1 RB / 0 RB Offset	Channel 132647 (1777.5MHz)	QPSK	1 RB / 24 RB Offset
---------------------------------------	-------------	---------------------------	---------------------------------------	-------------	----------------------------

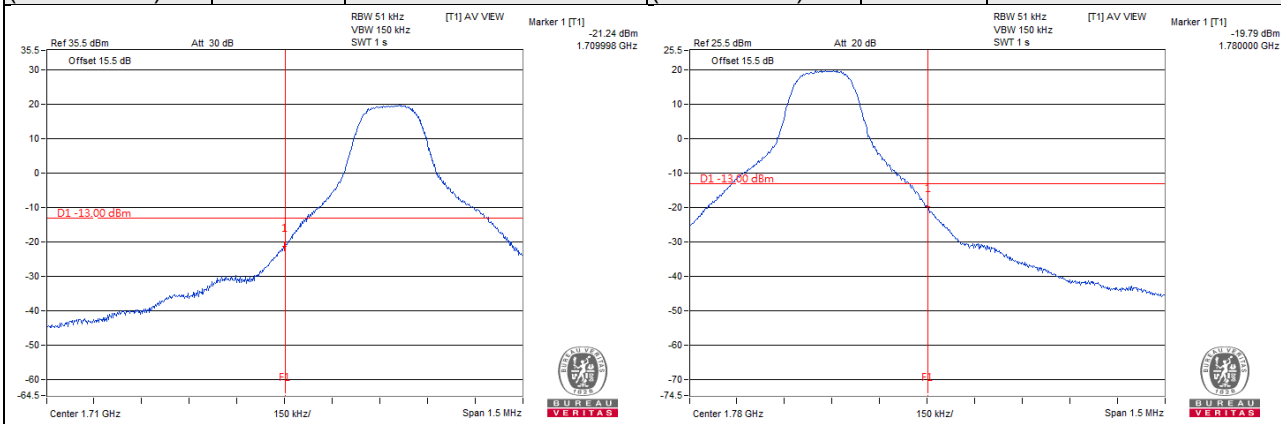

Channel 131997 (1712.5MHz)	QPSK	25 RB / 0 RB Offset	Channel 132647 (1777.5MHz)	QPSK	25 RB / 0 RB Offset
---------------------------------------	-------------	----------------------------	---------------------------------------	-------------	----------------------------

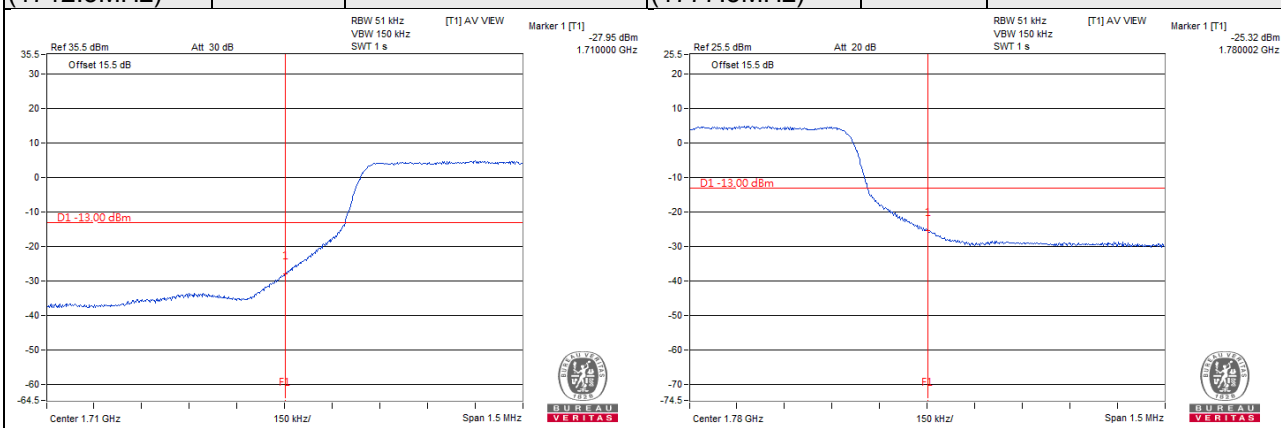

Channel Bandwidth: 10MHz

**Channel 132022
(1715.0MHz)**

QPSK

1 RB / 0 RB Offset

**Channel 132622
(1775MHz)**

QPSK

1 RB / 49 RB Offset

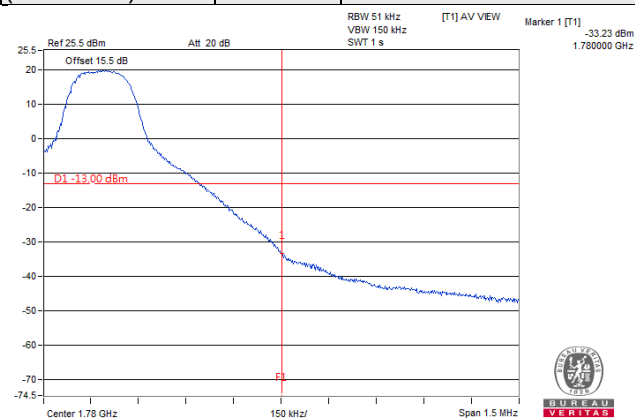
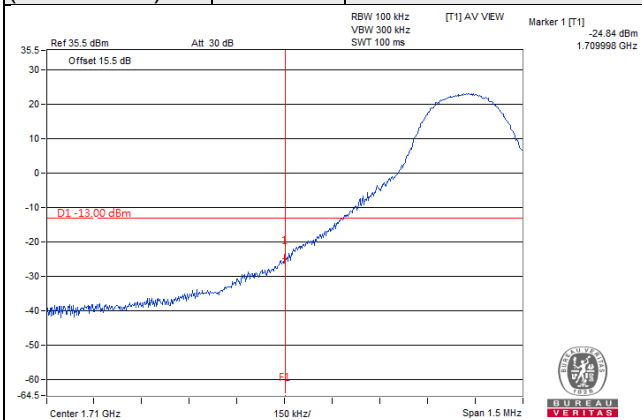

**Channel 132022
(1715.0MHz)**

QPSK

50 RB / 0 RB Offset

**Channel 132622
(1775MHz)**

QPSK

50 RB / 0 RB Offset

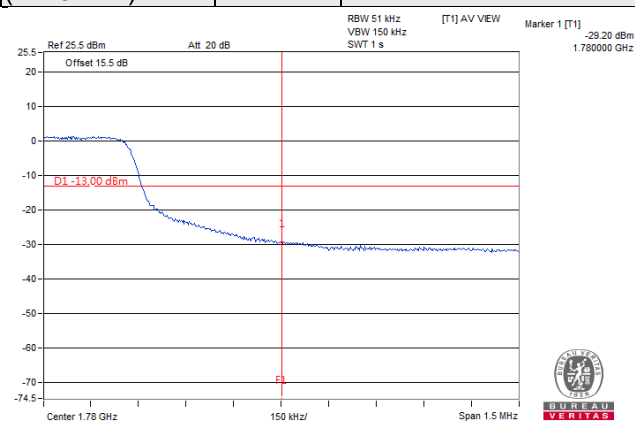
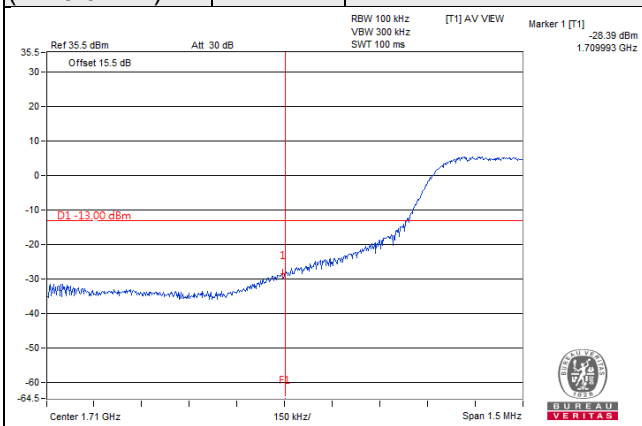

Channel Bandwidth: 15MHz

Channel 132047 (1717.5MHz)	QPSK	1 RB / 0 RB Offset	Channel 132597 (1772.5MHz)	QPSK	1 RB / 74 RB Offset
---------------------------------------	-------------	---------------------------	---------------------------------------	-------------	----------------------------

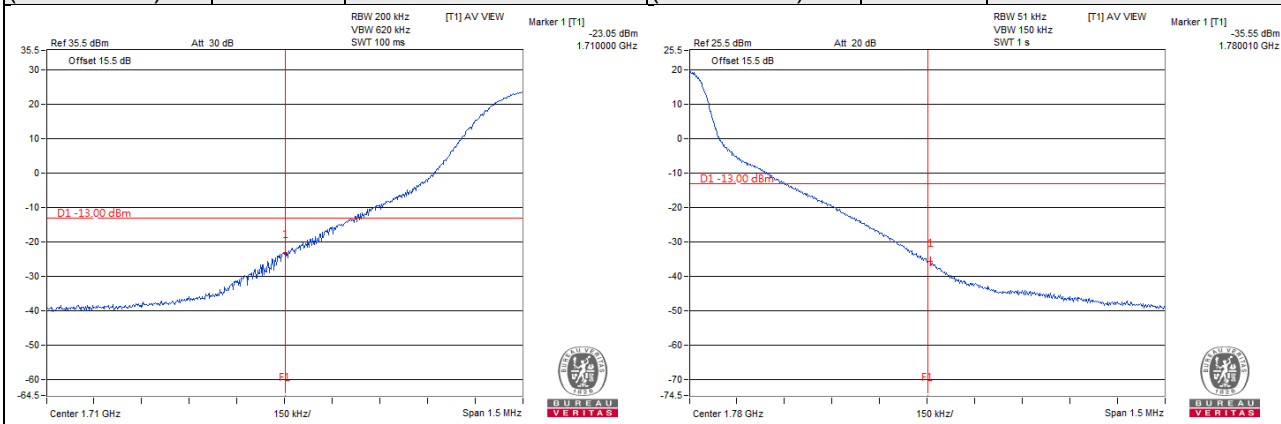

Channel 132047 (1717.5MHz)	QPSK	75 RB / 0 RB Offset	Channel 132597 (1772.5MHz)	QPSK	75 RB / 0 RB Offset
---------------------------------------	-------------	----------------------------	---------------------------------------	-------------	----------------------------

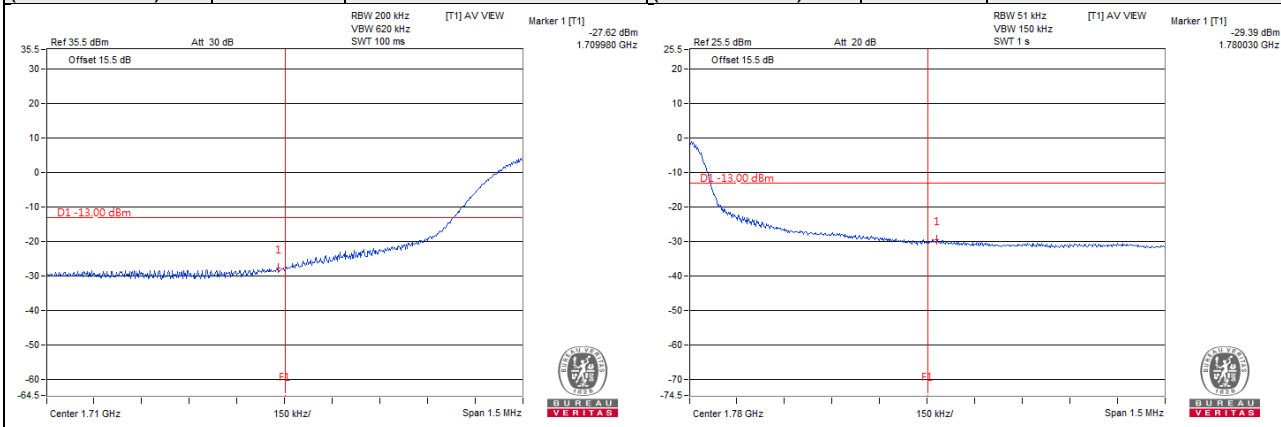

Channel Bandwidth: 20MHz

Channel 132072 (1720.0MHz)	QPSK	1 RB / 0 RB Offset	Channel 132572 (1770MHz)	QPSK	1 RB / 99 RB Offset
---------------------------------------	-------------	---------------------------	-------------------------------------	-------------	----------------------------

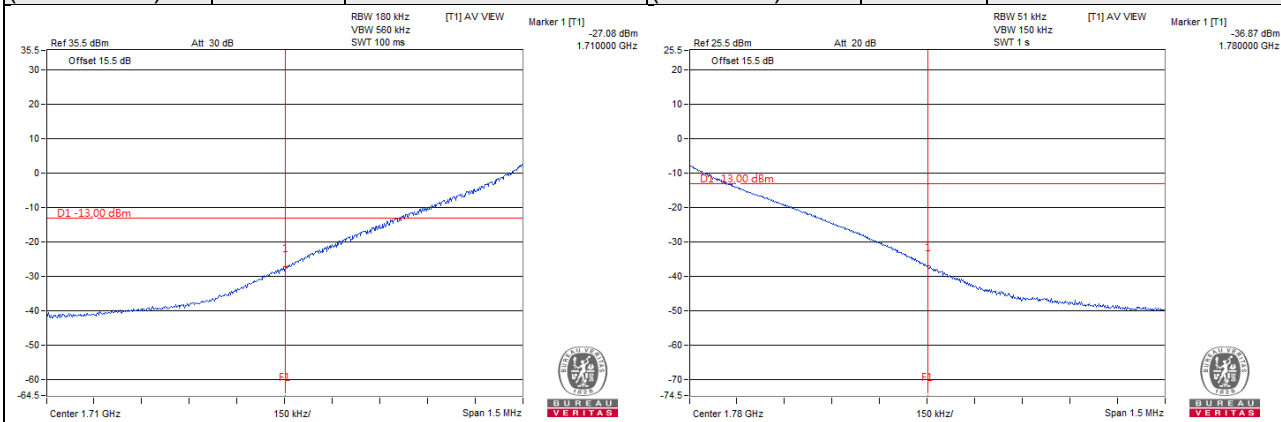

Channel 132072 (1720.0MHz)	QPSK	100 RB / 0 RB Offset	Channel 132572 (1770MHz)	QPSK	100 RB / 0 RB Offset
---------------------------------------	-------------	-----------------------------	-------------------------------------	-------------	-----------------------------

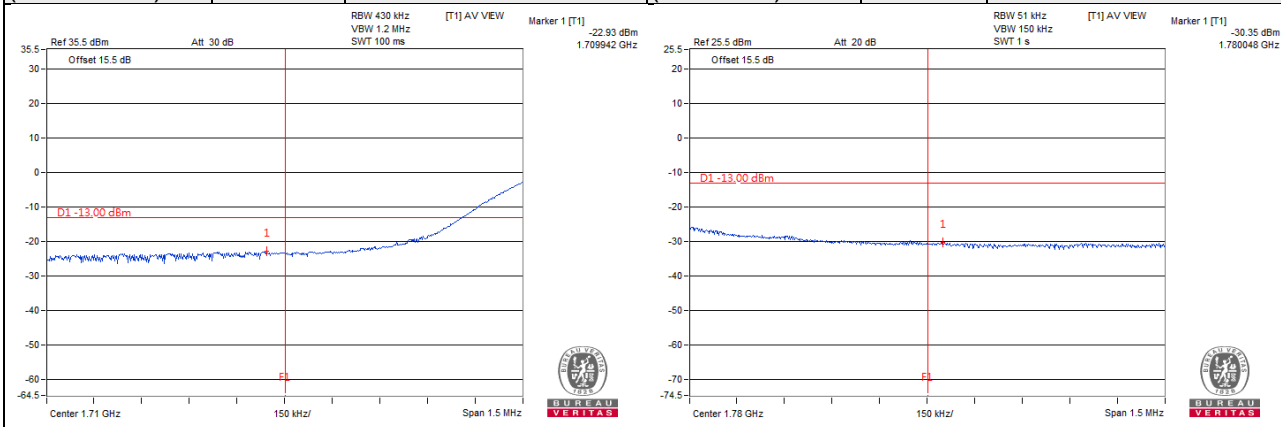

4.6 Peak to Average Ratio

4.6.1 Limits of Peak to Average Ratio Measurement

In measuring transmissions in this band using an average power technique, the peak to-average ratio (PAR) of the transmission may not exceed 13 dB

4.6.2 Test Setup

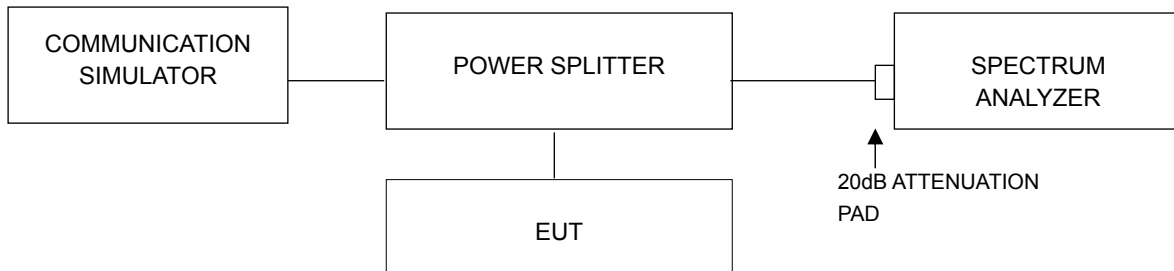

4.6.3 Test Procedures

- Set resolution/measurement bandwidth \geq signal's occupied bandwidth;
- Set the number of counts to a value that stabilizes the measured CCDF curve;
- Record the maximum PAPR level associated with a probability of 0.1%.

4.6.4 Test Results

WCDMA Band 4

Channel	Frequency (MHz)	Peak To Average Ratio (dB)
		WCDMA
1312	1712.4	3.00
1413	1732.6	3.13
1513	1752.6	3.05

Spectrum Plot of Worst Value
WCDMA

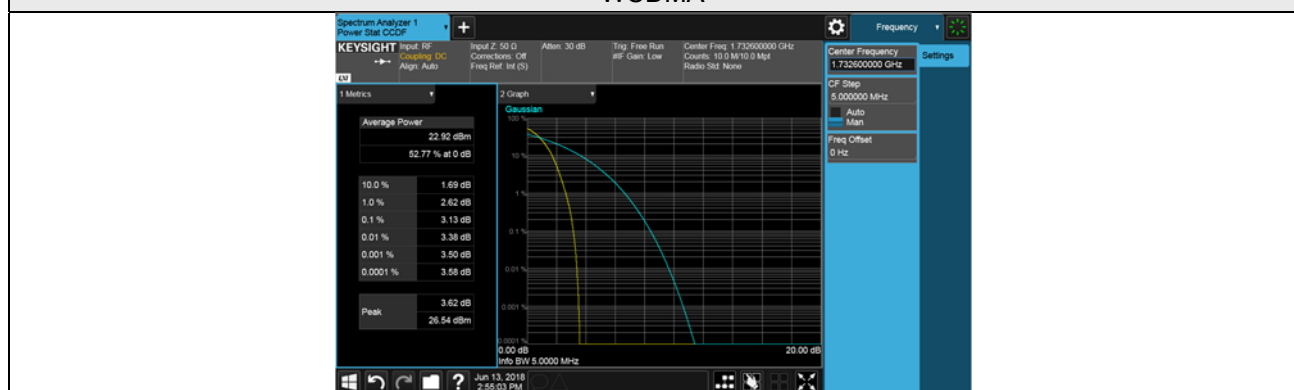

LTE Band 4

LTE Band 4, Channel Bandwidth: 1.4MHz				
Channel	Frequency (MHz)	Peak To Average Ratio (dB)		
		QPSK	16QAM	64QAM
19957	1710.7	5.04	5.03	4.89
20175	1732.5	5.04	5.02	5.02
20393	1754.3	4.96	4.95	5.02

LTE Band 4, Channel Bandwidth: 3MHz				
Channel	Frequency (MHz)	Peak To Average Ratio (dB)		
		QPSK	16QAM	64QAM
19965	1711.5	4.81	4.81	4.63
20175	1732.5	4.78	4.78	4.80
20385	1753.5	4.71	4.71	4.78

LTE Band 4, Channel Bandwidth: 5MHz				
Channel	Frequency (MHz)	Peak To Average Ratio (dB)		
		QPSK	16QAM	64QAM
19975	1712.5	4.78	4.67	4.75
20175	1732.5	4.94	4.93	4.94
20375	1752.5	4.95	4.96	4.79

LTE Band 4, Channel Bandwidth: 10MHz				
Channel	Frequency (MHz)	Peak To Average Ratio (dB)		
		QPSK	16QAM	64QAM
20000	1715.0	4.95	4.96	4.77
20175	1732.5	4.95	4.96	4.95
20350	1750.0	5.00	4.99	4.98

LTE Band 4, Channel Bandwidth: 15MHz				
Channel	Frequency (MHz)	Peak To Average Ratio (dB)		
		QPSK	16QAM	64QAM
20025	1717.5	4.89	4.89	4.69
20175	1732.5	4.87	4.87	4.86
20325	1747.5	4.91	4.91	4.92

LTE Band 4, Channel Bandwidth: 20MHz

Channel	Frequency (MHz)	Peak To Average Ratio (dB)		
		QPSK	16QAM	64QAM
20050	1720.0	4.84	4.83	4.75
20175	1732.5	4.83	4.82	4.80
20300	1745.0	4.87	4.88	4.87

Spectrum Plot Of Worst Value

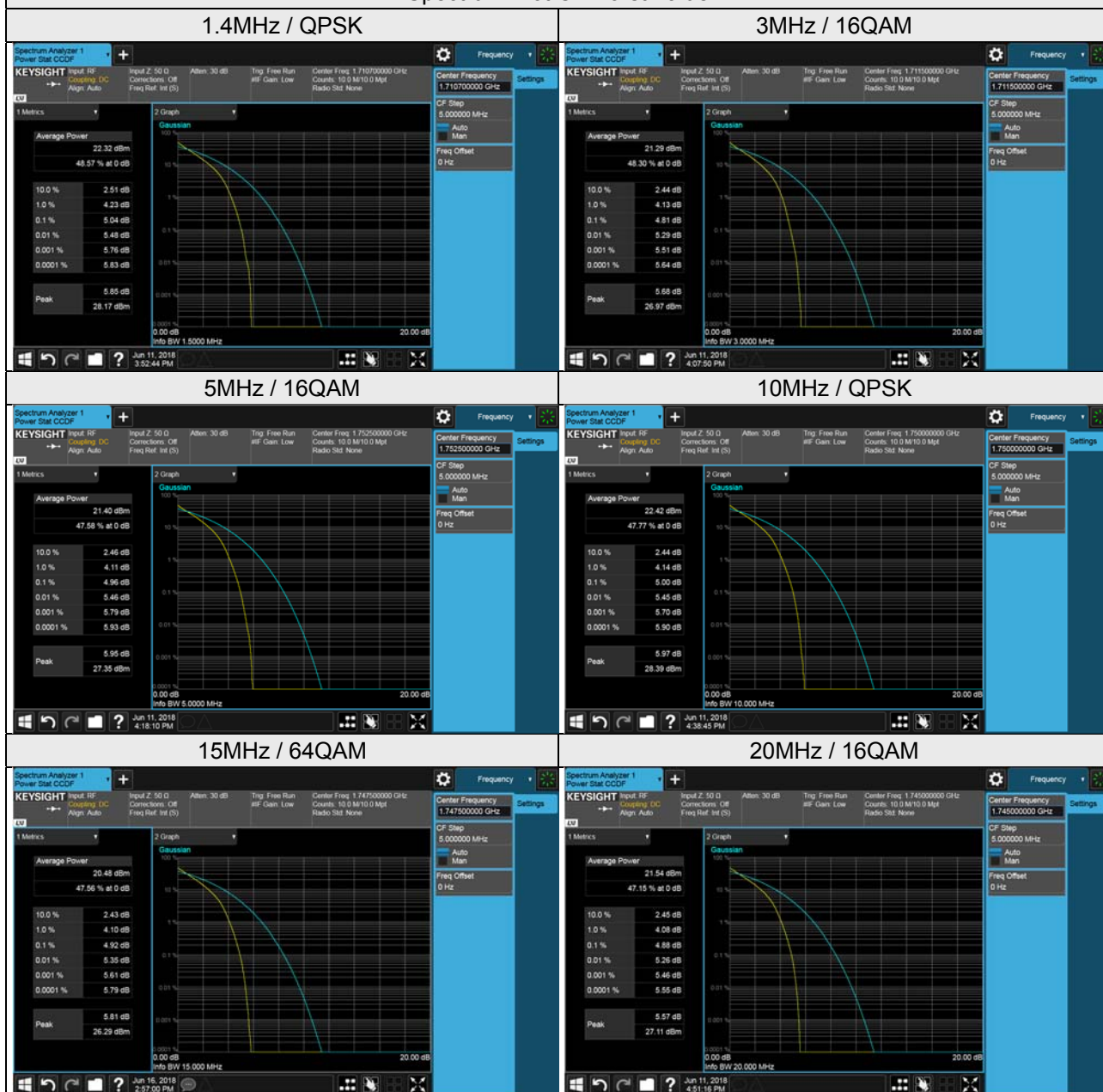

LTE Band 7, Channel Bandwidth: 5MHz				
Channel	Frequency (MHz)	Peak To Average Ratio (dB)		
		QPSK	16QAM	64QAM
20775	2502.5	4.96	4.96	4.96
21100	2535.0	4.93	4.94	4.95
21425	2567.5	4.94	4.95	4.96

LTE Band 7, Channel Bandwidth: 10MHz				
Channel	Frequency (MHz)	Peak To Average Ratio (dB)		
		QPSK	16QAM	64QAM
20800	2505.0	4.96	4.96	4.96
21100	2535.0	4.96	4.96	4.95
21400	2565.0	4.96	4.97	4.99

LTE Band 7, Channel Bandwidth: 15MHz				
Channel	Frequency (MHz)	Peak To Average Ratio (dB)		
		QPSK	16QAM	64QAM
20825	2507.5	4.98	4.98	5.02
21100	2535.0	4.93	4.91	4.91
21375	2562.5	4.96	4.96	4.97

LTE Band 7, Channel Bandwidth: 20MHz				
Channel	Frequency (MHz)	Peak To Average Ratio (dB)		
		QPSK	16QAM	64QAM
20850	2510.0	4.95	4.94	4.97
21100	2535.0	4.85	4.84	4.86
21350	2560.0	4.82	4.81	4.88

Spectrum Plot Of Worst Value

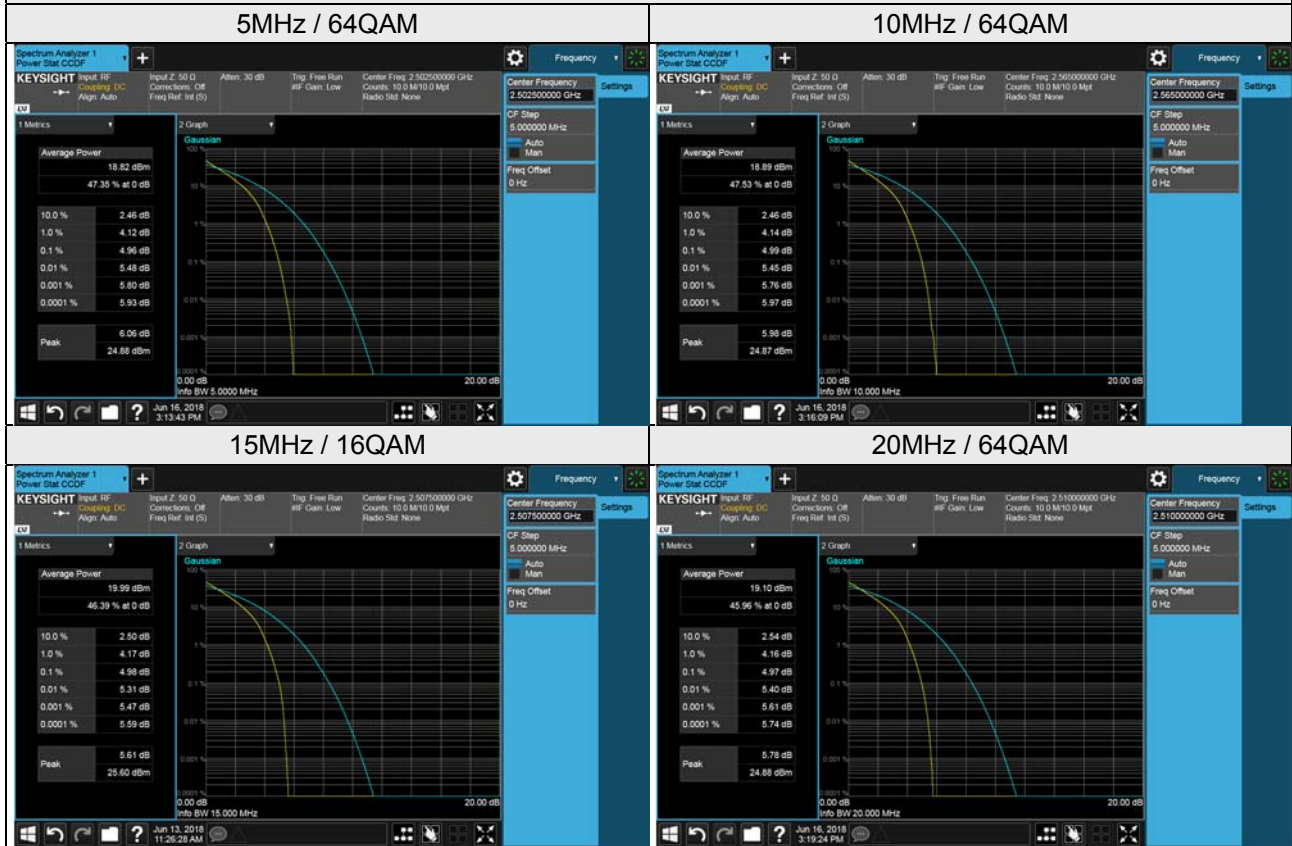

LTE Band 7, CA Mode, Channel Bandwidth: 20MHz+20MHz

Channel	Frequency (MHz)	Peak To Average Ratio (dB)	
		QPSK	
20850+21048	2510.0MHz+2529.8MHz	2.09	
21100+21298	2535.0MHz+2554.8MHz	1.81	
21350+21152	2560.0MHz+2540.2MHz	2.29	

Spectrum Plot Of Worst Value

20MHz+20MHz / QPSK

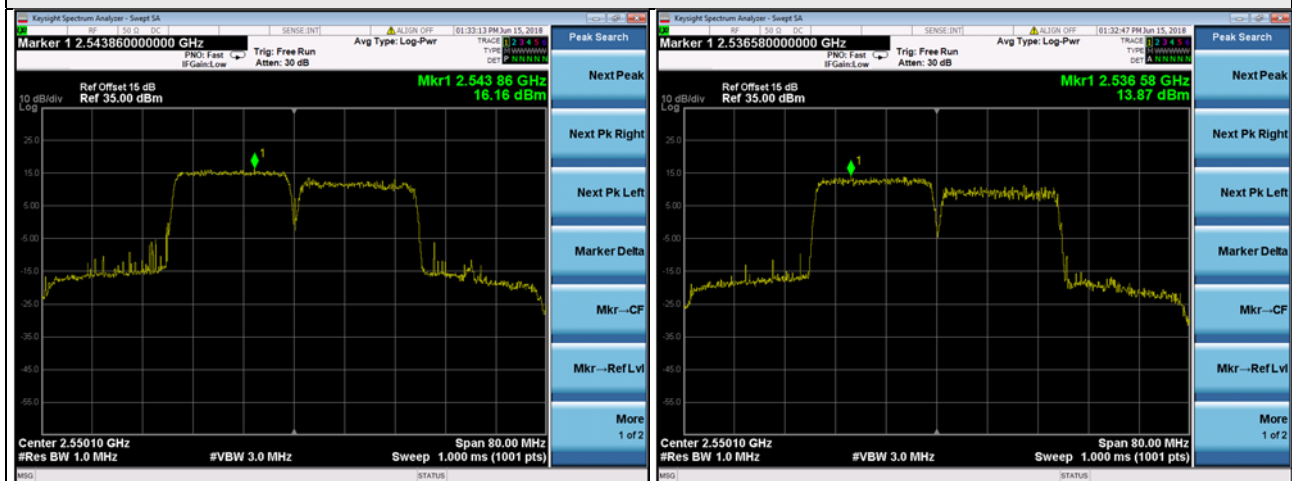

LTE Band 12, Channel Bandwidth: 1.4MHz

Channel	Frequency (MHz)	Peak To Average Ratio (dB)		
		QPSK	16QAM	64QAM
23017	699.7	4.98	4.99	4.99
23095	707.5	4.89	4.88	4.80
23173	715.3	4.98	4.97	5.05

LTE Band 12, Channel Bandwidth: 3MHz

Channel	Frequency (MHz)	Peak To Average Ratio (dB)		
		QPSK	16QAM	64QAM
23025	700.5	4.82	4.82	4.86
23095	707.5	4.72	4.72	4.67
23165	714.5	4.73	4.73	4.77

LTE Band 12, Channel Bandwidth: 5MHz

Channel	Frequency (MHz)	Peak To Average Ratio (dB)		
		QPSK	16QAM	64QAM
23035	701.5	4.99	5.00	4.97
23095	707.5	4.86	4.86	4.81
23155	713.5	4.95	4.94	4.98

LTE Band 12, Channel Bandwidth: 10MHz

Channel	Frequency (MHz)	Peak To Average Ratio (dB)		
		QPSK	16QAM	64QAM
23060	704.0	4.60	4.61	4.61
23095	707.5	4.93	4.94	4.92
23130	711.0	5.30	5.31	5.29

Spectrum Plot Of Worst Value

1.4MHz / 64QAM



3MHz / 64QAM

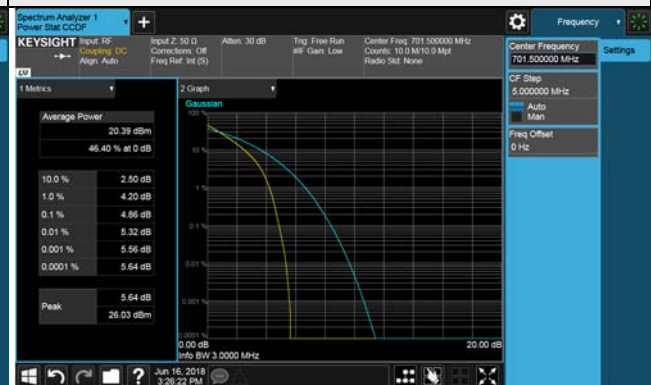

5MHz / 16QAM



10MHz / 16QAM

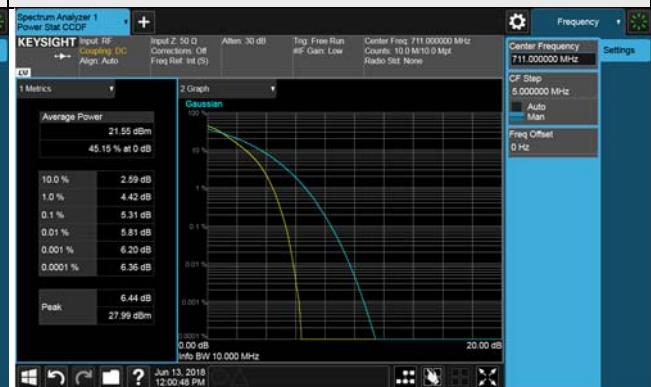

LTE Band 13, Channel Bandwidth: 5MHz

Channel	Frequency (MHz)	Peak To Average Ratio (dB)		
		QPSK	16QAM	64QAM
23205	779.5	4.89	4.89	4.89
23230	782.0	4.90	4.91	4.92
23255	784.5	4.92	4.92	4.90

LTE Band 13, Channel Bandwidth: 10MHz

Channel	Frequency (MHz)	Peak To Average Ratio (dB)		
		QPSK	16QAM	64QAM
23230	782.0	4.84	4.82	4.84

Spectrum Plot Of Worst Value

5MHz / 64QAM

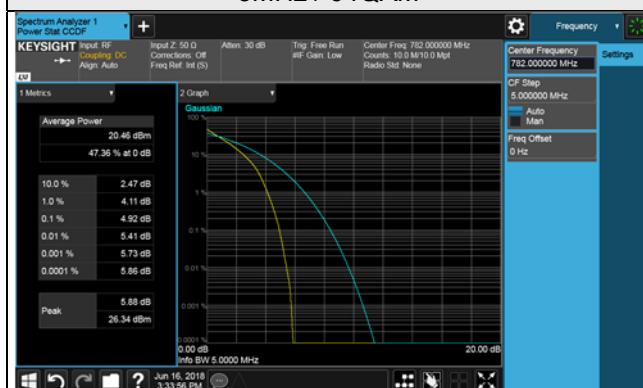

10MHz / 64QAM

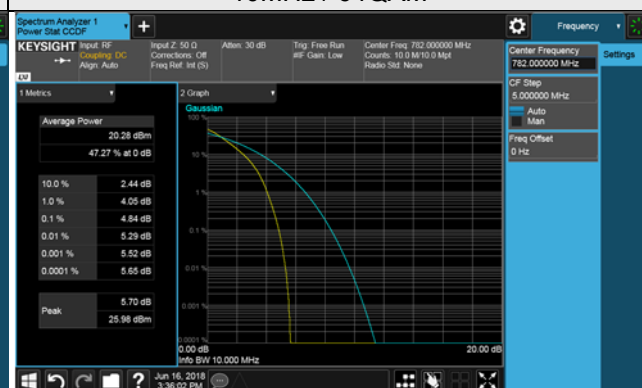

LTE Band 17, Channel Bandwidth: 5MHz

Channel	Frequency (MHz)	Peak To Average Ratio (dB)		
		QPSK	16QAM	64QAM
23755	706.5	4.79	4.78	4.78
23790	710.0	4.90	4.89	4.89
23825	713.5	4.97	4.98	4.98

LTE Band 17, Channel Bandwidth: 10MHz

Channel	Frequency (MHz)	Peak To Average Ratio (dB)		
		QPSK	16QAM	64QAM
23780	709.0	5.10	5.11	5.10
23790	710.0	5.22	5.20	5.22
23800	711.0	5.27	5.27	5.27

Spectrum Plot Of Worst Value

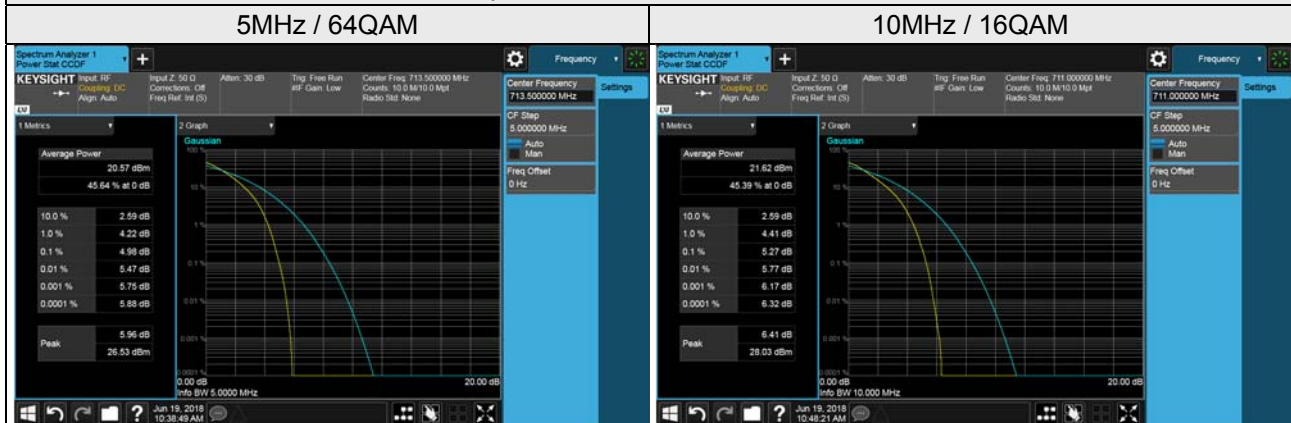

LTE Band 38, Channel Bandwidth: 5MHz				
Channel	Frequency (MHz)	Peak To Average Ratio (dB)		
		QPSK	16QAM	64QAM
37775	2572.5	4.88	4.88	4.88
38000	2595.0	4.88	4.88	4.88
38225	2617.5	4.90	4.89	4.90

LTE Band 38, Channel Bandwidth: 10MHz				
Channel	Frequency (MHz)	Peak To Average Ratio (dB)		
		QPSK	16QAM	64QAM
37800	2575.0	5.37	5.38	5.33
38000	2595.0	5.34	5.00	5.26
38200	2615.0	4.97	4.89	4.96

LTE Band 38, Channel Bandwidth: 15MHz				
Channel	Frequency (MHz)	Peak To Average Ratio (dB)		
		QPSK	16QAM	64QAM
37825	2577.5	5.39	5.21	5.34
38000	2595.0	5.28	5.27	5.26
38175	2612.5	5.26	5.25	5.28

LTE Band 38, Channel Bandwidth: 20MHz				
Channel	Frequency (MHz)	Peak To Average Ratio (dB)		
		QPSK	16QAM	64QAM
37850	2580.0	5.12	5.08	5.13
38000	2595.0	5.12	5.09	5.08
38150	2610.0	5.13	5.10	5.12

Spectrum Plot Of Worst Value

5MHz / 64QAM

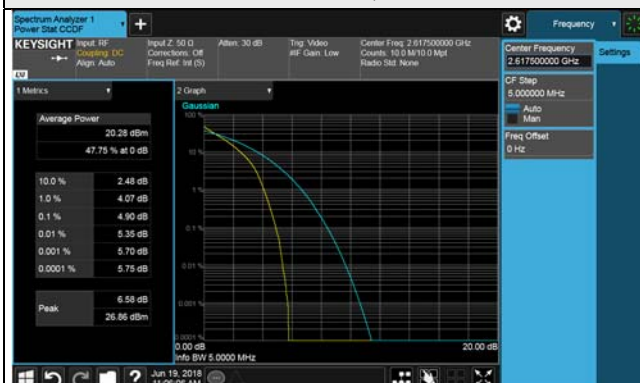

10MHz / 16QAM

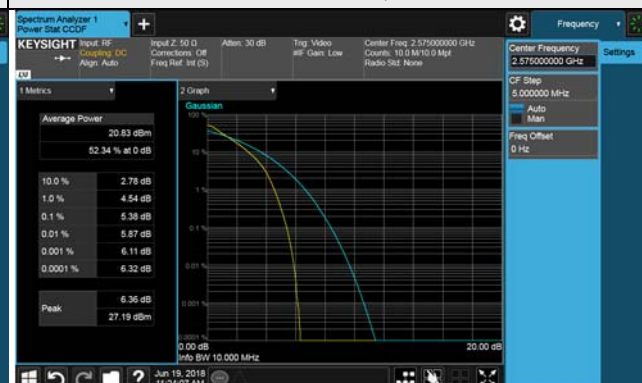

15MHz / QPSK

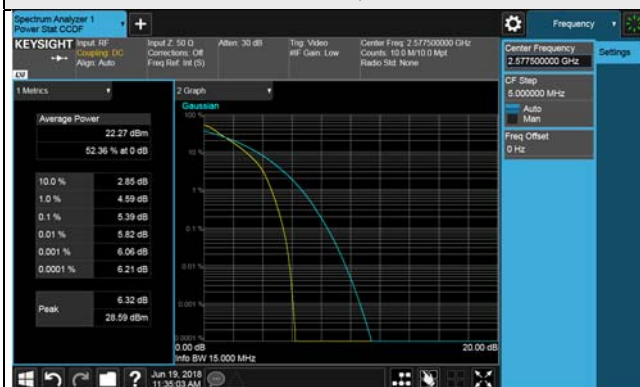

20MHz / QPSK

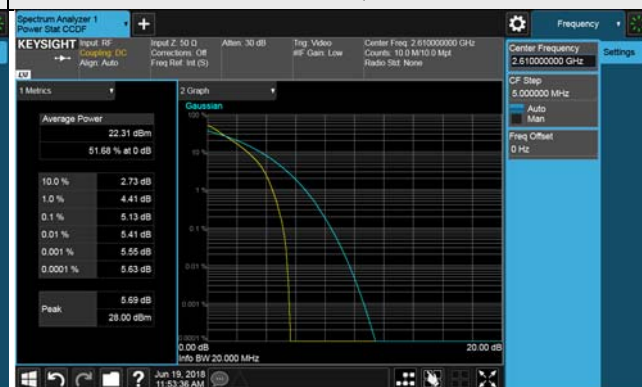

LTE Band 41, Channel Bandwidth: 5MHz				
Channel	Frequency (MHz)	Peak To Average Ratio (dB)		
		QPSK	16QAM	64QAM
40065	2537.5	5.08	5.27	5.20
40640	2595.0	5.33	5.36	5.32
41215	2652.5	5.34	5.29	5.26

LTE Band 41, Channel Bandwidth: 10MHz				
Channel	Frequency (MHz)	Peak To Average Ratio (dB)		
		QPSK	16QAM	64QAM
40090	2540.0	5.41	5.40	5.33
40640	2595.0	5.31	5.33	5.30
41190	2650.0	5.36	5.32	5.34

LTE Band 41, Channel Bandwidth: 15MHz				
Channel	Frequency (MHz)	Peak To Average Ratio (dB)		
		QPSK	16QAM	64QAM
40115	2542.5	5.26	5.35	5.25
40640	2595.0	5.23	5.26	5.29
41165	2647.5	5.29	5.35	5.31

LTE Band 41, Channel Bandwidth: 20MHz				
Channel	Frequency (MHz)	Peak To Average Ratio (dB)		
		QPSK	16QAM	64QAM
40140	2545.0	5.29	5.25	5.28
40640	2595.0	5.30	5.35	5.29
41140	2645.0	5.13	5.01	5.13

Spectrum Plot Of Worst Value

5MHz / 16QAM

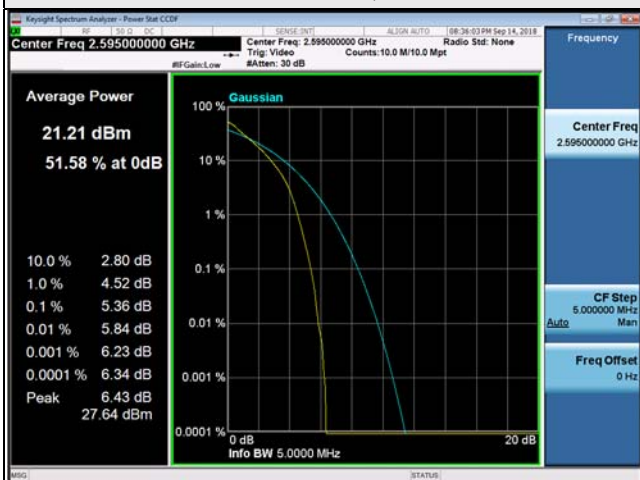

10MHz / QPSK

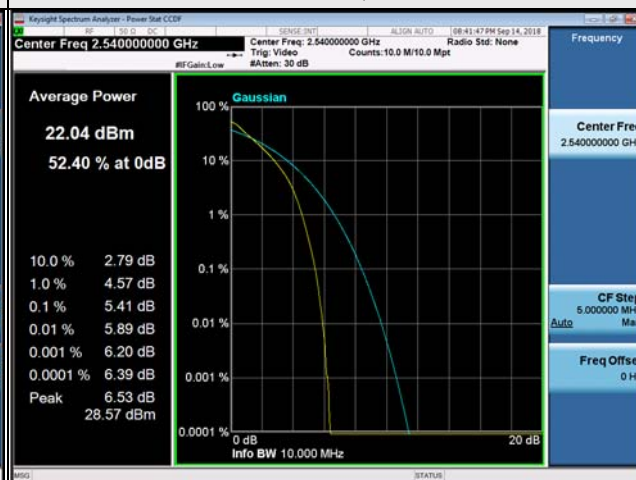

15MHz / 16QAM



20MHz / 16QAM

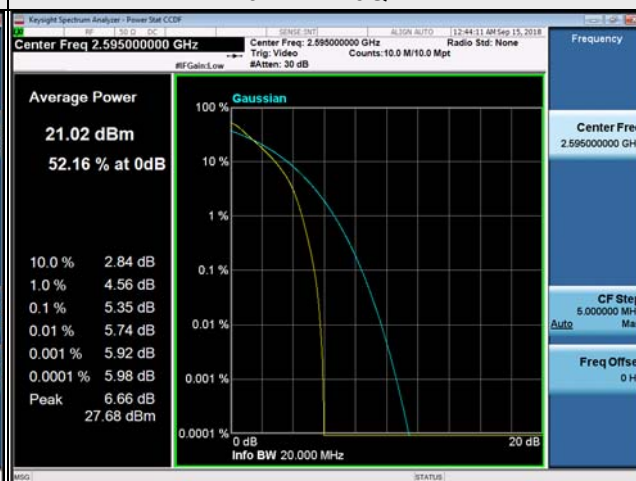

LTE Band 66, Channel Bandwidth: 1.4MHz				
Channel	Frequency (MHz)	Peak To Average Ratio (dB)		
		QPSK	16QAM	64QAM
131979	1710.7	5.06	5.05	4.85
132322	1745.0	5.10	5.09	5.04
132665	1779.3	5.09	5.07	5.04

LTE Band 66, Channel Bandwidth: 3MHz				
Channel	Frequency (MHz)	Peak To Average Ratio (dB)		
		QPSK	16QAM	64QAM
131987	1711.5	4.80	4.82	4.66
132322	1745.0	4.82	4.82	4.78
132657	1778.5	4.83	4.83	4.80

LTE Band 66, Channel Bandwidth: 5MHz				
Channel	Frequency (MHz)	Peak To Average Ratio (dB)		
		QPSK	16QAM	64QAM
131997	1712.5	4.93	4.94	4.79
132322	1745.0	4.95	4.94	4.86
132647	1777.5	4.94	4.95	4.88

LTE Band 66, Channel Bandwidth: 10MHz				
Channel	Frequency (MHz)	Peak To Average Ratio (dB)		
		QPSK	16QAM	64QAM
132022	1715.0	4.94	4.94	4.82
132322	1745.0	4.95	4.94	4.94
132622	1775.0	4.91	4.90	4.85

LTE Band 66, Channel Bandwidth: 15MHz				
Channel	Frequency (MHz)	Peak To Average Ratio (dB)		
		QPSK	16QAM	64QAM
132047	1717.5	4.79	4.79	4.74
132322	1745.0	4.92	4.93	4.92
132597	1772.5	4.77	4.79	4.66

LTE Band 66, Channel Bandwidth: 20MHz

Channel	Frequency (MHz)	Peak To Average Ratio (dB)		
		QPSK	16QAM	64QAM
132072	1720.0	4.83	4.83	4.73
132322	1745.0	4.85	4.86	4.83
132572	1770.0	4.82	4.82	4.77

Spectrum Plot Of Worst Value

