

FCC Test Report

Report No.: RF180523C10-10 R1

FCC ID: 2AJOTTA-1082

Test Model: TA-1082

Received Date: May 23, 2018

Test Date: Jun. 15, 2018

Issued Date: Oct. 24, 2018

Applicant: HMD Global Oy

Address: Bertel Jungin aukio 9, 02600 Espoo, Finland

Issued By: Bureau Veritas Consumer Products Services (H.K.) Ltd., Taoyuan Branch

Lab Address: No. 47-2, 14th Ling, Chia Pau Vil., Lin Kou Dist., New Taipei City, Taiwan
(R.O.C)

Test Location (1): No. 19, Hwa Ya 2nd Rd, Wen Hwa Tsuen, Kwei Shan Hsiang, Taoyuan
Hsien 333, Taiwan, R.O.C.

**FCC Registration /
Designation Number:** 788550 / TW0003



This report is for your exclusive use. Any copying or replication of this report to or for any other person or entity, or use of our name or trademark, is permitted only with our prior written permission. This report sets forth our findings solely with respect to the test samples identified herein. The results set forth in this report are not indicative or representative of the quality or characteristics of the lot from which a test sample was taken or any similar or identical product unless specifically and expressly noted. Our report includes all of the tests requested by you and the results thereof based upon the information that you provided to us. You have 60 days from date of issuance of this report to notify us of any material error or omission caused by our negligence, provided, however, that such notice shall be in writing and shall specifically address the issue you wish to raise. A failure to raise such issue within the prescribed time shall constitute your unqualified acceptance of the completeness of this report, the tests conducted and the correctness of the report contents. Unless specific mention, the uncertainty of measurement has been explicitly taken into account to declare the compliance or non-compliance to the specification. The report must not be used by the client to claim product certification, approval, or endorsement by TAF or any government agencies.

Table of Contents

Release Control Record	3
1 Certificate of Conformity	4
2 Summary of Test Results	5
2.1 Measurement Uncertainty.....	5
2.2 Modification Record	5
3 General Information	6
3.1 General Description of EUT	6
3.2 Description of Test Modes.....	7
3.2.1 Test Mode Applicability and Tested Channel Detail.....	7
3.3 Description of Support Units	8
3.3.1 Configuration of System under Test	8
3.4 General Description of Applied Standards.....	8
4 Test Types and Results	9
4.1 Radiated Emission and Bandedge Measurement	9
4.1.1 Limits of Radiated Emission and Bandedge Measurement	9
4.1.2 Test Instruments	10
4.1.3 Test Procedures.....	11
4.1.4 Deviation from Test Standard	11
4.1.5 Test Setup.....	12
4.1.6 EUT Operating Conditions.....	12
4.1.7 Test Results	13
5 Pictures of Test Arrangements	17
Appendix – Information on the Testing Laboratories	18
Annex A – Test Report for TA-1087 (Dual SIM)	19

Release Control Record

Issue No.	Description	Date Issued
RF180523C10-10	Original Release	Jul. 05, 2018
RF180523C10-10 R1	Revise applicant's address	Oct. 24, 2018



1 Certificate of Conformity

Product: Smart Phone
Brand: NOKIA
Test Model: TA-1082
Sample Status: Production Unit
Applicant: HMD Global Oy
Test Date: Jun. 15, 2018
Standards: 47 CFR FCC Part 15, Subpart C (Section 15.209)
ANSI C63.10: 2013

This report is issued as a supplementary report to BV CPS report no.: RF180523C09-10. This report shall be used by combining with its original report.

Prepared by :  , **Date:** Oct. 24, 2018
Ivonne Wu / Supervisor

Approved by :  , **Date:** Oct. 24, 2018
Dylan Chiou / Project Engineer

2 Summary of Test Results

47 CFR FCC Part 15, Subpart C (Section 15.209)			
FCC Clause	Test Item	Result	Remarks
15.207	Conducted emission test	N/A	Refer to Note
15.209	Radiated emission test	Pass	Meet the requirement of limit. Minimum passing margin is -2.31 dB at 71.69 MHz.

Note: Only radiated emissions test above 30 MHz had been performed for the addendum. Refer to original report for other test data.

2.1 Measurement Uncertainty

Where relevant, the following measurement uncertainty levels have been estimated for tests performed on the EUT as specified in CISPR 16-4-2:

Measurement	Frequency	Expanded Uncertainty (k=2) (±)
Radiated Emissions up to 1 GHz	30 MHz ~ 200 MHz	2.93 dB
	200 MHz ~ 1000 MHz	2.95 dB

2.2 Modification Record

There were no modifications required for compliance.

3 General Information

3.1 General Description of EUT

Product	Smart Phone
Brand	NOKIA
Test Model	TA-1082
Status of EUT	Production Unit
Power Supply Rating	5.0 Vdc or 9 Vdc or 12 Vdc (adapter) 5.0 Vdc (host equipment) 3.85 Vdc (Li-ion battery)
Operating Frequency	107 kHz
Antenna Connector	N/A
Accessory Device	Refer to Note as below
Data Cable Supplied	Refer to Note as below

Note:

1. This report is issued as a supplementary report to BV CPS report no.: RF180523C09-10. The difference is listed as below. Only radiated emission test above 30 MHz was verified in this report.

Report No.	FCC ID	Model	Difference
RF180523C09-10	2AJOTTA-1087	TA-1087	Dual SIM
RF180523C10-10	2AJOTTA-1082	TA-1082	Single SIM

* The models have the same layout, circuit, and components, but different SIM tray.

2. The EUT's accessories list refers to Ext. Pho.
3. The above EUT information is declared by manufacturer and for more detailed features description, please refers to the manufacturer's specifications or user's manual.

3.2 Description of Test Modes

1 channel is provided to this EUT:

Channel	Frequency (kHz)
1	107

3.2.1 Test Mode Applicability and Tested Channel Detail

EUT Configure Mode	Applicable To	Description
	RE<1G	
A	√	Charging Mode
B	√	Standby Mode

Where **RE<1G**: Radiated Emission below 1 GHz

Radiated Emission Test (Below 1 GHz):

- Pre-Scan has been conducted to determine the worst-case mode from all possible combinations between available modulations, data rates and antenna ports (if EUT with antenna diversity architecture).
- Following channel(s) was (were) selected for the final test as listed below.

EUT Configure Mode	Available Channel	Tested Channel
-	1	1

Test Condition:

Applicable To	Environmental Conditions	Input Power	Tested By
RE	25 deg. C, 65 % RH	120 Vac, 60 Hz	Jisyong Wang

3.3 Description of Support Units

The EUT has been tested as an independent unit together with other necessary accessories or support units. The following support units or accessories were used to form a representative test configuration during the tests.

No.	Product	Brand	Model No.	Serial No.	FCC ID
A.	WPC	Samsung	N/A	N/A	N/A

No.	Signal Cable Description Of The Above Support Units
1.	N/A

Note:

1. All power cords of the above support units are non-shielded (1.8m).

3.3.1 Configuration of System under Test

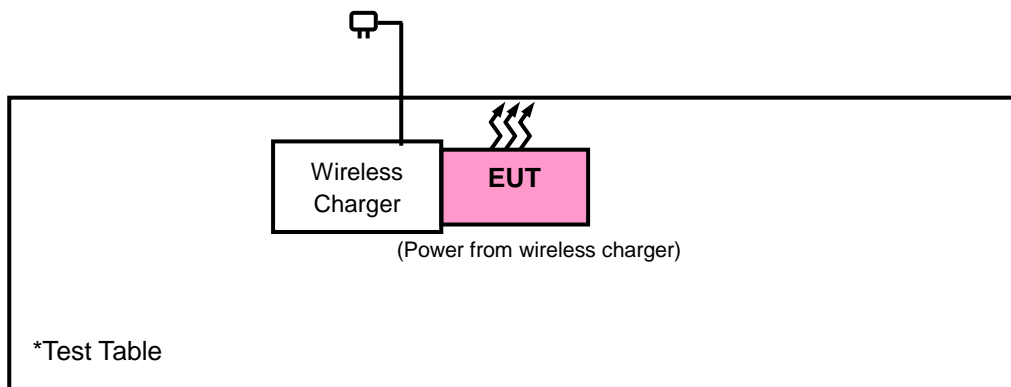

3.4 General Description of Applied Standards

The EUT is a RF Product. According to the specifications of the manufacturer, it must comply with the requirements of the following standards:

FCC Part 15, Subpart C (15.209)

ANSI C63.10-2013

All test items have been performed and recorded as per the above standards.

4 Test Types and Results

4.1 Radiated Emission and Bandedge Measurement

4.1.1 Limits of Radiated Emission and Bandedge Measurement

Frequencies (MHz)	Field Strength (microvolts/meter)	Measurement Distance (meters)
0.009 ~ 0.490	2400/F (kHz)	300
0.490 ~ 1.705	24000/F (kHz)	30
1.705 ~ 30.0	30	30
30 ~ 88	100	3
88 ~ 216	150	3
216 ~ 960	200	3
Above 960	500	3

NOTE:

1. The lower limit shall apply at the transition frequencies.
2. Emission level (dBuV/m) = 20 log Emission level (uV/m).
3. For frequencies above 1000 MHz, the field strength limits are based on average detector, however, the peak field strength of any emission shall not exceed the maximum permitted average limits, specified above by more than 20 dB under any condition of modulation.

4.1.2 Test Instruments

Description & Manufacturer	Model No.	Serial No.	Date of Calibration	Due Date of Calibration
Test Receiver Agilent	N9038A	MY51210203	Mar. 16, 2018	Mar. 15, 2019
Spectrum Analyzer Agilent	N9010A	MY52220314	Nov. 24, 2017	Nov. 23, 2018
Spectrum Analyzer ROHDE & SCHWARZ	FSU43	101261	Jan. 11, 2018	Jan. 10, 2019
Double Ridge Guide Horn Antenna EMCO	3115	5619	Nov. 30, 2017	Nov. 29, 2018
BILOG Antenna SCHWARZBECK	VULB 9168	9168-153	Dec. 06, 2017	Dec. 05, 2018
RF signal cable ETS-LINDGREN	5D-FB	Cable-RF1-01(RF C-SMS-100-SMS- 120+MY13379/4)	Jun. 20, 2018	Jun. 19, 2019
Loop Antenna	EM-6879	269	Aug. 11, 2017	Aug. 10, 2018
Preamplifier EMCI	EMC001340	980201	Nov. 01, 2017	Oct. 30, 2018
Preamplifier EMCI	EMC 012645	980115	Oct. 20, 2017	Oct. 19, 2018
Preamplifier EMCI	EMC 184045	980116	Oct. 20, 2017	Oct. 19, 2018
Preamplifier EMCI	EMC 330H	980112	Oct. 13, 2017	Oct. 12, 2018
RF Coaxial Cable HUBER+SUHNNER	EMC104-SM-SM-800 0&3000	140811+170717	Oct. 20, 2017	Oct. 19, 2018
RF Coaxial Cable HUBER+SUHNNER	SUCOFLEX 104	EMC104-SM-SM- 1000(140807)	Oct. 20, 2017	Oct. 19, 2018
RF Coaxial Cable Worken	8D-FB	Cable-Ch10-01	Oct. 20, 2017	Oct. 19, 2018
Boresight Antenna Fixture	FBA-01	FBA-SIP01	NA	NA
Software BV ADT	E3 6.120103	NA	NA	NA
Antenna Tower MF	MFA-440H	NA	NA	NA
Turn Table MF	MFT-201SS	NA	NA	NA
Antenna Tower & Turn Table Controller MF	MF-7802	NA	NA	NA

- Note: 1. The calibration interval of the above test instruments is 12 months and the calibrations are traceable to NML/ROC and NIST/USA.
2. The test was performed in HwaYa Chamber 10.
3. The horn antenna and preamplifier (model: EMC 184045) are used only for the measurement of emission frequency above 1GHz if tested.
4. The IC Site Registration No. is IC7450F-10.

4.1.3 Test Procedures

For Radiated Emission above 30 MHz

- a. The EUT was placed on the top of a rotating table 0.8 meters above the ground at 3 meter chamber room for test. The table was rotated 360 degrees to determine the position of the highest radiation.
- b. The EUT was set 3 meters away from the interference-receiving antenna, which was mounted on the top of a variable-height antenna tower.
- c. The height of antenna is varied from one meter to four meters above the ground to determine the maximum value of the field strength. Both horizontal and vertical polarizations of the antenna are set to make the measurement.
- d. For each suspected emission, the EUT was arranged to its worst case and then the antenna was tuned to heights from 1 meter to 4 meters and the rotatable table was turned from 0 degrees to 360 degrees to find the maximum reading.
- e. The test-receiver system was set to quasi-peak detect function and specified bandwidth with maximum hold mode when the test frequency is below 1 GHz.
- f. The test-receiver system was set to peak and average detected function and specified bandwidth with maximum hold mode when the test frequency is above 1 GHz. If the peak reading value also meets average limit, measurement with the average detector is unnecessary.

Note:

1. The resolution bandwidth and video bandwidth of test receiver/spectrum analyzer is 120 kHz for Quasi-peak detection (QP) at frequency below 1 GHz.
2. The resolution bandwidth of test receiver/spectrum analyzer is 1 MHz and the video bandwidth is 3 MHz for Peak detection (PK) at frequency above 1 GHz.
3. The resolution bandwidth of test receiver/spectrum analyzer is 1 MHz and the video bandwidth is $\geq 1/T$ (Duty cycle $< 98\%$) or 10 Hz (Duty cycle $\geq 98\%$) for Average detection (AV) at frequency above 1 GHz.
4. All modes of operation were investigated and the worst-case emissions are reported.

4.1.4 Deviation from Test Standard

No deviation.

4.1.5 Test Setup

<Radiated Emission 30 MHz to 1 GHz>

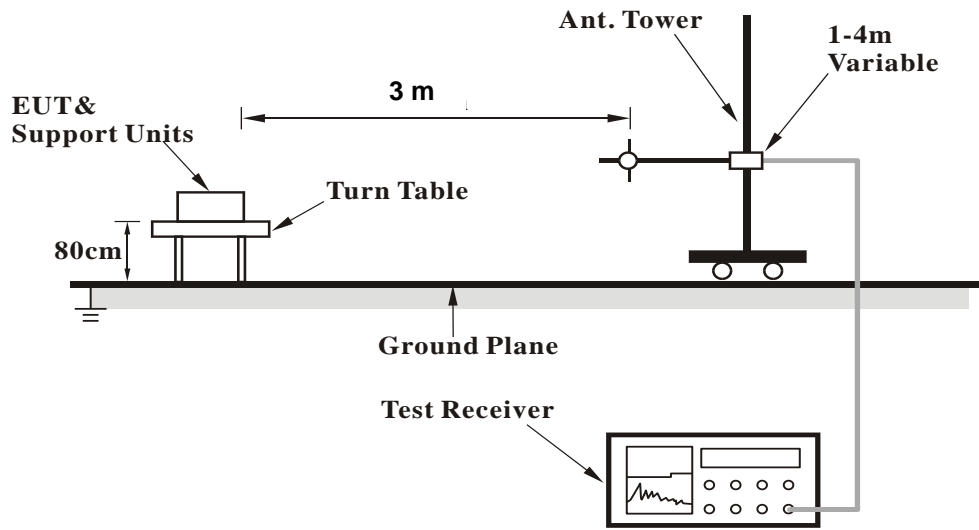

For the actual test configuration, please refer to the attached file (Test Setup Photo).

4.1.6 EUT Operating Conditions

Set the EUT under transmission condition continuously at specific channel frequency.

4.1.7 Test Results

<Charging Mode>

EUT Test Condition		Measurement Detail	
Input Power	120 Vac, 60 Hz	Frequency Range	30 MHz ~ 1000 MHz
Environmental Conditions	25 deg. C, 65 % RH	Detector Function	Peak
Tested By	Jisyong Wang		

Horizontal

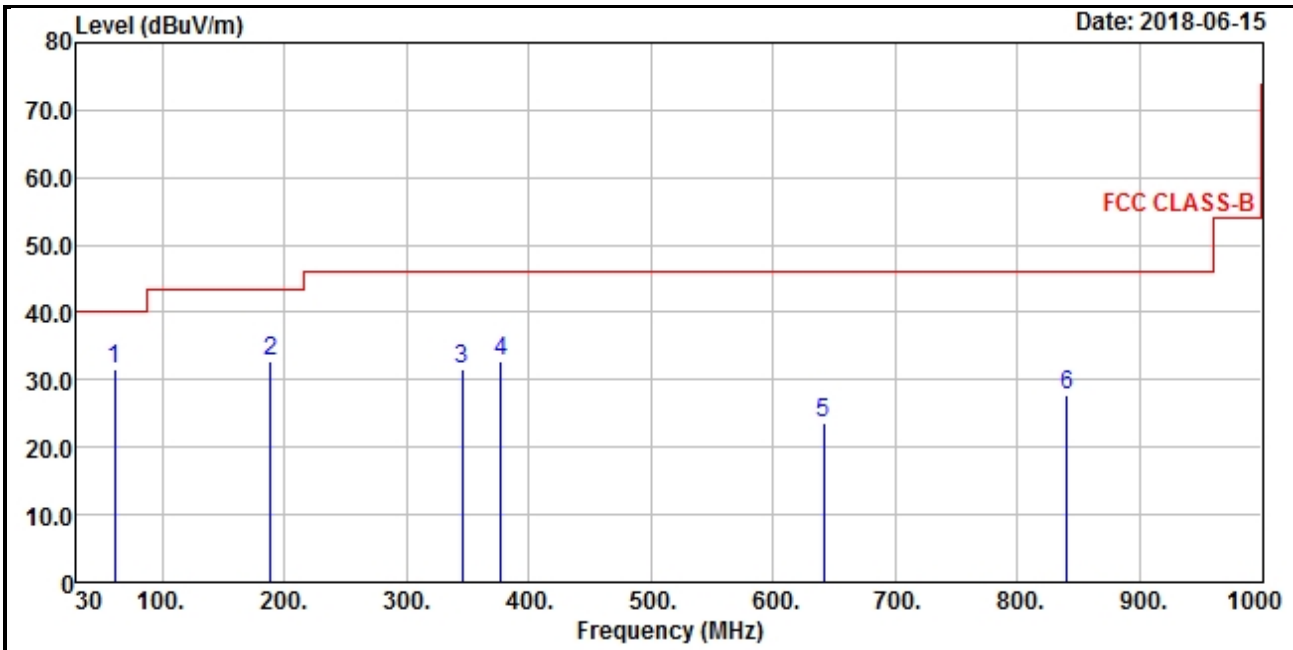

Vertical

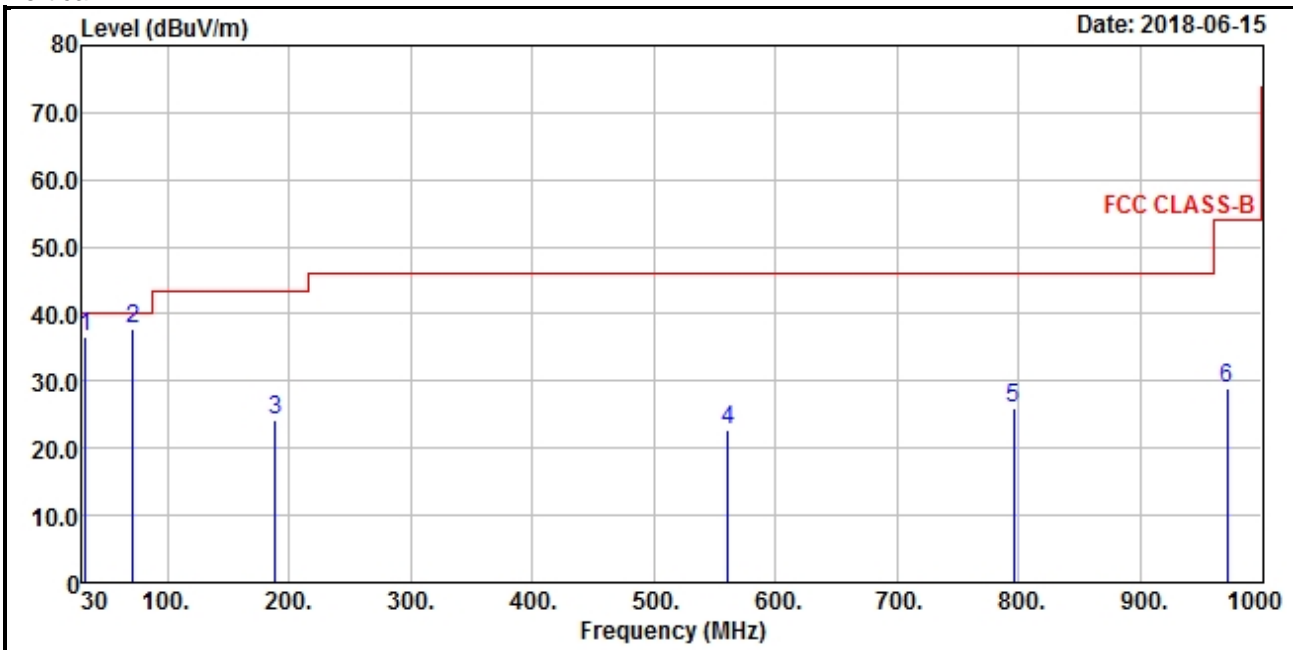

Antenna Polarity & Test Distance: Horizontal at 3 m

Frequency (MHz)	Emission Level (dBuV/m)	Read Level (dBuV)	Limit (dBuV/m)	Margin (dB)	Antenna Factor (dB/m)	Cable Loss (dB)	Preamp Factor (dB)	Antenna Height (cm)	Table Angle (Degree)	Remark
61.25	31.63	50.47	40	-8.37	11.94	0.58	31.36	185	295	Peak
188.65	32.63	52.89	43.5	-10.87	10.33	1.15	31.74	102	251	Peak
345.52	31.65	47.57	46	-14.35	14.05	1.86	31.83	132	256	Peak
377.65	32.69	47.87	46	-13.31	14.77	1.99	31.94	102	185	Peak
641.52	23.52	32.45	46	-22.48	20.09	3.07	32.09	110	252	Peak
840.52	27.69	32.95	46	-18.31	22.74	3.8	31.8	164	251	Peak

Antenna Polarity & Test Distance: Vertical at 3 m

Frequency (MHz)	Emission Level (dBuV/m)	Read Level (dBuV)	Limit (dBuV/m)	Margin (dB)	Antenna Factor (dB/m)	Cable Loss (dB)	Preamp Factor (dB)	Antenna Height (cm)	Table Angle (Degree)	Remark
32.62	36.52	54.88	40	-3.48	12.3	0.45	31.11	285	145	Peak
71.69	37.69	58.31	40	-2.31	10.53	0.64	31.79	102	295	Peak
188.45	24.25	44.65	43.5	-19.25	10.12	1.17	31.69	169	285	Peak
561.25	22.69	33.31	46	-23.31	18.7	2.74	32.06	132	256	Peak
795.52	26.01	31.82	46	-19.99	22	3.61	31.42	147	285	Peak
971.65	29.01	32.57	54	-24.99	23.92	4.34	31.82	132	256	Peak

Remarks:

1. Emission Level = Read Level + Antenna Factor + Cable Loss - Preamp Factor

Margin value = Emission level – Limit value.

<Standby Mode>

EUT Test Condition		Measurement Detail	
Input Power	120 Vac, 60 Hz	Frequency Range	30 MHz ~ 1000 MHz
Environmental Conditions	25 deg. C, 65 % RH	Detector Function	Peak
Tested By	Jisyong Wang		

Horizontal

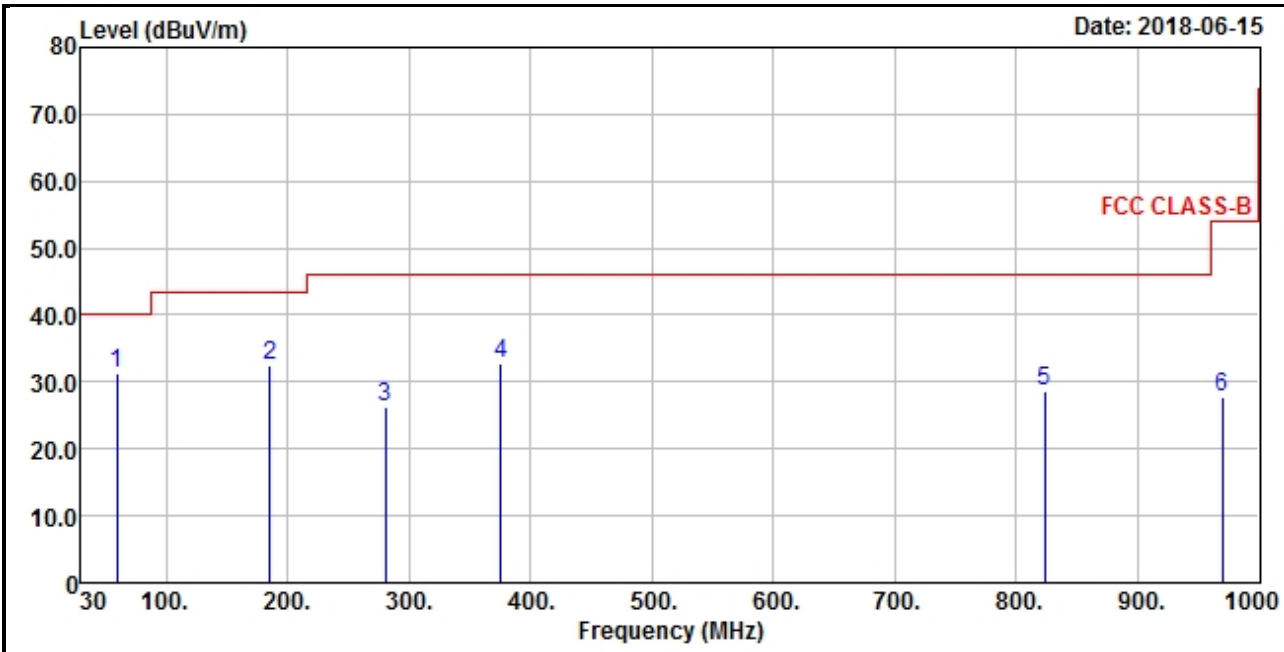

Vertical

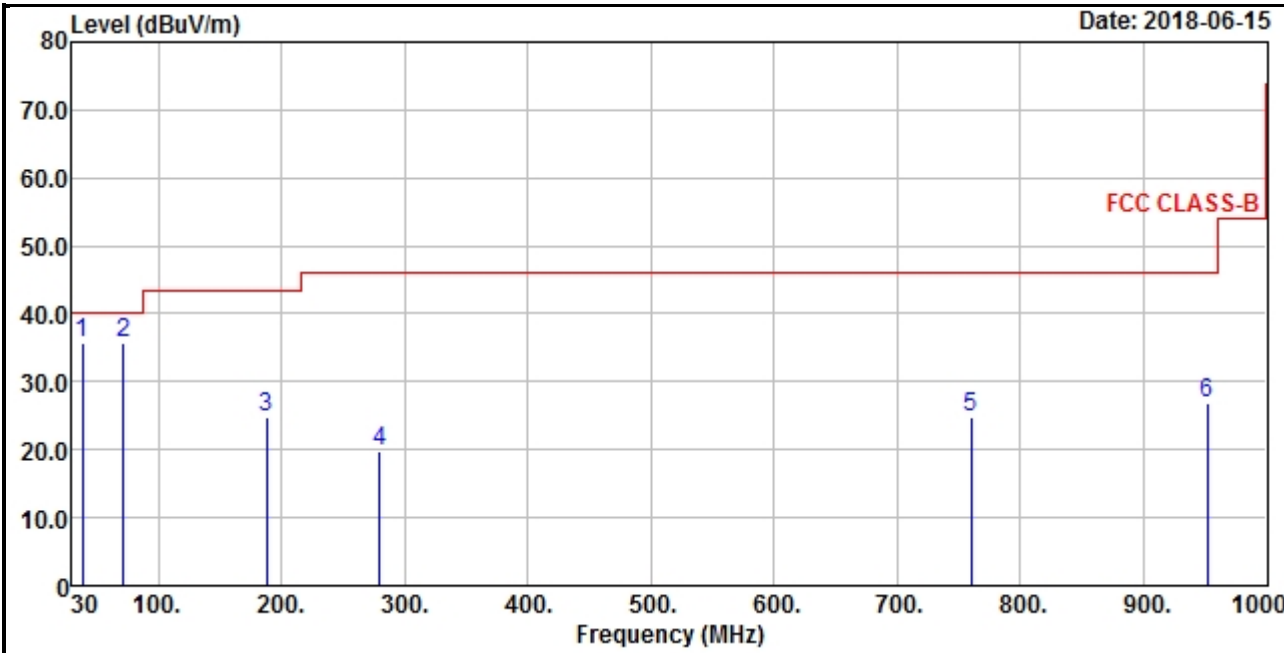



Antenna Polarity & Test Distance: Horizontal at 3 m

Frequency (MHz)	Emission Level (dBuV/m)	Read Level (dBuV)	Limit (dBuV/m)	Margin (dB)	Antenna Factor (dB/m)	Cable Loss (dB)	Preamp Factor (dB)	Antenna Height (cm)	Table Angle (Degree)	Remark
59.85	31.36	50.2	40	-8.64	11.94	0.58	31.36	121	281	Peak
185.69	32.54	52.8	43.5	-10.96	10.33	1.15	31.74	132	256	Peak
280.41	26.25	44.6	46	-19.75	12.11	1.53	31.99	186	258	Peak
375.25	32.69	47.87	46	-13.31	14.77	1.99	31.94	111	251	Peak
823.65	28.65	34.02	46	-17.35	22.5	3.75	31.62	165	285	Peak
969.52	27.65	31.31	54	-26.35	23.9	4.32	31.88	185	123	Peak

Antenna Polarity & Test Distance: Vertical at 3 m

Frequency (MHz)	Emission Level (dBuV/m)	Read Level (dBuV)	Limit (dBuV/m)	Margin (dB)	Antenna Factor (dB/m)	Cable Loss (dB)	Preamp Factor (dB)	Antenna Height (cm)	Table Angle (Degree)	Remark
38.52	35.69	52.82	40	-4.31	13.39	0.48	31	185	214	Peak
71.69	35.69	56.31	40	-4.31	10.53	0.64	31.79	111	165	Peak
188.24	24.69	45.09	43.5	-18.81	10.12	1.17	31.69	165	285	Peak
280.14	19.69	37.52	46	-26.31	12.4	1.58	31.81	147	185	Peak
759.69	24.69	30.93	46	-21.31	21.67	3.54	31.45	152	174	Peak
951.69	26.85	30.66	46	-19.15	23.79	4.22	31.82	125	145	Peak

Remarks:

1. Emission Level = Read Level + Antenna Factor + Cable Loss - Preamp Factor

Margin value = Emission level – Limit value.



5 Pictures of Test Arrangements

Please refer to the attached file (Test Setup Photo).

Appendix – Information on the Testing Laboratories

We, Bureau Veritas Consumer Products Services (H.K.) Ltd., Taoyuan Branch, were founded in 1988 to provide our best service in EMC, Radio, Telecom and Safety consultation. Our laboratories are FCC recognized accredited test firms and accredited according to ISO/IEC 17025.

If you have any comments, please feel free to contact us at the following:

Linko EMC/RF Lab

Tel: 886-2-26052180

Fax: 886-2-26051924

Hsin Chu EMC/RF/Telecom Lab

Tel: 886-3-6668565

Fax: 886-3-6668323

Hwa Ya EMC/RF/Safety Lab

Tel: 886-3-3183232

Fax: 886-3-3270892

Email: service.adt@tw.bureauveritas.com

Web Site: www.bureauveritas-adt.com

The address and road map of all our labs can be found in our web site also.

--- END ---



Annex A – Test Report for TA-1087 (Dual SIM)

FCC Test Report

Report No.: RF180523C09-10 R1

FCC ID: 2AJOTTA-1087

Test Model: TA-1087

Received Date: May 23, 2018

Test Date: Jun. 11, 2018 ~ Jun. 19, 2018

Issued Date: Oct. 24, 2018

Applicant: HMD Global Oy

Address: Bertel Jungin aukio 9, 02600 Espoo, Finland

Issued By: Bureau Veritas Consumer Products Services (H.K.) Ltd., Taoyuan Branch

Lab Address: No. 47-2, 14th Ling, Chia Pau Vil., Lin Kou Dist., New Taipei City, Taiwan (R.O.C)

Test Location (1): No. 19, Hwa Ya 2nd Rd, Wen Hwa Tsuen, Kwei Shan Hsiang, Taoyuan Hsien 333, Taiwan, R.O.C.

**FCC Registration /
Designation Number:** 788550 / TW0003



This report is for your exclusive use. Any copying or replication of this report to or for any other person or entity, or use of our name or trademark, is permitted only with our prior written permission. This report sets forth our findings solely with respect to the test samples identified herein. The results set forth in this report are not indicative or representative of the quality or characteristics of the lot from which a test sample was taken or any similar or identical product unless specifically and expressly noted. Our report includes all of the tests requested by you and the results thereof based upon the information that you provided to us. You have 60 days from date of issuance of this report to notify us of any material error or omission caused by our negligence, provided, however, that such notice shall be in writing and shall specifically address the issue you wish to raise. A failure to raise such issue within the prescribed time shall constitute your unqualified acceptance of the completeness of this report, the tests conducted and the correctness of the report contents. Unless specific mention, the uncertainty of measurement has been explicitly taken into account to declare the compliance or non-compliance to the specification. The report must not be used by the client to claim product certification, approval, or endorsement by TAF or any government agencies.

Table of Contents

Release Control Record	3
1 Certificate of Conformity	4
2 Summary of Test Results.....	5
2.1 Measurement Uncertainty.....	5
2.2 Modification Record	5
3 General Information	6
3.1 General Description of EUT	6
3.2 Description of Test Modes.....	7
3.2.1 Test Mode Applicability and Tested Channel Detail.....	7
3.3 Description of Support Units	8
3.3.1 Configuration of System under Test	8
3.4 General Description of Applied Standards.....	8
4 Test Types and Results	9
4.1 Radiated Emission and Bandedge Measurement	9
4.1.1 Limits of Radiated Emission and Bandedge Measurement	9
4.1.2 Test Instruments	10
4.1.3 Test Procedures.....	11
4.1.4 Deviation from Test Standard	11
4.1.5 Test Setup.....	12
4.1.6 EUT Operating Conditions.....	12
4.1.7 Test Results	13
4.2 Conducted Emission Measurement.....	19
4.2.1 Limits of Conducted Emission Measurement	19
4.2.2 Test Instruments	19
4.2.3 Test Procedures.....	20
4.2.4 Deviation from Test Standard	21
4.2.5 Test Setup.....	21
4.2.6 EUT Operating Conditions.....	21
4.2.7 Test Results	22
5 Pictures of Test Arrangements.....	24
Appendix – Information on the Testing Laboratories	25

Release Control Record

Issue No.	Description	Date Issued
RF180523C09-10	Original Release	Jun. 28, 2018
RF180523C09-10 R1	Revise applicant's address	Oct. 24, 2018



A D T

1 Certificate of Conformity

Product: Smart Phone

Brand: NOKIA

Test Model: TA-1087

Sample Status: Production Unit

Applicant: HMD Global Oy

Test Date: Jun. 11, 2018 ~ Jun. 19, 2018

Standards: 47 CFR FCC Part 15, Subpart C (Section 15.209)
ANSI C63.10: 2013

The above equipment has been tested by **Bureau Veritas Consumer Products Services (H.K.) Ltd., Taoyuan Branch**, and found compliance with the requirement of the above standards. The test record, data evaluation & Equipment Under Test (EUT) configurations represented herein are true and accurate accounts of the measurements of the sample's RF characteristics under the conditions specified in this report.

Prepared by :

Date:

Oct. 24, 2018

Ivonne Wu / Supervisor

Approved by :

Date:

Oct. 24, 2018

Dylan Chiou / Project Engineer

2 Summary of Test Results

47 CFR FCC Part 15, Subpart C (Section 15.209)			
FCC Clause	Test Item	Result	Remarks
15.207	Conducted emission test	Pass	Meet the requirement of limit. Minimum passing margin is -14.4 dB at 16.37259 MHz.
15.209	Radiated emission test	Pass	Meet the requirement of limit. Minimum passing margin is -1.48 dB at 70.74 MHz.

2.1 Measurement Uncertainty

Where relevant, the following measurement uncertainty levels have been estimated for tests performed on the EUT as specified in CISPR 16-4-2:

Measurement	Frequency	Expanded Uncertainty (k=2) (±)
Conducted Emissions at mains ports	150 kHz ~ 30 MHz	2.44 dB
Radiated Emissions up to 1 GHz	30 MHz ~ 200 MHz	2.93 dB
	200 MHz ~ 1000 MHz	2.95 dB

2.2 Modification Record

There were no modifications required for compliance.

3 General Information

3.1 General Description of EUT

Product	Smart Phone
Brand	NOKIA
Test Model	TA-1087
Status of EUT	Production Unit
Power Supply Rating	5.0 Vdc or 9 Vdc or 12 Vdc (adapter) 5.0 Vdc (host equipment) 3.85 Vdc (Li-ion battery)
Operating Frequency	107 kHz
Antenna Connector	N/A
Accessory Device	Refer to Note as below
Data Cable Supplied	Refer to Note as below

Note:

1. The EUT's accessories list refers to Ext. Pho.
2. The above EUT information is declared by manufacturer and for more detailed features description, please refers to the manufacturer's specifications or user's manual.

3.2 Description of Test Modes

1 channel is provided to this EUT:

Channel	Frequency (kHz)
1	107

3.2.1 Test Mode Applicability and Tested Channel Detail

EUT Configure Mode	Applicable To		Description
	RE<1G	PLC	
A	√	√	Charging Mode
B	√	-	Standby Mode

Where **RE<1G**: Radiated Emission below 1 GHz **PLC**: Power Line Conducted Emission

Radiated Emission Test (Below 1 GHz):

- Pre-Scan has been conducted to determine the worst-case mode from all possible combinations between available modulations, data rates and antenna ports (if EUT with antenna diversity architecture).
- Following channel(s) was (were) selected for the final test as listed below.

EUT Configure Mode	Available Channel	Tested Channel
A, B	1	1

Power Line Conducted Emission Test:

- Pre-Scan has been conducted to determine the worst-case mode from all possible combinations between available modulations, data rates and antenna ports (if EUT with antenna diversity architecture).
- Following channel(s) was (were) selected for the final test as listed below.

EUT Configure Mode	Available Channel	Tested Channel
A	1	1

Test Condition:

Applicable To	Environmental Conditions	Input Power	Tested By
RE	25 deg. C, 65 % RH	120 Vac, 60 Hz	Jisyong Wang
PLC	25 deg. C, 65 % RH	120 Vac, 60 Hz	Jisyong Wang

3.3 Description of Support Units

The EUT has been tested as an independent unit together with other necessary accessories or support units. The following support units or accessories were used to form a representative test configuration during the tests.

No.	Product	Brand	Model No.	Serial No.	FCC ID
A.	WPC	Samsung	N/A	N/A	N/A

No.	Signal Cable Description Of The Above Support Units
1.	N/A

Note:

1. All power cords of the above support units are non-shielded (1.8m).

3.3.1 Configuration of System under Test

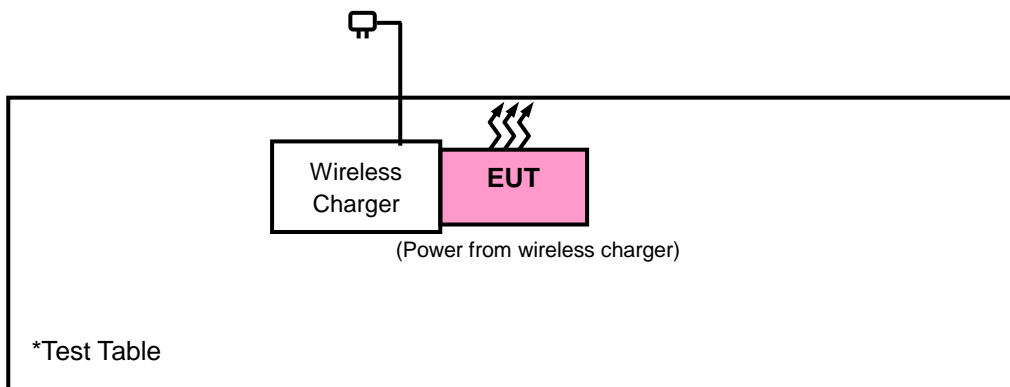

3.4 General Description of Applied Standards

The EUT is a RF Product. According to the specifications of the manufacturer, it must comply with the requirements of the following standards:

FCC Part 15, Subpart C (15.209)

ANSI C63.10-2013

All test items have been performed and recorded as per the above standards.

4 Test Types and Results

4.1 Radiated Emission and Bandedge Measurement

4.1.1 Limits of Radiated Emission and Bandedge Measurement

Frequencies (MHz)	Field Strength (microvolts/meter)	Measurement Distance (meters)
0.009 ~ 0.490	2400/F (kHz)	300
0.490 ~ 1.705	24000/F (kHz)	30
1.705 ~ 30.0	30	30
30 ~ 88	100	3
88 ~ 216	150	3
216 ~ 960	200	3
Above 960	500	3

NOTE:

1. The lower limit shall apply at the transition frequencies.
2. Emission level (dBuV/m) = 20 log Emission level (uV/m).
3. For frequencies above 1000 MHz, the field strength limits are based on average detector, however, the peak field strength of any emission shall not exceed the maximum permitted average limits, specified above by more than 20 dB under any condition of modulation.

4.1.2 Test Instruments

Description & Manufacturer	Model No.	Serial No.	Date of Calibration	Due Date of Calibration
Test Receiver Agilent	N9038A	MY51210203	Mar. 16, 2018	Mar. 15, 2019
Spectrum Analyzer Agilent	N9010A	MY52220314	Nov. 24, 2017	Nov. 23, 2018
Spectrum Analyzer ROHDE & SCHWARZ	FSU43	101261	Jan. 11, 2018	Jan. 10, 2019
Double Ridge Guide Horn Antenna EMCO	3115	5619	Nov. 30, 2017	Nov. 29, 2018
BILOG Antenna SCHWARZBECK	VULB 9168	9168-153	Dec. 06, 2017	Dec. 05, 2018
RF signal cable ETS-LINDGREN	5D-FB	Cable-CH1-01(RF C-SMS-100-SMS- 120+RFC-SMS-1 00-SMS-400)	Jun. 23, 2017	Jun. 22, 2018
Loop Antenna	EM-6879	269	Aug. 11, 2017	Aug. 10, 2018
Preamplifier EMCI	EMC001340	980201	Nov. 01, 2017	Oct. 30, 2018
Preamplifier EMCI	EMC 012645	980115	Oct. 20, 2017	Oct. 19, 2018
Preamplifier EMCI	EMC 184045	980116	Oct. 20, 2017	Oct. 19, 2018
Preamplifier EMCI	EMC 330H	980112	Oct. 13, 2017	Oct. 12, 2018
RF Coaxial Cable HUBER+SUHNNER	EMC104-SM-SM-800 0&3000	140811+170717	Oct. 20, 2017	Oct. 19, 2018
RF Coaxial Cable HUBER+SUHNNER	SUCOFLEX 104	EMC104-SM-SM- 1000(140807)	Oct. 20, 2017	Oct. 19, 2018
RF Coaxial Cable Worken	8D-FB	Cable-Ch10-01	Oct. 20, 2017	Oct. 19, 2018
Boresight Antenna Fixture	FBA-01	FBA-SIP01	NA	NA
Software BV ADT	E3 6.120103	NA	NA	NA
Antenna Tower MF	MFA-440H	NA	NA	NA
Turn Table MF	MFT-201SS	NA	NA	NA
Antenna Tower & Turn Table Controller MF	MF-7802	NA	NA	NA

- Note: 1. The calibration interval of the above test instruments is 12 months and the calibrations are traceable to NML/ROC and NIST/USA.
2. The test was performed in HwaYa Chamber 10.
3. The horn antenna and preamplifier (model: EMC 184045) are used only for the measurement of emission frequency above 1GHz if tested.
4. The IC Site Registration No. is IC7450F-10.

4.1.3 Test Procedures

For Radiated Emission below 30 MHz

- a. The EUT was placed on the top of a rotating table 0.8 meters above the ground at a 3 meter chamber room. The table was rotated 360 degrees to determine the position of the highest radiation.
- b. The EUT was set 3 meters away from the interference-receiving antenna, which was mounted on the top of a variable-height antenna tower.
- c. Both Parallel, perpendicular, and ground-parallel orientations of the antenna are set to make the measurement.
- d. For each suspected emission, the EUT was arranged to its worst case and the rotatable table was turned from 0 degrees to 360 degrees to find the maximum reading.
- e. The test-receiver system was set to Quasi-Peak Detect Function and Specified Bandwidth with Maximum Hold Mode.

Note:

1. The resolution bandwidth and video bandwidth of test receiver/spectrum analyzer is 9 kHz at frequency below 30 MHz.

For Radiated Emission above 30 MHz

- a. The EUT was placed on the top of a rotating table 0.8 meters above the ground at 3 meter chamber room for test. The table was rotated 360 degrees to determine the position of the highest radiation.
- b. The EUT was set 3 meters away from the interference-receiving antenna, which was mounted on the top of a variable-height antenna tower.
- c. The height of antenna is varied from one meter to four meters above the ground to determine the maximum value of the field strength. Both horizontal and vertical polarizations of the antenna are set to make the measurement.
- d. For each suspected emission, the EUT was arranged to its worst case and then the antenna was tuned to heights from 1 meter to 4 meters and the rotatable table was turned from 0 degrees to 360 degrees to find the maximum reading.
- e. The test-receiver system was set to quasi-peak detect function and specified bandwidth with maximum hold mode when the test frequency is below 1 GHz.
- f. The test-receiver system was set to peak and average detected function and specified bandwidth with maximum hold mode when the test frequency is above 1 GHz. If the peak reading value also meets average limit, measurement with the average detector is unnecessary.

Note:

1. The resolution bandwidth and video bandwidth of test receiver/spectrum analyzer is 120 kHz for Quasi-peak detection (QP) at frequency below 1 GHz.
2. The resolution bandwidth of test receiver/spectrum analyzer is 1 MHz and the video bandwidth is 3 MHz for Peak detection (PK) at frequency above 1 GHz.
3. The resolution bandwidth of test receiver/spectrum analyzer is 1 MHz and the video bandwidth is $\geq 1/T$ (Duty cycle $< 98\%$) or 10 Hz (Duty cycle $\geq 98\%$) for Average detection (AV) at frequency above 1 GHz.
4. All modes of operation were investigated and the worst-case emissions are reported.

4.1.4 Deviation from Test Standard

No deviation.

4.1.5 Test Setup

<Radiated Emission below 30 MHz>

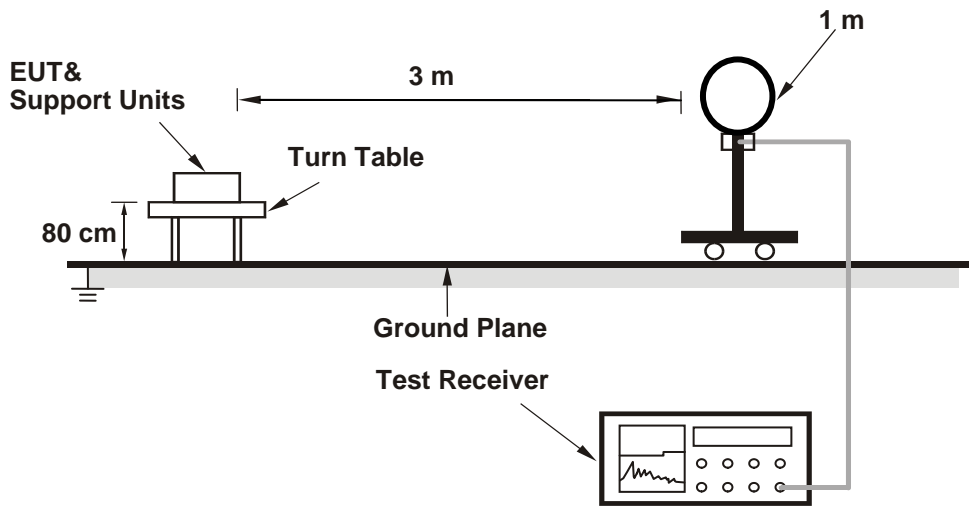

<Radiated Emission 30 MHz to 1 GHz>

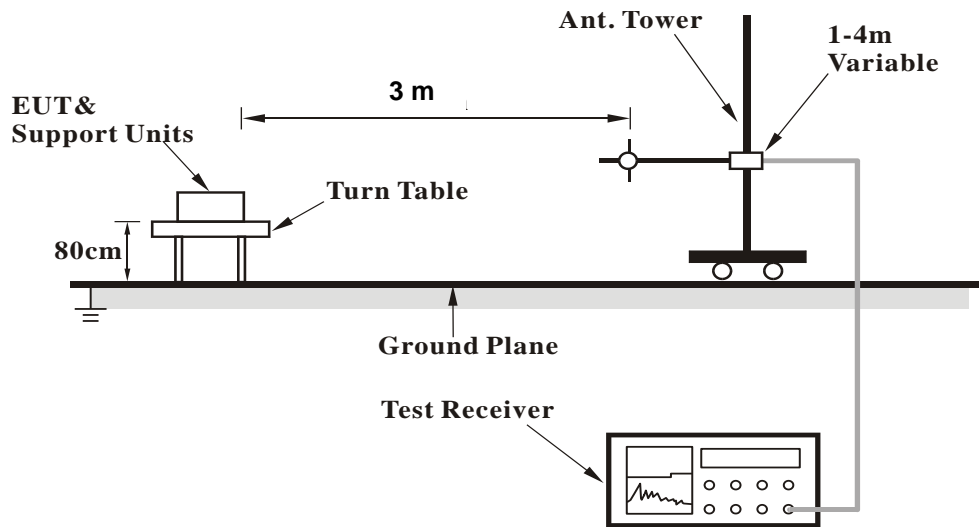

For the actual test configuration, please refer to the attached file (Test Setup Photo).

4.1.6 EUT Operating Conditions

Set the EUT under transmission condition continuously at specific channel frequency.

4.1.7 Test Results

<Charging Mode>

EUT Test Condition		Measurement Detail	
Input Power	120 Vac, 60 Hz	Frequency Range	0.009 ~ 30 MHz
Environmental Conditions	25 deg. C, 65 % RH	Detector Function	Average Quasi-Peak
Tested By	Jisyong Wang		

Antenna Polarity & Test Distance: Open at 3 m										
Frequency (MHz)	Emission Level (dBuV/m)	Read Level (dBuV)	Limit (dBuV/m)	Margin (dB)	Antenna Factor (dB/m)	Cable Loss (dB)	Preamp Factor (dB)	Antenna Height (cm)	Table Angle (Degree)	Remark
0.107	87.32	70.98	107.02	-19.7	57.35	0.02	41.03	100	360	QP
0.214	62.36	51.72	101	-38.64	51.49	0.02	40.87	100	360	Average
0.321	48.09	40.68	97.47	-49.38	48.15	0.03	40.77	100	360	Average
0.428	39.99	34.54	94.98	-54.99	46.09	0.05	40.69	100	360	Average
0.535	36.34	32.34	73.04	-36.7	44.59	0.07	40.66	100	360	QP
0.642	33.31	30.48	71.45	-38.14	43.42	0.09	40.68	100	360	QP

Antenna Polarity & Test Distance: Close at 3 m										
Frequency (MHz)	Emission Level (dBuV/m)	Read Level (dBuV)	Limit (dBuV/m)	Margin (dB)	Antenna Factor (dB/m)	Cable Loss (dB)	Preamp Factor (dB)	Antenna Height (cm)	Table Angle (Degree)	Remark
0.107	88.44	72.1	107.02	-18.58	57.35	0.02	41.03	100	0	QP
0.214	62.2	51.56	101	-38.8	51.49	0.02	40.87	100	0	Average
0.321	53.43	46.02	97.47	-44.04	48.15	0.03	40.77	100	0	Average
0.428	45.73	40.28	94.98	-49.25	46.09	0.05	40.69	100	0	Average
0.535	46.15	42.15	73.04	-26.89	44.59	0.07	40.66	100	0	QP
0.642	42.01	39.18	71.45	-29.44	43.42	0.09	40.68	100	0	QP

Antenna Polarity & Test Distance: Ground-parallel at 3 m										
Frequency (MHz)	Emission Level (dBuV/m)	Read Level (dBuV)	Limit (dBuV/m)	Margin (dB)	Antenna Factor (dB/m)	Cable Loss (dB)	Preamp Factor (dB)	Antenna Height (cm)	Table Angle (Degree)	Remark
0.107	89.75	73.41	107.02	-17.27	57.35	0.02	41.03	100	360	QP
0.214	62.63	51.99	101	-38.37	51.49	0.02	40.87	100	360	Average
0.321	57.28	49.87	97.47	-40.19	48.15	0.03	40.77	100	360	Average
0.428	49.68	44.23	94.98	-45.3	46.09	0.05	40.69	100	360	Average
0.535	49.76	45.76	73.04	-23.28	44.59	0.07	40.66	100	360	QP
0.642	46.69	43.86	71.45	-24.76	43.42	0.09	40.68	100	360	QP

Remarks:

1. Emission level (dBuV/m) = Raw Value (dBuV) + Correction Factor (dB/m)
2. Correction Factor (dB/m) = Antenna Factor (dB/m) + Cable Factor (dB) – Pre-Amplifier Factor (dB)
3. The other emission levels were very low against the limit.
4. Margin value = Emission level – Limit value.
5. Above limits have been translated by the formula

EUT Test Condition		Measurement Detail	
Input Power	120 Vac, 60 Hz	Frequency Range	30 MHz ~ 1000 MHz
Environmental Conditions	25 deg. C, 65 % RH	Detector Function	Peak
Tested By	Jisyong Wang		

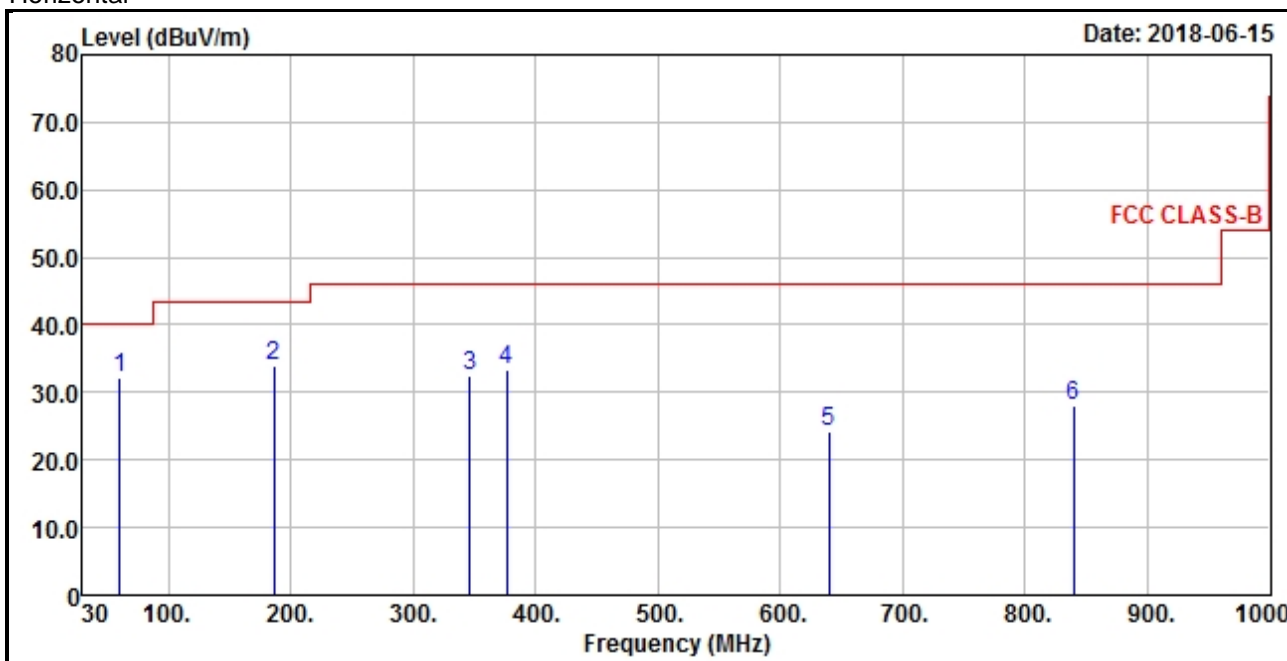
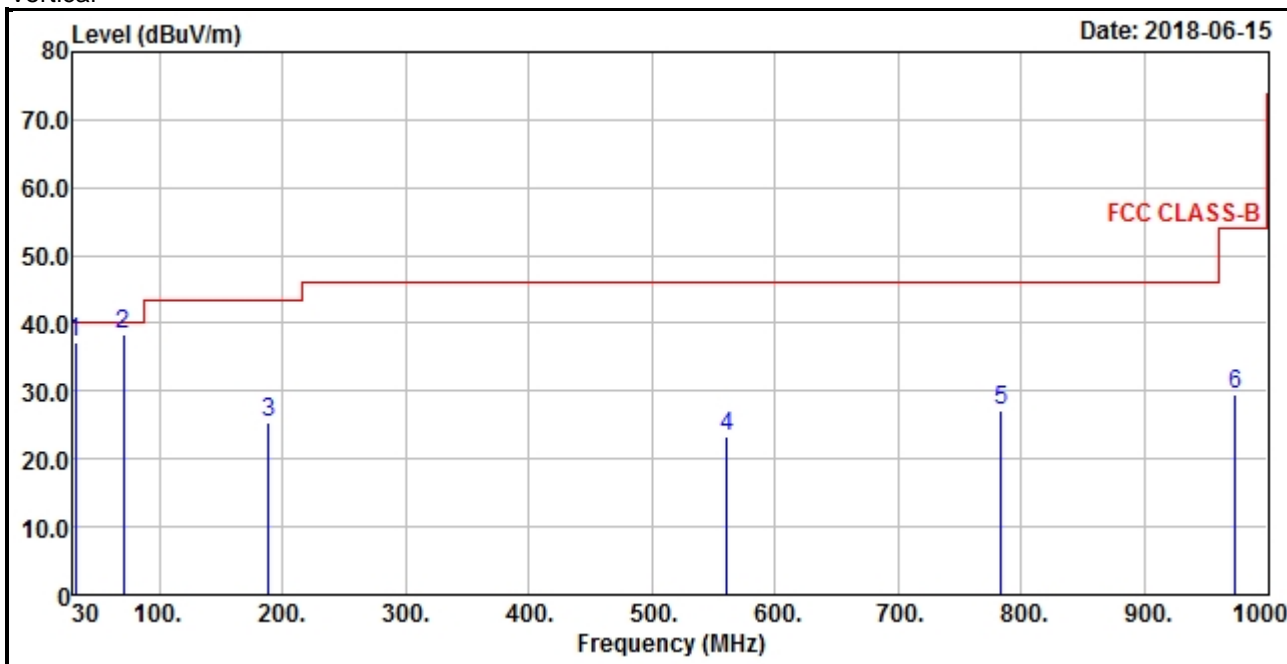
Horizontal

Vertical

Antenna Polarity & Test Distance: Horizontal at 3 m

Frequency (MHz)	Emission Level (dBuV/m)	Read Level (dBuV)	Limit (dBuV/m)	Margin (dB)	Antenna Factor (dB/m)	Cable Loss (dB)	Preamp Factor (dB)	Antenna Height (cm)	Table Angle (Degree)	Remark
60.07	32.19	51.03	40	-7.81	11.94	0.58	31.36	132	111	Peak
186.17	33.85	54.11	43.5	-9.65	10.33	1.15	31.74	174	185	Peak
346.22	32.61	48.53	46	-13.39	14.05	1.86	31.83	132	256	Peak
376.29	33.44	48.62	46	-12.56	14.77	1.99	31.94	102	185	Peak
640.13	24.11	33.04	46	-21.89	20.09	3.07	32.09	111	132	Peak
839.95	28.08	33.34	46	-17.92	22.74	3.8	31.8	165	285	Peak

Antenna Polarity & Test Distance: Vertical at 3 m

Frequency (MHz)	Emission Level (dBuV/m)	Read Level (dBuV)	Limit (dBuV/m)	Margin (dB)	Antenna Factor (dB/m)	Cable Loss (dB)	Preamp Factor (dB)	Antenna Height (cm)	Table Angle (Degree)	Remark
31.94	37.12	55.48	40	-2.88	12.3	0.45	31.11	285	145	Peak
70.74	38.52	59.14	40	-1.48	10.53	0.64	31.79	102	295	Peak
189.08	25.3	45.7	43.5	-18.2	10.12	1.17	31.69	121	152	Peak
560.59	23.19	33.81	46	-22.81	18.7	2.74	32.06	102	274	Peak
783.69	27.17	32.98	46	-18.83	22	3.61	31.42	265	295	Peak
973.81	29.44	33	54	-24.56	23.92	4.34	31.82	203	214	Peak

Remarks:

1. Emission Level = Read Level + Antenna Factor + Cable Loss - Preamp Factor
Margin value = Emission level – Limit value.

<Standby Mode>

EUT Test Condition		Measurement Detail	
Input Power	120 Vac, 60 Hz	Frequency Range	0.009 ~ 30 MHz
Environmental Conditions	25 deg. C, 65 % RH	Detector Function	Average Quasi-Peak
Tested By	Jisyong Wang		

Antenna Polarity & Test Distance: Open at 3 m

Frequency (MHz)	Emission Level (dBuV/m)	Read Level (dBuV)	Limit (dBuV/m)	Margin (dB)	Antenna Factor (dB/m)	Cable Loss (dB)	Preamp Factor (dB)	Antenna Height (cm)	Table Angle (Degree)	Remark
0.222	62.36	51.98	100.68	-38.32	51.22	0.02	40.86	100	360	Average
0.333	46.26	39.08	97.16	-50.9	47.91	0.03	40.76	100	360	Average
0.435	39.99	34.65	94.83	-54.84	45.98	0.05	40.69	100	360	Average
0.561	36.34	32.63	72.62	-36.28	44.31	0.07	40.67	100	360	QP
0.632	33.31	30.39	71.59	-38.28	43.52	0.08	40.68	100	360	QP

Antenna Polarity & Test Distance: Close at 3 m

Frequency (MHz)	Emission Level (dBuV/m)	Read Level (dBuV)	Limit (dBuV/m)	Margin (dB)	Antenna Factor (dB/m)	Cable Loss (dB)	Preamp Factor (dB)	Antenna Height (cm)	Table Angle (Degree)	Remark
0.251	57.24	47.85	99.61	-42.37	50.2	0.02	40.83	100	0	Average
0.335	51.89	44.78	97.1	-45.21	47.84	0.03	40.76	100	0	Average
0.431	45.73	40.34	94.91	-49.18	46.03	0.05	40.69	100	0	Average
0.562	46.15	42.5	72.61	-26.46	44.25	0.07	40.67	100	0	QP
0.661	41.54	38.91	71.2	-29.66	43.23	0.09	40.69	100	0	QP

Antenna Polarity & Test Distance: Ground-parallel at 3 m

Frequency (MHz)	Emission Level (dBuV/m)	Read Level (dBuV)	Limit (dBuV/m)	Margin (dB)	Antenna Factor (dB/m)	Cable Loss (dB)	Preamp Factor (dB)	Antenna Height (cm)	Table Angle (Degree)	Remark
0.235	57.86	47.95	100.18	-42.32	50.74	0.02	40.85	100	360	Average
0.336	56.34	49.23	97.08	-40.74	47.84	0.03	40.76	100	360	Average
0.448	49.1	43.96	94.58	-45.48	45.77	0.05	40.68	100	360	Average
0.552	49.76	45.93	72.77	-23.01	44.42	0.07	40.66	100	360	QP
0.662	46.41	43.78	71.19	-24.78	43.23	0.09	40.69	100	360	QP

Remarks:

1. Emission level (dBuV/m) = Raw Value (dBuV) + Correction Factor (dB/m)
2. Correction Factor (dB/m) = Antenna Factor (dB/m) + Cable Factor (dB) – Pre-Amplifier Factor (dB)
3. The other emission levels were very low against the limit.
4. Margin value = Emission level – Limit value.
5. Above limits have been translated by the formula

EUT Test Condition		Measurement Detail	
Input Power	120 Vac, 60 Hz	Frequency Range	30 MHz ~ 1000 MHz
Environmental Conditions	25 deg. C, 65 % RH	Detector Function	Peak
Tested By	Jisyong Wang		

Horizontal

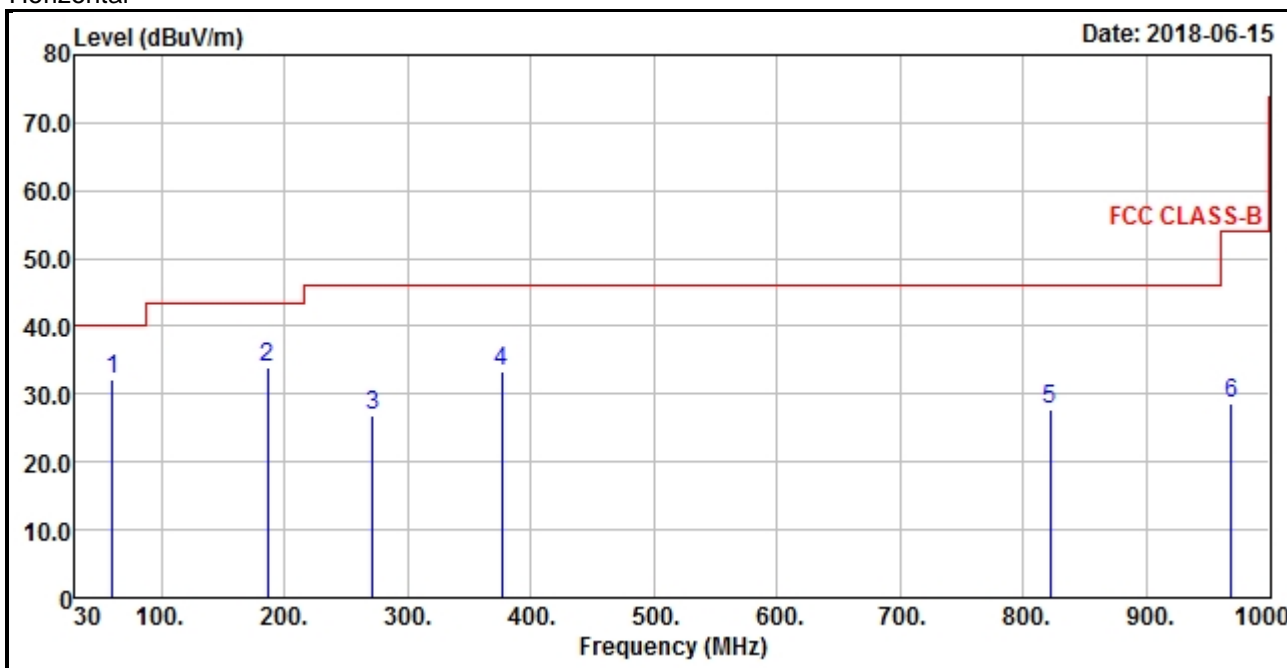

Vertical

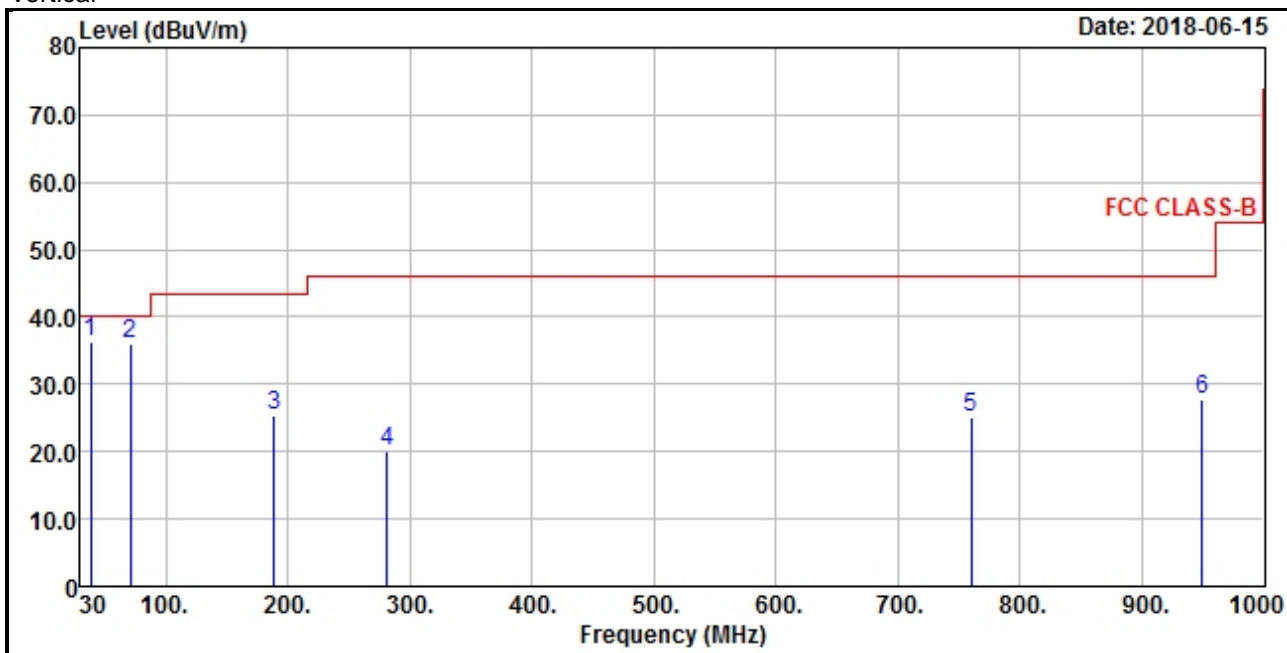

Antenna Polarity & Test Distance: Horizontal at 3 m

Frequency (MHz)	Emission Level (dBuV/m)	Read Level (dBuV)	Limit (dBuV/m)	Margin (dB)	Antenna Factor (dB/m)	Cable Loss (dB)	Preamp Factor (dB)	Antenna Height (cm)	Table Angle (Degree)	Remark
60.07	32.19	51.03	40	-7.81	11.94	0.58	31.36	111	152	Peak
186.17	33.85	54.11	43.5	-9.65	10.33	1.15	31.74	132	256	Peak
271.53	26.85	45.2	46	-19.15	12.11	1.53	31.99	185	147	Peak
376.29	33.44	48.62	46	-12.56	14.77	1.99	31.94	102	256	Peak
821.52	27.76	33.13	46	-18.24	22.5	3.75	31.62	165	285	Peak
968.96	28.77	32.43	54	-25.23	23.9	4.32	31.88	185	123	Peak

Antenna Polarity & Test Distance: Vertical at 3 m

Frequency (MHz)	Emission Level (dBuV/m)	Read Level (dBuV)	Limit (dBuV/m)	Margin (dB)	Antenna Factor (dB/m)	Cable Loss (dB)	Preamp Factor (dB)	Antenna Height (cm)	Table Angle (Degree)	Remark
38.73	36.4	53.53	40	-3.6	13.39	0.48	31	185	214	Peak
70.74	36.14	56.76	40	-3.86	10.53	0.64	31.79	111	165	Peak
189.08	25.3	45.7	43.5	-18.2	10.12	1.17	31.69	202	236	Peak
281.23	20.12	37.95	46	-25.88	12.4	1.58	31.81	147	185	Peak
760.41	25.12	31.36	46	-20.88	21.67	3.54	31.45	165	298	Peak
949.56	27.68	31.49	46	-18.32	23.79	4.22	31.82	111	321	Peak

Remarks:

1. Emission Level = Read Level + Antenna Factor + Cable Loss - Preamp Factor

Margin value = Emission level – Limit value.

4.2 Conducted Emission Measurement

4.2.1 Limits of Conducted Emission Measurement

Frequency (MHz)	Conducted Limit (dBuV)	
	Quasi-Peak	Average
0.15 - 0.5	66 - 56	56 - 46
0.50 - 5.0	56	46
5.0 - 30.0	60	50

Note:

1. The lower limit shall apply at the transition frequencies.
2. The limit decreases in line with the logarithm of the frequency in the range of 0.15 to 0.50 MHz.
3. All emanations from a class A/B digital device or system, including any network of conductors and apparatus connected thereto, shall not exceed the level of field strengths specified above.

4.2.2 Test Instruments

Description & Manufacturer	Model No.	Serial No.	Date of Calibration	Due Date of Calibration
Test Receiver ROHDE & SCHWARZ	ESCI	100613	Nov. 23, 2017	Nov. 22, 2018
RF signal cable (with 10dB PAD) Woken	5D-FB	Cable-cond1-01	Sep. 05, 2017	Sep. 04, 2018
LISN/AMN ROHDE & SCHWARZ (EUT)	ESH3-Z5	835239/001	Mar. 06, 2018	Mar. 05, 2019
LISN/AMN ROHDE & SCHWARZ (Peripheral)	ESH3-Z5	100311	Aug. 15, 2017	Aug. 14, 2018
Software ADT	BV ADT_Cond_ V7.3.7.4	NA	NA	NA

- Note:
1. The calibration interval of the above test instruments is 12 months and the calibrations are traceable to NML/ROC and NIST/USA.
 2. The test was performed in HwaYa Shielded Room 1.
 3. The VCCI Site Registration No. is C-2040.

4.2.3 Test Procedures

- a. The EUT was placed 0.4 meters from the conducting wall of the shielded room with EUT being connected to the power mains through a line impedance stabilization network (LISN). Other support units were connected to the power mains through another LISN. The two LISNs provide 50 ohm/ 50 uH of coupling impedance for the measuring instrument.
- b. Both lines of the power mains connected to the EUT were checked for maximum conducted interference.
- c. The frequency range from 150 kHz to 30 MHz was searched. Emission levels under (Limit – 20 dB) was not recorded.

NOTE: The resolution bandwidth and video bandwidth of test receiver is 9 kHz for quasi-peak detection (QP) and average detection (AV) at frequency 0.15 MHz - 30 MHz.

4.2.4 Deviation from Test Standard

No deviation.

4.2.5 Test Setup

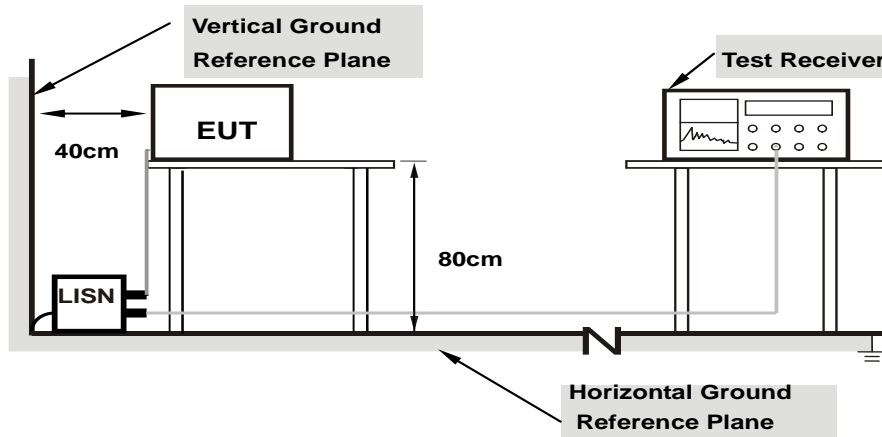

Note: 1.Support units were connected to second LISN.

For the actual test configuration, please refer to the attached file (Test Setup Photo).

4.2.6 EUT Operating Conditions

Same as 4.1.6.

4.2.7 Test Results

Frequency Range	150kHz ~ 30MHz	Detector Function & Resolution Bandwidth	Quasi-Peak (QP) / Average (AV), 9kHz
Input Power	120Vac, 60Hz	Environmental Conditions	25°C, 65%RH
Tested by	Jisyong Wang	Test Date	2018/6/14

Phase Of Power : Line (L)										
No	Frequency (MHz)	Correction Factor (dB)	Reading Value (dBuV)		Emission Level (dBuV)		Limit (dBuV)		Margin (dB)	
			Q.P.	AV.	Q.P.	AV.	Q.P.	AV.	Q.P.	AV.
1	0.20084	10.10	36.70	21.19	46.80	31.29	63.58	53.58	-16.78	-22.29
2	0.24472	10.11	33.19	19.13	43.30	29.24	61.93	51.93	-18.63	-22.69
3	0.54089	10.12	24.72	10.86	34.84	20.98	56.00	46.00	-21.16	-25.02
4	1.62016	10.17	23.00	9.13	33.17	19.30	56.00	46.00	-22.83	-26.70
5	8.22806	10.52	23.45	10.34	33.97	20.86	60.00	50.00	-26.03	-29.14
6	14.60918	10.89	31.76	17.78	42.65	28.67	60.00	50.00	-17.35	-21.33

Remarks:

1. Q.P. and AV. are abbreviations of quasi-peak and average individually.
2. The emission levels of other frequencies were very low against the limit.
3. Margin value = Emission level – Limit value
4. Correction factor = Insertion loss + Cable loss
5. Emission Level = Correction Factor + Reading Value

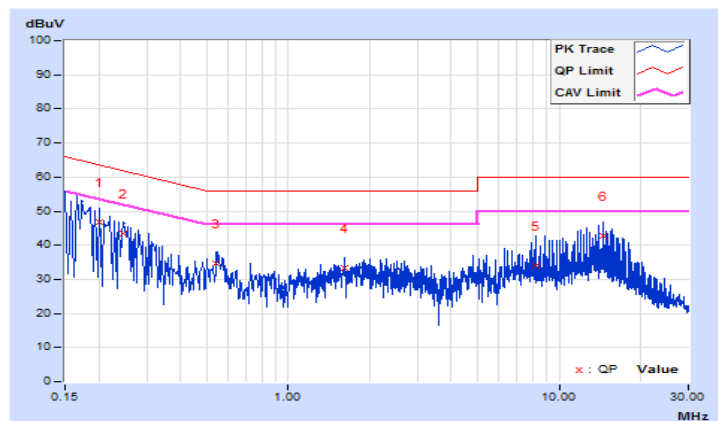

Frequency Range	150kHz ~ 30MHz	Detector Function & Resolution Bandwidth	Quasi-Peak (QP) / Average (AV), 9kHz
Input Power	120Vac, 60Hz	Environmental Conditions	25°C, 65%RH
Tested by	Jisyong Wang	Test Date	2018/6/14

Phase Of Power : Neutral (N)										
No	Frequency (MHz)	Correction Factor (dB)	Reading Value (dBuV)		Emission Level (dBuV)		Limit (dBuV)		Margin (dB)	
			Q.P.	AV.	Q.P.	AV.	Q.P.	AV.	Q.P.	AV.
1	0.16955	10.10	39.19	25.49	49.29	35.59	64.98	54.98	-15.69	-19.39
2	0.19510	10.10	36.64	22.85	46.74	32.95	63.82	53.82	-17.08	-20.87
3	0.56055	10.12	22.66	8.19	32.78	18.31	56.00	46.00	-23.22	-27.69
4	4.69342	10.30	13.82	1.03	24.12	11.33	56.00	46.00	-31.88	-34.67
5	12.06768	10.61	29.57	15.66	40.18	26.27	60.00	50.00	-19.82	-23.73
6	16.37259	10.79	34.81	21.12	45.60	31.91	60.00	50.00	-14.40	-18.09

Remarks:

1. Q.P. and AV. are abbreviations of quasi-peak and average individually.
2. The emission levels of other frequencies were very low against the limit.
3. Margin value = Emission level – Limit value
4. Correction factor = Insertion loss + Cable loss
5. Emission Level = Correction Factor + Reading Value

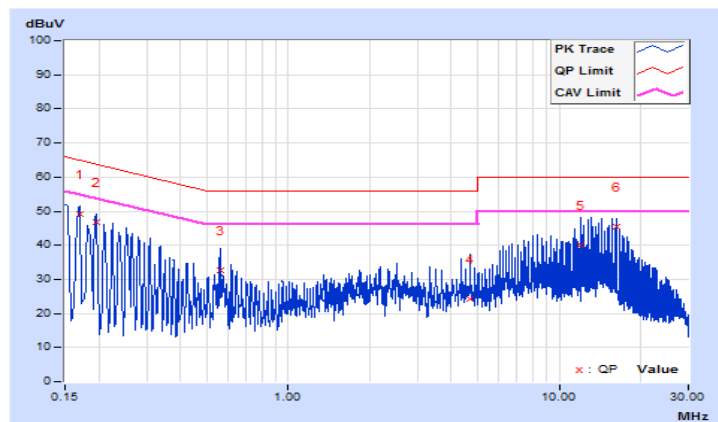



5 Pictures of Test Arrangements

Please refer to the attached file (Test Setup Photo).



Appendix – Information on the Testing Laboratories

We, Bureau Veritas Consumer Products Services (H.K.) Ltd., Taoyuan Branch, were founded in 1988 to provide our best service in EMC, Radio, Telecom and Safety consultation. Our laboratories are FCC recognized accredited test firms and accredited according to ISO/IEC 17025.

If you have any comments, please feel free to contact us at the following:

Linko EMC/RF Lab

Tel: 886-2-26052180

Fax: 886-2-26051924

Hsin Chu EMC/RF/Telecom Lab

Tel: 886-3-6668565

Fax: 886-3-6668323

Hwa Ya EMC/RF/Safety Lab

Tel: 886-3-3183232

Fax: 886-3-3270892

Email: service.adt@tw.bureauveritas.com

Web Site: www.bureauveritas-adt.com

The address and road map of all our labs can be found in our web site also.

--- END ---